

54-28275-02m0
030-30793



Package Insert

TheraSphere® Yttrium-90 Glass Microspheres

Humanitarian Device.

Authorized by Federal Law for use in radiation treatment or as a neoadjuvant to surgery or transplantation in patients with unresectable hepatocellular carcinoma (HCC) who can have placement of appropriately positioned hepatic arterial catheters. The device is also indicated for HCC patients with partial or branch portal vein thrombosis/occlusion, when clinical evaluation warrants the treatment. The effectiveness of this device for this use has not been demonstrated.

CAUTION: Federal (USA) law restricts this device to sale by or on the order of a physician with appropriate training and experience.

DESCRIPTION

TheraSphere® consists of insoluble glass microspheres where yttrium-90 is an integral constituent of the glass [1]. The mean sphere diameter ranges from 20 to 30 µm. Each milligram contains between 22,000 and 73,000 microspheres. TheraSphere® is supplied in 0.6 mL of sterile, pyrogen-free water contained in a 1.0 mL vee-bottom vial secured within a clear acrylic vial shield. TheraSphere® is available in six dose sizes: 3 GBq (81 mCi), 5 GBq (135 mCi), 7 GBq (189 mCi), 10 GBq (270 mCi), 15 GBq (405 mCi) and 20 GBq (540 mCi).

A preassembled single use TheraSphere® Administration Set is provided for each dose. The TheraSphere® Administration Accessory Kit is supplied to new user sites. The kit includes re-usable accessories including an acrylic box base, top shield, removable side shield, bag hook and a RADOS RAD-60R radiation dosimeter (or equivalent).

Yttrium-90, a pure beta emitter, decays to stable zirconium-90 with a physical half-life of 64.1 hours (2.67 days). The average energy of the beta emissions from yttrium-90 is 0.9367 MeV.

Following embolization of the yttrium-90 glass microspheres in tumorous liver tissue, the beta radiation emitted provides a therapeutic effect [2-6]. The microspheres are delivered into the liver tumor through a catheter placed into the hepatic artery that supplies blood to the tumor. The microspheres, being unable to pass through the vasculature of the liver due to arteriolar capillary blockade, are trapped in the tumor and exert a local radiotherapeutic effect with some concurrent damage to surrounding normal liver tissue [7-14].

INDICATION

TheraSphere® is indicated for radiation treatment or as a neoadjuvant to surgery or transplantation in patients with unresectable HCC who can have placement of appropriately positioned hepatic arterial catheters. The device is also indicated for HCC patients with partial or branch portal vein thrombosis/occlusion, when clinical evaluation warrants the treatment.

REC'D IN LAT 09/24/2014

584987
NMSS/RGNI MATERIALS-002



CONTRAINDICATIONS

The use of TheraSphere® is contraindicated in patients:

- whose Tc-99m macroaggregated albumin (MAA) hepatic arterial perfusion scintigraphy shows any deposition to the gastrointestinal tract that may not be corrected by angiographic techniques (see Item 1 under **INDIVIDUALIZATION OF TREATMENT**);
- who show shunting of blood to the lungs that could result in delivery of greater than 16.5 mCi of yttrium-90 to the lungs. Radiation pneumonitis has been seen in patients receiving doses to the lungs greater than 30 Gy in a single treatment (see Item 2 under **INDIVIDUALIZATION OF TREATMENT**);
- in whom hepatic artery catheterization is contraindicated; such as patients with vascular abnormalities or bleeding diathesis;
- who have severe liver dysfunction or pulmonary insufficiency; and
- who present with complete occlusion of the main portal vein (see Item 3 under **INDIVIDUALIZATION OF TREATMENT**).

PRECAUTIONS/WARNINGS

A retrospective study of 121 patients from 5 clinical trials has shown that the following 5 Pre-treatment High Risk Factors have been associated with at least 48% of all serious adverse events that were possibly related to use of the device and with 11 of the 12 deaths that were possibly related to use of the device:

- infiltrative tumor type
- "Bulk disease" (tumor volume > 70% of the target liver volume, or tumor nodules too numerous to count)
- AST or ALT > 5 times ULN
- bilirubin > 2 mg/dL
- tumor volume > 50% combined with an albumin < 3 g/dL

The physician should always take the above-noted Pre-treatment High Risk Factors into consideration for each patient when making decisions regarding the use of TheraSphere® for treatment.

- Radioactive products should be used only by physicians who are qualified by specific training in the safe use and handling of radionuclides and whose experience and training have been approved by the appropriate government agency authorized to license the use of radionuclides.
- Adequate shielding and precautions for handling radioactive material must be maintained.
- As in the use of any radioactive material, care should be taken to ensure minimum radiation exposure to the patient extraneous to the therapeutic objective and to ensure minimum radiation exposure to workers and others in contact with the patient.
- Since adequate studies have not been performed in animals to determine whether this device affects fertility in males or females, has teratogenic potential, or has other adverse effects on the fetus, this product should not be administered to pregnant or nursing women unless it is considered that the benefits to be gained outweigh the potential hazards.
- Ideally the use of this radioactive device in women of childbearing capability should be performed during the first few (approximately 10) days following the onset of menses.
- Dose rate to personnel should be monitored during administration. Any spills or leaks must be cleaned up immediately and the area monitored for contamination at the end of the procedure.
- The TheraSphere® dose vial is supplied secured within a clear acrylic vial shield to limit radiation exposure to personnel. The dose rate at the vial shield surface is still high enough to require caution including the use of tongs and a lead shielded container when possible. The TheraSphere® dose vial should always be stored in a shielded location away from personnel.



ADVERSE REACTIONS

Based on clinical and preclinical animal experience with TheraSphere® and other yttrium-90 microspheres, certain adverse reactions have been identified [4-6, 15, 16, 17, 18]. Serious adverse events that occurred under clinical studies and that were definitely, probably or possibly related to TheraSphere®, or if the relationship was unknown, are summarized in Table 1. In addition to these serious adverse events, lymphocyte depression, which may be graded as moderate to severe but with no clinical sequelae, is expected to occur in some patients.

The introduction of microspheres into the vasculature of the stomach, duodenum or other organs of the gastrointestinal tract may cause chronic pain, ulceration and bleeding. Microsphere shunting to the lungs may cause edema and fibrosis that may not be reversible.

Extrahepatic shunting may be identified through the injection of Tc-99m MAA into the hepatic artery [19, 20]. Flow of radioactivity to the gastrointestinal tract may be avoided by the use of balloon catheterization or other angiographic techniques to block such flow [21]. In addition, placement of the delivery catheter in the hepatic branch distal to collateral vessels provides a safety margin with respect to inadvertent deposition of microspheres.

Some adverse events observed may be explained by the effect of attenuated radiation from the treated liver. Pleural effusion may be caused by attenuated radiation when the treated tumor is positioned proximal to the base of the lung. Similarly, treatment of tumors in the left lobe of the liver, in proximity to the gut, may explain some of the gastrointestinal events observed. Putative attenuated radiation effects to extrahepatic structures have generally been found to resolve over time.

The use of this product leads to irradiation of both tumorous and normal liver tissue. As a result, patients with diseases that compromise the functioning of their normal liver tissue or patients with either diffuse tumors or a high tumor burden may be at greater risk of liver function impairment.

A number of patient baseline characteristics, indicative of either impaired normal liver function or tumor status, correlated with a higher incidence of liver-related serious adverse events in clinical trials.

A retrospective study of 121 patients from 5 clinical trials has shown that the following 5 Pre-treatment High Risk Factors have been associated with at least 48% of all serious adverse events that were possibly related to use of the device and with 11 of the 12 deaths that were possibly related to use of the device:

- infiltrative tumor type
- "Bulk disease" (tumor volume > 70% of the target liver volume, or tumor nodules too numerous to count)
- AST or ALT > 5 times ULN
- bilirubin > 2 mg/dL
- tumor volume > 50% combined with an albumin < 3 g/dL

The physician should always take the above-noted Pre-treatment High Risk Factors into consideration for each patient when making decisions regarding the use of TheraSphere® for treatment.



Table 1

Treatment-Emergent Serious Adverse Events from 5 Clinical Studies (N=121) for Patients Undergoing TheraSphere® Treatment Therapy

Adverse Event	Severe		Life Threatening		Fatal		Total	
	N	(%)	N	(%)	N	(%)	N	(%)
Elevated bilirubin	16	(57.1)	10	(35.7)	2	(7.1)	28	(23.1)
Ascites	10	(100)	0		0		10	(8.3)
Abdominal pain	8	(100)	0		0		8	(6.6)
Elevated SGOT/SGPT	7	(100)	0		0		7	(5.8)
Gastric ulcer	4	(80)	0		1	(20)	5	(4.1)
Elevated Alkaline Phosphatase	4	(100)	0		0		4	(3.3)
Pain, not abdominal	4	(100)	0		0		4	(3.3)
Hepatic encephalopathy	2	(66.7)	1	(33.3)	0		3	(2.5)
Elevated LDH	3	(100)	0		0		3	(2.5)
Elevated prothrombin time	2	(66.7)	1	(33.3)	0		3	(2.5)
Liver failure	0		0		2	(100)	2	(1.7)
Cholecystitis	0		2	(100)	0		2	(1.7)
Nausea	2	(100)	0		0		2	(1.7)
Edema	0		2	(100)	0		2	(1.7)
Fatigue	2	(100)	0		0		2	(1.7)
Malaise	2	(100)	0		0		2	(1.7)
Death, not otherwise specified	0		0		2	(100)	2	(1.7)
Hepatic decompensation	1	(100)	0		0		1	(0.8)
Hepatitis	0		0		1	(100)	1	(0.8)
Radiation hepatitis	1	(100)	0		0		1	(0.8)
Duodenal ulcer	1	(100)	0		0		1	(0.8)
Hypertension	1	(100)	0		0		1	(0.8)
Hypotension	1	(100)	0		0		1	(0.8)
Pleural effusion	1	(100)	0		0		1	(0.8)
Aspiration pneumonia	0		1	(100)	0		1	(0.8)
Pneumonitis	0		0		1	(100)	1	(0.8)
Radiation pneumonitis	0		0		1	(100)	1	(0.8)
Fall	1	(100)	0		0		1	(0.8)
Gastrointestinal bleed	1	(100)	0		0		1	(0.8)
Hemorrhage, not otherwise specified	1	(100)	0		0		1	(0.8)
Decreased platelets	1	(100)	0		0		1	(0.8)
Allergic reaction	1	(100)	0		0		1	(0.8)
Bacterial sepsis	0		0		1	(100)	1	(0.8)
Hypoglycemia	1	(100)	0		0		1	(0.8)
Hepatorenal failure	0		0		1	(100)	1	(0.8)

CLINICAL STUDIES

1. 100 Gy HCC Study [22]

- **Objectives:** To define the activity of yttrium-90 microspheres given by hepatic artery infusion to a previously untreated patient with primary HCC; to evaluate the survival of patients treated with yttrium-90 microspheres; and to evaluate the toxicity of yttrium-90 microsphere therapy.
- **Study Design:** Patients with HCC were treated with a target dose of TheraSphere® of 100 Gy by injection through the hepatic artery. Patients underwent laboratory tests, history and physical examinations, and liver ultrasounds or computerized tomography (CT) scans for up to 2 years after treatment. Response duration was calculated from the date of treatment with TheraSphere® to the date of documentation of progression of disease. Survival was calculated from the date of treatment with TheraSphere® until the date of death. Toxicities were coded using the Southwest Oncology Group (SWOG; Operations Office, San Antonio, TX) grading system (last revised 12/94), i.e. grade 1 = mild, grade 2 = moderate, grade 3 = severe, grade 4 = life threatening, and grade 5 = lethal/fatal. If a patient's transaminase was above normal at baseline and the patient experienced a further increase during the study, SWOG grading was not applied; rather, a grade 1 toxicity (mild) was defined as a 1-50% increase from baseline, a grade 2 toxicity (moderate) as a 51-200% increase from baseline, and a grade 3 toxicity (severe) as a >200% increase from baseline.
- **Patient Inclusion Criteria:** Presence of histologically confirmed unresectable HCC confined to the liver and at least one measurable lesion; Eastern Cooperative Oncology Group (ECOG) performance status 0-3; estimated life expectancy greater than 12 weeks; absolute granulocyte count $2.0 \times 10^9/L$ or greater; platelet count $100 \times 10^9/L$ or greater; prothrombin time (PT) and activated partial thromboplastin time within normal limits; bilirubin less than 1.5 x upper normal limit; serum glutamic oxaloacetic transaminase (SGOT), serum glutamic pyruvic transaminase (SGPT), and alkaline phosphatase less than 5 x upper normal limit; normal pulmonary function defined as no more than 30% greater or less than the expected normal.
- **Study Population and Treatment Administration:** Twenty-two patients were treated. Two patients were excluded from the evaluation of probable benefit due to an unconfirmed diagnosis of HCC. Twenty patients received one TheraSphere® treatment; two patients received a second TheraSphere® treatment based on the principle investigator's discretion. Nine patients were classified as Okuda stage I and 11 patients as Okuda stage II. The median activity administered was 3.9 GBq (range, 2.0 GBq to 9.2 GBq). The median liver dose was 104 Gy (range, 46 Gy to 145 Gy).
- **Safety Results:** One patient suffered from a possible angiography contrast agent allergic reaction that was judged by investigator to be severe in nature. All 22 treated patients reported at least one treatment-emergent adverse event; however, the majority (85%) of the adverse events were graded as mild or moderate in severity. The most common serious (i.e. graded as severe, life threatening, or lethal/fatal) adverse events were liver related (45%) and gastrointestinal (19%). Liver toxicities were primarily elevated enzymes during the week after treatment. The gastrointestinal toxicities included three ulcers, one ileus, and one nausea. Three patients died during the follow-up period. The deaths were attributed to hepatitis (death approximately 5 months after TheraSphere® treatment; judged as possibly related to TheraSphere®), gastric ulcer (death approximately 2 months after TheraSphere® treatment; judged as probably related to TheraSphere®), and radiation pneumonitis (death approximately 2 months after TheraSphere® treatment; judged as definitely related to TheraSphere® after the patient received an estimated dose of 56 Gy to the lungs as a result of pulmonary shunting).
- **Probable Benefit:** As of February 14, 1997, two patients remained alive resulting in a median survival of 378 days (95% CI, 209-719), with a minimum survival of 49 days and a maximum survival of 1,265 days. Based on a stratified Cox survival analysis model, activity ratio, Okuda stage, and liver dose appeared to influence survival by approximately the same magnitude of effect.



2. Pilot HCC [4] and Mixed Neoplasia Studies [3, 11]

- **Objectives:** The objectives of the Pilot HCC study were to define the activity of yttrium-90 microspheres administered by hepatic arterial infusion to patients with HCC and to evaluate the toxicity of yttrium-90 microsphere therapy.
- The objectives of the Mixed Neoplasia study were to evaluate the toxicity of yttrium-90 microsphere therapy and to define, using escalating radiation doses, the maximum tolerated dose of yttrium-90 glass microspheres administered by hepatic arterial infusion that would be suitable for Phase II-III studies in a similar patient population.
- **Study Design:** Patients in the Pilot HCC study received TheraSphere® in an amount that was determined to deliver a radiation absorbed dose of approximately 50 Gy to the tumor. The Mixed Neoplasia study was designed to treat patients with metastatic colonic carcinoma of the liver, carcinoid tumor metastatic to the liver, or primary hepatobiliary carcinoma. Patients received a single injection of TheraSphere® with an initial group of patients receiving a calculated radiation absorbed dose of 50 Gy to the liver; after determination of acceptable and reversible toxicity, a second group of patients received 75 Gy to the liver followed by a third group of patients who received 100 Gy to the liver.
- For both studies, response duration was calculated from the date of treatment with TheraSphere® to the date of documentation of progression of disease. Survival was calculated from the date of treatment with TheraSphere® until the date of death. Toxicities were coded using the SWOG grading system (see above under 100 Gy HCC Study).
- **Study Population and Treatment Administration:** Thirteen patients, nine from the Pilot HCC study and four from the Mixed Neoplasia study, provide safety data. All 13 patients were treated once with TheraSphere®. The median activity administered was 2.6 GBq (range, 2.2 GBq to 6.6 GBq). The median liver dose was 74 Gy (range, 34 Gy to 105 Gy). Because of the dose escalation, seven patients received less than 80 Gy.
- **Safety Results:** All 13 treated patients reported at least one treatment-emergent adverse event; however, the majority (82%) of the adverse events were graded as mild or moderate in severity. The most common serious (i.e., graded as severe, life threatening, or lethal/fatal) adverse events were liver related (43%). Liver toxicities were primarily due to elevated enzymes during the week after treatment. Among the serious adverse events, two patients also experienced gastric ulcers. Two patients died during the follow-up period. The deaths were attributed to elevated bilirubin (elevated before TheraSphere® treatment that increased in severity 2 days after treatment and continued until the patient's death 2 weeks later; judged as possibly related to TheraSphere®), and pneumonitis, (death approximately 6 weeks after TheraSphere® treatment; judged as possibly related to TheraSphere®).
- **Probable Benefit:** Table 2 shows the median survival (months) following treatment with TheraSphere® at doses <80 Gy and ≥80 Gy in patients with adenocarcinoma and HCC.



Table 2
TheraSphere® Median Survival (Months)

	Dose <80 Gy	Dose ≥80 Gy
Adenocarcinoma	9.1 (n=22)	9.7 (n=50)
Hepatocellular carcinoma	3.6 (n=8)	11.1 (n=7)

INDIVIDUALIZATION OF TREATMENT

1. Gastroduodenal ulceration is a potential complication of misplaced deposition of radioactive microspheres. It is likely that inadvertent deposition of yttrium-90 microspheres in the terminal gastric vascular bed reflects the backflow of microspheres during administration or shunting through aberrant small vessels within the cirrhotic liver or tumor. Although angiographic occlusion techniques and the use of vasoactive drugs may reduce gastrointestinal shunting, their effectiveness is uncertain. If such flow is present and cannot be corrected using established angiographic techniques, the patient is disqualified from treatment. When the possibility of extrahepatic shunting has been evaluated and the patient deemed acceptable for treatment, TheraSphere® may be administered.
2. In some patients, part of the hepatic arterial blood supply bypasses the capillary bed and flows directly to the venous system. This may be associated with pathologic abnormalities of the liver. For such patients, a fraction F of microspheres injected into the hepatic artery will not be embolized in the liver but will flow to the heart and subsequently be deposited into the lungs. As the product of the bypass fraction, F, and the injected activity, A, increases the potential for delivering a damaging dose of radiation to the lungs increases. Consequently, it is essential that F be measured before use of this product. This procedure is performed by injecting a tracer dose of Tc-99m MAA and observing with an Anger camera. The observed radiation from the lung field, divided by the total radiation observed by the camera is a measure of F. The product of F and A is then a measure of the activity that will be deposited into the lungs [23]. Based on clinical study experience [15, 16] with radioactive microspheres and TheraSphere® in HCC treatment, an upper limit of $F \times A$ of 610 MBq (16.5 mCi) is recommended. The estimated dose (Gy) to the lungs is equal to A (GBq) $\times F \times 50$, and assuming the total mass of both lungs to be 1 kg [24]; an upper limit of dose to the lungs from a single TheraSphere® treatment is 30 Gy.
3. Portal vein thrombosis (PVT) is observed in over 40% of HCC patients who are potential candidates for TheraSphere® treatment [34]. For patients presenting with PVT, the clinician should weigh the risk versus benefit of yttrium-90 microsphere treatment. In a retrospective analysis of 25 patients presenting with branch or partial portal vein thrombosis, there was no increase in hepatic failure, hepatic encephalopathy, worsening of pre-existing portal hypertension, or extension of pre-existing portal vein occlusion following treatment with TheraSphere® [35]. The most common adverse event observed after TheraSphere® treatment in HCC patients presenting with PVT was elevated bilirubin. In all cases, elevated bilirubin was not treatment related but was attributed to progression of liver disease or cirrhosis [36]. Patients who present with PVT and symptoms of severe portal hypertension are at risk of liver decompensation and the risk versus benefit should be weighed accordingly. Patients presenting with complete occlusion of the main portal vein should not be considered for treatment due to the higher risk of liver failure, and potential complications (e.g. intestinal infarct, necrosis, varical bleeding, ascites) associated with this condition.



INSTRUCTIONS FOR USE

Dosage and Administration

To correct for the physical decay of yttrium-90, the fractions that remain at selected time intervals from calibration are shown in Table 3.

Table 3
Yttrium-90 Physical Decay Table
Half-Life 64.1 Hours

Hours	Fraction Remaining	Hours	Fraction Remaining	Hours	Fraction Remaining
-4	1.044	26	0.755	56	0.546
-2	1.022	28	0.739	58	0.534
0*	1.000	30	0.723	60	0.523
2	0.979	32	0.707	62	0.511
4	0.958	34	0.692	64	0.501
6	0.937	36	0.678	66	0.490
8	0.917	38	0.663	68	0.479
10	0.898	40	0.649	70	0.469
12	0.878	42	0.635	72 (Day 3)	0.459
14	0.860	44	0.621	96 (Day 4)	0.354
16	0.841	46	0.608	120 (Day 5)	0.273
18	0.823	48 (Day 2)	0.595	144 (Day 6)	0.211
20	0.806	50	0.582	168 (Day 7)	0.163
22	0.788	52	0.570		
24 (Day 1)	0.771	54	0.558		

*Calibration Time

Preliminary Patient Evaluation

Prior to the administration of TheraSphere®, the patient should undergo hepatic arterial catheterization using balloon catheterization or other appropriate angiographic techniques to prevent extrahepatic shunting [21]. Following the placement of the hepatic catheter, 75 MBq to 150 MBq (2 mCi to 4 mCi) of Tc-99m MAA is administered into the hepatic artery to determine the extent of A-V shunting to the lungs and to confirm the absence of gastric and duodenal flow. When the possibility of extrahepatic shunting has been evaluated and the patient deemed acceptable for treatment, TheraSphere® may be administered.

Calculation of Dose

The recommended dose to the liver is between 80 Gy to 150 Gy (8,000 rad to 15,000 rad). The amount of radioactivity required to deliver the desired dose to the liver may be calculated using the following formula:

$$\text{Activity Required (GBq)} = \frac{[\text{Desired Dose (Gy)}] [\text{Liver Mass (kg)}]}{50}$$

The liver volume and corresponding liver mass may be determined using CT or ultrasound scans.



For the purpose of ordering TheraSphere®, use the Yttrium-90 Physical Decay Table (Table 3) to determine the appropriate time of injection. For determining the actual liver dose (Gy) delivered to the liver after injection, the following formula is used:

$$Dose (Gy) = \frac{50 [Injected Activity (GBq)] [1-F]}{Liver Mass (kg)},$$

where F is the fraction of injected radioactivity localizing in the lungs, as measured by Tc-99m MAA scintigraphy.

The upper limit of injected activity shunted to the lungs is $F \times A = 0.61$ GBq.

Patient Catheterization

The following general guidelines are provided to facilitate the selection of the appropriate catheter for the administration of TheraSphere®:

- A catheter with an internal diameter of ≥ 0.5 mm (0.020 inch) is required to deliver TheraSphere® to the liver. Excessive resistance to flow in the administration system due to a smaller catheter diameter may cause microspheres to be retained in the TheraSphere® Administration Set and in the catheter. This could result in a misadministration.
- Since the delivery of TheraSphere® is dependent on blood flow through the hepatic vasculature distal to the catheter tip, it is important that the catheter does not occlude the vessel in which it is placed to effect delivery of TheraSphere®.

TheraSphere® Administration Set and TheraSphere® Administration Accessory Kit

The TheraSphere® Administration Set (Diagram 1 & 2) consists of a sterile disposable tubing set and one empty sterile vial. The tubing set is made of pre-assembled, sterile components and is for single use only. The pre-assembled tubing set contains a needle plunger assembly and an integrated 20 cc syringe.

The one way valves incorporated in the Administration Set control the flow of liquid such that it will only flow in the appropriate direction. Pulling back on the syringe plunger will fill the syringe from the fluid source. Pushing the syringe plunger will move fluid toward the needle plunger assembly. Prior to the infusion, the Administration Set is manually pre-primed by pushing the sterile flushing solution through the set to purge air from the lines.

The TheraSphere® Administration Accessory Kit (Diagram 2) contains re-usable accessories including an acrylic box base, top shield, removable side shield, bag hook and a RADOS RAD-60R (or equivalent) radiation dosimeter. The TheraSphere® Administration Accessory Kit ensures optimal layout of the TheraSphere® Administration Set and TheraSphere® dose vial to facilitate monitoring of the infusion process and provides beta radiation shielding.

The Accessory Kit should be placed on a sturdy cart or table that is positioned beside the patient, close to the infusion catheter inlet luer fitting. The extension arm on the Accessory Kit facilitates alignment and positioning of the Administration Set / patient catheter connection.

Throughout the administration procedure, the TheraSphere® dose vial remains sealed within the clear acrylic vial shield in which it is supplied. The removable plug at the top of the acrylic vial shield provides access to the septum of the TheraSphere® dose vial. The needle plunger assembly (Diagram 3) is designed to snap into the top of the acrylic shield, and is not easily removed once snapped into place. This provides stability and alignment for the needles which are inserted through the septum when the tabs are pushed down on the plunger assembly.



A constant syringe pressure should be maintained for the duration of each flush, with a flow rate of equal to or greater than 20 cc per minute. One flush is 20 cc as indicated on the barrel of the syringe. Using a flow rate of less than 20 cc per minute (i.e. appropriate to the flow of the native vessel) may decrease the delivery efficiency of the administration system. Flushing should be continued until optimal delivery of TheraSphere® is achieved. A minimum of three flushes for a total of 60 cc is recommended. Infusion pressure should not exceed 30 psi on any flush. The pressure relief valve in the Administration Set has been included to prevent over pressurization.

The RADOS RAD-60R (or equivalent) electronic dosimeter is mounted in a holder on the Accessory Kit. Radiation monitoring of the Administration Set must be used to determine when optimal delivery has been achieved. The ratio of the dose rate reading taken on the electronic dosimeter before and after the infusion can provide a basis for estimation of the dose delivered to the patient.

In order to minimize the potential of a high radiation hand dose, use a hemostat, forceps or towels/gauze when handling parts of the Administration Set after infusion.

Percentage of dose delivered to the patient can be calculated based on ion-chamber radiation detector measurements of the dose prior to administration, compared to measurements of the waste after administration. Before administration the acrylic shield containing the dose is measured at a distance of 30 cm from the detector. After administration the 2L Nalgene waste container inside the beta shield is measured at a distance of 30 cm from the detector at four rotational positions and these four measurements are averaged. The percentage of dose delivered to the patient can be calculated using the following equation:

$$\text{Percentage of Dose Delivered (\%)} = \left[1 - \frac{\text{Waste Measurement after Administration}}{\text{Dose Vial Measurement before Administration}} \right] \times 100$$

where the Dose Vial Measurement is adjusted for the radioactive decay of Y-90 until the time that the Waste Measurement is made.

Instructions for TheraSphere® Infusion

The entire contents of the TheraSphere® dose vial are administered to the patient.

The administration instructions must be followed to optimize delivery of the calculated dose.

1. Items Required for TheraSphere® Administration

- Patient prescription for TheraSphere® (signed Written Directive)
- Ionization survey meter
- Geiger-Mueller (GM) contamination meter
- Spill kit
- A floor drape applied under the cart in the angiography suite.
- A sterile drape placed on the cart.
- Place the following sterile items on the draped cart:
 - Hemostat
 - Scissors
 - Sterile adhesive strips
 - Towels
 - Gauze



- Place the following items on the cart:
 - Administration Set (in packaging)
 - Verify the expiry date.
 - TheraSphere® Administration Accessory Kit (acrylic box)
 - Remove the top shield
 - Fully extend the stainless steel arm
 - Install the bag hook
 - Electronic dosimeter (RADOS RAD 60R or equivalent)
 - Turn the dosimeter on and set to mR/h
 - Clip the dosimeter to its bracket on the acrylic box
 - Saline bag (in packaging) or bottle (minimum 100 mL)
 - Alcohol swabs
 - 2L Nalgene waste container with beta shield
 - TheraSphere® dose vial, in lead pot

2. Administration Set Priming

- Open the Administration Set packaging and remove the Administration Set and 20 mL empty vial.
- Insert the white non-vented spike (CLEAR CAP) into the saline bag (or bottle). Hang the saline bag on the bag hook.
- Insert the white vented spike (BLUE CAP) into the empty 20mL vial.
- Remove the RED RUBBER cap shield cap from the needle injector assembly. Place the needle injector assembly on a sterile surface.
- If the 20 mL syringe is marked 'VacLok', turn the syringe plunger fully clockwise to ensure it is unlocked. (This step may not be required for an alternate syringe).
- Slowly fill and discharge the syringe to remove air from the Administration Set tubing and syringe. Continue priming vigorously with full pressure until there are no bubbles in the lines and there are continuous streams of saline flowing out of both needle holes in the needle injector assembly.
- Fill the syringe when priming is complete.

3. Dose Vial Preparation

- Lift the TheraSphere® dose vial in its lead pot and tilt the lead pot back and forth to 90 degrees to wet any microspheres on the vial septum. Tap the bottom of the lead pot firmly on a hard surface. Place the lead pot into the pot holder in the acrylic box base.
- Remove the lead pot lid and place it upside down on a non-sterile surface.
- Use a hemostat to remove the purple seal from the top of the dose vial acrylic shield. Discard the seal in the Nalgene waste container.
- Use a sterile adhesive strip to remove the dose vial acrylic shield plug. Discard the plug and sterile adhesive strip in the Nalgene waste container.
- Use an alcohol swab and a hemostat to swab the dose vial septum. Discard the swab in the Nalgene waste container.
- Record the dosimeter initial reading for the dose vial (mR/h).
- Measure and record the initial radiation field for the patient, using an ionization survey meter.



4. Final Assembly

- Close the pinch clamp on the outlet tubing near label 'E'.
- Place the empty 20 mL vial in the holder on the acrylic box and push the relief valve tube into gripper clip 'A'.
- Insert the needle injector assembly into the acrylic dose vial shield. Press on the GREEN cap to lock it in place. You will hear or feel a click or snap.
- Place the inlet tubing through slot 'B' in the acrylic box. Place the outlet tubing through slot 'D' in the acrylic box. Loop the tubing around the side and place the fitting into the holder at 'C'.
- Clamp the priming line at label 'C' with a hemostat (or equivalent).
- Push the YELLOW tabs on the needle injector assembly all the way down, locking the needles into the dose vial. You will hear or feel a click or snap at the bottom of travel.
- Ensure that the side shield is installed on the acrylic box. Place the top shield on the acrylic box with the sloped shield towards slot 'D'. Ensure that the tubing is not pinched or kinked.
- Move the cart close to the patient. Lower the bed to lowest position.
- Place a sterile towel under the extension arm holder 'E', and under holder 'C'.
- Place a sterile towel across the gap between the acrylic box and the patient.
- The Interventional Radiologist (IR) will flush the infusion catheter to ensure flow. Replace the infusion catheter if it is damaged or does not have satisfactory flow. Do not use a catheter extension or extra fittings. Replace the catheter if it is too short.
- Disconnect the outlet tubing labeled 'E' from the priming tubing at holder 'C'. Firmly connect the outlet tubing 'E' to the catheter.
- Place the catheter connection into the slotted holder 'E' at the end of the extended arm. Outlet tubing 'E' must be above the holder, with the infusion catheter hanging vertically below.
- The IR will verify the infusion catheter position.
- Release the pinch clamp from the outlet tubing. Dents in tubing may be reduced by rolling outlet tubing with fingers.

5. TheraSphere® Administration

ATTENTION: Beta radiation fields can be very high during microsphere transfer. Stand behind beta shielding or maintain distance.

- Record the starting time of the administration.
- Infuse TheraSphere® Y-90 glass microspheres using steady pressure on the syringe plunger. Infuse continuously until the syringe is empty (≥ 20 cc per minute).

NOTE: If the infusion pressure is over 30 psi, excess fluid will drip into the vented 20 mL vial. If this occurs, reduce the pressure being applied on the syringe until no flow is seen going into the vented vial. If the syringe flow is <20 cc per minute (i.e. appropriate to the flow of the native vessel) this may decrease the delivery efficiency of the administration system and result in higher residual in waste.

- Observe the outlet line and catheter for proper operation. If a problem is observed, inform the team and take corrective action.
- Re-fill the syringe for subsequent flushes by pulling back on the syringe plunger. A minimum of 3 flushes (60 cc total) are recommended. Continue flushes until the desired dosimeter reading is achieved.
- Record the number of flushes completed.
- Record the time that administration was completed.
- Record the final dosimeter reading.
- Measure and record the final radiation field for the patient using an ionization survey meter.



6. *Disassembly*

- Cut the inlet tubing at the indicated position.
- Remove the acrylic box top shield and side shield.
- The IR will remove the infusion catheter from the patient and lift the catheter connection out of the extended holder 'E'. Do not disconnect the catheter from the outlet tubing. Use care to control the tip of the infusion catheter and guide catheter as these may be contaminated with microspheres. Use gauze, a small towel, or hemostat to handle the catheters for radiation protection. Any item that has come in contact with microspheres is considered contaminated.
- Place all contaminated waste into the Nalgene waste container (in its beta shield), including the following:
 - Infusion catheter and guide catheter with attached tubing and towels/gauze
 - dose vial with attached needle injector assembly
 - lift the lead pot and dump out the dose vial.
 - contaminated items such as gauze, towels and gloves
- Cap the Nalgene waste container and place the acrylic lid on the beta shield. Remove for measurements to determine percent delivery and for disposal.
- Use a GM contamination meter to check IR's hands for contamination.
- Survey all staff leaving the room with the GM contamination meter.

7. *Cleanup and Waste Disposal*

- Use a GM contamination meter to check for contamination on the cart, lead pot, equipment, and the areas under the catheter connection and cart.
NOTE: Radiation from fluoroscopy, the patient, and the waste container will affect the ability to detect and measure contamination.
- Decontaminate and/or dispose of items as appropriate.
- As required, clean the TheraSphere® acrylic box with water, mild soap and a clean soft cloth. Alcohol wipes may be used (minimize alcohol contact with glued joints – alcohol degrades the glue over an extended time). Chlorine (bleach) disinfectants are also acceptable. Always use a clean soft cloth. **Do not use** industrial cleaner wipes, ammonia or abrasives to clean the acrylic parts.
- Replace the top and side shields on the acrylic box. Retract the extension arm and remove the bag hook. Turn off the dosimeter. Store the kit.



Troubleshooting

Problem	Action
1. Difficulty priming the Administration Set.	<p>If the 20 mL syringe is marked "VacLok": Verify that the syringe is not in a locked position.</p> <p>Verify that the tubing in the Administration Set is not pinched or kinked.</p> <p>Verify that the pinch clamp is not closed.</p> <p>The first priming flush should be performed very slowly to prevent small bubbles from forming in tubing and fittings. Subsequent priming flushes should be vigorous with full pressure.</p> <p>If saline leakage is observed, ensure connections are tight.</p> <p>If the issue cannot be identified and corrected, replace the Administration Set with a new one. Notify the manufacturer of the problem.</p>
2. Leakage that may contain microspheres.	<p>Attention: Any leakage from the dose vial, injector assembly, tubing 'D' through 'E', or the catheter connection at 'E' is likely to contain microspheres.</p> <p>Assess the extent of the leak. Ensure that the needle injector is properly inserted into the dose vial. If warranted, abort the infusion, disassemble the Administration Set and commence decontamination procedures. During decontamination, investigate the cause of the leak.</p>
3. Leakage of saline during infusion.	<p>Leakage observed from the syringe, the saline bag/bottle, or tubing lines 'A', 'B' and 'C' will only contain saline. If saline leakage is observed during TheraSphere® Administration, maintain steady pressure on the syringe. Do not stop the flush. At the end of the flush, address the saline leakage. Ensure that priming tube 'C' is clamped with a hemostat (or equivalent). Ensure connection to the syringe is tight. Adjust the saline bag or bottle connection.</p>
4. Blood begins to flow back to the TheraSphere® dose vial, when the catheter is connected and the syringe is not being pushed.	<p>This indicates that one of the fittings or the TheraSphere® dose vial septum is compromised. The procedure should be aborted if the issue cannot be identified and corrected. If issue has been identified and corrected, continue with administrations and observe the system for possible leaks (see Problem 2).</p>
5. Excessive fluid flow resistance is experienced during infusion or Difficulty achieving the desired dosimeter reading.	<p>If the 20mL syringe is marked "VacLok": Verify that the syringe is not in a locked position. Verify that the pinch clamp is open. Verify that the tubing between the syringe and dose vial are not pinched or kinked. Verify that the tubing between the dose vial and catheter are not pinched or kinked. Verify that the yellow tabs are pushed all the way down.</p> <p>Apply sufficient pressure on the syringe to cause fluid to flow into the pressure relief vial.</p> <p>Apply and release pressure on the syringe several times rapidly. This may clear a collection of microspheres at the tip of the outlet needle.</p> <p><u>Close the pinch clamp</u> before performing any actions with the catheter. Verify that there is no blood coagulation or damage in the catheter.</p> <p>Attention: There may be microspheres in the outlet line and catheter. Use standard radiation safety methods to assess the components before handling. Use remote handling tools as appropriate.</p>



BTG

RADIATION DOSIMETRY

The yttrium-90 in TheraSphere® is a constituent of an insoluble matrix thereby limiting irradiation to the immediate vicinity of the microspheres. The average range of the radiation in tissue is 2.5 mm. One GBq (27 mCi) of yttrium-90 per kg of tissue gives an initial radiation dose of 13 Gy (1,297 rad) per day. The mean life of yttrium-90 is 3.85 days; thus, the radiation dose delivered by yttrium-90 over complete radioactive decay starting at an activity level of 1 GBq (27 mCi) per kg is 50 Gy (5,000 rad).

HOW SUPPLIED

TheraSphere® is available in six dose sizes: 3 GBq (81 mCi), 5 GBq (135 mCi), 7 GBq (189 mCi), 10 GBq (270 mCi), 15 GBq (405 mCi) and 20 GBq (540 mCi). The dose is supplied in 0.6 mL of sterile, pyrogen-free water in a 1.0 mL vee-bottom vial sealed within a clear acrylic vial shield.

Preassembled single use TheraSphere® Administration Sets are provided. Each new user site is provided with a TheraSphere® Administration Accessory Kit containing re-usable components. The kit includes an acrylic box, a RADOS RAD-60R (or equivalent) radiation dosimeter and a beta shield for the waste jar.

HANDLING AND STORAGE

Each TheraSphere® dose vial contains one of six available dose sizes of yttrium-90, a high-energy beta emitter. Even with low-density materials such as the acrylic vial shield, the attenuation of beta particles gives rise to Bremsstrahlung radiation that requires lead shielding. Users should avoid exposure by leaving the vial in the acrylic product container, and by leaving the acrylic container in the lead shield unless required for measurement. Handle the dose in the acrylic shield with remote handling tools if removed from the lead pot. Finger-ring dosimeters should be worn in the orientation most likely to record the highest exposure to the fingers.

The TheraSphere® dose vial should not be removed from its acrylic vial shield. It should be stored in the lead pot and acrylic shield in which it is packaged. The TheraSphere® dose vial, TheraSphere® Administration Set, and TheraSphere® Administration Accessory Kit should be stored at room temperature. The requirements of the applicable regulatory agency for safe handling and storage of radioactive materials should be consulted and must be followed.

DISTRIBUTION

TheraSphere® is manufactured and distributed for Biocompatibles:



Biocompatibles UK Ltd, a BTG International Group Company
Chapman House
Farnham Business Park
Weydon Lane
Farnham
Surrey GU9 8QL
UK
www.therasphere.com

TheraSphere® is manufactured for Biocompatibles UK Ltd., a BTG International group company. TheraSphere® is a registered trademark of Theragenics Corporation, used under license by Biocompatibles UK Ltd. BTG and the BTG roundel logo are registered trademarks of BTG International Ltd. All rights reserved.

BIBLIOGRAPHY

1. Ehrhardt G.J., Day D.E. Therapeutic use of Y-90 microspheres. *Int. J. Radiat. Appl. Instrum. Part B. Nucl. Med. Biol.* 1987;14:233-242.
2. Mantravadi R.V.P., Spigos D.G., Tan W.S., Felix E.L. Intraarterial yttrium 90 in the treatment of hepatic malignancy. *Radiology* 1982;142:783-786.
3. Herba M.J., Illescas F.F., Thirlwell M.P., et al. Hepatic malignancies: improved treatment with intraarterial Y-90. *Radiology* 1988;169:311-314.
4. Houle S., Yip T.K., Shepherd F.A., et al. Hepatocellular carcinoma: pilot trial of treatment with Y-90 microspheres. *Radiology* 1989;172:857-860.
5. Blanchard R.J.W., Morrow I.M., Sutherland J.B. Treatment of liver tumors with yttrium-90 microspheres alone. *J. Can. Assoc. Radiol.* 1989;40:206-210.
6. Shepherd F.A., Rotstein L.E., Houle S., et al. A phase I dose escalation trial of yttrium-90 microspheres in the treatment of primary hepatocellular carcinoma. *Cancer* 1992;70:2250-2254.
7. Blanchard R.J.W., Grotenhuis I., LaFave J.W., Perry J.F. Jr. Blood supply to hepatic V2 carcinoma implants as measured by radioactive microspheres. *Proc. Soc. Exp. Biol. Med.* 1965;118:465-468.
8. Gyves J.W., Ziessman H.A., Ensminger W.D., et al. Definition of hepatic tumor microcirculation by single photon emission computerized tomography (SPECT). *J. Nucl. Med.* 1984;25:972-977.
9. Meade V.M., Burton M.A., Gray B.N., Self G.W. Distribution of different sized microspheres in experimental hepatic tumors. *Eur. J. Cancer Clin. Oncol.* 1987;23:37-41.
10. Chuang V.P. Hepatic tumor angiography: a subject review. *Radiology* 1983;148:633-639.
11. Andrews J.C., Walker S.C., Ackermann R.J., et al. Hepatic radioembolization with yttrium-90 containing glass microspheres: preliminary results and clinical follow-up. *J. Nucl. Med.* 1994;35:1637-1644.
12. Harbert J.C., Ziessman H.A. Therapy with intraarterial microspheres. In: *Nuclear Medicine Annual 1987*, edited by Freeman L.M., Weissman H.S., Raven Press, New York.
13. Ho S., Lau W.Y., Leung T.W.T., et al. Partition model for estimating radiation doses from yttrium-90 microspheres in treating hepatic tumors. *Eur. J. Nucl. Med.* 1996;23:947-952.
14. Lau W.Y., Leung T.W.T., Ho S., et al. Treatment of inoperable hepatocellular carcinoma with intrahepatic arterial yttrium-90 microspheres: a phase I and II study. *Br. J. Can.* 1994;70:994-999.
15. Leung T.W., Lau W.Y., Ho S.K., et al. Radiation pneumonitis after selective internal radiation with intraarterial 90-yttrium microspheres for inoperable hepatic tumors. *Int. J. Radiat. Oncol. Biol. Phys.* 1995;33:919-924.
16. Ho S., Lau W.Y., Leung T.W.T., et al. Clinical evaluation of the partition model for estimating radiation doses from yttrium-90 microspheres in the treatment of hepatic cancer. *Eur. J. Nucl. Med.* 1997;24:293-298.
17. Marn C.S., Andrews J.C., Francis I.R., et al. Hepatic parenchymal changes after intraarterial y-90 therapy: CT findings. *Radiology* 1993;187:125-128.
18. Wollner I., Knutsen C., Smith P., et al. Effects of hepatic arterial yttrium-90 glass microspheres in dogs. *Cancer* 1988;61:1336-1344.
19. Zeissman H.A., Thrall J.H., Gyves J.W. et al. Quantitative hepatic arterial perfusion scintigraphy and starch microspheres in cancer chemotherapy. *J.Nucl. Med.* 1983;24:871-875.
20. Leung W.T., Lau W.Y., Ho S. K., et al. Measuring lung shunting in hepatocellular carcinoma with intrahepatic-arterial technetium-99m macroaggregated albumin. *J. Nucl. Med.* 1994;35:70-73.

21. Nakamura H., Tanaka M., Oi H. Hepatic embolization from the common hepatic artery using balloon occlusion technique. *Am. J. Radiol.* 1985;145:115-116.
22. Dancey J.E., Shepherd F.A., Paul K., et al. Treatment of Nonresectable Hepatocellular Carcinoma with Intrahepatic ⁹⁰Y-Microspheres. *J. Nucl. Med.* 2000;41:1673-1681.
23. Russell J.L. Jr., Carden J.L., Herron H.L. Dosimetry calculations for yttrium-90 used in the treatment of liver cancer. *Endocurietherapy/ Hyperthermia Oncology* 1988;4:171-186.
24. Synder W.S., Ford M.R., Warner G.G., Watson S.B. "S" absorbed dose per unit cumulated activity for selected radionuclides and organs. NM/MIRD Pamphlet No 11. New York: Society of Nuclear Medicine 1975-1976.
25. Salem R., Thurston K.G., Carr B.I., Goin J.E., Geschwind J-F.H. Yttrium-90 microspheres: radiation therapy for unresectable liver cancer. *J. Vasc.Int.Radiol.* 2002;13:S223-229.
26. Steel J., Baum A., Carr B.I. Quality of life in patients diagnosed with primary hepatocellular carcinoma: hepatic arterial infusion of cisplatinum verses 90-yttrium microspheres (TheraSphere®). *Psycho-Oncol.* 2004;13:73-79.
27. Goin J.E., Dancey J.E., Roberts C.A., Sickles C.J., Leung D.A., Soulen M.C. Comparison of post-embolization syndrome in the treatment of patients with unresectable hepatocellular carcinoma trans-catheter arterial chemo-embolization verses yttrium-90 glass microspheres. *World J. Nucl. Med.* 2004;1:49-55.
28. Carr B.I. Hepatic arterial ⁹⁰ yttrium glass microspheres (TheraSphere) for unresectable hepatocellular carcinoma: Interim safety and survival data on 65 patients. *Liver Transplantation* 2004; 10, suppl 2: S107-110.
29. Geschwind J-F.H., Salem R., Carr B.I., Soulen M.C., Thurston K.G., Goin K.A., Van Buskirk M., Roberts C.A., Goin J.E. Yttrium-90 microspheres for the treatment of hepatocellular carcinoma. *Gastroenterology* 2004; 127; S195-205.
30. Kennedy A.S., Nutting D.O., Coldwell D., Gaiser J., Drachenberg C. Pathologic response and microdosimetry of ⁹⁰Y microspheres in man: review of four explanted whole livers. *Int. J. Rad. Oncol. Biol. Phys.* 2004;60; 1152-1163.
31. Sarfarez M., Kennedy A.S., Lodge M.A., Li X.A., Wu X., Yu C.X. Radiation absorbed dose distribution in a patient treated with yttrium-90 microspheres for hepatocellular carcinoma. *Med. Phys.* 2004; 31: 2449-2453.
32. Goin J.E., Salem R., Carr B.I., Dancey J.E., Soulen M.C., Geschwind J-F.H., Goin, K., Van Buskirk M.S., Thurston K. Treatment of unresectable hepatocellular carcinoma with intrahepatic yttrium-90 microspheres: Factors associated with liver toxicities. *J.Vasc.Int. Radiol.* 2005;16: 205-213.
33. Goin J.E., Salem R., Carr B.I., Dancey J.E., Soulen M.C., Geschwind J-F.H., Goin, K., Van Buskirk M.S., Thurston K. Treatment of unresectable hepatocellular carcinoma with intrahepatic yttrium-90 microspheres: A risk-stratification analysis. *J.Vasc.Int. Radiol.* 2005;16: 195-203.
34. Pirisi M, Avellini C, Fabris C, et al. Portal vein thrombosis in hepatocellular carcinoma: Age and sex distribution in an autopsy study. *J Cancer Res Clin Oncol* 1998; 124:397-400.
35. Kulik LM, Carr B, Mulcahy MF, Lewandowski RJ et al. Safety and efficacy of 90Y radiotherapy for hepatocellular carcinoma with and without portal vein thrombosis. *Hepatology.* 2008; 47(1):71-81.
36. Salem R, Lewandowski R, Roberts C, Goin J, et al. Use of yttrium-90 glass microspheres (TheraSphere®) for the treatment of unresectable hepatocellular carcinoma in patients with portal vein thrombosis. *J Vasc Interv Radiol* 2004; 15:335-345.

Diagram 2

TheraSphere® Administration Accessory Kit
(shown assembled with TheraSphere® Administration Set)

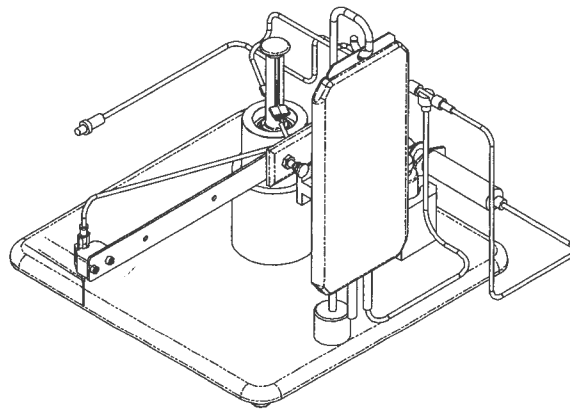
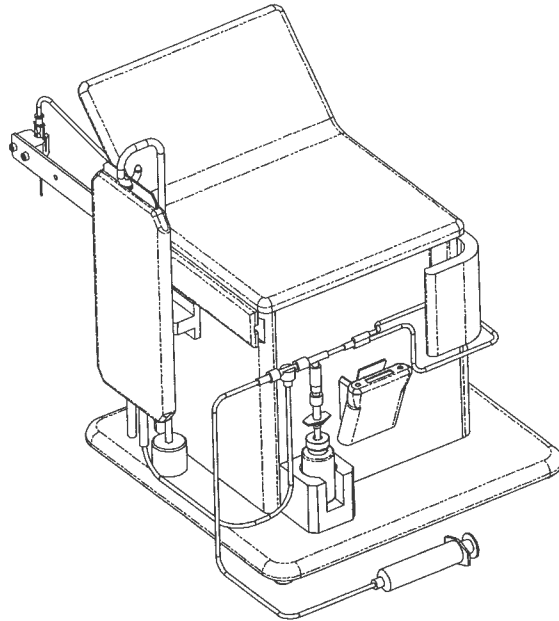

Diagram 3
Illustration of the Plunger Assembly Inserted into the Dose Vial in the Acrylic Shield

