



SOUND MATTERS

How to achieve acoustic comfort in the contemporary office

Produced by GSA Public Buildings Service

December 2011

PART 1

What Is Acoustical Comfort? 4

Why Is It So Important? 4

How To Deliver It? 4

The Current Situation – What Research is Telling Us..... 6

The Challenge – Why Acoustics is More Important Than Ever..... 9

The Solution – Checklist for Success 10

PART 2

A Closer Look at the Where and How of Acoustic Mitigation 12

WHAT: Behavior Works–The Human Element of Acoustics 13

WHERE: Zoning and Designing Workplace Neighborhoods 18

HOW: Technical Tips for Physical Acoustic Mitigation 28

Special Conditions & New Acoustical Treatments 37

Talk Like an Acoustician (or at least understand them) – A Short Glossary 38

Putting it all Together: Costs 40

References 41

Acknowledgements 42



This publication is dedicated to the unknown worker who, in response to a New York Times article, *Beyond the Cubicle*, by Allison Arieff, July 18, 2011, wrote the following internet comment:

“I currently work in a cubicle – my neighbors are a man in the midst of a divorce, a woman with a problem child, another woman with an elderly parent who should be in a care facility. The only cure for my personal hell would be a quiet room with a door. Perhaps my employer would then get his money’s worth from my workday... did I mention that I am across from the copier?”

This publication aims to show that there is a way out of this worker’s “personal hell” ... but without a room, and without a door. As the Federal Government transitions to greater density and less private enclosure for economic and organizational reasons, acoustic performance will need to transition from a “side issue” to a “core issue.”

INTRODUCTION

GENERAL SERVICES ADMINISTRATION (GSA) CENTER FOR WORKPLACE STRATEGY, PUBLIC BUILDINGS SERVICE (PBS)

The mission of the Public Buildings Service is to provide superior workplaces for federal customer agencies at superior value to the American taxpayer.

The Center for Workplace strategy plays a key role in delivering on that vision. It works with its Federal customers to provide them with innovative strategies, transforming the workplace into a catalyst for organizational effectiveness and efficiency. Through the development of tools, training, resources, and a nationwide network of subject matter experts, the Center works with its customers to craft requirements that support their mission and goals, with sustainability, flexibility, and the American taxpayer in mind.

The Office of the PBS Chief Greening Officer drives the implementation of sustainability practices and customer facing solutions to enhance the environmental performance of GSA's real estate portfolio and provide healthy and productive workspaces. The Office also leads GSA's Green Proving Ground, a program that aims to accelerate sustainable real estate through testing, evaluation, and adoption of innovative technologies and practices.

WORKSHOP OVERVIEW

This distillation of best practices was created with the input of educational, federal government workplace strategists (including PBS client agencies), together with behavioral and environmental psychologists and private-sector experts in the fields of acoustics. *Sound Matters* is produced by the GSA Center for Workplace Strategy, PBS with the support of the Office of High Performance Green Building and the Office of the Chief Greening Officer.

OTHER TOOLS ASSOCIATED WITH THE PUBLICATION THAT MAY ALSO BE OF INTEREST:

- Workplace Solutions Library (WSL)
- Sustainable Facilities (SF) Tool
- Leveraging Mobility, Managing Change
- The New Federal Workplace

PART 1

What is acoustical comfort?
Why is it so important and
how do you deliver it?

WHAT IS ACOUSTICAL COMFORT

Good office acoustics is a key contributor to work performance and well-being in the workplace. The ability to find quiet times and places is essential to support complex knowledge work, while the ability to have planned or spontaneous interactions without disturbing others is necessary for team work and relationship development. Having speech privacy is necessary for confidential interactions and work processes.

“Acoustical comfort” is achieved when the workplace provides appropriate acoustical support for interaction, confidentiality, and concentrative work. The foundation of acoustical comfort in the office is the “Privacy Index” (PI). As acoustical consultant Steve Johnson explains it:

“Imagine going into an office, closing the door and reading 100 words at random out of the dictionary. If your colleague in the adjoining office can understand 5 words out of 100, the office has achieved a PI of 95. This is the definition of confidentiality. Most commercial office buildings provide a PI less than 80. Sound travels from one space to the next through numerous weaknesses in the built environment. The sound of speech passes the union of ceiling and the wall and through lights and air conditioning components. Like water from a bucket with holes, the energy of sound finds every opening no matter how small.

A privacy Index of 80 defines normal privacy. This is an important threshold. Reaching a PI of 80 allows for a significant reduction in distractions. The 20% of words that can be understood does not provide sufficient content to break concentration and take workers off of their task. Normal privacy can be achieved in open work stations. Imagine a workstation that provides better speech privacy than most offices.”

With a mission to deliver “superior workplace at superior value for the US taxpayer,” PBS understands the importance of acoustic performance. Especially with today’s new ways of working, it is difficult to imagine a superior workplace which does not take acoustic performance into account. Furthermore, an acoustically uncomfortable workplace won’t represent the best value for the taxpayers since unwanted distractions inevitably degrade the effectiveness of *their* workforce.

Perhaps because sound is not visible, we tend to underestimate its importance. For instance, if water were leaking into a space rather than distracting sound, the building manager would be “on it” immediately! Sound leaks can be just as damaging to workplace function, but we are expected to dismiss them much more readily than a soggy carpet! We dismiss acoustic distraction at the expense of worker effectiveness and taxpayers’ investment in their workforce. The graphic on the next page translates sound into something we can see. The brighter the red, the higher the decibels (noise). The deeper the blue indicates the lower decibel rating.

WHAT IS ACOUSTICAL COMFORT?

FIG 1. TRANSLATING SOUND LEVEL INTO GRAPHICS

■ Loud ■ Quiet

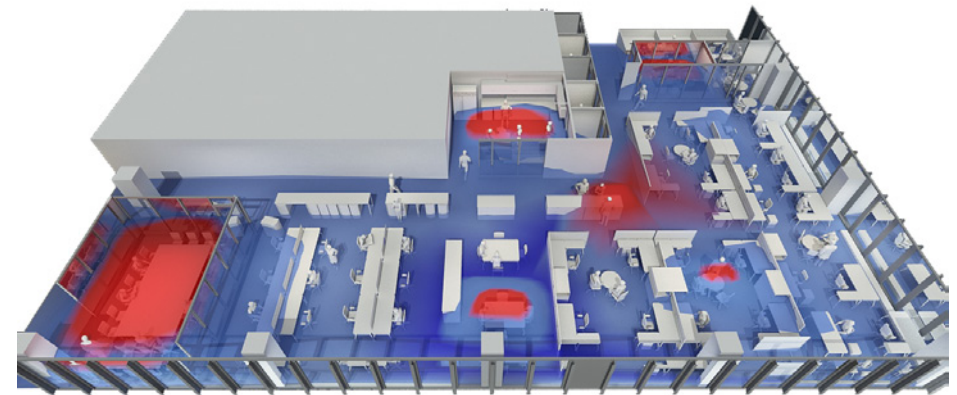
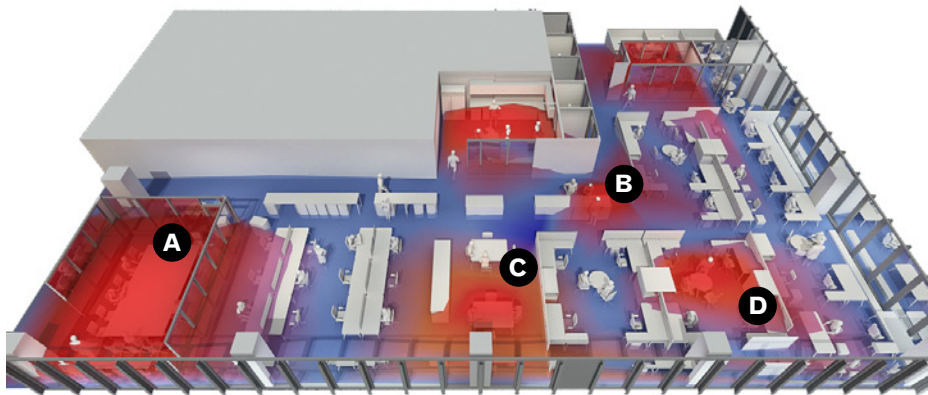

Workplace Distractions (letters refer to plan above)

- A. Conference room/teleconference.*
- B. Hallway discussion near workstations
- C. Informal meetings and conversations
- D. Employees on the phone (especially standing above the acoustic absorption of the workstation or on a speakerphone)

*This high level of noise is to be expected in a meeting area, but it may be a distraction to those outside the room who are uninvolved in the meeting itself.

Improved Acoustic Features

1. Low workstation partitions but with adequate seated privacy and acoustic absorption of NRC 0.7 in partition material located in front of the worker when seated, typically in any furniture partition.
2. High noise reduction coefficient (NRC) in the ceiling and/or on walls
3. A sound masking system
4. Enhanced employee awareness of co-workers

Sound Matters will demonstrate how uncontrollable distractions (shown as red on the left) can be mitigated—rendering greater acoustical comfort—as shown in the same workplace with more quiet (blue) on the right.

THE CURRENT SITUATION—What The Research Is Telling Us

At the present time, work environments are doing a poor job of providing acoustical comfort. Results from GSA's workplace research show that acoustic problems are a leading source of employee dissatisfaction in offices.

Fig. 2 at right shows the pre- and post- results from seven federal offices that were redesigned to better align with each agency's business goals and missions. All of the projects emphasized improved communication and collaboration as a means to achieve the agency's business goals. To support these goals, the physical environment in each of the projects shared a cluster of factors: lower workstation partitions to enhance visibility of work and people as well as to achieve LEED credits. They also include spaces for spontaneous meetings, more varied meeting rooms, and more social spaces. In some instances, the projects incorporated small enclosed rooms for privacy and concentration.

As can be seen in Fig. 2, there were substantial improvements in almost all environmental factors except noise and voice privacy. The percent satisfied with noise and privacy was even lower than for temperature conditions, which are notoriously dissatisfying. Similar results have been found in research on workplaces in the private sector.¹ It should be noted that satisfaction with acoustics was low even before the renovations. Acoustic conditions have been a concern since the adoption of the open plan office decades ago.

FIG 2. PERCENT SATISFIED WITH ENVIRONMENTAL CONDITIONS

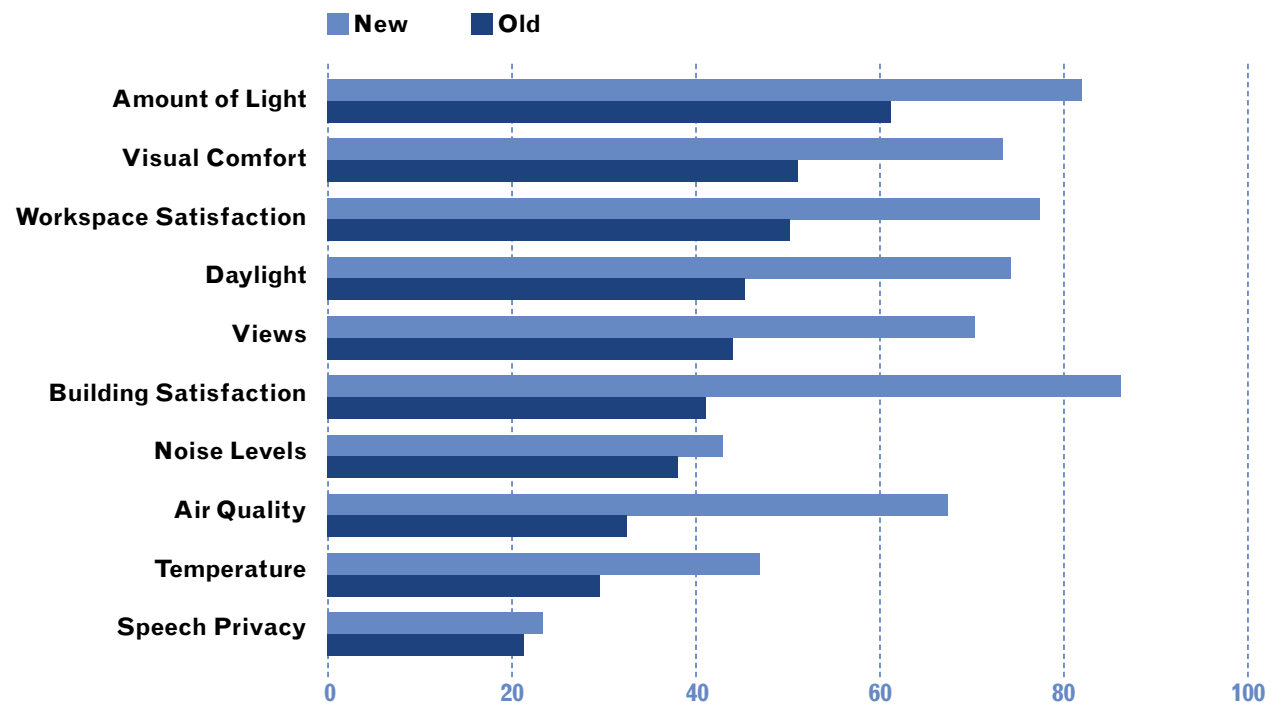

MYTH:

High cubicle partitions mean less noise, more privacy, and fewer distractions.

REALITY:

Not true. Research shows that higher cubicle partitions block standing line of sight but provide small amounts of additional acoustical shielding. But this increase in 'visual privacy' may encourage people to talk louder because they think they have more privacy. Unfortunately, there may be less privacy and more disruption.

¹Heerwagen, J., K. Kampschroer, K. Powell, and L. Loftness, 2004. Collaborative Knowledge Work Environments. *Building Research & Information*. 32(6): 510-528.

THE CURRENT SITUATION—What The Research Is Telling Us

PLANNING: COMMON MISCONCEPTION

The real noise problems are people having conversations with colleagues on the phone, in their workstations or in adjacent circulation areas. Because it is easier to see colleagues in a more open workplace, this generates more spontaneous conversation and more distractions for others doing quiet work. Both behavioral observations and survey results document this finding. Behavioral observations of a renovated GSA building in Philadelphia show that the number of interactions in workstations doubled in the new workspace due to the increased visibility of work.² In a baseline survey for the GSA WorkPlace 20•20 program (which provided research and pilot feedback that the Center for Workplace Strategy follows), slightly more than 60% of the 3700 respondents said they often stop and talk to colleagues in workstations or in nearby corridors and 60% said they get useful information by overhearing conversations. At the same time, the majority of respondents complained about the noise which they contributed to generating:

- 60% said they could get more done if it were quieter
- 56% said the ability to insulate themselves from distractions was very important
- 50% said noise keeps them from being as productive as they could be

² Rashid, M., K. Kampschroer, J. Wineman, and C. Zimring, 2004. Face-to-face Interaction in Office Settings: *What You Know About it May Not be Always True*. Technical Report, Georgia Institute of Technology, College of Architecture, Atlanta, GA.

VETERAN'S ADMINISTRATION SERVICE CENTER, RENO, NEVADA

This is one of seven workplace relocation projects whose results were studied and reported in Fig. 2.



BEFORE



AFTER

FIG 3. AVERAGE ACOUSTIC SATISFACTION SCORE, BY OFFICE TYPE

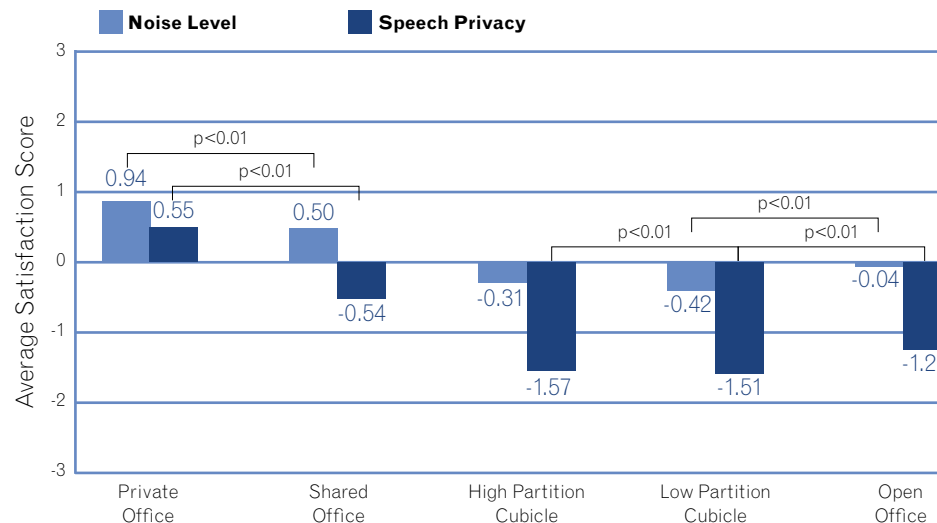

Results from a large (approximately) 24,000 worker survey which shows that there is no statistical difference between worker satisfaction in high or low cubicle partition situations. In fact, no partitions scores better. Enclosed offices are good, but are only .55 on a scale out of a possible +3 for speech privacy. Finally, the graphic shows much greater dissatisfaction with speech privacy than with noise intrusion.

THE CURRENT SITUATION—What the Research is Telling Us

PLANNING: COMMON MISCONCEPTION

Despite the problem with distractions and voice privacy, collaboration is often improved in more open workspaces. The GSA WorkPlace 20•20 research shows that workers rated new, more open environments as better for communication and collaboration within and across groups than previous workspaces with higher panels and fewer interaction spaces.³ Fig. 4 summarizes the results.

FIG 4. PERCENT SAYING THE NEW WORKPLACE IS BETTER THAN THE OLD WORKPLACE FOR SPECIFIC BEHAVIORS

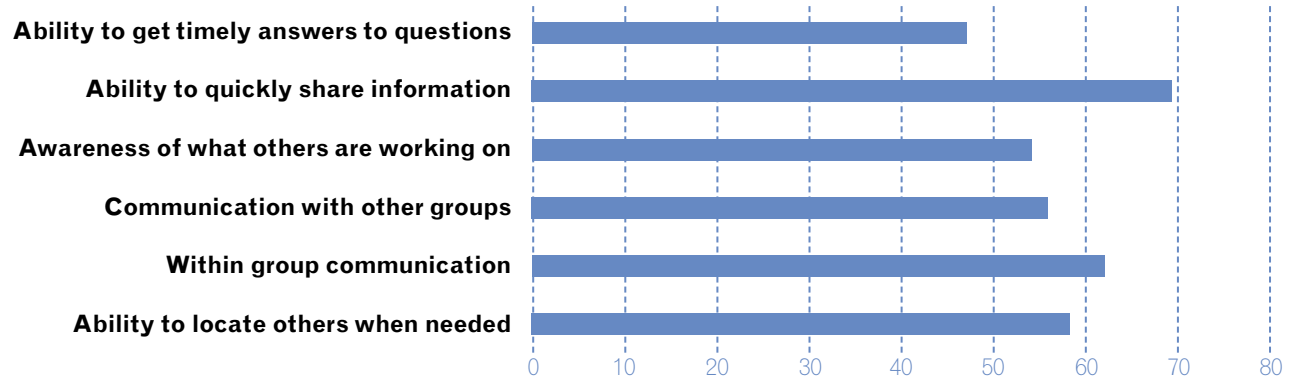

³White paper: *The New Federal Workplace*, June, 2009.

THE CHALLENGE —Why Acoustics is More Important Than Ever

Work and workplace have changed. To deliver on its commitment to provide “Superior Federal workplaces at superior value for the taxpayer,” PBS should reflect these changes in workspaces it provides to its clients. Organizations want to improve collaboration and flexibility while also reducing the environmental impact of the office through greater density. These goals result in workspaces that are more visually open to enhance communication and daylight access, more flexible to promote easy reconfiguration of furnishings and spaces, and more socially focused with a variety of meeting and interaction spaces. Contemporary, sustainably-designed workplaces also typically feature more densely occupied office space with less private space in lieu of more collaborative space. All of these factors, combined with the great dissatisfaction with acoustics performance (as shown in Fig. 2) underscore the need for effective integrated strategies in the design and retrofit of workplaces. Today’s work thrives on interaction – ranging

from quick conversations to spontaneous and unplanned meetings. Clearly, employees value the opportunity to communicate more effectively as Fig. 2 shows. Yet it comes at a cost. The very workplace features that foster communication and interaction contribute to dissatisfaction with voice privacy and concentration.

The challenge addressed in *Sound Matters* is to identify ways of reducing distractions and enabling speech privacy without impairing the benefits of interaction. This can be accomplished with better planning, application of basic acoustic principles and techniques, use of technologies that aid movement to spaces most conducive to current needs, and ways to enhance adaptation to new spaces through behavioral and policy changes.

MYTH:

If a room has a door and it is closed, conversations within will be private.

REALITY:

Not always true. Rooms with closed doors can keep conversations private only if adequate measures have been taken in construction to prevent sound from leaking around doors, through walls, through the ceiling plenum, through ducting, etc. Never assume that a closed-door conversation is confidential without checking first. Special “secure” rooms can be built where needed and have been used in embassies and military facilities for decades.

THE SOLUTION(S)—Checklist for Success

The Facility Standard for the Public Building Service (PBS P-100) gives very usable technical specifications for acoustic mitigation methods, and nothing in *Sound Matters* should be seen as contradicting it. But the existence of obvious dissatisfaction with acoustics illustrated by Fig. 2 shows that P-100 criteria may not always be applied in practice, leading to spaces that do not perform as intended. To be optimally effective and affordable, integrated acoustic design requires that acoustics be considered at the beginning of the design process – not “fixed” afterward.

Sound Matters describes ways to ensure that office workers will have the privacy and acoustical comfort they need to be effective. It summarizes solutions developed during an intensive two-day workshop sponsored by the PBS Center for Workspace.



An acoustic charette was convened at the National Institute of Building Sciences (NIBS) to provide guidance to PBS.

The workshop included leading technical experts, industry representatives, behavioral scientists, and federal GSA-client agency representatives. There are three key areas of equal importance which need to be addressed to create acoustic comfort:

- Behavior
- Design
- Acoustic Treatment

Consistently integrating all three areas will deliver a workplace that is comfortable, sustainable and supportive of both interactive and quiet work.

Even though good acoustics is a key contributor to interior quality - along with lighting, thermal conditions, ergonomics, and air quality – it is often an after-thought rather than an integral component of the contemporary workplace. Acoustic quality is even more critical today with aggressive federal goals to eliminate unused space⁴ and to achieve sustainability goals⁵ in new and renovated buildings. Reduction in space will lead to more intensely used workspace which may exacerbate current acoustic problems.

In addition, sustainable design requires attention to materials used in furnishings and construction. Materials that achieve sustainability goals may not be the best choice for acoustic comfort. Goals to decrease energy use by enhancing daylight penetration can also inadvertently create acoustic problems associated with lower workstation panels which offer fewer opportunities for sound absorption.

Concurrently, it has also been observed that the greater visibility of lower workstation panels increases the consideration of fellow workers when the occupant is aware of others in the space. Seated visual privacy strategies in smaller workstations with correspondingly larger or more frequent conference and support spaces can be more easily accepted when workers and their representatives realize how ineffective distance is at mitigating sound and how the greater visual separation from co-workers privacy of traditional workstations may make speech privacy far worse.

The basic scientific principles of acoustics have been known for some time, and for particularly difficult situations such as auditoria and restaurants, the services of acousticians are regularly enlisted. This is not always the case with GSA projects, however.

⁴Presidential memorandum on the disposal of unneeded federal space , June 10, 2010

⁵Executive Order 13514

THE SOLUTION(S)—Checklist for Success

TEN STEPS TO ACHIEVING ACOUSTIC COMFORT IN THE CONTEMPORARY OFFICE

Although acoustics has long been recognized as a critical component of sustainable design, acoustic expertise is generally missing from the discussion. The best way to mitigate contradictory goals to achieve a good solution is to integrate multi-disciplinary expertise from the beginning. *Sound Matters* is intended to change the current situation by putting acoustics on the table from the beginning of the project using the practical knowledge embedded in these guidelines. *Sound Matters* provides design teams with acoustic know-how that can be readily integrated into office planning. For most GSA work places, acoustic performance will be remarkably enhanced by attending to the guidance in *Sound Matters*. This document provides details and examples of how to improve acoustical comfort in today's office. **To increase the likelihood of acoustical design success and to avoid the need for expensive retrofits, the advice on the following pages should be considered by GSA personnel, architects, user groups, and others involved in the project. Furthermore, in scopes of work, it is recommended that *Sound Matters* be referenced with the requirement that designers “check off” items in TEN STEPS TO CONSIDER IN ACHIEVING ACOUSTIC COMFORT IN THE CONTEMPORARY OFFICE, thus ensuring that they are a factor in the final design.**

- 1. Work patterns** – Identify the balance of concentration and interaction among the workers in the office to help create zones. Reference PBS's Workplace Solutions Library (WSL) which has a survey to determine this.
- 2. Speech Privacy** – Identify the level of privacy required for the work based on the work patterns in the WSL.
- 3. Behavioral change** – support behavioral adaptations with mobile technologies, multiple work spaces, and policy.
- 4. Behavioral protocols** – develop protocols with the participation of the subject work group, aimed at reducing distractions and appropriate use of space use.
- 5. Zoning** – After determining the work patterns, (see #1 above, under “Behavior”), develop a layout strategy which will locate incompatible functions apart from each other. Locate conference and focus rooms convenient for interactive workers to “duck into and to act as barriers between various work patterns. Consider elements such as file banks to further separate incompatible functions.
- 6. Planning** – Carefully consider the effect on neighboring workstations when locating supporting activities such as copier rooms, coffee bars and entries to conference rooms where a queue could be anticipated – adjacent to large conference rooms, for instance.
- 7. Furniture** – Select furniture which complies with LEED NC credits EQ 8.1 and 8.2 to obtain 1 or 2 LEED credits. The low partitions required will achieve the desired access to natural light and view while allowing occupants to be aware of other nearby workers. Where a workstation partition is in front of the worker when seated at the desk, the noise reduction coefficient (NRC) of the partition should be .07 so that speech is not reflected backward when the worker seated at his or her desk speaks. Where possible, the layout should locate the desks so that workers will not be speaking directly “at” each other.
- 8. Sound Absorbing Ceilings and Walls** – Specify ceilings having a minimum NRC of 0.9 in open plan office areas and NRC 0.8 in meeting rooms and training facilities. In conference, meeting and training facilities, provide absorptive panels on 25% of walls with a minimum NRC of 0.8.
- 9. Sound Masking Systems** – Specify sound masking systems, particularly in open plan office areas. See page 42 for information regarding sound masking systems.
- 10. Walls** – Specify Sound Rated Wall Constructions as follows:
 - >STC 53 minimum to isolate video conference and training rooms.
 - >STC 45 minimum to separate conference rooms and executive office areas requiring confidential speech privacy.
 - >STC 40 minimum to separate private offices required in normal speech privacy.

PART 2

A Closer Look at the What, Where and How of Acoustic Mitigation

A systems approach is useful to integrate planning, design, specification, and construction of acoustical conditions. The decision framework described in this section is organized around simple steps in the following three areas:

WHAT

WHAT behaviors are appropriate, based on work pattern analysis and knowledge of the impacts of acoustic discomfort on work performance.

WHERE

WHERE to house groups with different work patterns: zoning and designing workplace “neighborhoods” based upon how much workers need to concentrate or how much they need to communicate to get their work done.

HOW

HOW to apply acoustical treatments, including ways to block, absorb and cover disruptive sound. We may not be able to achieve ideal acoustics, but we can significantly improve them with the practical wisdom discussed in this section of the document.

WHAT: BEHAVIOR WORKS–The Human Element of Acoustics

The best way to understand the behavioral aspects of acoustics is to look at the noise system as illustrated in Fig. 5 on the following page. People generate noise by talking, the noise follows pathways that enable sounds to be heard by others nearby. Acoustics is the science of understanding and controlling the transmission of noise. Strategies that address the path element seek to lessen the decibel level of the signal (absorb it or let it “run out of steam”) or simply interrupt it. See the “How” Section for potential strategies.

As noted previously, all work involves both interaction and quiet focus. Even in the most highly interactive work processes (such as creative brainstorming or problem solving), people need time to work on individual tasks that contribute to overall team effectiveness. The same is true of the most intensely individual work (such as writing and analysis) which needs interaction with others to gather information or test and validate ideas.

Because these two types of work styles – focus and interaction – are mutually exclusive, people need to adjust their behaviors to achieve acoustical comfort. The environment can provide the physical foundation for achieving acoustical comfort, but it cannot succeed on its own. That is why behavior is a critical step in achieving acoustical comfort.

Distractions from people talking are the biggest problem with office noise. In an ideal work world, people wouldn't talk in the quiet work areas. However, actual work moves readily between quiet and interaction. People get phone calls they must deal with. They need a quick conversation with a colleague to move a task forward. They talk to others nearby for both social and work reasons. Behavioral observations in work environments show that most people have small blocks of uninterrupted time, punctuated by frequent, brief conversations.⁶ Furthermore, the vast majority of interactions at work are opportunistic rather than planned, and they often occur as people encounter one another when moving around the office.⁷ But simple actions, such as standing at one's workstation rather than sitting, contribute to unwanted noise because there is probably less partition material to absorb the speech sound created. These kinds of behavior cannot be “controlled” but creating protocols agreed upon by the entire group may make workers more aware of behavior that interferes with others. It also relieves individuals from being in the role of “sound police.”

MYTH:

I can have private conversations in the “open workplace” workplaces.

REALITY:

Speech is unintelligible to causal listeners only when the following conditions exist: voices are low; designers have ensured that relatively high levels of background sound levels are continuously present; and sound absorbing material has been applied to most surfaces above, behind and around the talkers so that conversation is not reflected into surrounding spaces. If a conversation is truly intended to be confidential, it should take place in a fully enclosed room.

⁶ Backhouse, A., and P. Drew, 1992. *The Design Implications Of Social Interacting in a Workplace Setting*. Environment and Planning B: Planning and Design. 19: 573-584.

⁷ Penn, A., J. Desyllas, and I. Vaughn, 1999. *The Space of Innovation*. Environment and Planning B: Planning and Design. 26: 193-218.

Rashid, M., K. Kampschroer, J. Wineman, and C. Zimring, 2004. Face-to-face Interaction in Office Settings: *What You Know About it May Not be Always True*. Technical Report, Georgia Institute of Technology, College of Architecture, Atlanta, GA.

WHAT: BEHAVIOR WORKS–The Human Element of Acoustics

1. Signals: People talk with each other as a normal part of their work. This creates “noise” for other people. Yet communication and collaboration are an increasing requirement to accomplish our work. While some noise is created by office machines, such as printers, research shows the biggest source of disruptive noise is conversation. Strategies that address the signal tend to block or mitigate noise generation itself, absorb it, envelop as part of overall ambient sounds, or cluster noise generators to lessen impacts. An approach called the “ABC’s” of noise control – Absorb, Block, Cover.

2. Paths: The signals carry along a path to get to someone else. Distance and other elements can be used to mitigate the impact of the signal. But creating distance is difficult because people are now six to eight feet apart at their desks and up to twelve feet on center would be required to realize any appreciable reduction in distraction. Noise control strategies that address the path reduce the decibel level of the signal by blocking it, absorbing it, or letting it “run out of steam” over distance.

3. Receivers: Someone then hears the “noise” – the receiver. Sometimes the receiver wants to hear what’s being said, but often it is a distraction that interrupts their work. Strategies that address receivers are very similar to those that address senders: block the noise with barriers; add absorptive material; mask the noise with non-disruptive background sound; and cluster quiet-seeking receivers together. Because individuals have different sensitivities to noise – some are less distracted and some are more distracted by “noise,” individual control is valuable. The vast increase in mobile work patterns, and their supporting technologies, is a significant contribution to mitigation strategies at the receiver end. People who need quiet simply move to a work setting that is acceptably quiet.

FIG 5. HOW SOUND WORKS

Some workers are not disturbed by this sound dynamic. But for those who are, new ways of working allow them to move their location.

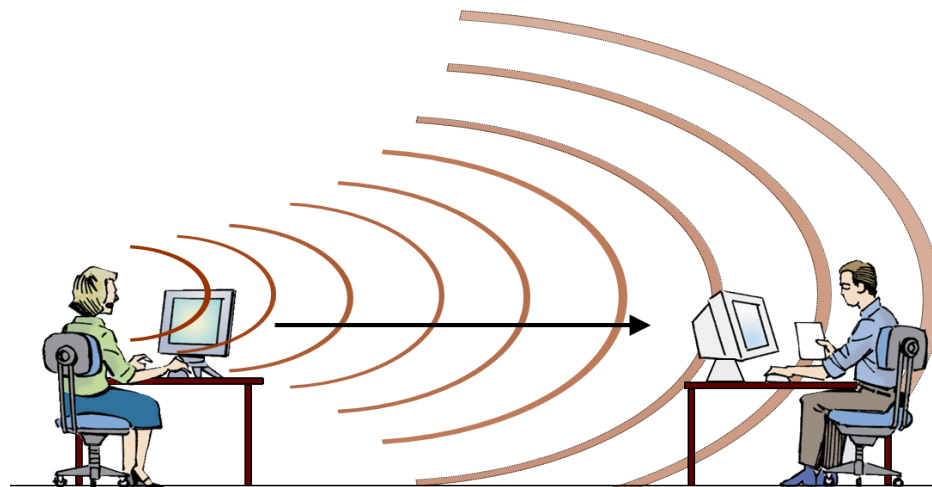

SIGNAL.....PATH.....RECEIVER

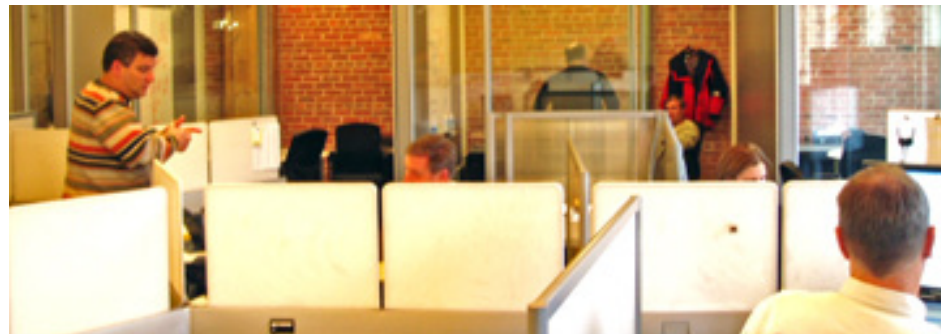

WHAT: BEHAVIOR WORKS–The Human Element of Acoustics

Why should we care so much about distractions?

Distractions are not just a source of annoyance and acoustic dissatisfaction. Distractions and interruptions also make it more difficult to do work. Specifically, research shows that distractions result in:

- Shifts in attention that reduce focus;
- Increased efforts to concentrate, which can increase stress levels and fatigue;
- Abandoning a current task to deal with demands caused by an interruption;
- Losing flow of thought and the need to re-orient to the task, which can take up to 15 minutes.

Research also shows that distractions and interruptions are most detrimental for complex cognitive tasks with high information processing demands.⁸



The 1980's "cubicle" lives on as a fictitious room – and conveys fictitious privacy. Because the visual cues say "room," occupants behave as though they are in a private room and tend to speak accordingly – sound goes right over the partition – easily distracting neighbors.

MYTH:

Speech privacy means "I can't hear you talking" or "I can't see you when you're talking."

REALITY:

Not true. Speech privacy is defined as "Techniques... to render speech unintelligible to casual listeners." This definition is the foundation of enforcement procedures used for speech privacy under privacy laws such as those in the Health Insurance Portability and Accountability Act (HIPAA).

WHAT: BEHAVIOR WORKS–The Human Element of Acoustics

THE NEED FOR SPEECH PRIVACY

Although the need for speech privacy is intermittent, the setting needs to provide acoustical conditions that support various degrees of speech privacy. As defined in Part 1, speech privacy refers to a condition in which people cannot fully hear or understand the words spoken by others located nearby. Several levels of speech privacy are defined in the ASTM standards:

- *Normal Privacy* – This term means that some percentage of anything that is said may be understood by a casual listener. There are many types of information that are either less sensitive or require hearing the whole conversation to understand it. This is normal privacy: you cannot understand the whole conversation. Normal privacy is the baseline for achieving acoustical comfort in most “open” offices.
- *Confidential Privacy* – Some information is wholly confidential. This term means that about 2% of anything that is said may be understood, but that the meaning of conversation cannot be determined by a casual listener. It is extremely difficult to achieve this level of privacy in an “open-landscape” office. Therefore, it is essential to design enclosed rooms that use the design strategies in Part 3: Detailed Acoustical Treatments.
- *Secure Privacy* – This term means that 0% of anything that is said can be heard or understood by an unaided listener. This is the most difficult and expensive level of speech privacy to achieve. Because of its specialized applications, it is not covered in these guidelines.

These levels can be related to ranges of the privacy index (PI) representing each level of speech privacy. Understanding 2 out of 10 words will render normal speech privacy, understanding 5 out of 100 words will render confidential speech privacy.

TO HEAR AND BE HEARD

Although much attention is paid to voice privacy and reducing office distractions, speech intelligibility (being able to understand what is said) is also an important workplace goal even though it is far less of a problem in open office space than speech distractions. Plan to enable speech intelligibility where it is required most, for team meetings in small conference rooms to all-hands meetings or huddles in shared open spaces and, most typically, in formal conference rooms. Attending to speech intelligibility will also address the needs of the hearing impaired. Appropriate design needs to take into consideration room configuration, and selection of surface materials, including ceiling, wall, flooring and window treatments. The amount and placement of absorptive and reflective finish is discussed in detail in Part 3. Achieving speech intelligibility may require speakers and microphones that clarify and amplify rather than block or cover (mask) sound. Consequently, it is essential to properly separate areas designed for speech intelligibility from those that require speech privacy. Additionally, consider that acoustics also aid the blind in navigating the workplace environment. Reference the American Disabilities Act (ADA) and Architectural Barriers Act (ABA).

SUPPORTING BEHAVIORAL CHANGE FOR ACOUSTICAL COMFORT

Behavioral change requires more than new workplace rules. Supports should include an integrated suite of approaches that support mobility as well as productive work in individual workstations. The overall workplace strategy to achieve acoustical comfort should include the following:

- **Technologies:** Provide mobile technologies that enable workers to move easily to a new location. This includes laptops, smart phones, Voice over Internet Protocol (VOIP), wireless connectivity, and ample plugs for computers. Also provide phone headsets for people who need to take calls at their desk and noise cancelling headsets for those who do not want to move to a new location in order to concentrate.
- **Space:** Provide small focus rooms or shared quiet areas (such as a reading room) where workers can focus without distractions. When zoning space, allow for choice in workstation location. Some people are better able to screen out distractions than others. Those most bothered, should be located in spaces farthest from noise generating activities.
- **Policy:** Allow eligible employees to work from home or from another location when they have tasks that require intense focus.
- **Protocols:** Work with employees to develop protocols to help adaptation to the open office. Frankly “airing” the potential problems alleviates many workers from the fear of appearing impolite which may keep them from registering by having agreed upon, public protocols (See an example protocol in Table 1.)

WHAT: BEHAVIOR WORKS–The Human Element of Acoustics

TABLE 1. EXAMPLE PROTOCOL FOR BEHAVIORAL ADAPTATION

These actions should be discussed in an all-hands forum to maximize understanding and acceptance.

Speak in a low, normal voice. (This is easier when one can see other occupants of the space rather than in the fictional privacy of a “cubicle” with high partitions.)

Keep phone conversations short or move them to an enclosed room. (Rooms for these kinds of calls need to be convenient and not “out of the way,” or workers will not use them).

Schedule lengthy calls for enclosed rooms with speaker phones.

If you know you will need access to a computer during a scheduled call, plan to use your laptop which can be moved readily to an enclosed room.

Do NOT use speaker phones at your desk in the open office. If needed, headphones with voice piece are an acceptable alternative if the voice can be kept at a normal level.

Limit conversations in the open workspace; hold meetings behind closed doors or in public spaces away from the open workstations. Be particularly aware of workers who are adjacent to main circulation paths.

Be aware that lengthy hall conversations before and after meetings can be heard by desk workers nearby. Where possible, locate conference room entries away from workstations to allow communication that occurs before and after meetings.

Look before you interrupt; if someone appears to be concentrating, come back later or use an alternative means to communicate such as e-mail or mail chat features.

Avoid noise spill by closing meeting room doors, especially when meeting rooms are located adjacent to the open plan work areas.

WHERE: Zoning and Designing Workplace Neighborhoods

PLANNING STRATEGIES

Acoustic planning strategies incorporate spatial factors and technologies into an overall approach to achieve acoustic comfort and to support the work of the office. The design team uses the information obtained in the first analysis step (identifying needs for interaction, privacy and concentration) and then applies the concepts of zoning, neighborhoods, and location choice.

ZONING

The basic zoning principle is simple: keep the noise generators away from work that needs a quieter environment. Anyplace where people collaborate frequently, including open meeting areas, conference rooms, break rooms, and common printer stations are noise generators. Within the open plan space, separate people who need to interact regularly from those who tend to do more individual work. In addition to the work areas, public areas also need to be considered. Large spaces, such as lobbies, reception, and cafeterias, are often noisy spaces that should be acoustically isolated from adjoining open workspaces. Depending on the nature of the public or common use areas, successful acoustic separation may be achieved with simple wall construction, or may require more advanced assemblies to achieve sufficient acoustic separation from the adjoining work area. Acoustical separation should also occur between high traffic corridors or circulation pathways and adjoining open work areas. Particularly in large facilities, corridors and primary circulation pathways can generate a significant amount of noise, and should be acoustically separated from adjoining workspaces.

FIG 6. ZONING CONSIDERATIONS

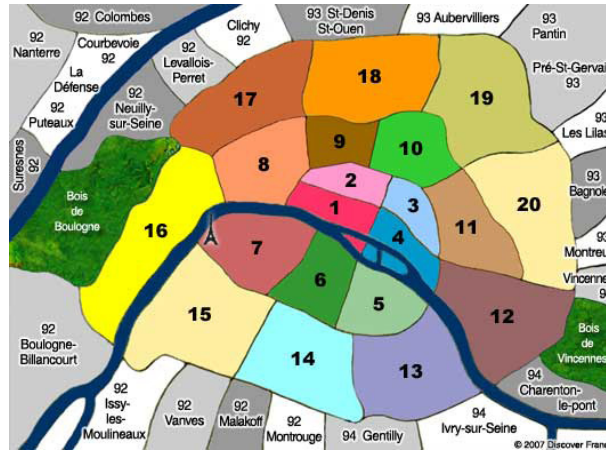

Zoning has been used by cities to ensure compatible adjacent uses. Office zoning aims at the same goal



Where quiet is important, why not just say so?
Courtesy of Hewlett Packard



Cluster people who do the same work together.



Separate open meeting areas from people who need quiet.

WHERE: Zoning and Designing Workplace Neighborhoods

Consider placing entrances to potentially very noisy activities such as the entrance to conference rooms away from areas where heads down work occurs.

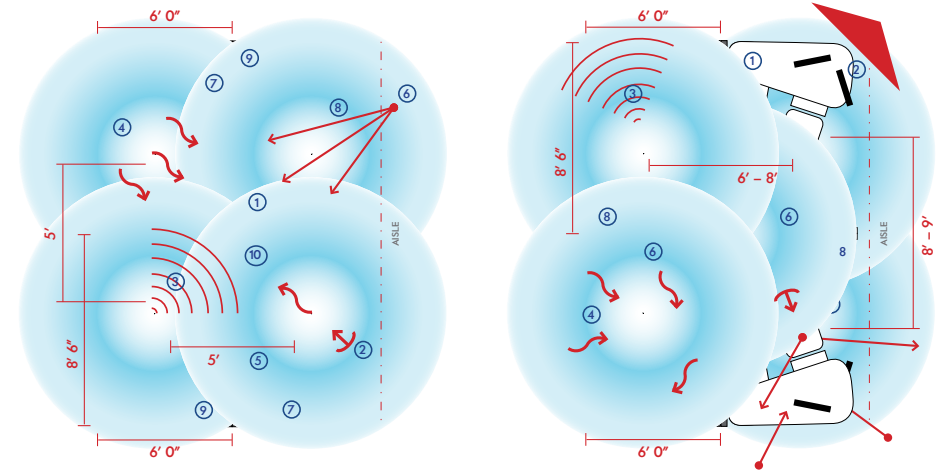

MYTH:

Sliding doors are as good as swinging doors to isolate sound within enclosed rooms.

REALITY:

Not true. Most sliding doors are much less effective at blocking sound. Why? Hinged doors typically have better seals that hold sound in – and keep it out – when they are closed. Good sliding doors are available, but may cost more because they are harder to seal.

MYTH:

If only my cubicle were bigger – then I would have acoustic privacy!

REALITY:

To gain any appreciable speech privacy, workers would need to be seated at 12'-0" on centers, which is not a realistic solution given the real estate and carbon footprint implications. Additionally, distance alone is not a very effective form of mitigation. As a rule of thumb, doubling the distance will only drop the decibel level a receiver hears from the sender by 5 points. This is barely perceptible.

WHERE: Zoning and Designing Workplace Neighborhoods

VISUALIZING ACOUSTICS - ACOUSTIC TOPOGRAPHIES

Graphics such as those illustrated in Fig. 7 at right help to visualize the invisible energy embodied in sound. The acoustic environment can be described as a “topographic” map where spikes of “noise” become very apparent. The diagrams at right show office noise measured in decibels (dB) and translated into different intensities of color. They illustrate both the impacts of “interaction noise” and the opportunities for mitigation using solutions described in *Sound Matters*. From an organizational and planning perspective, the topographical map in Fig.1 on page 5 and those at the right in Fig. 7 reveal ways to consolidate noise sources to create larger ‘neighborhoods’ of blue low-noise areas for people who require more quiet for concentration. The diagrams also show that mitigation strategies used in the open plan spaces (e.g., improved absorption and masking) can reduce sound levels and improve speech privacy. The specific solutions are described in subsequent sections.

The acoustic topography diagrams shown on this page illustrate both the impacts of “interaction noise” within the environment and the opportunities for addressing those impacts through the guidelines defined in the front section. Note that in each case the background (acceptable) acoustic environment is illustrated in blue and “noisier” areas are shown in varying shades of red depending on the noise level. From a design and organization perspective it becomes clearer how to consolidate noise generators so that the blue areas of less acoustic impact can become larger.

The acoustic environment can be mapped topographically using decibel (dB) levels as the vertical measure. The dB sources modeled in these diagrams are those commonly found in the contemporary workplace: speaker phone use in the conference room; the loud person standing up talking on their cell phone; normal speech at one’s desk; socializing in the break room.

Acousticians predict voice privacy levels by understanding the decibel level of the voice relative to the ambient noise levels in the work environment. The coloration of the diagram below shows the areas where normal voice privacy is achieved (blue areas) and is not (red areas).

FIG 7. IMPROVING NOISE LEVELS AT THE WORKSTATION

The background (acceptable) acoustic environment is illustrated in blue while “noisier” areas are shown in varying shades of red depending on the noise level. By addressing the impacts of “interaction noise” discussed in these guidelines, noise generators can be consolidated so that blue areas of less acoustic impact can be increased

■ Loud ■ Quiet

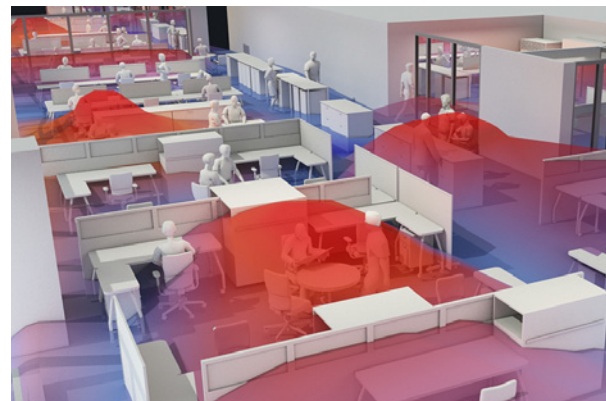

BEFORE

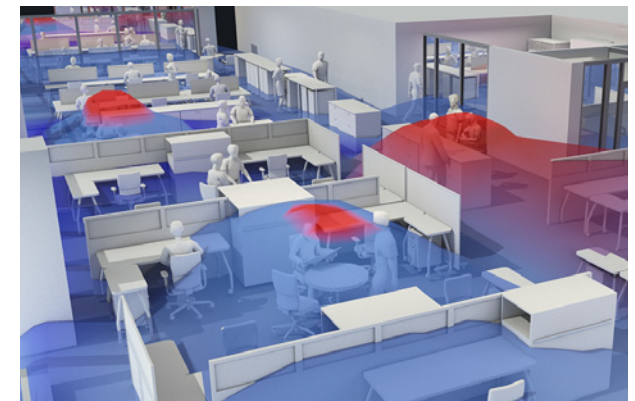

AFTER

WHERE: Zoning and Designing Workplace Neighborhoods

THE BAZAAR AND THE LIBRARY: TWO EXAMPLES OF DIFFERENT ACOUSTIC SETTINGS

During the acoustics charette in Washington DC, one participant characterized the difference between the interactive/noisy mode and the concentrative/quiet mode as similar to behaviors in a library or a bazaar.

The contrasting needs of the modern workplace can be seen as “The Bazaar” and “The Library,” with different acoustic needs and responses appropriate for each. In the recent past, workplace designers have conceived of all workplaces as libraries. What is the traditional workstation if not a library carrel grown large or a fictitious room (with corresponding fictitious privacy)? But the library approach is often at odds with the collaborative (bazaar-like) activities which are also integral to the current workplace.

Like a thriving urban environment, workplaces need both “bazaars” and “libraries.” One is not “better” than the other. Expectations of noise and speech privacy differ according to whether a workplace area is meant to function more like a bazaar or a library. For instance, as Fig. 8 at right shows, a range of behaviors are expected even within the library and the bazaar.

FIG 8. ANALOGIES FOR THE CONTEMPORARY OFFICE

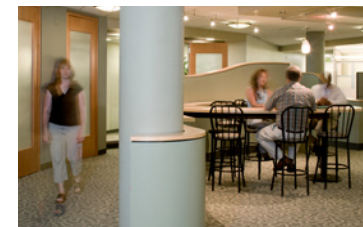
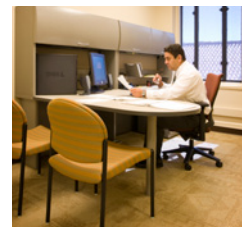

“**The Library**” is an analogy for a workplace environment where both quiet and speech privacy are expected to optimize the ability to concentrate. Sound masking is designed to ensure sound privacy but sudden outbursts would be considered inappropriate and disruptive. If a space is too quiet, even low speech level can be understood and can disrupt.

“**The Bazaar**” is an analogy for the expectation that the area is not private, where sharing is the norm even though sound masking helps to ensure an acceptable level of speech privacy for work. Noise is far more acceptable to workers in the bazaar and a high level of intermittent background noise is expected. In fact, what workers overhear can lead to an improvement in their job competencies.

WHERE: Zoning and Designing Workplace Neighborhoods

Fig. 9 is a more detailed consideration of “the library” and “the bazaar” together with the kinds of tasks that might be further zoned to allow optimal effectiveness of the workforce by providing an environment that conforms to both the nature of the work and the worker’s expectation. As shown, a “bazaar” zone can have both highly interactive brainstorming functions or less interactive presentations and lectures. Given the variation in function, the zoning approaches will vary. Similarly, a “library” zone needs to support quiet work which can range from intense concentration to work that is more routine.

A good designer realizes that there are subcategories within the large framework that allow the space to be tailored to support the work.

Acoustical comfort is neither expensive nor difficult to achieve, provided that it is recognized as a key consideration at the planning and design stage of a project. Acoustic mitigation becomes much more expensive and difficult to retrofit after build out.

The first step is to identify the balance of interaction and concentration needed for a work group’s effectiveness. PBS has developed a survey methodology to facilitate workplace design that supports the nature of the work housed in the space. The PBS methodology is based on how mobile or “desk-bound” workers are, as well as how much workgroups either interact or need to concentrate. PBS’s Workplace Solutions Library (WSL) discusses how these “work patterns” form the basis of a rational approach to workplace design. The matrix on the next page (Fig. 10) illustrates the criteria for the 6 work patterns that result from this analysis.

FIG 9. A FINE-GRAIN LOOK AT LOCATING ACTIVITIES IN THE CONTEMPORARY OFFICE

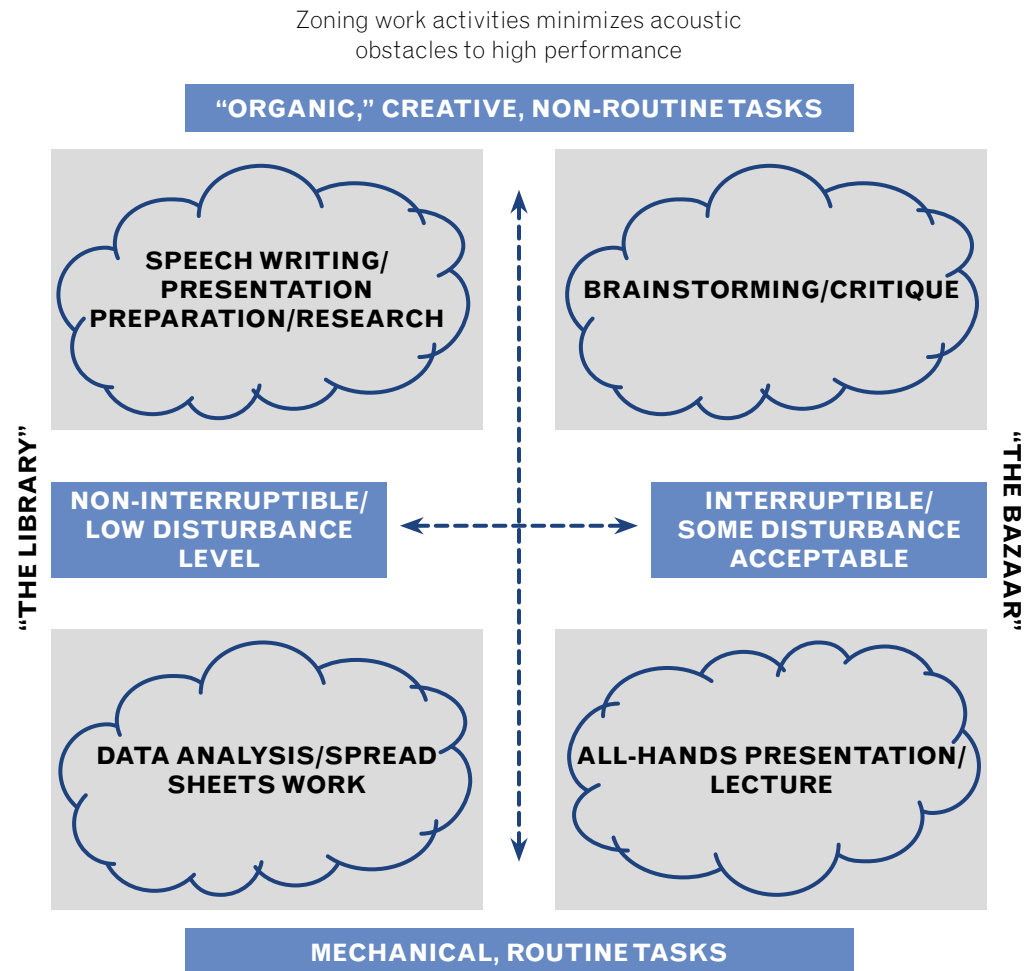

WHERE: Zoning and Designing Workplace Neighborhoods

FIG 10. GSA'S WORK PATTERN MATRIX

The work pattern matrix showing the six different types of knowledge. Interactive work (red) tends toward being more noisy than concentrative work (blue).

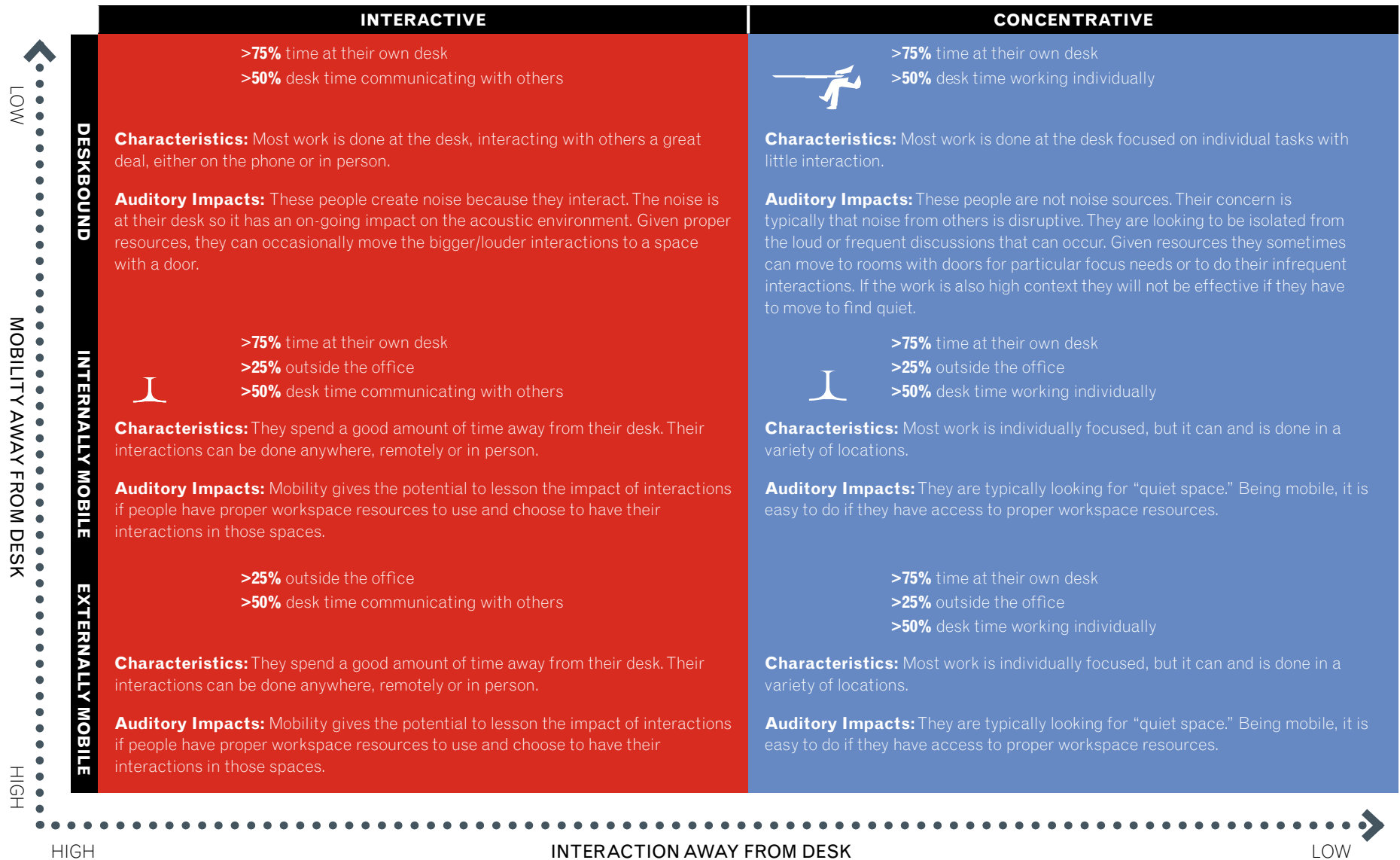

WHERE: Zoning and Designing Workplace Neighborhoods

FIG 13. SIX WORKPATTERNS LAYOUT ON ACTUAL FLOOR PLATE

The floor plan shows a hypothetical layout based upon a floor plate with all the work patterns in the WSL accommodated there. The various layouts and proximity to support areas are designed to fully support the six work patterns possible in the modern office.



- Internally-mobile Interactive
- Externally-mobile Interactive
- Desk-bound Interactive
- Internally-mobile Concentrative
- Externally-mobile Concentrative
- Desk-bound Concentrative

FIG 14. ZONE ORGANIZATION FOR ACOUSTIC OPTIMIZATION

When the work patterns are “filtered” through their potential to generate distractions, the importance of zoning becomes apparent to provide optimum support within the work environment. Red areas represent interactive and potentially noisier workplaces while blue areas indicate where heads-down work that would benefit from greater quiet is located.

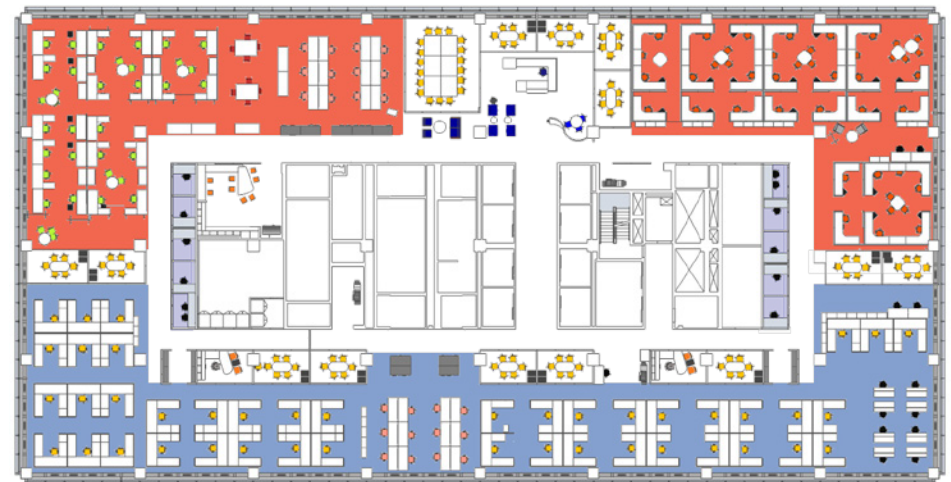

- Noisier Areas
- Quieter Areas

WHERE: Zoning and Designing Workplace Neighborhoods

NEIGHBORHOODS AND GROUP OWNERSHIP

Creating neighborhoods provides a number of acoustic advantages. First, it is easier to isolate sounds to a specific area if the neighborhood is properly sized. Other mitigation strategies – such as spatial separation – can be used to define neighborhoods. Second, neighborhoods make it easier to create a feeling of “ownership” that allows people some control over activities in their environment. The more a neighborhood is comprised of a single business group, the greater the ability to control activities and the acoustic environment. If residents are from unrelated groups, there generally will be less sense of ownership or control over the acoustic environment.

FIG 15. ACOUSTIC DESIGN AND ZONING DETAILS



DESK-BOUND INTERACTIVE

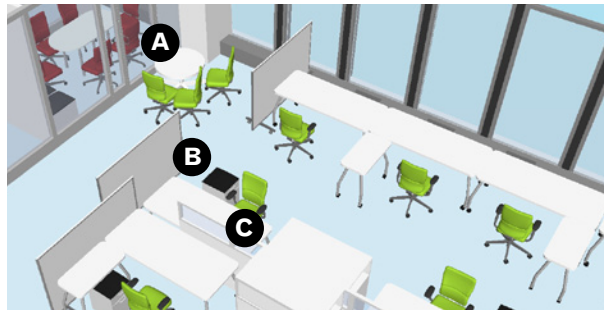

INTERNALLY-MOBILE INTERACTIVE

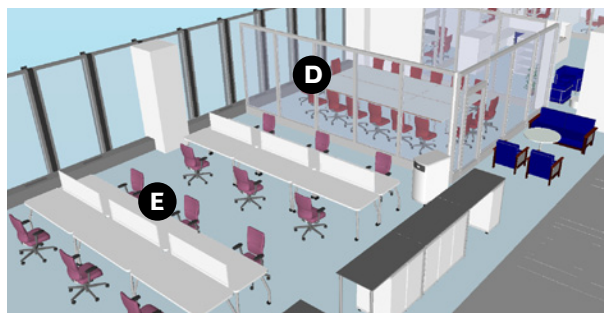

EXTERNALLY-MOBILE INTERACTIVE

- A** For the interactive deskbound groups, acoustic “clouds”, or baffles, over informal meeting areas should be considered for greater speech privacy.
- Higher panels give the illusion that the worker is “alone” and, as a result, voice level tends to rise. Interactive work patterns benefit from lower panels. A survey of 24,000 occupants by the Center for the Built Environment shows that in practice, there is virtually no difference in user satisfaction between low and high partitions.
- Shielding occupants from constant eye contact (seated privacy) will increase the ability to concentrate and will discourage disruptive idle chatter that is not related to the work. But higher than 51" is not recommended – low panels increase acoustic performance by making workers aware of others in the work space.
- Conference/focus rooms not only serve the necessary collaboration needs of the 21st century office, but also provide breaks between the interactive and adjacent, more quiet environments. Consider acoustic treatment on vertical surface per P-100.
- Provide an area near the interactive area for those times when a worker needs to do a more concentrative task. When a quiet area is to be shared with others, no phones are provided and even a sign indicating “quiet area” is a good practice. Panels to provide seated privacy may be included. (No higher than 51" recommended).

WHERE: Zoning and Designing Workplace Neighborhoods

FIG 16. ACOUSTIC DESIGN AND ZONING DETAILS

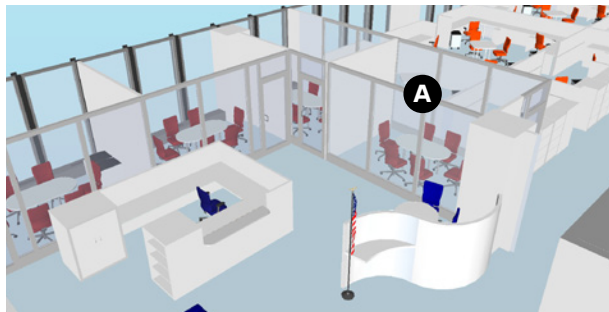

DESK-BOUND CONCENTRATIVE



INTERNALLY-MOBILE CONCENTRATIVE

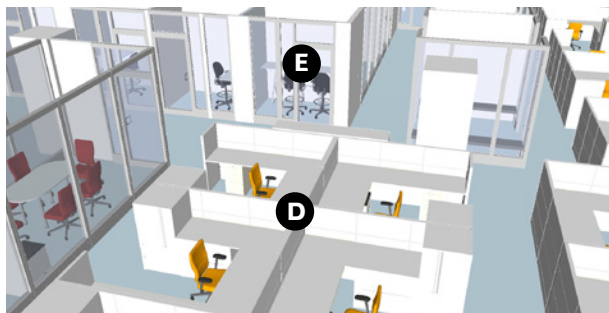

EXTERNALLY-MOBILE INTERACTIVE

- A** Other partitions for offices and conference rooms, STC 40-45. Acoustic treatment on vertical surfaces recommend to increase sound absorption. Attenuate open plenum return diffusers.
- B** High isolation: slab to slab (caulked at sill and head). The partition achieves a minimum of STC 53. This high level of isolation is more expensive than some other partitions, but may be necessary to allow for concentration. Personnel costs far exceed the cost of this mitigation! (Example justification: workplace next to child care or cafeteria).
- C** Minimum: sound absorption of enclosing workstation partition: 0.8 NRC
- D** Workstation, maximum 66" tall, with seated privacy recommended at 51" maximum. Use of glass panels above 51" strongly recommended (this will achieve 1 LEED interior point; possible additional points for even lower partitions, see LEED).
- E** Speaker phones in open areas not provided and should only be located in enclosed offices and conference rooms with STC 45 min enclosures. Locate entrances to conference rooms away from work areas, especially where large groups may be able to congregate before entering.

FIG 17. WORKSTATION ARRANGEMENT

The arrangement of workstations shown at the top illustrates the problem of laying out workstations so that occupants are speaking "at" each other. Positioning workstations as shown on the bottom will improve this acoustic challenge.

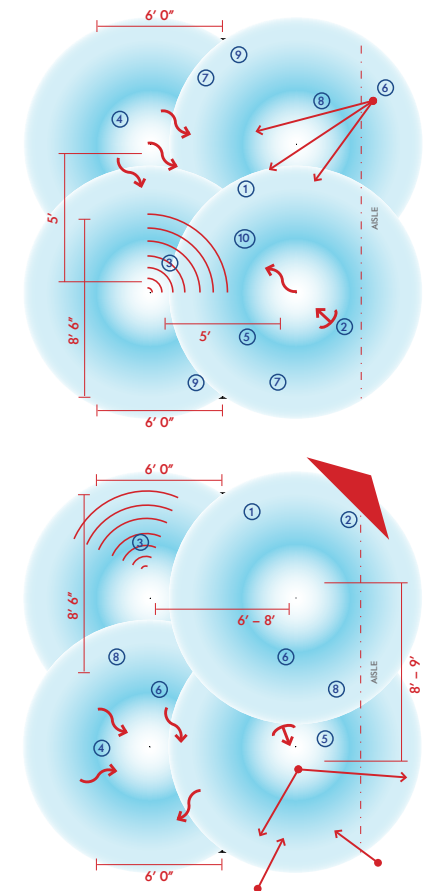

WHERE: Zoning and Designing Workplace Neighborhoods

LOCATION CHOICE / MOBILITY PROGRAMS

People now work in a variety of settings within the office or externally as their tasks and activities change. The more choices in settings at work, the easier it is to either move noisy activities away from others or for an employee to move to a quiet area. These behaviors require mobile technologies (e.g., wireless connectivity, mobile phones, laptops, phone headsets) to be successful. This mobility allows staff to avoid one of the greatest obstacles to workplace effectiveness: distraction arising from the use of conference calling from the workstation in an open office environment.



Another antidote to speaker phone conference calls in the open office: focus rooms.

Courtesy of DEGW



Alternative working areas away from a workstation can be used as needed and are characteristic of the new workplace. They allow employees to avoid distractions or keep them from distracting others.



Mobile Workers are not adding to the acoustical distractions in the office.

HOW: Technical Tips for Physical Acoustic Mitigation

Successful acoustic strategies rely on three techniques which can be applied in a wide variety of ways: **absorb sound, block sound transmission from one space to other spaces, and cover through sound masking.** At the basic level, acoustic treatments are relatively easy to understand and to apply. It is highly recommended that all three approaches are undertaken, however, if value engineering decisions are required, treat architectural first (absorb), mechanical second (block), and electronic third (cover). While the following treatments are minimum approaches for achieving acoustical comfort and speech privacy, resist bartering away acoustic mitigation during any subsequent “value engineering” for the good of the work and the employees. Make the decision in favor of excellent acoustics rather than, for example, a larger or “fancier” workstation. Remember, acoustics under-performance is the greatest source of user dissatisfaction.

ABSORB

Open workspaces require acoustical treatment on a significant portion of the surfaces in the space to absorb noise from people and equipment – floors, walls, window coverings, and ceilings can all be used to absorb sound. Specific solutions include acoustic ceiling tiles, carpeting, furniture finishes, curtains, and other ceiling treatments such as hanging “clouds” and acoustical plasters. The more absorptive the material added to the open space and the higher the acoustical performance rating of the material, the more acoustically comfortable the environment will be.

Two surfaces are key contributors to absorption: high quality acoustic ceiling material is typically the most significant contributor to sound absorption. Similarly, walls may be treated with acoustic material, either applied to a surface or integral with the wall finish. In addition, floors are an important source of absorption,

especially to dampen footfalls. For instance, carpet is especially effective at absorbing the irritating sound of footfalls, but cork and linoleum or other absorptive materials also work; whereas marble or ceramic tile will have the opposite effect.

BLOCK

Sound barriers are used to interrupt paths that carry sound from the noise source to the receiver. The simplest strategy is to put noise-generating sources inside a fully enclosed room designed to contain the sound – i.e. conference rooms. A reverse approach is “the inverse office” where noisy activities are in the open workspace and quiet areas are within the walled spaces. Walls can also be used between interactive and “heads-down” use areas without necessarily creating rooms. An example is a separation between open work areas and break areas or active circulation corridors. Mixing zoning strategies with acoustic treatments, sound “barriers” can be used more for absorption than as a barrier. An example is hanging panels designed to interrupt sound paths, but these more sophisticated solutions may require acoustic engineering expertise which is often beyond a small project’s means. Note that they must also be coordinated with sprinkler systems and may require Fire Marshal approval.

MYTH:

Plants in the office help control noise and provide speech privacy.

REALITY:

Not true. While plants provide many non-acoustical benefits, it would take a veritable jungle of plants to absorb much sound.

HOW: Technical Tips for Physical Acoustic Mitigation

The first principle of effective sound blocking is that *rigorously sticking to specified details in installation is key to success*. It is essential that field personnel verify that installation is per specification. Since sound operates like water, properly plugging holes is critical. This is why staggering electrical connections and gypsum board seams on either side of a partition and caulking partitions at the top and the bottom can make such a big difference in effective sound blocking. To understand how this works, a little terminology is important:

- The Sound Transmission Coefficient (STC), which is a number that most designers concentrate on when specifying partitions. It is the rating of a partition assembly tested in a laboratory. The category applies to tested gypsum partitions and to pre-manufactured demountables. However, when installed, clients may be very disappointed by performance. This is why specifying an insulation class (NIC) is important.
- NIC is a measured room-to-room noise reduction determined in accordance with testing agency procedures. It is not unusual for NIC to vary by ten points or more below the STC. Why? Improper installation and ineffective detailing can create a significant divergence between laboratory and actual performance. For instance, where a partition is installed directly over carpet, this may facilitate unwanted sound transmission.

Traditionally, blocking function has been the province of gypsum partitions in various configurations. However, with the need to make quick changes in the partitioning of spaces, and to do it in a way that lessens the impact on the nation's landfills, there is an increased use of reusable, reconfigurable, demountable partitions. These have some remarkable design features and can achieve fairly high sound transmission coefficients. However, they are typically a much higher first cost and so design rigor should limit their use to where they are truly needed.

REQUIRING TESTING OF INSTALLED PARTITIONS

Because all partitions are subject to sound leakage and other weaknesses noted above, it is recommended that as part of the installation contract, the installer be required to perform sound testing to make sure that the partition performs as specified and that any deficiencies be immediately corrected. Failing that, GSA should reserve the right to do such testing and require correction.

MYTH:

Addressing acoustical problems will interfere with access to daylight and other 'green design' goals.

REALITY:

Not true. You can proceed with every aspect of a low-energy 'green design' strategy—daylight, views, low partitions, raised floor, radiant ceiling—as long as you insist that speech privacy and acoustical comfort are serious issues that need to be dealt with. Planners, designers and engineers have a wide palette of sustainable acoustical products and solutions to choose from that can improve green outcomes. Furthermore, as of November 2010, you can earn LEED CI and LEED NC credit for setting and meeting acoustical requirements.



HOW: Technical Tips for Physical Acoustic Mitigation

COVER (MASK)

Most contemporary open workspaces are simply too quiet to be acoustically comfortable. Though this seems counter-intuitive, a low level of background noise allows interruptions to contrast with the quiet, causing a greater distraction than if the space had a higher level of background noise. To create the low-level of continuous and unobtrusive background sound that is essential for acoustical comfort and speech privacy, a “sound masking” system is required. There are many types of masking systems available, ranging from a tabletop fountain to complicated in-plenum electronic systems with multiple time of day settings. Minimize HVAC background (BG) and provide masking to make BG uniform. The US Access Board does not have any information on masking sound and how it affect access for the disabled both the hard of hearing and blind.

Some activities and spaces may require more or less sound masking than others. There are myriad ways to provide sound masking – to individuals, groups, or to large areas or with a single-function. Sound masking methods include ceiling based applications, desktop systems, or apps (downloads) for your mobile phone or laptop. “Personalized” sound masking at a specific workspace is also possible with new technologies. Given very specific acoustic needs at particular workspaces the options are available to create a focused “cone of silence” or to keep discussions from being understood nearby.

Because there are so many types of masking systems available, it is important to be specific about your requirements. For example, some work areas are well-suited for paging and music, while others are not.

All sound masking systems today can be tuned to respond to specific workspace acoustic situations (see the images in the topographic maps: Fig. 1 and Fig. 7, as an example of differing situations). Through the programming and design process, specific workspace areas that create different acoustic environments can be identified. Tuning the sound masking system allows for adjustment of these areas to create the best overall environment.

The chart on the following page (Fig. 18) shows how absorbing, blocking and covering (masking) can be achieved in closed versus open offices, depending on the level of confidentiality required.

HOW: Technical Tips for Physical Acoustic Mitigation

FIG 18: SUMMARY OF SOUND MITIGATION STRATEGIES



Receiver is at the mercy of the sender–

But when the sender can see the receiver (and interpret their body language) the sender will typically modulate their voices. In a 24,000 subject survey by the Center for the Built Environment (CBE), these were the most satisfied workers in terms of acoustic comfort. The CBE researchers hypothesized that greater voice modulation was the result of greater visibility of others in the environment.

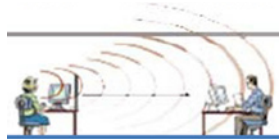

Absorb

Surfaces which absorb sound, particularly in the ceiling* diminish the strength of the sound from the sender as it travels across the path to the receiver. Walls and floors are also potential sound absorbers. With reflective floor finishes, such as marble, footfall can be especially annoying to workers.

*since it serves as a reflector

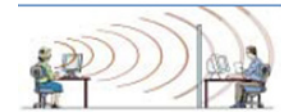

Block (inadequately)

This is the typical way that high workstation partitions are arranged and it illustrates why this arrangement is doubly ineffective: 1) Sound, being like water, leaks into the receivers' work area and 2) the sender cannot visually gauge the effect of their voice level on coworkers who are not in their line of sight.



Block

The strategy illustrated is very effective and very expensive. It requires that the ceiling be interrupted, requiring significant labor since the partition continues to the structure above the ceiling. Where the partition only stops at the ceiling which is typical commercial office construction, the blocking action is not nearly as effective because sound leaks are inevitable at the ceiling plane.

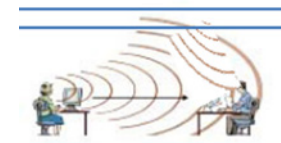

Cover (Mask)

Another important mitigation available for the open workplace is to supply additional sound, either through "white noise" or background noise such as mechanical equipment, which counteracts the typical quietness of a modern, open workspace. Masking helps to cancel the sound disturbance emanating from the sender.

HOW: Technical Tips for Physical Acoustic Mitigation

ACOUSTIC TREATMENTS FOR SPECIFIC ELEMENTS

“Clouds” – Occasionally, spaces have sound absorbent three dimensional “clouds” that hang from the ceiling. Designed properly in terms of shape, material and location, they provide additional sounds absorption within a space. Put in strategically targeted locations, they can be very effective in quieting naturally noisy activities.

“Flags” – Similar in style to the clouds, materials can be used that hang perpendicular to the ceiling to accomplish the same sound absorption. Traditionally these were often brightly colored materials that serve to liven up a space or carry wayfinding clues. Sound absorptive materials are available today that are translucent so that they do not block important light within the space.

Configuration – Configuration is an important tool that also addresses sound transmission paths. For ease of construction, space planners and designers tend to layout offices under the straight and rectangular theory. Adding elements that are not straight and rectangular can contribute to noise loss within a space. To be effective this approach needs to be a joint effort between the designer and the acoustic engineer.

Doors – Having doors on rooms is important for good acoustics. So is the design of the doors themselves.

Butt Hinge Doors – These have the potential to be very good with solid or insulated core. The undercut should be shielded in some fashion such as a sweep or drop seal gasket. Hollow core are only good to poor. The perimeter seal should be three sides and continuous closed cell foam. Results are poor if ‘buttons’ are used as impact stops or none at all.

“Barn” Doors – These can be very good if the door itself is solid core or insulated. The sloped upper track in combination with bottom seal and leading edge receiver box makes a very good door. However it is essential that operation is quiet and that there is proper gasketing.

Sliding Doors – Largely these are glass and do not have a high STC rating. Parallel top and bottom tracks do not seal as well as the barn door, which provide a good acoustic result.

Pivot Doors – Also generally glass with low STC rating. They have gaps on all four sides which makes them a poor choice for acoustical purposes.



Irregular, curved or angled walls can help mitigate unwanted sound reflections. This principle is useful for the design of conference rooms and walk up service windows. In these kinds of spaces, parallel reflective surfaces much more easily transmit sound to the opposite side of the room in a way that is distracting.

HOW: Technical Tips for Physical Acoustic Mitigation

FIG 19. CLOSED VERSUS OPEN OFFICE RECOMMENDED DETAILS

	WORKPLACE TYPOLOGY/ACOUSTICAL CLASSIFICATION				
	ENCLOSED			OPEN	
	Speech Security	Confidential	Normal	Quiet	Active
	Conversation in an adjacent space is inaudible	Conversation in an adjacent space is audible as muffled sound, but unintelligible	Conversation in an adjacent space is audible as garbled words – an eavesdropper could make out complete sentences	Workstation conversation is infrequent and is conducted in a low, "library" voice	Workstation conversation with one or more people frequently occurs in a normal speaking voice
	RECOMMENDED ACOUSTIC TREATMENT/DESIGN STRATEGY				
WALLS AND PARTITIONS	Gypsum partition slab to slab, caulked top and bottom Double stud if significant sound reinforcement is present NRC 0.95 material on 60% of walls	NIC 45 NRC 0.8 minimum on 25% of two adjacent walls	NIC 40 NRC 0.8 minimum on 25% of two adjacent walls	48" minimum (seated privacy) Absorptive material extends to head height and achieves NRC 0.8	None (bullpen), but nearby enclosing walls should have acoustic absorption of NRC 0.8
DOORS	Gasketed	Gasketed	Gasketed		
CEILING	Gypsum Board Ceiling 60% coverage with NRC 0.95 material	CAC 40 NRC 0.8	CAC 40 NRC 0.8	NRC 0.8 minimum	NRC 0.8 minimum
MECHANICAL NOISE	NC* 30 maximum to promote good intelligibility in space	NC 35 maximum	NC 35 maximum	n/a	n/a
SOUND MASKING	No	Not typical	Not typical	Yes	Yes
DESIGN CONSIDERATIONS	Accommodate full Audio Visual (A/V)			51" AFF maximum will achieve 1 LEED interior point (see LEED for possible additional points for even lower partitions)	Consider the use of benching** Provide "Phone Booth," small room for making private calls and using speakerphone.

*NC refers to background noise

**Benching is a furniture system that is a continuous work surface with few separating partitions and no traditional floor mounted partitions

HOW: Technical Tips for Physical Acoustic Mitigation

TYPICAL DRYWALL DETAILS TO ACHIEVE SOUND BLOCKING

STANDARD DETAILS

Specific additional details related to the three room types outlines in the guidelines are included below. The STC values shown below are per GSA document: "Facilities Standards for Public Service Buildings" (P-100) as follows:

Partition Type #1

NIC 40 (approximately STC 40)
between private offices, normal speech privacy

Partition Type #2

NIC 45 (approximately STC 45)
between private offices, confidential speech privacy

Partition Type #3

NIC 53 (approximately STC 53)
between teleconferencing rooms

OPEN WORKSPACE

The typically large areas of open workspaces assume that minimal or normal privacy is required.

- a. Sound absorbing materials on ceiling and all available wall surfaces including windows (e.g., curtains or sound-absorbing shades)
- b. Sound-shielding barriers (e.g., partitions, banners) as needed with a minimum absorptivity factor (NRC) of 0.8
- c. Floor-wide sound masking set at 45-48 dBA tuned to group zones
- d. Personal (desktop or computer-based) sound masking for a small percentage of individuals who may require it due to heightened sensitivity or local annoyance

HOW: Technical Tips for Physical Acoustic Mitigation

TYPICAL DRYWALL DETAILS TO ACHIEVE SOUND BLOCKING

NORMAL PRIVACY ROOM TREATMENTS

These rooms, typically offices, provide privacy, i.e., using normal voice level, conversation cannot be understood.

- Partition is full height, slab to slab, and sealed air tight all around, studs spaced 16-inches on center
- 3 5/8" metal channel studs
- 3-inch thick batts in stud cavity
- 1 layer of 5/8" thick gypsum board on each side; seal joints (see Partition Type 1)
- Sound absorbing panels on 25% of two adjacent walls with a minimum absorptivity factor (NRC) of 0.8 (per P-100)
- With 20 gauge studs, STC 40 (see Partition Type 1)

PRIVATE MEETING ROOM TREATMENTS

- Partition is full height, slab to slab, and sealed air tight all around, studs spaced 16-inches on center
- 3 5/8" metal channel studs
- 3-inch thick batts in stud cavity
- 2 layers of 5/8" thick gypsum board on each side
- Sound absorbing panels on 25% of two adjacent walls with a minimum absorptivity factor (NRC) of 0.8 (per P-100)
- With 20 gauge studs, STC 45 (see Partition Type 2)

CONFERENCE ROOM TREATMENTS (CONFIDENTIAL)

- Partition is full height, slab to slab, and sealed air tight all around, studs spaced 16-inches on center
- Double wall 3 5/8", 20 gauge metal channel studs
- Can be done as single wall with isolation with resilient channel on one side (see Partition Type 3)
- 3-inch thick batts in stud cavity
- 2 layers of 5/8" thick gypsum board on one side
- Sound absorbing panels on 25% of two adjacent walls with a minimum absorptivity factor (NRC) of 0.8 (per P-100)
- Minimum 50% of ceiling treated with minimum NRC 0.8 material
- Wall is rated STC 53 (see Partition Type 3)

PARTITION TYPE 1: SINGLE-SHEATHED SOUND-RATED PARTITION

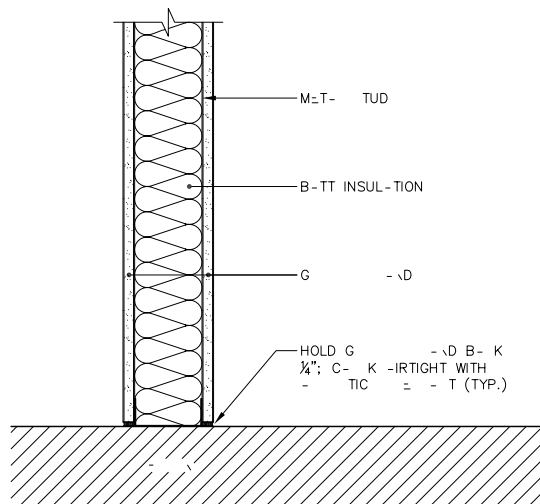

PARTITION TYPE 2: DOUBLE-SHEATHED SOUND-RATED PARTITION

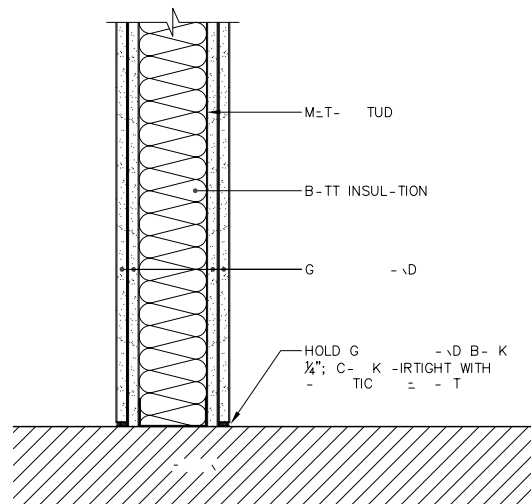

PARTITION TYPE 3: RESILIENTLY-ISOLATED WALL

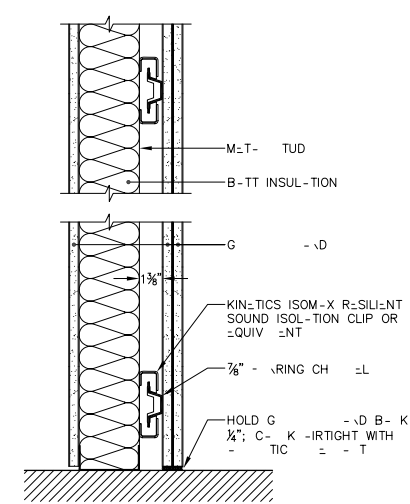

HOW: Technical Tips for Physical Acoustic Mitigation

FIG 20. DETAILING THE ACOUSTIC ENVIRONMENT

GSA P100 ACOUSTICAL REQUIREMENTS	
GENERAL TOPICS	1. Sound Isolation 2. Maximum Background Noise - Ventilation Systems - Electronic Sound Masking 3. Room Acoustics 4. Speech Privacy
01: OPEN PLAN WORKSPACE "NORMAL" SPEECH PRIVACY	Background Noise: NC 40 maximum Electronic Sound Masking: 45 to 48 dBA Provide absorption of NRC 0.9 minimum on 100% of ceiling Provide absorption of NRC 0.8 minimum on 25% of walls
02: PRIVATE OFFICES "NORMAL" SPEECH PRIVACY	Background Noise: NC 35 maximum Minimum Noise Reduction of Partitions: NIC 35 (with sound masking) NIC 40 (without sound masking) Electronic Sound Masking: 40 to 42 dBA Provide absorption of NRC 0.8 minimum on 25% of walls
03: PRIVATE OFFICES "CONFIDENTIAL" SPEECH PRIVACY	Background Noise: NC 30 maximum Noise Reduction of Partitions: NIC 45 minimum Provide absorption of NRC 0.8 minimum on 25% of walls
04: TELECONFERENCE FACILITY	Background Noise: NC 20 maximum Minimum Noise Isolation: NIC 53 Provide absorption of NRC 0.8 minimum on 50% of ceiling and 25% on two adjacent walls Optimum Reverberation Time: 0.5 seconds
05: MEETING ROOMS, TRAINING FACILITIES	Background Noise: NC 25 maximum Minimum Noise Isolation: NIC 48 Provide absorption of NRC 0.8 minimum on 50% of ceiling and 25% on two adjacent walls Optimum Reverberation Time: 0.6 seconds

SPECIAL CONDITIONS AND NEW ACOUSTICAL TREATMENTS

All materials used in surfaces and furnishings should address sustainability goals. For appropriate materials selections see the GSA Sustainable Facilities Tool (www.sftool.org). The tool is available to the public and is intended for use in small projects that do not normally involve a workplace consultant or designer.

While the old ways of solving noise and privacy problems may have been expensive, resource intensive, and required skilled professionals, many of the new materials and solutions are just the opposite. Be sure to ask your planning and design team to research green solutions like the following:

- Transparent or translucent glass or plastic partitions that are acoustically absorptive and use light-weight, 'green' insulation;
- Translucent, light weight, thin and acoustically absorptive surface materials;
- Light-weight, acoustically absorptive materials that can be used as design elements (clouds, banners, artwork, etc.) to enliven the workspace while contributing to acoustical comfort and privacy;
- New sound-absorbing or vibration-absorbing carpet and flooring material configurations that transform designers' thinking about 'green' flooring and associated maintenance issues;
- Low-voltage multi-function distributed audio (sound) systems that conserve energy and cut expense by integrating 'masking' (speech privacy) into normal, high-quality sound systems already required for paging and music;
- 'Personal privacy' (masking) products available for the desktop from drug stores, furniture companies or from online retailers;
- Even privacy apps you can download to a cell phone and play through ear buds!

ACOUSTICAL TREATMENTS IN HISTORIC BUILDINGS

Many federal agencies occupy historic buildings which pose particular acoustic problems due to the extensive use of hard reflective materials especially in the ceremonial spaces which typically adjoin work areas. These hard surfaces, such as marble and plaster, can be very hard to deal with since there is little possibility of absorption without change to the historic fabric. It is all the more important that adjacent work areas are well conceived in terms of sound absorption.

At the San Francisco U.S. Custom House, PBS worked with the Regional Historic Officer's approval to experiment with absorptive panels mounted on walls with clips in one room (see Image A), as well as stretched acoustic material at the ceiling (see Images B & C). To hear the difference in untreated versus treated rooms reference the Acoustic Materials Demonstration Video available via email request at workplace@GSA.gov.



BEFORE



AFTER: Stretched acoustic material applied to ceiling

TALK LIKE AN ACOUSTICIAN (or at least understand them)

A SHORT GLOSSARY

Ambient Sound (noise)

The background sound, including sounds from sources near and far, associated with a given work environment

Absorbing Materials

Materials that dissipate acoustic energy within their structure as heat and/or mechanical energy of vibration. Usually building materials designed specifically for the purpose of absorbing acoustic energy on the boundary surfaces of room or in the cavities of structures.

Acoustical Comfort

Term used by the U.S. Green Building Council LEED CI and NC to describe an interior work space where speech privacy and ambient sound levels meet the requirements in LEED Pilot Credit 24-Acoustics (November 2010).

Acoustical Environment

The overall environment, interior to exterior, that affects the acoustic conditions of the space or structure under consideration

Background Noise

The steady state underlying noise in a given environment.

Behavioral Protocols

A protocol is a code related to adherence to specific etiquette. In the workplace behavioral protocols are agreed on assumptions about how people will behave in the workspace. Acoustically they will relate to how and where people interact/talk.

Confidentiality

Confidential conversations are not at all intelligible to others.

Decibel (dB)

A basic metric for describing the magnitude of sound. A division of a uniform scale based upon 10 times the logarithm to the base 10 of the relative value being compared (sound intensity, pressure squared, or power) to a specified reference value

Decibel A weighting (dBA)

The filtering of sound that replicates the human hearing frequency response. The human ear is most sensitive to sound at mid frequencies (500 to 4,000 Hz) and is progressively less sensitive to sound at frequencies above and below this range. A weighted 1/3 Octave band sound level is the most commonly used descriptor to quantify the relative loudness of various types of sounds with similar or differing frequency characteristics.

Distraction

Diversion of attention.

Indoor Environmental Quality (IEQ)

Term used by the U.S. Green Building Council to describe the quality of the “indoor environment” in terms of air quality, lighting and access to natural light, thermal comfort, acoustical comfort and speech privacy

Inverse Office

The traditional planning approach to isolating the noise between group and individual workspaces is to put individual work in the open work area and group work behind doors (conference rooms). Where the central business focus is on group work, the group work is now being done in the open. When individual focus is needed, people move into a space designed to be quiet.

Loudness

The subjective response of the human hearing mechanism to changing sound pressure

Masking

The process by which sensitivity to a sound is decreased by the presence of another (masking) sound. Masking noise can be used to reduce the intelligibility or distraction of an intruding sound, such as speech.

Mobility Programs

Many work processes and resulting sets of work tasks are no longer tied to specific workspaces because of either technology or collateral material demands. Mobility programs create unassigned work environments that provide a wide array of workspace types to support a variety of group and individual work support needs. People then choose where they want to work based on what they need to accomplish at that given time.

Noise

Any undesired sound.

Noise Criteria Curves (NC, RC, NCB, etc.)

A numerical rating system or family of curves used to specify background sound levels over a specified frequency range. A set of spectral curves used to obtain a single number rating describing the “noisiness” of environments for a variety of uses. NC is typically used to rate the relative loudness of ventilation systems.

Noise Insulation Class (NIC)

A rating of the measured room-to-room noise reduction determined in accordance with the procedures of ASTM E336 and E413.

Noise Reduction (NR)

The reduction in level of unwanted sound by any of several means (e.g., by distance in outdoor space, by boundary surface absorption, by isolating barriers of enclosures, etc.

TALK LIKE AN ACOUSTICIAN (or at least understand them)

Noise Reduction Coefficient (NRC)

A single-number rating of the sound absorption of a material. It is the arithmetic average of the sound absorption coefficients of a sound-absorbing material at 250, 500, 1000, and 2000 Hz, rounded to the nearest 0.05.

Passive Attention

Involuntary awareness of external events or context, stimuli.

Privacy

Private conversations cannot be understood as a whole by others, even though an occasional word may be intelligible.

Reflection

The phenomenon by which a sound wave is re radiated ("bounced") from a surface.

Reverberation Time

The time (in seconds) required for the sound pressure level to decrease 60 dB in a room after a noise source is abruptly stopped. Reverberation time relates to a room's volume and sound absorption.

Sound Absorption

The property of absorbing sound energy possessed by objects and surfaces, including air.

Sound Masking

Use of an electronic sound system to deliver a minimum level of low-level, unobtrusive background sound through speakers that is matched to the spectrum of human speech so that normal conversation is rendered unintelligible by casual listeners. Sound masking is often a feature included in sound systems used to deliver paging and/or music.

Sound Transmission Class (STC)

Barrier performance of materials used in general building construction (walls, ceilings, and floors); usually applies to the separation between two adjoining spaces. A single-number rating derived from laboratory measurement of found transmission loss. STC is calculated in accordance with ASTM E413, "Classification for Rating Sound Insulation." The STC describes the sound-insulating properties in the 100-4 kHz frequency range, primarily for assessing speech transmission through a structure, such as a partition.

VOIP Phone Systems

VOIP (Voice Over Internet Protocol) are phone systems designed to work over data networks and so do not require hard wired phone to phone connections like traditional phone systems. Skype is a popular example of one.

GSA P-100 ACOUSTICAL REQUIREMENTS

General Topics

- Sound Isolation
- Maximum Background Noise, Ventilation systems and Electronic sound masking
- Room Acoustics
- Speech privacy

#1 Open Plan workspace

"Normal" Speech Privacy

- Background Noise: NC 40 Maximum
- Electronic Sound Masking: 45 to 48 dBA
- Provide absorption of NRC 0.9 Minimum on 100% of ceiling
- Provide absorption of NRC 0.8 minimum on 25% of walls

#2 Private Offices

"Normal" Speech Privacy

- Background Noise: NC 35 Maximum
- Minimum Noise Reduction of Partitions: NIC 35 Minimum (with sound masking) and NIC 40 Minimum (without sound masking)
- Electronic Sound Masking 40 to 42 dBA
- Provide absorption of NRC 0.8 minimum on 25% of walls

#3 Private Offices

"Confidential" Speech Privacy

- Background Noise: NC 30 Maximum
- Noise Reduction of Partitions: NIC 45 Minimum
- Provide absorption of NRC 0.8 minimum on 25% of walls

PUTTING IT ALL TOGETHER: Costs

FIG 21: COSTS

The reader should bear in mind that these costs have been prepared by a professional cost estimator in July, 2011. The costs are based on specific products typical of the class. These costs will vary. What is most important to take from the chart at right is the relative comparison of costs to each other so that decision-makers can judge the cost of acoustic mitigation. Remember that personnel costs dwarf these figures and acoustic comfort is key to getting the best out of employees in the workplace!

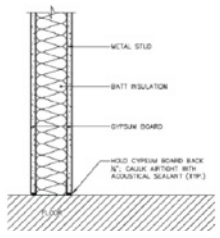
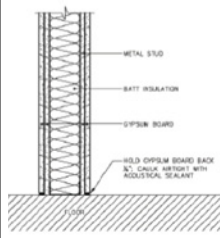
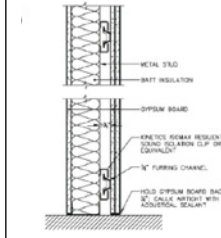
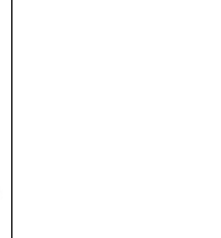
CONSTRUCTION								
	Baseline Partition	Partition Type #1	Partition Type #2	Partition Type #3	Sound absorbing wall panel	Lay-in acoustical tile ceiling in 2x4 grid	Lay-in acoustical tile ceiling in 2x4 grid	Sound masking system
DESCRIPTION	<p>12' high 20 gauge studs slab to slab, 24" o/c, 5/8" gypsum board each side, Level 4 finish, painted.</p> <p>Baseline partition is not sound rated.</p>	<p>Same as Baseline Partition plus R-11 fiberglass insulation, in stud cavity. Wall penetrations and perimeter sealed with acoustical caulking. Low voltage devices placed in outlet boxes. All electrical outlets sealed with outlet box pads.</p> <p>STC 40</p>	<p>Same as Partition Type #1 plus one layer of 5/8" gypsum board added on each side.</p> <p>STC 45</p>	<p>Same as Partition Type #2 except only one layer of gypsum board on one side and 1 3/8" resilient channels isolating gypsum board on the other side.</p> <p>STC 53</p>	NRC 0.8 minimum	<p>Celotex BET-197 NRC 0.55</p>	<p>Capaul Nubby NRC 0.9</p>	Logison
COST	<p>\$154.30/lineal foot \$12.86/sq. ft.</p>	<p>15% more than Baseline Partition \$176.69/lineal foot \$14.73/sq. ft.</p>	<p>31% more than Partition Type #1 50% more than Baseline Partition \$231.66/lineal foot \$19.30/sq. ft.</p>	<p>3% less than Partition Type #2 45% more than Baseline Partition \$224.56/lineal foot \$18.71/sq. ft.</p>	\$22.30/sq.ft. installed	<p>\$5.42/sq. ft. Installation of grid and tile, not including lights, sprinklers, etc.</p>	<p>\$6.97/sq. ft. 28% more than standard acoustical tile ceiling</p>	<p>\$1.81 per sq. ft. installed</p>

Refer to page 35 for full-scale versions of the details shown as thumbnails above. STC ratings shown here are derived from Canadian Sheet Steel Building Insititute Reference Report IRC-IR-761 and Veneklasen Associates testing at Western Electro Acoustics Laboratory.

REFERENCES

RESEARCH RESOURCES

Acoustical Society of America, www.asa.aip.org

Beranek, L.L. *Noise Reduction*. New York: Wiley, 1960.

Cavanaugh, W.J., G.C. Tocci, J.A. Wilkes. *Architectural Acoustics: Principles and Practice*. 2nd ed. New York: Wiley, 2009.

Canadian Sheet Steel Building Institute. Reference Report IRC- IR-761 and Veneklasen Associates testing at the Western Electro Acoustic Laboratory

Egan, M.D., *Architectural Acoustics*. Fort Lauderdale: J. Ross Publishing, 2007; originally New York: McGraw Hill 1988.

GSA PBS P-100 Acoustic Standards

Heerwagen, J., K. Kampschroer, K. Powell and V. Loftness. "Collaborative Knowledge Work Environments". *Building Research and Information* Nov-Dec 32(6) (2004): 510-528.

Heerwagen, J., K. Kelly, K. Kampschroer and K. Powell. "The Cognitive Workplace". *Creating the Productive Workplace*. Ed. D. Clements-Croome. London: Taylor & Francis, 2006.

Institute of Noise Control Engineering of the USA, www.inceusa.org

Jensen, K.L., E. Arens and L. Zagreus. "Acoustical Quality In Office Workstations as Assessed by Occupancy Surveys". *Proceedings of Indoor Air*, 2005.

Johnson, Steve, quoted in the Colorado Real Estate Journal, August 6-9, 2008. Used with permission of the author.

Rashid, M., K. Kampschroer, J. Wineman and C. Zimring. "Spatial layout and face to face interaction in the office." *Environment and Planning B: Planning and Design* 33(6) (, 2006): 825-844.

Zijlstra, F.R.H., R.A. Roe, A.B. Leonara, and I. Krediet. "Temporal factors in Mental Work: Effects of Interrupted Activities". *Journal of Occupational and Organizational Psychology* 72 (1999):163-185.



**U.S. GENERAL SERVICES ADMINISTRATION
PUBLIC BUILDINGS SERVICE
1800 F STREET, NW
WASHINGTON, DC 20405**

WWW.GSA.GOV

ACKNOWLEDGEMENTS

The Center for Workplace Strategy would like to particularly acknowledge the editing assistance of Judi Heerwagen and Michael Bloom of GSA's Federal High Performance Green Building, as well as David Sykes and Bill Cavanaugh for their "above and beyond" help in editing this document. In addition, the core team of Charles Salter (Charles Salter Associates) and Paul Heath and Clark Sept of Business Place Strategies. Thanks also to the Gensler team for the acoustic diagrams and help with the final design.

GSA

Michael Bloom
Patricia Cheng
Judith Heerwagen
Diane Juba
Kevin Kelly
Kevin Powell

Business Place Strategies

Paul Heath
Clark Sept

Charles M. Salter Assoc.

Charles Salter

Gensler

Gervais Tompkin

Haworth

Jay Brand

Place Coach

Sally Augustin

IA Interior Architects

R. J. Brennan

IDEO

Beau Trincia

Arup

Nick Antonio

BRC Acoustics

Dan Bruck

Acoustics Research Council

David Sykes

Armstrong

Ken Roy

US Social Security Administration

Donna A. Ellis

US State Department

Thierry Rosenheck

US Coast Guard

Leo Lozano