

The effect of cold exposure on the levels of glucocorticoids, 11-hydroxysteroid dehydrogenase 2, and placental vascularization in a rat model

Q.-J. ZHANG¹, S.-W. CHEN², X. XU¹, H.-L. ZHANG¹, J.-Y. YAN¹

¹Fujian Maternity and Child Health Hospital, College of Clinical Medicine for Obstetrics & Gynecology and Pediatrics, Fujian Medical University, Fuzhou, Fujian Province, China

²Department of Obstetrics & Gynecology, The Second People's Hospital Affiliated to Fujian University of Traditional Chinese Medicine, Fuzhou, Fujian Province, China

Abstract. – OBJECTIVE: Cold exposure (CE) before birth is one of the initial stressors that may impact mammalian pregnancy, changing placental and fetal development and affecting the health of the offspring. While glucocorticoids (GCs) participate in the body's response to the stress of CE, the specific mechanisms of their action are unclear. This study aims to determine the effect of CE stress on the placenta and to test whether stress, caused by cold exposure in pregnancy impairs fetal development by changing placental angiogenesis via excessive GC expression.

MATERIALS AND METHODS: CE rat model was created by exposing 30 SD rats to cold pre-conception, or during the first, second, and third weeks of pregnancy. Serum cortisol and soluble fms-like tyrosine kinase-1 (sFlt-1) expression levels, physiological index changes (food intake, body weight change and blood pressure), and pregnancy outcomes (fetal rat weight, number of live fetal rats, and placental weight) were collected at baseline and at different time points after the conception. Protein expression levels of 11 β -hydroxysteroid dehydrogenase 2 (11 β -HSD2), glucocorticoid receptor, vascular endothelial growth factor A (VEGF-A), placental growth factor (PlGF), and sFlt-1 in placental tissues were measured by western blotting. Cytokeratin (CK) and laminin (LN) in trophoblasts, and α -actin in vascular smooth muscle of the spiral arteries of pregnant rats after the systemic cold treatment were assessed by immunofluorescence and visualized by fluorescent microscopy. To test the effect of 11 β -HSD2 levels on the placental recasting, human first-trimester extravillous trophoblast cells (HTR8/SVneo) underwent knock-down using specific 11 β -HSD2 siRNA constructs. Expression levels of 11 β -HSD2 were analyzed by quantitative real-time PCR (qPCR) and into HTR8 cells, and the expression levels of the *11 β -HSD2* gene in each group were measured using qPCR. Cell migration and invasion was assessed by Transwell migration assay, and sFlt-1 levels in HTR8 cells were measured by ELISA.

RESULTS: CE pre-conception led to consistently increasing serum corticosterone and sFlt-1 levels throughout pregnancy, and persistently increased diastolic blood pressure (DBP) in rat CE model compared to control animals. CE during the second week of gestation (Gp.3) was associated with significantly lower placental weight ($p=0.0003$). Cold exposure in the third week (Gp.4) was associated with significantly ($p=0.001$) lower fetal weight. CE pre-conception was associated with significantly decreased placental levels of 11 β -HSD2, glucocorticoid receptor, VEGF-A, PlGF, and sFlt-1 proteins and α -actin compared to the control group. Silencing 11 β -HSD2 by siRNA led to reduced cell migrations and invasion, and markedly increased expression levels of sFlt-1 in HTR8/SVneo cells ($p<0.05$).

CONCLUSIONS: Pre-conception cold exposure and during early pregnancy leads to increased GCs levels and impaired placental 11 β -HSD2 activity. We suggest that the subsequent 11 β -HSD2-induced increase in the sFlt-1 expression during early pregnancy may affect placental vascular remodeling and change placental morphological structure and function.

Key Words:

Glucocorticoids, Developmental Origins of Health and Disease (DOHaD), Prenatal stress, Placenta-mediated pregnancy complication (PMPC), 11 β -hydroxysteroid dehydrogenase 2 (11 β -HSD2).

Introduction

Exposure to certain environmental factors during critical periods of development can affect the long-term health of the offspring¹. Numerous studies²⁻⁴ focused on the relationship between poor intrauterine environment and long-term adverse cardiovascular, metabolic, endocrine, and

neurological outcomes in offspring, and the critical role played by stress-induced changes in the shape and function of the placenta.

Glucocorticoids (GCs) are a class of lipophilic steroid hormones that are regulated by the hypothalamic-pituitary-adrenal axis (HPA) and can rise sharply in stress conditions. In most mammals, the concentration of fetal plasma GCs can show a physiological exponential rise close to the time of delivery and can bind to intracytoplasmic receptors to form a complex in the nucleus^{5,6}. GCs play an important regulatory role in the development, growth, metabolism and immune function of the body^{7,8}. Studies^{9,10} show that the physiological surge of GCs that occurs near delivery is critical for the spontaneous adaptive adjustment of the fetus from the intrauterine environment to the external environment. Clinically, for pregnant mothers with a threatened preterm birth before 35 weeks of gestation, the use of dexamethasone or betamethasone can promote fetal maturation, giving neonatologists valuable treatment opportunities to improve the prognosis of premature infants significantly. Moreover, late-pregnancy hypercortisolemia is associated with lower incidence of postpartum depression and stress¹¹. Over the past 40 years, prenatal and postnatal GCs treatment has significantly reduced morbidity and mortality in preterm infants and is one of the best examples of basic experimental clinical translation-guided clinical practice.

Although GCs play an important role in the fetal transition of newborns, early exposure to high levels of GCs during pregnancy may have a lasting negative impact on the development and function of various fetal organs, leading to altered physiological functions and, in some cases, pathology¹². 11 β -hydroxysteroid dehydrogenase 2 (11 β -HSD2) is an enzyme that degrades endogenous GCs. Some studies^{13,14} have found that 11 β -HSD2 is abundantly expressed on the fetal surface of the placenta and in the fetal brain, forming a barrier that converts biologically active GCs into 17-hydroxy-11-dehydrocorticosterone and inactivates it. Due to this degradation by the placental 11 β -HSD2 barrier, the levels of GCs that normally reach the fetus are only 3-10% of the total GCs in the maternal circulation¹⁵ (**Supplementary Figure 1**). Previous studies¹⁶ have shown that pregnancy complications associated with placental perfusion disorders, such as pre-eclampsia (PE) and fetal growth restriction (FGR), are associated with reduced levels of placental 11 β -HSD2. Recent animal model and human

studies¹⁷ explored the connection between maternal stress and the levels of 11 β -HSD2 and showed that maternal stress itself may affect the expression of this enzyme as a protective measure for the fetus. Moreover, maternal physiological stress during pregnancy is associated with lower placental 11 β -HSD2 expression, leading to increased cortisol reactivity in the offspring¹⁸. We aimed to test whether the stress of cold exposure before and during early pregnancy may cause fetal overexposure to active GCs by stimulating maternal GCs and downregulating the expression of 11 β -HSD2 protein in placental trophoblasts, changing their invasion capacity and affecting the expression of placental vascular factors.

Materials and Methods

Animal Models and Ethics

Fifty-four 6-week-old SPF-grade SD rats were used in this study. For establishing the cold exposure model, 30 rats (20 female rats and 10 male rats), provided by the Hangzhou Medical College, license number: SCXK (Zhejiang) 2019-0002, underwent two weeks of adaptive feeding, and then allocated according to the random number table method. Rats were divided into 5 groups (Gp.1-5), 6 animals in each group (4 females and 2 males) with a female to male ratio of 2:1. Gp.1: cold exposure (CE) preconception; Gp.2: CE during the first week of pregnancy; Gp.3: CE during the second week of pregnancy; Gp.4: CE during the third week of pregnancy; Gp.5: control (no CE). Microscopic analysis of the female vaginal smear confirmed the presence of sperm and was set as gestational day (GD) 0. As shown in Figure 1, according to different groups, rats lived for one week in an artificial climate box set to 8°C cold exposure during different periods before and after the conception. Animals in Gp.5 were used as the control group, with no cold exposure throughout the gestational cycle. Changes in physiological indicators throughout pregnancy were observed in different groups, from GD 0 to day 19.5. Food intake of females was observed every two days and blood pressure (BP) measurements were performed on all rats by a noninvasive tail sleeve system. Serum cortisol and soluble fms-like tyrosine kinase-1 (sFlt-1) expression levels, physiological index changes (food intake, body weight change and blood pressure), and pregnancy outcomes (fetal rat weight, number of live fetal rats, and placental weight) were collected in pregnant rats in

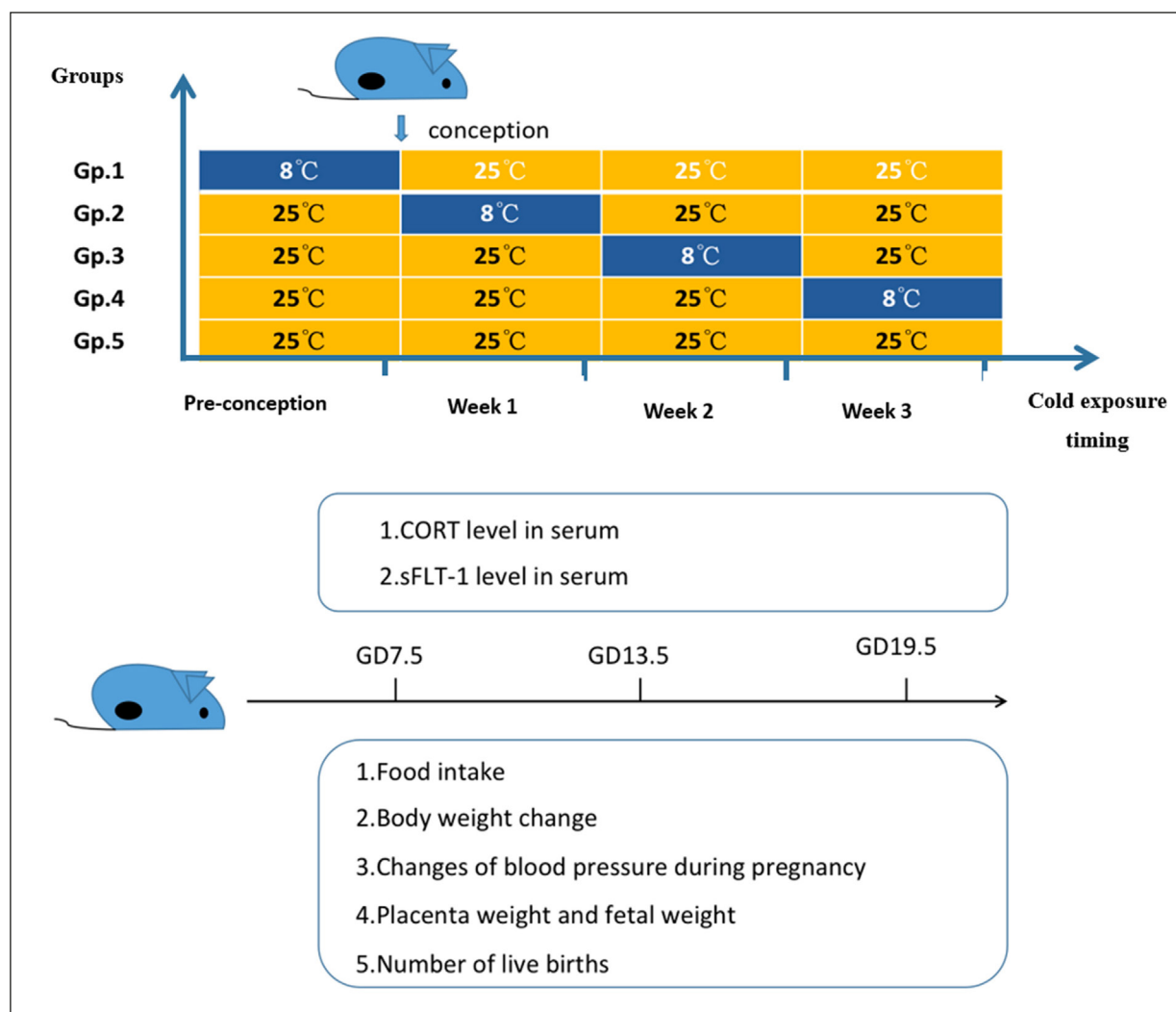

Figure 1. Rats were grouped according to different timing of cold exposure (8°C). Gp.1: cold exposure before conception, Gp.2: cold exposure in the first week after conception, Gp.3: cold exposure in 2nd-week post-conception, Gp.4: cold exposure in 3rd-week post-conception, and Gp.5: control group without cold exposure. The first day of the vaginal plug was defined as GD0 (gestation day). Serum cortisol and sFlt-1 expression levels, physiological index changes (food intake, body weight change and blood pressure) and pregnancy outcomes (fetal rat weight, number of live fetal rats and placental weight) were collected in pregnant rats in first (GD 7.5), second (GD 13.5) and third (GD 19.5) week after the conception.

the first (GD 7.5), second (GD 13.5) and third (GD 19.5) week after the conception.

Animals were then sacrificed with deep anesthesia, and the weight of each placenta and newborn was measured.

In further experiments, twenty-four rats (16 females and 8 males) were divided into 4 groups according to the random number table method, with a female-to-male ratio of 2:1, 4 female rats per group (Figure 2). Rats of different sexes were grouped according to whether they lived in an artificial climate chamber at 8°C, 1 week before conception. At 7.5 days post-conception, animals

were then sacrificed with deep anesthesia, and the placentas of female rats were taken.

All animal procedures were carried out in accordance with the guidelines for the use of laboratory animals published by the People's Republic of China Ministry of Health (January 25, 1998) with the approval of the Ethics Committee of the Fujian Provincial Maternity and Children's Hospital (2021KD).

Blood Pressure Measurement

The pulse pressure sleeve of the sphygmomanometer was placed on the proximal end of the

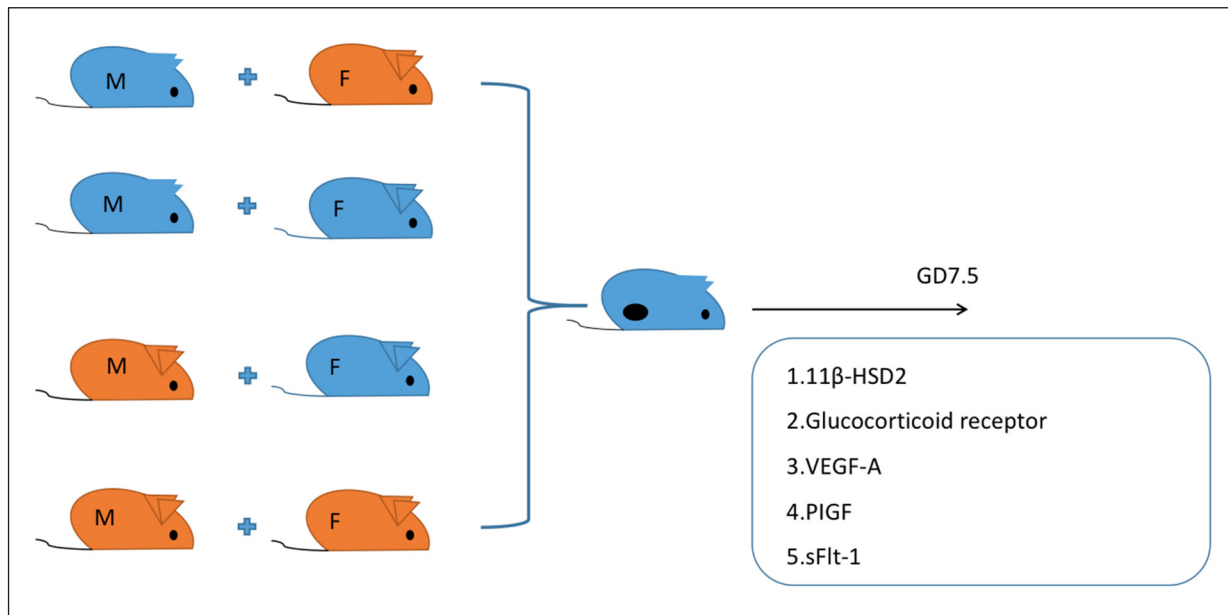

Figure 2. Rats were grouped based on the pre-conception exposure to cold. The blue color of the animal in the picture indicates that it lived in an artificial climate chamber at 8°C one week before conception. A female-to-male ratio was 2:1, with 4 female rats per group. The first day of the vaginal plug was defined as gestation day (GD) 0. Placenta detection indicators of pregnant rats were taken at GD7.5.

rat's tail, the high-sensitivity pulse transducer was placed in the upper third of the tail, and the surface of the transducer was aligned with the ventral side of the tail and fixed with a nylon buckle. After acclimatizing the animal, the sensitivity of the amplifier was adjusted to make the pulse wave large enough, and an inflatable balloon was used to increase the pressure in the pressure sleeve until the pulse wave completely disappeared. Pressure in the pressure sleeve was then slowly reduced. The height of the pressure curve corresponding to the first wave peak indicated the systolic blood pressure (BP) of the animal. The secondary wave peak indicated diastolic BP.

Immunofluorescence Analysis

On GD 20.5, rat placentas were retrieved from dams. The tissues were then fixed overnight at 4°C in 10% buffered formalin. Tissues that had been processed were embedded in paraffin. Each uteroplacental unit had serial pieces (5 m) cut out of it. The dehydrated placenta samples were paraffin-embedded and cooled at room temperature. Paraffin sections (5 μm) were prepared, dewaxed, and incubated in sodium citrate buffer (pH 6.0) for 10 min, boiled for 30 minutes and then cooled naturally at room temperature for antigen retrieval. After blocking in 3% H₂O₂, the slides were incubated overnight at 4°C with cytokeratin

(CK) (1:200; Bioss, bs-10739R) and anti-laminin antibody (LN) (1:200; Bioss, bs-0821R) and anti-α-actin antibody (1:200; Proteintech, 23660-1-AP). After three washes with phosphate buffered saline (PBS), the slides were incubated with Coralite 488-conjugated Affinipure goat anti-rabbit IgG (H+L) (1:1,000; Proteintech, SA00013-2) for 1 h at room temperature, protected from light, mounted and observed under a fluorescence inverted microscope (NIKON, Japan, Ts2-FL).

Western Blot Analysis

Placental tissue from each group was ground in a 1.5 mL centrifuge tube, lysed by shock lysis in the Radio-Immunoprecipitation Assay (RIPA) (Meilun Biotechnology, Dalian, China, MA0151), and the protein concentration was determined using the Bicinchoninic acid (BCA) protein assay (Thermo Fisher Scientific, Waltham, MA, USA). Proteins were then separated by SDS-PAGE (Meilun Biotechnology, MA0382), transferred to the nitrocellulose membrane (Merck, HATF0010), and blocked in a 5% BSA blocking solution for 1 hour. Membranes were incubated with the corresponding primary antibody overnight at 4°C, with agitation, followed by 1 h incubation with the horse radish peroxidase (HRP)-conjugated secondary antibody in the dark. Proteins were visualized using an enhanced chemilumines-

cence (ECL) kit (Pierce Chemical, USA). Image J software (National Institutes of Health, Bethesda, MA, USA) was used for image analysis, and Prism (GraphPad Software, San Diego, CA, USA) was used for statistics.

All the following antibodies were purchased from Proteintech (Chicago, IL, USA) 11 β -HSD2 (1:2000, Proteintech, 14192-1-AP) and Glucocorticoid receptor (1:4000, Proteintech, 24050-1-AP). vascular endothelial growth factor (VEGF)-A (1:2000, Proteintech, 19003-1-AP), Placental growth factor (PIGF) (1:1500, Proteintech, 10642-1-AP), sFlt-1 (1:1500, Proteintech, 13687-1-AP), Glyceraldehyde-3-phosphate dehydrogenase (GAPDH) (1:10000, Proteintech, 60004-I-Ig). Secondary antibodies were labeled with horseradish peroxidase goat anti-mouse IgG (1:8000, SA00001-1, Proteintech) and goat anti-rabbit IgG (1:8000, SA00001-2, Proteintech).

Trophoblast Migration, Invasion Assessment

Human first-trimester extravillous trophoblast cells (HTR8/SVneo) cells, an extravillous cytotrophoblasts (EVT) cell line, was received as a gift from Prof. Charles H. Graham (Queen's University, Canada). Cells were cultured in Dulbecco's Modified Eagle Medium (DMEM) high-glucose complete medium supplemented with 10% fetal bovine serum (FBS), 100 U/mL penicillin, 100 μ g/mL streptomycin, all purchased from Thermo Fisher Scientific, Waltham, MA, USA) at 37°C, 5% CO₂, saturated humidity. The migration properties of cells were examined using a 24-well migration chamber (Corning, NY, USA) according to the manufacturer's instructions. Briefly,

cells were seeded into the top chamber and allowed to migrate to the bottom chamber containing cortisol-supplemented medium (1 nm). After 24 h of incubation, cells that moved to the underside of the membrane were stained with DAPI (Beyotime Biotechnology, Shanghai, China). The number of cells on the membrane was counted at \times 200 magnification and averaged from three random microscopic fields.

Invasive properties were assessed by the ability of cells to digest and invade the Matrigel-coated 8- μ m-pore size polycarbonate membrane Transwell insert (Corning-Costar, Corning, NY, USA). Briefly, HTR8 cells were seeded onto the insert and treated with corticosterone (1 nm) for 24 hours. A cotton swab was used to scrape off the non-invasive cells on top of the filter, and the cells were collected and stored at -80°C and stained with DAPI for microscopic analysis. Invading cells were quantified at \times 200 magnification from three random fields under the microscope.

RNA Interferences

The siRNAs for 11 β -HSD2 were designed for and synthesized by AnburuiBD (Fuzhou, China). Control siRNA was a scrambled sequence without any specific target (Table I).

HTR8/SVneo cells were plated on 24-well plates and cultured for 48 h. Cells were then transfected with 5uLsiRNA using Lipofectamine[®] 3000 Transfection Kit (Invitrogen, Waltham, MA, USA) following the manufacturer's instructions. After 48-72 h, cells were harvested, and the efficiency of RNA interference was determined by western blotting using 11 β -HSD2 antibody (1:2000, Proteintech, 14192-1-AP).

Table I. Sequence of siRNA constructs.

siRNA Name	Sequence (5' to 3')	Length	Modification
HSD11B2 (human) siRNA-925	AGACAGAGUCAGUGAGAAATT	21	RNA
	UUUCUCACUGACUCUGUCUTT	21	RNA
HSD11B2 (human) siRNA- 545	GACCAAACCAGGAGACAUUTT	21	RNA
	AAUGUCUCCUGGUUUGGUUCTT	21	RNA
HSD11B2 (human) siRNA-412	GCAAGGAGACGGCCAAGAATT	21	RNA
	UUCUUGGCCGUCUCCUUGCTT	21	RNA
Negative control (NC)	UUCUCCGAACGUGUCACGUTT	21	RNA
	ACGUGACACGUUCGGAGAATT	21	RNA
FAM Negative control (NC)	UUCUCCGAACGUGUCACGUTT	21	5'6-FAM, RNA
	ACGUGACACGUUCGGAGAATT	21	RNA
(human GAPDH)	GUAUGACAACAGCCUCAAGTT	21	RNA
	CUUGAGGCUGUUGUCAUACTT	21	RNA

Glyceraldehyde-3-phosphate dehydrogenase (GAPDH).

Quantitative Real-Time-PCR

Expression of 11 β -HSD2 was analyzed by quantitative real-time PCR (qPCR). Briefly, total RNA was isolated from the cells using 1 mL RNAiso Plus (TaKaRa, 9019, Kusatsu, Japan) according to the manufacturer's instructions. One microgram of total RNA was reverse transcribed in a volume of 20 μ l with the NovoScript[®] Plus 1st Strand cDNA Synthesis SuperMix (Novoprotein, Beijing, China, E047-01B). GAPDH expression was used as a control.

The primers used are as follows:

GAPDH Forward: 5'-GGTGTGAACCAT-GAGAAGTATGA-3'; Reverse: 5'-GAGTCCTTC-CACGATACCAAAG-3'.

11 β -HSD2 Forward: 5'-GTCAGTGG-GAAAAGCGCAAG-3'; Reverse: 5'-CTA-CAACTGGGGTGAGGTCG-3'.

The temperature range to detect the melting temperature of the PCR product was set from 60°C to 95°C. The specificity of PCR products was examined by melting curve at the end of the amplification and subsequent sequencing. To determine the relative quantitation of gene expression for both 11 β -HSD2 and GAPDH genes, the comparative Ct (threshold cycle) method with arithmetic formulae ($2^{-\Delta\Delta Ct}$) was used.

Matrigel Assay

Cells were plated onto the Matrigel-coated 8- μ m-pore size polycarbonate membrane Transwell inserts and transfected with the appropriate siRNA constructs as described above. When the density of cells transfected with siRNA reached 60%, cells were treated with 1 nm cortisol for 24 h. The treated cells were counted, resuspended in growth medium containing 10% FBS, 2 mM L-glutamine, 1 mM sodium pyruvate, 100 U/mL penicillin and 100 μ g/mL streptomycin, and transferred into the 24-well plate at the density of 1.1×10^5 cells per well. Three random photos were taken per well after 6 h.

Enzyme-Linked Immunosorbent Assay (ELISA)

Specific ELISA (MEIMIAN, MM-1900H2) kits were utilized to assess plasma levels of human soluble vascular endothelial growth factor receptor 1 (sFlt-1) and corticosterone (CORT) after the cold exposure. The ELISA test kit was used to measure the quantity of sFlt-1 in the supernatant of different groups of HTR8/SVneo cells (Enzyme Exemption, BH-C236).

Statistical Analysis

All data was expressed as means \pm SEM. Statistical analysis was done using IBM SPSS Statistics 22 (IBM Corp., Armonk, NY, USA). The normal distribution was evaluated by the Shapiro-Wilk test. Statistical significance was determined based on the homogeneity of sample distribution and variance. A statistical comparison between the two groups was determined by the two-tailed Student's *t*-test and the Mann-Whitney U test. For multiple comparisons, the Bonferroni post-hoc test, two-way ANOVA with a simple effect test, Kruskal-Wallis test, and Dunn's multiple comparison test were used. $p < 0.05$ was considered statistically significant. No samples were excluded from the analysis.

Results

Relationship Between Cold Exposure and Physiological Indexes During Pregnancy

The included rats ($n=30$, 20 females and 10 males) were divided into 5 groups, 6 animals in each group, 4 females and 2 males (female to male ratio of 2:1). Rats in Gp.1 were treated with cold exposure (CE) preconception; Gp.2 CE during the first week of pregnancy; Gp.3 CE during the second week of pregnancy; Gp.4 CE during the third week of pregnancy, and Gp.5 contained control (no CE) rats. The physiological indexes of pregnant rats, as well as the levels of corticosterone and soluble fms-like tyrosine kinase-1 (sFlt-1, a truncated form of VEGF receptor), were measured at different stages of pregnancy. The results showed that cold exposure was not associated with significant changes in systolic blood pressure (SBP) in pregnant rats (Figure 3A). On the other hand, the diastolic blood pressure (DBP) of rats in Gp.1 (pre-pregnancy cold exposure) increased significantly compared to the control group (Figure 3B), even after the cold exposure was discontinued. Cold exposure was not associated with significant changes in the mean arterial pressure (MAP) increased throughout pregnancy (Figure 3C). The feed intake of pregnant rats decreased during cold exposure (Figure 4A), but the difference was not statistically significant, and the food intake recovered after cold exposure was removed. There was no significant between-group difference in gestational weight gain (Figure 4B) and the number of live births (Figure 4C). Rats,

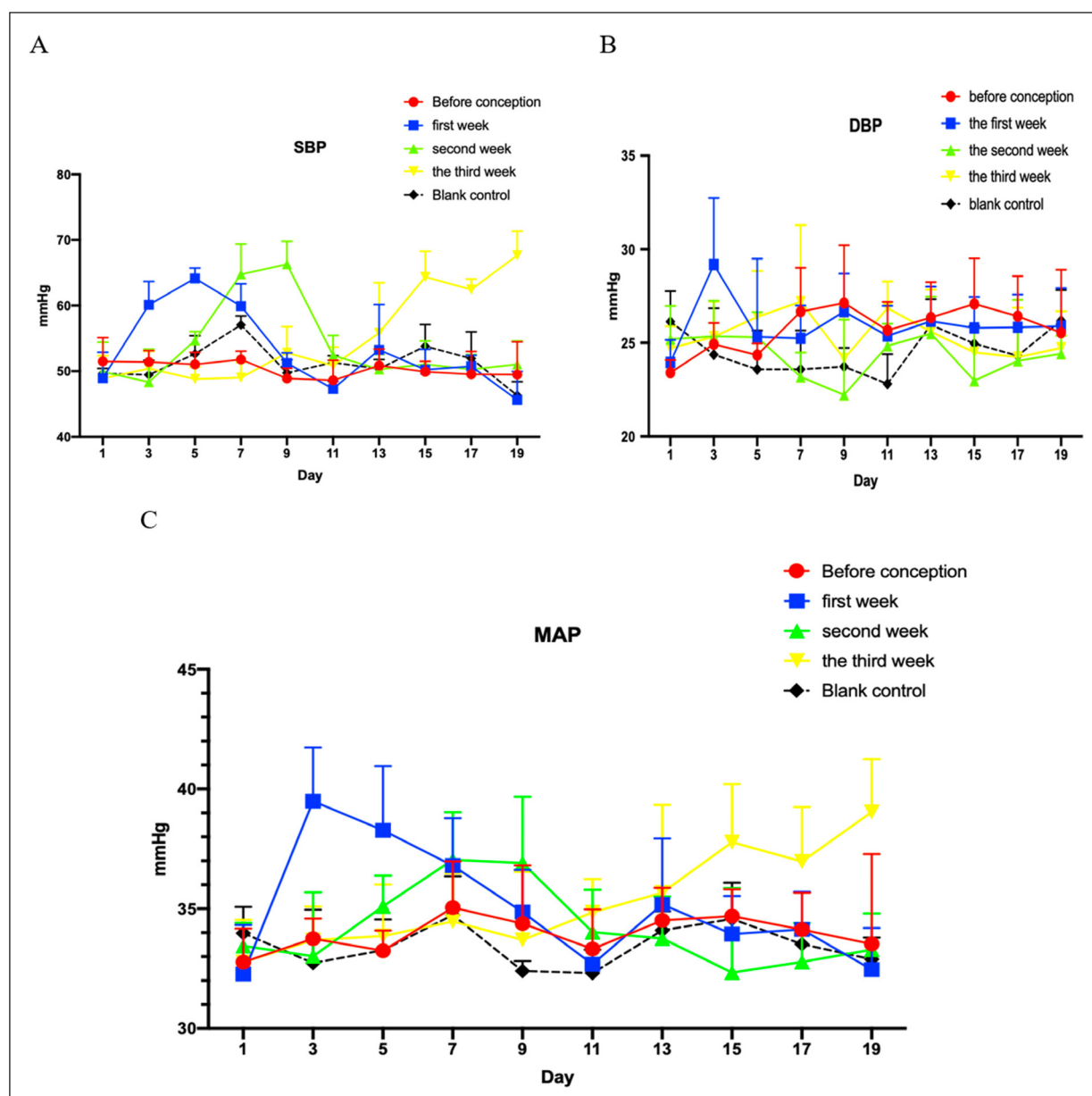

Figure 3. Blood pressure changes in pregnant rats exposed to cold at different times (n=4). Microscopic examination of a vaginal smear verified the presence of sperm in pregnant rats and determined the gestational day (GD) to be 0. Blood pressure was measured from GD 0 to GD 19.5. **A,** Changes in SBP during pregnancy. **B,** Changes in DBP during pregnancy. **C,** Changes in MAP during pregnancy. MAP: mean arterial pressure; DBP: diastolic blood pressure; SBP: systolic blood pressure; $MAP=(SBP+2\times DBP)\div 3$.

exposed to cold during the second week of gestation (Gp.3) had significantly lower placental weight (Figure 4D) compared to the control group ($p=0.0003$). Cold exposure in the third week was associated with significantly ($p=0.001$) lower fetal weight (Figure 4E). There was a persistent effect of cold exposure on serum corticosterone (Figure

4F) and sFlt-1 (Figure 4G) in pregnant rats, and cold exposure pre-conception led to consistently increasing serum corticosterone and sFlt-1 levels throughout pregnancy (Table II). Even after discontinuing cold exposure, cortisol levels throughout pregnancy were higher than in the control group without cold exposure (Figure 4F-H).

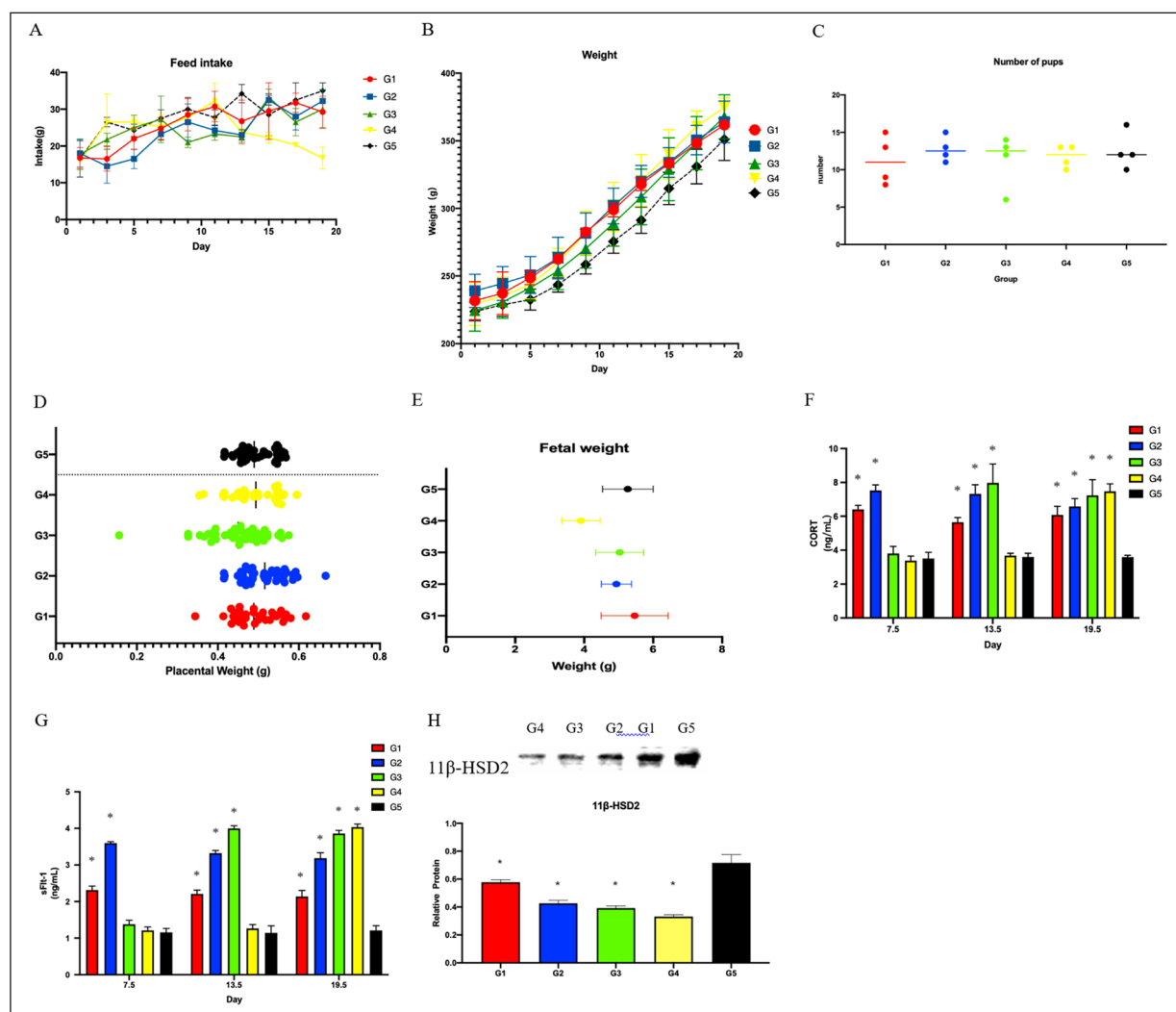

Figure 4. Changes in physiological markers were examined in various groups during pregnancy, from GD 0 to 19.5. **A**, Changes in food intake during pregnancy. **B**, Changes in weight during pregnancy. **C**, Number of newborns. **(D)**, Placenta weight. **E**, Fetal weight. **F**, Corticosterone levels in maternal circulation. *Indicated compared to the control group (n=4, *p<0.05). **G**, The levels of sFlt-1 in maternal circulation. **H**, Protein expression of 11β-HSD2 compared to the blank control group (n=4, *p<0.05). Gp.1: cold exposure before conception, Gp.2: cold exposure in the first week after conception, Gp.3: cold exposure in the second-week post-conception, Gp.4: cold exposure in the 3rd week post-conception, and Gp.5: control group without cold exposure. sFlt-1: Soluble fms-like tyrosine kinase-1, CORT: corticosterone.

Table II. Maternal preconception cold exposure and expression of 11β-HSD2 and vascular endothelial growth factors.

	M-CE		MF-CE		F-CE		Control		p-value
	Mean	SD	Mean	SD	Mean	SD	Mean	SD	
11β-HSD2	0.8179	0.0404	0.521	0.015	0.4575	0.0586	0.7061	0.0443	0.02*
GR	1.063	0.0328	0.613	0.0567	0.5171	0.0535	0.8976	0.0333	0.02*
VEGF-A	1.4636	0.0327	0.9512	0.0544	0.8768	0.0699	1.3253	0.0193	0.02*
PlGF	1.1224	0.04	0.7639	0.0531	0.69	0.0415	0.976	0.043	0.03*
sFlt-1	1.179	0.0542	0.7053	0.057	0.6135	0.0518	0.9949	0.0596	0.02*

*p<0.05 defined as a significant difference.

11-hydroxysteroid dehydrogenase 2 (11β-HSD2), Glucocorticoid receptor (GR), vascular endothelial growth factor (VEGF), Placental growth factor (PlGF), Soluble fms-like tyrosine kinase-1 (sFlt-1).

Paternal and Maternal Preconception Cold Exposure Effect on the Placenta in Early Pregnancy

Rats of different sexes were grouped based on whether they had been exposed to the environmental cold before conception. The first day of the vaginal plug was defined as GD0 (gestation day). The placenta detection indicators of pregnant rats were taken at GD 7.5 (Figure 5A). As shown in

Figure 5B and Table II, expression levels of 11-HSD2, Glucocorticoid receptor, VEGF-A, PlGF, and sFlt-1 proteins showed a significant downward regulation trend in cold-exposure female rats before pregnancy compared to no-cold-exposed rats (n=3, * $p < 0.05$). No significant changes were observed in the male cold-exposure (M-CE) group compared to no-cold-exposed rats (n=3, $p > 0.05$).

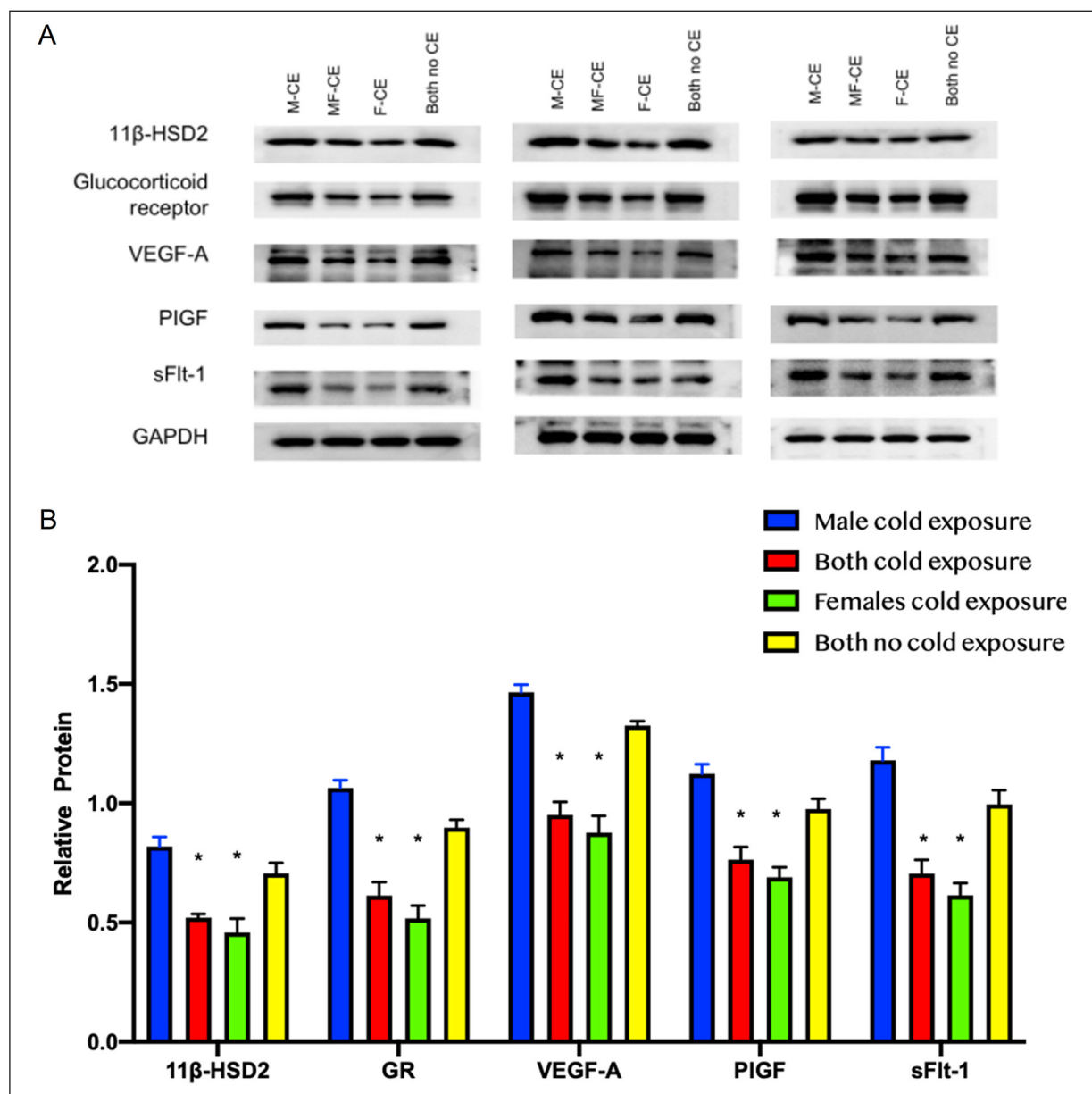

Figure 5. Rats were grouped based on the pre-conception exposure to cold. All rats were kept at 25°C after conception. Placental levels of 11β-HSD2, glucocorticoid receptor, VEGF-A, PlGF, and sFLT-1 were measured at GD 7.5. * **A.** Western blot analysis of placental proteins; **B.** Quantification of the placental levels of 11β-HSD2, GR, VEGF-A, PlGF, and sFLT-1. *Indicates significant difference ($p < 0.05$). 11β-HSD2: 11 β-hydroxysteroid dehydrogenase 2; VEGF: vascular endothelial growth factor; PlGF: Placental growth factor; sFlt-1: Soluble fms-like tyrosine kinase-1.

Immunofluorescent Detection of Cytokeratin, Laminin and α -Actin in Placental Tissue in the First Week of Pregnancy

Animals in female cold exposure (F-CE) and male cold exposure (M-CE) groups were exposed to cold for 7 days before initiating a mating. All rats were kept at 25°C after the treatment. CK and LN of trophoblasts, and α -actin in vascular smooth muscle of the spiral arteries of pregnant rats after the systemic cold treatment were assessed by immunofluorescent and visualized by fluorescent microscopy at x200 magnification. The results of immunofluorescent staining showed that the expression of CK and LN in female rats who experienced cold exposure before conception was reduced, but there was no significant difference compared to the control group without cold exposure. The expression of α -actin in female rats experiencing cold exposure before conception was significantly reduced compared to that in the control group (n=8, * p <0.05). No difference was detected when male rats were exposed to cold (**Supplementary Figure 2**).

11 β -HSD2 Levels Affect the Placental Recasting Process

Three siRNA constructs (412, 545, and 925) were transfected into HTR8 cells, and the expression levels of the 11 β -HSD2 gene in each group were measured using qPCR. The results indicated that transfection with all three siRNA significant-

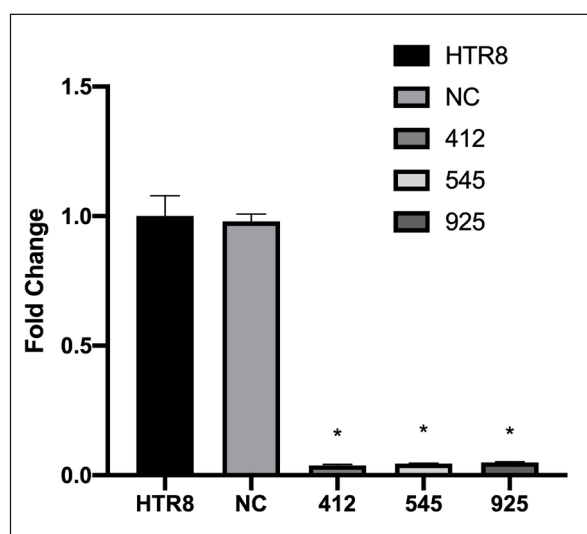

Figure 6. 11 β -HSD2 gene significantly reduced by transfecting with siRNA (p <0.05). *Indicated compared to HTR8 group.

ly decreased the expression of the 11 β -HSD2 gene (p <0.05). Of the constructs used, the 412 siRNA was the most effective and was subsequently used for further experiments (Figure 6).

We examined the number of migrating and invading HTR8 cells in the control siRNA group and in cells transfected with the 11 β -HSD2 siRNA using the Transwell migration assay (Figure 7A). Cell migrations and invasion were considerably reduced in the 11 β -HSD2 siRNA experimental group compared to the control siRNA group (p <0.05) (Figure 7B).

Expression levels of sFlt-1 protein in each group were measured by ELISA. The experimental results showed that the levels of sFlt-1 protein in the transfection group were significantly higher than those in the control group (p <0.05). This result indicates that transfection by siRNA plasmids enables upregulation of sFlt-1 protein expression (Figure 8).

Discussion

In this study, we demonstrated for the first time that environmental cold exposure before conception is associated with an increase in GCs during pregnancy. In addition, using cultured human placental trophoblasts, we showed that reducing 11 β -HSD2 levels correlated with sFlt-1 upregulation, which can potentially lead to inadequate trophoblast infiltration, placental abnormalities, and decreased placental blood flow in early pregnancy. Our study found that the downregulation of 11 β -HSD2 can significantly inhibit migration and invasion capacity of trophoblasts, promote the release of sFlt-1, and thus inhibit the formation of placental blood vessels. These data strongly indicate that environmental cold exposure before conception plays a critical role in placental angiogenesis, possibly through a mechanism that involves GC-induced dysregulation of placental 11 β -HSD2.

Environmental Stress Exposure and Abnormal Placental Vascular Remodeling

The placenta is a highly vascularized organ. New blood vessels are formed by the budding of the capillaries from the original blood vessels, ensuring the increased maternal and fetal oxygen supply demands. This formation and development of blood vessels is the premise for ensuring the proper function of the placenta. Helical arteries

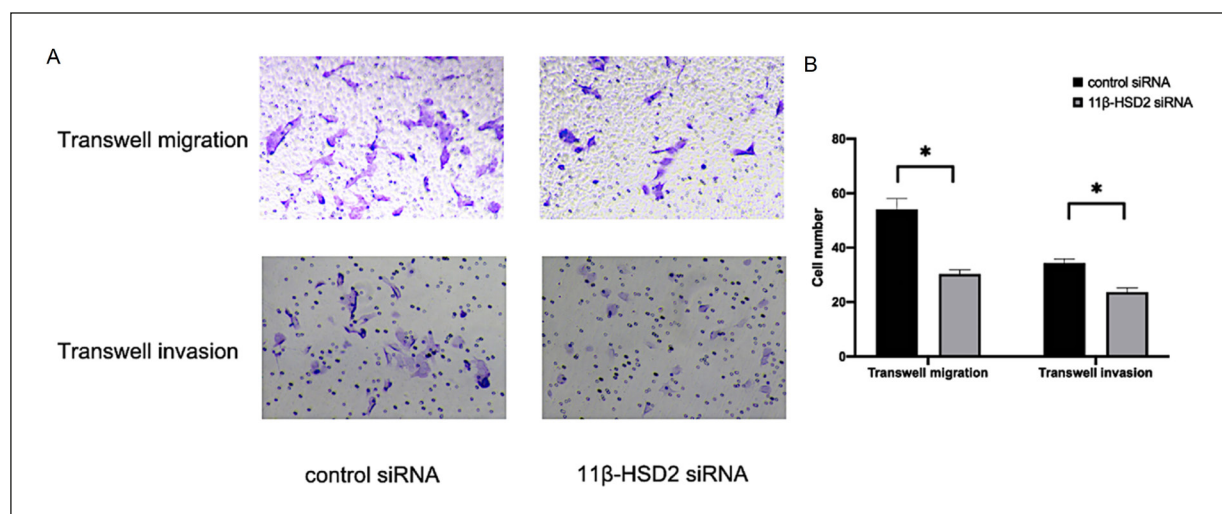

Figure 7. Migration and invasion of cells with 11β-HSD2 expression reduced by siRNA treatment. Cells were visualized at ×200 magnification. **A.** Transwell migration and invasion assay; **B.** Quantitative analysis of cell migration and invasion. *Indicated compared to the control siRNA group ($p < 0.05$).

complete placental vascular recasting through dilation, degradation of elastin, and destruction of vascular smooth muscle cells (VSMC). In this process, the elastic layer of vascular smooth muscle is replaced by an inert fibrous substance, transforming the spiral artery of the decidua and part of the myometrium into a relaxed, low-resistance, high-throughput uterine-placental artery. Vascular recasting results in a 4-6-fold increase in the diameter of the uterine spiral that ensures unimpeded blood flow and sufficient exchange of oxygen and other key molecules between the maternal and fetal circulation¹⁹. Vascular endothelial growth factors are pro-angiogenic factors that play an important role in the placental vascular recasting process. Among them, VEGF-A, VEGF-B and PlGF bind to VEGFR1 (Flt-1), which is expressed on trophoblasts to induce trophoblast invasion and spiral artery recasting. Abnormalities in the spiral artery recasting process can lead to a range of placenta-mediated pregnancy complications (PMPC), including recurrent miscarriage, fetal growth restriction, and preeclampsia²⁰. Pathological biopsy of placental specimens in PE patients showed that the uterine spiral artery vascular recasting was superficial, limited to the decidua layer, and the proximal segment of the spiral artery was narrowed, with an average diameter of only 200 μm. Placental vascular recasting in normal pregnancy involves the superficial myometrium with an average lumen diameter of 500 microns²¹.

Pregnant women with underlying diseases and pathological conditions, including hypertension, kidney disease, diabetes, autoimmune diseases such as systemic lupus erythematosus, antiphospholipid syndrome, etc., are at higher risk of developing PE. Studies have shown that more than 40% of patients with PE have mater-

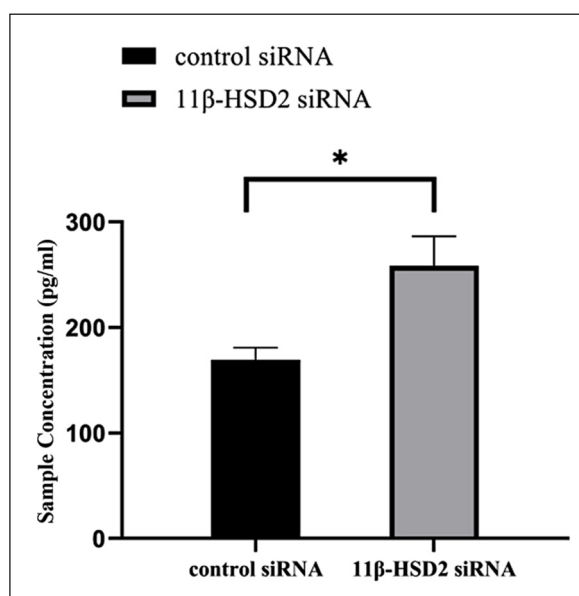

Figure 8. Expression levels of sFlt-1 protein. HTR8 cells were transfected with 11β-HSD2 siRNA or control siRNA, and the levels of sFlt-1 protein were assessed by ELISA; $p < 0.05$. * Indicates significant difference ($p < 0.05$).

nal underlying pathological conditions that are associated with an early onset, a high incidence of severe disease, and an early gestational age²². Therefore, comprehensive assessment of high-risk factors for PE and effective management of controllable risk factors during early pregnancy or at the first diagnosis have always been important elements of PE prevention and treatment. The first trimester is a critical period for placental formation and completion of the vascular recasting process. Different stressors, such as malnutrition or hypoxia and external environmental stimuli, may alter the placental morphological structure to varying degrees, thereby affecting the transport of placental nutrients and metabolic waste, hormone secretion, and barrier function, and this effect may last throughout pregnancy. Previous studies²³ linked maternal exposure to cold spells (in regions where cold months may account for over half of a year, such as Eastern Europe and China) in certain periods of pregnancy to increased risk of developing diabetes mellitus in the offspring. A recent study²⁴ of more than 2 million pregnant women also showed that exposure to extreme cold preconception (12 weeks) increases the risk of PE and this risk decreases with increasing temperature. Our study also shows that cold exposure before conception and early pregnancy has a persistent effect on the BP of the animal model, suggesting that some adverse stressors of the external environment before conception and early pregnancy can affect placental function through the regulation of the placental vascular recasting process, and even lead to placenta-derived pregnancy complications and further affect the intrauterine environment. Our results showed that cold exposure at the second and third weeks of pregnancy led to significantly lower placental and fetal weights, respectively, in the rat model of cold exposure. We also showed a decreased number of CK-positive infiltrating trophoblast cells and reduced α -actin staining in the vascular smooth muscle of female rats exposed to cold before conception. These results indicated that cold exposure of female rats before conception could affect the migration and invasion behavior of placental trophoblasts in early pregnancy.

Glucocorticoids Affect the Expression of Placental 11 β -HSD2

Glucocorticoids (GCs) are important steroid hormones produced in response to stress. GCs are regulated by the hypothalamic-pituitary-adrenal axis (HPA) and play a key role in many physio-

logical processes of the body. There is increasing evidence¹⁸ of the inhibitory effect of GCs on angiogenesis that is widely used in the treatment of prostate cancer, corneal neovascularization, cardiovascular disease, and nephropathy. Studies²⁵ in pregnant rats also showed that the placental area was reduced in animals treated with dexamethasone injection between the 16th and 20th day of gestation compared to the control group, suggesting that excess maternal exposure to GC inhibits the growth and development of placental vessels in rats. Therefore, it is plausible that elevated maternal GC levels due to the stress of cold stimulation before conception may cause placental vascular recasting abnormalities by inhibiting VEGFs, thereby affecting placental function. The results of our study suggest that cold exposure stimulation in female rats before conception and in early pregnancy can be manifested as a continuous increase in GCs and sFlt-1 levels during pregnancy, and decreased expression of VEGF-A and PlGF. These changes may result in placental vascular recasting disorders in early pregnancy and a continuous increase in diastolic blood pressure throughout pregnancy, even after cold stimulation is stopped.

11 β -HSD2 Levels Affect the Placental Vascular Remodeling Process

Elevated GCs in early pregnancy affect placental growth by inhibiting placental vascularization and may affect placental function by reducing the expression and activity of 11 β -HSD2 in the trophoblasts. A study¹⁴ showed that pregnant women with severe anxiety had significantly elevated levels of GCs in amniotic fluid compared to mothers with mild anxiety, and these levels negatively correlated with the placental 11 β -HSD2 mRNA expression and activity. Animal studies²⁶ have found that subcutaneous injection or placenta-targeted administration of the 11 β -HSD2 inhibitor carbenoxolone (CBX) in pregnant rats can lead to inhibition and decreased activity of placental 11 β -HSD2 expression, and increased levels of placental and fetal circulating GCs. This led to characteristic signs of PE in pregnant rats, including hypertension, proteinuria, and renal damage. In addition, postpartum placental pathology in patients with fetal growth restriction (FGR) shows decreased expression of 11 β -HSD2 with hypermethylation of the promoter encoding the 11 β -HSD-2 protein gene²⁷. These results suggested that the regulation of placental 11 β -HSD2 expression affected placental function and that this

effect was mediated by the increased expression of GCs as a response to adverse environmental stress. In our study, siRNA (412) effectively inhibited the expression level of the *11 β -HSD2* gene in trophoblast cells, inhibited cell invasion and migration, effectively increased the expression level of human sFlt-1 protein, and greatly reduced blood vessel formation.

A limitation of this study is that the mechanism by which decreased expression of 11 β -HSD2 promotes sFlt-1 protein expression was not identified. It is well known that an imbalance of placental growth factor (PLGF) and anti-angiogenic sFlt-1 in the circulatory system play a main role in the pathogenesis of placental dysfunction. However, the mechanism of GC regulating the expression of vasoactive factors in trophoblast cells needs to be further studied. In addition, the dynamic and delicate interaction between various cells of the maternal-fetal interface microenvironment, including trophoblast cells, decidua cells, vascular endothelial cells, vascular smooth muscle cells, as well as a variety of immune cells, ensures the smooth completion of the recasting process. GCs have an important regulatory effect on immunity, and elevated maternal GCs signaling in early pregnancy may also affect the placental vascular recasting process by affecting the maternal-fetal immune microenvironment. Studies²⁸ have shown that T cell infiltration and angiogenesis occur simultaneously, and PLGF is not only produced by T helper cells 17 (TH17), but also induces their differentiation. This suggests a correlation between angiogenesis and regulation of immune function, which needs to be further studied.

Conclusions

In conclusion, our study has proved that cold exposure can cause increased levels of GCs and downregulation of 11 β -HSD2 in the pregnant rat model. Reduced expression of placental 11 β -HSD2 can lead to impaired extravillous trophoblast migration and invasion and increased levels of sFlt-1, inhibiting the formation of placental blood vessels. This may affect the placental vascular recasting process to varying degrees in early pregnancy and change the placental morphological structure and function (**Supplementary Figure 1**). Therefore, our findings provide *in vivo* evidence that reducing adverse internal and external environmental stress plays a key role in the pathogenesis of PE.

Authors' Contributions

Qinjian Zhang and Siwen Chen designed the analyses, and Qinjian Zhang drafted the manuscript. Jianying Yan conceptualized the study; and Xia Xu and Huale Zhang contributed to data acquisition. All authors have revised the manuscript for important intellectual content. All authors have read and agreed to the published version of the manuscript.

Funding

This study was funded by the Natural Science Foundation of Fujian, 2021J01425 and Joint Funds for the Innovation of Science and Technology, Fujian province (2020Y9401).

Ethics Approval

All animal procedures were carried out in accordance with the guidelines for the use of laboratory animals published by the People's Republic of China Ministry of Health (January 25, 1998) with the approval of the Ethics Committee of the Fujian Provincial Maternity and Children's Hospital (2021KD).

Informed Consent

Not applicable.

Data Availability

The datasets generated during and analyzed during the current study are available from the corresponding author upon reasonable request.

Conflicts of Interest

The authors declare no conflict of interest. The funders had no role in the design of the study, in the collection, analyses, or interpretation of data, in the writing of the manuscript, or in the decision to publish the results.

References

- 1) Moisiadis VG, Matthews SG. Glucocorticoids and fetal programming part 1: Outcomes. *Nat Rev Endocrinol* 2014; 10: 391-402.
- 2) Bronson SL, Bale TL. The Placenta as a Mediator of Stress Effects on Neurodevelopmental Reprogramming. *Neuropsychopharmacology* 2016; 41: 207-218.
- 3) Eberle C, Ament C. Diabetic and metabolic programming: mechanisms altering the intrauterine milieu. *ISRN Pediatr* 2012; 2012: 975685.
- 4) Bronson SL, Bale TL. Prenatal stress-induced increases in placental inflammation and offspring hyperactivity are male-specific and ameliorated by maternal antiinflammatory treatment. *Endocrinology* 2014; 155: 2635-2646.
- 5) Pratt WB, Morishima Y, Murphy M, Harrell M. Chaperoning of glucocorticoid receptors. *Handb Exp Pharmacol* 2006; 111-138.

- 6) De Bosscher K, Beck IM, Dejager L, Bougarne N, Gaigneaux A, Chateauvieux S, Ratman D, Bracke M, Tavernier J, Vanden Berghe W, Libert C, Diederich M, Haegeman G. Selective modulation of the glucocorticoid receptor can distinguish between transrepression of NF- κ B and AP-1. *Cell Mol Life Sci* 2014; 71: 143-163.
- 7) Pofi R, Tomlinson JW. Glucocorticoids in pregnancy. *Obstet Med* 2020; 13: 62-69.
- 8) Busada JT, Cidlowski JA. Mechanisms of Glucocorticoid Action During Development. *Curr Top Dev Biol* 2017; 125: 147-170.
- 9) Kroon J, Pereira AM, Meijer OC. Glucocorticoid Sexual Dimorphism in Metabolism: Dissecting the Role of Sex Hormones. *Trends Endocrinol Metab* 2020; 31: 357-367.
- 10) Garrud TAC, Giussani DA. Combined Antioxidant and Glucocorticoid Therapy for Safer Treatment of Preterm Birth. *Trends Endocrinol Metab* 2019; 30: 258-269.
- 11) Yavuz A, Küçükbas GN, Hacıoğlu Maternal U Y, Niyazoglu M, Alcalar N, Hatipoğlu E. Third trimester physiological hypercortisolemia may protect from postpartum depression and stress. *Eur Rev Med Pharmacol Sci* 2023; 27: 3016-3021.
- 12) Krontira AC, Cruceanu C, Binder EB. Glucocorticoids as Mediators of Adverse Outcomes of Prenatal Stress. *Trends Neurosci* 2020; 43: 394-405.
- 13) Wyrwoll CS, Holmes MC, Seckl JR. 11 β -Hydroxysteroid dehydrogenases and the brain: from zero to hero, a decade of progress. *Front Neuroendocrinol* 2011; 32: 265-286.
- 14) Wang G, Huang Y, Hu T, Zhang B, Tang Z, Yao R, Huang Y, Fan X, Ni X. Contribution of placental 11 β -HSD2 to the pathogenesis of preeclampsia. *FASEB J* 2020; 34: 15379-15399.
- 15) Chapman K, Holmes M, Seckl J. 11 β -hydroxysteroid dehydrogenases: intracellular gate-keepers of tissue glucocorticoid action. *Physiol Rev* 2013; 93: 1139-1206.
- 16) Hunter RW, Bailey MA. Glucocorticoids and 11 β -hydroxysteroid dehydrogenases: mechanisms for hypertension. *Curr Opin Pharmacol* 2015; 21: 105-114.
- 17) Glover V, Bergman K, Sarkar P, O'Connor TG. Association between maternal and amniotic fluid cortisol is moderated by maternal anxiety. *Psychoneuroendocrinology* 2009; 34: 430-435.
- 18) Chotiarnwong P, McCloskey EV. Pathogenesis of glucocorticoid-induced osteoporosis and options for treatment. *Nat Rev Endocrinol* 2020; 16: 437-447.
- 19) Brosens I, Puttemans P, Benagiano G. Placental bed research: I. The placental bed: from spiral arteries remodeling to the great obstetrical syndromes. *Am J Obstet Gynecol* 2019; 221: 437-456.
- 20) Phipps EA, Thadhani R, Benzing T, Karumanchi SA. Pre-eclampsia: pathogenesis, novel diagnostics and therapies. *Nat Rev Nephrol* 2019; 15: 275-289.
- 21) Aplin JD, Myers JE, Timms K, Westwood M. Tracking placental development in health and disease. *Nat Rev Endocrinol* 2020; 16: 479-494.
- 22) Reale SC, Camann WR. Preeclampsia. *N Engl J Med* 2022; 387: 286-287.
- 23) Vallianou NG, Geladari EV, Kounatidis D, Geladari CV, Stratigou T, Dourakis SP, Andreadis EA, Dalamaga M. Diabetes mellitus in the era of climate change. *Diabetes Metab* 2021; 47: 101205.
- 24) Xiong T, Chen P, Mu Y, Li X, Di B, Li J, Qu Y, Tang J, Liang J, Mu D. Association between ambient temperature and hypertensive disorders in pregnancy in China. *Nat Commun* 2020; 11: 2925.
- 25) Ozmen A, Unek G, Korgun ET. Effect of glucocorticoids on mechanisms of placental angiogenesis. *Placenta* 2017; 52: 41-48.
- 26) Wang G, Huang Y, Hu T, Zhang B, Tang Z, Yao R, Huang Y, Fan X, Ni X. Contribution of placental 11 β -HSD2 to the pathogenesis of preeclampsia. *FASEB J* 2020; 34: 15379-15399.
- 27) Cotechini T, Komisarenko M, Sperou A, Macdonald-Goodfellow S, Adams MA, Graham CH. Inflammation in rat pregnancy inhibits spiral artery remodeling leading to fetal growth restriction and features of preeclampsia. *J Exp Med* 2014; 211: 165-179.
- 28) Yoo SA, Kim M, Kang MC, Kong JS, Kim KM, Lee S, Hong BK, Jeong GH, Lee J, Shin MG, Kim YG, Apicella I, Cicatiello V, De Falco S, Yoon CH, Cho CS, Ryoo ZY, Lee SH, Kim WU. Placental growth factor regulates the generation of TH17 cells to link angiogenesis with autoimmunity. *Nat Immunol* 2019; 20: 1348-1359.