



Government of West Bengal
Irrigation & Waterways Department
Jalasampad Bhaban, 3rd Floor, Western Block
Bidhannagar, Salt Lake City, Kolkata 700091

Memo No. 501 – IFC
IW/O/IFC/4M-30/2014

Dated, 10th December 2019

MEMORANDUM

With a view to taking a holistic approach to evolve appropriate technical solution to the problem of erosion in river and sea-coast in various districts of the State in consideration of hydro-morphological condition of the rivers, characteristics of riverbank and sea-beach materials, availability of construction materials for protection of riverbanks or sea-coast, a Technical Experts' Committee (TEC), headed by Dr. D Sen, Professor, Department of Civil Engineering, IIT Kharagpur, Dr. S. Mukherjee, Professor, Department of Civil Engineering, Jadavpur University and various other Engineers Officers of this Department was constituted vide Memo No.200-IFC/IW/O/4M-30/2014 dated 10th September 2014.

2. The TEC, after holding detailed deliberation on various pertinent issues including review of existing provision of BIS Codes and other guidelines of CWC, IRC, etc. and also the standard practices of this Department in six meetings, has brought out detailed guidelines on standardization of riverbank protection and coastal protection works for different districts of the State, clustered in five zones in the form of a Manual, that were circulated to all concerned, vide I&WD Memo No. 93-IFC dated 26th March 2018.

3. While using the provisions of the guidelines during last one year and seven months, a few filed application issues were cropped up as reported by the field level officials. As a part of embracing new technological developments, a few new concepts in the river bank and coastal protections have also piloted successfully during this period and experience of these projects is now required to be shared with all concerned, through incorporation in the manual. Accordingly, The TEC, after reviewing the provisions of the existing guidelines and deliberating on the relevant issues in its 7th meeting held on 12th November 2019, has suggested new sets of guidelines, envisaging modifications of existing guidelines in a few cases and also incorporation of new guidelines.

4. Accordingly, “Guidelines for Riverbank protections & Anti-Sea Erosion work in West Bengal (1st Amendment)” in suppression of the existing guidelines has been brought out and enclosed herewith as Annex. The said guidelines are to be used henceforth, for preparation of all schemes relating to river bank and coastal protection, except in special cases, as stated in the said guidelines.
5. These guidelines will have effect from 1st December 2019. Schemes already cleared by the Departmental Screening Committee before that date, need not be modified.
6. All concerned may accordingly be informed.

Sd/-
(Naveen Prakash)
Additional Chief Secretary to the
Government of West Bengal

Encl. Annex

No.501/1(12) – IFC

Dated, 10th December 2019

Copy with copy of Annex forwarded for information to:

- 1 Dr. Dhrubajyoti Sen
Head, School of Water Resources
IIT Kharagpur
District Paschim Medinipur – 721302
- 2 Dr. Sibapriya Mukherjee
Professor, Department of Civil Engineering
Jadavpur University
188, Raja S C Mallick Road
Kolkata – 700032
- 3 The Chairman
Ganga Flood Control Commission
Government of India
Sinchai Bhawan, 3rd Floor
Patna, Bihar – 800015
- 4 The Chairman
Brahmaputra Board
MoWR, RD & GR, Government of India
NH 37, Basishta, Guwahati, Assam 781029
- 5 The Chief Engineer (B & BBO)
Central Water Commission
Government of India
“Maranatha” Pokhesh, P.O. Rynjah (Upling)
Shillong, Meghalaya – 793006

- 6 The Chief Engineer (TBO)
Central Water Commission
Government of India
Sevoke Road, 2nd Mile
Siliguri, West Bengal – 734401
- 7 The Principal Accountant General
(Economic & Revenue Sector Audit)
MSO Building, CGO Complex, 5th Floor
Block-DF, Sector-I, Bidhannagar
Kolkata – 700064
- 8 The Principal Accountant General (Audit)
Treasury Building, 2, Government Place (West)
Kolkata – 700001
- 9 The Engineer in Chief & E.O Secretary
Public Works & Public Works (Roads) Department
Government of West Bengal
Nabanna, 325, Sarat Chatterjee Road
Shibpur, Howrah – 711102
- 10 Finance (Audit) Department, Group –F
Government of West Bengal
Nabanna, 325, Sarat Chatterjee Road
Shibpur, Howrah – 711102
- 11 The General Manager
National Bank for Agriculture & Rural Development
Abhilasha, 2nd Floor,
6 Royd Street, Kolkata – 700016
- 12 Financial Adviser & E.O Special Secretary
Irrigation & Waterways Department

Encl. as stated

(D SenGupta)
 Joint Secretary to the
 Government of West Bengal

No. 501 /2(7) – IFC

Dated, 10th December 2019

Copy with copy of Annex forwarded for information to:

- 1 Chief Engineer
Teesta Barrage Project
Irrigation & Waterways Directorate
- 2 Chief Engineer (North East)
Irrigation & Waterways Directorate
- 3 Chief Engineer (North)
Irrigation & Waterways Directorate
- 4 Chief Engineer (West)
Irrigation & Waterways Directorate
- 5 Chief Engineer (South West)
Irrigation & Waterways Directorate
- 6 Chief Engineer (South)
Irrigation & Waterways Directorate
- 7 Chief Engineer (D & R)
Irrigation & Waterways Directorate

All officers under his control may please be informed.

(D SenGupta)

Joint Secretary to the
Government of West Bengal

Encl. as stated

No. 501/3 – IFC

Dated, 10th December 2019

Copy with copy of Annex forwarded for information to:

Sujay Saha
OSD & Deputy Secretary III
Irrigation & Waterways Department
– with a request to upload this Order and also separately the guidelines on the
departmental website in the Home Page.

Encl. as stated

(D SenGupta)

Joint Secretary to the
Government of West Bengal



**GUIDELINES ON
RIVERBANK PROTECTION
&
ANTI-SEA EROSION
WORKS IN WEST BENGAL**

(1ST AMENDMENT)

**GOVERNMENT OF WEST BENGAL
IRRIGATION & WATERWAYS DEPARTMENT**

DECEMBER 2019

Guidelines on Riverbank Protection & Anti-Sea erosion Works In West Bengal (1st Amendment)

1.0 INTRODUCTION

This manual provides guidelines for planning and design of bank protection measures for the rivers and sea-coasts of West Bengal. Since the nature and characteristics of these rivers vary considerably (Figure 1), the manual discusses the following:

- (a) The general considerations that have to be borne in mind while planning/selecting the protection works;
- (b) The specific measures that are appropriate for protecting the banks of rivers and sea-faces.

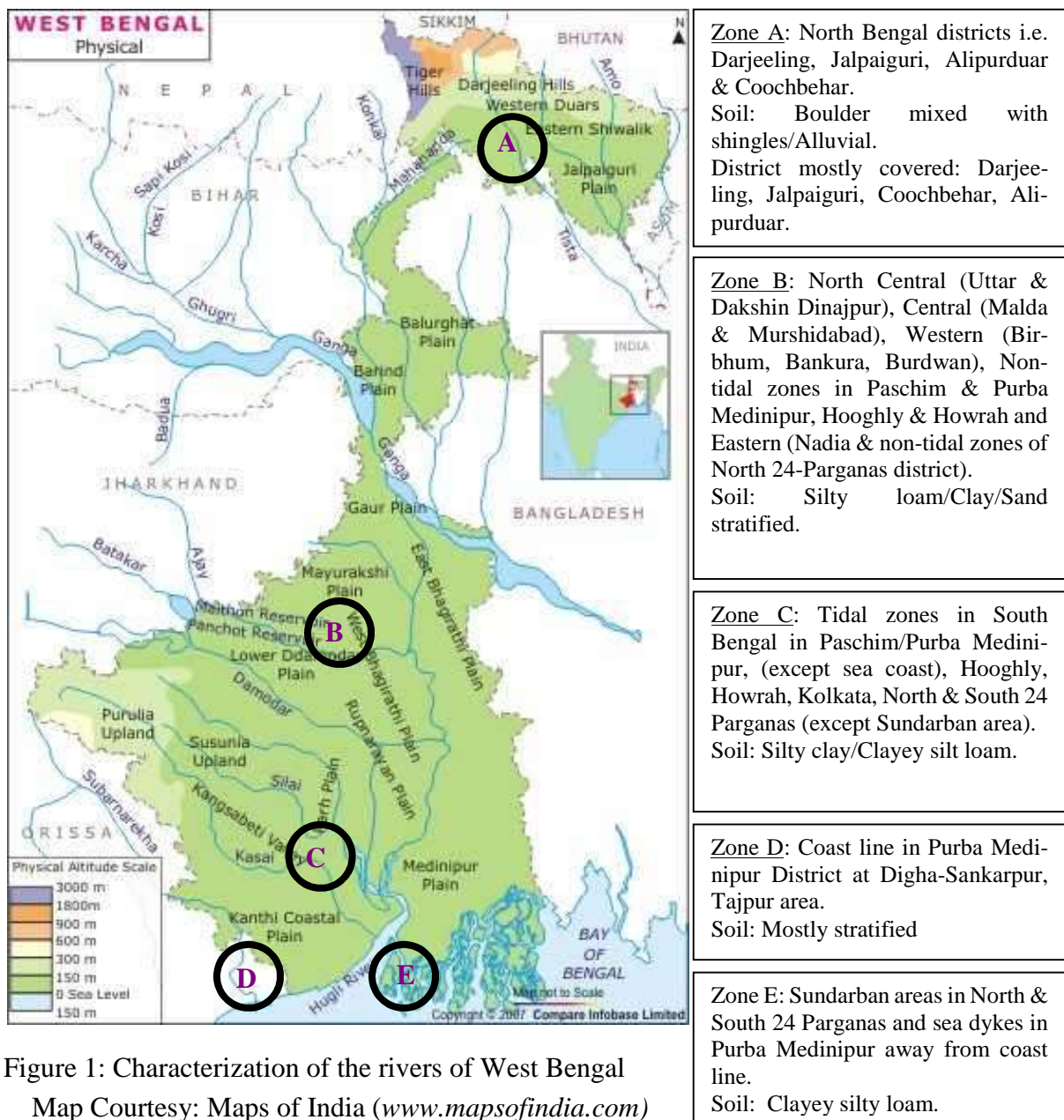

Figure 1: Characterization of the rivers of West Bengal
Map Courtesy: Maps of India (www.mapsofindia.com)

2.0 REFERENCES

The following national and international standards / manuals / guidelines have been referred to while framing this manual. These and any other text appropriate to the subject may be referred to, while framing a proposal on bank protection measure at a site.

- (a) BIS (1995) IS: 14262 “Planning and design of revetment – Guideline”
- (b) BIS (2013) IS: 14262 “Planning and design of revetment – Guideline”
(Draft Revision)
- (c) CWC (2012) “Handbook for Flood Protection, Anti-erosion and River-training Works”, Central Water Commission, New Delhi.
- (d) WES (1997) “The WES Stream Investigation and Stream Stabilization Handbook”, U. S. Army Waterways Experimentation Station, Vicksburg, Mississippi, USA.
Available in public domain at the following website:<http://chl.erdc.usace.army.mil/Media/2/8/7/StreambankManual.pdf>
- (e) USACE (1991) “Hydraulic Design of Flood Control Channels, EM-1110-2-1601”, U.S. Army Corps of Engineers (1991), USA.
Available in public domain at the following website:http://www.publications.usace.army.mil/Portals/76/Publications/EngineerManuals/EM_1110-2-1601.pdf
- (f) BC (2000) “Riprap design and construction guide”, Public Safety Section, Water Management Branch, Province of British Columbia, Canada
Available in public domain at the following website:http://www.env.gov.bc.ca/wsd/public_safety/flood/pdfs_word/riprap_guide.pdf

3.0 GENERAL CONSIDERATIONS

River / Estuary / Sea-case erosion is a result of interaction between the forces generated by river / tide / sea hydrodynamics and the soil or earth forming the bank line. These are elaborated in the following paragraphs which may have to be kept in mind by the engineer while conceptualizing a scheme for bank protection.

3.1 Flow Characteristics

The hydrodynamic loadings vary depending broadly upon the condition on whether the flow is:

- (a) Through a river unaffected by tide
- (b) Through a river that is tidal

Some other considerations are listed in the following paragraphs.

3.1.1 Bank curvature

For flow in rivers, the depth averaged velocity in the flow direction varies across the river width (in plan view) depending upon the curvature of the bank, as in meanders (Fig. 2).

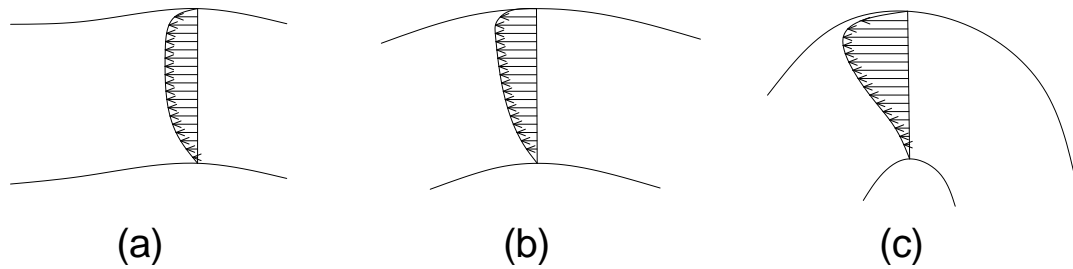

Fig.2: Plan view of depth-averaged velocity profiles in streams/rivers with (a) Low curvature; (b) Medium curvature, and (c) High curvature

Considerations on the velocity variation is important as, in the absence of field measurement of velocity, a suitable increased velocity needs to be adopted in the design of bank protection.

3.1.2 *Impinging flow*

Flow in river bends produces impinging flows in the upper layers of the flowing water (Fig. 3).



Fig. 3: Impinging flow in channel bends

3.1.3 *Secondaryflow*

Flow in river bends produces secondary flows (Fig. 4) which enhances the hydrodynamic loadings on the river bank.

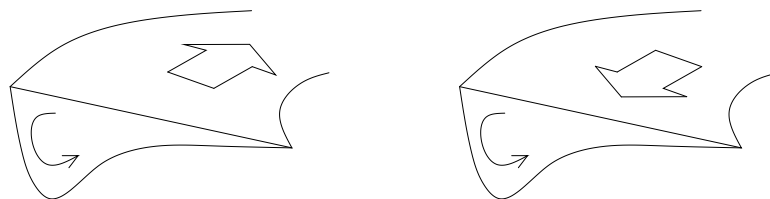

Fig. 4: Secondary flow in channel bends (the main flow direction may be in any direction)

3.1.4 *Rapid depletion of water stage*

In some rivers, the flow situation may be such that the water level may deplete rapidly from a high to a low stage within a relatively short period of time which may not permit release of the pore water pressure within the riverbank material. This may lead to failure of the bank.

3.1.5 *Overbank flow*

For some rivers, the high flood level may exceed the bank level (Fig. 5). In this case, the bank protection measure has to be carefully planned for flood discharges.

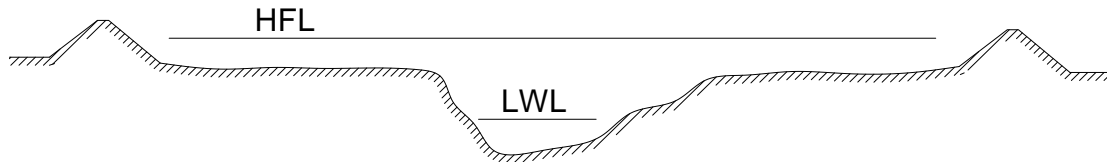

Fig. 5: High flood level (HFL) above riverbank that requires protection

3.1.6 *Waves due to wind*

For some rivers, the closeness to the sea sets up waves that impinge on the bank, causing further erosion.

3.1.7 *Waves due to navigation*

In some rivers, the passage of vessels generates additional waves that tend to erode the bank further, in addition to the hydrodynamic loadings.

3.1.8 *Sea waves*

These are the waves generated in the sea which impinge on the shorelines of estuaries and sea-faces.

3.1.9 *Other factors*

Human activities and animal grazing on the banks may aid in bank erosion.

3.2 *Geotechnical Characteristics*

Variations in earth/soil characteristics of the riverbank also influence the decision on the erosion protection measures. These geotechnical characteristics of the rivers of West Bengal, as indicated in Figure 1, are not always alluvial. On the other hand guidelines such as those given in IS: 14262 (Indian Standard on Planning and Design of Revetment) are developed for alluvial rivers (Reference: Section 1, IS: 14262). Of course, most of the protection works primarily meant for alluvial rivers may also be applied to other types of riverbank materials. Nevertheless, the following geotechnical considerations may be kept in mind while designing bank-protection works.

3.2.1 *Soil homogeneity*

While implementing bank protection measures, it is important to remember that the type of soil of the bank may be differ according to location. Bank soils may be classified as:

- Homogenous: * Alluvial material
 * Estuarine silt
- Non-homogenous: * Cay/silt soils
 * Layered soils clay/silt/sand

3.2.2 Bank failure mechanisms

Failure of unprotected banks has been widely studied and details are available in references like reference (d) mentioned in Section 2.0. Examples of different modes of geotechnical stream bank failure include the following:

- * Soil fall
- * Rotational slip
- * Slab failure
- * Cantilever failure
- * Pop-out failure
- * Piping
- * Dry granular flow
- * Wet earth flow, etc.

3.3 Scouring of riverbeds during floods

Scour of the riverbeds takes place during floods. Bend scour occurring towards the outer bank of a meandering river is of great concern to the designers of bank protection.

3.3.1 Scour formation in river bends

Bend scour, that is, the scour forming at a meander bend (Fig. 6a) is due to the impinging and secondary flow currents, as discussed in Section 3.2, apart from the shear stress generated by the longitudinal (stream-wise) flow velocity. Bend scour is greater than that occurs in a straight channel (Fig. 6b). Further, it is observed that the maximum depth of scour is greater during the passage of flood.

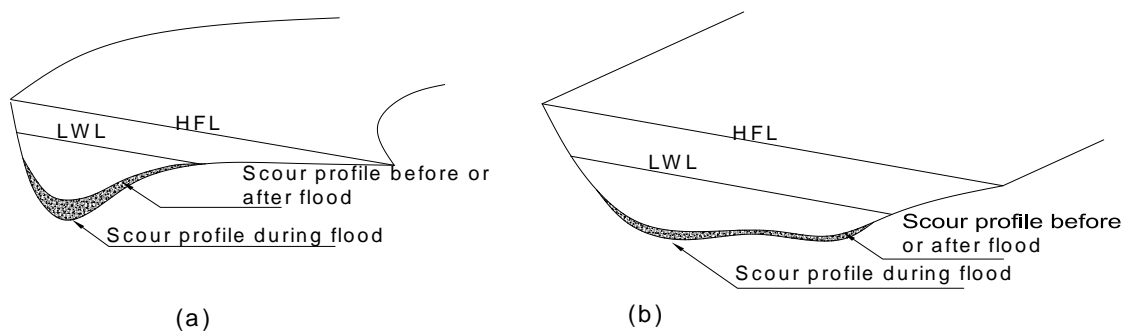

Fig. 6: Scour formation (a) At bend and (b) In straight reach

3.3.2 Depth of scour

IS: 14262 “Planning and design of revetment – Guideline” recommends the following for estimation of the maximum depth of scour (R, as per reference BIS 2013) at the bend:

$$R = 0.473 [Q/f]^{1/3} \text{ for waterway equal to or more than Lacey's waterway}$$

In case where the waterway is less than that recommended by Lacey's and also the flow is nonuniform, R is recommended to be calculated as:

$$R = 1.35 [q^2/f]^{1/3} \text{ and}$$

$$f = 1.76 d_{50}$$

where, R = Regime depth in m
 Q = design discharge in m³/s
 q = discharge per unit width in m³/s/m
 f = silt factor, and
 d₅₀ = mean particle diameter of river bedmaterial in mm

Maximum anticipated scour for launching apron has been recommended as = 1.5 R

Although the Lacey's regime equations are frequently used in India for finding the maximum scour depth and recommended in BIS codes, the following points may be considered while applying the same:

1. Lacey's regime equations are truly applicable for uniform flow
2. Scour depth in the bend may be higher than that predicted by Lacey's regime equations because of (a) Higher velocity, and consequently greater unit discharge, on the concave side of the bend, (b) Impinging flow in the bend, and (c) Secondary currents.

Hence, if the Lacey's regime equation is used for predicting maximum scour depth at bends, the increased velocity and unit discharges is required to be used. Or else, if Lacey's regime equation is used for predicting general scour for straight reach, a suitable multiplication factor has to be used. The data of the United States Army Corps of Engineers (USACE 1991) gives a graphical relation between bend scour and mean water depth in main channel (Figure 7). The graph is for sand-bed rivers, from which it may be observed that for rivers with large bend, the maximum depth of scour varies between 1.5 and 2.0 times mean water depth in approach channel. This may be seen to be slightly higher than that recommended in IS 14262 (recommended factor of multiplication with R being 1.5). The British Columbia manual on riprap design (Reference: BC 2000) also suggests a factor that may be computed as lying between 1.5 and 2.0 for rivers in bend.

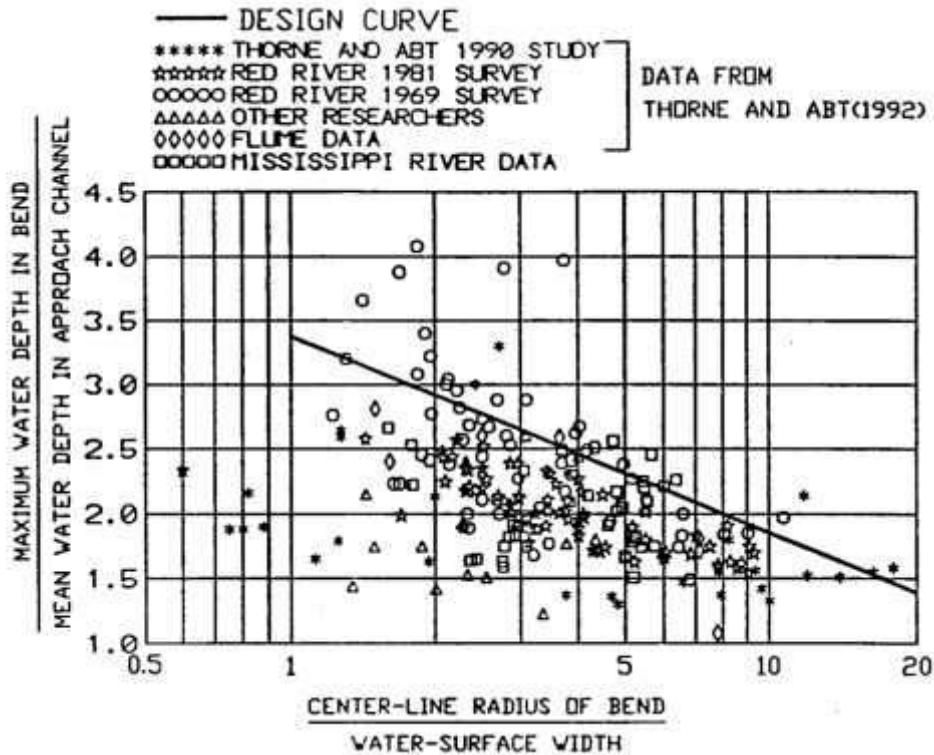

Fig. 7: Relation between maximum water depth in channel bend to the mean water depth in channel for sand bed rivers.

Design curves for scour in bends (Figure 7) are designated as safe design curves which represents upper limit for channels with irregular alignment.

3. It needs also be stated that a number of case studies and past experiences suggest that there has been wide variation between the scour depth calculated as per Lacey's formula and the depth of scour that has actually been taken place, in case of a few rivers, including Ganga-Padma.

4.0 BANK PROTECTION MEASURES

Bank protection measures are of different types. These may broadly be classified under:

I. Hard measures

- (a) Direct, as revetments/pitching/riprap, etc. which attempt to protect the bank directly from the erosive action of hydrodynamic loadings
- (b) Indirect, as spurs/groynes/vanes, etc. which attempt to divert the flow away from the affected reach of the river. It is advised that planning for such indirect measures should always be based upon experimental studies, either through physical models, or through mathematical (numerical) simulation models. Once done, the actual design may be adopted based upon the model observations.

II. Soft measures

These include protection of eroding bank by vegetative cover, mostly vetear plantation.

In this manual, only hard measures involving direct methods of bank protection have been discussed which are used or are being considered for application for the rivers of West Bengal.

4.1 *Revetment or pitching*

Revetment, a term in general use for bank and slope protection with stone pitching, is discussed in this section. Relevant guidelines and manuals are given under Section 2.0 References. These documents need to be referred to for detailed design of revetment protection of riverbanks against erosion. In the following sections, some of these and additional considerations are emphasized that need to be kept in mind for successful performance of revetment structures in the field.

4.1.1 *Stable slope for revetments*

It is generally recommended that a stable slope, not steeper than 2H:1V, is desirable for constructing revetment protection for an affected slope. Although a slope steeper than 2H:1V may perhaps be stable for a dry slope, additional shearing stresses created by the underwater currents in a river is likely to destabilize revetment materials (Fig. 8).

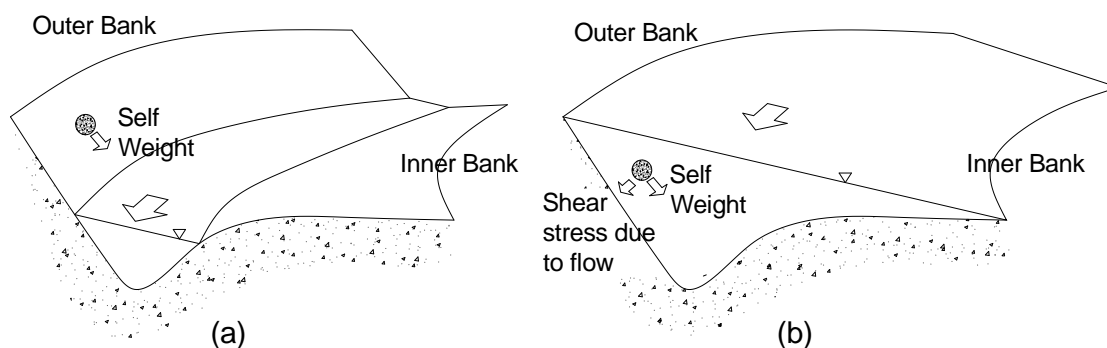

Fig. 8: An object that may be stable on dry slope as during low flows (a) may not be so under the additional shear stresses under submerged condition during floods (b)

Hence, the following guidelines may be observed for attaining a stable slope before placing the revetment material:

1. When sufficient land is available for setback

In this case, the land may be graded at least up to the low water level (LWL). Below LWL, the slope has to be made up by dumping suitable materials, like sand or earth filled gunny bags (Fig. 9).

2. When sufficient land is not available for setback

This case may arise when a building or some imp structure is present very close to the affected riverbank. In this case, both above and below LWL, the slope has to be made up by dumping suitable materials, like sand or earth filled gunny bags (Fig. 10).

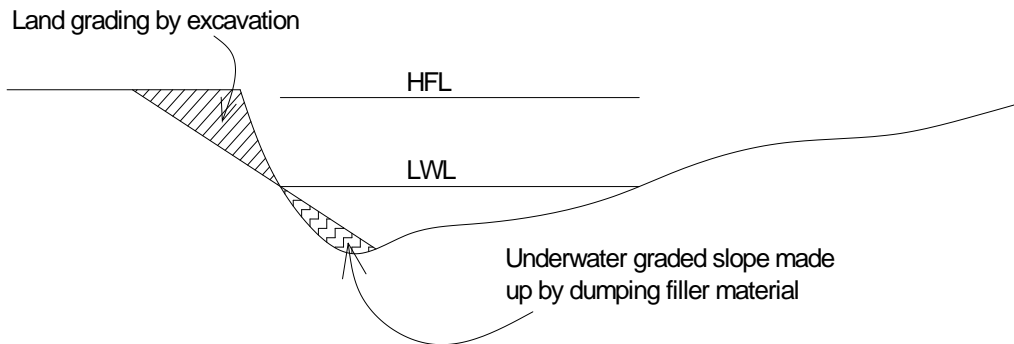

Fig. 9: Land grading when sufficient setback space is available

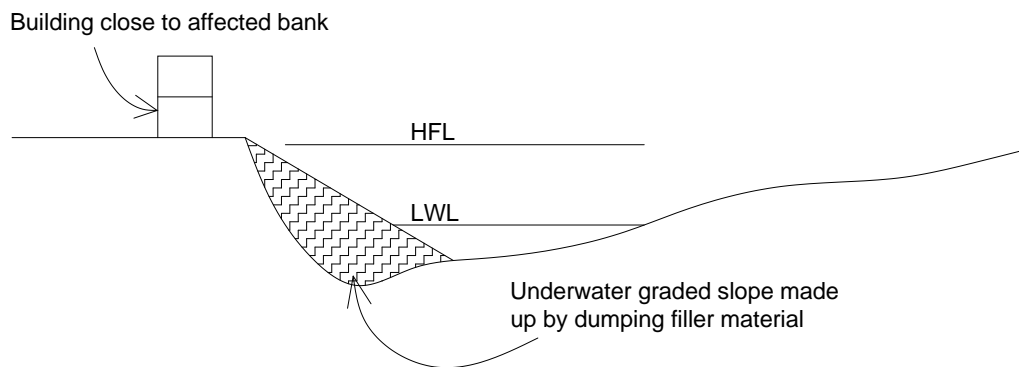

Fig. 10: Slope makeup by filling when sufficient setback space is not available

4.1.2 Provision of filter below revetments

The requirement of filters below revetments may arise under two situations, explained below.

1. One of the failure modes of revetment is because of piping caused by seepage pressure generated within the riverbank under rapid depletion condition of the water level in the river (Fig. 11a). In order to prevent this situation, which is likely to occur above the low water level (LWL), it is helpful to provide a layer of filter below the riprap (Fig. 11b).

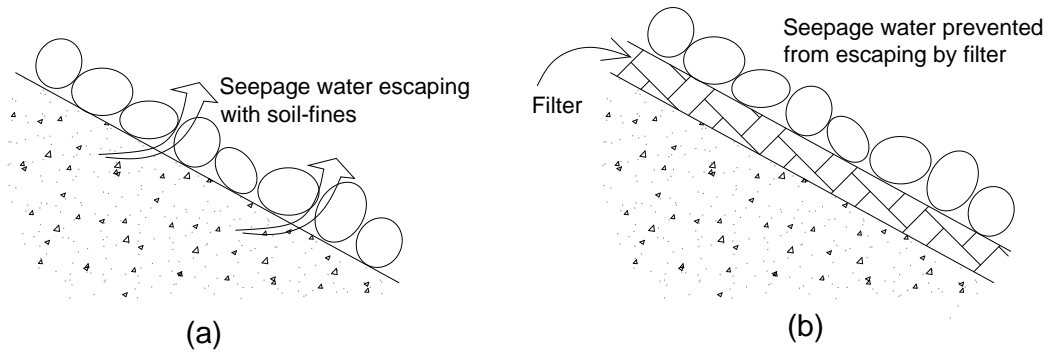

Fig. 11: Under rapid depletion of river water level, escaping seepage water may wash out soil fines, leading to piping failure (a), which may be prevented by a layer of filter (b)

2. Another reason for the failure of revetment is by the removal of fine riverbed particles from within the gaps of revetment boulders or blocks by suction action (Fig. 12a). This situation is more common during high flows, when the high underwater currents generated by impinging and secondary flows, generate turbulent vortices within the gaps. As a result, the revetment boulders or blocks tend to sink within the underlying riverbed. The revetment material can be made safe from this condition by providing an underlying filter (Fig. 12b).

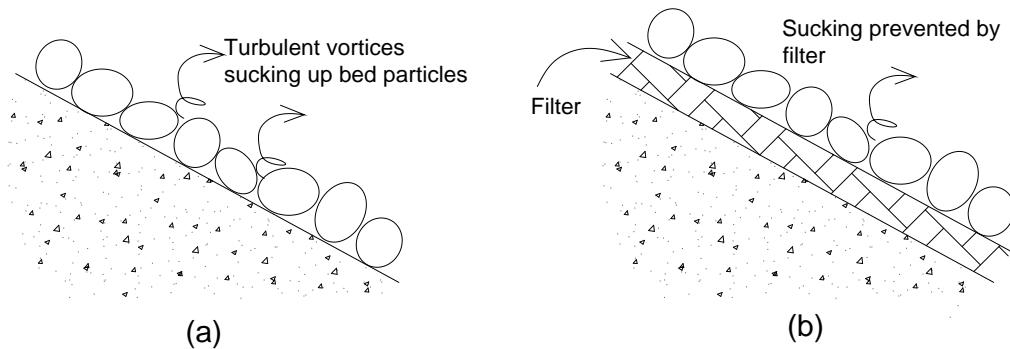

Fig. 12: Under flood flows, underwater currents may generate turbulent eddies within the gaps of revetment material, sucking out riverbed particles (a), which may be prevented by filter (b)

It is, therefore, recommended that a suitable filter be placed underlying the revetment, both above and below the low water level. However, since underwater placement of granular filters or geo-filters has been reported to be difficult in practice, it is recommended to place “Tarja-mats” or “Darma-mats” made up of good-quality bamboo-splicing for underwater filters. Typical placement of filters is shown in Fig. 13.

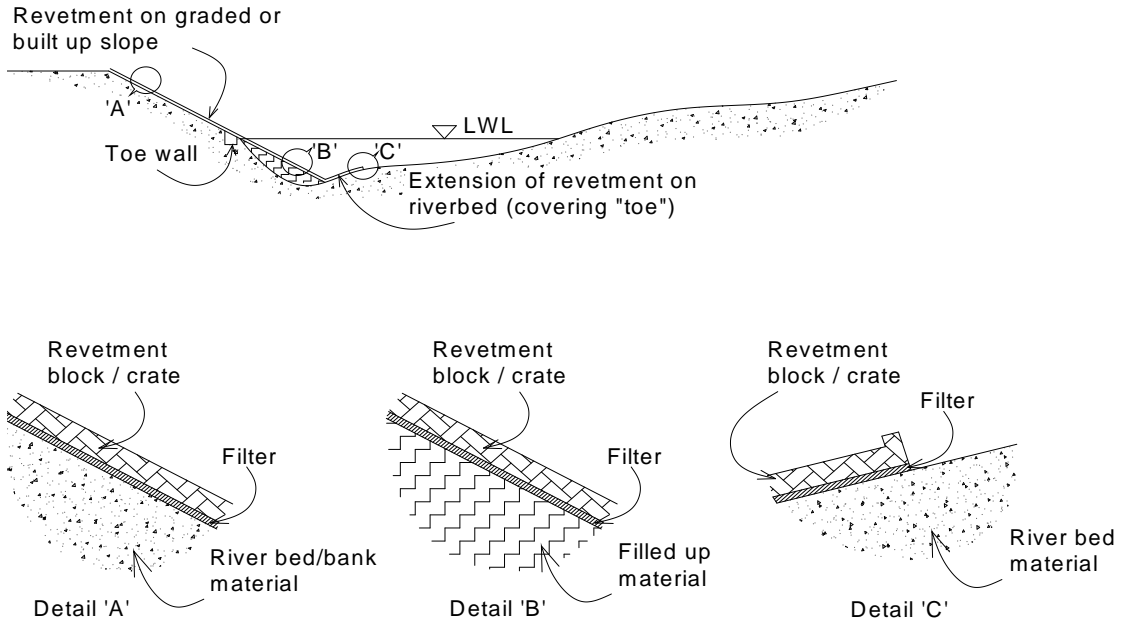

Fig. 13: Placement of filter on graded/built-up slope of riverbank and in the toe region

4.1.3 Extent of revetment below low water line

The requirement of providing revetment beyond the point where the graded slope meets the riverbed arises from the fact that high shear stresses occur at this location (Fig. 14a). The revetment extending beyond the “toe” launches with increasing scour during floods and helps to protect the rest of the revetment lying on the slope (Fig. 14b).

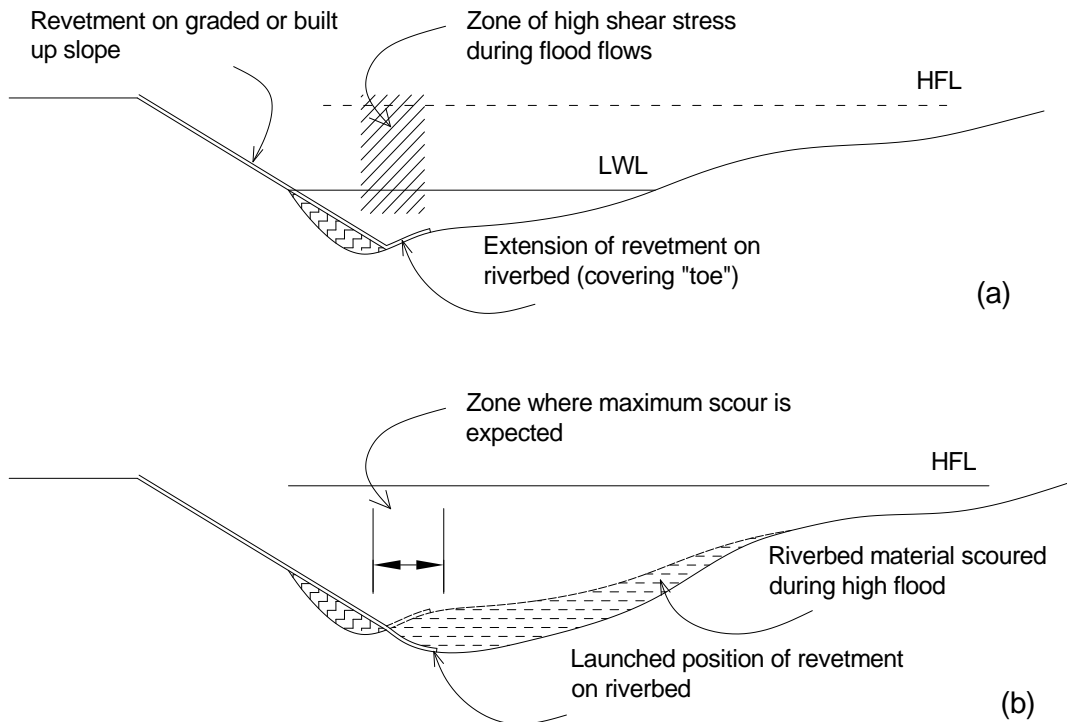

Fig. 14: (a) Revetment toe protection for countering zone of high shear stress; (b) Typical scour pattern during flood flows and protection of toe by the “launched” toe revetment

The length of a “launching apron” up to which the toe protection is recommended by the reference CWC (2012) as $1.5 D_s$, where D_s is the depth of scour measured below the low water level (Fig. 15). It is further recommended that the toe protection should extend at least some distance beyond the filled up riverbank below low water level.

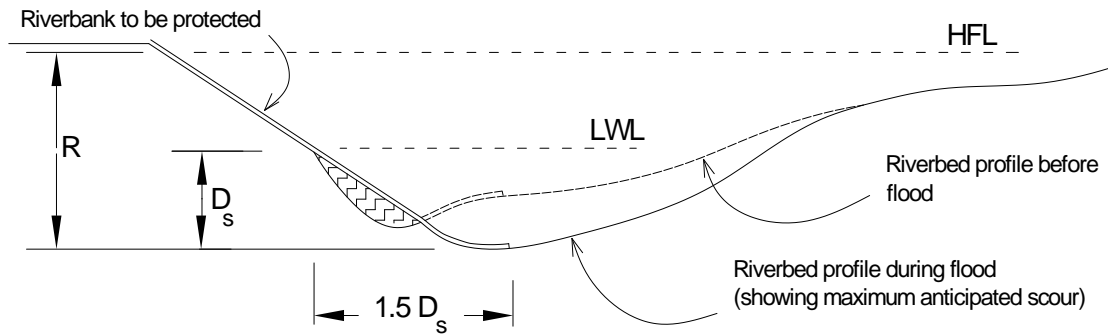

Figure 15: Recommended extent of revetment below low water line

The thickness of the revetment, T (in m) according to reference BIS (1995) is given as:

$$T = \frac{V^2}{2g(S_s - 1)}$$

In the above equation, V is the velocity (m/s), g is the acceleration due to gravity (m/s^2), and S_s is the specific gravity (relative density) of the stones used for the revetment.

It may be emphasized that the velocity near the toe of the revetment is rather high, as noted in Section 3.0 and also shown as high shear zone in Figure 14a. In the absence of observed velocity at the bend, a suitable incremented velocity may be used for determining the thickness of the revetment.

As for the launching apron, reference CWC (2012) has adopted a thickness of $1.5 T$, where T is the thickness of the revetment as found out above.

4.1.4 Application of crated stones/crated sand bags

For greater stability of the revetment near the toe (against the high shear stresses expected in this zone, Fig. 14a), it is recommended that instead of placing individual revetment material, like sand-filled gunny bags (or stones, or any other material being used), which are likely to get washed away by the underwater currents at this location, it would be safer to place crated bags, etc. (Fig. 16).

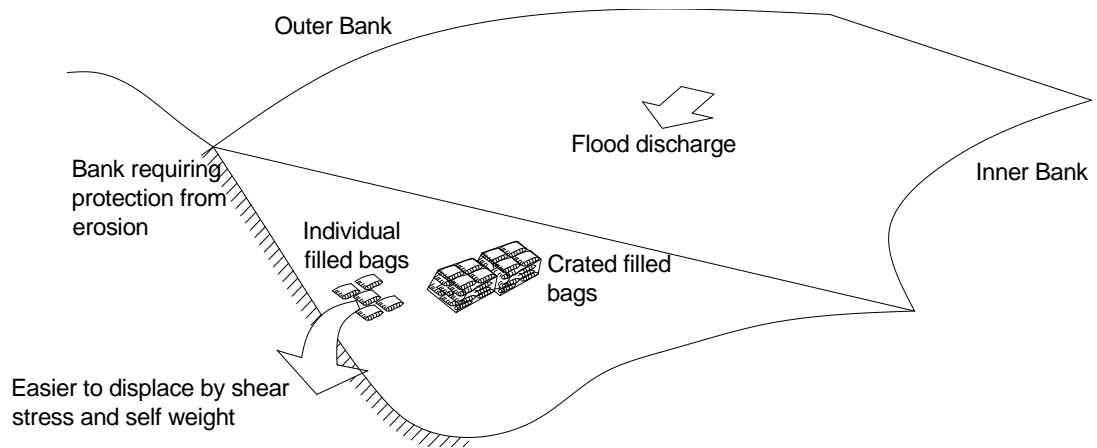

Fig. 16: Use of crated bags/boulders versus individual placement for greater stability

4.1.5 *Limitation of the concept of launching apron and alternative measure,*

It has been observed in case of many rivers in West Bengal flowing through the alluvial plain, that, bank erosion has been induced due to either deep scour that has already taken place resulting in formation of bed slope in between 1:3 or steeper, or the bank slope, although flatter, (varying from 1:3 to 1:5 or even more) is exhibiting tendency of scour. In the former case, the observed scour depth is generally much more than the calculated scour depth. In the latter case, which has mostly been found in Ganga-Padma river system, successive years of observations revealed that scour having depth much more than the calculated depth, occurred suddenly, particularly in those zone, where the deepest bed level closer to the bank is at least 5 metre below the non-monsoon LWL. Concept of launching apron is inappropriate for both the cases. It has been established through the performance of reasonable number of bank protection schemes executed in the above two cases using various technical options, that providing a solid base by filling the portion between LWL to the deepest bed level, with crated polybags is the most effective and enduring option for securing the bank line. This solid base prevents further erosion of bank and has been found to invite siltation. The volume requirement has been found to vary from 75 cum per metre to 190 cum per metre, depending on the river morphology and other consideration, in case of Ganga-Padma and much less for Bhagirathi and other rivers. The solution is quite cost effective and even economical than the concept of launching apron, due to use of 2nd hand empty cement base and river sand which does not have any material cost.

4.1.6 *Requirement of shallow bed bars for revetment protection*

In order to counter the secondary flows near the toe of the inner bend, it is recommended that low-height bed-bars may be placed at certain interval along the bank (Fig. 17). This would also help in inducing sedimentation along the toe thus preventing toe scour.

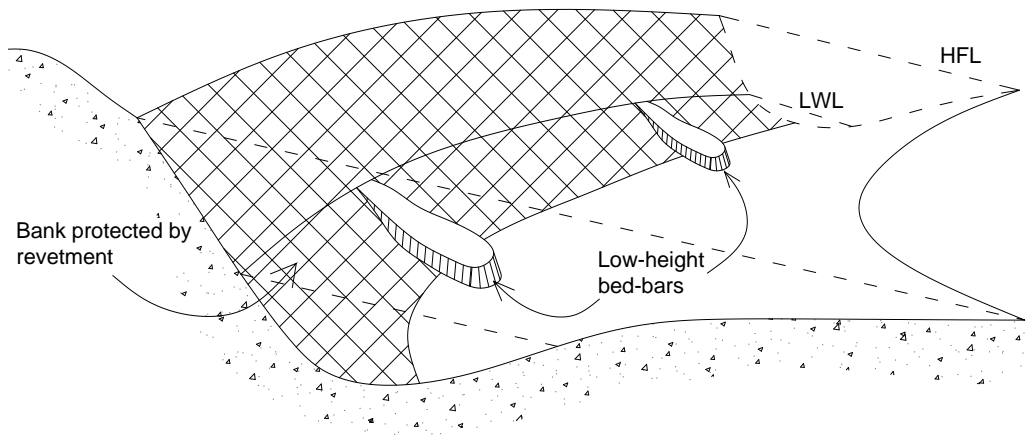

Fig. 17: Construction of low-height bed-bars along the toe of the protected zone

4.1.7 Longitudinal (upstream and downstream) extent of revetment

IS 14262 indicates (Fig. 7, BIS 1995 / BIS 2013) that there should be sufficient extension of the revetment protection both on the upstream and downstream directions along the riverbank. However, since there is no definite guideline provided in the aforesaid code or in CWC 2012, it is left to the judgment and discretion of the engineer in charge. It is presumed that the engineer will give due consideration to the upstream and downstream site conditions along the bank and decide upon the extension lengths.

Wherever the revetments are ended, it is recommended to have the revetment “keyed-in” into the banks for strengthening at the terminal edges of the revetments. WES (1997) suggests that the downstream keying should be given more attention as the trailing vortices here may cause bank failure just downstream of the riprap.

4.1.8 Arrangement of revetment at “toe”

The toe end of the revetment apron, as discussed in this manual, is of the launching apron type assuming that there is no hard stratum at or near the bed which may permit the construction of a key/sheet pile/toe-wall. The far end of the launching apron (recommended to be composed of crated filled-bags/boulders) towards the river centre-line may be strengthened with an additional layer of crated bags/boulders. Since the filter recommended is of the fascine mattress type, made up of bamboo-splicing mats (tarja/darma mats), it may not be possible to wrap these to the toe end revetment.

4.1.9 Arrangement of revetment at top end (bank line)

The revetment should extend in the vertical direction up to the design high water elevation plus some allowance for freeboard. The design high water may be fixed considering factors like wave action, which may be due to wind or boat traffic.

On many occasions, it is observed that the high flood level crosses the riverbank as the flow takes place over the flood plains. In such cases, the rising and receding flood flows may endanger the top end of the revetment. USACE (1991) recommends a “horizontal collar” at the top end where the revetment meets the bank edge (Fig. 18).

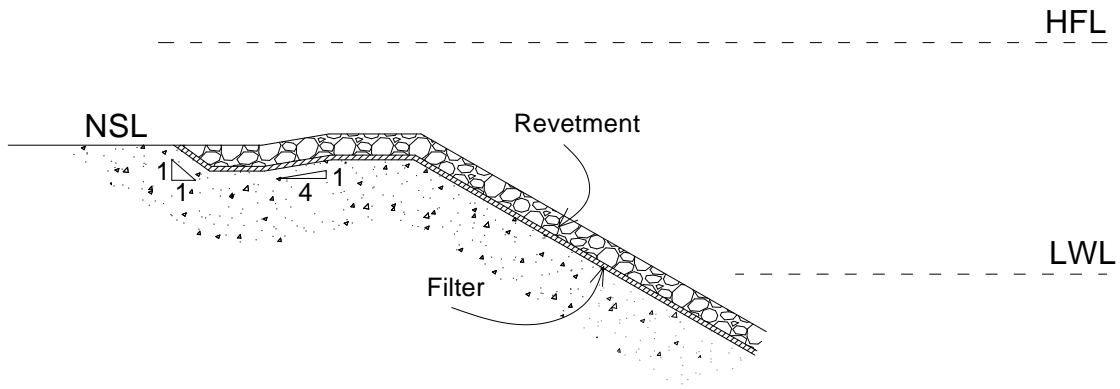

Fig. 18: Top end key-in for revetment in case of HFL far exceeding flood plain NSL

4.2 *Vegetal method of bank protection*

CWC (2012) recommends that for the cases of bank erosion, when the current is not too strong, the engineer in charge may consider using the application of protecting the bank with a vegetation cover. The “Vetiver” grass is being applied nowadays in several cases of bank erosion prevention, especially in South-East Asia. Also, there are instances of its successful implementation in Assam and Bangladesh.

Though a cost effective method, and one which is environment friendly, care must be taken for choosing the right kind of Vetiver that would survive the particular condition of the proposed site.

5.0 **RECOMMENDATIONS**

Selection of an appropriate river bank protection works depends on various factors, viz. hydro-morphological conditions of river, type of bank material, velocity of flow and discharge, availability of materials etc. It has been noticed that available BIS Code, CWC Guidelines, IRC Publications etc. do not always provide general guidelines and do not always address the case specific requirements. Moreover, effect of tide and consequent wave run up has not been considered by any standard. Irrigation & waterways Department has developed a data base on different types of bank protective works adopted in various rivers in different districts, based on the experience of last nine decades. Accordingly, recommendations on proposed bank protective works have been made zone-wise in the entire State, following a judicious consultation of prevailing Codes/Standards and on the basis of good engineering practices relying upon practical experience of both sustainability and failure. These recommendations, herein after called guidelines, have been detailed in the following chapters.

It is, therefore, recommended that all future bank erosion measures may comply with the provisions given in the guidelines. **However, guidelines, although region and river specific, may not always provide readymade solution to problems of unique nature, which may be worked out separately in consultation with Central Design Office(CDO), Irrigation & Waterways Department(I&WD).** It may further be

stated here that use of conventional materials for bank protection, i.e. boulder, cement concrete block, empty cement poly bags etc. have mostly been considered in the guidelines. Officers of the Irrigation & Waterways Department are also encouraged to embrace new technological development and to explore the options of using other materials mostly, polypropylene (PP) Geobags, or High Density Poly Ethelene (HDPE), sand bags conforming to BIS or other International Standard concrete tetrapods etc., subject to proven track record of economy, durability and suitability of application under different condition of exposure.

Original guidelines that were issued about one and half year back, has been successfully adopted and implemented in the field. Case studies and feedback received from the field level officials, however, pointed towards a few minor modifications as well as introduction of new concepts that have been piloted successfully. Committee Members deliberated the relevant issues in a special meeting held on 12th November 2019. The modified guidelines have accordingly been recommended by the Committee for future use with immediate effect. **Any clarification to this guideline, if required may be obtained from CDO, I&WD.**

6.0 These Modified Guidelines, proposed by Technical Expert Committee, for bank/bed protection of river /sea-face, are recommended for adoption in all works under Irrigation & Waterways Department, Government of West Bengal with immediate effect, except for special cases requiring special designs to suit the site specific requirements.

6.1 Zone A: North Bengal Districts

District covered: Darjeeling, Jalpaiguri, Alipurduar & Coochbehar

Sub Zone A-1: Boulder or boulder mixed with shingles zone near foothills with silt factor more than 3.50.

Bank Protection: Type-I (where height of bank top from river bed is less than 5.0 meter).

Description: Boulder sausage matressing as pitching and boulder in sausage as apron with boulder sausage deflectors as per Fig 1 with dimension as per Table-1.

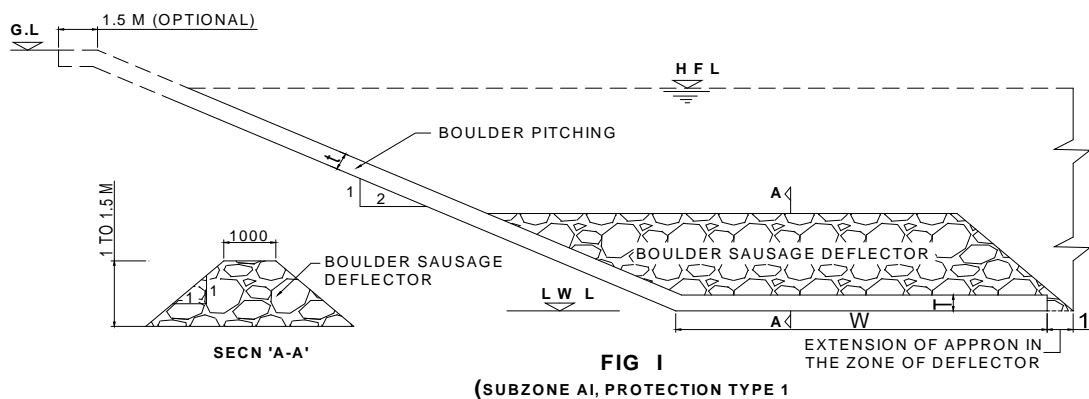

Table – 1.0

Discharge	Type of pitching	Thickness of pitching t(m)	Type of apron	Thickness of apron, T(m)	Length of apron, W(m)	Remarks
<2500 cumec	Boulder (N.B variety), sausage, matresing	0.45	Boulder sausage apron	0.60	$1.5 \times [1.5R^* - (HFL - LWL)]$	See Note below
>2500 cumec	- do -	0.60	- do -	0.90	- do -	- do -

*R = Normal scour depth below HFL

Details of boulder sausage deflector (for all discharge) :

Trapezoidal boulder sausage deflector, maximum height of 1.50 metre, top width generally 1.0 metre with side slope 1:1, to be laid at a spacing of $2.5 \times W$ (W being the length of apron, apron length being extended by 1.0 metre at the location of deflector to accommodate tapering transition).

Note: Pitching should be extended on bank top and continued for at least 1.50 metre in case HFL is above bank top and consequent spilling of bank takes place. Minimum thickness and weight of boulder are to be decided on the basis of site condition as well as availability.

I. Rationale of selection of bank protection in Sub-Zone A-1 (Type-1)

(Ref: Figure-1, Table-1.0)

1. Weight of stone/boulder/crated boulder

Modified version of IS: 14262 - 1995 recommends, Ishbash Formula as stated below, Ref.Cl. 3.3, P-1 of this Standard,

$$W = \frac{0.02323}{K} \times \frac{S_g}{(S_g - 1)^3} V^6 \quad \text{and} \quad K = \sqrt{1 - \frac{\sin^2 \theta}{\sin^2 \phi}}$$

where, W = Weight of individual stone/boulder in kg
 S_g = Specific gravity of boulder, for this case, 2.65
V = Velocity flow, in this zone, is generally above 3.50 metre/sec
 θ = Angle of bank slope with horizontal = 26.57 degree [2(H):1(V)]
 ϕ = Angle of repose of material of protection work = 27.0 degree

Substituting these values, K = 0.171 and W = 147.32 kg

Boulders are provided in crates, so minimum weight is guaranteed.

2. Size of boulder

Diameter (D_s) of boulder (or average size of crated boulder), as given in Cl. 3.3 and 3.4, P-1 of IS: 14262 -1995 is as below:

$$D_s = 0.124 \sqrt[3]{\frac{W}{S_g}} \quad D_s = 0.47 \text{ metre}$$

3. Thickness of apron

IS: 14262 - 1995 (Cl. 3.5, P-2) recommends two layers of boulders of dia D_s in sausage mattress for pitching. Thus the thickness (t) of pitching may be estimated as:

$$t = 2 * D_s \quad \dots \quad \dots \quad \text{(i)}$$

The following formula is given in Cl. 3.5 of IS: 14262 - 1995 for the boulders of the pitching to withstand negative pressure created by velocity:

$$t = \frac{V^2}{2g(S_g - 1)} \quad \dots \quad \dots \quad \text{(ii)}$$

Here, 't' is thickness of pitching in metre, V, S_g defined earlier.

Pitching thickness, 't', may be evaluated from Equation (i) or (ii) but from practical considerations, the minimum value of 't' is proposed as 0.45 metre for rivers with design discharge <2500 cumec and 0.60 metre for discharge > 2500 cumec.

Thickness of apron pitching, T, in the bed as recommended in Central Water Commission guidelines is given as T = 1.5 t.

4. Length of apron

Central Water Commission guidelines recommend that the length of the apron in the bed should be $1.5 * [1.5 * R - (HFL - \text{Bed Level at LWL})]$.

6.1.1 Sub-zone A-1

Bank Protection: Type-2 ((height of bank top from riverbed is more than 5.0 metre and bank is steep).

In Subzone A-1, the river bed is composed of boulders (medium or small) mixed with shingles, near the foothills, with silt factor more than 3.50.

In such beds, Lacey's scour depth formula is not applicable, which is only valid for alluvial river beds.

To obtain scour depth in (small) boulder river beds, the formula given by P.Sen (“Depth of scour in gravelly and boulder beds”, Journal of the Institute of Engineers (India), Vol. 77, 1997, P-209 to P-214) may be used. According to this formula the depth of scour from HFL (R) may be computed as:

$$R = \frac{0.2q^{0.855}}{d_{50}^{0.3}}$$

The above formula is applicable for discharges >500 cumec. For smaller discharges, the following formula shall be used:

$$R = 0.22 Q^{0.37} d_{50}^{-0.11}$$

[Limits: Q between 5m³/sec and 500 m³/sec, Bed slope between 0.02 and 0.0015]

(Ref. Formula developed by R.D. Hey, Journal of Hyd. Div. ASCE Proceedings Vol.112, 1986,Page 682).

The apron length can then be computed as,

$$W_A = 1.5D = 1.5*[1.5*R - (HFL - Bed Level at LWL)]$$

The details of the protection work with deflectors as per Fig. 2 on the riverside may be provided as detailed in Section A-A, for all cases other than stable parallel flow.

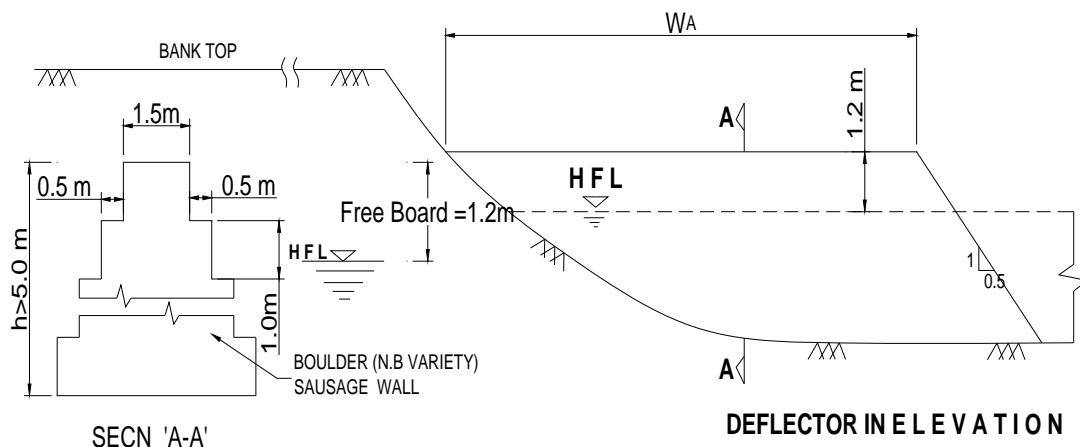

Fig. 2 (Sub-Zone A-1 (Type-2))

Deflectors are to be trapezoidal (as shown in Fig. 2) with boulder sausage. Maximum height of such deflectors shall be such that the top level of deflectors are 1.20 metre above the HFL. Top width of deflector is 1.50 metre with side slope of 1:1. Spacing of deflectors shall be 2.5W_A.

6.1.2 **Sub-zone A-2** Mature zone of rivers, far away from the foothills, nearing plain land/plateau, silt factor less than 3.5.

Bank Protection: Type-3

Description: Loose boulder single layer with bitumen grouting/multiple layers without bitumen grouting above shingle filter and loose boulder apron with or without boulder sausage deflectors, as per Fig. 3 with dimension as per Table 2.0.

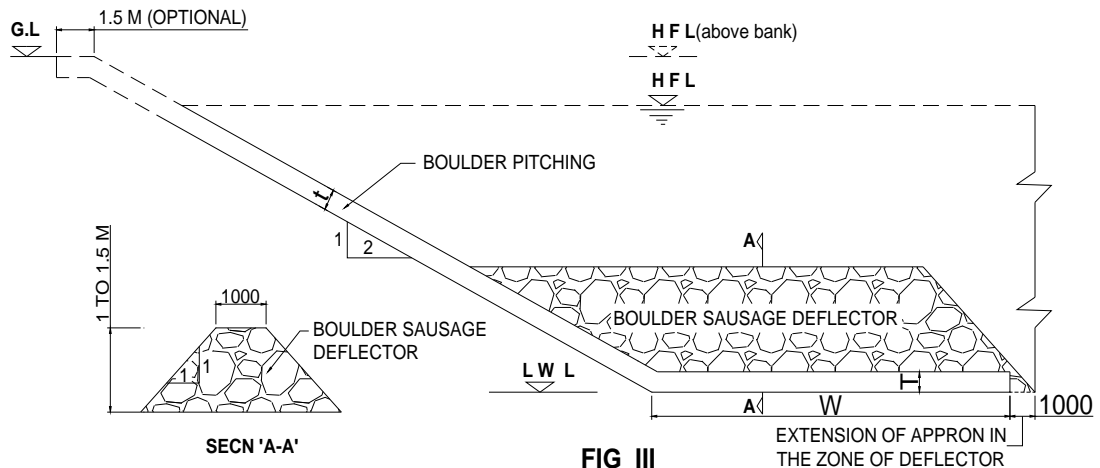

FIG III
(SUBZONE AII, PROTECTION TYPE 3)

Table – 2.0

Discharge	Type of pitching	Thickness of pitching t(m)	Type of apron	Thickness of apron, T(m)	Length of apron, W(m)	Remarks
<2500 cumec	Single layer boulder (NB variety), with bitumen grouting to fill up voids	0.23	Loose boulder (NB variety) apron	0.46	$1.5 \times [1.5R^{**} - (HFL - LWL)]$	See Notes below
>2500 cumec but less than 4500 cumec	Boulder (NB variety) pitching over 0.10 m thick shingles filter, interstices and voids to be filled and packed by small boulder or shingles.	0.38	- do -	0.60	- do -	- do -
> 4500 cumec	Boulder (NB variety) pitching over 0.15 m thick shingle filter, interstices/void between boulders to be filled & packed by small boulder/shingles.	0.45	- do -	0.90	- do -	- do -

**R = Normal scour depth below HFL (As per Lacey's formula)

Details of boulder sausage deflector:

To be used only in eroding zone in meandering rivers as per details provided in Table 1.0 and also in conformity to the section shown Section A-II above.

- Note:**
1. Pitching should be extended on bank top and continued for at least 1.50 metre in case H.F.L is above bank/embankment crest level.
 2. Minimum weight of boulder is to be decided on the basis of site condition as well as availability.
 3. Bank protection works may as well be used for embankment protection.
 4. To consider silt factor “f” as recommended by R.R.I, West Bengal, while computing the scour depth / length of apron.

II. Rationale of selection of bank protection in Sub-Zone A.II

To find out the minimum weight of stone/boulder to be used in bank protection, ref Cl. 3.3, Page-1 of IS: 14262 -1995, following expression shall be used like earlier.

$$W = \frac{0.02323}{K} \times \frac{S_g}{(S_g - 1)^3} V^6 \quad \text{and} \quad K = \sqrt{1 - \frac{\sin^2 \theta}{\sin^2 \phi}}$$

- where, W = Weight of individual stone/boulder in kg
 S_g = Specific gravity of boulder, for this case, 2.65
V = Velocity flow, in this zone, is generally above 2.50 metre/sec
 θ = Angle of bank slope with horizontal = 26.57 degree [2(H):1(V)]
 ϕ = Angle of repose of material of protection work = 27.0 degree

Substituting these values, K = 0.171 and W = 19.57 kg

Minimum weight of boulder for protection is generally = 30.0 kg or more

After having the weight of individual stone, size (D_s) of same shall be given vide Cl. 3.4, Page-1 of IS: 14262 -1995, from sliding consideration,

$$D_s = 0.124 \sqrt[3]{\frac{W}{S_g}} \quad D_s = 0.28 \text{ metre}$$

Thickness (t) of protective layer, pitching or launching apron, vide Cl. 3.5, Page-2 of IS: 14262 - 1995, may be defined as follows:

$$t = \frac{V^2}{2g(S_g - 1)} \quad t = 0.19 \text{ metre}$$

Here, ‘t’ is thickness of pitching in metre, V, S_g defined earlier.

For safety two layers of stone as per ‘ D_s ’, i.e. t = 2 x 0.28 m, or 0.56 metre are to be provided as per IS:14262 - 1995.

As per IRC:89-1997, thickness is governed by total discharge (Q), that is,

$$t = 0.06Q^{\frac{1}{3}}$$

where, 't' is the thickness of pitching & 'Q' is the design discharge through channel/river for discharge = 2500 cumec and t = 0.81 metre.

So, there is a wide variation in above calculated thicknesses (two layers of 0.28 m to 0.81 metre). Based on practical experience and rationalization, thickness of pitching has been linked with sliding consideration, as shown in Table 3.0.

Thickness of boulder apron is generally kept at 1.50 times thickness of pitching, after suitable rounding off and rationalization subject to a minimum not less than 0.46 metre.

Length of apron W_A is recommended in CWC guideline as $1.5D$, where 'D' is the depth of scour below LWL = $1.5R - (HFL - LWL)$.

If the river bed is alluvial, Lacey's scour depth equation may be used for calculating 'R'.

To obtain scour depth in (small) boulder riverbeds, the formula given by P.Sen ("Depth of scour in gravelly and boulder beds", Journal of the Institute of Engineers (India), Vol. 77, 1997, Page 209 to 214) may be used. According to this formula the depth of scour from HFL (R) may be computed as:

$$R = \frac{0.2q^{0.855}}{d_{50}^{0.3}}$$

d_{50} between 0.2m and 0.04 m, Bed slope between 0.005 and 0.0008.

[Limits: Q between $5\text{m}^3/\text{sec}$ and $500\text{m}^3/\text{sec}$, Bed slope between 0.02 and 0.0015]

(Ref. Formula developed by R.D. Hey, Journal of Hyd. Div. ASCE Proceedings, Vol.112, 1986,Page 682).

The apron length can then be computed as,

$$W_A = 1.5D = 1.5*[1.5*R - (HFL - \text{Bed Level at LWL})]$$

6.2 Zone B: North Central, Central, Western and Eastern Districts in Non-tidal Zone

District covered: Uttar & Dakshin Dinajpur, Malda, Murshidabad, Nadia, Birbhum, Bankura, Burdwan and non-tidal area of Hooghly, Howrah & Paschim Medinipur.

Sub Zone B-1: Ganga-Padma, Bhagirathi and Fulahar River in Malda, Murshidabad & Nadia.

Bank Protection: Type 4B-I/1 (Considerable erosion between LWL & HFL but bank slope is flatter than 1(V):3(H) and calculated scour depth is more than the scour depth observed after passage of flood multiplied by 1.25, for all rivers other than Ganga-Padma and such calculated scour depth is equal to or more than four times of the observed scour depth in case of Ganga-Padma. **In case of non-fulfillment of any of the two conditions for rivers other than Ganga-Padma, protection Type 4B-1/2 should be adopted.**

Sub Category 4B-I/1/1, where there is sufficient space on bank top to set back as per Fig.4B-I/1/1 with dimension as per Table 3.0.

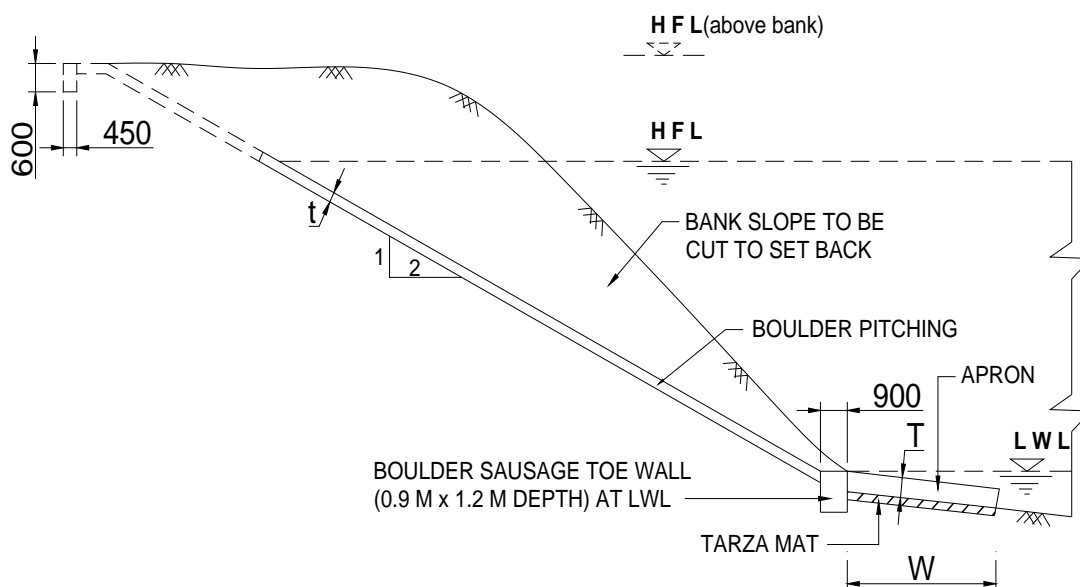

Fig.4B-I/1/1(Sub Zone BI, Protection Type 4B-I/1, Sub-category 4B-I/1/1)

Table – 3.0

River	Type of pitching	Thick-ness of pitching t(m)	Type of apron	Thick-ness of apron, T(m)	Length of apron, W(m)	Remarks
Ganga–Padma	Double layer stone boulder pitching over geojute/geosynthetic filter (woven type) conforming to specification laid down.	0.46	Boulder sausage apron of 1m x 1m over layer of Torza Mat	0.60	$1.5 \times [1.5R - (HFL - LWL)]$	See Notes below
Bhagirathi	Single layer stone boulder pitching over bitumen treated geojute/geosynthetic filter (woven type) conforming to specification laid down.	0.23	Loose boulder apron over a layer of Tarja Mat	0.46	– do –	– do –

R = Normal scour depth below HFL

- Note:**
1. Pitching should be extended on bank top and continued for at least 1.50 m with a key at the end if HFL is above bank top.
 2. Minimum weight of boulder is to be considered on the basis of site condition as well as availability.

3. Consider silt factor “f” as recommended by R.R.I, West Bengal.
4. Apron should be laid along slope, so that top upper corner of the apron remains more or less flushed with the L.W.L. prevailing during execution.
5. Problem of erosion in river Fulahar needs to be dealt separately, in consultation with the Central Design Office, Irrigation & Waterways Directorate.

6.2.1 Sub-Zone B I

Bank Protection: Type 4B-I/1

Description: Sub category 4B-I/1/2, when there is practically no scope to set back, protection should be as per Fig.4B-I/1/2 with dimensions in Table 4.0.

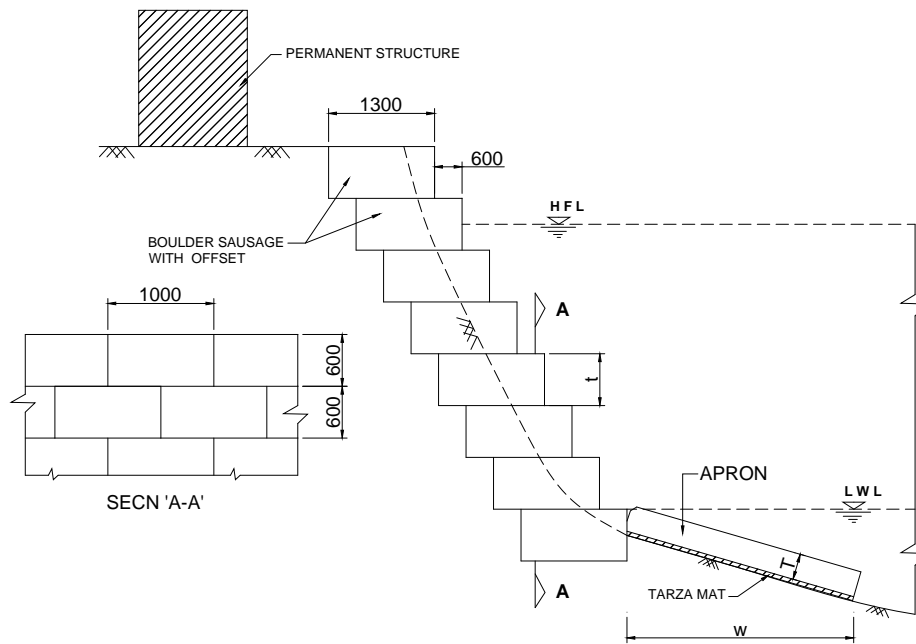

Fig.4B-I/1/2 (Sub Zone BI, Protection Type 4B-I/1, Sub-category 4B-I/1/2)

Table – 4.0

River	Type of pitching	Thick-ness of pitching t(m)	Type of apron	Thick-ness of apron, T(m)	Length of apron, W(m)	Remarks
Ganga–Padma	Boulder sausage of 1.3 m wide x 0.6 m height x 1.0 m long, to be put one after another with offset of 0.60 m across the flow and in a staggered fashion along the flow.	0.60	Boulder sausage apron of 1m x 1m over layer of Torza Mat	0.60	1.5 x [1.5R – (HFL–LWL)]	See Notes below
Bhagirathi	Single layer stone boulder pitching over bitumen free geojute/geosynthetic filter (woven type) conforming to specification laid down.	0.60	Loose boulder apron over a layer of Tarja Mat	0.46	1.5 x [1.5R – (HFL–LWL)]	See Notes below

R = Normal scour depth below HFL

- Note:**
1. Length of the protection in this manner should not be continued for more than 100 metre at a stretch.
 2. Minimum weight of boulder is to be considered on the basis of site condition as well as availability.
 3. Consider silt factor “f” as recommended by R.R.I, West Bengal.
 4. Apron should be laid along slope in the same manner as stated for Sub-category 4B-I/1/1.
 5. Problem of erosion in river Fulahar needs to be dealt separately, in consultation with the Central Design Office, Irrigation & Waterways Directorate.

Sub-Zone B I

Bank Protection: Type 4B-I/S(Special case for Ganga-Padma river system)

Description: Category 4B-I/S/1, is applicable when bank slope is flatter than 1(V):3(H), and observed scour depth is more than 1/4th of the calculated scour depth but such observed scour depth multiplied by 1.25 is less than the calculated scour depth, which is indicative of the situation that further scour is very much likely to occur.

1st sub-Category: 4B-I/S/1; When there is sufficient slope on bank top to set back, as per Fig 4B-I/S/1 with dimensions as per Table 4S/1.

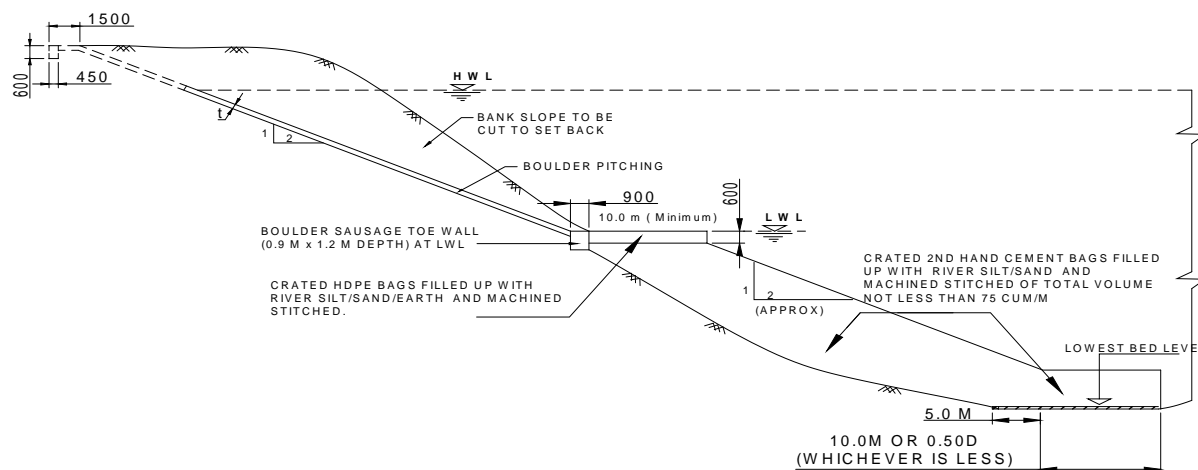

Fig 4B-I/S/1
(Sub Zone B1 Protection type 4B-I/S only Ganga, Padma river system)

Table – 4S/1

River	Type of pitching	Thick-ness of pitching t(m)	Type of filler material for scour hole	Width at berm / LWL, (m)	Width of extension of end protection B _B (m)	Thick-ness of Filler materials at end, T _A (m)	Remarks
Ganga–Padma	Double layer stone boulder pitching over bitumen treated geojute/geosynthetic filter (woven type) con-forming to speci-fication laid down.	0.46	Crated (Nylon/PP) sand bags/ similar poly-bags filled up with river silt/sand/earth & m/c stitched. (crate size 1mx1mx1m)	10.0 m (minim um)	10.0 m or 0.5 x D whichever is lesser	3.00	See Notes below

- Note:**
1. Pitching should be extended on bank top & continued for a length of 1.50 metre with a key at the end if HFL is above bank top level.
 2. Minimum weight of boulder is to be considered on the basis of site condition as well as availability.
 3. Consider silt factor “f” as recommended by R.R.I, West Bengal.

4. Length of Tarza Mat should be 5.0 metre + B_B at the lowest bed level, where bed level is more or less flat.
5. The initial work may be carried out upto the berm of crated bag at LWL and the boulder pitching work above LWL should be taken up at least after one monsoon season for stabilization purpose and HDPE sand bag pitching may be provided as interim measure before pitching work, if required. Also, arrangement should be made to maintain the filled up portion for such period. Therefore, estimates in such cases should be proposed separately for two phases. Phase I for filling up the portion below the LWL, berm formation, sausage toe wall and HDPE sand bag pitching and Phase II for boulder pitching on bank slope in replacement of HDPE sand bags, HDPE sand bags may be provided in two layers in nylon crates of nominal size 1 m. X 1 m X 0.4 m. Total number of bags in crate should not exceed 15 and approximately 15% of the bags may be partially filled to reduce the void within individual bags, so as to give a more compact shape of the crate. In case it is found after one year of observation that HDPE sand bags have more or less been stabilised with a layer of silt deposition at top of the bag along with indication of vegetative growth, such bag should not be disturbed and Phase II works need not be executed at all. In case it is decided to execute the Phase II work, the HDPE bags replace by boulder pitching should be around the lowest portion of the filled up scour holes.
6. ADCP survey is a must to assess the extent of the scour hole.

Rationale of selection: Since there is high probability of scour and launching apron may fail in that case, as experienced on past occasions, there is imminent need to provide sufficient filler materials at the base by a solid mass which could be done by crated (Nylon/PP) polybags (i.e. 2nd hand cement bags, machine stitched after filling with river sand/silt). Again for the purpose of ensuring stability in the event of scouring which is generally much higher than the calculated scour as per Lacey's formula in Ganga-Padma the filler should have a volume of 75 cum per metre run. Since polybags exposed to wetting & drying may fast disintegrate, those would be covered at the berm level by HDPE bags. Use of Tarza mat at end location of the filling, when bed slope is more or less flat is strongly recommended to avoid the tendency of local scour of bed material.

2nd Sub category 4B-I/S/2; When there is practically no space to set back, protection should be as per Fig. 4B-I/S/2 with dimensions as per Table 4S/2.

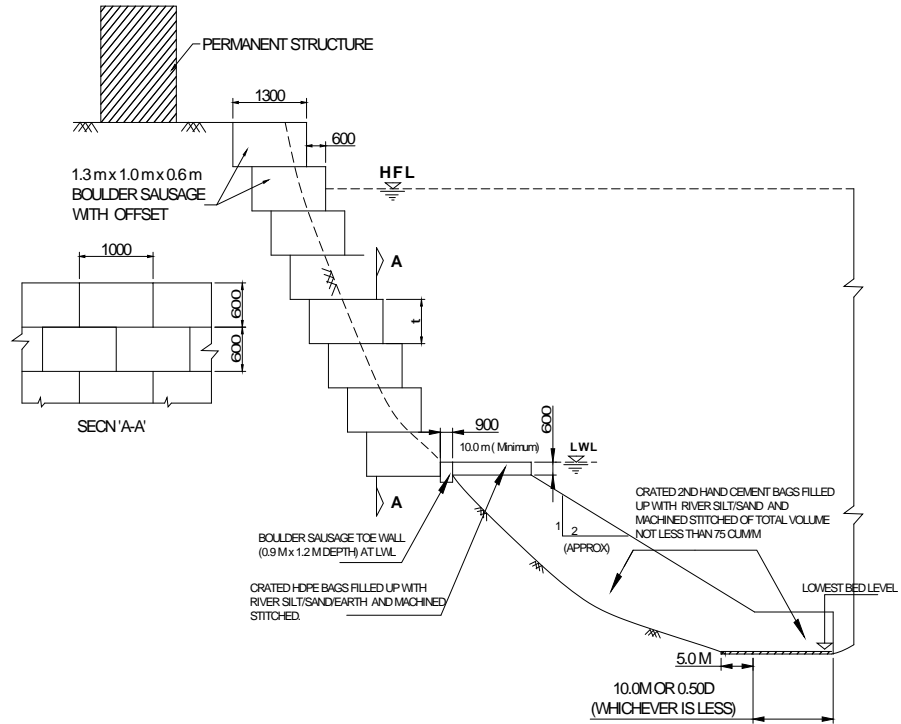

Fig 4B-I/S/2
(Sub Zone Protection type only Ganga, Padma river system)

Table 4S/2.

River	Type of pitching	Thick-ness of pitching t(m)	Type of filler material for scour hole	Width at berm / LWL, (m)	Width of extension of end protection B _B (m)	Thick-ness of Filler materials at end, T _A (m)	Remarks
Ganga–Padma	Double layer stone boulder pitching over bitumen treated geojute/geosynthetic filter (woven type) conforming to specification laid down.	0.46	Crated (Nylon/PP) sand bags/similar poly-bags filled up with river silt/sand/earth & m/c stitched. (crate size 1mx1mx1m)	10.0 m (minimum)	10.0 m or 0.5 x D whichever is lesser	3.00	See Notes below

$D = \text{Anticipated scour depth below LWL} = 1.5R - (\text{HFL} - \text{LWL})$, $R = \text{Normal scour depth below HFL}$

- Note:
1. Length of protection in this manner should not be continued for length more than 100 metre at a stretch.
 2. Minimum weight of boulder is to be considered on the basis of site condition as well as availability.
 3. Consider silt factor “f” as recommended by R.R.I, West Bengal.
 4. Length of Tarza Mat should be 5.0 metre + B_B at the lowest bed level, where bed level is more or less flat.
 5. ADCP survey is a must to assess the extent of the scour hole.

Sub-Zone B I

Bank Protection: Type 4B-I/2(Considerable erosion between LWL and HFL together with bed scour, resulting in steeper bank slope than 1(V):3(H) and calculated scour depth is less than scour depth observed after passage of flood multiplied by 1.25).

Description: Sub category 4B-I/2/1, when there is sufficient slope on bank top to set back, as per Fig 4B-I/2/1 with dimensions as per Table 5.0.

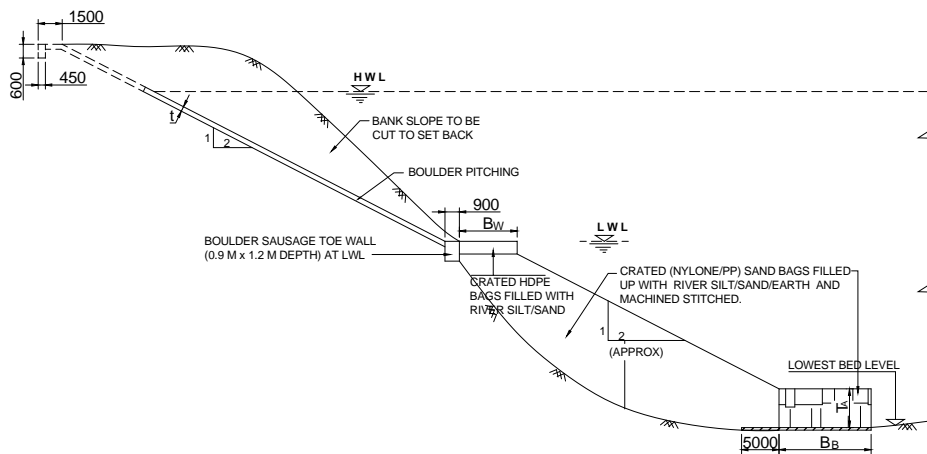

Fig. 4B/I (Sub Zone BI, Protection Type 4B-I/2, Sub-category 4B-I/2/1)

Table – 5.0

River	Type of pitching	Thick-ness of pitching t (m)	Type of filler material for scour hole	Width at berm / LWL, B _w (m),	Width of extension of protection B _B (m)	Thick-ness of Filler materials at end, T _A (m)	Remarks
Ganga–Padma	Double layer stone boulder pitching over bitumen treated geojute/geosynthetic filter (woven type) con-forming to speci-fication laid down.	0.46	Crated (Nylon /PP) sand bags/ similar poly-bags filled up with river silt/ sand/earth & m/c stitched. (crate size 1m x 1m x 1m)	6.00	10.0 m or 0.5 x D whichever is lesser	3.00	See Notes below
Bhagirathi	Single layer stone boulder pitching over bitumen treated geojute/geosynthetic filter (woven type) con-forming to speci-fication laid down.	0.23	– do –	3.00 /5.0 (where observed scour is more than the calculated /reverse condition)	3.0 m or 0.5 x D whichever is lesser	2.00	– do –

D = Anticipated scour depth below LWL = 1.5R-(HFL-LWL) ,R=Normal scour depth below HFL

Note: 1. Pitching should be extended on bank top & continued for a length of 1.50 metre with a key at the end if HFL is above bank top level.

2. Minimum weight of boulder is to be considered on the basis of site condition as well as availability.

3. Consider silt factor “f” as recommended by R.R.I, West Bengal.

4. Length of Tarza Mat should be 5.0 metre + B_B at the lowest bed level, where bed level is more or less flat.

5. In case of scour hole filling, the initial work may be carried out upto the berm of boulder crate at LWL and the boulder pitching work above LWL should be taken up at least after one monsoon season for stabilization purpose and HDPE sand bag pitching may be provided as interim measure before pitching work, if required. Also, arrangement should be made to maintain the filled up portion for such period. Therefore, estimates in such cases should be proposed separately for two phases. Phase I for filling up the portion below the LWL, berm formation, sausage toe wall and HDPE sand bag pitching and Phase II for boulder pitching on bank slope in replacement of HDPE sand bags, HDPE sand bags may be provided in two layers in nylon crates of nominal size 1 m. X 1 m

X0.4 m for Ganga-Padma and in single layer with 50% overlap for other rivers.. Total number of bags in crate should not exceed 15 and approximately 15% of the bags may be partially filled to reduce the void within individual bags, so as to give a more compact shape of the crate. In case it is found after one year of observation that HDPE sand bags have more or less been stabilised with a layer of silt deposition at top of the bag along with indication of vegetative growth, such bag should not be disturbed and Phase II works need not be executed at all. In case it is decided to execute the Phase II work, the HDPE bags replace by boulder pitching should be around the lowest portion of the filled up scour holes.

6. ADCP survey is a must to assess the extent of the scour hole.

7. Problem of erosion in river Fulahar needs to be dealt separately, in consultation with the Central Design Office, Irrigation & Waterways Directorate.

Rationale of selection: Since scour has already been taken up, there is no need of providing launching apron. The imminent need is to fill up the scour hole by a solid mass which could be done by crated (Nylon/PP) polybags (i.e. 2nd hand cement bags, machine stitched after filling with river sand/silt). Since polybags exposed to wetting & drying may fast disintegrate, those would be covered at the berm level by HDPE bags. Use of Tarza mat at end location of the filling, when bed slope is more or less flat is strongly recommended to avoid the tendency of local scour of bed material.

Sub category 4B/I/2/2, when there is practically no space to set back, protection should be as per Fig.4B-I/2/2 with dimensions as per Table 6.0).

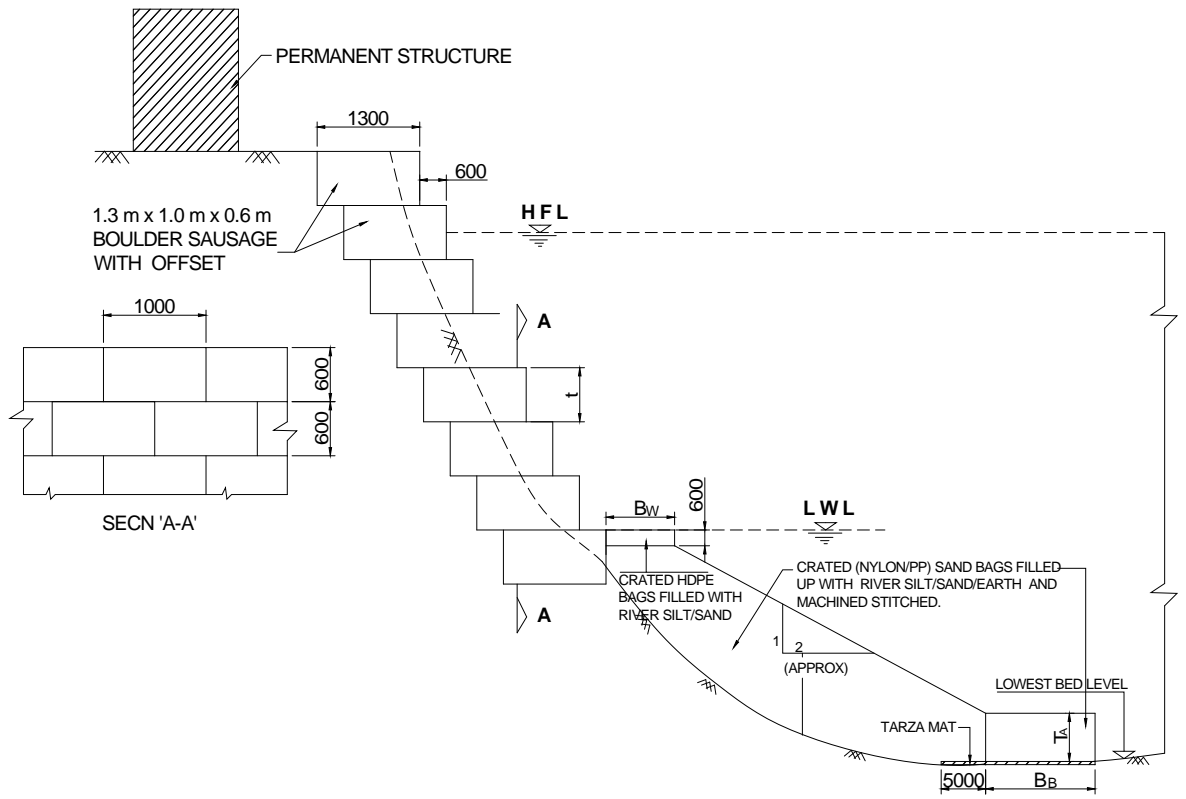

Fig. 4B/I/2/2 (Sub Zone BI, Protection Type 4B-I/2, Sub-category 4B-I/2/2)

Special Remark: Note 5 (Page 30) and Rational of selection (Page 31) corresponding to Sub category 4B-I/2/1 will also be applicable for this sub-category.

Table – 6.0

River	Type of pitching	Thick-ness of pitching t(m)	Type of filter material for scour hole	Width at berm / LWL, B _w (m), of apron, T(m)	Width of extension of protection B _B (m)	Thick-ness of Filter materials at end, T _A (m)	Remarks
Ganga–Padma	Boulder sausage of 1.3 m wide x 0.6 m height x 1.0 m long, to be put one after another with offset of 0.60 m across the flow and in a staggered fashion along the flow.	0.60	Crated (Nylon /PP) sand bags/ similar poly-bags filled up with river silt/ sand/earth & m/c stitched. (crate size 1mx1mx1m)	6.00	10.0 m or 0.5 x D whichever is lesser	3.00	See Notes below
Bhagirathi	Single layer stone boulder pitching over bitumen free geojute/geosynthetic filter (woven type) conforming to specification laid down.	0.60	– do –	3.0 /5.0 (where observed scour is more than the calculated /reverse condition)	3.0 m or 0.5 x D whichever is lesser	2.00	– do –

D = Anticipated scour depth below LWL = 1.5R-(HFL-LWL) , R=Normal scour depth below HFL

- Note:**
- Length of protection in this manner should not be continued for length more than 100 metre at a stretch.
 - Minimum weight of boulder is to be considered on the basis of site condition as well as availability.
 - Consider silt factor “f” as recommended by R.R.I, West Bengal.
 - Length of Tarza Mat should be 5.0 metre + B_B at the lowest bed level, where bed level is more or less flat.
 - ADCP survey is a must to assess the extent of the scour hole.
 - Problem of erosion in river Fulahar needs to be dealt separately, in consultation with the Central Design Office, Irrigation & Waterways Directorate.

6.2.2 Sub-zone BII All river other than Ganga-Padma, Bhagirathi & Fulahar in the district mentioned under Zone B.

Bank Protection: Type 4B-II/1

Description: Single layer loose boulder over a layer of filter with sausage toe wall and nominal boulder sausage apron as per Fig.4B-II/1 and dimensions as per Table 7.0.

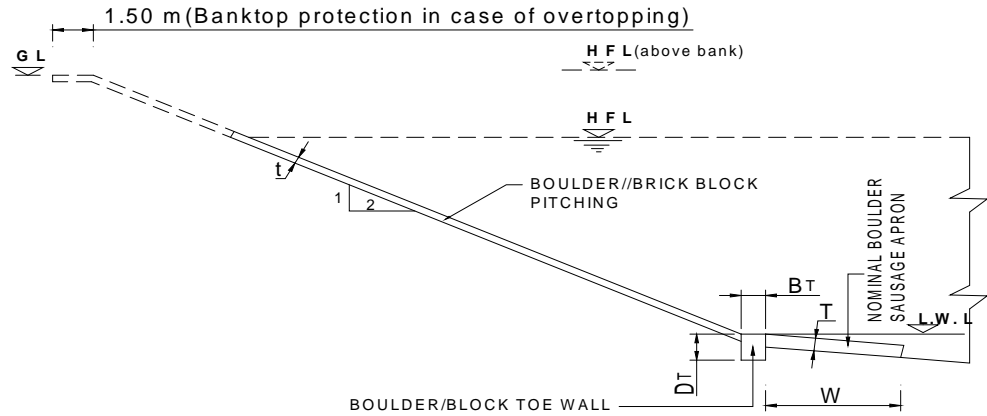

Fig.4B-II/1 (Type 4B-II/1)

Table – 7.0

River	Type of pitching	Thick-ness of pitching t(m)	Toe Wall		Type of apron	Thick-ness of apron T (m)	Length of apron W (m)	Remarks
			Width B_T (m)	Depth D_T (m)				
Mayurakshi, Ajoy, Damodar, Kangsabati, Subarnarekha	Single layer stone/ laterite boulder/brick block (0.53x0.53) pitching over bitumen treated geojute/ geosynthetic filter (woven type) conforming to specification laid.	0.23 to 0.30	0.60	1.20	Loose boulder sausage apron of nominal length	0.60	3.00	See Notes below
All other rivers	- do -	0.23 to 0.30	0.60	0.90	Crated boulder 3m x 3m x 0.46 ht placed alternately i.e. 6.0 m c/c	0.46	3.00	- do -

- Note:**
1. Pitching should be extended on bank top and continued for at least 1.50 m with a key at the end if HFL is above bank top.
 2. Variety and minimum weight of boulder is to be considered on the basis of site condition as well as availability.

Zone B (Contd.) All river in North Central, Central, Western and Eastern districts in non tidal zone.

Bank Protection: Type 4B-II/2

Suggested when protection is required to arrest erosion of berm land, which, if continued unabated, may affect the embankment or riverbank line.

Description: Trapizoidalbed bars mostly submerged, with core of loose boulder/geobags of suitable/specified volm covering all around by crated boulder as per Fig 4B-II/2.

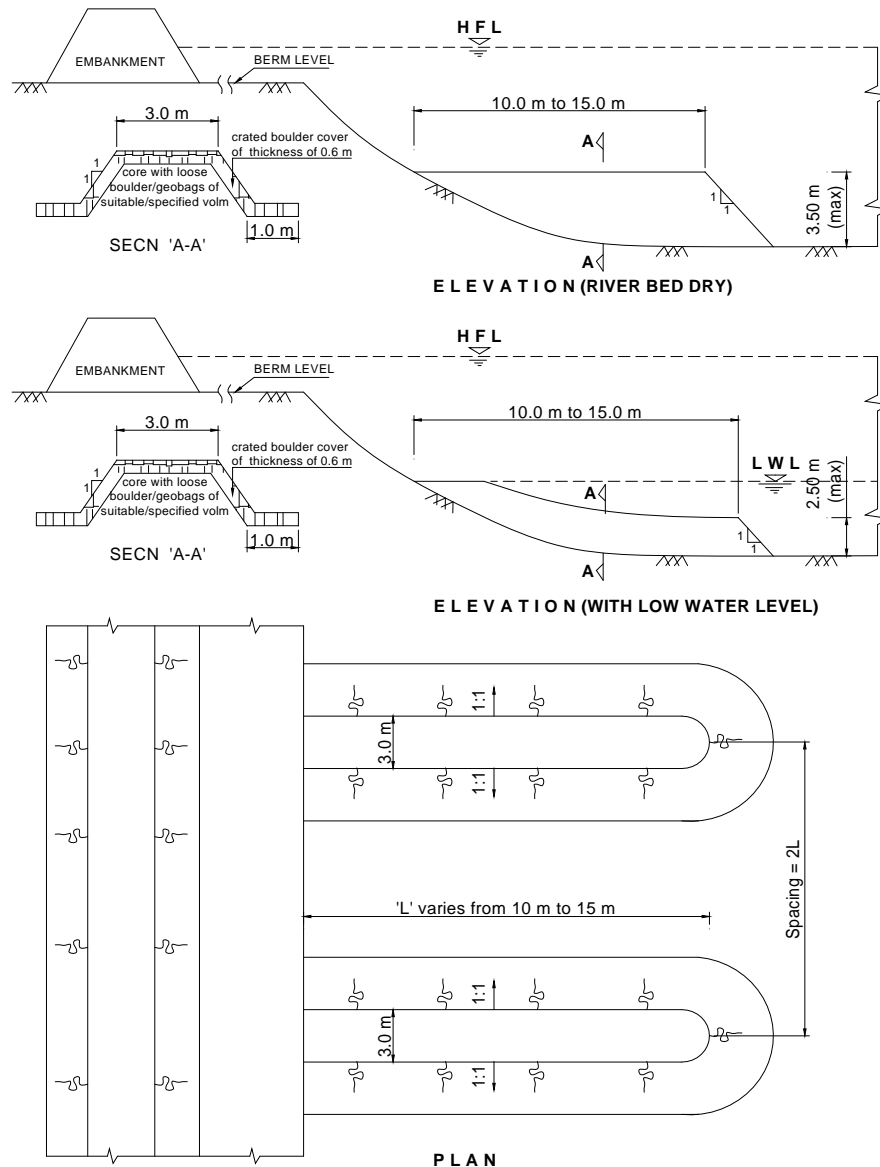

Fig.4B-II/2 (Type 4B-II/2)

6.3 Zone C: Tidal zone in South Bengal (other than Sundarban and coastline of Purba Medinipur)

District covered: Tidal zone of Purba Medinipur, Paschim Medinipur, Howrah, Kolkata, Hooghly, North & South 24-Parganas (other than Sundarban & coastal area of Purba Medinipur).

6.3.1 Sub Zone C-1: Bank slope of river is flatter than 1(V):2.5(H) and calculated scour depth is more than the observed scourdepth.

Bank/Embankment

Protection: Type 5C-I

Description: 0.225 m thick boulder/0.25 m thick brick block /0.3 m thick cement concrete block pitching over a layer of filter supported by toe wall and with occasional use of cylindrical sausage where bed erosion is dominant, as per Fig.5C-I and dimensions as per Table 8.0.

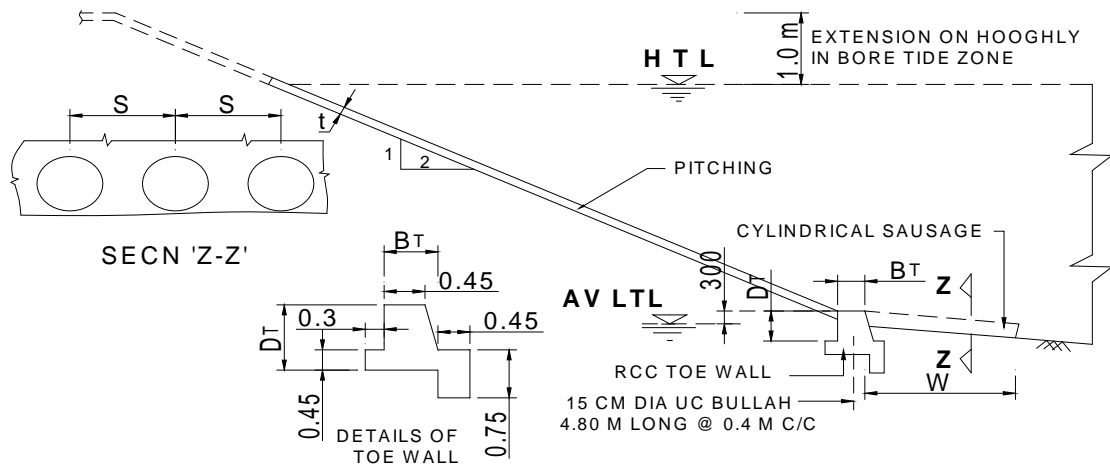

Fig.5C-I (Type 5C-I)

Table – 8.0

River	Type of pitching	Thick-ness of pitching t(m)	Toe Wall			Cylindrical sausage			
			Description	Width B _T (m)	Depth D _T (m)	Description	Length L (m)	Dia D (m)	Spa-cing S (m)
Hooghly (in the zone of bore tide, section narrow)	Cement concrete block pitching over bitumen treated geojute/geosynthetic filter conforming to specification	0.30	RCC toe wall over EUC bullah piles (Refer Note-1 below)	0.60	1.10	–	–	–	–
Hooghly (Other than of bore tide zone)	Boulder/brick block pitching over bitumen treated geojute/geosynthetic filter (woven type) conforming to specification.	0.25 to 0.30	RCC toe wall over EUC bullah piles (Refer Note-1 below)	0.50	1.00	Boulder / brick in wire net cage	6.00	1.00	1.50
River other than Hooghly*	Boulder/brick block pitching over bitumen treated geojute/geosynthetic filter (woven type) conforming to specification.	0.25 to 0.30	Boulder / brick within iron wire crate**	0.60	0.90	Boulder / brick in wire net cage	5.00	0.75	1.15

* Where Bed slope of river is flatter than 1(V):2.5(H) and calculated scour depth is more than the observed scour.

** Toe wall would be rectangular.

Note: 1. As a very special case, Eucalyptus Bullahs may be replaced by more or less 0.4 m wide MS sheet pile of length varying from 6 m to 12 m, at the location of severe scour prone zones. In case of use of sheet piles, the RCC toe beam should be rectangular, without key.

In case of Hooghly river, where bore tide does not occur, the RCC toe beam should also be rectangular, without key.

2. Boulder, minimum weight of which is to be considered on the basis of site condition as well as availability, is preferred over bricks.

6.3.2 Sub Zone C–1I: Bank slope of river is steeper than 1(V):2.5(H) and calculated scour depth is less than the observed scour depth.

Bank/Embankment

Protection: Type 5C-II

Description: Filling up of scour hole, already formed, with crated (Nylon/PP) polybags (i.e. 2nd hand cement bag machine stitched after filling up with sand/silt), formation of a berm at L.W.L, boulder/brick block pitching over a layer of filter from LW L to HWL, after re-grading bank slope but not steeper than 1(V):2(H), as per Fig.5C-II.

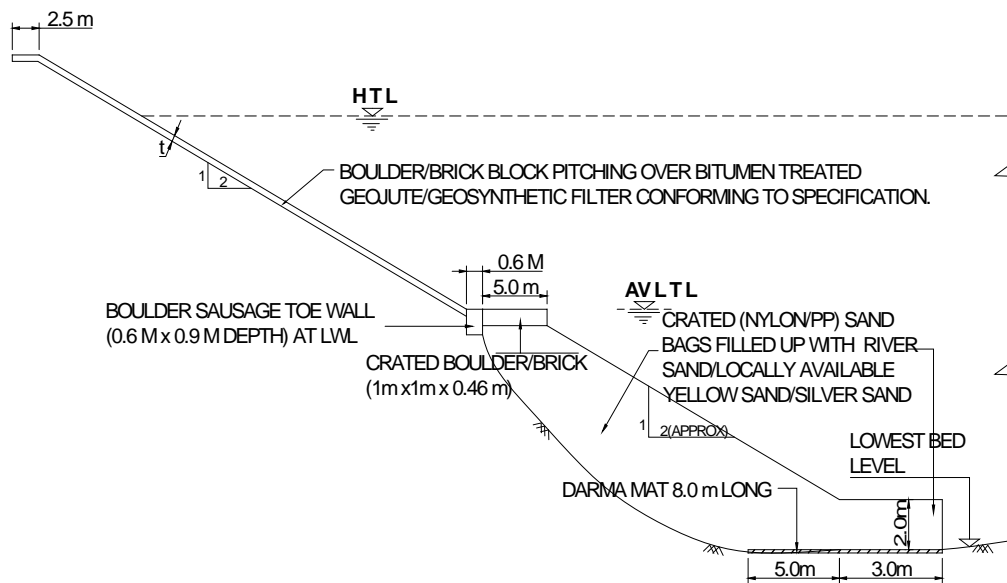

Fig.5C-II (Type 5C-II)

- Note:**
1. Boulder, minimum weight of which is to be considered on the basis of site condition as well as availability, is preferred over bricks.
 2. In case of scour hole filling, the boulder pitching work above LWL should be taken up at least after one monsoon season and HDPE sand bag pitching may be provided as interim measure before pitching work, if required. Also, arrangement should be made to maintain the filled up portion for such period.
 3. ADCP survey is a must to assess the extent of the scour hole.

6.4 Zone D: Coastal protection work in Digha-Shankarpur and adjoining areas

District covered: Purba Medinipur

Embankment/Shore

Protection: Type 6D

Description: Sea wall by laterite stone boulder, brick masonry guardwall at country side, walk way in the form of interlocking paver block, block over cement concrete bank protection on the sea side of sea wall by cast-in-situ cement concrete block over black stone boulder pitching, sheet piling at the toe of protection as per Fig.6D.

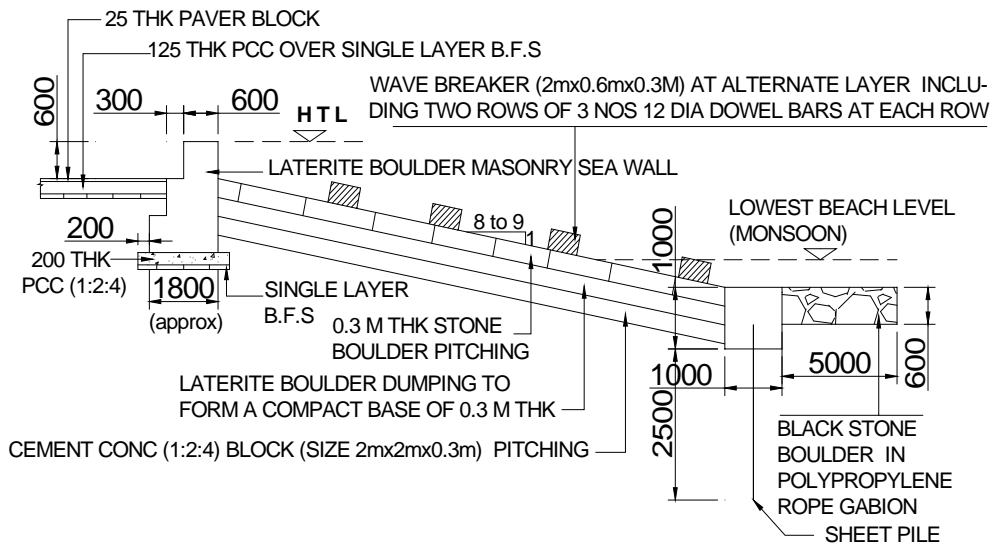

Fig.6D (Type6D)

6.5 Zone E: Sundarban areas in North & South 24-Parganas and Sea dykes in Purba Medinipur away from coastline

District covered: Parts of North & South 24-Parganas and Purba Medinipur

Embankment

Protection: Type 7E

Description: Concrete block pitching / brick block pitching / dry brick pitching on river or seaside slope over woven geosynthetic filter with toe walls as per fig given below with dimensions as per Table 9.0.

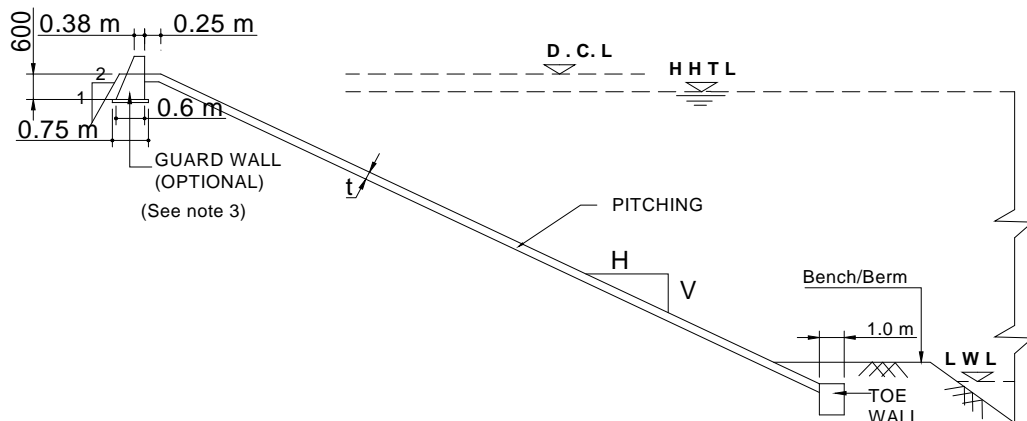

Fig.7E (Type 7E)

Table – 9.0

River / Sea	Type of pitching	Thick-ness of pitching t(m)	Slope of pitching		Design crest level of embankment (DCL)					Toe wall description
			H	V	HHWL Z ₀ (m)	Wave run up γ (m)	Settle-ment S (m)	Free board f (m)	Total Z (m)	
Sea facing dykes	Cast-in-situ M20 concrete block pitching of nominal size 2.2m x 2.2m with appropriate tolerance of $\pm 10\%$ for placing within the panels / compartments.	0.30	5	1	Note-1	2.53	0.30	1.50	4.33	M20 PCC toe wall, of preferably cast in situ, of thickness 0.9m.
River embankment facing or near sea within 7 km upstream of confluence of river with sea	– do –	0.30	5	1	Note-1	2.39	0.30	1.50	4.19	– do –
River embankment beyond 7 km from sea and aligned more or less in north-south direction	0.53 m x 0.53 m brick block pitching over geosynthetic filter	0.25	3	1	Note-1	0.75	0.30	1.50	2.55	Loose brick in iron wire net of total thickness 0.9m.
River embankment beyond 7 km from sea and aligned more or less along east-west & minor creeks / channels.	Dry brick pitching over geosynthetic filter	0.20	3	1	Note-1	0.75	0.30	1.50	2.55	Loose brick in iron wire net of total thickness 0.9m.

- Note: 1. HHTL value to be considered at a particular location as per available data.
2. The value of wave run up, 'γ', calculated from the following formula has been calculated, taking reference from the Project of 'Reconstruction of 'Aila' affected Sundarban Embankment' approved by the MoWR, RD&GR. Settlement has been considered as 0.30 m and free board 1.50 metre as per approved design note of the same project.

$$x = 8H \tan \alpha \cos \beta$$

where, γ = Height of wave run up (m)

H = Height of wave (m)

α = Angle of slope of embankment/dyke

Value of α may be taken as 11.3° for sea dyke and river embankment similar to sea dyke within 3.0 km u/s of confluence of river with sea, 18.4° for other rivers.

β = Angle of approach between the embankment/dyke and the wave crest

Value of β shall be 0° for sea dyke, 15° for river embankment within 3.0 km upstream of confluence of river with sea and 75° for other rivers.

$$H = \frac{(0.17\sqrt{VF} + 2.5 - \sqrt[4]{F})}{3.2808}$$

where, V = Wind speed in miles per hour, considered as 62 miles/hour for river embankment and 78 miles/hour for sea dyke.

F = Fetch in mile, 8.5 mile for sea dyke and 4.0 mile for river embankment.

3. If designed Crest Level (DCL) cannot be attained due to space constraint, a masonry guard wall of suitable exposed height may be constructed to avoid spilling of tidal water over the embankment.
4. In case of Type 7E protection work in Sunderbans, involving berm length of less than 7.5m, 3 rows of tied porcupine cage @3m c/c along the bank line (vertically one cage in each row) are to be placed along the entire length of zone of protection plus 5 metre extra on either side, Center to Center distance between the adjacent rows perpendicular to the flow direction should also be 3 metre and the central row should be staggered in respect to two outer rows.
5. In case of historically subsidence prone areas where concrete blocks are being lifted due to wave action, placement of concrete tetrapod needs to be considered as the wave breaker in the sea / riverside of the protection work as shown below.

Embankment

Protection: Type 7ES (Supplementary to or rehabilitation of Type 7E)

Description: One row of concrete tetrapod over two rows (each weight either 1.2 MT/2.8 MT) to be placed adjacent to the junction of slope and bed/berm, along the bankline and in addition, spurs (two rows at bottom with one row at top) of maximum length 15.0 m and spaced at 30 m c/c to be laid, across the bank line in the entire eroding zone. Length of the two end spurs should be limited to 7.5 m and spacing between the short end spur and the next spur at both the ends should be 15 m. Please refer to Figure 7ES below. Linear protection of embankment /bank must be continued at least for a length of 30 m beyond the end spurs at both ends.

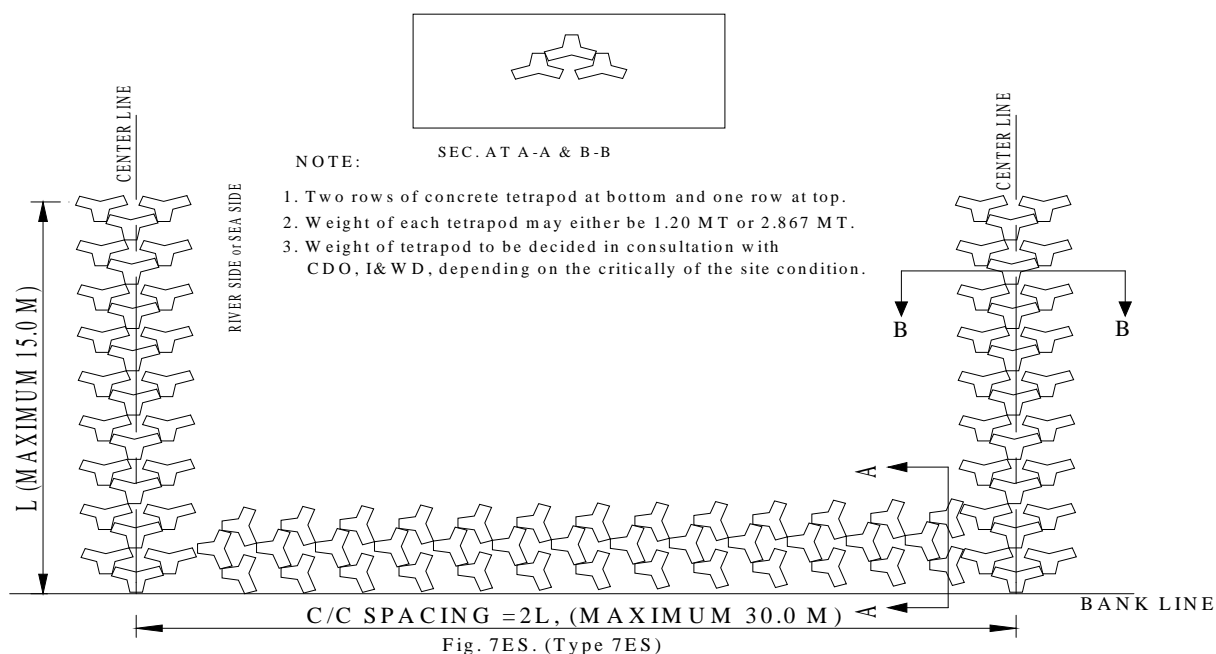

Fig.7ES (Type 7ES)

Note: 1. Weight of tetrapod is to be decided in consultation with Central Design Office, Irrigation & Waterways Directorate.

6.5.1 **Sub-Zone E1: Sundarban areas in North & South 24-Parganas (severely eroding bank on concave side)**

Embankment

Protection: Type 7E/1

Description:

Cluster of bamboo porcupine cages starting from the LWL upto the Lowest bed Level or 30 m, whichever is less, are to be laid perpendicular to the bank line in rows in the entire stretch of the critically eroding zone at concave bends, at a spacing of 30m c/c, as detailed at zone "B" in Figure 7E/1 below, to act as silt arrester. In addition, porcupine spurs are to be laid at the transition zone (where the deep channel has started shifting towards bank line) to act as deflectors as shown in at zone "A" in the said Fig. 7E/1. Refer Notes below the drawings and also the 'General Remarks' at the ends

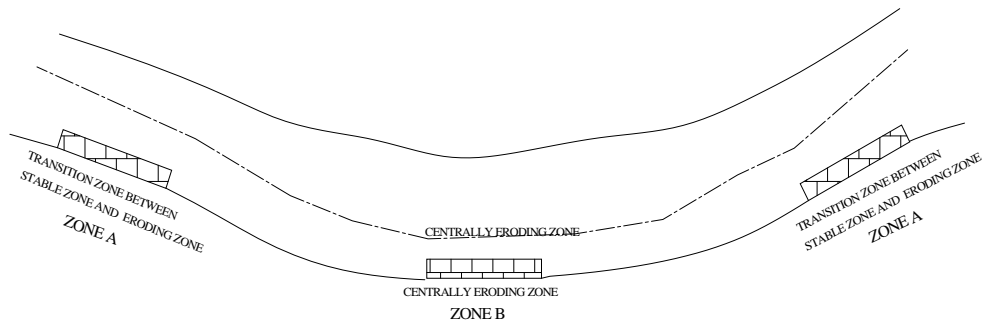
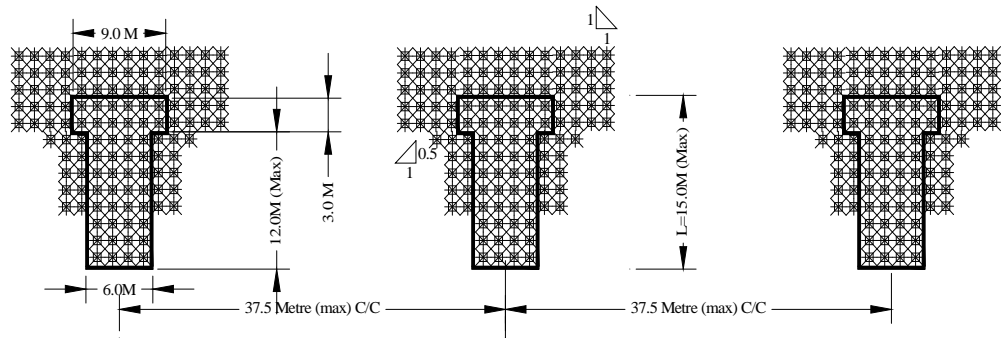
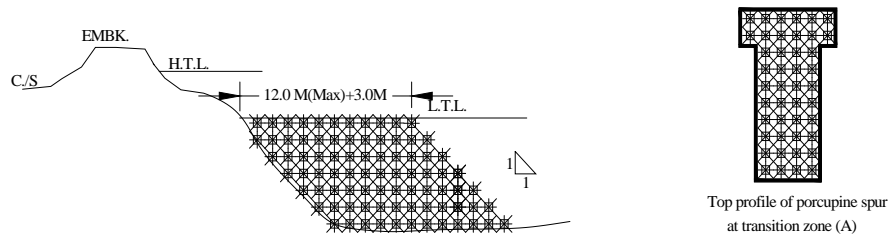

Fig. 7E/1 (Type 7E/1)



Typical plan of porcupine spur at transition zone (Details of "A") @ maximum 37.50 m interval (3 Nos each at Upstream and Downstream side)



Typical cross section of porcupine spur at transition zone (A) @ maximum 37.50 m interval

- NOTE
1. Top Length of the spur (L), should be as per the following formula $L = 0.20 \times W + 3.0 \text{ M}$, subjected to a maximum of 15.0 M, where W = Width of Water way at average L.T.L.
 2. Spacing of spurs should be restricted to $2.5 \times L$ where L = Top length of spur, subject to a maximum of 37.50 M. C/C.

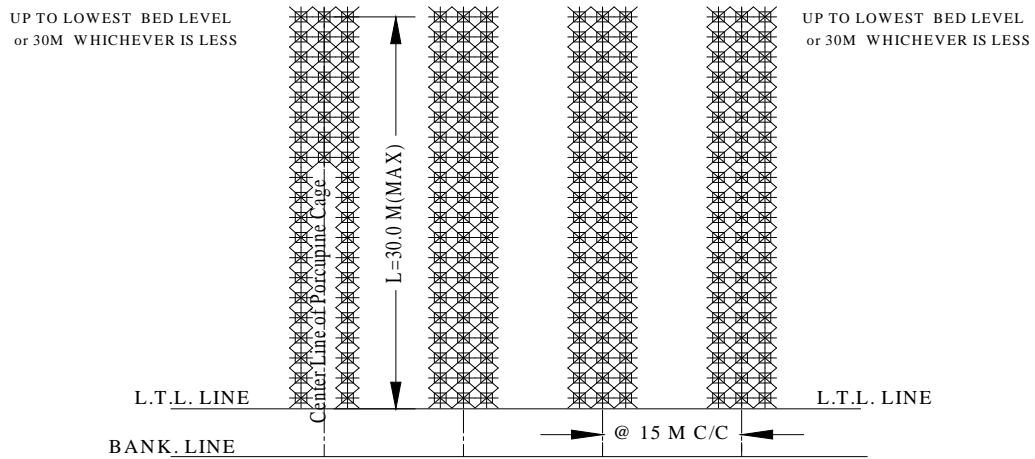

Typical plan of porcupine at eroding zone
(Details of "B") @ 15.0 m interval

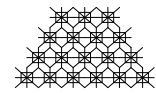
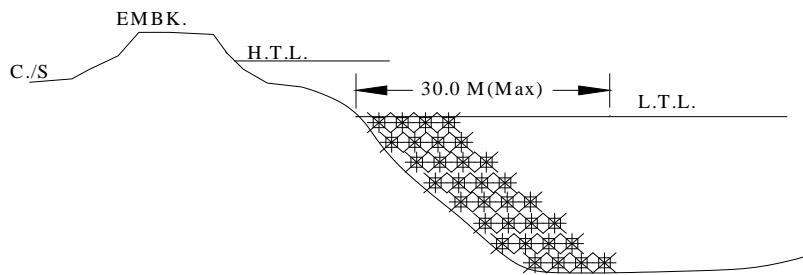

PORCUPINES BEING DUMPED
IN ELEVATION AT "B"

Typical cross section of porcupine at eroding zone (B)

NOTE

1. No permanent work on improvement of embankment should be done in the zone of anti-erosion works using porcupines as shown above, for a period of one year, in order to observe the performance of the anti-erosion works executed. Embankment work in the zone should be restricted to strengthening of countryside with raising if necessary. In case of strong wave action, riverside slope may be protected by earth filled poly bags with darma mat cover or by sand filled HDPE bags as a temporary measure.
2. Porcupine cages to function as spurs at Location 'A' should be placed perpendicular to the bank line in such a way so that top layer is horizontal, more or less flush with the LTL. There should be maximum 3 no. spurs at the transition zone in the upstream as well as downstream. These spurs are supposed to deflect the flow and upstream as well as downstream. These spurs are supposed to deflect the flow and shift the deep channel from the transition zone itself, which is quite away from the critically eroding zone.
3. Porcupine cages shown at Location 'B' are to also to be placed perpendicular to the bank line but along the slope, in such a way so that the number of layers does not exceed four and the top layer of porcupine should not be above the average LTL. These cages are supposed to perform as silt arrester in the critically eroding zone.
4. ADCP survey is a must for ascertaining the bed profile.

Sd/-
12.11.2019
K Basak
Superintending Engineer
North Irrigation Circle – I
Irrigation & Waterways Directorate
& Special Invitee

Sd/-
12.11.2019
S K Laha
Chief Engineer & Project Director
WB Major Irrigation & FM Project
Irrigation & Waterways Directorate
& Special Invitee

Sd/-
12.11.2019
A Bera
Deputy Director (Structure)
Central Design Office
Irrigation & Waterways Directorate
& Member

Sd/-
12.11.2019
A Ganguly
Superintending Engineer
Eastern Circle
Irrigation & Waterways Directorate
& Member

Sd/-
12.11.2019
A Roy
Chief Engineer (North)
Irrigation & Waterways Directorate
& Member

Sd/-
12.11.2019
Dr. Sibapriya Mukherjee
Professor, Department of Civil Engineering
Jadavpur University
& Member

Sd/-
12.11.2019
S Bandyopadhyay
Executive Engineer – I
Joynagar Irrigation Division
Irrigation & Waterways Directorate
& Special Invitee

Sd/-
12.11.2019
P Patra
Chief Engineer
Teesta Barrage Project
Irrigation & Waterways Directorate
& Special Invitee

Sd/-
12.11.2019
G Patra
Superintending Engineer
Western Circle – I
Irrigation & Waterways Directorate
& Member

Sd/-
12.11.2019
T R Barua
Director of Designs
Central Design Office
Irrigation & Waterways Directorate
& Member

Sd/-
12.11.2019
A Basu
Chief Engineer (Design & Research)
Irrigation & Waterways Directorate
& Member-Convenor

Sd/-
12.11.2019
Dr. Dhrubajyoti Sen
Professor, Department of Civil Engineering
IIT, Kharagpur
& Chairman, TEC