



# Thermal Solution Engineering

## Heat Source Control System **Ene-Conductor**



**Significant Energy Reduction**  
by total control of heat source system !!  
It's a conductor of Energy

# Significant Energy Reduction by total control of heat system

~optimization from individual equipment to whole system~

Being required for contemporary office buildings, large shopping malls or factories, it is an environmental protection effort and saving energy but the key issue is the heat source system. Energy-saving had to introduce high efficiency equipment some years ago. However it has to consider energy saving on heat source system levels rather than individual equipment. We is the "Ene-Conductor" which supports energy-savings for the whole system.

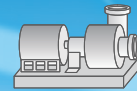
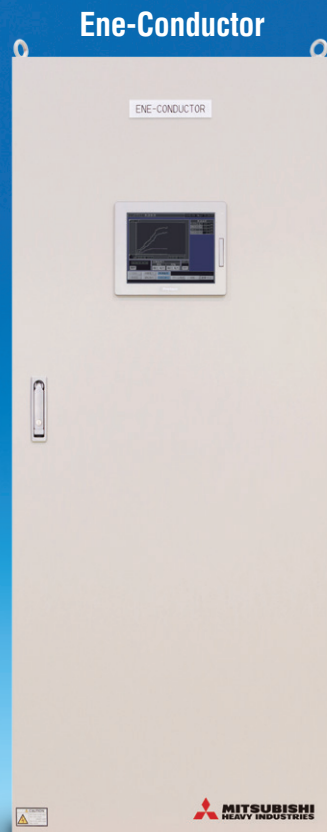

Pump



Cooling tower

Heat Source Control System

## Ene-Conductor

Improvement of system COP by optimal control which gets the best performance out of centrifugal chiller



Various energy-saving control functions



Remote monitoring



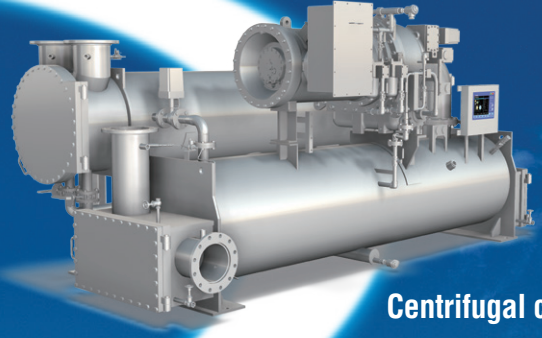
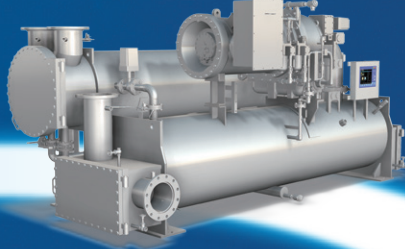

Centrifugal chiller

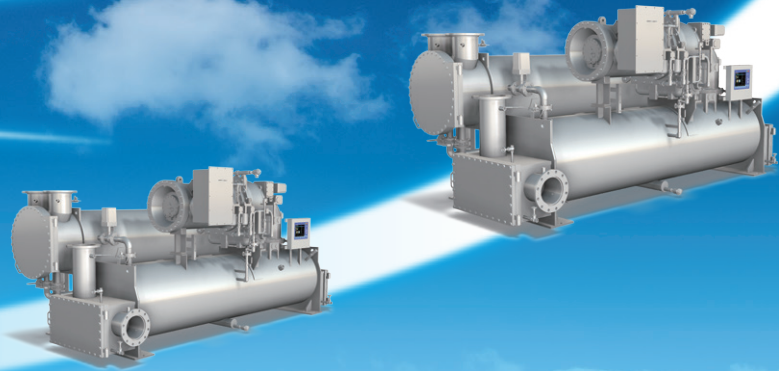

# Electric power consumption **↓ 65% down** in whole system

Estimation example

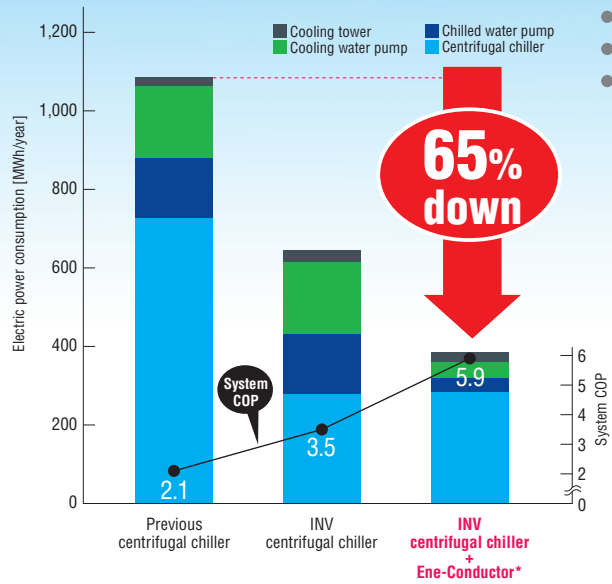

- Improvement in COP of centrifugal chiller
- Chilled water variable flow control
- Cooling water variable flow control

**Easy to use for an automatic optimization of the whole system**

Estimation condition : chiller 400 RT x 2units, Building air conditioner use  
 \* Auxilliary equipment : controlled by inverter

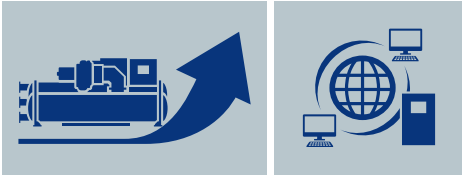

# Improvement of system COP

## 1 Improvement of system COP by optimal control which gets the best performance out of centrifugal chiller

### Optimize load distribution and operation number

In the case where the system combines multiple chillers with different performances, Ene-Conductor automatically calculates the best load for each chiller to obtain the highest COP of the complete system.

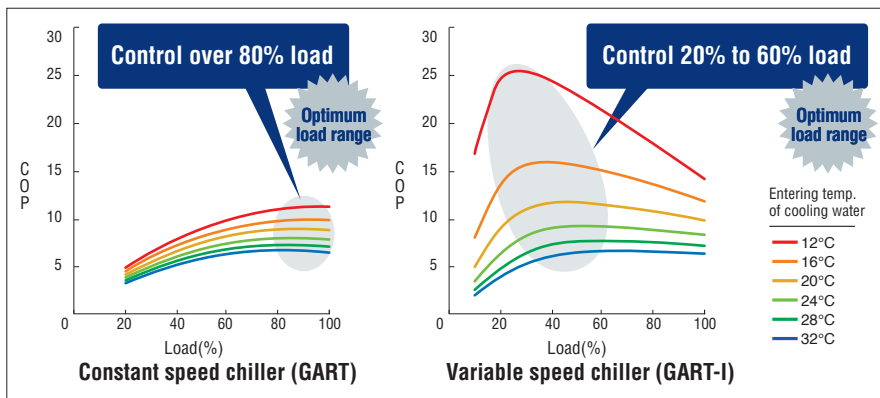

## 2 Various energy-saving control functions

Packaged control software of the heat source equipment. The system design work load is reduced for the customer.

- Multiple chiller and heat pump number control
- Chilled / Hot water variable flow rate control (primary pump)
- Cooling water variable flow rate control
- Cooling tower operation / fan control
- Cooling water bypass valve control
- Chilled water bypass valve control
- Chilled / Hot water secondary pump control

## 3 Remote monitoring program (WEB communication)

(Option) Commitment of maintenance program is required

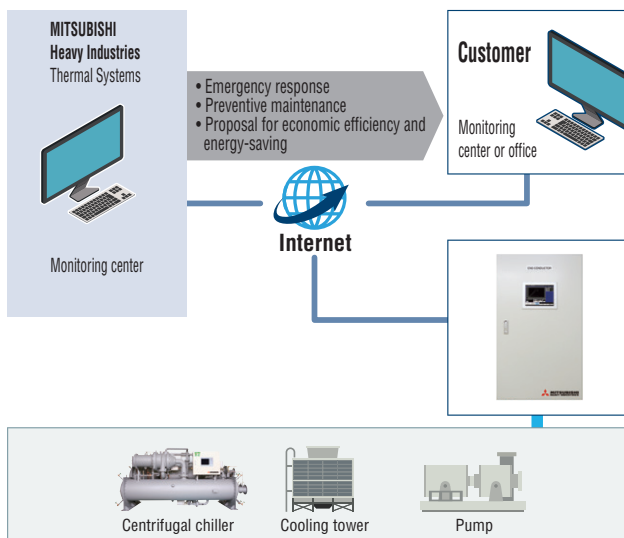

This program is not available for poor quality internet connections environment.

## 4 Central monitoring (Option)

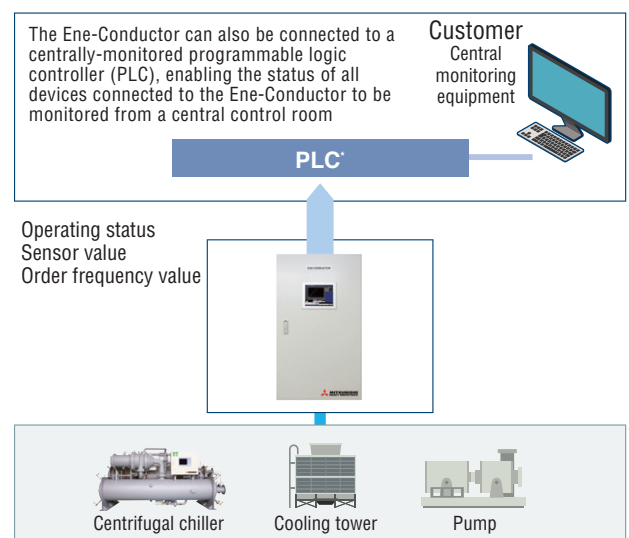

\* PLC: MODBUS/RTU Communication module



# Easy Operation

## 10.4inch touch screen panel with LCD

### System diagram

Various information is displayed on the system diagram of the main screen.

**TR-1 Operating Data**

01 Control Mode	Auto
02 Status	Running
03 Cooling Load	1500 kW
04 CHW Entering Temp	14.0 °C
05 CHW Leaving Temp	7.0 °C
06 CHW Entering Temp	32.0 °C
07 CHW Leaving Temp	37.0 °C
08 COND Pressure	0.00 MPa
09 EVAP Pressure	0.00 MPa
10 Lube Oil Pressure	0.00 MPa
11 Oil Tank Temp	0.0 °C
12 Valve Opening	0.0 %
13 INV FREQ	0.0 Hz
14 Motor Current	0.0 A
15 Wattage	0.0 kW
16 COP	0.00
17 Optimal COP	0.00

**CT-1 Operating Data**

01 Control Mode	Auto
02 Status	Running
03 CT Leaving Temp	32.0 °C
04 CW Target Temp	0.0 °C
05 INV FREQ	60.0 Hz
06 Wattage	0.0 kW

**System Diagram**

DB Temp: 30.0 °C, RH: 60.0 %, WB Temp: 24.0 °C, System Load: 2850.0 kW, System Wattage: 550.0 kW, System Gas: — mph, System COP: 0.00

Pop-up display of detail data

- System data (Power / Heat load / COP)
- Devices status by symbol (Stop / Running / Failure)
- Device detail data on pop-up display
- Various sensors value

### Operation screen

**Operation - System**

System Operation: Pause, Local, Remote, Schedule, Stop, Run, Alarm

Priority Order: Man, Rotate, Averaging, Set, Present Order

Control Method: Temp, Flow, Load, Flow+Load, Condition, Local, Remote, Cooling, Heating

System Diagram | **Operation** | Trend | Alarm List | Data | Alarm Reset

- Switching of system operation mode (Pause / Local / Remote / Schedule)
- Setting for chiller operation order (Manual / Rotation / Averaging)
- Setting for control method (Temperature / Flow / Load / Flow + Load)
- Setting for supply water temperature
- Start-stop individually order for chiller, cooling tower etc.

### Schedule screen

**Schedule**

Schedule1: Invalid, Valid, Stop, Run, Daily, Cont, Forcing, Set, Start 08:00:00, Stop 19:00:00

Schedule2: Invalid, Valid, Stop, Run, Daily, Cont, Forcing, Set, Start 08:00:00, Stop 08:00:00

Schedule3: Invalid, Valid, Stop, Run, Daily, Cont, Forcing, Set, Start 08:00:00, Stop 08:00:00

System Diagram | **Operation** | Trend | Alarm List | Data | Alarm Reset

- Setting for weekly schedule pattern, max. 3 patterns
- Example :- Daily pattern : from 8:00 to 19:00 of Mondays, Wednesdays and Fridays
- Continuance pattern : from Mondays 8 :00 to Fridays 19:00

### Trend graph screen

**Trend Graph - Load**

Load [kW]

System: 885 kW, TR-1: 690 kW, TR-2: 175 kW, TR-3: 0 kW

Zoom, Scaling, Time, Value

System Diagram | **Operation** | Trend | Alarm List | Data | Alarm Reset

- Display max.24hours of trend graphs
- COP : Chiller and System
- Power consumption : Chiller and System
- Load : Chiller and System
- Typical data of heat source system (Supply chilled water flow rate, Supply/Return temperature, outside air condition)

### Alarm history screen

**Alarm List**

Date	Time	Message	Restore	Display
12/05/24	15:44	System Tower2: Failure		Display
12/05/24	15:44	System Tower2: Status Error		Hide
12/05/24	15:44	System Tower2: Failure		
12/05/24	15:44	System CW Pump3: Failure		
12/05/24	15:44	System CW Pump2: Failure		
12/05/24	15:44	System Chiller2: Status Error		
12/05/24	15:44	System Chiller3: Status Error		
12/05/24	15:39	System AI-20: Chiller1 CHW Flow	15:39	
12/05/24	15:39	System AI-09: CHW Return Temp	15:39	
12/05/24	15:39	System AI-08: CHW Supply Temp	15:39	
12/05/24	15:38	System Chiller3: Failure	15:38	
12/05/24	15:38	System Chiller2: Failure	15:38	

Legend: Alarm Arise, Alarm Restore

System Diagram | **Operation** | Trend | Alarm List | Data | Alarm Reset

- Display max.128 of alarm history



# Various energy-saving control functions

## Primary-Only Pumping system

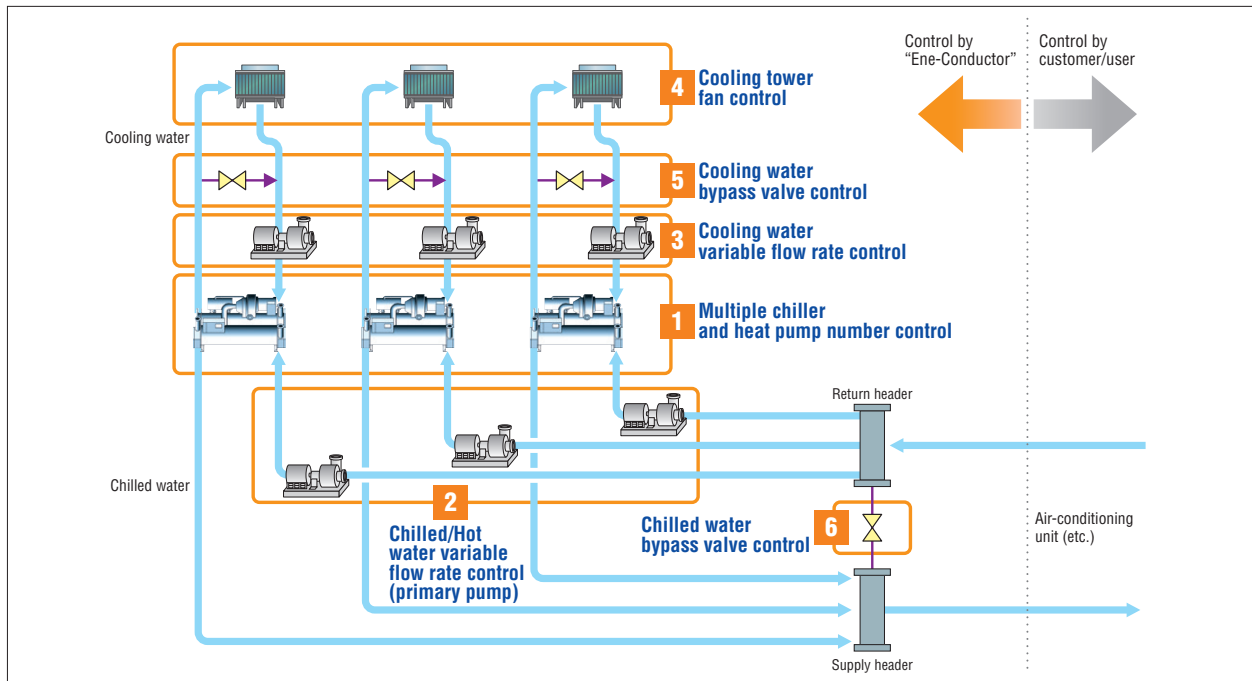

## Primary-Secondary Pumping system

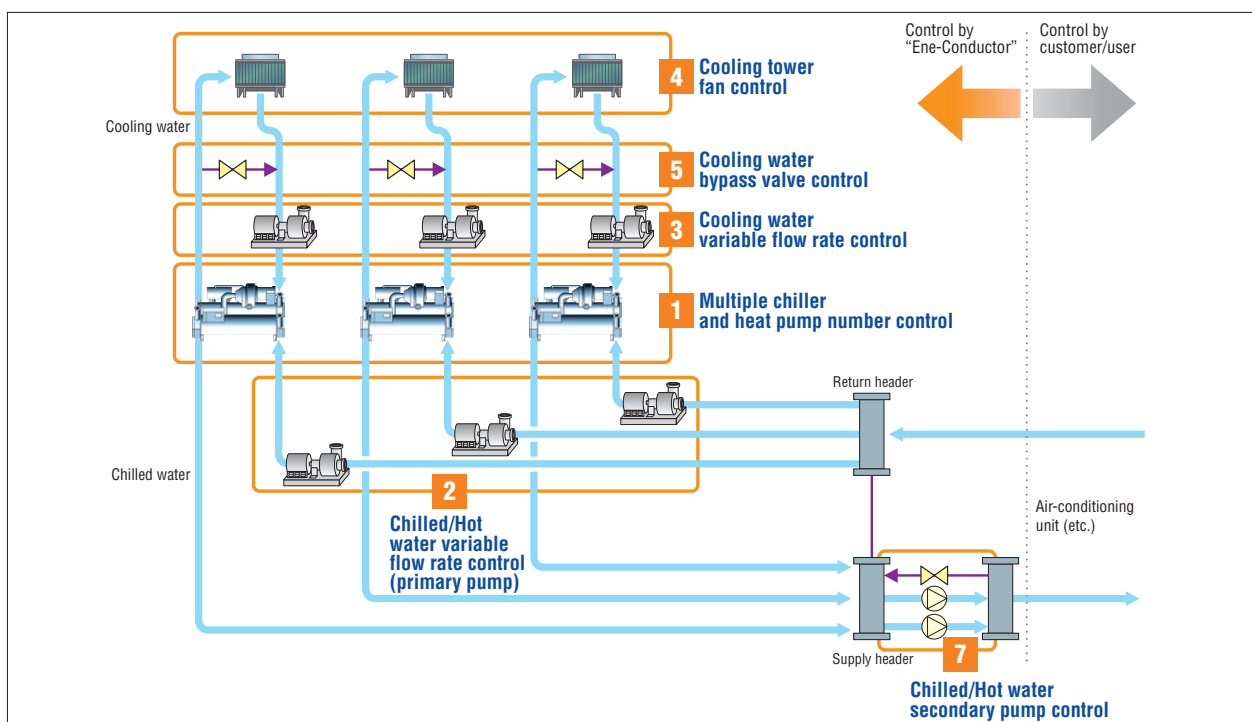

□ : Control by "Ene-Conductor"

□ : "Ene-Conductor" refers to operation status

# 1 Multiple chiller and heat pump number control

MTH\* original (Patent approval)

Energy Saving Level ★★

"Ene-Conductor" will decide on the number of chillers to start/stop and the load conditions of each chiller for optimizing performances:

- Energy savings by the amount of chillers to start/stop automatically
- Automatic determination of operation order (manual settings are also available)

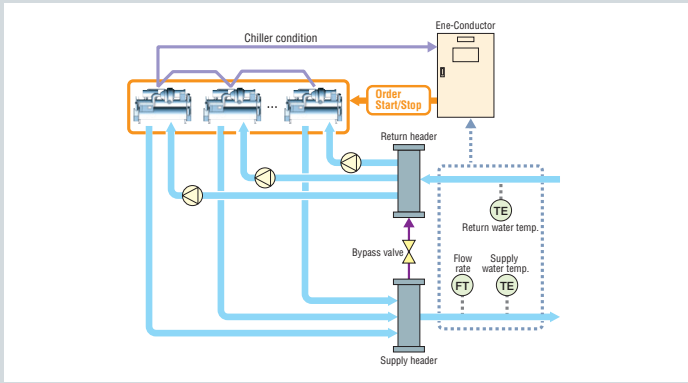

# 2 Chilled/Hot water variable flow rate control(Primary pump)

MTH\* original (Patent approval)

Energy Saving Level ★★

"Ene-Conductor" will control the chilled water supply flow rate for closing the bypass valve (bypass flow rate is zero) by the pump frequency.

- Reduction of the pump energy consumption depending on the load
- Flexibility to maximize the cooling capacity by increasing the flow rate of the chilled water and, consequently, taking advantage to operate the right number of chillers.

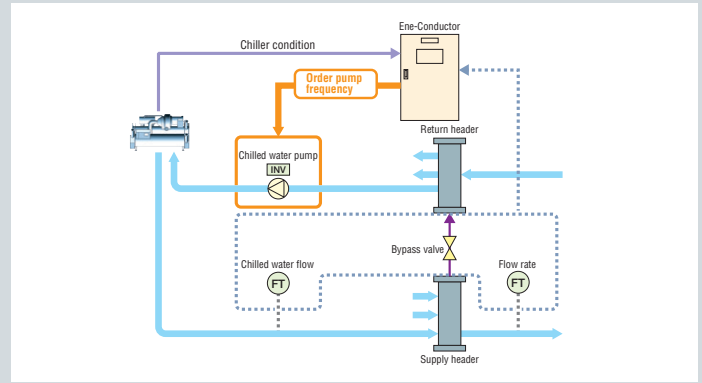

# 3 Cooling water variable flow rate control

MTH\* original (Patent approval)

Energy Saving Level ★★

Depending on the chillers' load conditions and the outside air conditions, "Ene-Conductor" will control the cooling water flow rate by the pump frequency.

- Reduction of cooling water pump energy consumption

Note: The chiller energy consumption is slightly increased due to a higher cooling water outlet temperature

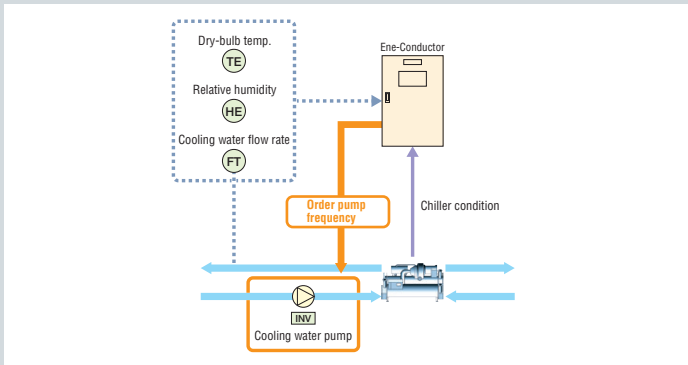

# 4 Cooling tower fan control

MTH\* original (Patent approval)

Energy Saving Level ★★

"Ene-Conductor" will select the number of cooling towers in operation depending on the chillers' load conditions and the outside air conditions. It controls the start/stop of the cooling tower fans depending on outside air conditions and the minimal cooling water temperature.

- Lowering the cooling water temperature → higher efficiency operation of the chillers
- Optimizing the number of cooling towers in operation → reducing the energy consumption of the fans

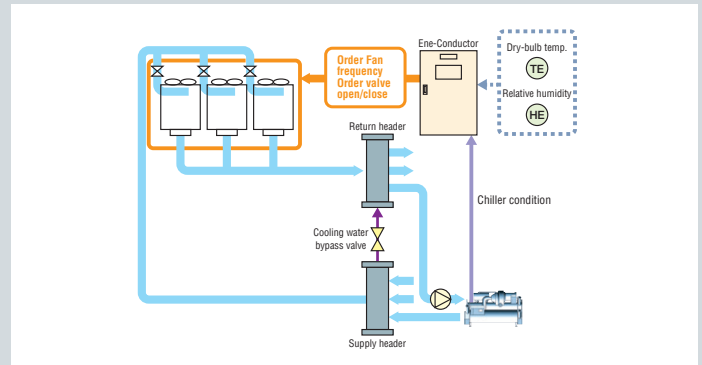

# 5 Cooling water bypass valve control

"Ene-Conductor" is going to open/close the bypass valve depending on the minimal temperature selected from the chillers.

- Stable operation of chillers at low outside temperature
- The chiller operates by a constant acquisition of the minimal cooling water temperature which depends on the chiller operating conditions (supply water temperature/chiller load conditions).

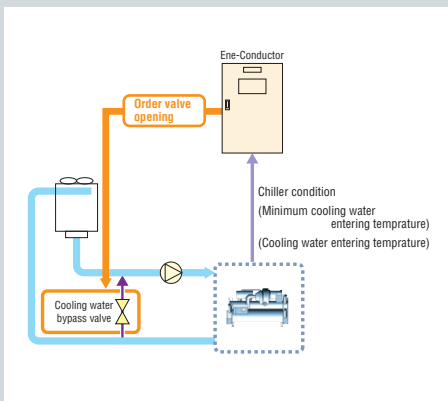

# 6 Chilled water bypass valve control

Maintain pressure in the chilled water system constant by continuous differential pressure control.

- Control style:select from 3styles;
  - Fixing supply pressure
  - Fixing estimated terminal differential pressure
  - Fixing terminal differential pressure
- Stable supply pressure of chilled water

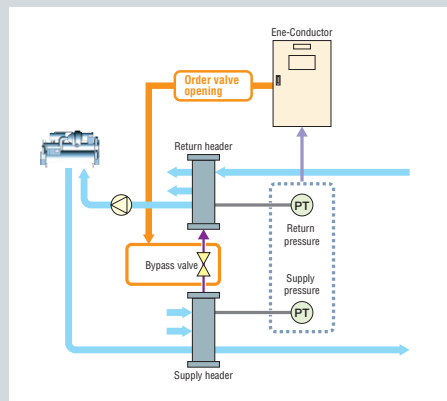

# 7 Chilled/Hot water secondary pump control

"Ene-Conductor" will decide on the number of secondary pumps to start / stop for enough supply flow rate of chilled water. "Ene-Conductor" will control pump frequency and the pressure relief valve opening for supply designed pressure.

- Control style:select from 3styles;
  - Fixing supply pressure
  - Fixing estimated terminal differential pressure
  - Fixing terminal differential pressure
- Suppress hunching by cooperating with multiple chiller control

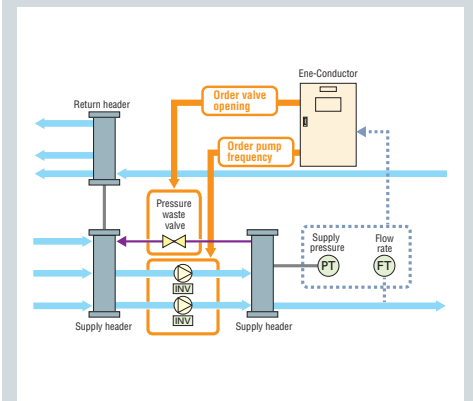

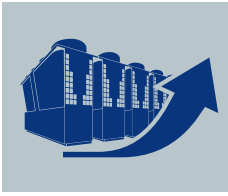

# Air to Water Heat Pump Chiller **MSV<sup>2</sup>** optimum control (only for Japan)

## Package control max.120units (20units x 6sets)

Operate max.8400HP as well as 1unit

### Heat Source Control System "Ene-Conductor"

Optimizing the number of  
heat source equipment, max.6sets

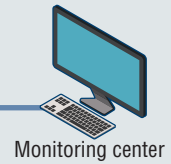
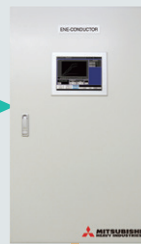

24hrs and 365days Remote Monitoring Program

(Option)



## Control function list

No	Item	Unit Control	Control by MSV Controller	"Ene-Conductor"	Control by Heat Source Control System "Ene-Conductor"
1	Multiple heat pump control	—	○ max.20 units Optimizing the load balance between the operation of the units	<ul style="list-style-type: none"> <li>In the case of direct connection with the Ene-Conductor without the MSV controller</li> </ul> ○ max.6units Optimizing the load balance between the operation of the units	<ul style="list-style-type: none"> <li>In the case of a connection with the Ene-Conductor through the MSV controller</li> </ul> ○ max.120units (6sets of heat source equipment) Optimizing the load balance between the operation of the units
2	Rotating operation time	○ Operate modules by rotation in the operation time	○ Operate by rotation in the operation time	○ Operate by rotation in the operation time and set priority order	○ Operate by rotation in the operation time and set priority order
3	Chilled/Hot water variable flow rate control (Primary pump)	○	○	○	○
4	Chilled/Hot water secondary pump control	×	○	○	○
5	Chilled water bypass valve control	○	○	○	○
6	Connection with centrifugal chiller Centrifugal chiller auxiliary control	—	—	○	○



Mitsubishi Heavy Industries  
Thermal Systems's Strength

## Control mixed with centrifugal chiller

Heat Source Control System  
"Ene-Conductor"

Optimizing the number of  
heat source equipment, max. 6 sets

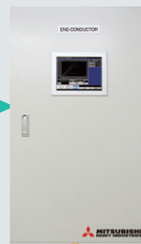

Internet



Monitoring center

24hrs and 365days Remote Monitoring Program

(Option)

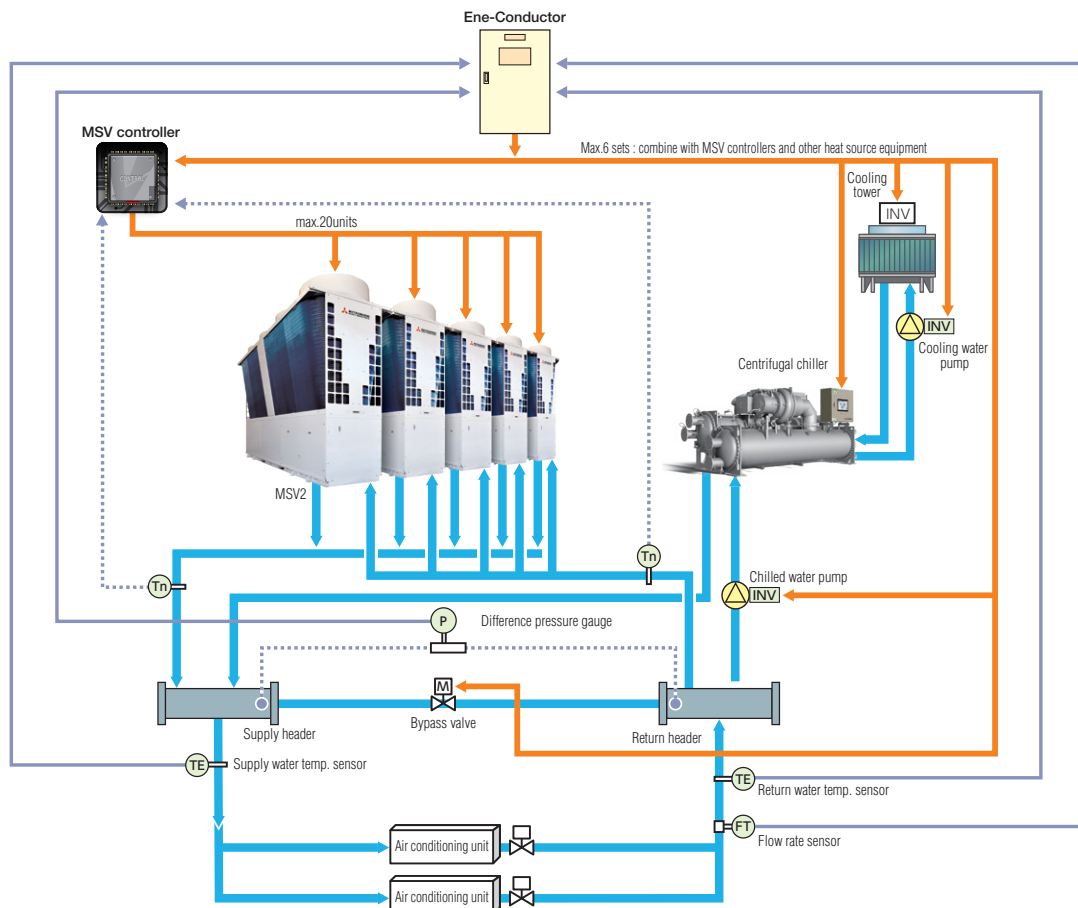

# Specification

\*MTH : Mitsubishi Heavy Industries Thermal Systems, Ltd.

Item	Standard specification		Option specification
Model	EC-3	EC-6	
No. of control chiller	1~3 units	1~6 units	
No. of cooling tower	1~3 units	1~6 units	EC-3:1~6 units (Add IO board)
Dimensions (mm)	L700 × D350 × H1300	L800 × D500 × H1800	
Weight (kg)	Approx. 130	Approx. 240	
Installation Site condition	Indoor installation (Install at a place not exposed to rain, wind, direct sunlight, salt and steam. The adverse environment such as suspending oil-mist, dust or dirt, corrosive gas or flammable gas should be avoided. Use within the range of 0~40°C for ambient temperature and 5~95% for ambient humidity.)		
Installation method	Wall hung	Standing	EC-3:Provide the mounting for self-support by MTH.
Power specification	Control power: 100~125V, 50Hz/60Hz		Control power: 200~220V, 50Hz/60Hz (add transformer)
Target model	Centrifugal chiller (GART, GART-I, GART-ZE, GART-ZEI, AART, AART-I, ETI, ETI-ES, ETI-Z *2) Centrifugal heat pump (ETW*3) ATW heat pump chiller (MSV2, MSV, VOXCEL)		Consult with MTH* for centrifugal chillers not listed in the left column or other companies centrifugal chillers, Absorption chiller, ATW heat pump chiller (add IO board)*1
Auxiliaries to be controlled	Primary chilled/hot water pump, secondary chilled/hot water pump, cooling water pump, cooling tower		Standard specification only The load side equipment such as air conditioning unit should be separately controlled by customer's equipment.*4
Control function *5	Multiple chiller and heat pump, Chilled/Hot water variable flow rate control (primary pump, excess flow control), Cooling water variable flow rate control, Cooling tower operation/fan control (variable air volume control or ON/OFF control), Cooling water bypass valve control, Chilled water bypass valve control, Chilled/Hot water secondary pump control (variable flow control and bypass valve control)		<ul style="list-style-type: none"> <li>•Instantaneous power failure restart</li> <li>•Demand restriction</li> <li>•Stabilization of supply water temperature</li> <li>•Increase correction of supply water temperature</li> </ul>
Screen display	System diagram, operation setting, schedule setting, trend graph, alarm list, control parameter setting screen with password		
display	Stop: Green Operation: Red Fault condition: Flashing orange		① Stop: Red, Operation: Green, Fault condition: Flashing orange ② Stop: Green, Operation: Red, Fault condition: Flashing yellow ③ Stop: Red, Operation: Green, Fault condition: Flashing yellow
Individual failure display	Failure names are displayed on the liquid crystal touch panel.		Individual output is possible by external communication.
Remote start/stop signal	Dry contact pulse signal (Start-up a contact, stop a contact)		Dry contact continuous signal
External signal output (Digital)	Input signal of start, stop, emergency stop Output signal of operation (stop), failure, minor failure, cooling (heating)		Individual output is possible by external communication.
External signal output (Analog)	Input signal of supply water temperature setting		Individual output is possible by external communication.
External communication function	—		"Web communication", "PLC Communication", "Modbus communication" are available.
Painting	Munsell 5Y7/1 (Half gloss)		
Power wire leading direction	Lead-in from lower part	Lead-in from upper part	
Signal isolating	Analog signals are all non-isolated. Please perform the insulating work on analog signals at customer's equipment.		

\*1: Please consult with MTH\* \*2: Exclusion model: heat recovery model \*3: Connect equipment consisting of only ETW.

\*4: Please control boiler and thermal storage tank by customer \*5: Apply to 2 pipes system

## Scope of supply

\*MTH : Mitsubishi Heavy Industries Thermal Systems, Ltd.

Item	Content	MTH* scope	Out of MTH* scope	Comments
Equipment design	Equipment design		○	
Main body	Control panel (Ene-Conductor)	○		
	Parameter adjustment	○		Set before shipment and at site commissioning
Peripheral devices	Chiller		○	MTH*'s scope of work if the chiller is also purchased.
	Auxiliary		○	Primary chilled/hot water pump, cooling water pump, cooling tower, secondary chilled/hot water pump
	Auxiliary power panel (including inverter and isolator)		○	For Primary chilled/hot water pump, cooling water pump, cooling tower, secondary chilled/hot water pump
	Control valve		○	Main pipe bypass valve, pressure relief valve cooling water bypass valve, cooling tower passing water valve
	Equipment sensor		○	Pressure sensor, temperature sensor, flow sensor
Accessories	Instruction manual	○		
Shop test / inspection	Appearance inspection	○		
	Test to approve the parameter setting	○		
Delivery & Installation	From factory FOB KOBE port in Japan	○		Please consult with MTH* about CIF, specified warehouse in Japan etc.
	Foundation		○	Unloading, hanging, lifting, horizontal pull, delivery to site, etc. are out of MTH*'s scope.
	"Ene-Conductor" installation		○	Installation to foundation or wall surface and installation of foundation bolts are out of MTH*'s scope.
	Storage		○	Maintenance management after delivery is out of MTH*'s scope.
	Entire delivery and installation of peripheral devices		○	
Electric works	From power source to automatic control panel		○	
	From automatic control panel to chiller control panel		○	Chiller is out of MTH*'s scope of supply. If a chiller is purchased from MTH*, it will be the MTH*'s scope of supply.
	From automatic control panel to auxiliary power panel		○	Auxiliary power panel is out of MTH*'s scope of supply.
	From automatic control panel to control valve		○	Control valve is out of MTH*'s scope of supply.
	From automatic control panel to equipment sensor		○	Equipment sensor is out of MTH*'s scope of supply.
	From automatic control panel to remote monitoring panel		○	
	From power source to chiller		○	
	From power source to auxiliary power panel		○	Auxiliary power panel is out of MTH*'s scope of supply.
	From auxiliary power panel to auxiliary equipment		○	Auxiliary equipment is out of MTH*'s scope of supply.
	Grounding work		○	
Electric wiring counter check		○	Please perform it before trial operation adjustment in principle.	
Operation	Existing chiller program change	○		If the existing chiller is MTH*'s chiller, program change will be conducted for communication.
	Site trial operation adjustment		○	Please perform the trial operation according to MTH* operating instruction manual.
Paint works	Control panel (Ene-Conductor) painting	○		Painting color is munsell 5Y-7/1 (Half gloss)
Appurtenant works	Foundation work		○	
	Foundation bolt		○	1 set
	Piping work		○	Include the installation of control valves and equipment sensors.
Others	Cooling water quality control		○	Please be aware that the water quality needs to meet the standards (JRA-GL-02-1994) of the Japan Refrigeration and Air Conditioning Industry Association. Water treatment is out of scope of "heat source control system Ene-Conductor" control.
	Electric, water, etc. for site assembly		○	Please supply free of charge.
	Electric, water, etc. for site trial operation		○	Please supply free of charge.
	Entire load side equipment, control and adjustment		○	Load side equipment such as air conditioning unit is out of MTH*'s scope.
	Post handling of packing material for shipment		○	

In the case of adding an "Ene-Conductor" system to existing equipment, please contact MTH\* as the scope is different from above.

# HEAT SOURCE SYSTEM "Ene-Conductor" CHECK LIST

Please fill in the below blanks ( \_\_\_\_\_ underlined, check  )

\_\_\_\_\_ / \_\_\_\_\_ / \_\_\_\_\_  
day / month / year

Company name : \_\_\_\_\_ Project name : \_\_\_\_\_

Site location : \_\_\_\_\_

Contact person : \_\_\_\_\_ Tel : \_\_\_\_\_

Fax : \_\_\_\_\_ E-mail : \_\_\_\_\_

Estimated delivery date : \_\_\_\_\_

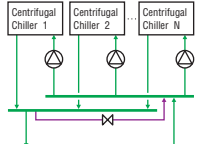
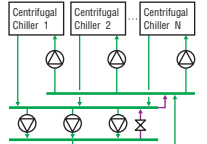
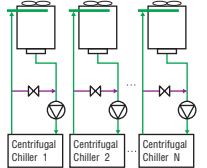
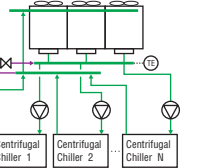
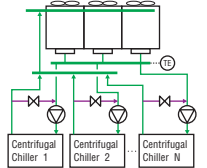
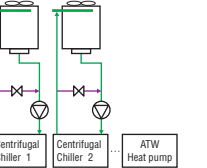
<b>1. Installation</b>	<input type="checkbox"/> Install with chiller <input type="checkbox"/> Add "Heat source control system Ene-Conductor" to existing chiller		
<b>2. Application</b>	<input type="checkbox"/> Air-conditioning for building <input type="checkbox"/> Air-conditioning for factory <input type="checkbox"/> Production/manufacturing process in factory <input type="checkbox"/> D.H.C. <input type="checkbox"/> Other	If other, please fill in this space	
<b>3. Heat source equipment</b>	<b>Centrifugal chiller</b> <input type="checkbox"/> GART/GART-1 ( Unit) <input type="checkbox"/> ETI ( Unit) <input type="checkbox"/> GART-ZE/ZEI ( Unit) <input type="checkbox"/> ETI-Z ( Unit) <input type="checkbox"/> AART/AART-1 ( Unit) <input type="checkbox"/> Other ( Unit) <input type="checkbox"/> NART/NART-1 ( Unit)	<b>Heat pump</b> <input type="checkbox"/> ATW Heat pump chiller ( Unit) <input type="checkbox"/> WTW Centrifugal heat pump ETW ( Unit) <input type="checkbox"/> Absorption chiller ( Unit) <input type="checkbox"/> Other ( Unit)	
<b>4. Control function</b>	<input type="checkbox"/> Multiple chiller and heat pump control <input type="checkbox"/> Chilled/Hot water variable flow rate control (Primary pump) <input type="checkbox"/> Cooling water variable flow rate control <input type="checkbox"/> Cooling water bypass valve control <input type="checkbox"/> Chilled/Hot water secondary pump control <input type="checkbox"/> Chilled water bypass valve control <input type="checkbox"/> Cooling tower/fan control ( <input type="checkbox"/> Constant speed <input type="checkbox"/> Variable/INV )	<b>Not MTH product</b> <input type="checkbox"/> Centrifugal chiller ( Unit) <input type="checkbox"/> Absorption chiller ( Unit) <input type="checkbox"/> ATW Heat pump chiller ( Unit)	
<b>5. Equipment configuration</b>	<b>Chilled water/hot water system</b> <input type="checkbox"/> 2-pipe, primary-only pumping system 	<input type="checkbox"/> 2-pipe, primary-secondary pumping system 	<input type="checkbox"/> Other (If other, please fill in this space)
	<input type="checkbox"/> 1 cooling tower and 1 bypass valve for each chiller 	<input type="checkbox"/> Integrated cooling tower, integrated bypass valve 	<input type="checkbox"/> Other (If other, please fill in this space)
	<input type="checkbox"/> Integrated cooling tower, 1 bypass valve for each chiller 	<input type="checkbox"/> Centrifugal chiller with ATW heat pump chiller 	

### Workflow

== from inquiry to submitting specification/quotation ==

#### Confirmation1

**Control function**

Confirm customer's requests

**Equipment**

Confirm about the following items  
 -Specification of heat source equipment connected with "Ene-conductor".  
 -System diagram of existing equipment.

↓

#### Determination of suitable control function

Determine applicable and suitable control functions on the basis of equipment specification.

↓

#### Confirmation2

**Specification**

Submit the following documents  
 -specification of sensors selected by MTH\*  
 - procedure of power distribution work

Determine control functions after consultation the following items with customer.  
 - Adaption or rejection of sensors selected by MTH\*  
 In case of adaption sensors: confirm signal range

**Option**

Confirm customer's requests

Submit specification and signal list, in case of applying of external communication functions.

↓

Submit final specification and quotation.

\*MTH : Mitsubishi Heavy Industries Thermal Systems, Ltd.

http://mth.mhi.com

## Mitsubishi Heavy Industries Thermal Systems, Ltd.

(Wholly-owned subsidiary of MITSUBISHI HEAVY INDUSTRIES, LTD.)  
 2-3, Marunouchi 3-chome, Chiyoda-ku, Tokyo, 100-8332, Japan  
 inquiry-daiei@mth.mhi.co.jp

Because of our policy of continuous improvement, we reserve the right to make changes in all specifications without notice.

This brochure is applied for the following countries.  
 Republic of Korea, Hong Kong, Macau, Republic of China, Thailand, Singapore, Malaysia, Philippine, Turkey, Saudi Arabia, UAE, Qatar