



Department of City Planning - Environmental Analysis Section

City Hall • 200 N. Spring Street, Room 750 • Los Angeles, CA 90012



Volume 4 of 9
Appendices H-1 through H-2 Part 1
DRAFT ENVIRONMENTAL IMPACT REPORT

WILSHIRE COMMUNITY PLAN AREA

Academy Museum of Motion Pictures Project

Case Number: ENV-2013-1531-EIR
State Clearinghouse Number: 2013051086

**THIS DOCUMENT COMPRISES THE FIRST PART OF THE ENVIRONMENTAL
IMPACT REPORT (EIR) FOR THE PROJECT DESCRIBED. THE FINAL EIR WILL
COMPRISE THE SECOND AND FINAL PART.**

Project Address: 6067 Wilshire Boulevard, Los Angeles, California 90036

Project Description: The proposed Academy Museum of Motion Pictures (“Project” or “Museum”) would involve rehabilitation and adaptive reuse of the historically significant May Company Building, and construction of a New Wing, which would require demolition of a 1946 Addition to the May Company Building. The Project would retain important historic features of the Original Building constructed in 1939, including rehabilitation of its primary façades, while retrofitting the building interior to accommodate Museum uses. The New Wing would be constructed on the north side of the Original Building and include a Museum entrance, a 42,300-square foot Sphere housing a state-of-the-art Main Theater with seating for up to 1,000 persons, a 10,000-square foot enclosed View Deck within the Sphere, pedestrian bridges linking the Sphere to the Original Building, and an outdoor Piazza.

Council District: 4, Tom LaBonge

APPLICANT:
Homewood Foundation

PREPARED BY:
Environmental Review Section
Los Angeles City Planning Department

August 2014

H-1: Methane Report

Prepared for

Homewood Foundation

8949 Wilshire Boulevard
Beverly Hills, California 90210

Methane Report

Academy Museum of Motion Pictures

Prepared by

Geosyntec 
consultants

10875 Rancho Bernardo Rd. Suite 200
San Diego, California 92127

Project Number SC0683

July 2014

TABLE OF CONTENTS

1.	INTRODUCTION	1
1.1	Purpose and Scope	1
1.2	Project Description	1
1.3	Regulatory Context.....	2
1.3.1	Cal/OSHA	2
1.3.2	City of Los Angeles	2
1.3.3	Regional Water Quality Control Board	3
1.3.4	City of Los Angeles, Industrial Waste Management Division	4
1.3.5	RWQCB and California Department of Resources, Recycling, and Recovery	4
1.4	Regulatory Oversight.....	5
1.4.1	Cal/OSHA	5
1.4.2	City of Los Angeles	5
1.4.3	LARWQCB.....	6
1.4.4	LAIWMD.....	6
1.4.5	RWQCB and CalRecycle.....	6
1.5	Report Organization	7
2.	EXISTING CONDITIONS	8
2.1	Geology	8
2.2	Groundwater	9
2.3	Historic Oil Production.....	10
2.4	Subsurface Gas Conditions.....	10
2.5	Adjacent Properties.....	12
3.	THRESHOLDS OF SIGNIFICANCE AND METHODOLOGY.....	13
3.1	Air Quality	14
3.2	Hazards and Hazardous Materials	14
3.3	Geology and Soils.....	14
4.	PROJECT DESIGN FEATURES.....	15
4.1	Construction Controls.....	16
4.2	Operational Controls.....	17

4.2.1	Original Building and Underground Utility Corridor	17
4.2.2	Paved Areas.....	19
4.3	Operations and Maintenance Plan	19
4.4	Emergency Plan.....	20
5.	IMPACT ANALYSIS	21
5.1	Construction.....	21
5.1.1	Original Building	21
5.1.2	New Wing	22
5.2	Operation	23
5.2.1	Original Building	23
5.2.2	New Wing	23
6.	REFERENCES	25

— List of Tables —

Table 1: Minimum Methane Mitigation Requirements City of Los Angeles Methane Zone

— List of Figures —

Figure 1: Site Vicinity

Figure 2: Methane Zones

Figure 3: Methane Mitigation System Details (I of II)

Figure 4: Methane Mitigation System Details (II of II)

1. INTRODUCTION

Geosyntec Consultants, Inc. (Geosyntec) has prepared this Methane Report (Report) on behalf of the Homewood Foundation (Homewood) in support of their proposed Academy Museum of Motion Pictures Project (Project) located at 6067 Wilshire Boulevard in Los Angeles, California (Site) (Figure 1). The Site is within the City of Los Angeles Methane Zone (LADBS, 2003); therefore, methane mitigation of the building is necessary during Project construction and operation (Figure 2).

1.1 Purpose and Scope

The purpose of this Report is to address subsurface gas related hazards and hazards arising from construction and operation of the gas mitigation system for the Environmental Impact Report (EIR) for the Project. A review and evaluation of the existing site conditions and methane mitigation regulatory standards applicability is provided. The evaluation focuses on the potential impacts of the subsurface gas conditions on construction and operation of the Project and methods to mitigate the impacts. Additionally, the evaluation discusses the potential impacts of construction and operation of the gas mitigation system.

1.2 Project Description

The Project would involve rehabilitation and adaptive reuse of the Original May Company Building constructed in 1939 (“Original Building”), and construction of a new wing (“New Wing”) and an at-grade piazza (“Piazza”). The Museum would be dedicated to films and filmmaking and would include permanent and changing exhibition space; three theaters with a combined seating capacity of up to approximately 1,350; banquet and conference space with a maximum occupancy of approximately 1,200 persons; an approximately 4,000-square-foot café (“Museum Café”) with seating for up to approximately 150 persons; an approximately 5,000-square-foot store (“Museum Store”); and ancillary spaces including administrative offices, educational spaces, exhibit preparation, a conservation laboratory, and maintenance and receiving areas. Parking would be provided through joint use of existing LACMA parking facilities and existing off-site parking facilities in the immediate vicinity.

The design concept would retain important historic features of the Original Building, including rehabilitation of its primary façades and seismic reinforcement, while retrofitting the building interior to accommodate Museum uses. Circulation elements, including escalators, elevators, and potentially stairs would be accommodated within

the Original Building in the area along the North façade where the above-grade portion 1946 Addition would be removed. Removal of the above-grade portion of the 1946 Addition would allow construction of the approximately 42,300-square-foot New Wing and Piazza. The New Wing would include a Museum entrance; a spherical structure (“Sphere”) housing a state-of-the-art theater with seating for up to 1,000 persons (“Main Theater”); an approximately 10,000-square-foot enclosed view deck (“View Deck”) within the Sphere; and pedestrian bridges linking the Sphere to the Original Building. Construction of the New Wing would also require a utility corridor between the Original Building and the Sphere. Total developed floor area (“Floor Area”) on the Project Site at buildout would be up to approximately 208,000 square feet. The outdoor Piazza would be constructed to the north of the Original Building and the Museum’s northern entrance including the areas beneath and surrounding the Sphere. The Piazza would provide public access to the Museum and LACMA Campus, Museum Café and other seating, and accommodate Museum and Academy programs and special events.

1.3 Regulatory Context

1.3.1 Cal/OSHA

Federal occupational safety and health regulations contain provisions with respect to hazardous materials management. The applicable federal law is the Occupational Safety and Health Act (OSHA) of 1970 as amended (29 U.S.C., Sections 651-678; 29 CFR 1910). Federal OSHA requirements are designed to promote worker safety, worker training, and worker right-to-know. OSHA establishes regulatory requirements primarily by promulgating occupational safety and health standards. These standards establish permissible exposure limits (PELs) for a number of air contaminants (29 CFR sec. 1910.1000). These PELs define the amount of hazardous airborne chemicals to which an employee safely could be exposed over specific periods of time. When administrative or engineering controls cannot achieve compliance with PELs, protective equipment or other protective measures must be used.

1.3.2 City of Los Angeles

The Methane Zone and Methane Zone Buffer were plotted by the Los Angeles Department of Public Works (LADPW) using information and data provided by the Division of Oil, Gas and Geothermal Resources, Department of Conservation, State of California, City of Los Angeles Department of Environmental Affairs, Department of Building and Safety and the Fire Department to show areas within the City of Los Angeles where a potential hazard of methane gas exists. The City of Los Angeles

regulates development within the designated Methane Zone and Methane Zone Buffer to control methane intrusion into buildings under Division 71 of Article 1, Chapter IX of the Los Angeles Municipal Code (Methane Code, LAMC 91.7107). More controls are required for developments within the Methane Zone than the Methane Zone Buffer.

Mitigation requirements within the Methane Zone and Methane Buffer Zone are further refined at the Site Design Level for a given project, which is determined through Site Testing as shown in Tables 1 and 2 at the end of this report. Site Testing is performed in accordance with the Methane Mitigation Standards and identifies the depth to groundwater, the design methane concentration (defined as the highest concentration of methane gas found during site testing), and the design methane pressure (defined as the highest pressure of methane gas found during site testing) through the installation and measurement of gas probes. Sites with lower concentrations and pressures of methane have fewer mitigation requirements than higher concentrations and pressures of methane. A site may be exempt from Site Testing if the development is designed to meet the requirements of Site Design Level V.

New development, such as the utility corridor, must implement the mitigation requirements identified in Tables 1 and 2 within the Methane Zone and Methane Zone Buffer, respectively, unless exempted by the LADBS. Existing buildings within the Methane Zone, such as the Original Building on the Project Site, are required to comply with the Methane Code when required by Division 34 of the Los Angeles Municipal Code. Division 34 requires an entire building or structure to comply with the current code when the aggregate value of the additions, alterations, repairs, or rehabilitation of the existing portion is in excess of 50 percent of the replacement value of the building or structure (LAMC Building Code 91.3404.1.1). Permits may be withheld on a development unless the methane requirements are implemented (see Section 1.4.2, below)

1.3.3 Regional Water Quality Control Board

The City of Los Angeles storm water discharges operate under Municipal Separate Storm Sewer System (MS4) Order No. R4-2012-0175 for MS4 Discharges within the Coastal Watersheds of Los Angeles County. Under MS4 Order No. R4-2012-0175, the Los Angeles Regional Water Quality Control Board (LARWQCB) issues National Pollutant Discharge Elimination System (NPDES) permits when groundwater from construction or project dewatering is discharged to the storm drain system. Construction dewatering operations and long-term sub-slab dewatering operations will be permitted under General NPDES permit No. CAG994004: Waste Discharge Requirements for Discharges of Groundwater from Construction and Project Dewatering to Surface

Waters in Coastal Watersheds of Los Angeles and Ventura Counties (Order No. R4-2013-0095) if groundwater is discharged to the storm drain system. Dewatered groundwater discharged to the sanitary sewer system is permitted in accordance with Section 1.3.4 below.

1.3.4 City of Los Angeles, Industrial Waste Management Division

The City of Los Angeles, Bureau of Sanitation, Industrial Waste Management Division (LAIWMD) issues Industrial Waste Water Discharge (IWW) Permits for any water bearing waste other than domestic wastewater or of wastewater generated from household type operations performed at commercial establishments for or to support commercial purposes discharged to the sanitary sewer. Treated groundwater discharge would be classified as water bearing waste due to impacts as identified in the Project Hydrology Report (KPFF, 2014) and Project Geotechnical Report (Shannon & Wilson, 2014).

1.3.5 RWQCB and California Department of Resources, Recycling, and Recovery

Nonhazardous waste Disposal Facilities are regulated jointly by the RWQCB and California Department of Resources, Recycling, and Recovery's (CalRecycle) Waste Discharge Requirements (WDR) Program under California Code of Regulation, Title 27 (27 CCR) Division 2, Solid Waste. Disposal facilities are classified according to the types of waste they are permitted to accept. Regulations defining petroleum impacted soils are listed under California Water Code section 13050. Regional Water Quality Board Order No. R4-2011-0052 establishes region-wide waste acceptance requirements for the disposal or on-site use of contaminated soils at municipal solid waste landfills (Shannon & Wilson, 2014). Class III landfills accept nonhazardous solid waste, Class II landfills accept designated wastes, and Class I landfills accept hazardous waste; disposal of specific types of waste are further designated in each disposal facility's WDR.

Disposal of impacted soil requires analytical testing in accordance with the disposal facility's WDRs including, but not limited to, total petroleum hydrocarbons (TPH), volatile organic compounds (VOCs), California Administrative Manual (CAM) metals, and, if applicable, Soluble Threshold Limit Concentration (STLC) and Toxicity Characteristic Leaching Procedure (TCLP). Analytical testing will identify if the impacted soil is non-hazardous, California hazardous non-Resource Conservation and Recovery Act (RCRA) (Cal-Haz Non-RCRA), or hazardous RCRA waste. If waste is

Cal-Haz Non-RCRA or hazardous waste, additional manifest documentation is required for transport and disposal through the United States Environmental Protection Agency (USEPA).

1.4 Regulatory Oversight

1.4.1 Cal/OSHA

OSHA can delegate its authority to administer the act to states that have developed a state plan with provisions at least as stringent as those provided by OSHA. California is a delegated state for federal OSHA purposes. The Cal/OSHA program (codified in CCR, Title 8, and in the Labor Code Secs. 6300-6711) is administered and enforced by the Division of Occupational Safety and Health, a unit of the California Department of Industrial Relations.

Cal/OSHA provides regulations of a work area when explosion hazards are present. Specifically, the work environment shall be regulated as follows:

- Ventilation in enclosed places must be sufficient to prevent flammable vapor or gas concentrations from exceeding 25% of the LEL; and
- No source of ignition is permitted indoors or outdoors where vapor or gas concentrations may reasonably be expected to exceed 25% of the LEL (Cal/OSHA, 2011).

1.4.2 City of Los Angeles

The Methane Code is enforced by the Los Angeles Department of Building Safety (LADBS) and Los Angeles Fire Department (LAFD). LADBS reviews the Site Test Data, provides plan checking and approval for structural, electrical and mechanical systems, and issues the building permit for the Methane Mitigation System. LADBS has the ability to withhold building permits until plans showing adequate protection against methane are provided (LAMC Building Code Section 91.106.4.1). The Methane Code also requires development of a new Emergency Plan for all buildings with a gas detection system (LAMC Building Code 91.7107).

LAFD approves all devices, components, and equipment installed in any methane detection system as set forth in Fire Prevention Bureau (F. P. 8.) Requirement No. 71; LAFD approval for these components is received prior to LADBS approval. LAFD also

reviews required remedial actions and evaluates abandoned oil wells encountered during construction.

1.4.3 LARWQCB

The NPDES permits are enforced by the Los Angeles RWQCB (LARWQCB). To discharge dewatered groundwater to the storm drain system, a notice of intent (NOI) will be submitted and the applicability of the discharge will be reviewed by the LARWQCB Executive Officer. If approved, a written determination of eligibility for coverage under the general permit will be issued (Order No. R4-2013-0095).

With the NOI, a feasibility study on conservation, reuse, and/or alternative disposal methods of the wastewater will be presented. If alternative disposal methods are infeasible, a representative sample of groundwater to be discharged must be analyzed and shown to be within the allowable limits of the permit. If treatment is required, the NOI permit application will need to include a description of the treatment system, the types of treatment chemicals (if any), a flow diagram of the influent to the discharge point, and a description of the preventative maintenance procedures and treatment schedule for the system. An enrollment fee must be submitted with the NOI permit application as well (Order No. R4-2013-0095).

1.4.4 LAIWMD

The LAIWMD will oversee groundwater discharges to the sanitary sewer system through the IWWD Permit if the flows are greater than 200 gallons per day and/or require treatment prior to discharge. The details of the waste water flow and, if necessary, treatment with diagrams and schematics will be provided to the LAIWMD on the IWWD Permit application. Upon receipt of the permit application, an industrial waste inspector will inspect the facility, verify that the information provided in the permit application is complete and accurate, and identify all wastewater generating processes, methods of wastewater conveyance, and pretreatment systems, if any. Permit applications are reviewed and processed by IWMD staff to establish discharge limitations, monitoring and reporting requirements (IWMD, 2013).

1.4.5 RWQCB and CalRecycle

The LARWQCB and Los Angeles Local Enforcement Agency (LEA): the Department of Public Health (DPH, on behalf of CalRecycle), and the Department of Toxic Substances Control (DTSC, on behalf of USEPA) will oversee Cal-Haz Non-RCRA and hazardous waste manifesting and disposal. Non-hazardous impacted soil disposal will be tracked with a non-hazardous waste manifest and monitored by the disposal facility

including review of analytical data. Agency non-hazardous waste reporting is the responsibility of the disposal facility.

1.5 Report Organization

This document is organized into the following sections:

- Section 2 – “Existing Conditions,” describes the history and physical characteristics of the site;
- Section 3 – “Threshold of Significance and Methodology,” identifies the thresholds of significance addressing the potential for impacts during construction and operation. The methodology for assessment of potential impacts including actionable concentrations for mitigation and detection;
- Section 4 – “Project Design Features,” provides an overview of the methane mitigation system proposed by Homewood to minimize impacts from subsurface gases including the general design and performance standards, system integration into the existing system, the review and approval process, operations and maintenance of the system, and procedures during construction to prevent gas-related explosion and toxic issues;
- Section 5 – “Impact Analysis,” defines the Project’s potential for impacts assuming the proposed Project Design Features are implemented.
- Section 6 – “References,” presents the references consulted in the preparation of this report.

2. EXISTING CONDITIONS

2.1 Geology

The Site is located near the boundary of the Peninsular Ranges and Transverse Ranges physiographic provinces, within the northwestern portion of the Los Angeles Basin, just south of the Santa Monica Mountains. The dominant structural features of the Peninsular Ranges are northwesterly trending ranges, valleys, and fault zones such as the nearby Newport-Inglewood fault zone located approximately 2.5 miles west of the site. In contrast, the Transverse Ranges are characterized by east-west trending structural features such as the Santa Monica Mountains and the Hollywood and Santa Monica faults located approximately 2.7 and 3.8 miles north of the site, respectively (Metro, 2010).

The Los Angeles Basin is an elongated northwest trending, sediment-filled structural trough. At the surface the basin is low relief, alluvial coastal plain that generally slopes toward the Pacific Ocean. Surficial geology at the site has been characterized as Quaternary alluvial sediments shed from the south flank of the Santa Monica Mountains to the north.

Based on previous borings drilled in the site vicinity, the site area is underlain by a sequence of sedimentary units extending greater than 200 feet in depth, including the following units:

- Artificial Fill: Variable thicknesses of pavement, foundations, and engineered fill soil occur throughout the site vicinity. Fill thicknesses encountered in geotechnical borings ranged from approximately one to eight feet and was composed of variable proportions of clay, gravelly sand, clayey sand, and silty sand (Shannon & Wilson, 2013).
- Younger Alluvium (Holocene): Poorly consolidated, interlayered silts, clays, and silty sands with some sand layers and gravel.
- Older Alluvium (Late Pleistocene): Non-marine and marine sediments.
- Lakewood Formation (Pleistocene): Interbedded silts and clays, sands, silty sands, and some clayey sand layers.

- San Pedro Formation (Pleistocene): Fine-grained sand and silty sand with few interbeds of medium to coarse-grained sand and some local silt layers, and some asphaltic silt layers.
- Fernando Formation (Pliocene): Predominantly massive siltstone and claystone with few sandstone interbeds and thin asphaltic seams.
- Puente Formation (Miocene): Massive siltstone and intervals of claystone interbedded with thin sandstone and siltstone laminae.

Tar-impacted soils and bedrock occur in the site vicinity within the Older Alluvium, Lakewood, San Pedro, and Fernando Formations, as shallow as 10 to 25 feet below ground surface (AMEC, 2011).

2.2 Groundwater

The site is situated within the Central Sub-basin of the Coastal Plain of the Los Angeles Groundwater Basin. Groundwater in the Central Basin occurs at relatively shallow depths within the recent and older alluvium. Additionally, groundwater occurs within sands and gravels of several aquifers of the Pleistocene age Lakewood and San Pedro Formations. Confined groundwater occurs in the deeper aquifers of these formations (California Department of Water Resources, 2004).

Geotechnical investigation performed at the site in 2013 indicated that groundwater was generally encountered at approximately 10 feet below ground surface, and referenced the State Water Resources Control Board's GeoTracker Groundwater Ambient Monitoring and Assessment (GAMA) Program which indicated that depth to groundwater is variable but generally occurs from 10 to 15 feet below ground surface with flow directions ranging from southwesterly to southeasterly (Shannon & Wilson, 2014). However, groundwater was encountered as shallow as 5.5 feet below ground surface during construction activities at the LACMA Campus (VB&B, 2005). For construction design purposes, groundwater was assumed at a depth of 10 feet below ground surface (Shannon & Wilson, 2014). Based on these data, relatively shallow groundwater at the site may be encountered during construction activities and should be considered during design, and groundwater likely contains dissolved methane and hydrogen sulfide which should be evaluated for handling and disposal. Additionally, the variable depth to groundwater may influence conditions in the vadose zone (the unsaturated zone between the ground surface and top of groundwater) at the site which

could affect the migration of subsurface gases, and should be considered during design and construction.

2.3 Historic Oil Production

The Los Angeles Basin is a prolific petroleum basin with a history of petroleum production since the late 1800s. Significant oil exploration and extraction has occurred in the site vicinity, including the Salt Lake Oil Field beneath the site and to the north, and the South Salt Lake Oil Field, just south of the site (DOGGR, 1998). The productive region of the Salt Lake Oil Field has been estimated to be three miles long by one mile across, and the smaller South Salt Lake Soil Field has been estimated to be approximately one mile long by 1,000 feet across. Several producing horizons occur within the oil fields, with the shallowest estimated to be approximately 1,000 feet below ground surface. Within the Salt Lake Oil Field are the La Brea Tar Pits (approximately 1,000 feet east of the site). The La Brea Tar Pits are a group of surficial tar/asphaltum deposits within Hancock Park formed by the upward migration of hydrocarbons from the underlying Salt Lake Oil Field through fractures, including the 6th Street Fault (Page Museum, 2013). As crude oil migrates upward the lighter fractions of hydrocarbons evaporate or biodegrade which results in the viscous, residual heavy oil fractions observed at the La Brea Tar Pits.

Based on a review of the State of California Division of Oil, Gas and Geothermal Resources (DOGGR) Online Mapping System, five plugged or idle oil wells are located within 1,000 feet of the site (DOGGR, 2013). Active oil wells are not known to exist within 1,000 feet of the site.

2.4 Subsurface Gas Conditions

The subsurface conditions in the site vicinity are known to include naturally-occurring methane and hydrogen sulfide gas associated with underlying and nearby oil and gas fields. The natural biodegradation of hydrocarbons results in the production of methane gas (methanogenesis) and other gases such as hydrogen sulfide which migrate vertically through the subsurface and may accumulate beneath pavement, foundations, or other less permeable barriers (Metro, 2010). Methane and hydrogen sulfide gas, hereinafter referred to collectively as “gas”, are considered hazardous gases due to their explosive properties, and hydrogen sulfide is also toxic.

Methane is extremely flammable, may form explosive mixtures with air, and can act as an asphyxiant at concentrations above the upper explosive limit (UEL) (WDHS, 2010)

as it displaces oxygen in an enclosed space. The lower explosive limit (LEL) and UEL for methane are 5 percent and 15 percent by volume, respectively (Matheson, 2013). Methane is odorless, colorless, and is explosive when present in concentrations between its LEL and UEL (Matheson Gas, 2001). Methane does not have permissible exposure limits (PELs) or short-term exposure limits (STELs) established by Cal/OSHA.

Hydrogen sulfide gas is flammable, may form explosive mixtures with air, and is considered a broad-spectrum poison primarily affecting the nervous system. The LEL and UEL for hydrogen sulfide gas are 4 percent and 46 percent by volume, respectively (ATSDR, 2007).

Hydrogen sulfide is a toxic, flammable, and colorless gas that poses an immediate fire and explosion hazard when mixed with air at concentrations between 4 and 46 percent, its LEL and UEL, respectively (ATSDR, 2007). Continuous exposure to hydrogen sulfide in low concentrations may cause loss of smell, dizziness, headache, nausea, and respiratory tract irritation. At higher concentrations, hydrogen sulfide can cause death (ATSDR, 2006). Hydrogen sulfide gas has a distinct “rotten-egg” smell and in the area occurs in localized zones of soil and groundwater. Hydrogen sulfide can be detected by odor at concentrations as low as 0.5 parts per billion (ppb) (ATSDR, 2007).

Worker exposure to hydrogen sulfide is regulated by Cal/OSHA. Cal/OSHA provides PEL and STEL for chemical contaminants. The PEL is the 8-hour time weighted average (TWA); typically a one-type maximum concentration within the 8-hour period is also provided (also known as the ceiling concentration). The STEL is the acceptable average exposure over a short period of time, usually 15 minutes as long as the TWA is not exceeded. The PEL for hydrogen sulfide is 10 parts per million (ppm) while the ceiling concentration is 50 ppm. Cal/OSHA established 15 ppm as hydrogen sulfide’s STEL (Cal/OSHA, 2013).

These potentially hazardous gases can seep through soil, fractures, faults, excavations, and other conduits and accumulate in hazardous concentrations beneath foundations and within structures in poorly ventilated spaces. The Project Site is located within the City of Los Angeles-designated High Potential Methane Zone, which was created following the March 24th, 1985 explosion and investigation at the former Ross Dress for Less store located at the southeast corner of Fairfax Avenue and 3rd Street, approximately ½-mile north of the Project site. The Ross Dress for Less explosion was determined to be the result of the accumulation of methane gas in an interior room which ignited causing significant damage to the structure and injury to 23 people (Meehan, et al, 1992). Subsequently, the City of Los Angeles designated the approximately 400 blocks

overlying the Salt Lake Oil Field as a High Potential Methane Zone (Ordinance No. 191552, 1986) and requires structures to include a methane mitigation system potentially consisting of de-watering system, sub-slab vent system, impervious membrane, gas detection system, mechanical ventilation, alarm system and control panel, trench dams, cable or conduit seal fittings, and/or additional vent risers.

Historic methane concentrations reported in the Los Angeles County Museum of Art (LACMA) and La Brea Tar Pits area have been reported as high as 100 percent (1,000,000 ppmv) while hydrogen sulfide levels have been as high as 1.0 percent (10,000 ppmv) (Parsons, 2013).

2.5 Adjacent Properties

Subsequent to the adoption of Ordinance No. 161552 in to the Los Angeles Municipal Code in August 1986, which required mitigation for methane gas intrusion into buildings located in the Fairfax area, numerous methane mitigation systems have been designed for buildings surrounding the Site. These include LACMA located at 5905 Wilshire Blvd, the Petersen Automotive Museum located at 6060 Wilshire Boulevard, and the 16 story “Miracle Mile” office complex located at 6100 Wilshire among other mixed use retail, restaurant, residential and office complexes in the area. The exiting May Company Building does not have any methane mitigation and/or detection system(s) in place.

In addition to the developments listed above, the Los Angeles County Metropolitan Transportation Authority (Metro) will be extending the existing Purple Line subway west beneath Wilshire Blvd. (Westside Extension Project) with one of the planned stations located at the intersection Wilshire Blvd. and Fairfax Ave. (Metro, 2012). As part of the Westside Extension Project, Metro has proposed a methane mitigation and gas detection system consisting of a methane barrier, ventilation and alarm systems similar to those proposed for the Project. Details of the Project’s proposed methane mitigation system are discussed in Section 4.

3. THRESHOLDS OF SIGNIFICANCE AND METHODOLOGY

The following sections describe the screening criteria, thresholds of significance, and methodology to assess the potential gas impacts to the Project. As discussed in Section 2.4, Subsurface Gas Conditions, high concentrations of methane and hydrogen sulfide are present in the vicinity of and beneath the Site.

The subsurface gas impact on the Project was evaluated based on applicable sections of the California Environmental Quality Act (CEQA) Appendix G checklist (AEP, 2012) and City of Los Angeles CEQA Thresholds Guide (City of Los Angeles, 2006). The CEQA Appendix G checklist questions evaluated and the *screening criteria* identified through the City of Los Angeles CEQA Threshold Guide are as follows:

- III.b. Air Quality: Would the project violate any air quality standard or contribute substantially to an existing or projected air quality violation?
 - *Would the project use, store, or process carcinogenic or non-carcinogenic toxic air contaminants which could result in airborne emissions?*
- III.e. Air Quality: Would the project create objectionable odors affecting a substantial number of people?
- VII.b. Hazards and Hazardous Materials: Would the project create significant hazards to the public or the environment through reasonably foreseeable upset and accident conditions involving the release of hazardous materials into the environment?
 - *Would the project use or manage hazardous or potentially hazardous or explosive substances (including, but not limited to, oil, pesticides, chemicals, or radiation)?*
 - *Would the project require a new or revised risk management plan, emergency response, or emergency evacuation plan?*
- VI. Geology and Soils
 - *Is the project located in an area susceptible to unusual geologic hazards considering the following: designation on official maps and databases; past episodes on-site or in the surrounding area; and physical properties of the site, including the topography, soil, or underlying bedrock (including thickness of bedrock and soil compressibility, strength, moisture content, and distribution)?*

The following sections describe the methodology to determine Project impacts.

3.1 Air Quality

The potential for air quality impacts from methane and hydrogen sulfide on the Project Site was analyzed by evaluating the potential for release of these gases during Project construction, including construction activities for the Original Building and new development, and Project operation. The potential for odors to affect nearby land uses or members of the general public during construction was also evaluated.

3.2 Hazards and Hazardous Materials

The potential for risk of upset associated with the release of hazardous materials into the environment, and the potential for impacts on risk management, emergency response, or emergency evacuation plans, was analyzed by evaluating the potential for the accumulation of toxic and/or flammable gases in confined spaces during Project construction and operation, within the Original Building and new development (e.g., in excavation pits and trenches, inside existing and proposed buildings, and beneath proposed hardscape features).

3.3 Geology and Soils

Project impacts related to Geology and Soils evaluated the properties of the rock units and soils underlying the Project Site to determine the potential for the Project's susceptibility to naturally-occurring methane and hydrogen sulfide gas hazards. In the areas near the Project, methane can reach concentration of 90 to 100 percent by volume (pbv) (900,000 to 1,000,000 ppmv) with hydrogen sulfide concentrations as high as 1.0 pbv or 10,000 ppmv. Methane gas pressure in the Project vicinity has been reported up to 844 inches of water column, equivalent to water pressure in the area (Metro, 2012).

4. PROJECT DESIGN FEATURES

In accordance with the LAMC, when the aggregate value of a building modification is in excess of 50 percent of the building replacement value, the building must be brought into conformance with the Methane Code (LAMC 91.3404.1.1).

Per the Methane Code and as shown in Table 1, the Original Building, remaining below-grade portions of the 1946 Addition, and underground utility corridor are required to have the following:

- Dewatering system
- Passive system
 - Impervious membrane
 - Sub-slab vent system
 - Perforated horizontal pipe within a gravel trench
 - Gravel blanket
 - Vent Risers
- Active system
 - Sub-slab vent system: mechanical extraction
 - Lowest occupied space:
 - Gas detection system
 - Mechanical ventilation
 - Alarm system
 - Control panel
- Miscellaneous components
 - Trench dam
 - Conduit or cable seal fitting

The Sphere portion of the New Wing will connect to the underground utility corridor and will be elevated above the Piazza; therefore, methane mitigation will be achieved by the methane mitigation system in-place for the underground utility corridor.

The approximately 45,000-square-foot (sf) Piazza is regulated under the Paved Areas requirements of the Methane Code. The Piazza is required to be vented with paving vents spaced no farther apart than every 100 feet, or, if vents are not used, unpaved landscaped areas are required immediately adjacent to the building exterior wall and must be a minimum of 2 feet wide and extend along at least 80 percent of the building perimeter.

4.1 Construction Controls

During Original Building upgrades and New Wing construction at the Project site, controls will be in place to mitigate the effects of subsurface gases and impacted soil and groundwater on workers and the public. During construction, the following will be implemented:

- Gas monitoring devices will be present to alert workers to elevated gas concentrations when basement or subsurface soil disturbing work is being performed.
- Contingency procedures will be in place if elevated gas concentrations are detected such as the mandatory use of personal protective equipment (PPE) use, evacuating the area, and/or increasing ventilation within immediate work area where the elevated concentrations are detected.
- Workers will be trained to identify exposure symptoms and implement alarm response actions.
- The groundwater elevation will be lowered using dewatering wells prior to excavation below groundwater. Groundwater collected will be treated and discharged in accordance with Los Angeles Regional Water Quality Control Board (LARWQCB) requirements as presented in the Hydrology Report (KPF, 2014).
- Soil and groundwater exposed during excavations will be minimized to reduce the surface area which could off-gas. This will be done by staggering exposed demolition areas.
- Impacted soil and groundwater handling will be minimized to reduce worker exposure.
- Soil removed as part of methane system installation will be sampled and tested for disposal in a timely manner. A Soil Management Plan will be developed to address the site-specific testing parameters and sampling frequency. Anticipated testing includes total petroleum hydrocarbons (TPH) and TPH-diesel, volatile organic compounds (VOCs), and CAM-17 metals. If metals are elevated, STLC and TCLP testing may be performed. If soil is stockpiled prior to disposal, it will be managed in accordance with the project's Storm Water Pollution Prevention

Plan (SWPPP). Soil will be disposed of at a facility permitted to accept the characterized soil.

- Distance between the public and excavation activities will allow for gas dilution; therefore, exclusion zone fencing will be established to limit public access.
- Health and Safety Plan (HASP) development which will describe the work activities and hazards associated with each work activity. Hazard mitigation will be presented in the HASP to limit construction risks to workers. The HASP will have emergency contact numbers, maps to the nearest hospital, gas monitoring action levels, gas response actions, allowable worker exposure times, and mandatory PPE requirements. The HASP will be signed by all workers onsite to demonstrate their understanding of the construction risks.

These controls will reduce to a less than significant level the risk associated with hazardous gas during Project implementation.

4.2 Operational Controls

The operational controls will consist of a methane mitigation system. The system will comprise a combination of the passive and active systems described in the Methane Code for Site Design Level V (Table 1). The methane mitigation system, which will mitigate both methane and hydrogen sulfide, is described in greater detail below.

4.2.1 Original Building and Underground Utility Corridor

The Original Building mitigation system will be implemented within the entire basement of the Original Building including the 1946 Addition foundation to be left in place. In addition, these controls will be implemented for the underground utility corridor.

4.2.1.1 *Below Concrete Basement Topping Slab*

Beneath the concrete basement topping slab, the methane mitigation system will consist of a: (1) dewatering system; (2) sub-slab ventilation system; and (3) impervious membrane. Unless a waiver is granted by LADBS, a dewatering system is necessary due to the presence of groundwater within 12-inches of the proposed sub-slab ventilation system. The dewatering system will consist of perforated pipes spaced no greater than 50-feet apart and sloped to a collection sump. Water collected in the sump will be discharged in accordance with LAIWMD IWW permit guidelines including

pretreatment, if necessary, to achieve sanitary sewer discharge standards. The IWWDP Permits will dictate the treatment standards, operation, and reporting criteria for the dewatering system.

The series of perforated pipes will also be incorporated into the sub-slab ventilation system as the horizontal perforated gas extraction pipes (Figure 3, Details 1, 2, and 3). The pipes will be installed within a trench and surrounded on all sides by a minimum of 4 inches of gravel (Figure 3, Detail 1). Above the pipes, a gravel blanket will collect gas beneath the impervious membrane.

The perforated pipes will be connected to solid vent risers which will vent accumulated gas to the atmosphere (Figure 3, Details 4 and 5). Within the solid vent risers, gas detectors will monitor potentially explosive gas concentrations and activate the sub-slab ventilation system when concentrations are greater than 75 percent of the LEL. When activated, the ventilation system will be capable of 3 air exchanges per hour.

The impervious membrane will serve as both the waterproofing and gas barrier. The membrane will be made of material approved by the City of Los Angeles. The impervious membrane will be terminated at the footings with cold and/or expansion joints to prevent migration through floors and footing junctions as shown on Details 6 and 7 on Figure 3 and Detail 8 on Figure 4. Penetrations through the floor slab will have a membrane boot while conduit trenches will be dammed to prevent gas migration (Figure 4, Detail 9 and Figure 4, Details 10 and 11, respectively).

Two layers of impervious membrane will be installed beneath elevator and sump pits. Existing basement walls include a waterproofing system that will serve as an impervious membrane.

The Original Building has an approximately 1.9-foot thick concrete mat slab foundation beneath the concrete basement topping slab, which is located between 1 and 4 feet above the mat slab. The space between the concrete mat slab foundation and concrete basement topping slab is filled with soil. The methane mitigation system will be incorporated into the existing building with the waterproofing system. The existing concrete basement topping slab will be removed as well as a minimum of 4-inches of the underlying soil. Trenches will be excavated within the soil for the dewatering and gas venting horizontal pipes. The excavated areas will be backfilled with gravel, overlain by the impermeable membrane, with a new concrete basement topping slab installed above.

4.2.1.2 Above Concrete Basement Topping Slab

The above concrete basement topping slab methane mitigation controls in the lowest occupied space will include explosive gas detectors, mechanical ventilation, and an alarm system. Explosive gas detectors will be placed at key locations within the lowest occupied space at the frequency specified in the Methane Code. Mechanical ventilation will operate continuously at a rate of 1 air exchange per hour with 24 hour of back-up power provided. If gas is detected at a concentration of greater than 25 percent of LEL, an audible and visual alarm will be triggered alerting occupants of the building to evacuate.

4.2.2 Paved Areas

Paved areas exceeding 5,000 square feet and within 15 feet of any building's exterior walls will require venting. The proposed Piazza north of the Original Building will meet this criterion. The Piazza area will be vented by implementing Detail 12 on Figure 4 with vents spaced no more than 100 feet apart or by installing 2 foot wide landscaped areas immediately adjacent to the building's exterior walls covering at least 80% of the building perimeter.

4.3 Operations and Maintenance Plan

An Operations and Maintenance (“O&M”) Plan will be developed for the methane mitigation systems. The O&M Plan will incorporate the manufacturers’ maintenance and service procedures for each gas detection and mechanical ventilation system as well as Fire Prevention Bureau Requirement No. 71, Fire Chef’s Regulation 4, Section 4J (Fire Regulations) which provides a systems certification checklist and alarm testing requirements.

The Fire Regulations require verification that the gas detection system and all associated components are maintained in proper operating condition. It requires annual inspection of the control panels, backup power, alarms, sensors, signage, and ventilation (LAFD, 2006). These components are inspected for compliance with their design intent by a person with a valid Certificate of Fitness for Gas Detection Systems as set forth in Los Angeles Municipal Code Section 57.06.01 (LAMC Section 91.7106).

Typical elements to be included with the O&M Plan will be regular calibration of the gas detection sensors, testing of the high-level alarms, and subsequent evaluation of alarm-triggered responses. Calibration of the sensors will be performed at a minimum

as recommended by the manufacturer. More frequent calibration may be necessary if sensor drift is identified.

Longer-term maintenance of the methane mitigation system will include evaluation of the horizontal gas extraction pipes and impervious membrane if subfloor work is performed which affects the impervious membrane and/or piping. Repairs to the pipes and impervious membrane will be in accordance with the Project Specifications to be prepared at a later date in anticipation of construction.

4.4 Emergency Plan

In accordance with the Methane Code, an Emergency Plan will be developed to address emergency situations resulting from gas detections. The Emergency Plan will identify the responsible individual for interfacing with LAFD in the establishment, implementation, and maintenance of the Emergency Plan. Conspicuous postings of the LAFD phone number and emergency plan procedures in locations designated by LAFD will be outlined in the Emergency Plan. The Emergency Plan will be approved by LAFD.

5. IMPACT ANALYSIS

5.1 Construction

Subsurface gases and impacted soil and groundwater will affect the Project during upgrading and renovation of the Original Building and New Wing construction.

5.1.1 Original Building

During excavation and construction, hydrogen sulfide and methane gas emissions may be generated and impacted soil and groundwater may be exposed. Hydrogen sulfide and methane gases are hazardous and explosive when allowed to accumulate. During construction-related excavation, hydrogen sulfide can accumulate in low-lying parts of trenches or pits. During Project operation, methane can accumulate within confined low-lying spaces such as basements where it can be trapped by overhead ceilings, and hydrogen sulfide can accumulate on the floors. Where such spaces are entirely enclosed, there is no natural ventilation to remove or dilute gases that accumulate. Impacted soil and groundwater may result in health and safety issues for site workers and the public due to the presence of hydrocarbons, metals, and/or VOCs. Further, uncontrolled releases of impacted soil and groundwater may spread impacts to areas off-site.

Workers and the public may be exposed to elevated gas levels and impacted soil and groundwater during demolition of the existing building concrete basement topping slab, excavation, installation of the gas-imperious membrane system, demolition of the 1946 Addition, and utility corridor trenching.

Within the Original Building basement, the existing 4-inch concrete basement topping slab will be demolished to allow installation of waterproofing and gas mitigation system features. Workers within the basement may be impacted by gas migration and impacted soil and groundwater prior to installation of the gas mitigation system.

If allowed to migrate and accumulate, methane concentrations may reach the explosive limits. Presence of a spark or flame will trigger an explosion if methane is within its explosive limits. The presence of hydrogen sulfide will result in odor issues at low concentrations. If allowed to accumulate without ventilation, higher concentrations of hydrogen sulfide may result in illness and even death of workers.

Impacted soil and groundwater exposure may result in illness and injury depending on the constituents of concern and their concentrations. Constituents of concern in soil and

groundwater are anticipated to be TPH, metals, and VOCs. The site specific HASP will identify minimization of risk associated with soil and groundwater handling. Soil and groundwater will be handled, treated, and/or disposed in accordance with the Soil Management Plan, in a timely manner to minimize worker and public exposure. Additionally, soil and groundwater may off-gas methane and hydrogen sulfide resulting in the hazards and health concerns discussed previously for these gases.

Implementation of Construction Control Project Design Features, as specified in Chapter 4, Section 4.1, will reduce hazards associated with construction in the Original Building to less than significant.

5.1.2 New Wing

During demolition of the above-grade portions of the 1946 Addition as well as excavation of the utility corridor between the Original Building and the New Wing, soil and groundwater may be exposed. At this time, workers and the public may be exposed to soil and groundwater off-gassing, including odorous hydrogen sulfide, until the waterproofing and gas mitigation system is installed and the excavation backfilled. Additionally, there may be worker health risks associated with handling of impacted soil and groundwater.

Construction of the New Wing will not likely result in accumulation of methane gas, since methane gas rises and ceiling barriers would not be present to trap the gas. The presence of hydrogen sulfide will result in odors at low concentrations which may be noticeable to the public in the vicinity of the Project. Due to hydrogen sulfide's propensity to accumulate in low lying areas, it is more likely to accumulate within excavated trenches and basements. If allowed to accumulate without ventilation, higher concentrations of hydrogen sulfide may result in illness and even death of workers. Minimal worker exposure to impacted soil and groundwater through handling is anticipated due to the use of PPE and timely disposal of soil and groundwater offsite.

Implementation of Construction Control Project Design Features, as specified in Chapter 4, Section 4.1, will reduce hazards associated with construction in the New Wing to less than significant.

5.2 Operation

5.2.1 Original Building

During operation of the Project, gas could migrate into the Original Building basement, the underground utility corridor, and ultimately through the building. Gas may migrate through the concrete mat slab foundation and concrete basement topping slab, through basement walls and elevator shafts, and/or through utility corridors and conduits. Methane will rise and accumulate at the highest elevations within a room while hydrogen sulfide will sink and accumulate at the lowest elevations within a room.

If allowed to migrate and accumulate, methane concentrations may reach the explosive limits. Presence of a spark or flame will trigger an explosion if methane is within its explosive limits. Elevated concentrations of hydrogen sulfide will result in odor issues at low concentrations and immediate death at concentrations greater than 1,000 ppm. It is also extremely flammable between 4.3 and 46 percent by volume.

Long-term groundwater dewatering will be accomplished by accumulating the impacted groundwater within the building sumps. Groundwater may be impacted as described in the Project Hydrology Report (KPF, 2014) and Project Geotechnical Report (Shannon & Wilson, 2014). As a result, long-term exposure to groundwater may result in health and safety issues for workers and the public.

Implementation of the Operational Controls Project Design Features, as specified in Chapter 4, Project Design Features, within Section 4.2.1, Operational Controls (Original Building and Underground Utility Corridor), will reduce hazards associated with the operation of the Project to less than significant.

5.2.2 New Wing

The Sphere component of the New Wing will likely have minimal gas impacts as it sits atop the underground utility corridor, which will be constructed with a methane mitigation system compliant with the LADBS code. Within the paved Piazza area, gas may become trapped beneath the pavement and preferentially migrate into the building basement.

If allowed to migrate and accumulate, methane concentrations may reach the explosive limits. Presence of a spark or flame will trigger an explosion if methane is within its explosive limits. Elevated concentrations of hydrogen sulfide will result in odor issues

at low concentrations and immediate death at concentrations greater than 1,000 ppm. It is also extremely flammable between 4.3 and 46 percent by volume.

Implementation of a methane mitigation system in accordance with the Methane Code, as specified in Chapter 4, Project Design Features, within Section 4.2.2, Operational Controls (Paved Areas) will reduce hazards associated with the operation of the Project to less than significant.

6. REFERENCES

- Association of Environmental Professionals (AEP), 2012. California Environmental Quality Act (CEQA) Statute and Guidelines.
- AMEC, 2013. Westside Subway Extension Project, Section 1 –Geotechnical Data Report – Wilshire/Fairfax Station. Prepared for Los Angeles County Metropolitan Transportation Authority. 22 May.
- Agency for Toxic Substances & Disease Regulations (ATSDR), Hydrogen Sulfide ToxFAQ, July 2006, available at: <http://www.atsdr.cdc.gov/tfacts114.pdf>
- ATSDR, 2007, Toxicological Profiles: Hydrogen Sulfide.
- Arcadis, 2012. Fourth Quarter 2012, Offsite Groundwater Monitoring Report, BRE Wilshire Property – 5220 Wilshire Boulevard. Prepared for BRE Properties, Inc. January 15.
- California Department of Conservation, Division of Oil, Gas, and Geothermal Resources, 1998. California Oil and Gas Fields, Volumes I, II and III. Vol. I (1998), Vol. II (1992), Vol. III (1982). 1,472 pp. Salt Lake information pp. 442-447.
- California Department of Conservation, Division of Oil, Gas, and Geothermal Resources, 2013. DOGGR Online Mapping System (DOMs). <http://maps.conservation.ca.gov/doms/> Accessed 1 November 2013.
- California Department of Water Resources (DWR), 2004. California's Groundwater Bulletin 118 – Los Angeles County Coastal Plain Central Basin. Updated 2/27/04.
- California Occupational Safety and Health Administration (Cal/OSHA), 2011, Pocket Guide for the Construction Industry, July, 2011.
- Cal/OSHA, 2013. Table AC-1, Permissible Exposure Limits for Chemical Contaminants, available at: https://www.dir.ca.gov/title8/5155table_ac1.html
- Carlin Environmental Consulting, Inc. (CEC), 2004. Summary of Methane Investigations for the retrofit of an existing 6-story residential building at 6006 Wilshire Boulevard, Los Angeles, California 90036, March 7, 2004.

- City of Los Angeles, 2006. L.A. CEQA Thresholds Guide: Your Resource for Preparing CEQA Analyses in Los Angeles.
- City of Los Angeles, 2013. Notification of Preparation of an Environmental Impact Report and Public Scoping Meeting, Case No. ENV-2013-1531-EIR, Academy Museum of Motion Pictures Project, 30 May 2013.
- Harden, 1998. California Geology. Prentice-Hall, Inc. 1998.
- Industrial Waste Management Division (IWMD), 2013. Industrial Waste Water Discharge Permit, available at:
http://www.lacitysan.org/iwmd/biz_industry/permit.htm
- KPFF Consulting Engineers (KPFF), 2014, Academy Museum of Motion Pictures Water Resources Technical Report, July.
- LeRoy, Crandall, and Associates (LCA), 1989. Preliminary Foundation Information, Proposed Office Building, 6122 Wilshire Boulevard, Los Angeles, California, 15 March 1989.
- Los Angeles Department of Building and Safety (LADBS), 2003, Ordinance No. 175790, Division 71 Methane Seepage Regulations, Section 91.7103, Map A-20960, dated September 21, 2003.
- Los Angeles Fire Department (LAFD), 2006. Chief's Regulation #4 Procedures: Testing of Fire Protection Equipment, Revision 02-28-06
- Los Angeles Municipal Code (LAMC) Building Code Section 91.106.4.1 Article 1 Buildings [Building Code], Division 1, Administration, 91.106.4.1 Permit Issuance.
- LAMC Building Code 91.3404.1.1, Article 1 Buildings [Building Code], Division 34 Existing Structures, 91.3404.1.1. Replacement, Retention and Extension of Original Materials.
- LAMC Building Code Article 1 Buildings [Building Code], Division 71, Methane Seepage Regulations, 91.7106. Testing, Maintenance and Service of Gas-Detection and Mechanical Ventilation Systems.

LAMC Building Code Divison 71, Methane Seepage Regulations, 91.7107 Emergency Procedures

Matheson Gas, 2001, Lower and Upper Explosive Limits for Flammable Gases and Vapors, available at: <http://www.mathesongas.com/pdfs/products/Lower-%28LEL%29-&-Upper-%28UEL%29-Explosive-Limits-.pdf>

Matheson Tri Gas, Inc., 2013. *Material Safety Data Sheet – Methane*. 12 June.

Meehan, RL; Hamilton, DA; ed. by Bernard W. Pipkin and Richard J. Proctor, 1992. Cause of the 1985 Ross Store Explosion and Other Gas Ventings, Fairfax District, Los Angeles, Engineering geology practice in southern California. Association of Engineering Geologists. Southern California Section. pp. 145–147.

Metro, 2010. Geotechnical and Hazardous Materials Technical Report, Westside Subway Extension. August.

Metro, 2012, Los Angeles County Transportation Authority, Environmental Impact Statement/Environmental Impact Report

Order No. R4-2013-0095. General NPDES Permit No. CAG994004: Waste Discharge Requirements for Discharges of Groundwater from Construction and Project Dewatering to Surface Waters in Coastal Watersheds of Los Angeles and Ventura Counties.

Order No. 2012-0006-DWQ. California General Permit for Storm Water Discharges Associated with Construction and Land Disturbance Activities.

Page Museum, 2013. Page Museum La Brea Tar Pits, Page Museum Website: www.tarpits.org . Accessed 5 November 2013.

Parsons Brinckerhoff (Parsons), 2009. Westside Extension Transit Corridor Study, Task 7.1, Deliverable (47d) Final Alternatives Analysis Report, January 2009.

Parsons, 2013. Geotechnical Baseline Report, Los Angeles County Metropolitan Authority, C1045 Westside Subway Extension Project, Section 1, 22 May 2013.

Shannon & Wilson, Inc., 2014, Geology and Soil Discipline Report, Academy of Motion Pictures, Los Angeles, California. 2014.

SCS Engineers (SCS), 1991. *Unknown Report Title, Geotechnical Investigation of 6101 Wilshire Boulevard*, 1991.

The Russell Group Architects (Russell), 1993. The Petersen Automotive Museum, 6060 Wilshire Boulevard, Los Angeles, California, Issued March 1, 1993.

Van Beveren & Butelo, Inc. (VB&B), 2005. Report of Geotechnical Investigation, Proposed Broad Contemporary Art Museum and Subterranean Garage, 5905 Wilshire Boulevard, Los Angeles, California, 27 January 2005.

VB&B, 2008. Final Report of Geotechnical Observation and Testing, Proposed Broad Contemporary Art Museum and Subterranean Garage, Tract No. PM4299, Lot Number: A, Grading Permit No.: 05030-10000-03231, 6067 Wilshire Boulevard, Los Angeles, 11 January 2008.

Wisconsin Department of Health Services (WDHS), 2010. Methane Fact Sheet, Revised December 2010. available at:
<http://www.dhs.wisconsin.gov/eh/chemfs/fs/Methane.htm>

Tables

Table 1
Minimum Methane Mitigation Requirements
City of Los Angeles Methane Zone

Site Design Level		LEVEL I		LEVEL II		LEVEL III		LEVEL IV		LEVEL V	
Design Methane Concentration (ppmv)		0-100		101-1,000		1,001-5,000		5,001-12,500		>12,500	
Design Methane Pressure (inches of water pressure)		≤2	>2	≤2	>2	≤2	>2	≤2	>2	All Pressures	
PASSIVE SYSTEM	De-watering System ¹		X	X	X	X	X	X	X	X	
	Sub-Slab Vent System	Perforated Horizontal Pipes	X	X	X	X	X	X	X	X	X
		Gravel Blanket Thickness Under Impervious Membrane	2"	2"	2"	3"	2"	3"	2"	4"	4"
		Gravel Thickness Surrounding Perforated Horizontal Pipes	2"	2"	2"	3"	2"	3"	2"	4"	4"
		Vent Risers	X	X	X	X	X	X	X	X	X
	Impervious Membrane		X	X	X	X	X	X	X	X	X
ACTIVE SYSTEM	Sub-Slab System	Pressure Sensors Below Impervious Membrane							X	X	
		Mechanical Extraction System ²							X	X	
	Lowest Occupied	Gas Detection System ³		X		X	X	X	X	X	X
		Mechanical Ventilation ^{3,4,5}		X		X	X	X	X	X	X
		Alarm System		X		X	X	X	X	X	X
	Control Panel			X		X	X	X	X	X	X
MISC. SYSTEM	Trench Dam		X	X	X	X	X	X	X	X	
	Conduit or Cable Seal Fitting		X	X	X	X	X	X	X	X	
	Additional Vent Risers ⁶									X	

X = Indicates a Required Mitigation Component

- De-watering is not required when the maximum Historical High Groundwater Table Elevation, or projected post-construction groundwater level, is more than 12 inches below the bottom of the perforated horizontal pipes
- The Mechanical Extraction System shall be capable of providing an equivalent of a complete change of air every 20 minutes of the total volume of the Gravel Blanket.
- Narrow Buildings may substitute Pressure Sensors below the Impervious Membrane in lieu of the Gas Detection System and Mechanical Ventilation, if the installation of the Pressure Sensors below the Impervious Membrane is not required per Table 2 and the Narrow Building is constructed with a minimum two feet wide landscaped area covering at least 50 percent of the ground immediately adjacent to the exterior building walls.

Table 1
Minimum Methane Mitigation Requirements
City of Los Angeles Methane Zone

4. The Mechanical Ventilation systems shall be capable of providing an equivalent of one complete change of the lowest occupied space air every 15 minutes.
5. Vent opening complying with enclosed room or space within a building exemption may be used in lieu of mechanical ventilation.
6. The total quantity of installed Vent Risers shall be increased to double the rate for the Passive System.

Table 2
Minimum Methane Mitigation Requirements
City of Los Angeles Methane Zone Buffer

Site Design Level		LEVEL I		LEVEL II		LEVEL III		LEVEL IV		LEVEL V	
Design Methane Concentration (ppmv)		0-100		101-1,000		1,001-5,000		5,001-12,500		>12,500	
Design Methane Pressure (inches of water pressure)		≤2	>2	≤2	>2	≤2	>2	≤2	>2	All Pressures	
PASSIVE SYSTEM	De-watering System ¹			X		X		X	X	X	
	Sub-Slab Vent System	Perforated Horizontal Pipes		X		X		X	X	X	X
		Gravel Blanket Thickness Under Impervious Membrane		2"		3"		3"	2"	4"	4"
		Gravel Thickness Surrounding Perforated Horizontal Pipes		2"		3"		3"	2"	4"	4"
		Vent Risers		X		X		X	X	X	X
	Impervious Membrane			X		X		X	X	X	X
ACTIVE SYSTEM	Sub-Slab System	Pressure Sensors Below Impervious Membrane							X	X	
		Mechanical Extraction System ²							X	X	
	Lowest Occupied	Gas Detection System ³			X		X		X	X	X
		Mechanical Ventilation ^{3,4,5}			X		X		X	X	X
		Alarm System			X		X		X	X	X
	Control Panel			X		X		X	X	X	X
MISC. SYSTEM	Trench Dam			X		X		X	X	X	
	Conduit or Cable Seal Fitting			X		X		X	X	X	
	Additional Vent Risers ⁶										X

X = Indicates a Required Mitigation Component

- De-watering is not required when the maximum Historical High Groundwater Table Elevation, or projected post-construction groundwater level, is more than 12 inches below the bottom of the perforated horizontal pipes
- The Mechanical Extraction System shall be capable of providing an equivalent of a complete change of air every 20 minutes of the total volume of the Gravel Blanket.
- Narrow Buildings may substitute Pressure Sensors below the Impervious Membrane in lieu of the Gas Detection System and Mechanical Ventilation, if the installation of the Pressure Sensors below the Impervious Membrane is not required per Table 2 and the Narrow Building is constructed with a minimum two feet wide landscaped area covering at least 50 percent of the ground immediately adjacent to the exterior building walls.

Table 2
Minimum Methane Mitigation Requirements
City of Los Angeles Methane Zone Buffer

4. The Mechanical Ventilation systems shall be capable of providing an equivalent of one complete change of the lowest occupied space air every 15 minutes.
5. Vent opening complying with enclosed room or space within a building exemption may be used in lieu of mechanical ventilation.
6. The total quantity of installed Vent Risers shall be increased to double the rate for the Passive System.

Figures

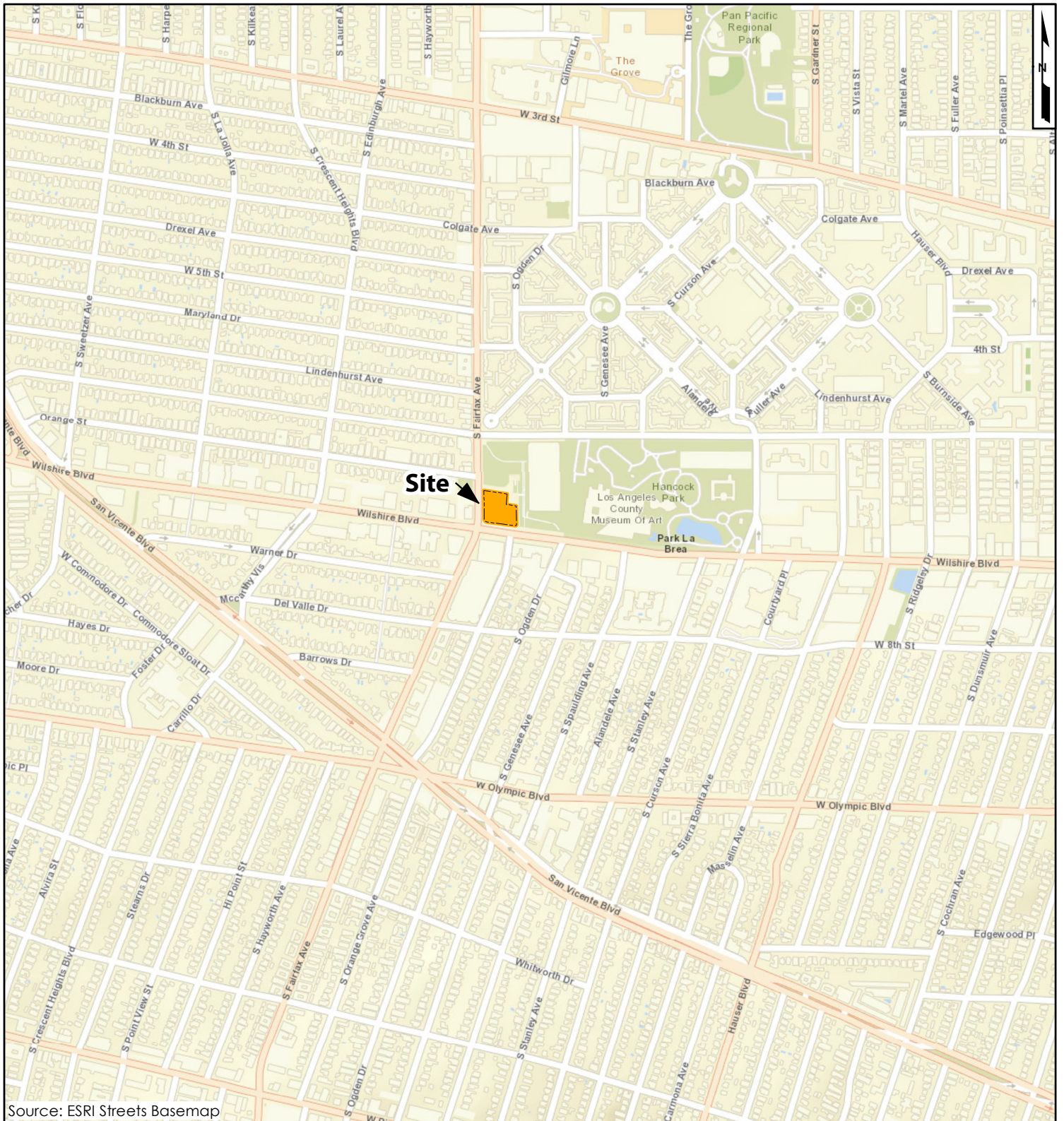

Source: ESRI Streets Basemap

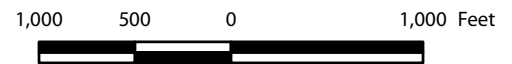

Site Location Map

6067 Wilshire Blvd
Los Angeles, California

Geosyntec
consultants

Figure

1

San Diego

July 2014

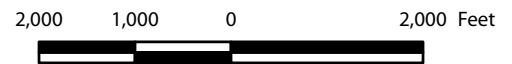
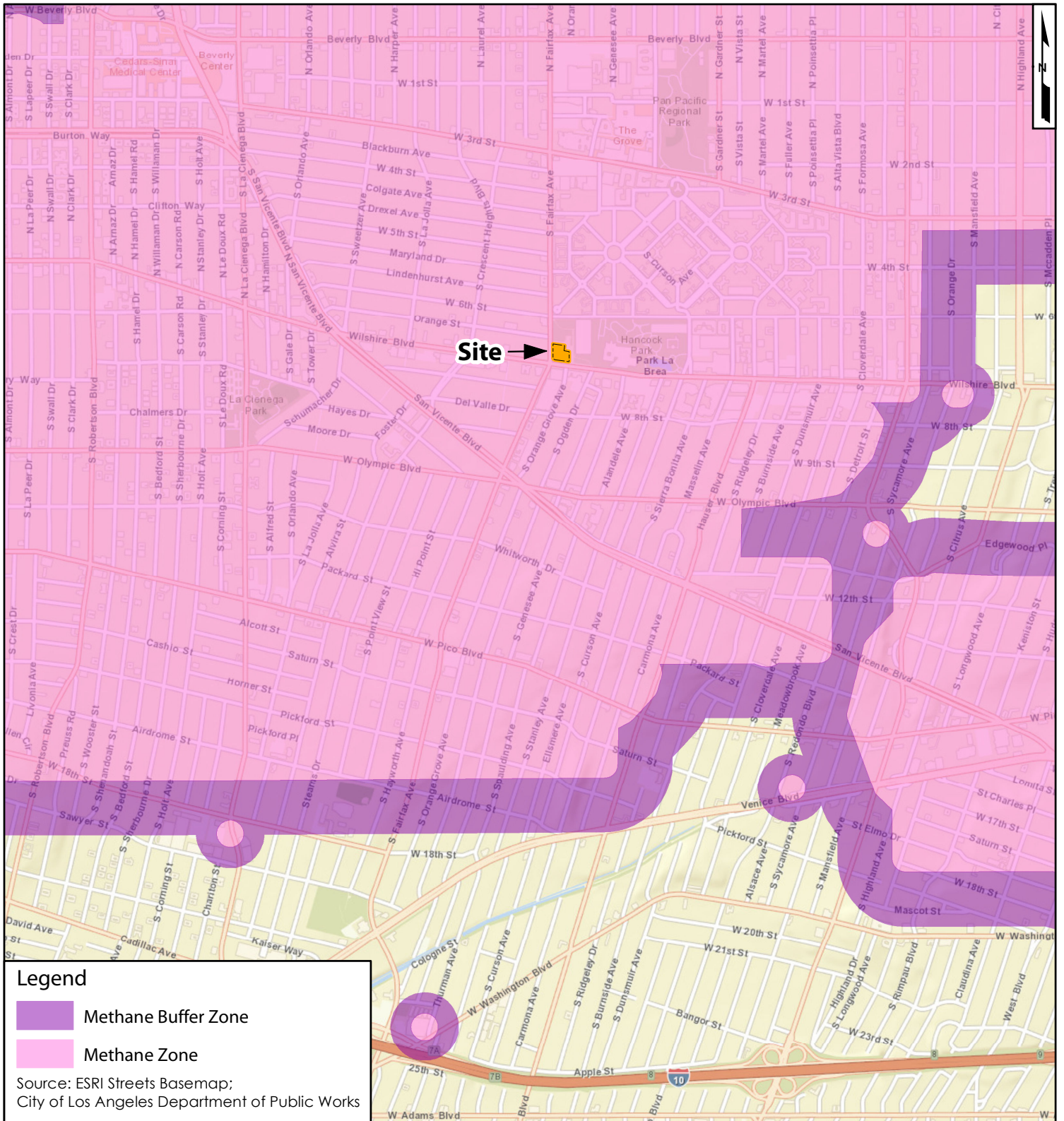

High Methane Zone

6067 Wilshire Blvd
Los Angeles, California

Geosyntec
consultants

Figure

2

San Diego

July 2014



P:\PRJ\SCAD\DCADD\SC0683\F01\F02.DWG - DRAWN BY:MCARLSON

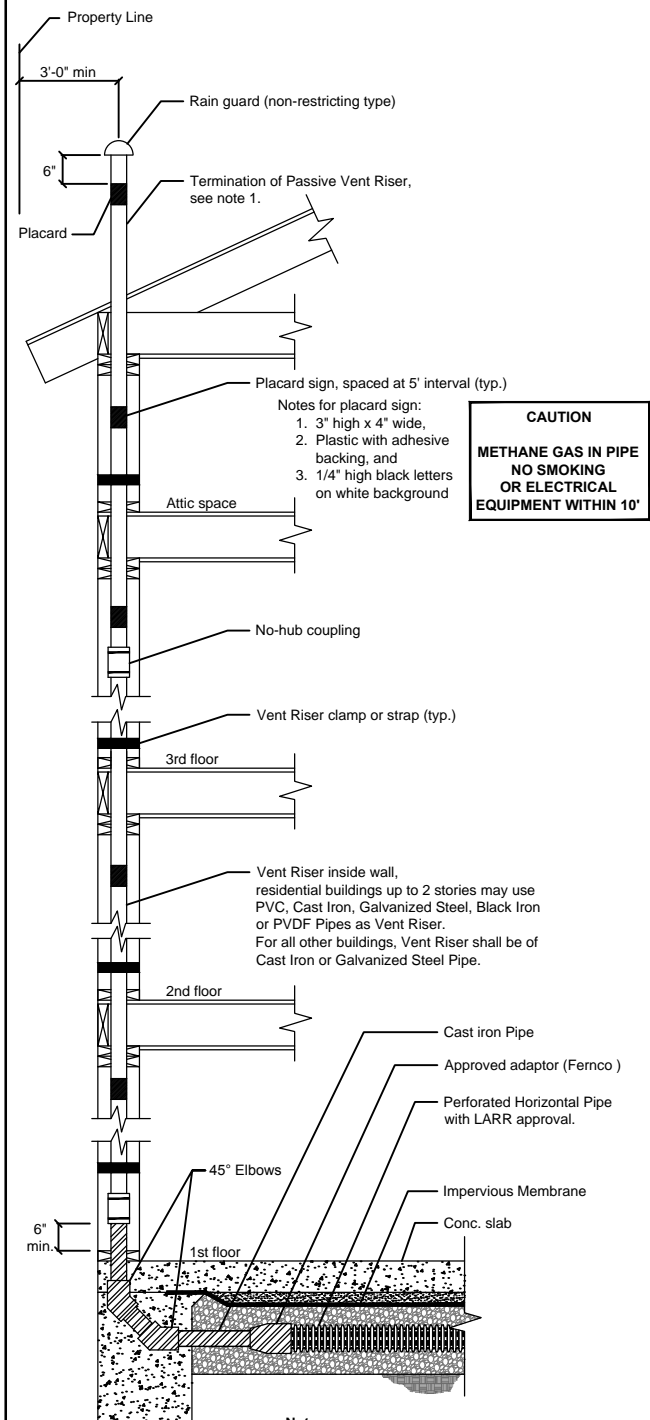

- Notes:**
1. Termination of Passive Vent Riser shall be as follows (LAMC 94.906.0):
 - a. 10' min. away from, or at least 3' above any openable window, door, opening or air intake, or vent shaft.
 - b. 3' min. in every direction from any lot line, alley, and street.
 - c. Extend through the vent flashing, 6" min. above the roof, and 1' min. from any parapet or building wall.
 2. Wrap all piping with approved material through concrete slab or floor.
 3. Support all piping per Table 3-2 of Los Angeles Plumbing Code.
 4. The piping of the venting system shall be tested with air in accordance with Section 94.712.3 of the Los Angeles Plumbing Code.

CAUTION
METHANE GAS IN PIPE
NO SMOKING
OR ELECTRICAL
EQUIPMENT WITHIN 10'

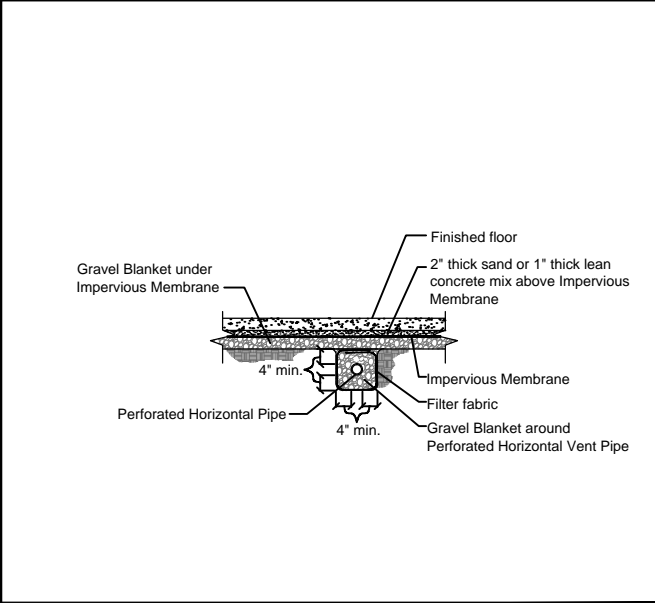

Sub-Slab Vent System **Detail 1**
 Scale: Not to Scale

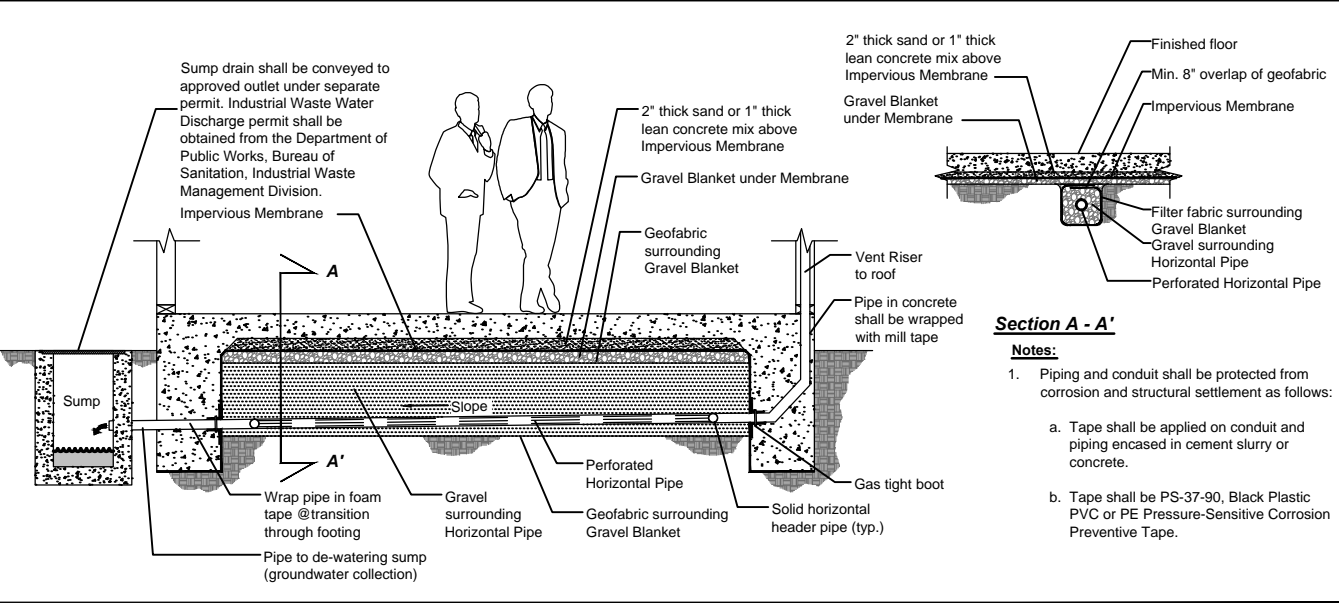

Combination De-Watering and Vent Pipe **Detail 2**
 Scale: Not to Scale

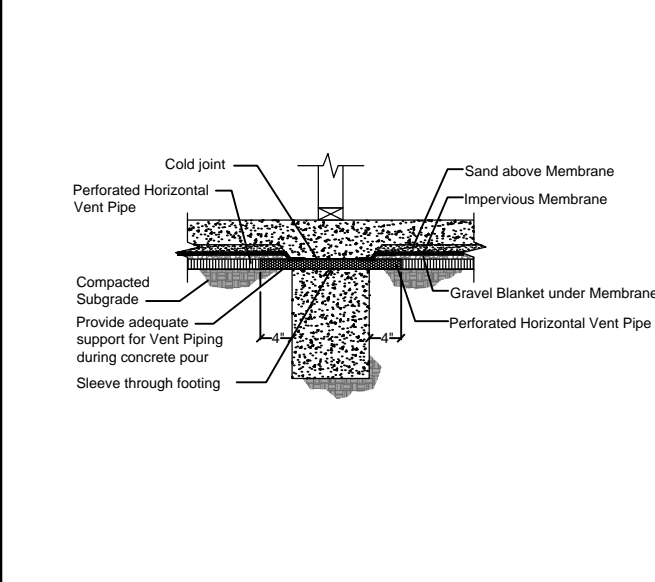

Vent Pipe at Interior Footing **Detail 3**
 Scale: Not to Scale

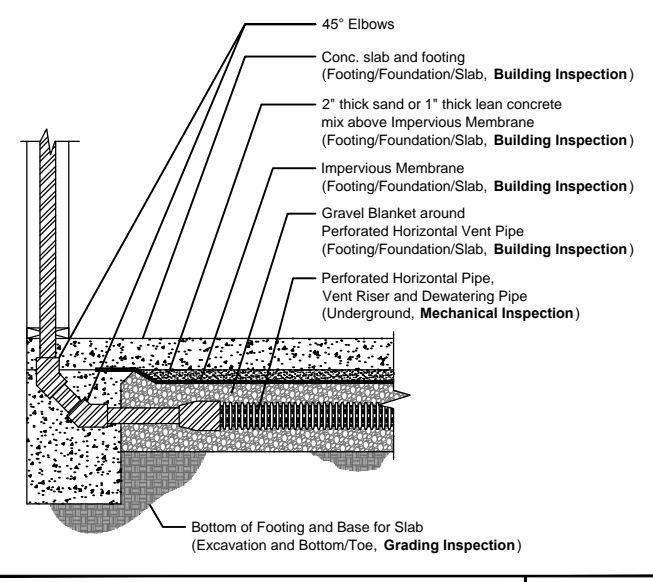

Inspection (Request inspection using the terminologies shown in this detail) **Detail 5**
 Scale: Not to Scale

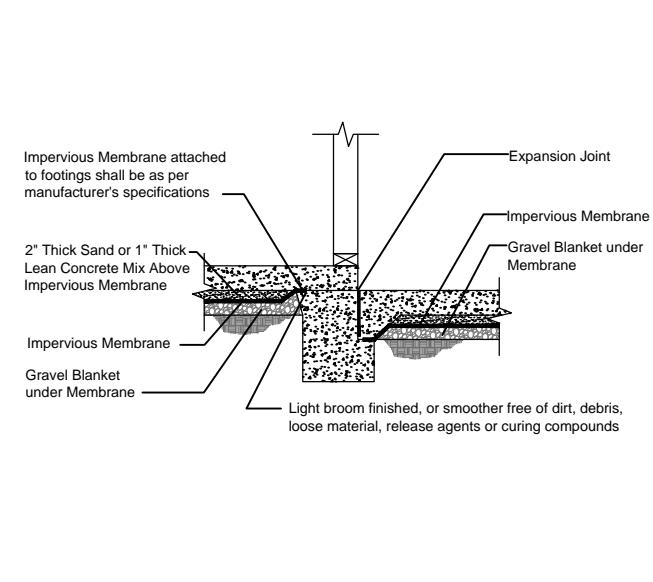

Membrane Termination at Interior Footing **Detail 6**
 Scale: Not to Scale

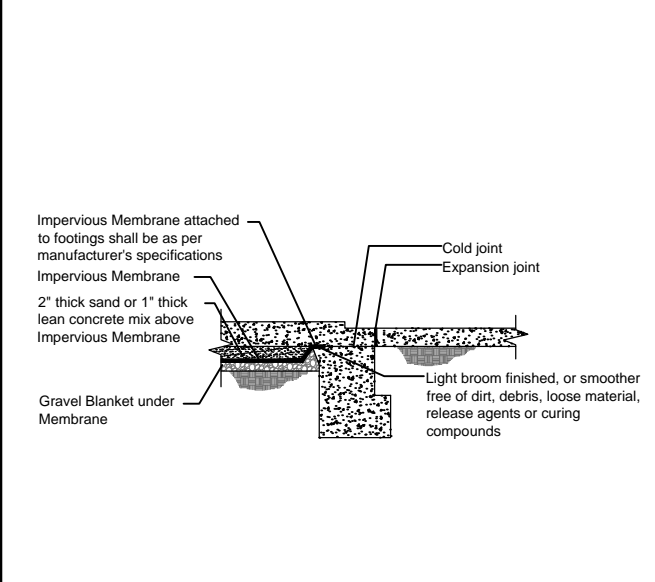

Membrane Termination at Exterior Grade Beam **Detail 7**
 Scale: Not to Scale

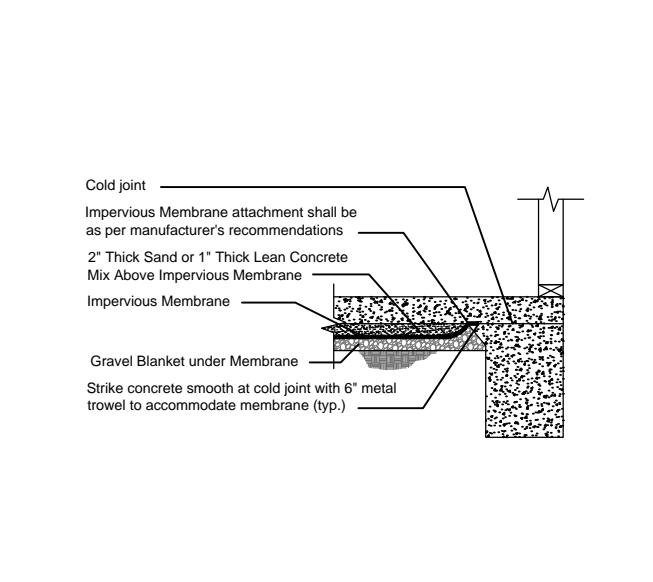

Membrane Termination at Exterior Footing - Two Pour **Detail 8**
 Scale: Not to Scale

Vent Riser **Detail 4**
 Scale: Not to Scale

METHANE MITIGATION SYSTEM DETAILS (1 OF 11)
 PROPOSED ACADEMY MUSEUM OF MOTION PICTURES
 6067 WILSHIRE BOULEVARD
 LOS ANGELES, CALIFORNIA

Geosyntec consultants

DATE: JULY 2014
 PROJECT NO. SC0683

FIGURE
3

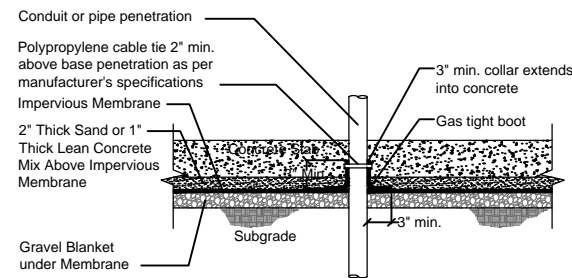

Membrane Boot

Detail 9
Scale: Not to Scale

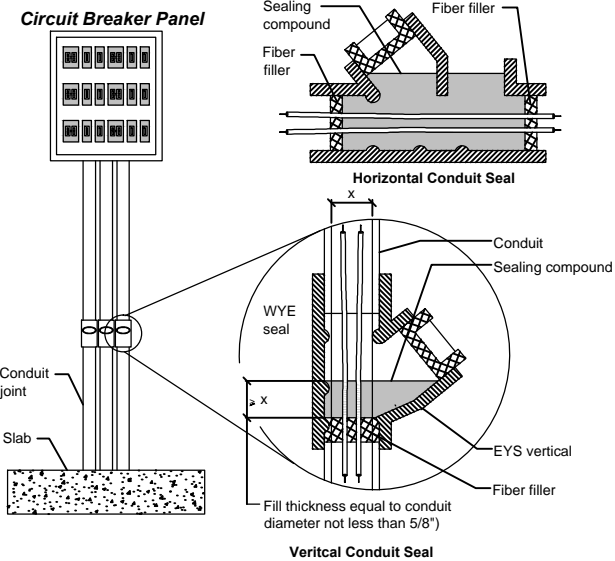

Conduit Seal

Detail 10
Scale: Not to Scale

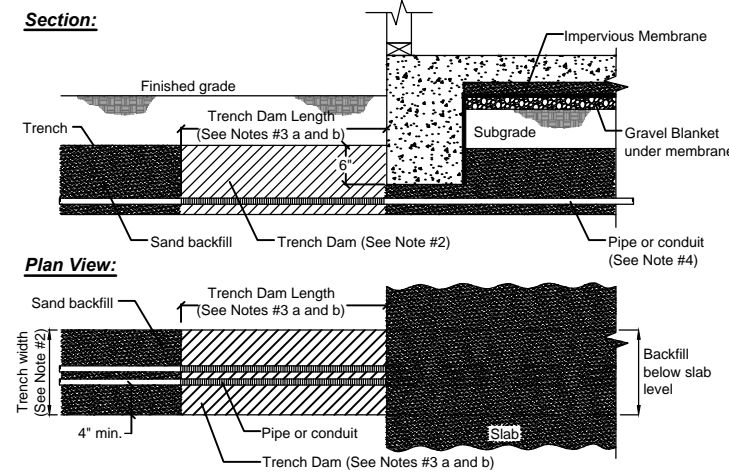

Trench Dam

Detail 11
Scale: Not to Scale

Notes: Trench Dams

1. All Trench Dams shall be installed in trenches containing piping and conduit that connects directly from the utility lines in the street.
2. The width of a Trench Dam shall be one half the length.
3. Trench Dams shall be constructed of one of the following:
 - a. Bentonite Cement Slurry three feet long: A mixture of 4% Type II Cement, and 2% Powdered Bentonite.
 - b. Compacted Native Soils Backfill five feet long: Native soils shall be compacted to at least 90% relative compaction in accordance with ASTM D-1557 Testing Procedures.
 - c. Concrete mixes other than Bentonite Cement Slurry may be used provided conduit or piping is wrapped with High Density PVC Foam Tape, Closed Cells, Adhesive Backed, 1/4" thick by 1/2" wide shall be applied to clear surface with ends butted together at most visible locations in Trench Dam.
4. Piping and conduit shall be protected from corrosion and structural settlement as follows:
 - a. Tape shall be applied on conduit and piping encased in cement slurry or concrete.
 - b. Tape shall be PS-37-90, Black Plastic PVC or PE Pressure-Sensitive Corrosion Preventive Tape.

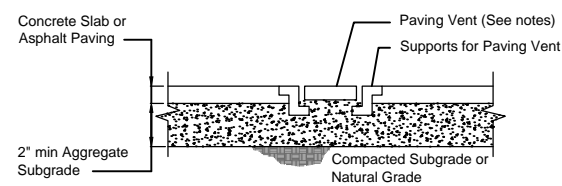

Notes:

1. Paving Vent shall be constructed on cast iron.
2. Paving Vent shall be installed at the same rate as the vent risers.
3. Paving Vent shall be spaced a maximum of 100' apart.
4. Net area of openings in each Paving Vent shall be 12 square inches.

Paved Areas Venting

Detail 12
Scale: Not to Scale

P:\PRJ\SCADD\CADD\SC0683 AMM\PI\FIGURES\SC0683-F01-F02.DWG - DRAWN BY:MCARLSON

METHANE MITIGATION SYSTEM DETAILS (11 OF 11)
 PROPOSED ACADEMY MUSEUM OF MOTION PICTURES
 6067 WILSHIRE BOULEVARD
 LOS ANGELES, CALIFORNIA



DATE: JULY 2014
 PROJECT NO. SC0683

FIGURE

4

