

J. HUEBNER,
 AMUSEMENT DEVICE.
 APPLICATION FILED JULY 2, 1908.

914,723.

Patented Mar. 9, 1909.
 3 SHEETS—SHEET 1.

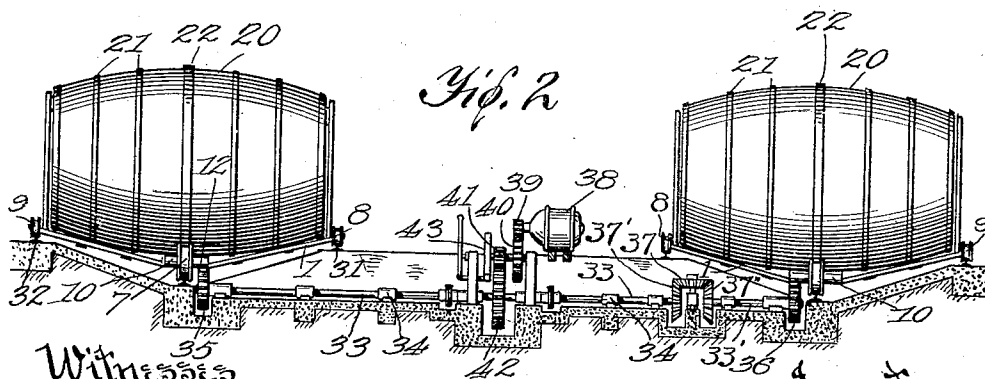
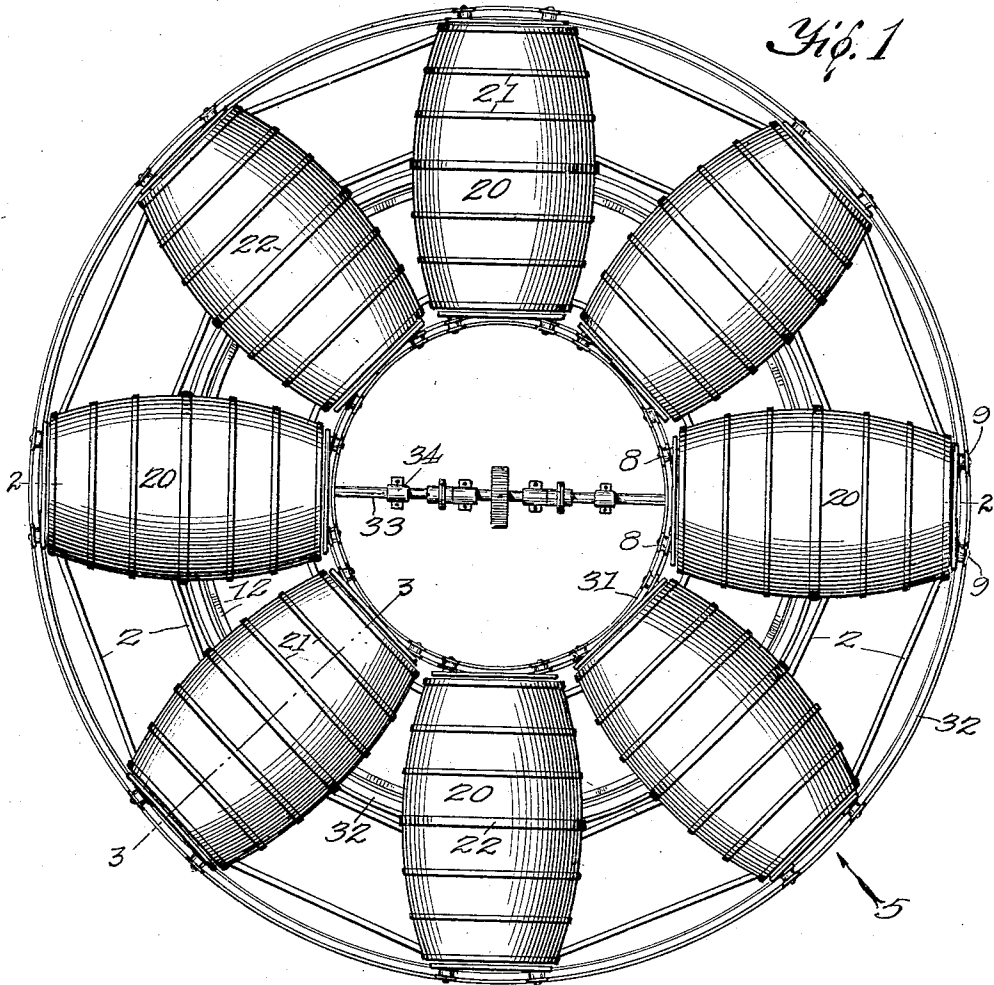

Witnesses
 E. N. Lichtenberg
 G. J. Rudmer

Inventor
 John Huebner
 by Carl M. Crawford
 Atty.

J. HUEBNER.
 AMUSEMENT DEVICE.
 APPLICATION FILED JULY 2, 1908.

914,723.

Patented Mar. 9, 1909.

3 SHEETS—SHEET 2.

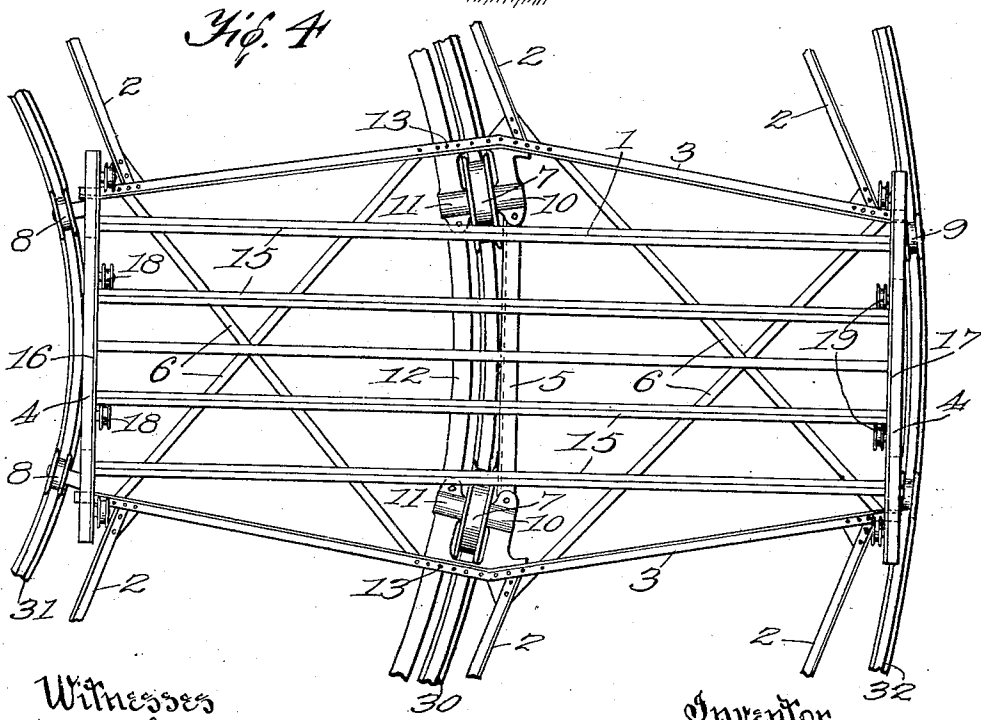
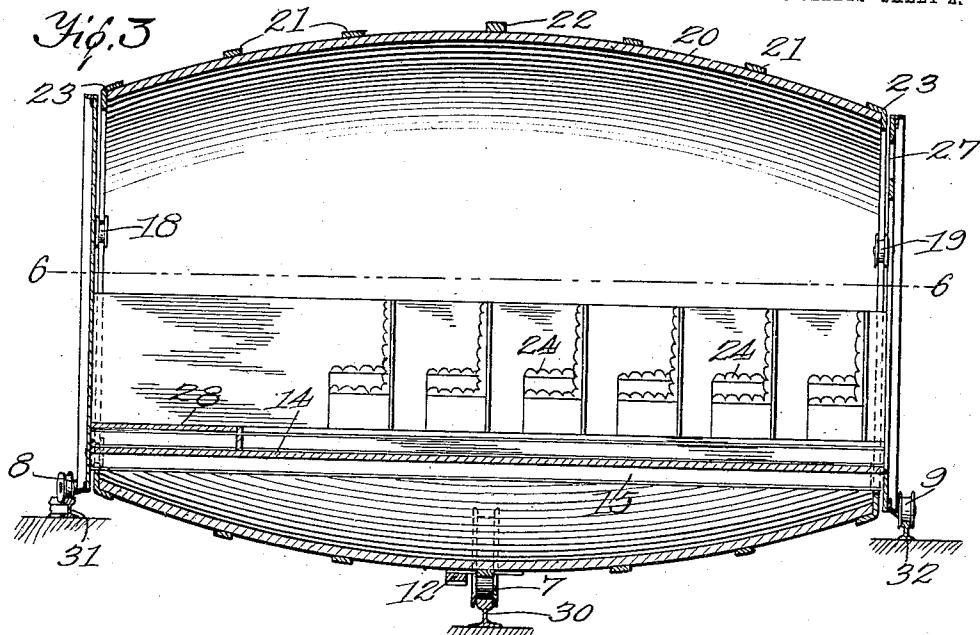

Witnesses
E. H. Lichtenberg
G. Lindmen

Inventor
John Huebner
 by *Carl M. Crawford*
 Att'y.

J. HUEBNER.
 AMUSEMENT DEVICE.
 APPLICATION FILED JULY 2, 1908.

914,723.

Patented Mar. 9, 1909.
 3 SHEETS—SHEET 3.

Fig. 5

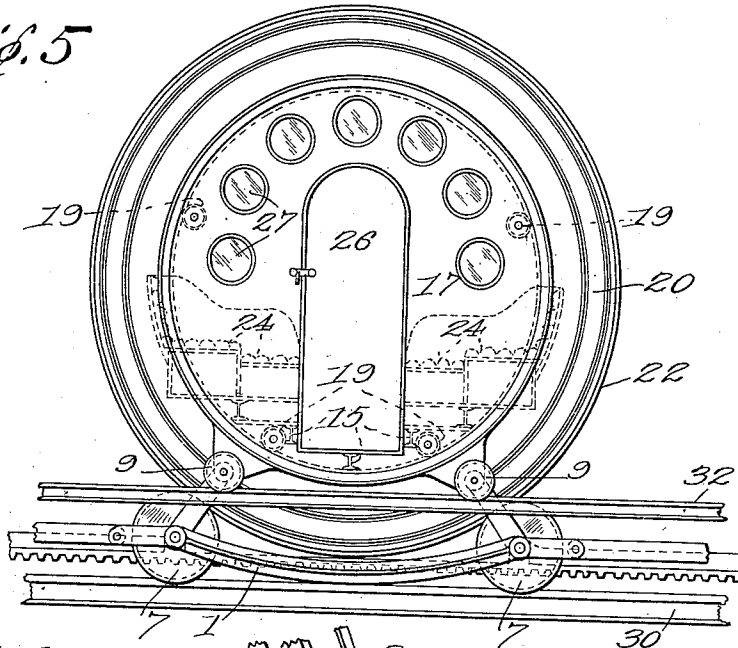
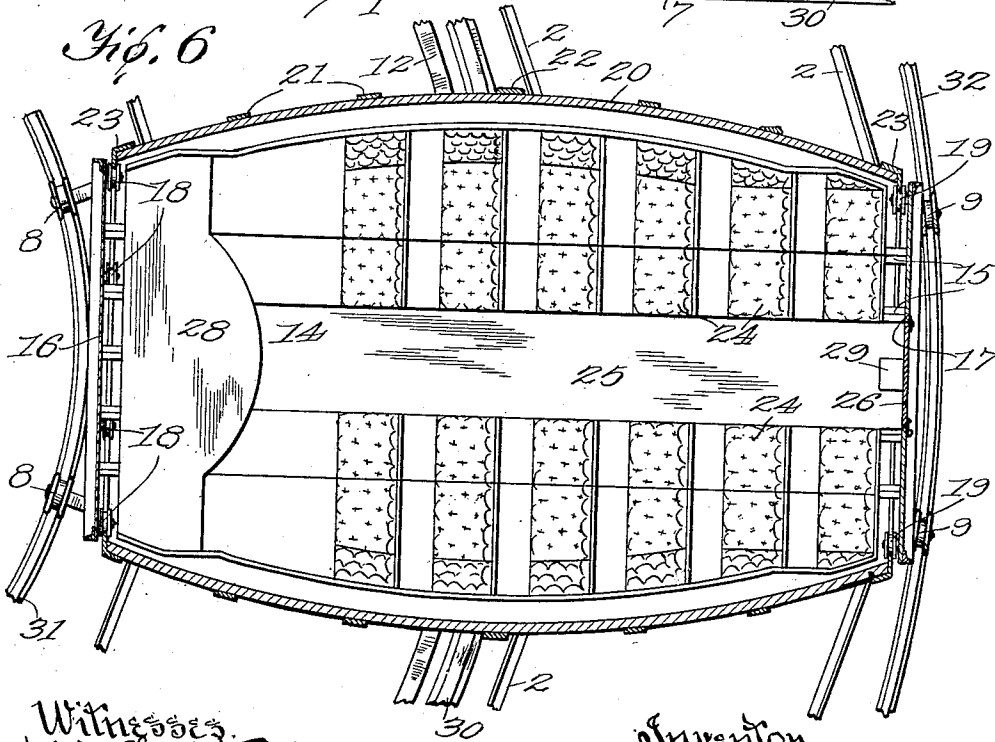

Fig. 6



Witnesses.
E. H. Lichtenberg
G. Lindmen

Inventor
John Huebner
 by *Carl M. Crawford*
 Atty.

UNITED STATES PATENT OFFICE.

JOHN HUEBNER, OF CHICAGO, ILLINOIS, ASSIGNOR TO THE BARREL AMUSEMENT CO., A CORPORATION OF ILLINOIS.

AMUSEMENT DEVICE.

No. 914,723.

Specification of Letters Patent.

Patented March 9, 1909.

Application filed July 2, 1908. Serial No. 441,706.

To all whom it may concern:

Be it known that I, JOHN HUEBNER, a citizen of the United States, residing at Chicago, in the county of Cook and State of Illinois, have invented certain new and useful Improvements in Amusement Devices, of which the following is a specification.

This invention relates to improvements in amusement devices of that character wherein the passengers are housed in inclosures which are bodily movable and to which movement is imparted independently of such bodily movement.

The device of my invention is preferably embodied in a circular structure of the merry-go-round type, and comprises a supporting structure on which is provided a plurality of rigid platforms for receiving the passengers and about which platforms there are disposed movable inclosures adapted to be revolved as the result of the propelling movement imparted to the structure.

My invention will be more fully described in connection with the accompanying drawings and will be more particularly pointed out and ascertained in and by the appended claims.

In the drawings—Figure 1 is a plan view of a device embodying the main features of my invention; Fig. 2 is a cross-sectional view thereof on line 2—2 of Fig. 1, with the inclosures in elevation; Fig. 3 is a sectional view on line 3—3 of Fig. 1; Fig. 4 is a plan view of a portion of the supporting structure, with the inclosure removed; Fig. 5 is an end view looking in the direction of the arrow 5 of Fig. 1; and Fig. 6 is a sectional view on line 6—6 of Fig. 3.

Like numerals of reference designate similar parts throughout the different figures of the drawings.

In the specific embodiment shown, the device of my invention is embodied in a circular structure adapted to be rotated or propelled about a fixed axis, but it will be understood that my invention is not to be limited to the specific form disclosed in the drawings, except such limitations as the claims import.

Referring to the drawings, the device of my invention comprises a plurality of radially disposed trucks designated as a whole at 1 and united by connecting members 2 to form a unitary circular supporting structure. Each truck may consist of a skeleton frame

comprising lateral members 3 connected at their ends by transverse members 4 and united midway of their ends by a transverse member 5. If desired, the truck frame may be stiffened by cross braces 6, as clearly shown in Fig. 4. If the supporting structure is designed to run upon rails, it may be supported by operating wheels, as indicated at 7, and by auxiliary supporting wheels 8 and 9, which wheels, in the embodiment shown, are disposed beneath the trucks.

I desirably provide each truck with two centrally disposed operating wheels 7 and two supporting wheels 8 and 9 at the inner and outer ends of each truck. Conveniently, bearings 10 for the wheels 7 are mounted on the transverse members 5 and bearings 11 are mounted on a circular member 12 which extends completely around and beneath the trucks and which may be secured at 13 to the lateral members 3 thereof. Preferably, the circular member 12 is in the form of a rack, by means of which the structure is propelled, as will hereinafter more fully appear. Each truck is conveniently provided with a platform which is designated as a whole at 14, each platform extending longitudinally of, and somewhat above the truck on which it is supported. As shown, each platform is supported by a plurality of I-beams 15, the ends of which are secured to inclosure walls 16 and 17 which latter are rigidly mounted on the trucks. Said walls are provided with wheels 18 and 19, the purpose of which will hereinafter more fully appear.

An inclosure is provided for each truck, and, as shown, said inclosures are in the form of barrels 20 which are open at both ends. Each barrel is provided with the usual hoops 21 and near their central portions each barrel is provided with a bearing ring 22 adapted to seat or rest in the grooved peripheries of the wheels 7. As shown in Fig. 4, said wheels 7 are laterally disposed with respect to the longitudinal central axis of each truck so that they will engage the bearing rings of the barrels at points laterally of the center of gravity thereof. Substantially the entire weight of each barrel is imposed upon the wheels 7, and it will be readily seen that when the structure is propelled the barrels will be rotated by said wheels. The barrels are of sufficient diameter to completely surround

the platform 14, and said barrels extend substantially throughout the length thereof, the ends of said barrels being closed by the walls 16 and 17 which are conveniently formed circular for this purpose. In order to prevent the barrels from overbalancing or tipping on the wheels 7, each barrel is rotatively connected with the truck structure, and this feature is conveniently realized by providing the opposite ends of the barrels with rims 23 which project inwardly in a manner to engage the rollers 18 and 19, as clearly shown in Fig. 6. In view of the fact that the rollers 18 and 19 are provided merely for the purpose of maintaining the rotating barrels in a prescribed position, the said rollers are disposed near the central and lower portions of the walls 16 and 17.

The device of my invention is not only designed to carry the occupants throughout a prescribed course of travel, but it is also designed to provide amusement and otherwise enhance the enjoyment of the occupants and to this end each platform is provided with a plurality of seats or benches 24 which may conveniently be disposed on opposite sides of an aisle 25 to which entrance may be provided by means of doors 26. The end walls 16 and 17 may, if desired, be provided with ventilating openings 27 or reliance may be placed upon the spaces between the end walls and the barrels to provide ventilation. A stage 28 may conveniently be disposed at one end of each platform, and the inner surface of the end walls 16 may be utilized as a canvas support upon which pictures may be projected, and the lantern or other projecting device 29 may conveniently be disposed on the outer wall 17. In order to provide further amusement for the occupants, the interior walls of the barrels may be decorated in any desirable manner, thereby creating the illusion to the occupants of traveling bodily and axially while the device is in motion.

As shown, the wheels 7 travel upon a centrally disposed track 30 while the wheels 8 and 9 travel upon inner and outer rails 31 and 32.

As shown, the structure is propelled by means which is of the following construction:—Shafts 33 and 33' are mounted in bearings 34 and are provided at their ends with pinions 35 and 36 respectively. Pinions 35 and 36 mesh with the rack 12. Shaft 33 is driven in one direction and an idler 37 is interposed between pinions 37' and 37'', mounted on shafts 33 and 33', respectively, to obtain a driving action at the right of Fig. 2 in a reverse direction to the driving action of the left of said figure. An electric motor 38, or other source of power, may be connected with the shaft 33 by a reducing gear 39, 40, 41 and 42, as shown. A band brake 43 is indicated gen-

erally and need not be shown or described in detail, as it forms no part of the present invention.

It will also be understood that I do not wish to be limited to the particular form of driving means herein shown, as the latter may be varied without departing from the spirit of the invention.

I claim—

1. An amusement device comprising in combination, a plurality of radially disposed trucks connected with each other to form a circular structure, centrally disposed barrel operating truck wheels for each truck, rollers supporting the inner and outer ends of said trucks, a barrel for each truck resting on said centrally disposed wheels, a platform for each truck projecting longitudinally through each barrel and out of engagement therewith, inner and outer walls rigidly mounted on each truck for closing the ends of said barrels, each of said walls being provided with rollers engaging the ends of said barrels, a circular rack carried by said trucks, and means engaging said rack to propel said structure and rotate said barrels.

2. An amusement device comprising in combination, a plurality of radially disposed trucks connected with each other to form a circular structure, centrally disposed barrel operating truck wheels for each truck, rollers supporting the inner and outer ends of said trucks, a barrel for each truck resting on said centrally disposed wheels, a platform for each truck projecting longitudinally through the barrel thereof, inner and outer end walls for each truck closing the ends of the barrel and supporting the platform thereof, each of said walls being provided with rollers engaging the ends of said barrels, a circular rack carried by said trucks, and means engaging said rack to propel said structure and rotate said barrels and circular tracks for said truck wheels.

3. An amusement device comprising in combination, a plurality of radially disposed trucks connected with each other to form a circular structure, centrally disposed barrel operating truck wheels for each truck, wheels for the ends of said trucks, circular tracks for said wheels, a barrel for each truck resting on the centrally disposed wheels thereof, a platform for each truck projecting through the barrel thereof, means carried by said trucks and movably connected with and closing the ends of said barrels, and means propelling said structure and operating said barrels.

4. An amusement device comprising in combination, a plurality of radially disposed trucks connected with each other to form a circular structure, barrel operating truck wheels for each truck, supporting wheels for each truck, circular tracks for said wheels, platforms for each truck, a barrel for each

truck surrounding the platform thereof and rotatably mounted on said operating wheels and trucks, and means for propelling said structure.

5 5. An amusement device comprising in combination, a plurality of trucks connected with each other to form a unitary structure, each truck being provided with a rigid platform, supporting and barrel operating
10 wheels, and a barrel for each truck resting on said operating wheels and rotatively connected with said trucks.

6. An amusement device comprising in combination, a plurality of trucks connected
15 with each other to form a unitary structure, each truck being provided with a rigid platform and operating supporting wheels, inclosures surrounding said platforms and
20 pelling said structure.

7. An amusement device comprising in combination, a supporting structure provided with a plurality of rigid platforms, operating supporting wheels for said structure, inclosures surrounding said platforms
25 and operated by said wheels, and means for propelling said structure.

8. An amusement device comprising in combination, a supporting structure provided with a plurality of rigid platforms,
30 inclosures for said platforms, means for propelling said structure, and means for rotating said inclosures when said structure is propelled.

In testimony whereof I affix my signature
35 in presence of two witnesses.

JOHN HUEBNER.

Witnesses:

HANS KRAUT,

CARL H. CRAWFORD.