

(12) **UK Patent Application** (19) **GB** (11) **2 371 964** (13) **A**

(43) Date of A Publication **07.08.2002**

(21) Application No **0102479.3**

(22) Date of Filing **31.01.2001**

(71) Applicant(s)  
**TCT International plc**  
**(Incorporated in the United Kingdom)**  
**6 The Long Room, Coppermill Lock,**  
**Summerhouse Lane, HAREFIELD, Middx, UB9 6JA,**  
**United Kingdom**

(72) Inventor(s)  
**Norman Ronald Smith**  
**Ivan Daniel Meir**

(74) Agent and/or Address for Service  
**Venner Shipley & Co**  
**20 Little Britain, LONDON, EC1A 7DH,**  
**United Kingdom**

(51) INT CL<sup>7</sup>  
**A61B 6/04 6/08 , A61N 5/10**

(52) UK CL (Edition T )  
**H5R REK**

(56) Documents Cited  
**JP 100024118 A**                    **US 5823192 A**  
**US 4208675 A**

(58) Field of Search  
**UK CL (Edition S ) H5R REK**  
**INT CL<sup>7</sup> A61B 6/04 6/08 , A61N 5/10**  
**Online: WPI, EPODOC, JAPIO**

(54) Abstract Title  
**Surface imaging for patient positioning in radiotherapy**

(57) A 3D surface image capturing system is used to obtain data defining the external anatomy of a patient for application in radiotherapy treatment and planning. The system is first calibrated to the isocentre of the planning or treatment room. The system is used to assist in patient identification, patient positioning and during both treatment planning and the treatment itself, to ensure that the treatment is as localised as possible to the tumour under treatment, taking account of patient movements including respiration, both during a course of treatment and between courses of treatment. Since the system is a surface imaging system, the use of conventional marker systems for tracking patient movement can be avoided.

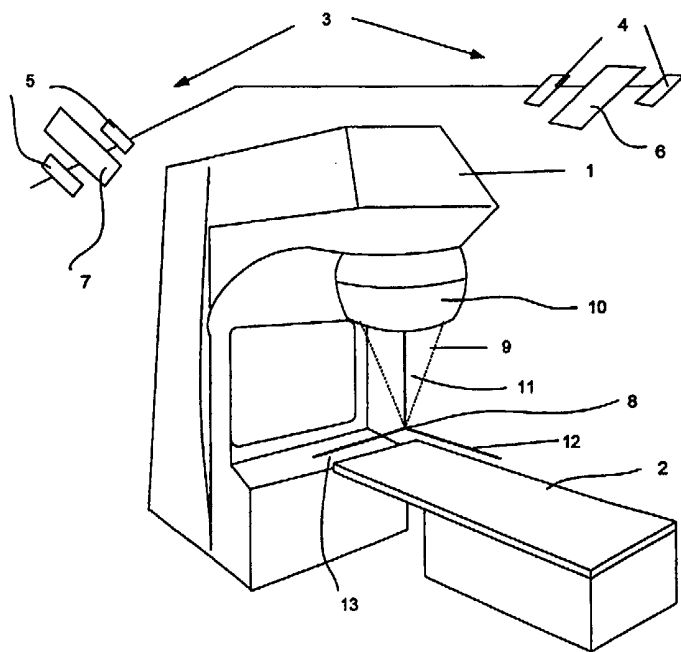

Figure 1

**GB 2 371 964 A**

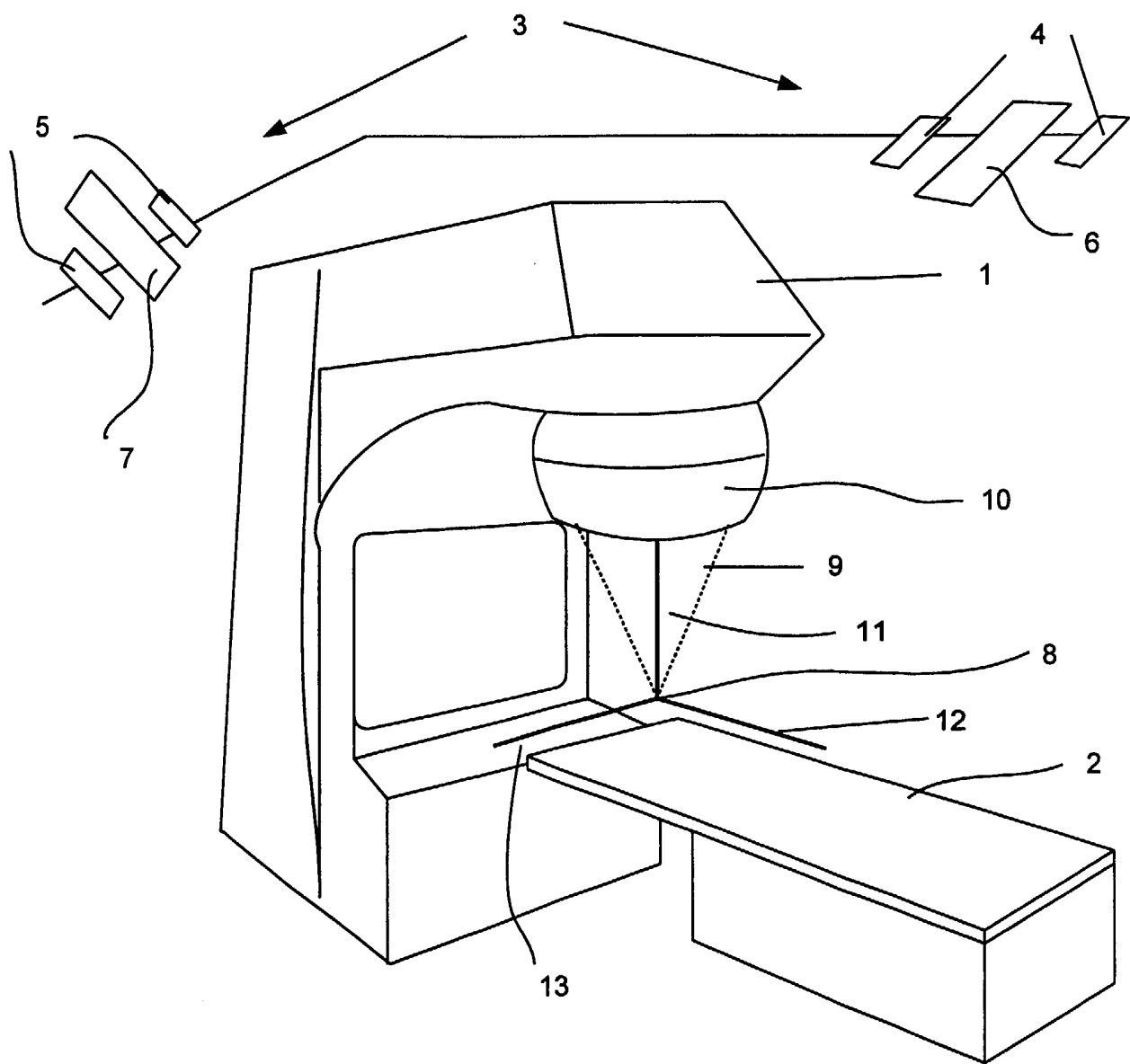

Figure 1

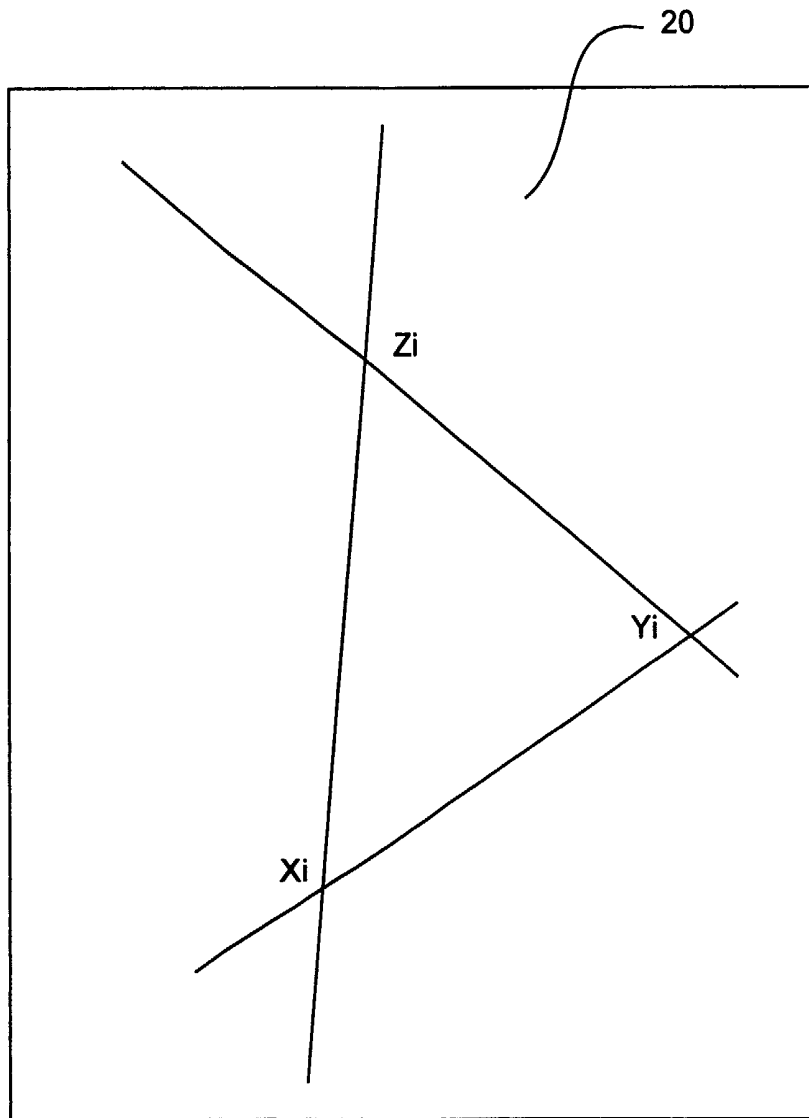

Figure 2

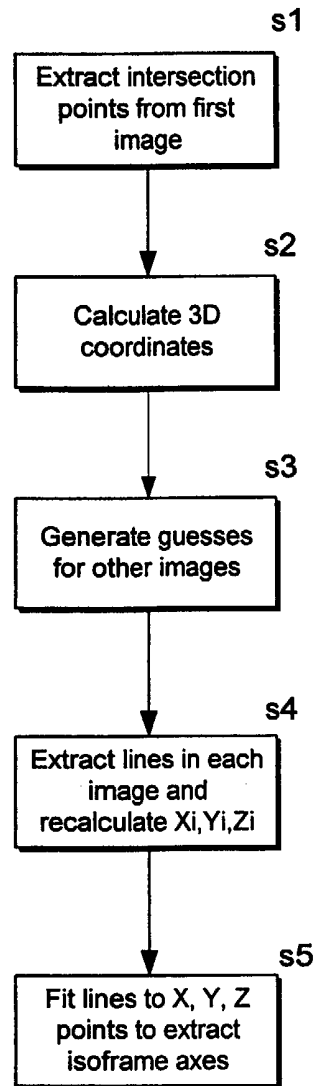

Figure 3

## Surface Imaging

### Description

The present invention relates to the application of 3D surface imaging techniques to assist in medical treatment, particularly but not exclusively in radiotherapy.

3D surface imaging, in particular digital surface photogrammetry (DSP), is a technique for acquiring information about the surface characteristics of an object, enabling the surface to be modelled in three dimensions.

10

Conventional radiotherapy treatment involves two main stages, the first being treatment planning within a simulator and the second being the application of radiation from a linear accelerator in a treatment room, either as a one-off application or fractionated over time. Since radiotherapy involves the application of radiation which is damaging to healthy as well as diseased cells, it is important to ensure that treatment is limited as far as possible to the diseased part of the body, such as a tumour, while avoiding healthy tissue.

15

A variety of techniques are used in conjunction with radiotherapy to track body motion to ensure correct application of radiation. The majority of these require the use of some sort of active or passive marker attached to the body part being treated or markers in the form of tattoos. However, there are a number of limitations with such approaches. First, it is not always convenient or even possible to attach markers to the relevant parts of the body. Second, radiotherapy usually requires repeatable positioning of a subject over time, for example in fractionated treatment, a course of which can last, for example, six weeks. In such cases it is impractical to keep the markers fixed to the subject and it is difficult and time consuming to re-affix them once removed. Furthermore, changes to the body over time or even during treatment, such as tensing and relaxation of muscles, can cause significant errors in patient positioning.

20

25

30

According to the present invention there is provided a method of patient positioning in radiotherapy comprising using a surface based imaging system to

obtain an image of a surface of the patient's body in a treatment planning procedure and using said image to position the patient during a treatment procedure.

Embodiments of the invention will now be described by way of example with  
5 reference to the accompanying drawings in which:

Figure 1 is a diagrammatic perspective view of an example of a system according to the invention;

Figure 2 is a schematic diagram showing the laser planes used in the isocentre  
10 calibration procedure; and

Figure 3 is a flow diagram of the calibration procedure.

As mentioned above, radiotherapy workflow involves treatment planning within a simulator and the application of radiation from a linear accelerator (linac). Surface  
15 image capture technology can be integrated within either, or both, of these two environments. In either case it is envisaged that a number of surface image capture cameras are affixed to either the simulator or the linac so that they are calibrated to the isocentre of either environment, as will be explained in detail below.

Alternatively, the cameras be attached to an independent apparatus whose position  
20 in space is known in relation to the isocentre, or some other fixed point in the planning/treatment room. An example of a radiotherapy treatment system is shown in Figure 1.

Referring to Figure 1, a system according to the invention comprises a linear  
25 accelerator (linac) 1 for providing radiotherapy treatment for a patient on a treatment couch 2, and a 3D surface imaging system 3 comprising a central pair of cameras 4, a side pair of cameras 5 and white light speckle projectors 6, 7 between each pair of cameras. Instead of white light speckle projectors, infra-red or flash projectors can be used. The principles behind the 3D surface imaging system  
30 described are described in International publication numbers WO96/06325, WO99/06950 and WO99/60525, the disclosure of each of which is incorporated herein by reference. Alternative 3D surface imaging systems 3 can also be used, for example the S4M 3D surface capture system from 3dMD LLC or techniques based

on laser scanning and moiré fringes. Reference is further directed to International publication number WO96/12160, the disclosure of which is incorporated herein by reference. While the above example has been described in relation to a camera system having two pairs of cameras, it is envisaged that multiple stereo pairs of cameras, for example, three pairs are used for maximum coverage. A multiple non-paired camera arrangement can also be used, for example multiple cameras evenly spaced along the arc of an ellipsoid.

The cameras are first calibrated using standard techniques, such as those used to calibrate the 3dMD LLC DSP 400 system. A stereo matching algorithm is applied so that corresponding points are determined between pairs of images and through the process of triangulation, a 3D surface model is reconstructed. Reference is further directed to Otto GP, Chau TKW, "Region Growing Algorithm for the Matching of Terrain Images", Image and Vision Computing, 1989, Vol. 7, No. 2, pp. 83-93 for a detailed discussion of the stereo matching algorithm.

To enable the surfaces captured by the calibrated cameras to be used for positioning/contouring, their position relative to a known reference frame that is also used by the radiotherapists needs to be determined. This reference frame is well known in radiotherapy and is referred to herein as the isoframe. The point origin of the isoframe is the treatment isocentre 8, which is the focal point of the uncollimated radiation beam 9, situated directly below the head 10 of the linac 1. One coordinate axis 11 runs through the centre of this beam and the plane of rotation of the linac head 1 defines a coordinate plane passing through the isocentre which serves to complete the isoframe. The linac is built to rotate about the isocentre 8 during treatment to high precision.

The central pair of cameras 4 is located a known distance, for example 1.4m from the isocentre 8, while the side pair of cameras 5 is located, for example, 2.2m from the isocentre 8.

Currently the isoframe is used to reposition patients. The three orthogonal coordinate axes 11, 12, 13 are made visible by lasers mounted on the walls of the

treatment room which project planes of laser light, which coincide with the iso-frame coordinate planes. In standard terminology, these are the x-y, y-z and z-x planes. On intersection with the patient's skin they form a net of intersecting lines that can be used for positioning by identifying and marking the crossing points.

5

The lasers are used to perform a basic isocentre calibration as described in more detail below. The described calibration method is independent of surface reconstruction and registration. As an alternative, a more direct method can be used. This relies on the fact that the lasers themselves are calibrated using a pointer attached to the linac head 10 to detect the isocentre 8 and a box arrangement which is described below to calibrate their orthogonality. By combining the pointer with a photogrammetric calibration object, a more precise iso-calibration can be performed.

10

15 The basic calibration method uses a flat white plate 20, to detect the laser planes. The plate is positioned at an angle, so that it cuts off a corner of the box-shape formed by the lasers to form a triangular shape. The plate is moved towards the isocentre 8 and behind it, maintaining the same orientation, and an image is taken at each position, with at least two cameras. As shown in Figure 2, if the three axes 10, 20 11, 12 of the iso-frame are referred to as X, Y and Z, then the corresponding intersection in image i is denoted by  $X_i$ ,  $Y_i$  and  $Z_i$ . To simplify and standardise the images captured, a board is placed on the treatment couch 2, with a number of oblique, angled grooves into which the flat plate is inserted. The algorithm now proceeds as follows.

25

The three line intersection points from the first image are manually extracted (step s1) and triangulation used to calculate their 3D coordinates (step s2). Assuming that the planes are orthogonal, this then completely defines the iso-frame in space as the intersection of three spheres with diameters  $X_1Y_1$ ,  $Y_1Z_1$  and  $Z_1X_1$ .

30

Using the frame just calculated, and knowing the relationship between the plate positions from either the grooved positioning board mentioned above or from surface reconstruction, initial guesses for X, Y and Z in the other images are



generated (step s3). The guesses are used as initialisation for a line detection algorithm which accurately extracts the laser lines in each image and re-calculates  $X_i$ ,  $Y_i$  and  $Z_i$  (step s4). Lines are fitted to the X, Y and Z points to extract the iso-frame axes (step s5).

5

As an alternative to the angled and grooved board, the board has a single groove for receiving the flat plate in a known position on the treatment couch 2 and the couch 2 is then rotated and moved to provide the required positioning of the flat plate.

10 The ability of the couch movement system to provide accurate coordinates for initialisation provides for a repeatable initialisation procedure and leads to a semi-automatic or automatic way to perform initialisation.

Recent experiments have found that the isoframe was extracted with interior angles less than 0.1 degrees off perpendicular. Also, the 3D point distances from the lines  
15 were all sub-millimetre.

An example of a surface image capture arrangement in conjunction with a linear accelerator has been described above. It will be apparent to the skilled person that any arrangement can be used which provides an equivalent result, i.e. enables  
20 surface image data to be captured and calibrated to a radiotherapy environment.

Once calibrated, the system can be applied in accordance with the invention to a wide range of applications during radiotherapy planning and treatment.

25 Integration of 3D textured digital surface photogrammetry (DSP) data with either 3D CT, 2D X-ray info, or data from any other modality (e.g. MR, PET, SPECT, and so on) can assist the clinician/technician when determining the location of a patient's tumour and computing the associated plan. Furthermore, DSP data with accompanying photo-realistic texture is captured during a treatment plan and stored  
30 within the associated patient record, to double check that the correct patient is admitted during treatment, or that the correct part of the patient's anatomy is being treated. This can be particularly useful for medico-legal purposes.

Patient positioning is one of the most difficult problems in radiotherapy, in particular when treating breast, thoracic, pelvic and other such non-rigid regions of anatomy. Accurate repositioning of the patient is required during treatment to replicate the radiotherapy plan. Repositioning is achieved by, for example,  
5 comparing surface images during simulation and treatment. In addition, coded target stickers can be applied to permanent tattoos, marking various anatomical locations on the patient, during simulation and treatment. The coded targets are then tracked in real-time using the DSP system described above. The treatment couch is then automatically adjusted so that the distance error for any given marker  
10 between the treatment plan and the actual treatment is minimised.

In order to compensate for any non-rigid changes in external anatomy, comparisons are made between the simulation and treatment skin surfaces, using measures such as projected distance, relative surface orientation, and the like. These are computed  
15 and visually displayed in near real-time and hence aid the radiographer to move the patient until the external anatomy and position optimally replicates that achieved during planning. Real-time updates of the tracked surface enhance the visual feedback for the radiographer. In addition, these updates facilitate real-time stereo matching to be performed on the acquired stereo image data, to enable very fast  
20 surface acquisition/update, which can be further improved via seed-pointing on tracked markers. The position of the internal anatomy can be confirmed using the portal image, to aid the radiotherapist in deciding how well the internal anatomy lines up with the simulated position. A combination of near real-time surface capture with real time point tracking can also be used as an input to the linac gantry  
25 to detect potential collisions with the patient. This set-up can also be used to warn the operator if the patient moves during treatment or can be configured to automatically switch off the beam if movement exceeds a pre-set threshold. Even if no radiation is cut off, the ability to quantify the expected degree of motion during a future treatment, based on retrospective analysis, allows the treatment plan to be  
30 modified in order to take this into account in future treatment sessions. A further variation on this is to use the surface image information to gate the linear accelerator so that it only applies radiation during a fixed point in the respiratory

cycle. This minimises delivery errors that are caused by patient motion during respiration.

5 In order to determine how to compensate the radiotherapy beam, for example, via a tungsten wedge, so that the applied beam is more uniform, which helps to avoid hot spots, the external surface contour of the region being treated is required. DSP data is therefore acquired during treatment to provide an accurate, high-resolution contour for this purpose. Furthermore, when planning IMRT (Intensity Modulated RadioTherapy), the same information is required. For example, when irradiating the  
10 breast, tangential to the chest wall, the thickness of tissue receiving radiation changes across it, the regions close to the edge contour having almost zero thickness. This can be compensated with knowledge of the 3D breast surface.

15 Sometimes, radiotherapy is administered in the form of an electron beam. There is a close relationship between the external surface of the patient and the internal penetration of the beam. Again, DSP data provides the associated surface information.

20 The registration of DSP data with CT/MR and other modalities is beneficial as a method to aid communication between radiotherapists, as well as between radiotherapist and surgeon, by placing the volumetric image data within the visual surface context.

25 Furthermore, in order to obtain a CT scan which can be registered with the treatment room co-ordinate system, it is necessary to repeat scan a patient following simulation, with various CT sensitive markers attached to the patient whose position can be repeated in the treatment room. The CT imaged markers, or equivalent, are then be used to register the CT co-ordinate system to the treatment room co-ordinate system. In accordance with the invention, a 3D DSP surface is  
30 acquired within the simulator and the diagnostic CT data is registered to the DSP surface, which has already been calibrated to the isocentre of the radiotherapy environment. This avoids the need to repeat capture a therapeutic CT scan. In addition, it provides a method for performing frameless stereotactic radiotherapy.

The acquisition of a high resolution DSP surface also enables rapid prototyping of solid models from which immobilisation devices, such as plastic masks, can be produced. In addition, other surface contact devices can be produced in the same way. It will be appreciated that the technique according to the invention can eliminate the need for masks which serve the dual purpose of immobilisation and repositioning, by using the surface imaging technique to achieve repositioning and other methods for immobilisation, for example immobilisation using vacuum based techniques.

## Claims

1. A method of patient positioning in radiotherapy comprising:  
using a surface based imaging system to obtain an image of a surface of the  
5 patient's body in a treatment planning procedure; and  
using said image to position the patient during a treatment procedure.
2. A method according to claim 1, wherein the treatment is delivered by a  
radiation beam, further comprising gating the beam in dependence on the image.  
10
3. A method according to claim 1 or 2, wherein the image is a three  
dimensional image.
4. A method according to any one of the preceding claims, including tracking  
15 the surface image in real-time.
5. A method according to any one of the preceding claims, wherein the surface  
based imaging system comprises a multiple camera system for providing stereo  
imaging.



INVESTOR IN PEOPLE

Application No: GB 0102479.3  
Claims searched: 1-5

10

Examiner: Eamonn Quirk  
Date of search: 9 October 2001

### Patents Act 1977 Search Report under Section 17

#### Databases searched:

UK Patent Office collections, including GB, EP, WO & US patent specifications, in:

UK Cl (Ed.S): H5R (REK)

Int Cl (Ed.7): A61B (6/04, 6/08) A61N (5/10)

Other: Online: WPI, EPODOC, JAPIO

#### Documents considered to be relevant:

Category	Identity of document and relevant passage	Relevant to claims
X	US 5 823 192 (University of Pittsburgh) whole document	1 at least
X	US 4 208 675 (Anvar) whole document	1 at least
X	JP100024118 A (Shimadzu Corp.) See WPI abstract	1 at least

X	Document indicating lack of novelty or inventive step	A	Document indicating technological background and/or state of the art
Y	Document indicating lack of inventive step if combined with one or more other documents of same category.	P	Document published on or after the declared priority date but before the filing date of this invention.
&	Member of the same patent family	E	Patent document published on or after, but with priority date earlier than, the filing date of this application.