



US005979558A

United States Patent [19]

[11] Patent Number: **5,979,558**

Bouldin et al.

[45] Date of Patent: ***Nov. 9, 1999**

[54] **VARIABLE CHOKE FOR USE IN A SUBTERRANEAN WELL**

[76] Inventors: **Brett Wayne Bouldin**, 707 Creek Forest Cir., Spring, Tex. 77380; **Napoleon Arizmendi**, 11910W. Presley, Magnolia, Tex. 77355

[*] Notice: This patent issued on a continued prosecution application filed under 37 CFR 1.53(d), and is subject to the twenty year patent term provisions of 35 U.S.C. 154(a)(2).

[21] Appl. No.: **08/898,567**

[22] Filed: **Jul. 21, 1997**

[51] Int. Cl.⁶ **E21B 34/06**

[52] U.S. Cl. **166/363; 166/373; 166/334.4**

[58] Field of Search **166/363, 373, 166/364, 332.1, 334.1, 334.4**

[56] **References Cited**

U.S. PATENT DOCUMENTS

- 1,747,910 2/1930 Siefarth .
- 2,178,540 11/1939 McNeese et al. .
- 3,821,962 7/1974 Mott .
- 4,062,406 12/1977 Akkerman et al. .
- 4,162,691 7/1979 Perkins .
- 4,252,143 2/1981 Fredd .
- 4,569,370 2/1986 Witt 137/625.3

- 4,633,952 1/1987 Ringgenberg .
- 4,848,472 7/1989 Hopper 166/339 X
- 4,896,722 1/1990 Upchurch 166/53 X
- 5,176,220 1/1993 Akkerman .
- 5,211,241 5/1993 Mashaw, Jr. et al. .
- 5,316,084 5/1994 Murray et al. 166/332
- 5,431,188 7/1995 Cove 137/625.3

FOREIGN PATENT DOCUMENTS

2159194 11/1985 United Kingdom .

OTHER PUBLICATIONS

Search Report for Application PCT/GB98/02242. Master Flow Valve, Inc. catalog, undated.

Primary Examiner—Roger Schoeppel
Attorney, Agent, or Firm—Marlin R. Smith

[57] **ABSTRACT**

A flow control apparatus and associated methods of using provide enhanced longevity and reliability without requiring complex mechanisms. In a described embodiment, a choke for use within a subterranean well has a choke member set which may be opened by manipulation of an inner tubular cage. The inner cage is displaced from within an outer sleeve, which restricts fluid flow through ports formed through a sidewall portion of the inner cage. As the inner cage is progressively withdrawn from within the sleeve, the fluid flow through the ports is decreasingly restricted by the sleeve.

58 Claims, 5 Drawing Sheets

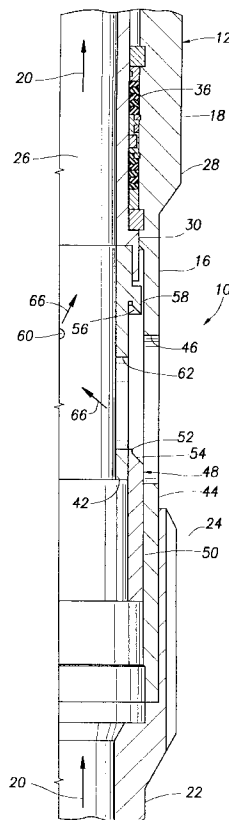
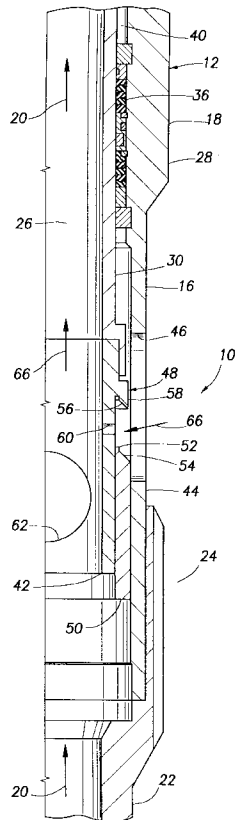

FIG. 1A

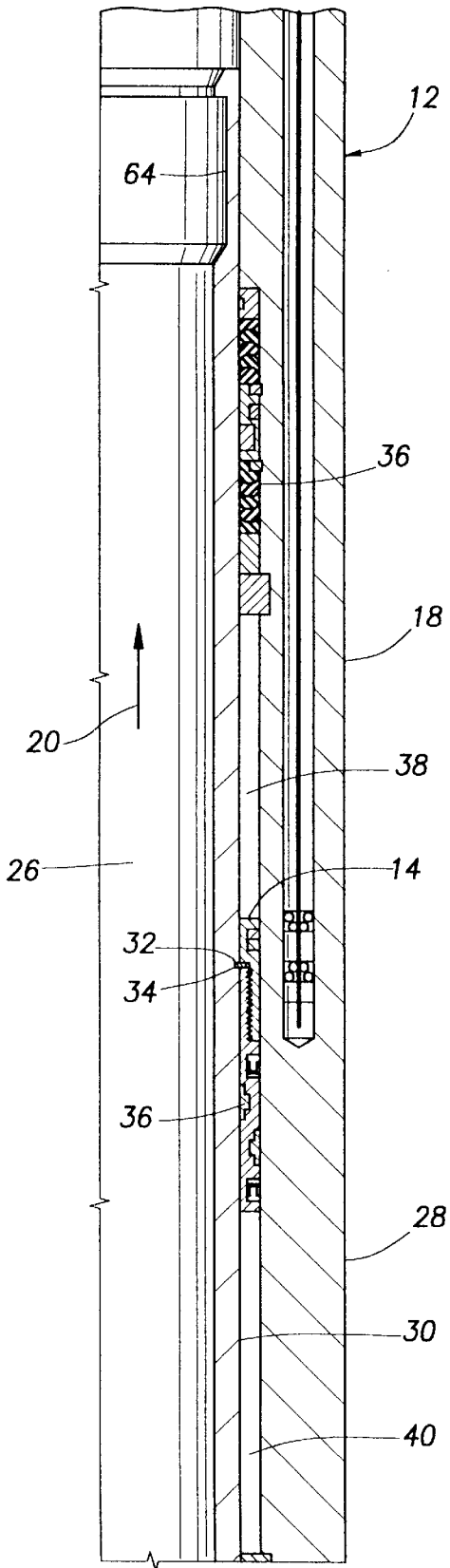

FIG. 1B

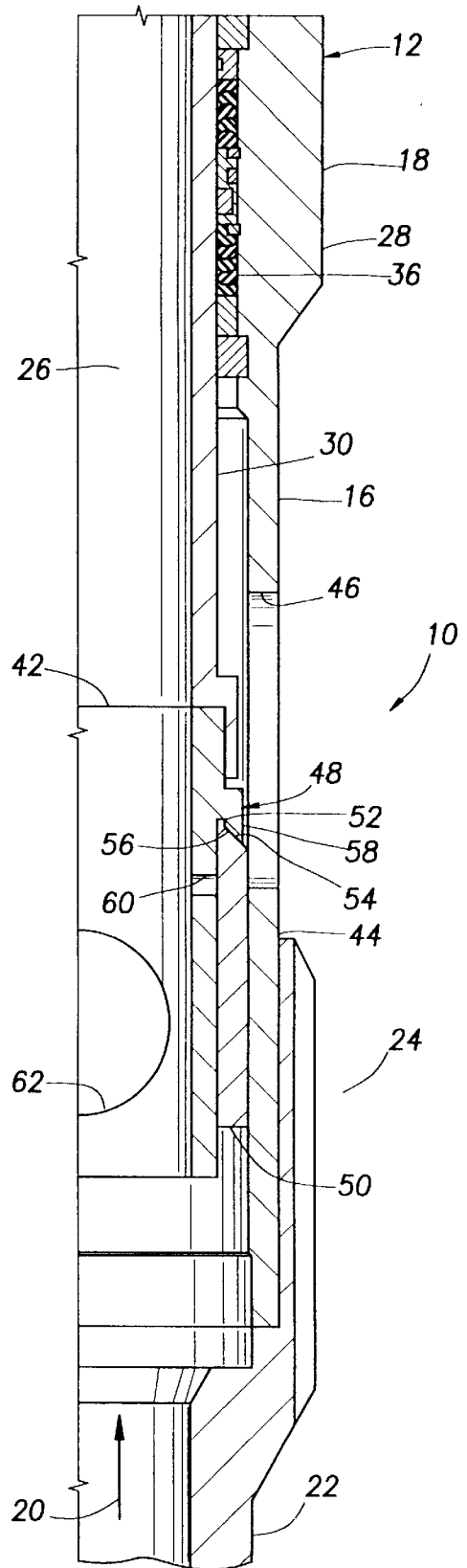

FIG. 4

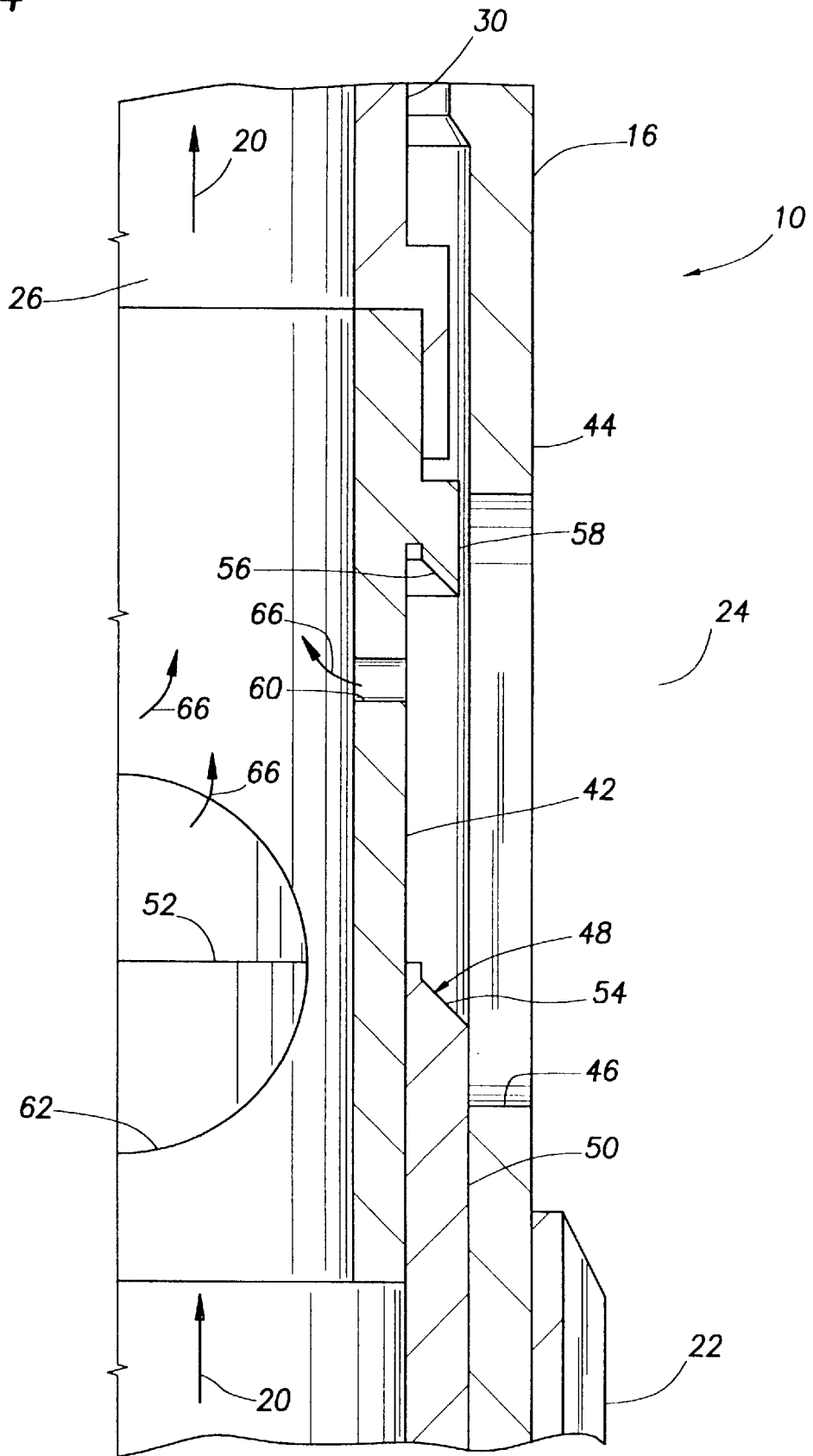

FIG. 5A

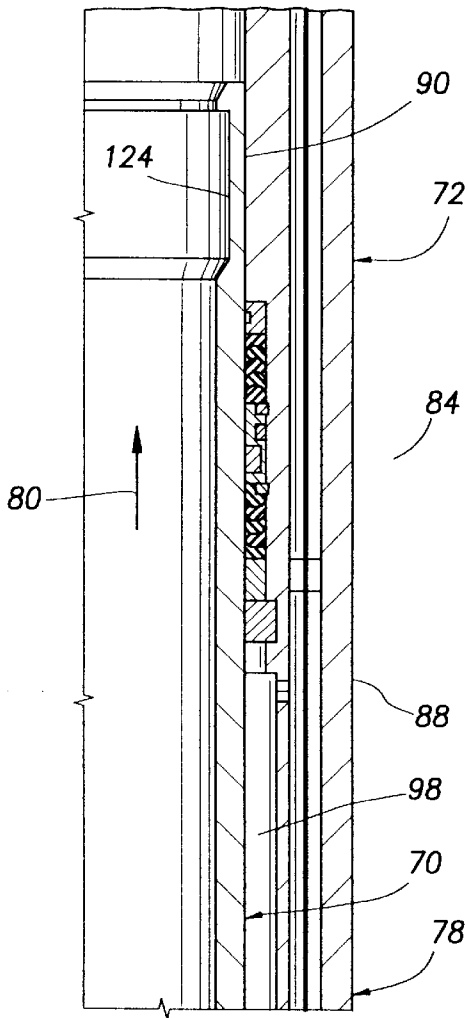

FIG. 5B

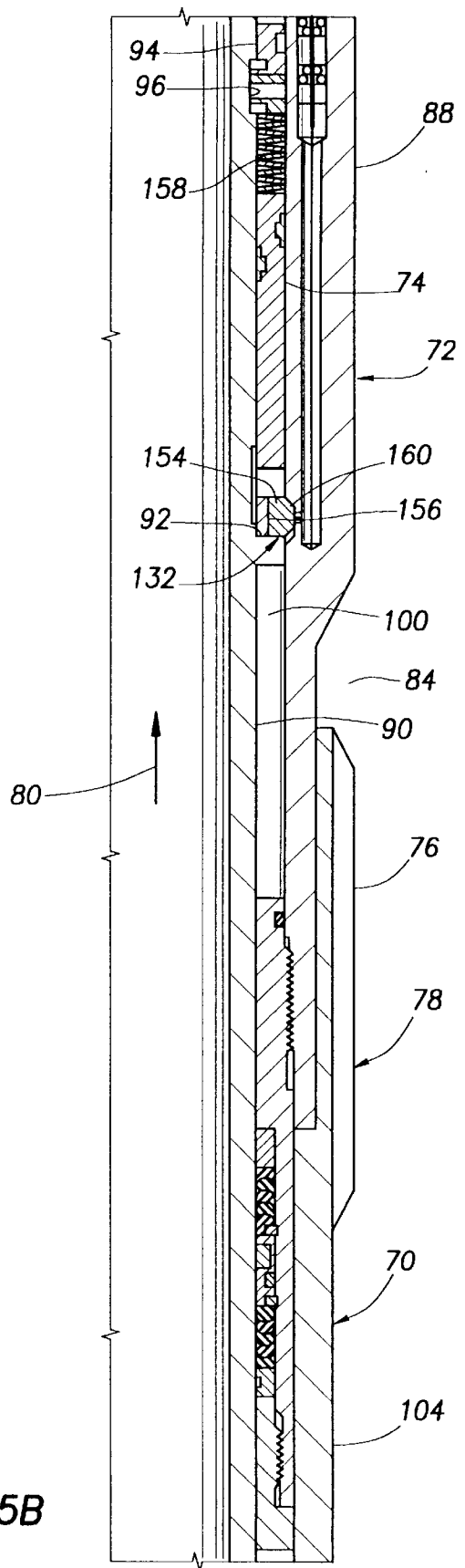

FIG.5C

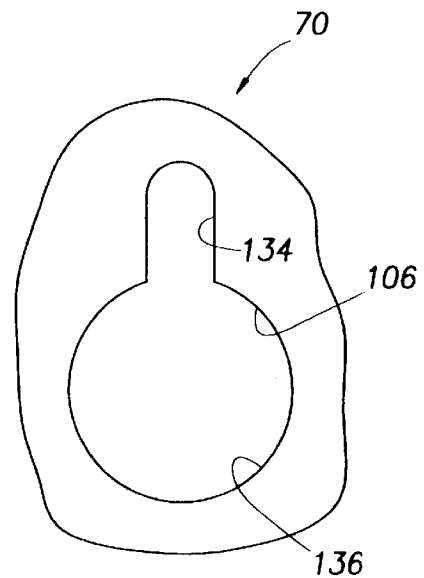
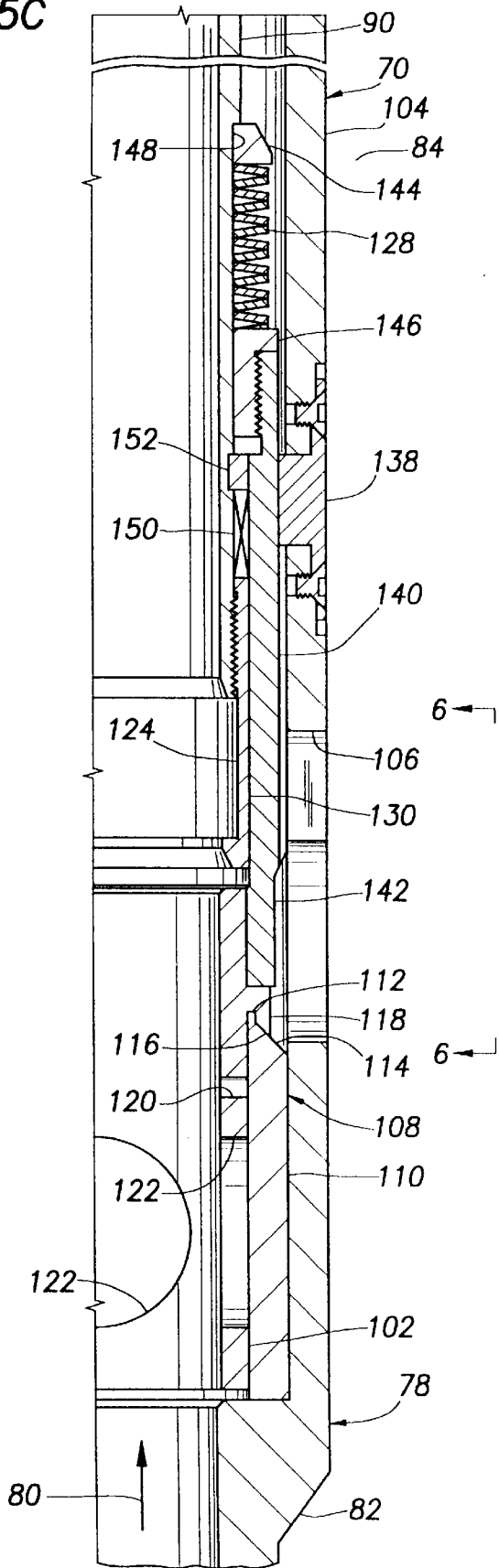

FIG.6

VARIABLE CHOKE FOR USE IN A SUBTERRANEAN WELL

CROSS-REFERENCE TO RELATED APPLICATIONS

This application is related to a copending application filed on even date herewith, entitled FLOW CONTROL APPARATUS having Mark A. Schnatzmeyer as an inventor thereof and an attorney docket number of 970332 U1 USA (application Ser. No. 08/898,504, filed Jul. 21, 1997). The disclosure of the copending application is incorporated herein by this reference.

BACKGROUND OF THE INVENTION

The present invention relates generally to apparatus utilized to control fluid flow in a subterranean well and, in an embodiment described herein, more particularly provides a choke for selectively regulating fluid flow into or out of a tubing string disposed within a well.

In a subsea well completion it is common for the well to be produced without having a rig or production platform on site. In this situation, it is well known that any problems that occur with equipment or other aspects of the completion may require a rig to be moved on site, in order to resolve the problem. Such operations are typically very expensive and should be avoided if possible.

An item of equipment needed, particularly in subsea completions, is a flow control apparatus which is used to throttle or choke fluid flow into a production tubing string. The apparatus would be particularly useful where multiple zones are produced and it is desired to regulate the rate of fluid flow into the tubing string from each zone. Additionally, regulatory authorities may require that rates of production from each zone be reported, necessitating the use of the apparatus or other methods of determining and/or controlling the rate of production from each zone. Safety concerns may also dictate controlling the rate of production from each zone.

Such an item of equipment would also be useful in single zone completions. For example, in a single wellbore producing from a single zone, an operator may determine that it is desirable to reduce the flow rate from the zone into the wellbore to limit damage to the well, reduce water coning and/or enhance ultimate recovery.

Downhole valves, such as sliding side doors, are designed for operation in a fully closed or fully open configuration and, thus, are not useful for variably regulating fluid flow therethrough. Downhole chokes typically are provided with a fixed orifice which cannot be closed. These are placed downhole to limit flow from a certain formation or wellbore. Unfortunately, conventional downhole valves and chokes are also limited in their usefulness because intervention is required to change the fixed orifice or to open or close the valve.

What is needed is a flow control apparatus which is rugged, reliable, and long-lived, so that it may be utilized in completions without requiring frequent service, repair or replacement. To compensate for changing conditions, the apparatus should be adjustable without requiring slickline, wireline or other operations which need a rig for their performance, or which require additional equipment to be installed in the well. The apparatus should be resistant to erosion, even when it is configured between its fully open and closed positions, and should be capable of accurately regulating fluid flow.

Such a downhole variable choking device would allow an operator to maximize reservoir production into the wellbore. It would be useful in surface, as well as subsea, completions, including any well where it is desired to control fluid flow, such as gas wells, oil wells, and water and chemical injection wells. In sum, in any downhole environment for controlling flow of fluids.

It is accordingly an object of the present invention to provide such a flow control apparatus which permits variable downhole flow choking as well as the ability to shut off fluid flow, and associated methods of controlling fluid flow within a subterranean well.

SUMMARY OF THE INVENTION

In carrying out the principles of the present invention, in accordance with an embodiment thereof, an apparatus is provided which is a choke for use within a subterranean well. The described choke provides ruggedness, simplicity, reliability and longevity in regulating fluid flow into or out of a tubing string within the well.

In broad terms, a choke is provided which includes a tubular inner cage, an outer housing and a choke member set. The cage is slidingly disposed within the housing and the choke member set is carried externally on the cage. Manipulation of the cage by a conventional actuator or shifting tool causes the choke member set to partially open, fully open, and close as desired.

The choke member set utilizes a design which both impedes erosion and wear of the choke components, and, in combination with the cage, permits commingling of fluids produced from multiple zones of the well, or control of fluids injected into multiple zones. Commingling of fluids produced, or control of fluids injected, may be precisely regulated by manipulation of the cage with the actuator.

These and other aspects, features, objects, and advantages of the present invention will be more fully appreciated following careful consideration of the detailed description and accompanying drawings set forth hereinbelow.

BRIEF DESCRIPTION OF THE DRAWINGS

FIGS. 1A-1B are quarter-sectional views of successive axial portions of a choke embodying principles of the present invention, the choke being shown in a configuration in which it is initially run into a subterranean well attached to an actuator and interconnected in a production tubing string;

FIG. 2 is a quarter-sectional view of an axial portion of the choke of FIGS. 1A-1B, the choke being shown in a configuration in which a choke member set has been partially opened;

FIG. 3 is a quarter-sectional view of an axial portion of the choke of FIGS. 1A-1B, the choke being shown in a configuration in which the choke member set has been fully opened;

FIG. 4 is an enlarged quarter-sectional view of an axial portion of the choke of FIGS. 1A-1B, the choke being shown in a configuration in which fluid flow through a port of the choke member set is partially restricted;

FIGS. 5A-5C are quarter-sectional views of successive axial portions of another choke embodying principles of the present invention, the choke being shown in a configuration in which it is initially run into a subterranean well attached to an actuator and interconnected in a production tubing string; and

FIG. 6 is an elevational view of an opening formed through an outer housing of the choke of FIGS. 5A-5C, as indicated by arrows 6-6.

DETAILED DESCRIPTION

Representatively illustrated in FIGS. 1A–1B is a choke **10** which embodies principles of the present invention. In the following description of the choke **10** and other apparatus and methods described herein, directional terms, such as “above”, “below”, “upper”, “lower”, etc., are used for convenience in referring to the accompanying drawings. Although the choke **10** and other apparatus, etc., shown in the accompanying drawings are depicted in successive axial sections, it is to be understood that the sections form a continuous assembly. Additionally, it is to be understood that the various embodiments of the present invention described herein may be utilized in various orientations, such as inclined, inverted, horizontal, vertical, etc., without departing from the principles of the present invention.

The choke **10** is sealingly attached to an actuator **12**, a lower portion of which is shown in FIG. 1A. In a manner which will be more fully described hereinbelow, the actuator **12** is used to operate the choke **10**. The actuator **12** may be hydraulically, electrically, mechanically, magnetically or otherwise controlled without departing from the principles of the present invention. The representatively illustrated actuator **12** is a SCRAMS ICV hydraulically controlled actuator manufactured by, and available from, PES, Incorporated of The Woodlands, Texas. It includes an actuator member or annular piston **14** which is axially displaceable relative to the choke **10** by appropriate hydraulic pressure applied to the actuator **12** via control lines (not shown) extending to the earth's surface.

In a method of using the choke **10**, the choke and actuator **12** are positioned within a subterranean well as part of a production tubing string **18** extending to the earth's surface. As representatively illustrated in FIGS. 1A–1B, fluid (indicated by arrows **20**) may flow axially through the choke **10** and actuator **12**, and to the earth's surface via the tubing string **18**. The fluid **20** may, for example, be produced from a zone of the well below the choke **10**. In that case, an additional portion of the tubing string **18** including a packer (not shown) would be attached in a conventional manner to a lower adaptor **22** of the choke **10** and set in the well in order to isolate the zone below the choke from other zones of the well, such as a zone in fluid communication with an area **24** surrounding the choke.

In a manner more fully described hereinbelow, the choke **10** enables accurate regulation of fluid flow between the external area **24** and an internal axial fluid passage **26** extending through the choke. In another method of using the choke **10**, multiple chokes may be installed in the tubing string **18**, with each of the chokes corresponding to a respective one of multiple zones intersected by the well, and with the zones being isolated from each other external to the tubing string. Thus, the choke **10** also enables accurate regulation of a rate of fluid flow from each of the multiple zones, with the fluids being commingled in the tubing string **18**.

It is to be understood that, although the tubing string **18** is representatively illustrated in the accompanying drawings with fluid **20** entering the lower adaptor **22** and flowing upwardly through the fluid passage **26**, the lower connector **22** may actually be closed off or otherwise isolated from such fluid flow in a conventional manner, such as by attaching a bull plug thereto, or the fluid **20** may be flowed downwardly through the fluid passage **26**, for example, in order to inject the fluid into a formation intersected by the well, without departing from the principles of the present invention. For convenience and clarity of description, the

choke **10** and associated tubing string **18** will be described hereinbelow as it may be used in a method of producing fluids from multiple zones of the well, the fluids being commingled within the tubing string, and it being expressly understood that the choke **10** may be used in other methods without departing from the principles of the present invention.

An upper portion **16** of the choke **10** is attached to the actuator **12**. As shown in FIG. 1B, the upper portion **16** is integrally formed with an outer housing **28** of the actuator **12**. However, it is to be understood that the choke **10** may be threadedly attached to the actuator **12**, or otherwise attached thereto without departing from the principles of the present invention. In that manner, the choke **10** may be used with other actuators, attached directly to the remainder of the tubing string **18**, etc.

The piston **14** is attached externally about an upper generally tubular operating mandrel **30** of the choke **10**. A retaining ring **32** extends radially inwardly from the piston **14** and engages an annular groove **34** formed externally on the mandrel **30**. Thus, axial displacement of the piston **14** by the actuator **12** will cause a corresponding axial displacement of the mandrel **30**.

The mandrel **30** is axially reciprocally and sealingly received in the actuator **12**. Circumferential seals **36** sealingly engage the mandrel **30** externally and permit fluid isolation between two chambers **38**, **40**. In this manner, it may be considered that the mandrel **30** becomes a part of the actuator **12**, but it is to be clearly understood that it is not necessary, in keeping with the principles of the present invention, for the mandrel **30** to form a part of the actuator **12**.

To operate the choke **10**, the mandrel **30** is axially displaced relative to the upper portion **16**, in order to axially displace an inner axially extending and generally tubular cage member **42** relative to an outer housing **44** of the choke. The mandrel **30** is sealingly interconnected to the cage **42** by shrink fitting it thereto, although any other suitable connection method, such as brazing, threading, integrally forming, etc., may be utilized without departing from the principles of the present invention. The applicants use shrink fitting since, in the representatively illustrated embodiment of the invention, the cage **42** is made of a highly erosion resistant material, such as carbide, while the mandrel **30** is made of an alloy steel.

Axial displacement of the mandrel **30** is accomplished by applying fluid pressure to one of the chambers **38**, **40** to thereby apply an axially directed biasing force to the piston **14**. For example, if it is desired to displace the mandrel **30** axially upward to permit fluid flow through the choke **10** or to decrease resistance to fluid flow therethrough, fluid pressure may be applied to the lower chamber **40**. Conversely, if it is desired to downwardly displace the mandrel **30** to prevent fluid flow through the choke **10** or to increase resistance to fluid flow therethrough, fluid pressure may be applied to the upper chamber **38**.

The housing **44** includes a series of axially elongated and circumferentially spaced apart openings **46**, only one of which is visible in FIG. 1B. The openings **46** are formed through a sidewall portion of the housing **44** and thereby provide fluid communication between the area **24** external to the choke **10** and the interior of the housing. The housing **44** is integrally formed with the upper portion **16**, and is threadedly and sealingly attached to the lower adaptor **22**, with the openings **46** being positioned axially between the upper portion **16** and the lower adaptor.

A choke member set **48** is disposed within the outer housing **44** and includes a portion of a sleeve **50** received sealingly within the outer housing. As used herein, the term "choke member set" is used to describe an element or combination of elements which perform a function of regulating fluid flow. In the illustrated embodiment of the invention, the choke member set **48** includes an upper portion of the sleeve **50** and portions of the cage **42**, which will be more fully described hereinbelow. The applicants prefer that the choke member set **48** be configured in some respects similar to those utilized in a Master Flo Flow Trim manufactured by, and available from, Master Flo of Ontario, Canada, although other choke member sets may be utilized without departing from the principles of the present invention.

The sleeve **50** is sealingly received in the housing **44** by shrink fitting it therein. Of course, other methods of sealingly attaching the sleeve **50** may be utilized without departing from the principles of the present invention. For example, the sleeve **50** could be threaded into the housing **44**, brazed therein, etc.

The sleeve **50** includes an axially extending and internally inclined lip **52** adjacent an externally inclined seal surface **54**. The lip **52** acts to prevent, or at least greatly reduce, erosion of the seal surface **54**, among other benefits. The seal surface **54** is cooperatively shaped to sealingly engage a seal surface **56** internally formed on a seat **58**, which is externally carried on the cage **42** and integrally formed therewith. In the configuration of the choke **10** shown in FIG. 1B, the seal surface **54** is contacting and sealingly engaging the seal surface **56**. Preferably, the seal surfaces **54, 56** are formed of hardened metal or carbide for erosion resistance, although other materials may be utilized without departing from the principles of the present invention. Additionally, the seat **58**, which includes the seal surface **56**, may be wholly or partially formed of hardened metal or carbide, and may be separately formed from the cage **42**.

The cage **42** has a set of flow ports **60**, and a set of comparatively larger flow ports **62**, formed radially therethrough. Each of the sets of ports **60, 62** includes two circumferentially spaced apart and oppositely disposed ports, although only one of each is visible in FIG. 1B. Of course, other numbers of ports may be utilized in the flow port sets **60, 62** without departing from the principles of the present invention. In the configuration of the choke **10** shown in FIG. 1B, the upper ports **60** and lower ports **62** are radially outwardly overlaid by the sleeve **50**, and the seal surfaces **54, 56** are sealingly engaged. Thus, fluid communication between the external area **24** and the flow passage **26** through the flow ports **60, 62** is prevented by the sleeve **50**.

As representatively illustrated in the accompanying drawings, the flow ports **60** are comparatively small, in order to provide an initial relatively highly restricted fluid flow therethrough when the cage **42** is displaced axially upward to permit fluid flow between the seal surfaces **54, 56**, as more fully described hereinbelow. However, it is to be understood that the flow ports **60** may be otherwise dimensioned, otherwise positioned, otherwise dimensioned with respect to each other, and otherwise positioned with respect to each other, without departing from the principles of the present invention. For example, the upper flow ports **60** may actually have larger or smaller diameters, may have larger or smaller diameters than the lower flow ports **62**, may be positioned differently on the cage **42**, and may be positioned differently with respect to the lower flow ports. Similar changes may be made to the lower flow ports **62**. Indeed, it is not necessary for the cage **42** to have differently config-

ured sets of flow ports **60, 62** at all. Thus, the flow port sets **60, 62** shown in the accompanying drawings are merely illustrative and additions, modifications, deletions, substitutions, etc., may be made thereto without departing from the principles of the present invention.

As shown in FIG. 1B, the cage **42** is prevented from displacing axially downward relative to the sleeve **50** by axial contact between the seal surfaces **54, 56**. Such axial contact may be maintained by maintaining fluid pressure in the chamber **38** of the actuator **12**. It will be readily apparent to a person of ordinary skill in the art that such axial contact may also be maintained by provision of a biasing member (not shown), which applies an axially downward biasing force to the mandrel **30** or cage **42**. For example, a compression spring may be installed in the chamber **38** to apply a downwardly directed biasing force to the piston **14** and, therefore, to the mandrel **30**. However, applicants prefer that the cage **42** not be biased into axial contact with the sleeve **50**, so that the choke **10** may be opened and remain open in the event that a failure should be experienced in the actuator **12**. For displacement of the mandrel **30** and cage **42** in the event of such a failure, a conventional shifting profile **64** is internally formed on the mandrel **30**, which may be engaged by a shifting tool (not shown) conveyed on wireline, slickline, coiled tubing, etc., in a conventional manner. Of course, other profiles and methods of displacing the mandrel **30** and/or cage **42** may be utilized without departing from the principles of the present invention. Additionally, other methods of maintaining the cage **42** in a desired position relative to the housing **44** may be utilized without departing from the principles of the present invention. For example, detents, etc., may be configured to cooperatively engage the cage **42** and/or housing **44**.

If the cage **42** is displaced axially upward relative to the sleeve **50** and housing **44**, the seal surfaces **54, 56** will disengage and fluid flow will be permitted between the external area **24** and the fluid passage **26**. Thus, the choke member set **48** is selectively openable by axially displacing the cage **42** upward from its position shown in FIG. 1B. The choke member set **48** may be maintained in an open position by, for example, a latching device (not shown).

Referring additionally now to FIG. 2, an axial portion of the choke **10** is representatively illustrated in a configuration in which the upper flow ports **60** are exposed to direct fluid flow between the area **24** and the fluid passage **26**. In this configuration, the cage **42** has been axially upwardly displaced relative to the housing **44** and sleeve **50**. The seal surfaces **54, 56** are no longer sealingly engaged, thus permitting fluid communication between the area **24** and the fluid passage **26**.

It will be readily apparent to a person of ordinary skill in the art that, with suitable modification, e.g., interchanging the cage **42** and sleeve **50**, the sleeve may instead be displaced relative to the cage, to permit fluid communication between the area **24** and the fluid passage **26**. Alternatively, both the cage **42** and sleeve **50** could be displaced relative to the housing **44** and to each other. No matter the manner in which relative displacement occurs between the cage **42** and sleeve **50**, such relative displacement permits variable choking of fluid flow through the flow ports **60, 62** and sealing engagement between the seal surfaces **54, 56** when desired.

The sleeve **50** is preferably closely fitted externally about the cage **42**. Thus, fluid (indicated by arrows **66**) from the area **24** flows almost exclusively through the smaller upper flow ports **60**, even though some fluid may pass between the

sleeve 50 and cage 42 to flow through the larger lower flow ports 62. The fluid 66 may commingle in the fluid passage 26 with fluid 20 from another portion of the well, or, alternatively, if an injection operation is performed, the fluids may be oppositely directed and the fluid 66 would then represent a portion of the injected fluid which passes outwardly through the openings 46 from the fluid passage 26.

It is a particular benefit of the present invention that the fluids 20, 66 may be commingled within the fluid passage 26, and the rate of flow of each may be accurately regulated utilizing one or more of the chokes 10 as described hereinabove. For example, another choke, similar to the illustrated choke 10, may be installed below the choke 10 to regulate the rate of flow of the fluid 20, while the choke 10 regulates the rate of flow of the fluid 66. Alternatively, where the choke 10 is used in an injection operation, the choke may be utilized to regulate the rate of fluid flow outward through the flow ports 60, 62, and, alone or in combination with additional chokes, may be utilized to accurately regulate fluid flow rates into multiple zones in a well. Of course, the choke 10 may also be useful in single zone completions to regulate fluid flow into or out of the zone.

Referring additionally now to FIG. 3, an axial portion of the choke 10 is representatively illustrated in a fully open configuration in which the cage 42 is further axially upwardly displaced as compared to that shown in FIG. 2, completely uncovering both of the flow port sets 60, 62. The fluid 66 is, thus, permitted to flow unobstructed inwardly through the flow port sets 60, 62 and into the fluid passage 26. The cage 42 has been rotated ninety degrees about its longitudinal axis, so that it may be clearly seen that the ports 62 are now aligned with the openings 46. Therefore, upward displacement of the cage 42 both uncovers the ports 62 and aligns the ports with the openings 46 of the housing 44.

Preferably, the ports 62 are directly aligned with the openings 46 in the fully open configuration of the choke 10 and, furthermore, it is preferred that the ports 62 and openings 46 are similarly sized in order to minimize resistance to flow therethrough, reduce friction losses and minimize erosion of the choke 10. However, it is to be clearly understood that it is not necessary in keeping with the principles of the present invention for the ports 62 to be directly aligned with the openings 46, nor for the ports 62 to be identical in size, shape or number with the openings 46. If the ports 62 are not aligned with the openings 46 in the fully open configuration of the choke 10, then preferably a sufficiently large annular space is provided between the exterior of the cage 42 and the interior of the housing 44 so that fluid flow therebetween has minimum resistance.

Although FIG. 3 representatively illustrates the cage 42 rotated so that the ports 62 are directly aligned with the openings 46, it is to be clearly understood that such rotation is not necessary in operation of the choke 10. However, to achieve such direct alignment between the ports 62 and openings 46, the cage 42 and/or mandrel 30 may be rotationally secured to the housing 44 in a manner which prevents misalignment between the ports and openings. For example, a radially outwardly extending projection or key (not shown) may be provided on the cage 42 and/or mandrel 30 and cooperatively slidingly engaged with a groove or keyway (not shown) formed internally on the housing 44 and/or actuator 12, sleeve 50, etc., to thereby prevent relative circumferential displacement between the cage and housing.

It will be readily apparent to one of ordinary skill in the art that the relative proportions of the fluids 20, 66 produced

through the tubing string 18 may be conveniently regulated by selectively permitting greater or smaller fluid flow rates through the choke member set 48. With fluid flow substantially restricted through the ports 60, 62 by the sleeve 50, the fluid produced through the tubing string 18 may have a greater proportion of the fluid 20. With fluid flow being unobstructed through the choke member set 48, the fluid produced through the tubing string 18 may have a greater proportion of the fluid 66.

Referring additionally now to FIG. 4, an enlarged axial portion of the choke 10 is representatively illustrated with the cage 42 in an intermediate position in which the lip 52 on the sleeve 50 is overlying the lower flow ports 62. Thus, fluid flow through the lower flow ports 62 is restricted by the sleeve 50, and fluid flow through the upper flow ports 60 is not restricted by the sleeve. It will be readily apparent to a person of ordinary skill in the art that fluid flow through the flow ports 62 may be variably choked or restricted by correspondingly variably displacing the flow ports 62 relative to the sleeve 50. In other words, if the cage 42 is displaced axially upward somewhat from its position as shown in FIG. 4, fluid flow through the flow ports 62 will be correspondingly less restricted, and if the cage is displaced axially downward somewhat, fluid flow through the flow ports will be correspondingly more restricted. It will also be readily apparent that there are an infinite number of positions of the cage 42 relative to the sleeve 50 in which fluid flow is permitted through the choke member set 48.

The lip 52 is disposed partially obstructing the flow ports 62. It is believed that the presence of the lip 52 extending outwardly from the sleeve 50 acts to reduce erosion of the sleeve, particularly the seal surface 54, and also aids in reducing erosion of the cage 42 adjacent the flow ports 60, 62 when the fluid 66 is flowing therethrough. The lip 52 deflects the fluid flow path away from the seal surface 54.

Additionally, it is believed that the diametrically opposite orientation of the individual ports of each of the flow port sets 60, 62 acts to reduce erosion of the cage 42, in that inwardly directed fluid 66 flowing through one of two diametrically opposing ports will interfere with, or impinge on, the fluid flowing inwardly through the other port, thereby causing the fluid velocity to decrease and, accordingly, cause the fluid's kinetic energy to decrease. Thus, the impinging fluid flows in the center of the cage 42 dissipates the fluid energy onto itself and reduces erosion by containing turbulence and throttling wear within the cage. The sealing surfaces 54, 56 are isolated from the flow paths and sealing integrity is maintained, even though erosion may take place at the ports 60, 62.

Preferably, each of the flow port sets 60, 62 includes individual ports of equal diameter provided in pairs, as shown in the accompanying drawings, or greater numbers, as long as the geometry of the ports is arranged so that impingement results between fluid flowing through the ports, and so that such impingement occurs at or near the center of the cage 42 and away from the seal surfaces 54, 56, ports, and other flow controlling elements of the choke 10. As an example of alternate preferred arrangements of the flow port set 62, three ports of equal size and geometry could be provided, spaced around the circumference of the cage 42 at 120 degrees apart from each other, or four ports of equal size and geometry could be provided, spaced around the circumference of the cage at 90 degrees apart from each other, etc.

It is a particular benefit of the embodiment of the invention described herein that portions thereof may erode during

normal use, without affecting the ability of the choke **10** to be closed to fluid flow therethrough. For example, the lip **52**, the flow port sets **60, 62** and the interior of the cage **42**, etc., may erode without damaging the seal surfaces **54, 56**. Thus, where it is important for safety purposes to ensure the fluid tight sealing integrity of the wellbore, the choke **10** preserves its ability to shut off fluid flow therethrough even where its fluid choking elements have been degraded.

Thus has been described the choke **10** and methods of controlling fluid flow within the well using the choke, which provide reliability, ruggedness, longevity, and do not require complex mechanisms. Of course, modifications, substitutions, additions, deletions, etc., may be made to the exemplary embodiment described herein, which changes would be obvious to one of ordinary skill in the art, and such changes are contemplated by the principles of the present invention. For example, the operating mandrel **30** may be releasably attached to the actuator piston **14**, so that, if the actuator **12** becomes inoperative, the cage **42** may be displaced independently from the piston. As another example, the cage **42** may be displaced circumferentially or radially, rather than axially, in order to selectively open choke member sets positioned radially about the cage, rather than being positioned axially relative to the cage. Accordingly, the foregoing detailed description is to be clearly understood as being given by way of illustration and example only, the spirit and scope of the present invention being limited solely by the appended claims.

Referring additionally now to FIGS. **5A-5C** another choke **70** which embodies principles of the present invention is representatively illustrated. The choke **70** is sealingly attached to an actuator **72**, a lower portion of which is shown in FIG. **1A**. In a manner which will be more fully described hereinbelow, the actuator **72** is used to operate the choke **70**. The actuator **72** may be hydraulically, electrically, mechanically, magnetically or otherwise controlled without departing from the principles of the present invention. The representatively illustrated actuator **72** is the SCRAMS ICV hydraulically controlled actuator referred to above. It includes an actuator member or annular piston **74** which is axially displaceable relative to the choke **70** by appropriate hydraulic pressure applied to the actuator **72** via control lines (not shown) extending to the earth's surface.

In a method of using the choke **70**, the choke and actuator **72** are positioned within a subterranean well as part of a production tubing string **78** extending to the earth's surface. As representatively illustrated in FIGS. **5A-5C**, fluid (indicated by arrows **80**) may flow axially through the choke **70** and actuator **72**, and to the earth's surface via the tubing string **78**. The fluid **80** may, for example, be produced from a zone of the well below the choke **70**. In that case, an additional portion of the tubing string **78** including a packer (not shown) may be attached in a conventional manner to a lower adaptor **82** of the choke **70** and set in the well in order to isolate the zone below the choke from other zones of the well, such as a zone in fluid communication with an area **84** surrounding the choke.

In a manner similar to that described hereinabove for the choke **10**, the choke **70** enables accurate regulation of fluid flow between the external area **84** and an internal axial fluid passage **86** extending through the choke. In another method of using the choke **70**, multiple chokes may be installed in the tubing string **18**, with each of the chokes corresponding to a respective one of multiple zones intersected by the well, and with the zones being isolated from each other external to the tubing string. Thus, the choke **70** also enables accurate regulation of a rate of fluid flow from each of the multiple zones, with the fluids being commingled in the tubing string **78**.

It is to be understood that, although the tubing string **78** is representatively illustrated in the accompanying drawings with fluid **80** entering the lower adaptor **82** and flowing upwardly through the fluid passage **86**, the lower adaptor **82** may actually be closed off or otherwise isolated from such fluid flow in a conventional manner, such as by attaching a bull plug thereto, or the fluid **80** may be flowed downwardly through the fluid passage **86**, for example, in order to inject the fluid into a formation intersected by the well, without departing from the principles of the present invention. For convenience and clarity of description, the choke **70** and associated tubing string **78** will be described hereinbelow as it may be used in a method of producing fluids from multiple zones of the well, the fluids being commingled within the tubing string, and it being expressly understood that the choke **70** may be used in other methods without departing from the principles of the present invention.

An upper portion **76** of the choke **70** is attached to the actuator **72**. The upper portion **76** may be integrally formed with an outer housing **88** of the actuator **72**. Alternatively, the choke **70** may be threadedly attached to the actuator **72**, or otherwise attached thereto without departing from the principles of the present invention. In that manner, the choke **70** may be used with other actuators, attached directly to the remainder of the tubing string **78**, etc.

The piston **74** is attached externally about an upper generally tubular operating mandrel **90** of the choke **70**. The piston **74** is retained axially between a radially enlarged external shoulder **92** formed on the mandrel **90** and a ring **94** secured with respect to a circumferential groove **96** externally formed on the mandrel. In substantial part, axial displacement of the piston **74** by the actuator **72** will cause a corresponding axial displacement of the mandrel **90**. However, in a manner that will be more fully described below, a portion of axial displacement of the piston **74** may be utilized in selectively locking or unlocking the mandrel **90** in its position with respect to the remainder of the choke **70**.

The piston **74** is slidingly and sealingly engaged with the exterior surface of the mandrel **90** and with the interior surface of the housing **88** of the actuator **72**. In this manner, the piston **74** provides fluid isolation between two chambers **98, 100** formed radially between the housing **88** and the mandrel **90**. It may be considered that the mandrel **90** becomes a part of the actuator **72**, since the mandrel in part encloses the chambers **98, 100** and sealingly engages the piston **74**, but it is to be clearly understood that it is not necessary, in keeping with the principles of the present invention, for the mandrel **90** to form a part of the actuator **72**.

Axial displacement of the mandrel **90** is accomplished by applying fluid pressure to one of the chambers **98, 100** to thereby apply an axially directed biasing force to the piston **74** and, thus, to the mandrel. For example, if it is desired to displace the mandrel **90** axially upward to permit fluid flow through the choke **70** or to decrease resistance to fluid flow therethrough, fluid pressure may be applied to the lower chamber **100**. Conversely, if it is desired to downwardly displace the mandrel **90** to prevent fluid flow through the choke **70** or to increase resistance to fluid flow therethrough, fluid pressure may be applied to the upper chamber **98**.

To operate the choke **70**, the mandrel **90** is axially displaced relative to the upper portion **76**, in order to axially displace an inner axially extending and generally tubular cage member **102** relative to an outer housing **104** of the choke. The mandrel **90** is interconnected to the cage **102** in

a manner that permits a biasing force to be applied to the cage without the need of applying or maintaining fluid pressure in either of the actuator's fluid chambers **98**, **100**. Such interconnection will be more fully described below.

The housing **104** includes a series of axially elongated and circumferentially spaced apart openings **106**, only one of which is visible in FIG. **1B**. The openings **106** are formed through a sidewall portion of the housing **104** and thereby provide fluid communication between the area **84** external to the choke **70** and the interior of the housing. The housing **104** is integrally formed with the upper portion **76** and the lower adaptor **82**, with the openings **106** being positioned axially between the upper portion and the lower adaptor.

A choke member set **108** is disposed within the outer housing **104** and includes a portion of a sleeve **110** received sealingly within the outer housing. As used herein, the term "choke member set" is used to describe an element or combination of elements which perform a function of regulating fluid flow. In the illustrated embodiment of the invention, the choke member set **108** includes an upper portion of the sleeve **110** and portions of the cage **102**, which will be more fully described hereinbelow. The applicants prefer that the choke member set **108** be configured in some respects similar to those utilized in the Master Flo Flow Trim referred to above, although other choke member sets may be utilized without departing from the principles of the present invention.

The sleeve **110** is preferably manufactured of an erosion resistant material, such as carbide, and is sealingly received in the housing **104** by shrink fitting it therein. Of course, other methods of sealingly attaching the sleeve **110** may be utilized without departing from the principles of the present invention. For example, the sleeve **110** could be threaded into the housing **104**, brazed therein, etc.

The sleeve **110** includes an axially extending and internally inclined lip **112** adjacent an externally inclined seal surface **114**. The lip **112** acts to prevent, or at least greatly reduce, erosion of the seal surface **114**, among other benefits. The seal surface **114** is cooperatively shaped to sealingly engage a seal surface **116** internally formed on a seat **118**, which is externally carried on the cage **102** and integrally formed therewith. In the configuration of the choke **70** shown in FIG. **5B**, the seal surface **114** is contacting and sealingly engaging the seal surface **116**. Preferably, the seal surfaces **114**, **116** are formed of hardened metal or carbide for erosion resistance, although other materials, such as resilient materials, may be utilized without departing from the principles of the present invention. Additionally, the seat **118**, which includes the seal surface **116**, may be wholly or partially formed of hardened metal or carbide, and may be separately formed from the cage **102** and sealingly attached thereto, etc.

The cage **102** has a set of comparatively small flow ports **120**, and a set of comparatively larger flow ports **122**, formed radially therethrough. The set of ports **120** includes two circumferentially spaced apart and oppositely disposed ports, although only one is visible in FIG. **5C**, and the set of ports **122** includes four equally circumferentially spaced apart ports, although only two are visible in FIG. **9C**. Of course, other numbers of ports may be utilized in the flow port sets **120**, **122** without departing from the principles of the present invention. In the configuration of the choke **70** shown in FIG. **5C**, the upper ports **120** and lower ports **122** are radially outwardly overlaid by the sleeve **110**, and the seal surfaces **114**, **116** are sealingly engaged. Thus, fluid communication between the external area **84** and the flow

passage **86** through the flow ports **120**, **122** is prevented by the sleeve **110**.

As representatively illustrated in the accompanying drawings, the flow ports **120** are comparatively small, in order to provide an initial relatively highly restricted fluid flow therethrough when the cage **102** is displaced axially upward to permit fluid flow between the seal surfaces **114**, **116**, as more fully described hereinbelow. However, it is to be understood that the flow ports **120**, **122** may be otherwise dimensioned, otherwise shaped (e.g., elliptical, oval, square, oblong, etc.), otherwise positioned, otherwise dimensioned with respect to each other, and otherwise positioned with respect to each other, without departing from the principles of the present invention. For example, the upper flow ports **120** may actually have larger or smaller dimensions, may have larger or smaller dimensions than the lower flow ports **122**, may be positioned differently on the cage **102**, and may be positioned differently with respect to the lower flow ports. Similar changes may be made to the lower flow ports **122**. Indeed, it is not necessary for the cage **102** to have differently configured sets of flow ports **120**, **122** at all. Thus, the flow port sets **120**, **122** shown in the accompanying drawings are merely illustrative and additions, modifications, deletions, substitutions, etc., for example, by making one or more of the ports oval, elliptical, triangular, or otherwise shaped, may be made thereto without departing from the principles of the present invention.

As shown in FIGS. **5A-5C**, the cage **102** is prevented from displacing axially downward relative to the sleeve **110** by axial contact between the seal surfaces **114**, **116**. Such axial contact may be maintained by maintaining fluid pressure in the chamber **98** of the actuator **72**. It will be readily apparent to a person of ordinary skill in the art that such axial contact may also be maintained by provision of a biasing device **128**, which applies an axially downward biasing force to the cage **102**. Operation of the biasing device **128** in maintaining axial contact between the seal surfaces **114**, **116** will be more fully described hereinbelow.

For displacement of the mandrel **90** and cage **102** in the event of a failure of the actuator **72**, conventional shifting profiles **124** are internally formed on the mandrel **90** and a mandrel extension **130** threadedly attached to a lower end of the mandrel. Either of the shifting profiles **124** may be engaged by a shifting tool (not shown) conveyed on wireline, slickline, coiled tubing, etc., in a conventional manner. Of course, other profiles and methods of displacing the mandrel **90** and/or cage **102** may be utilized without departing from the principles of the present invention. Additionally, other methods of maintaining the cage **102** in a desired position relative to the housing **104** and/or sleeve **110** may be utilized without departing from the principles of the present invention. For example, detents, etc., may be configured to cooperatively engage the cage **102** and/or housing **104**. For this purpose, a locking mechanism **132** is provided in the choke **70**, and will be more fully described below.

If the cage **102** is displaced axially upward relative to the sleeve **110** and housing **104**, the seal surfaces **114**, **116** will disengage and fluid flow will be permitted between the external area **84** and the fluid passage **86**. Thus, the choke member set **108** is selectively openable by axially displacing the cage **102** upward from its position shown in FIG. **5C**. The choke member set **108** may be maintained in an open position by, for example, a latching device (not shown). A suitable latching device is shown and described in the copending application having an attorney docket no. of 970331 U1 USA.

It will be readily apparent to a person of ordinary skill in the art that, with suitable modification, e.g., interchanging the cage **102** and sleeve **110**, the sleeve may instead be displaced relative to the cage, to permit fluid communication between the area **84** and the fluid passage **86**. Alternatively, both the cage **102** and sleeve **110** could be displaced relative to the housing **104** and to each other. No matter the manner in which relative displacement occurs between the cage **102** and sleeve **110**, such relative displacement permits variable choking of fluid flow through the flow ports **120**, **122** and sealing engagement between the seal surfaces **114**, **116** when desired in a manner similar to that described above for the choke **10**.

Preferably, the ports **120,122** are directly aligned with the openings **106** in the fully open configuration of the choke **70** and, furthermore, it is preferred that the combined ports **120,122** and openings **106** are similarly sized in order to minimize resistance to flow therethrough, reduce friction losses and minimize erosion of the choke **70**. Referring additionally now to FIG. **6**, an elevational view of one of the openings **106** is representatively illustrated. The opening **106** shown in FIG. **6** has a generally axially extending upper portion **134** and a generally circular shaped lower portion **136**. When the choke member set **108** is in its fully open position, the comparatively small flow ports **120** are positioned radially opposite the comparatively small upper portions **134** of the openings **106**, and the comparatively large flow ports **122** are positioned radially opposite the comparatively large lower portions **136** of the openings. In this manner, the openings **106** are conformed in relation to the dimensions and orientations of the flow port sets **120**, **122** to aid in minimizing erosion of various elements of the choke **70**.

However, it is to be clearly understood that it is not necessary in keeping with the principles of the present invention for the ports **120**, **122** to be directly aligned with the openings **106**, nor for the ports **120**, **122** to be identical in size, shape or number with the openings **106**. If the ports **120**, **122** are not aligned with the openings **106** in the fully open configuration of the choke **70**, then preferably a sufficiently large annular space is provided between the exterior of the cage **102** and the interior of the housing **104** so that fluid flow therebetween has minimum resistance.

In order to achieve such alignment between the ports **120**, **122** and openings **106** in the representatively illustrated choke **70**, the cage **102** is rotationally secured to the housing **104** in a manner which prevents misalignment between the ports and openings. Specifically, an alignment key **138** extends radially through, and is fastened to, the outer housing **104** and axially slidingly engages a slotted recess **140** formed externally on a generally tubular cage extension **142** attached to the cage **102** and extending axially upward therefrom. The cage extension **142** is sealingly attached to the cage **102** by shrink fitting it thereto, although any other suitable connection method, such as brazing, threading, integrally forming, etc., may be utilized without departing from the principles of the present invention. The applicants use shrink fitting since, in the representatively illustrated embodiment of the invention, the cage **102** is made of a highly erosion resistant material, such as carbide, while the cage extension **142** is made of an alloy steel, although other materials may be used. Thus, engagement of the key **138** with the slotted recess **140** prevents circumferential displacement of the cage **102** relative to the housing **104**, but permits axial displacement of the cage relative to the housing.

The cage **102** is attached to the mandrel **90** in a manner that permits the biasing device **128** to exert a biasing force

on the cage, so that the sealing surfaces **114**, **116** remain sealingly engaged when the choke member set **108** is in its closed position as shown in FIG. **5C**. The biasing device **128** is representatively illustrated as a stack of belleville springs, although other biasing devices, such as coil springs, resilient members, etc., may be utilized without departing from the principles of the present invention. The biasing device **128** is axially retained between an upper ring **144** and a lower ring **146**, which are slidingly disposed on a radially reduced lower portion **148** formed externally on the mandrel **90**. The lower ring **146** is threadedly attached to the cage extension **142**. Thus, axially downward displacement of the mandrel **90** after the sealing surfaces **114**, **116** have contacted, will cause the biasing device **128** to be compressed axially between the rings **144**, **146**, and will apply a downwardly directed biasing force to the cage **102** via the cage extension **142**.

A seal or packing stack **150** provides sealing engagement radially between the mandrel **90** and the cage extension **142**, while permitting relative axial displacement therebetween. The seal **150** is axially retained between an expandable ring **152** installed in an annular groove formed on the radially reduced portion **148**, and the mandrel extension **124**.

The locking mechanism **132** permits the mandrel **90** to be releasably secured in its axial position relative to the housing **104**, after the mandrel has been axially downwardly displaced so that the sealing surfaces **114**, **116** contact, and after the mandrel has been further downwardly displaced so that the biasing device **128** exerts a downwardly biasing force on the cage **102** as described above and shown in FIG. **5C**. In this manner, the biasing force will be maintained, even though fluid pressure in the upper chamber **98** of the actuator **72** may be intentionally relieved or accidentally lost.

The locking mechanism **132** includes a radially expandable ring **154**, which is radially outwardly retained by a radially reduced lower portion **156** formed on the piston **74**. The piston **74** is biased downwardly, so that the lower portion **156** radially outwardly extends the ring **154**, by a biasing device **158**, which is representatively illustrated as a stack of belleville springs. The biasing device **158** is axially retained between the ring **94** and the piston **74**.

When radially outwardly extended as shown in FIG. **5B**, the ring **154** engages a radially enlarged groove **160** formed internally on the actuator housing **88** and abuts the shoulder **92** on the mandrel **90**. Such engagement between the ring **154** and the groove **160** prevents axially upward displacement of the mandrel **90** relative to the housing **104**. Thus, with the mandrel **90** in its position as shown in FIGS. **5A-5C**, the biasing device **128** is biasing the sealing surfaces **114,116** toward sealing engagement with each other, the biasing device **158** is biasing the piston **74** to extend the ring **154** into engagement with the groove **160**, and the mandrel **90** is prevented from displacing axially upward.

To radially inwardly retract the ring **154** and thereby disengage the ring from the groove **160**, fluid pressure may be applied to the lower chamber **100**, which is in fluid communication with the piston **74**, and which will bias the piston upwardly against the biasing force exerted by the biasing device **158**. When sufficient fluid pressure has been applied to the chamber **100** to overcome the biasing force exerted by the biasing device **158**, the piston **74** will displace upwardly, thereby permitting the ring **154** to radially inwardly retract out of engagement with the groove **160**. Such fluid pressure will also bias the mandrel **90** upwardly, causing the mandrel to displace upwardly, eventually removing the biasing force exerted by the biasing device **128** from the cage **102**.

When it is again desired to lock the mandrel **90** in its position relative to the housing **104**, fluid pressure may be relieved from the lower chamber **100** and applied to the upper chamber **98** to thereby bias the mandrel downwardly. When the ring **154** is radially opposite the groove **160**, the biasing force exerted by the biasing device **158**, in addition to the biasing force resulting from any fluid pressure in the upper chamber **98**, will cause the lower portion **156** of the piston to radially outwardly extend the ring into engagement with the groove **160**. Of course, it will be readily apparent to one of ordinary skill in the art that the biasing device **158** continually exerts a downwardly biasing force on the piston **74**, while fluid pressures in the chambers **98**, **100** only exert biasing forces on the piston when those fluid pressures are applied to the chambers. Thus, an operator may apply fluid pressure to the upper chamber **98** to close the choke member set **108** and to apply a biasing force to the choke member set so that the sealing surfaces **114**, **116** remain sealingly engaged, and then relieve the fluid pressure from the upper chamber while the mandrel remains locked in its position relative to the housing. Thereafter, when it is desired to open the choke member set **108**, the operator may apply fluid pressure to the lower chamber **100** to permit relative displacement between the mandrel **90** and the housing **104**.

Thus has been described the choke **70** and methods of controlling fluid flow within the well using the choke, which provide reliability, ruggedness, longevity, and do not require complex mechanisms. Of course, modifications, substitutions, additions, deletions, etc., may be made to the exemplary embodiment described herein, which changes would be obvious to one of ordinary skill in the art, and such changes are contemplated by the principles of the present invention. For example, the operating mandrel **90** may be releasably attached to the actuator piston **74**, so that, if the actuator **72** becomes inoperative, the cage **102** may be displaced independently from the piston. As another example, the cage **102** may be displaced circumferentially or radially, rather than axially, in order to selectively open choke member sets positioned radially about the cage, rather than being positioned axially relative to the cage. As a further example, a series of lugs, keys or collets may be utilized in place of the expandable ring **154** in the locking mechanism **132**. Accordingly, the foregoing detailed description is to be clearly understood as being given by way of illustration and example only, the spirit and scope of the present invention being limited solely by the appended claims.

What is claimed is:

1. A flow control apparatus operatively positionable within a subterranean well, the apparatus comprising:
 - a first member; and
 - a second member having a port for flow of fluid, fluid flow through the port being regulatable by displacement of the first member relative to the second member.
2. The flow control apparatus according to claim 1, wherein the first and second members are sealingly engageable to prevent fluid flow through the port.
3. The flow control apparatus according to claim 2, further comprising a biasing device, the biasing device applying a biasing force to one of the first and second members to thereby maintain sealing engagement of the one of the first and second members with the other of the first and second members.
4. The flow control apparatus according to claim 1, further comprising a locking mechanism, the locking mechanism selectively preventing displacement of the first member relative to the second member.

5. The flow control apparatus according to claim 4, wherein the locking mechanism is configured to selectively permit displacement of the first member relative to the second member upon application of fluid pressure to the locking mechanism.

6. The flow control apparatus according to claim 4, wherein the first member is sealingly engageable with the second member, and wherein the locking mechanism is configured to releasably prevent displacement of the first member relative to the second member when the first member is sealingly engaged with the second member.

7. The flow control apparatus according to claim 1, further comprising a generally tubular outer housing, the first and second members being disposed at least partially within the outer housing, and the outer housing being configured for cooperative attachment to a tubing string positioned within the subterranean well.

8. A choke operatively positionable within a subterranean well, the choke comprising:

- a generally tubular first member;
- a generally tubular second member slidingly disposed relative to the first member, the second member having at least one flow port formed through a sidewall portion thereof, and the second member further being variably positionable relative to the first member to variably regulate fluid flow through the flow port.

9. The choke according to claim 8, wherein the first member is sealingly engageable with the second member to prevent fluid flow through the flow port.

10. The choke according to claim 8, wherein the second member is secured to a mandrel, the mandrel being displaceable relative to the first member to thereby displace the second member relative to the first member.

11. The choke according to claim 10, wherein the mandrel is rotatably secured to the second member.

12. The choke according to claim 10, wherein the mandrel is configured for displacement relative to the first member by application of fluid pressure thereto.

13. The choke according to claim 10, wherein the mandrel has a shifting profile formed thereon, and wherein the profile is configured for engagement with a shifting tool.

14. The choke according to claim 8, further comprising a biasing device, the biasing device being configured to bias the second member toward sealing engagement with the first member.

15. The choke according to claim 8, wherein the second member is selectively and releasably securable relative to the first member.

16. The choke according to claim 15, wherein the second member is securable relative to the first member when the second member sealingly engages the first member to prevent fluid flow through the flow port.

17. The choke according to claim 8, wherein the first member is a sleeve, and wherein the second member is a cage.

18. Apparatus operatively positionable within a subterranean well, the apparatus comprising:

- a generally tubular member having a flow passage extending generally axially therethrough, and the member further having a first port formed through a sidewall portion thereof; and
- a sleeve slidingly disposed relative to the member, the member being positionable relative to the sleeve in a selected one of a first position in which the sleeve prevents fluid flow through the first port, a second position in which unobstructed fluid flow is permitted

17

through the first port, and a third position in which fluid flow through the first port is partially obstructed by the sleeve.

19. The apparatus according to claim 18, wherein the sleeve has a lip extending outwardly therefrom, the lip being disposed generally radially opposite the first port when the member is in the third position.

20. The apparatus according to claim 19, wherein the lip is configured to inhibit erosion of the sleeve when the member is in the third position.

21. The apparatus according to claim 19, wherein the lip is configured to inhibit erosion of the tubular member when the member is in the third position.

22. The apparatus according to claim 18, further comprising a first seal surface carried on the member, and a second seal surface formed on the sleeve, the first and second seal surfaces being sealingly engaged when the member is in the first position.

23. The apparatus according to claim 18, further comprising a generally tubular outer housing, the member and sleeve being disposed at least partially within the housing.

24. The apparatus according to claim 23, wherein the sleeve is coaxially attached within the housing.

25. The apparatus according to claim 24, wherein an end portion of the sleeve has a lip extending outwardly therefrom, and wherein the lip is positioned radially inward relative to an opening formed through a sidewall portion of the housing.

26. The apparatus according to claim 18, wherein the member further has a second port formed through the member sidewall portion, the first and second ports being axially spaced apart.

27. The apparatus according to claim 26, wherein in the first, second and third positions of the member, fluid flow is permitted through the second port.

28. The apparatus according to claim 27, wherein the member further has fourth and fifth positions relative to the sleeve, fluid flow being permitted through the second port when the member is in the fourth position, and fluid flow through the second port being prevented when the member is in the fifth position.

29. The apparatus according to claim 26, wherein the second port has a flow area unequal to a flow area of the first port.

30. The apparatus according to claim 18, wherein the tubular member further has a second port formed through the sidewall portion thereof, and wherein the second port is positioned opposite the first port, whereby when fluid flows inwardly through each of the first and second ports, the fluid flows interfere with each other and inhibit erosion of the tubular member.

31. The apparatus according to claim 18, wherein the member is further positionable in an infinite number of positions between the first and second positions.

32. The apparatus according to claim 18, wherein the sleeve is radially outwardly disposed about the member.

33. The apparatus according to claim 32, further comprising a generally tubular seat carried externally on the member, the seat sealingly engaging the sleeve when the member is in the first position.

34. A choke operatively positionable within a subterranean well and operatively connectable to an actuator disposed within the well, the actuator having an actuator member which is displaceable relative to the remainder of the actuator in a selected one of first and second opposite directions, the choke comprising:

a first member interconnectable to the actuator member and displaceable therewith;

18

a seal surface carried on the first member; and a second member slidably disposed relative to the first member,

the first member being displaceable in the first direction by the actuator member to sealingly engage the second member with the seal surface to thereby prevent fluid flow through a sidewall portion of the first member, and the first member being displaceable in the second direction by the actuator member to thereby permit fluid flow through the sidewall portion of the first member.

35. The choke according to claim 34, wherein the second member is a sleeve externally disposed about the first member.

36. The choke according to claim 34, further comprising a port formed through the sidewall portion, the port being positionable between the seal surface and the second member when the first member is displaced in the second direction.

37. The choke according to claim 36, wherein the first member is variably positionable relative to the second member so that fluid flow through the port is correspondingly variably restricted.

38. The choke according to claim 36, wherein the sleeve has a flow deflection lip formed thereon, and wherein the lip is positionable in an overlying relationship to the port.

39. A choke operatively positionable within a subterranean well, the choke comprising:

a generally tubular inner cage having a port formed through a sidewall portion thereof;

a seat carried externally on the cage spaced apart from the port; and

a sleeve externally slidably disposed on the cage.

40. The choke according to claim 39, wherein the sleeve has opposite ends, one of the sleeve opposite ends being configured for sealing engagement with the seat.

41. The choke according to claim 40, wherein the other of the sleeve opposite ends is sealingly received within an outer housing.

42. The choke according to claim 41, wherein the sleeve is rigidly attached to the housing, the one of the sleeve opposite ends being positioned radially opposite an opening formed through a sidewall portion of the housing.

43. The choke according to claim 39, wherein the seat and sidewall portion of the cage are formed of a material having an erosion resistance greater than that of the remainder of the cage.

44. A method of controlling fluid flow into a tubing string disposed within a subterranean well, the method comprising the steps of:

attaching an actuator to the tubing string;

operatively attaching a choke to the actuator, the choke being capable of regulating fluid flow through a sidewall portion thereof, the choke including a choke member set; and

actuating the actuator to variably open the choke member set and thereby variably choke fluid flow therethrough.

45. The method according to claim 44, wherein the step of actuating the actuator to open the choke member set further comprises displacing a first tubular member relative to a second tubular member.

46. The method according to claim 45, wherein the first tubular member displacing step comprises displacing a seat portion of the choke member set out of sealing engagement with a sleeve portion of the choke member set.

47. The method according to claim 46, wherein the first tubular member displacing step further comprises displacing

a port formed through the first tubular member relative to the choke member set sleeve portion.

48. The method according to claim 47, wherein the port displacing step comprises displacing the port from a first position in which the port is radially inwardly disposed relative to the sleeve portion, to a second position in which the port is at least partially open to fluid flow therethrough.

49. The method according to claim 47, wherein the port displacing step comprises displacing the port from a first position in which fluid flow through the port is prevented by sealing engagement of the sleeve portion with the seat portion, to a second position in which fluid flow through the port is partially obstructed by the sleeve portion.

50. A method of controlling fluid flow within a subterranean well, comprising the steps of:

providing an actuator having an actuator member which is displaceable relative to the remainder of the actuator in a selected one of first and second opposite directions;

providing a choke including a first member interconnectable to the actuator member and displaceable therewith, a seal surface carried on the first member, and a second member slidably disposed relative to the first member, the first member displacing relative to the second member and thereby permitting a progressively greater rate of fluid flow through a sidewall portion of the first member when the actuator member is displaced in the first direction, and the first member displacing relative to the second member and thereby increasingly restricting fluid flow through the sidewall portion when the actuator member is displaced in the second direction;

operatively interconnecting the actuator to the choke; and positioning the actuator and choke within the well.

51. The method according to claim 50, further comprising the step of displacing the actuator member in the second direction to sealingly engage the second member and the seal surface and thereby prevent fluid flow through the sidewall portion.

52. The method according to claim 50, wherein the choke is provided further including first and second ports formed through the sidewall portion.

53. The method according to claim 52, wherein the choke is provided with the first port having a restriction to fluid flow therethrough which is not equal to a restriction to fluid flow through the second port.

54. The method according to claim 50, further comprising the step of displacing the actuator member in the first direction, thereby telescopically extending the first member from within the second member.

55. A method of controlling fluid flow within a subterranean well, comprising the steps of:

providing a tubular member having a plurality of spaced apart ports formed therethrough;

providing a blocking member for blocking fluid flow through the plurality of ports;

positioning the tubular member and blocking member within the well; and

displacing the tubular member relative to the blocking member to thereby permit fluid flow through the plurality of ports.

56. The method according to claim 55, further comprising the step of providing a housing, the blocking member being disposed within, and attached to, the housing, and wherein the step of displacing the tubular member further comprises displacing the tubular member relative to the housing to thereby permit fluid flow through a sidewall portion of the housing.

57. The method according to claim 55, wherein the tubular member displacing step further comprises selecting a first one of the ports for fluid flow therethrough by displacing the tubular member in a first selected direction.

58. The method according to claim 57, wherein the tubular member displacing step further comprises selecting a second one of the ports for fluid flow therethrough, in addition to the first one of the ports, by further displacing the tubular member in the first selected direction.

* * * * *