

[72] Inventor **Nicomedes Borges**
 Caracas, Venezuela
 [21] Appl. No. **756,206**
 [22] Filed **Aug. 29, 1968**
 [45] Patented **Sept. 14, 1971**

FOREIGN PATENTS

1,239,266	7/1960	France	128/92 D
1,507,627	11/1967	France	128/92
867,422	7/1949	Germany	128/92 D
335,797	3/1959	Switzerland	128/92 D

[54] **BONE SETTING DEVICE**
 1 Claim, 6 Drawing Figs.

[52] U.S. Cl. 128/92 D
 [51] Int. Cl. A61f 5/04
 [50] Field of Search..... 128/83, 92,
 92 A, 92 D, 92 E, 87, 92 R, 92 ED, 87 R

Primary Examiner—Richard A. Gaudet
Assistant Examiner—J. B. Mitchell
Attorneys—Clarence A. O'Brien and Harvey B. Jacobson

[56] **References Cited**
UNITED STATES PATENTS
 2,406,832 9/1946 Hardinge..... 128/92 D
 2,434,431 1/1948 Pincock..... 128/92 A
 3,244,170 4/1966 McElvanny 128/92
 1,025,008 4/1912 Miner..... 128/92 D

ABSTRACT: An osteosynthesis plate of two-piece construction having a toothed rack system to enable sliding movement of the two pieces in a direction to move the plate pieces in a direction to achieve the greatest approximation of a fractured bone to facilitate joining the fracture in the bone. The plates are secured to the fragments of the bone by screw members and a tool for moving the plates toward each other is provided to facilitate engagement with the plates after they have been attached to the fragments of the fractured bone.

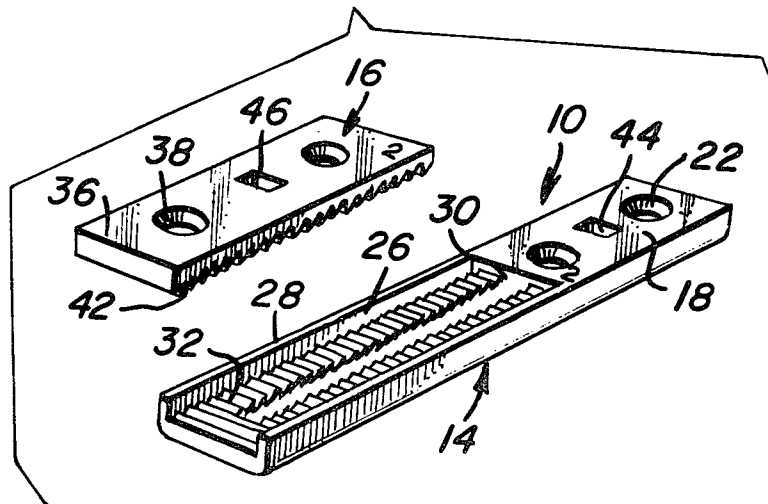

Fig. 1

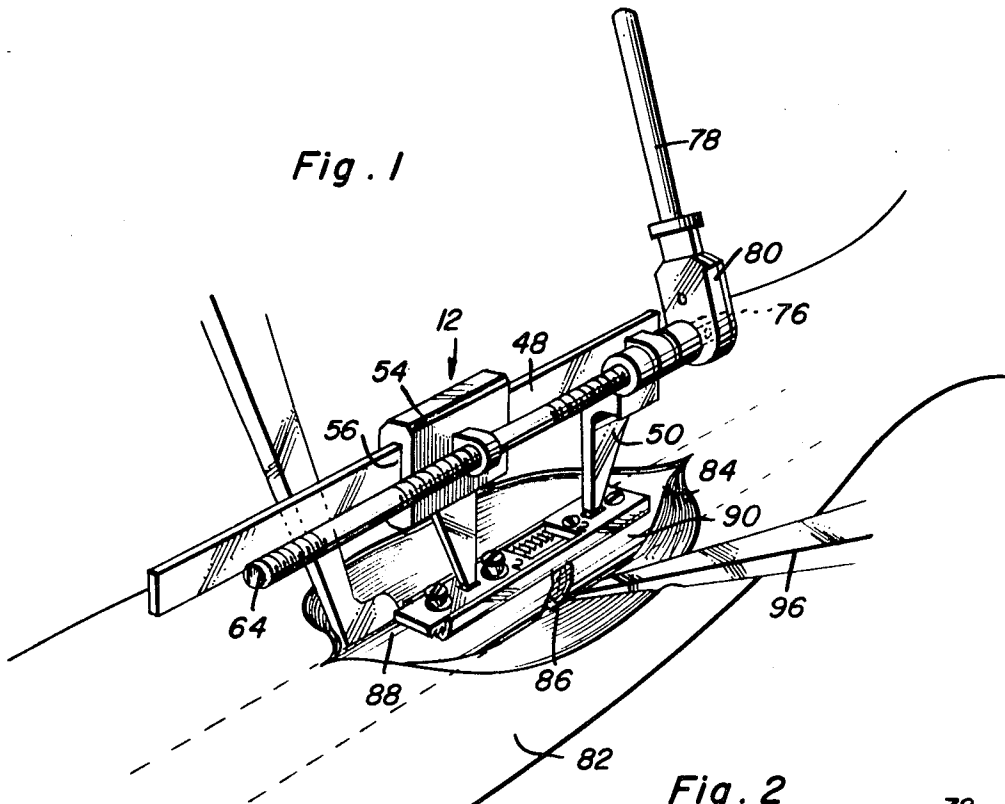
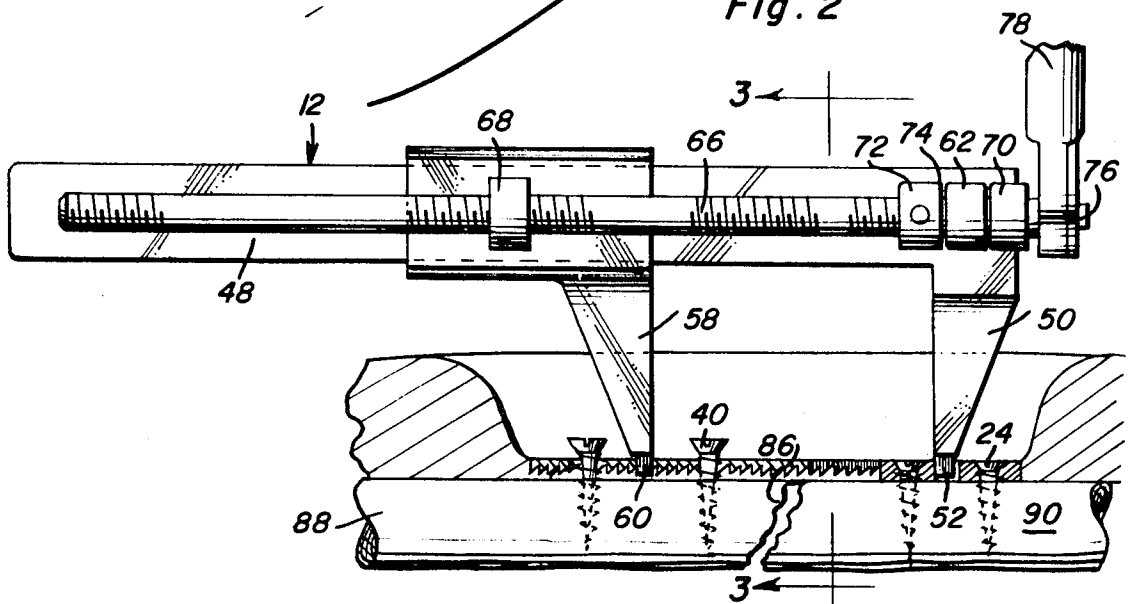

Fig. 2



Nicomedes Borges (Rivas)
INVENTOR.

BY *Oliver A. O'Brien*
and Harvey B. Jacobson
Attorneys

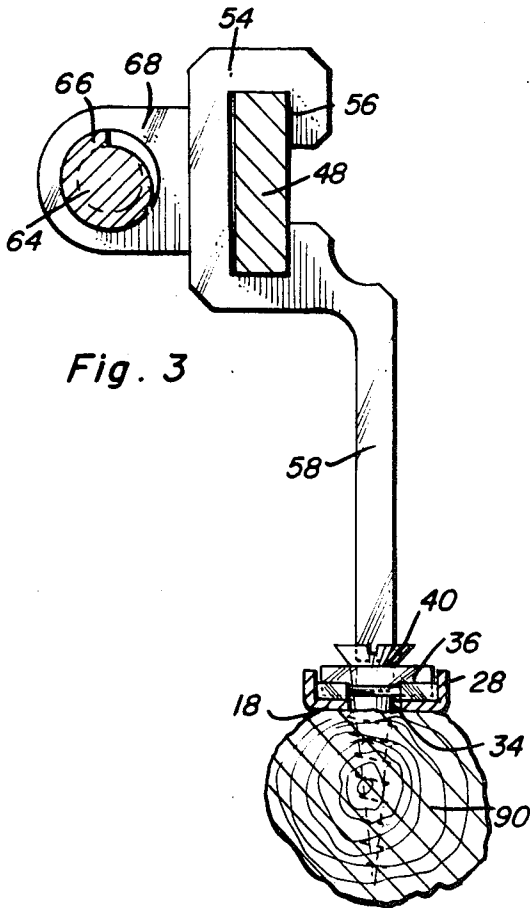

Fig. 3

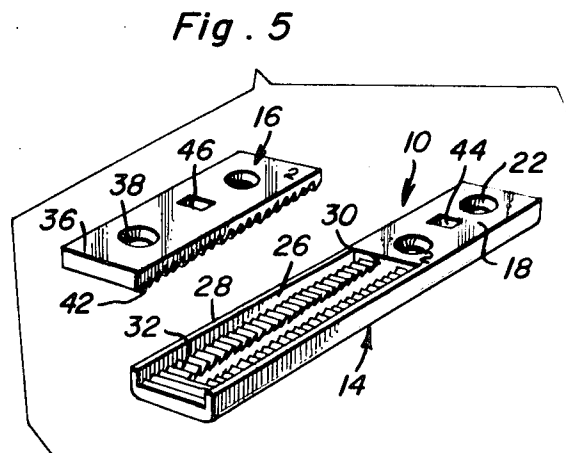

Fig. 5

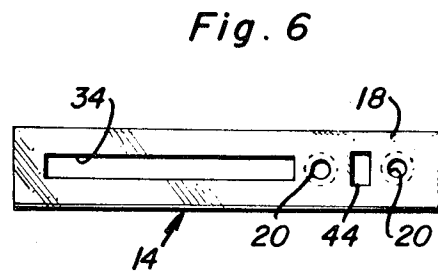

Fig. 6

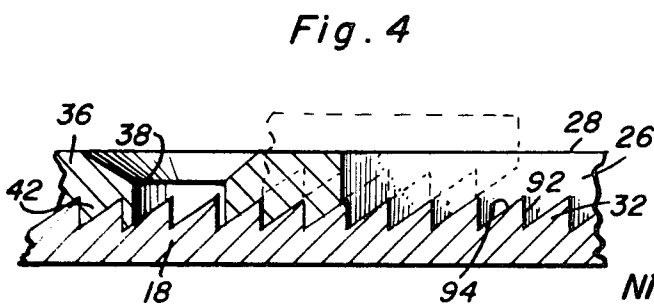

Fig. 4

Nicomedes Borges (Rivas)

INVENTOR.

BY *Alfonso A. O'Brien*
and Harvey B. Jacobson
Attorneys

BONE SETTING DEVICE

The present invention generally relates to the field of medicine and more particularly to traumatological surgery.

At the present time, osteosynthesis, the repair of fractures by use of extraneous material such as a metal plate, so-called osteosynthesis plates have been used which is in the form of a strip of material of stainless steel or vitallium, which are accepted by the body with the least degree of reaction, are attached by apposition to the fractured bone. Various types or models of such plates have been employed but all of them operate under a single principle, that is, maintaining the fragments of a fractured bone in the closest position to their normal state so they can unite by the formation of a bony callus due the proximity of the fragments. However, this consolidation of the bone is impeded in a great number of cases by the fact that the more the fragments are separated and mobile, the consolidation is retarded and the formation of pseudoarthrosis is stimulated which defect renders the bone incompatible with its normal functioning.

In view of each undesirable results caused by the single-piece construction of the osteosynthesis plate, the present plate constructed of two pieces enables one piece to be moved in relation to the other by employing interengaging teeth between the two sections or pieces of the plate. Each piece of the plate is located on one of the bone fragments and attached thereto by screws which permit sliding in the direction of approximation, but not in the direction of separation due to the particular configuration of the toothed connection therebetween.

An instrument is provided for sliding the two pieces of the osteosynthesis plate in an approximation direction which includes a pair of parallel arms engaged with a rodlike member having opposite screw threads thereon for moving the arms toward and away from each other. The outer ends of the arms and each piece of the plate have correspondingly shaped projections and orifices receiving the projections to enable movement of the pieces of the plate in an approximation direction.

One of the objects of the present invention is to provide an osteosynthesis plate and an instrument for moving the two pieces thereof in an approximation direction which is effective for the purpose of consolidating the fragments of a fractured bone, relatively easy to use while being dependable and long lasting.

These together with other objects and advantages which will become more subsequently apparent reside in the details of construction and operation as more fully hereinafter described and claimed, reference being had to the accompanying drawings forming a part hereof, wherein like numerals refer to like parts throughout, and in which:

FIG. 1 is a perspective view illustrating the osteosynthesis plate and the instrument for moving the two pieces thereof towards approximation illustrating the manner of use thereof;

FIG. 2 is a side elevational view of the assembly of FIG. 1 with the osteosynthesis plate in section;

FIG. 3 is a transverse, sectional view taken substantially upon a plane passing along section line 3—3, on an enlarged scale, of FIG. 2 illustrating further structural details of the invention;

FIG. 4 is an enlarged fragmental sectional view of the two pieces of the plate illustrating the relationship of the toothed interconnection therebetween;

FIG. 5 is an exploded group perspective view of the two-piece osteosynthesis plate; and

FIG. 6 is a bottom plan view of one piece of the plate.

Referring now specifically to the drawings, the osteosynthesis plate is generally designated by the numeral 10 and the clamp or instrument for manipulating the two pieces of the plate is designated by the reference numeral 12. The plate 10 includes two pieces, segments or sections generally designated by the numerals 14 and 16 respectively with the segment 14 including an elongated relatively narrow and thin rectangular body 18 having a pair of longitudinally spaced and aligned

apertures 20 extending therethrough with the upper ends of each aperture 20 being countersunk at 22 for receiving screw-type fasteners 24 as illustrated in FIG. 2. Provided in the upper surface of the body 18 is an elongated recess 26 extending from a point adjacent the inner orifice 20 to the opposite end thereof with the recess 26 being defined by a pair of edge flanges 28 and an inner end surface 30. The bottom of the recess 26 is provided with a plurality of transversely extending teeth 32 thereon and an elongated slot 34 extends substantially throughout the length of the bottom of the recess 26.

The piece or segment 16 includes an elongated rectangular body 36 adapted to be received within the recess 26 between the flanges 28 with the body 36 having a pair of countersunk apertures 38 extending therethrough for receiving the screw-threaded fasteners 40 as illustrated in FIG. 1. The lower surface of the body 36 is provided with a plurality of transversely extending teeth 42 thereon for interengagement with the teeth 32 within the recess 26. When the section 16 is assembled with the section 14, the teeth 42 and 32 are interengaged and the screw-threaded fasteners 40 extending through the apertures 38 also extend through the slot 34 in the section 14. Centrally of the section 14 intermediate the apertures 20, a square recess or opening 44 extends therethrough and a similar square or rectangular opening 46 extends through the section 16 between the two apertures 38.

The instrument 12 for manipulating the segments 14 and 16 of the osteosynthesis plate 10 includes a bar of elongated rectangular configuration with the transverse cross section of the bar also being rectangular. At one end of the bar 48, there is provided a laterally extending arm 50 of one-piece construction with the bar 48, with the outer end of the arm 50 including a projection 52 for reception within the opening 44 in the section 14 of the plate 10.

Slidable on the bar 48 is a sleeve 54 having a recess 56 extending therethrough closely receiving the bar 48 for sliding movement thereon. The sleeve 54 is provided with an arm 58 of one-piece construction therewith which is disposed in parallel coplanar relation with the arm 50 and terminates in a projection 60 at its free end for engagement in the opening 46 in the plate segment 16. The projections 52 and 60 are of a shape and configuration to closely fit within the openings 44 and 46 respectively so that when the arm 58 is moved toward the arm 50, the plate segment 16 will be moved toward the plate segments 14.

The end of the bar 48 having the arm 50 thereon is also provided with a laterally projecting sleeve or bearing block 62 journaling an elongated rod 64 therein. The rod 64 has the major portion thereof externally threaded at 66 for threaded engagement with a laterally extending internally threaded sleeve or boss 68 formed unitarily with the sleeve 64 in alignment with the bearing block 62. Fixedly mounted on the rod 64 is a pair of abutment members 70 and 72 which are disposed on opposite sides of the bearing block 62 and engage the bearing block 62 with washers 74 therebetween if desired so that when the rod 64 is rotated, the members 70 and 72 will prevent axial movement thereof thereby causing the boss 68 and the sleeve 54 as well as the arm 58 to move longitudinally on the bar 48 when the rod 64 is rotated.

The end of the rod 64 which extends beyond the sleeve or abutment member 70 is formed with a polygonal end 76 for the reception of a suitable wrench or handle 78 which includes a ratchet mechanism within a housing 80 so that the handle 78 may be ratcheted to cause rotation of the threaded rod 64 in a selected rotational direction.

In utilizing the invention, the fracture site such as in the forearm 82 is opened surgically as at 84 in the usual manner to expose the fracture 86 between fragments or segments 88 and 90 of the bone. Once the fracture has been reduced, section 14 is placed on the end of one of the fragments such as fragment 90 of the bone and is temporarily held in place by a bone clamp while it is attached to the bone fragment with two screws 24 as illustrated in FIG. 2 so that the end thereof having the slot 34 therein extends beyond the fracture 86 into

overlying relation to the bone fragment 88. Piece or segment 16 is then put in place within the recess 26 with the screws 40 being inserted through the apertures 38 and the slot 34 but not tightened completely to enable sliding movement of the segment 16 in a direction to bring the bone fragments 88 and 90 into contacting engagement with each other or into close approximation. As soon as the piece 16 has been attached in the manner illustrated, movement in a direction to increase the distance between the ends of the bone fragments 88 and 90 is precluded by the teeth 32 and 42. This is assured inasmuch as all of the teeth 32 on the segment 18 have a surface 92 in perpendicular relation to the longitudinal axis of the segment 18 and facing the end surface 30 of the recess 26 with the apex of each tooth defining the upper limit of the vertical surface 92 and the upper limit of an inclined surface 94 thus defining a tooth which will enable movement of the plate 36 in a direction toward the apertures 20 and preclude movement in the opposite direction. As illustrated in FIG. 4, the teeth 42 in the segment 16 are oppositely oriented so that the teeth 32 and 42, in effect form a one-way ratcheting engagement between the segments of the plate. In this condition such as illustrated in FIGS. 1 and 2, the instrument or tool 12 is applied and by operating the ratchet handle 48, the fracture 86 may be substantially closed by bringing the ends of the bone fragments 88 and 90 into contact with each other or into substantially approximation of each other to facilitate the consolidation or uniting thereof. During this procedure, the surgical incision 84 may be kept open by employing conventional instruments 96 for this purpose and conventional bone clamps may be employed for alignment of the bone fragments and bringing the bone fragments 88 and 90 into closer approximation before installation of the osteosynthesis plate. After installation of the plate and operation of the instrument 12 to position the bone fragments 88 and 90 in the optimum position, the screws 40 are tightened into a final condition thus securing the plate in position after which the surgical incision 84 is closed in the usual manner.

The osteosynthesis plate will be provided in different lengths and sizes with suitable indicia provided for indicating the size. The indicia may be in the form of matching numerals on the upper surface of the segments 14 and 16 respectively. The plate and the clamp may be readily rendered aseptic and are constructed of conventional materials employed for surgical instruments and the number, shape and size of teeth may

be varied to vary the increments of movement of the segments of the plate in relation to each other in order to enable accurate and positive approximation of the end of the bone fragments defining the line of fracture to facilitate the consolidation or knitting of the surfaces defining the fracture.

The foregoing is considered as illustrative only of the principles of the invention. Further since numerous modifications and changes will readily occur to those skilled in the art, it is not desired to limit the invention to the exact construction and operation shown and described, and accordingly all suitable modifications and equivalents may be resorted to, falling within the scope of the invention as claimed.

What is claimed as new is as follows:

1. A device for setting bone fragments comprising an osteosynthesis plate constructed of first and second substantially flat elongated pieces, said first piece having upper and lower surfaces and first and second ends, the lower surface being adapted to engage the bone fragments, said second piece overlying the upper surface of said first piece and being adapted to remain remote from the bone fragments, means for guiding said pieces and enabling longitudinal movement of the pieces toward each other into approximation but preventing movement in the opposite direction after approximation has been achieved, said means including a longitudinal recess in said first piece extending over a major portion of the length thereof and defining flanges slidably receiving substantially the entire length of said second piece, said means further including a plurality of teeth in said longitudinal recess and a plurality of teeth on said second piece, said teeth on said first piece having two faces, one of said two faces being substantially perpendicular to the longitudinal axis of said first piece and the other of said faces being inclined toward said first end, said teeth on said second piece also having a pair of faces, one of said pair of faces being substantially perpendicular to the longitudinal axis of said second piece and the other of said pair of faces being inclined toward said second end, each of said pieces of said plate including at least one aperture therein, said recess including a longitudinal slot therein underlying said aperture in said second piece, a fastener extending through each of said apertures and adapted to engage the bone fragments, an opening in each of said pieces, and means for engaging the openings and moving the two pieces of the plate into approximation.

45
50
55
60
65
70
75