

(12) **UK Patent Application** (19) **GB** (11) **2 231 322 A** (13)

(43) Date of A publication 14.11.1990

(21) Application No 9010513.1

(22) Date of filing 10.05.1990

(30) Priority data
(31) 1523 (32) 10.05.1989 (33) IE

(71) Applicant
Neil Bass
Eyerles, Bantry, County Cork, Ireland

(72) Inventor
Neil Bass

(74) Agent and/or Address for Service
Marks & Clerk
57-60 Lincoln's Inn Fields, London, WC2A 3LS,
United Kingdom

(51) INT CL⁵
B65D 81/34 81/20

(52) UK CL (Edition K)
B8K KAD K2K7 K2X3
B8C CBE3
B8P PE2X
U1S S1081 S1291

(56) Documents cited
GB 2181399 A US 4452356 A US 3978260 A
US 3835995 A US 3503493 A

(58) Field of search
UK CL (Edition K) **B8C CBE3, B8K KAA KAD, B8P**
PK10
INT CL⁵ **B65D**
Online databases: **WPI**

(54) **A packaging structure**

(57) A substantially rigid packaging support has a central support body 5 of expanded foam polystyrene, and an upper card 6 and a lower card 7 both of food grade material adhesively bonded to the front and rear faces of the support body 5. The body 5 and the cards 6, 7 are covered by an outer polyethylene film 10 on which food such as a side or fillet of smoked or marinated salmon or trout 2 is placed and then packed in a vacuum bag 3. At least the exposed surfaces of the cards 6, 7 are printed with indica, decorations or the like. Alternatively the packaging support comprising the body 5 and printed cards 6, 7 may form part of at least one side wall of a mailing box 20.

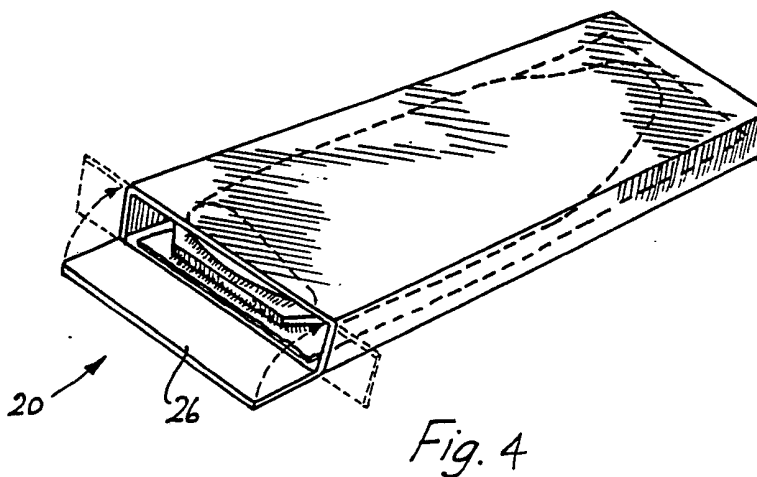
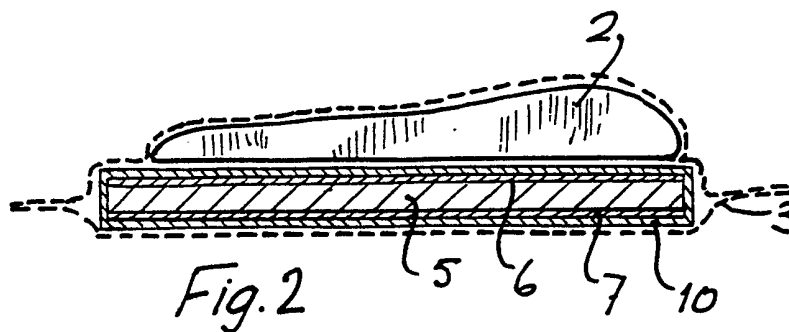

GB 2 231 322 A

1/2

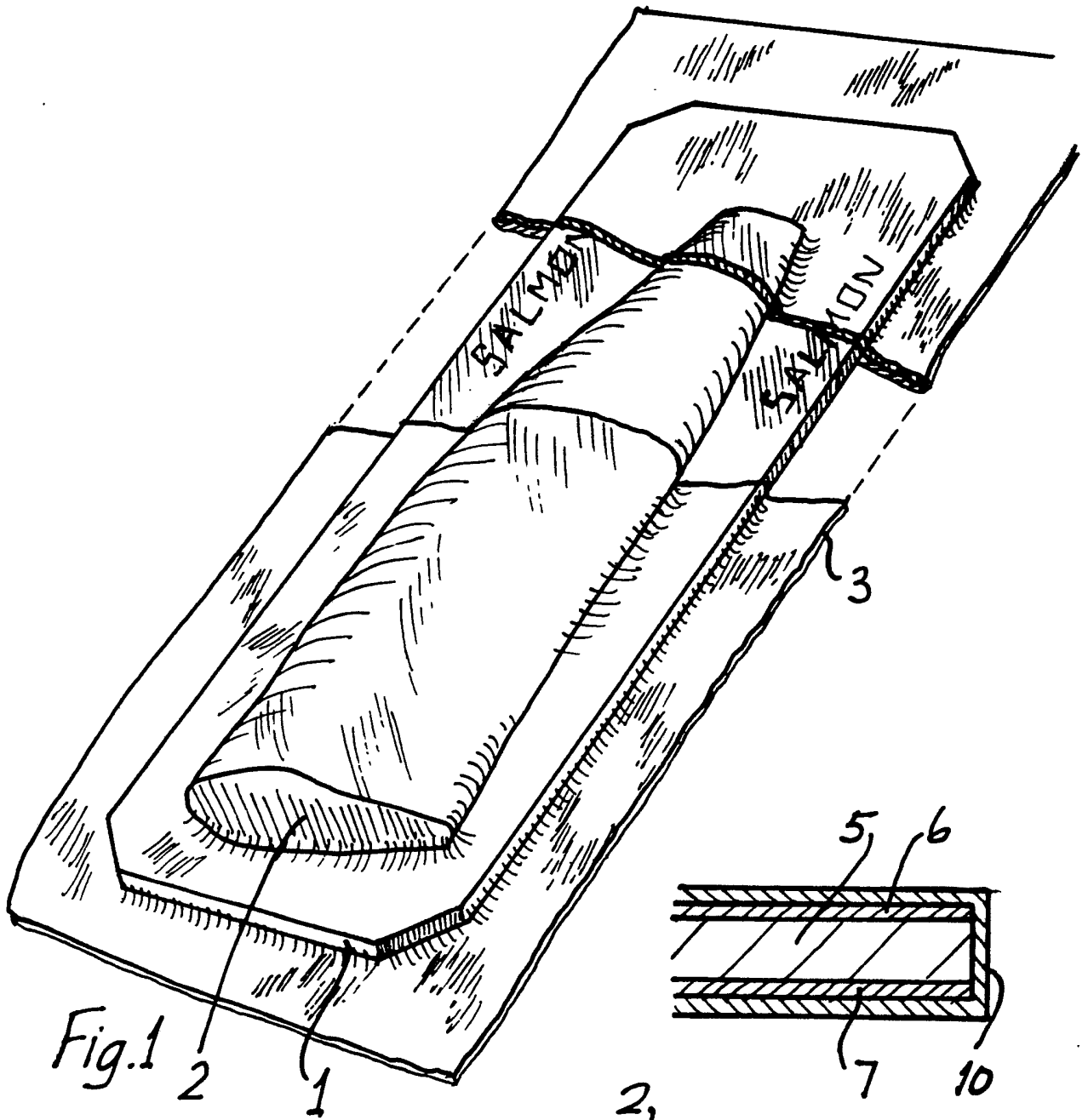

Fig. 1

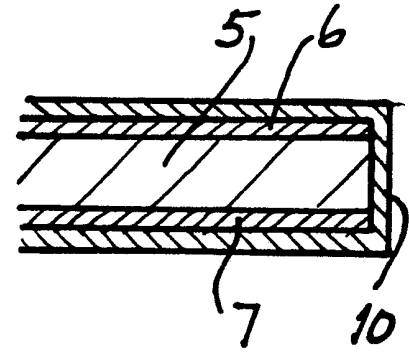

Fig. 3

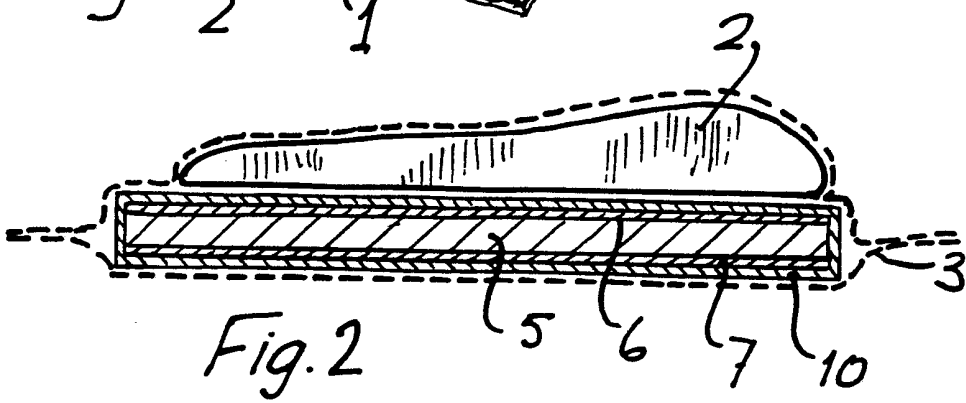
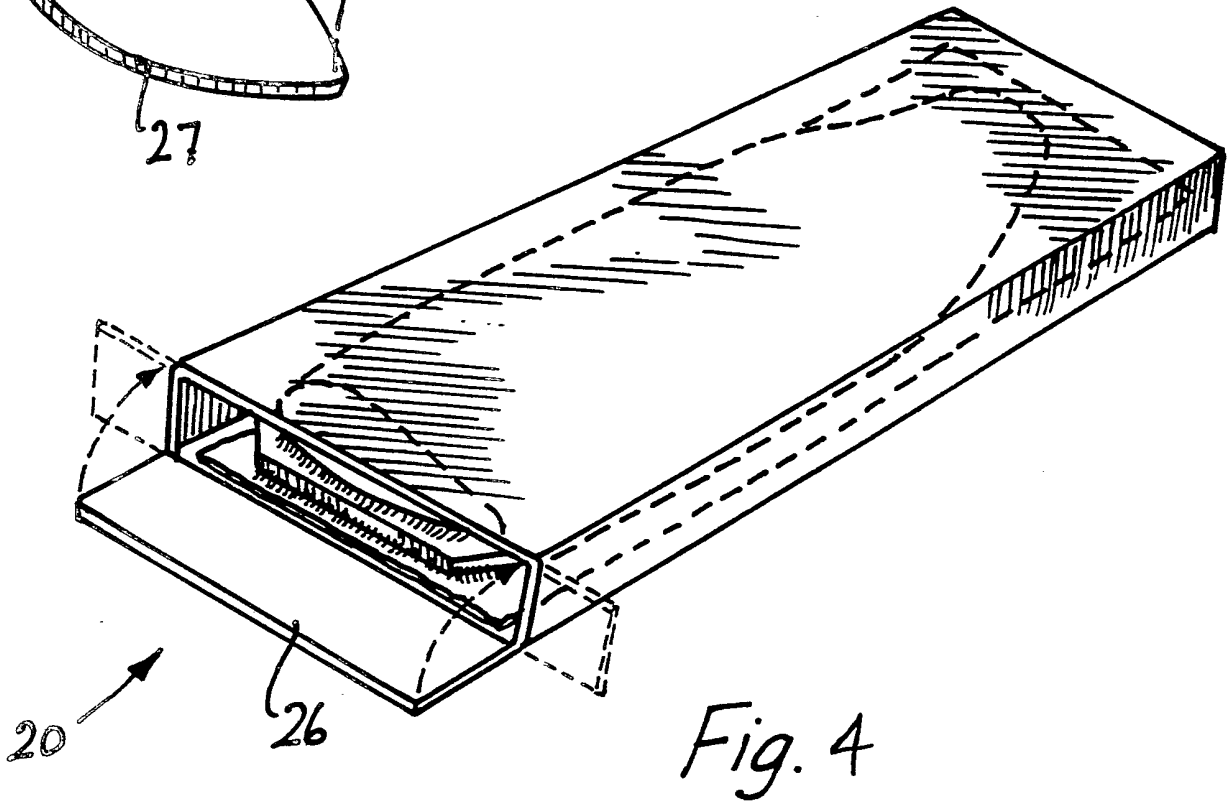
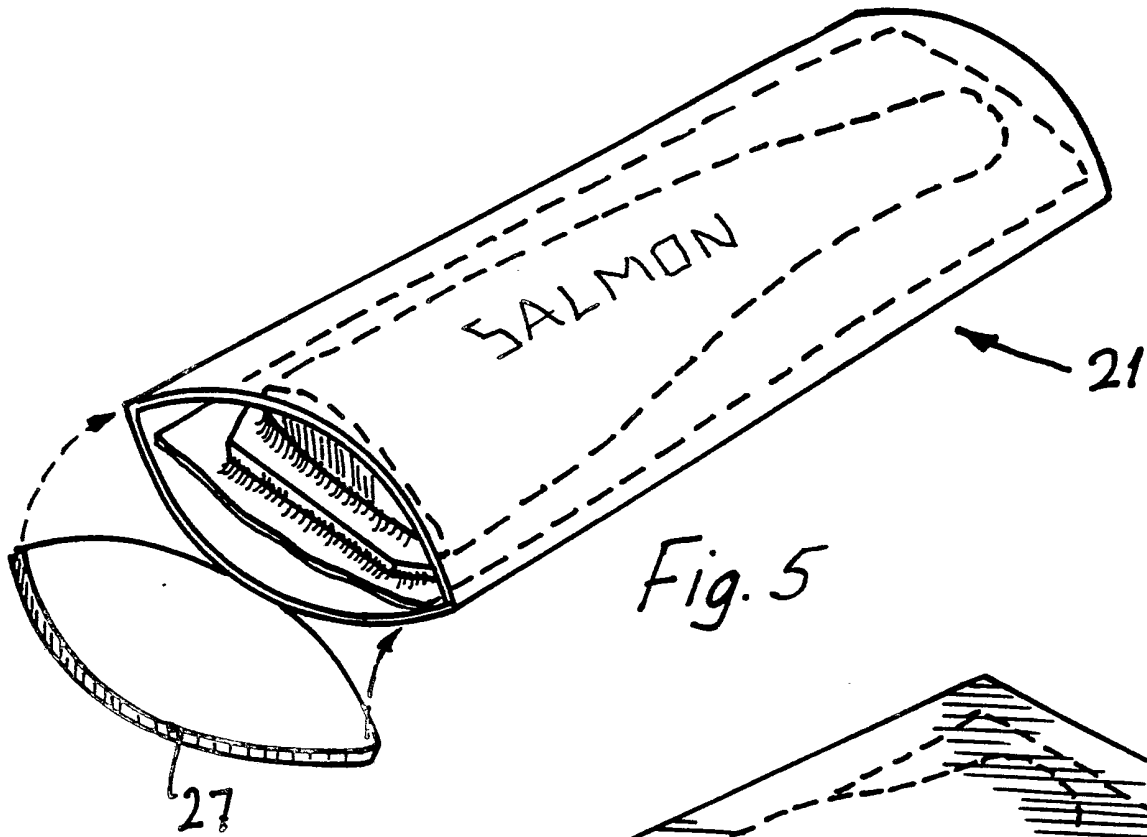

Fig. 2



"A PACKAGING STRUCTURE"

The invention relates to a packaging support for use for packaging food products, particularly but not exclusively for packaging fish.

In particular the invention relates to a packaging structure
5 for use in packaging smoked or marinated sides or fillets of salmon, trout, or other fish.

At present, sides of salmon or trout are generally packaged for preservation and presentation inside a vacuum packed bag. Frequently the side of fish is placed onto a backing board
10 prior to vacuum packaging. Such backing boards generally comprise a flat rectangular sheet of food grade card which is typically between 500 and 1500 microns in thickness and which fills the interior of the vacuum pouch. This card may be any one of the following three types:

- 15 a. laminated on one or both sides with a thin foil (which is either gold or silver in colour);
- b. the food grade card having indicia printed thereon, the product being protected from the ink and the

card waterproofed by the application of a polyethylene film around the card; or

- 5 c. a backing board comprising a cut or moulded sheet of polystyrene on which the fish is either laid directly or onto which a lightweight food grade card is laid onto which the fish is placed;

All of these packaging structures suffer from considerable disadvantages as they provide a packed product which is not generally aesthetically pleasing and consequently does not
10 have customer appeal.

The construction of backing board in all known arrangements is also relatively weak. Picking up the side of the packaged fish by the end of the board or in one hand can cause the product to bend or otherwise deform. Potential damage to the
15 contained product is considerable since deformation of the board can cause deformation of the product and rupturing of the package. Given the perceived quality and price of the products generally contained in such packages the packaging is of generally poor appearance and quality. This is both
20 because of the weak structure and poor decorative appearance and coordination of the components of the package.

This invention is directed towards providing an improved packaging support for food products to overcome at least some of these difficulties.

According to the invention there is provided a substantially rigid packaging support for a food product comprising:

an elongate central support body; and

5 a food grade card attached to the support body, the card having indica printed on the outwardly facing surface thereof.

In a prepared embodiment of the invention the exposed surfaces of the support body and card are encased by an outer transparent lamina.

10 Preferably there are two cards, one attached to each longitudinal face of the support body.

In one embodiment of the invention the food grade card is constructed to have a grain extending longitudinally to strengthen the support in the longitudinal direction.

15 Preferably the food grade card is adhesively bonded to the central support body.

In a prepared embodiment of the invention the central support body is of expanded foam, preferably polystyrene material.

Preferably the outer lamina is of plastics film, preferably polyethylene material.

The invention also provides a method of producing a packaging support of the invention, the method comprising the steps of
5 laying down a sheet of food grade card with the printed side lowermost, applying an adhesive to the back of the card, and laying the central support body down on the card to bond the support body to the card.

In another aspect of the invention provides a box having
10 sidewalls, any or all of which comprise a packaging support according to the invention.

The invention further provides a packaged food product comprising a packaging support of the invention, a food product such as a side of fish, mounted on the support and an
15 outer transparent packaging provided around the food product and the support.

Preferably in this case the outer packaging is a vacuum packaged bag or the like.

The invention will be more clearly understood from the
20 following description thereof given by way of example only with reference to the accompanying drawings in which:

Fig. 1 is a diagrammatic perspective view of a packaging support according to the invention, in use,

Fig. 2 is a diagrammatic cross sectional view of the packaging support of Fig. 1,

5 Fig. 3 is an enlarged cross sectional view of part of the packaging support,

Fig. 4 is a perspective view of a mailing box according to the invention, and

10 Fig. 5 is a perspective view of another mailing box according to the invention.

Referring to the drawings and initially to Figs. 1 to 3 thereof there is illustrated a substantially rigid packaging support according to the invention indicated generally by the reference numeral 1 which is illustrated in this case for use
15 in packaging a side or fillet of smoked or marinated salmon or trout 2 in a vacuum packed bag 3.

The packaging support 1 is in this case a sandwich structure having a central support body 5 of expanded polystyrene material, an upper card 6 of food grade material and a lower
20 card 7 also of food grade card material. In this case the

cards 6, 7 are adhesively bonded to the front and rear faces of the support body 5. The support body 5 and cards 6, 7 are covered in this case by an outer lamina comprising a film 10 of a material which is both waterproof and food grade such as polyethylene plastics film material. A fillet of fish 2 to be packaged is placed on the upper face of the card 6 and is then vacuum packed in a vacuum bag 3 in a conventional manner.

At least the exposed surface of the upper card 6 and preferably also the lower card 7 are printed with indicia, decorations, trade marks or the like to provide an aesthetically pleasing and marketable packaged product. The cards 6, 7 are preferably constructed so that the grain of the cards extend longitudinally for added structural support in the packaging.

It will be appreciated and in some cases an outer lamina film 10 may not be essential. In cases where it is provided it may be provided on only the upper food supporting face of the packaging structure.

It will also be appreciated that the cards may extend completely around the support body 5 to form a box-like support structure.

Referring to Figs. 4 and 5 there are illustrated two alternative constructions of mailing box 20, 21 respectively

formed using the packaging structure 1 described above with reference to Figs. 1 and 2. Sides or fillets of fish 2 are placed in the package for mailing. The package may be of any suitable shape and configuration and is shown in both cases
5 with particular arrangements of closure flaps 26, 27, however, it will be appreciated that any suitable arrangement for opening and closing the box may be provided. In both cases, preferably the food grade cards 6,7 are printed on their outside surface to provide a box having consumer appeal. In
10 both cases the printed design is coordinated on the backing board with the design of the exterior box surface. The presence of polystyrene or similar material in the structure lends strength, protection and insulation to the overall package for added structural strength.

15 Many variations on the specific embodiments of the invention described will be readily apparent and accordingly the invention is not limited to the embodiments hereinbefore described which may be varied in both construction and detail.

CLAIMS

1. A substantially rigid packaging support for a food product comprising:

an elongate central support body; and

a food grade card attached to the support body, the card having indica printed on the outwardly facing surface thereof.

2. A packaging support as claimed in claim 1 wherein the exposed surfaces of the support body and card are encased by an outer transparent lamina.
3. A packaging support as claimed in claim 1 or 2 wherein there are two cards, one attached to each longitudinal face of the support body.
4. A packaging support as claimed in any of claims 1 to 3 wherein the food grade card is constructed to have a grain extending longitudinally to strengthen the support in the longitudinal direction.

5. A packaging support as claimed in any preceding claim wherein the food grade card is adhesively bonded to the central support body.
6. A packaging support as claimed in any preceding claim wherein the central support body is of expanded foam material.
7. A packaging support as claimed in claim 6 wherein the central support body is of polystyrene material.
8. A packaging support as claimed in any of claims 2 to 7 wherein the outer lamina is of a plastics film material.
9. A packaging support as claimed in claim 8 wherein the lamina is of a polyethylene film material.
10. A packaging support substantially as hereinbefore described with reference to Figs. 1 to 3 of the accompanying drawings.
11. A method of producing a packaging support as claimed in any preceding claim comprising the steps of laying down a sheet of food grade card with the printed side lowermost, applying an adhesive to the back of the card, and laying the central support body down on the card to bond the support body to the card.

12. A packaging support whenever produced by the method of claim 11.
13. A box having sidewalls, any or all of the sidewalls comprising a packaging support as claimed in any of claims 1 to 10.
14. A box as claimed in claim 13 substantially as hereinbefore described with reference to Figs 3 to 4 of the accompanying drawings.
15. A packaged food product comprising a packaging support as claimed in any of claims 1 to 10, a food product mounted on the support and an outer transparent packaging provided around the food product and the support.
16. A packaged food product as claimed in claim 15 wherein the outer packaging is a vacuum packaged bag or the like.
17. A packaged food product as claimed in claims 15 or 16 wherein the food product is fish such as a side of smoked or marinated salmon, trout or the like.