



US007822139B2

(12) **United States Patent**
Simon

(10) **Patent No.:** **US 7,822,139 B2**
(45) **Date of Patent:** **Oct. 26, 2010**

(54) **APPARATUS, SYSTEMS, METHODS AND COMPUTER PRODUCTS FOR PROVIDING A VIRTUAL ENHANCED TRAINING SEQUENCE**

(75) Inventor: **Michael Simon**, Frederick, MD (US)

(73) Assignee: **Rohde & Schwarz GmbH & Co. KG**, Munich (DE)

(*) Notice: Subject to any disclaimer, the term of this patent is extended or adjusted under 35 U.S.C. 154(b) by 1112 days.

(21) Appl. No.: **11/420,384**

(22) Filed: **May 25, 2006**

(65) **Prior Publication Data**

US 2006/0244865 A1 Nov. 2, 2006

Related U.S. Application Data

(63) Continuation-in-part of application No. 11/276,434, filed on Feb. 28, 2006, now Pat. No. 7,738,582, and a continuation-in-part of application No. 11/276,453, filed on Feb. 28, 2006, now Pat. No. 7,532,677.

(60) Provisional application No. 60/684,407, filed on May 25, 2005, provisional application No. 60/657,416, filed on Mar. 2, 2005, provisional application No. 60/740,424, filed on Nov. 29, 2005.

(51) **Int. Cl.**
H04L 5/12 (2006.01)

(52) **U.S. Cl.** **375/265**

(58) **Field of Classification Search** **375/354, 375/256, 259-261, 265, 229-231; 714/699, 714/746, 786, 792, 752, 775, 776, 789; 455/3.01, 455/3.02; 370/464, 498, 503, 505**

See application file for complete search history.

(56) **References Cited**

U.S. PATENT DOCUMENTS

5,216,503 A	6/1993	Paik et al.	
5,614,914 A	3/1997	Bolgiano et al.	342/364
5,903,574 A	5/1999	Lyons	
6,005,605 A	12/1999	Kostreski et al.	
6,088,337 A	7/2000	Eastmond et al.	370/280
6,130,898 A	10/2000	Kosteski et al.	370/522
6,192,070 B1	2/2001	Poon et al.	375/222

(Continued)

FOREIGN PATENT DOCUMENTS

DE 196 17 293 11/1997

(Continued)

OTHER PUBLICATIONS

Battisa, "Spectrally Efficient High Data Rate Waveforms For The UFO SATCOM Channel", Military Communications Conference, Oct. 1998, Proceedings, IEEE vol. 1, 18-21, pp. 134-139.

(Continued)

Primary Examiner—David C Payne

Assistant Examiner—Vineeta S Panwalkar

(74) *Attorney, Agent, or Firm*—Fitzpatrick, Cella, Harper & Scinto

(57) **ABSTRACT**

A system, method, apparatus and computer code for communicating a training sequence for initializing an equalizer in a digital receiver are provided including receiving a digital signal containing data to be broadcast from a digital RF transmitter and inserting the training sequence into the digital signal deterministically such that a predetermined sequence of symbols are communicated to the receiver.

44 Claims, 15 Drawing Sheets

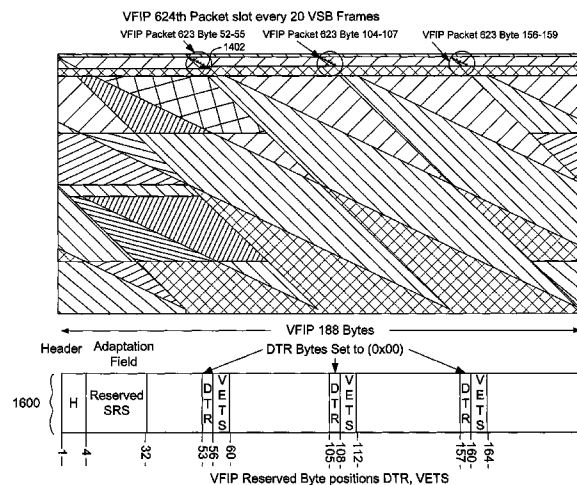

U.S. PATENT DOCUMENTS

6,269,092	B1	7/2001	Schilling	
6,313,885	B1	11/2001	Patel et al.	348/725
6,324,186	B1	11/2001	Mahn	370/503
6,414,720	B1	7/2002	Tsukidate et al.	348/469
6,477,180	B1	11/2002	Aggarwal et al.	370/468
6,480,236	B1	11/2002	Limberg	348/555
6,496,477	B1	12/2002	Perkins et al.	370/228
6,631,491	B1	10/2003	Shibutani et al.	
6,640,239	B1	10/2003	Gidwani	709/203
6,721,337	B1	4/2004	Kroeger et al.	370/477
6,772,434	B1	8/2004	Godwin	
6,801,499	B1	10/2004	Anandakumar et al.	370/229
6,804,223	B2	10/2004	Hoffmann et al.	370/342
6,930,983	B2	8/2005	Perkins et al.	370/252
7,110,048	B2	9/2006	Weiss	348/723
7,111,221	B2	9/2006	Birru et al.	714/755
7,336,646	B2	2/2008	Muller	
7,349,675	B2	3/2008	Karr et al.	455/102
7,382,838	B2	6/2008	Peting	375/327
7,539,247	B2	5/2009	Choi et al.	375/240.12
7,564,905	B2	7/2009	Park et al.	
7,599,348	B2	10/2009	Kang et al.	370/350
7,667,780	B2	2/2010	Weiss	348/723
2001/0033341	A1*	10/2001	Limberg	348/614
2002/0001349	A1	1/2002	Bretl et al.	
2002/0085548	A1	7/2002	Ku et al.	370/386
2002/0097336	A1	7/2002	Oshima	348/487
2002/0140867	A1	10/2002	Weiss	
2003/0099303	A1	5/2003	Birru et al.	
2003/0201932	A1	10/2003	Rabinowitz et al.	
2004/0013133	A1	1/2004	Fimoff et al.	370/473
2004/0062283	A1	4/2004	Takeuchi et al.	
2004/0066736	A1	4/2004	Kroeger	370/200
2004/0160344	A1	8/2004	Bretl et al.	
2004/0190779	A1*	9/2004	Sarachik et al.	382/199
2004/0237024	A1	11/2004	Limberg	714/784
2004/0240460	A1	12/2004	Hwang et al.	370/412
2005/0013249	A1	1/2005	Kong et al.	370/235
2005/0074074	A1	4/2005	Limberg	
2005/0162886	A1*	7/2005	Jeong et al.	365/63
2005/0207416	A1	9/2005	Rajkotia	370/390
2005/0249300	A1	11/2005	Jeong et al.	375/265
2005/0249301	A1	11/2005	Jeong et al.	375/265
2005/0259643	A1	11/2005	Chuah et al.	370/389
2006/0050770	A1	3/2006	Wallace et al.	375/144
2006/0200853	A1	9/2006	Simon	725/118
2006/0245516	A1	11/2006	Simon	375/295
2006/0246836	A1	11/2006	Simon	455/3.01
2007/0066272	A1	3/2007	Vassiliou et al.	
2007/0189410	A1	8/2007	Zeng	375/267
2007/0223612	A1	9/2007	Simon	375/265
2009/0252266	A1	10/2009	Heinemann et al.	375/362

FOREIGN PATENT DOCUMENTS

DE	10 2006 015 393	4/1998
EP	0 837 609	4/1998
EP	1 670 150 A1	6/2006
EP	1 753 249	2/2007
GB	2 399 719 A	9/2004
WO	2003/009590 A1	1/2003
WO	2004062283 A1	7/2004
WO	2006/066617	6/2006
WO	2007/046672	4/2007

OTHER PUBLICATIONS

International Preliminary Report on Patentability, PCT/US2006/020599, Nov. 30, 2007.

“Digital Video Broadcasting (DVB); DVB mega-frame for Single Frequency Network (SFN) synchronization”, European Broadcasting Union, ETSI TS 101 191 v1.4.1 (Jun. 2004).

Jintao Wang, et al., “A New Implementation of Single Frequency Network Based on DMB-T”, 2004 International Conference on Communications, Circuits and Systems, 2004, ICCAS 2004, vol. 1, Jun. 27-29, 2004, vol. 1, pp. 246-249.

International Search Report and Written Opinion of the International Searching Authority, PCT/US06/20599, Aug. 31, 2007.

International Search Report and Written Opinion of the International Searching Authority, PCT/US06/07265, Sep. 4, 2007.

International Preliminary Report on Patentability and Written Opinion of the International Searching Authority, PCT/US2006/022300, Dec. 27, 2007.

International Preliminary Report on Patentability and Written Opinion of the International Application, PCT/US2006/007265, Oct. 4, 2007.

“ATSC Standard: Synchronization Standard for Distributed Transmission (A/110)”, Advanced Television Systems Committee (Jul. 14, 2004).

“ATSC Standard: Synchronization Standard for Distributed Transmission, Revision A (A/110A)”, Advanced Television Systems Committee (Jul. 19, 2005).

Whitaker, J. C., “Standard Handbook of Video and Television Engineering”, Chapter 17.2 “ATSC DTV Received Systems”, pp. 17-63 to 17-99 (2000).

“Lecture 4: Digital Television The DVB transport stream”, obtained from <http://www.abo.fi/~jbjorkqv/digitv/lect4.pdf> (last visited May 4, 2006).

Wang, X. et al., “Transmitter Identification in Distributed Transmission Network and Its Applications in Position Location and a New Data Transmission Scheme”, NAB Broadcast Engineering Conference, Las Vegas, NV, p. 511-520 (Apr. 16-21, 2005).

Vogel, W. J., et al., “Propagation Effects and Satellite Radio Design”, Paper No. 1445, Maastricht Exhibition and Congress Centre (MECC) Maastricht, the Netherlands (Aug. 17-24, 2002).

Patel, C. B., et al., “Proposal to ATSC Subcommittee T3/S9 to Provide 8-VSB with a Repetitive-PN1023 Signal for Rapidly and Reliably Initializing Tracking in an Adaptive Equalizer Despite Adverse Multipath Conditions” (Apr. 12, 2001).

Raghunandan, K., “Satellite Digital Audio Radio Service (SDARS) System Architecture and Receiver Review”, IEEE (Oct. 27, 2005).

Owen, H., “Proposed Modifications to ATSC Digital Television Standard to Improve Performance in the Face of Dynamic Multipath for both Fixed and Mobile Operation”, Sarnoff Corporation, Princeton, NJ (Apr. 2, 2001).

“ATSC Technology Group Report: DTV Signal Reception and Processing Considerations”, Doc. T3-600r4, Advanced Television Systems Committee (Sep. 18, 2003).

Proposal for Enhancement of ATSC RF Transmission System (Revision to A/53), submitted by Samsung, Draft ver. 1.0 (Sep. 16, 2004).

Citta, R., et al., “ATSC Transmission System: VSB Tutorial”, Zenith Electronics Corporation, Symposium Handout, Montreux Symposium (Jun. 12, 1997).

“ATSC Recommended Practice: Design of Synchronized Multiple Transmitter Networks (A/111)”, Advanced Television Systems Committee (Sep. 3, 2004).

Lee, Y., et al., “ATSC Terrestrial Digital Television Broadcasting Using Single Frequency Networks”, ETRI Journal, vol. 26, No. 2, pp. 92-100, Apr. 2004.

“ATSC Digital Television Standard (A/53) Revision E”, Advanced Television Systems Committee (Dec. 27, 2005).

International Search Report and Written Opinion of the International Searching Authority, PCT/US06/015317, May 14, 2008.

International Search Report and Written Opinion of the International Searching Authority, PCT/US06/07251, May 20, 2008.

* cited by examiner

FIG. 1

Prior Art

100

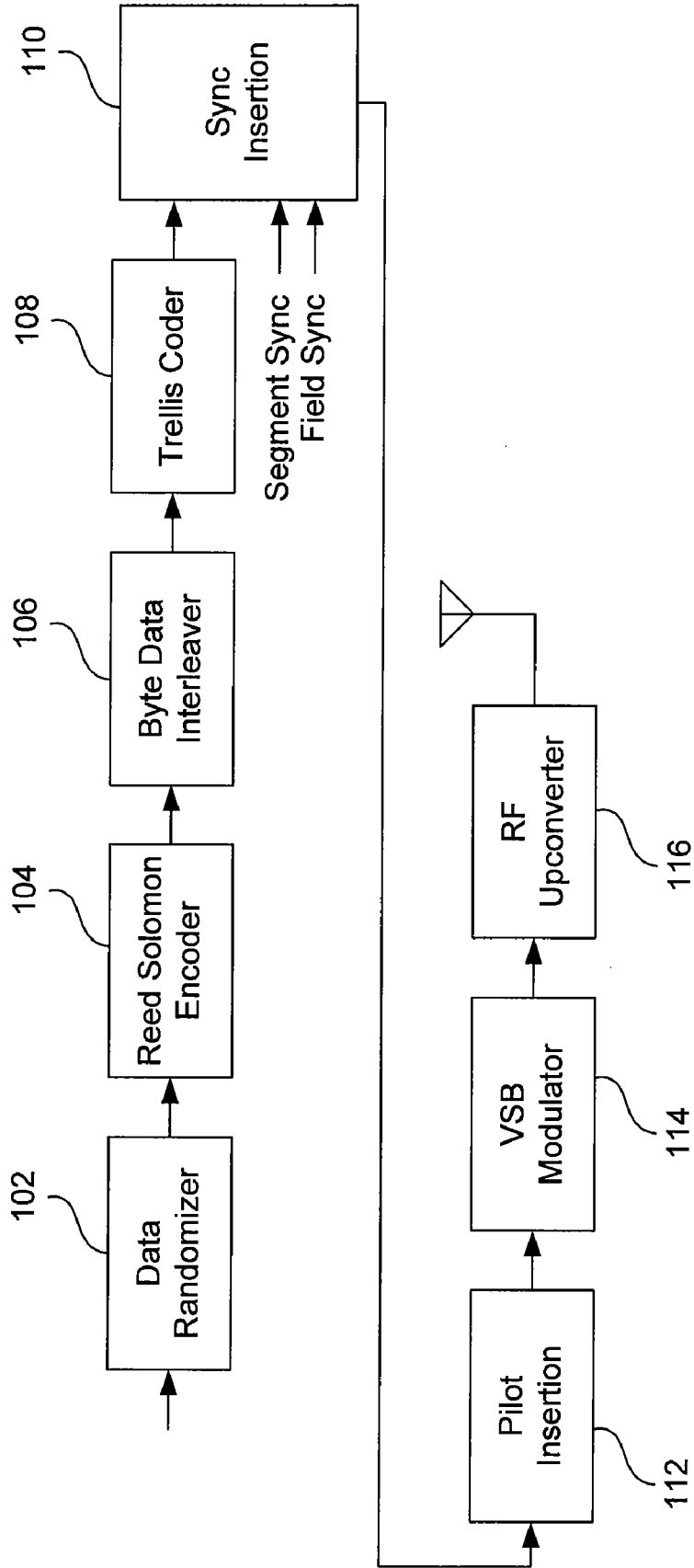

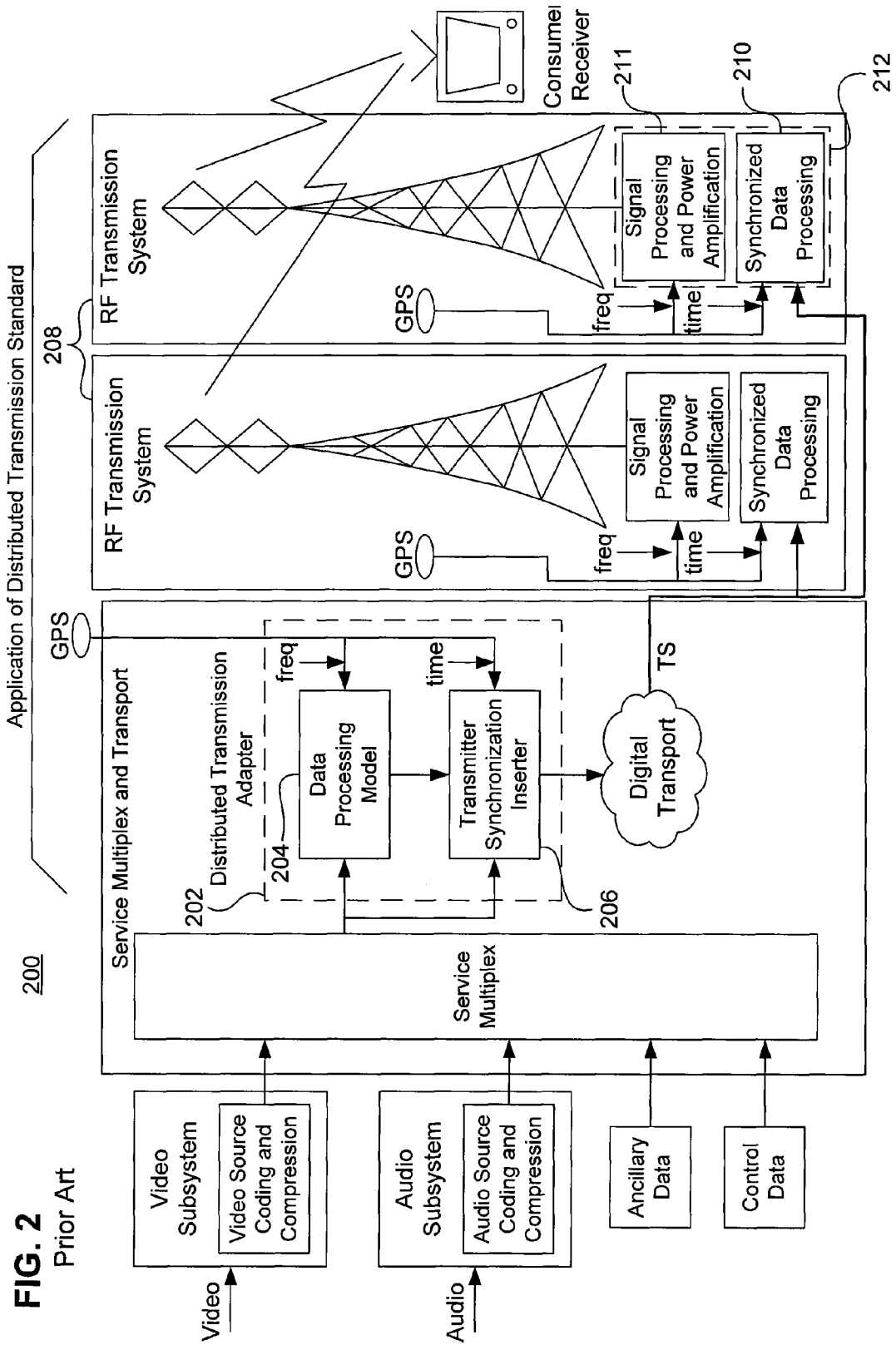

FIG. 2
Prior Art

FIG. 3

Prior Art

Syntax	No. of Bits	Format
DTx_packet (){		
reserved	8	0xFF
for (i=0; i<12; i++) {		
trellis_code_state	8	riuimsbfpw
}		
synchronization_time_stamp	24	uimsbf
maximum_delay	24	uimsbf
network_identifier_pattern	12	uimsbf
stream_locked_flag	1	bslbf
reserved	1	'1'
packet_number	10	uimsbf
reserved	32	0xFFFFFFFF
tx_group_number	8	uimsbf
for (i=0; i<16; i++) {		
tx_address	12	uimsbf
tx_identifier_level	3	uimsbf
tx_data_inhibit	1	bslbf
tx_time_offset	16	tcimsbf
tx_power	12	uipfmsbf
reserved	4	'1111'
}		
reserved	320	for (i=0; i<40; i++) 0xFF
DTxP_ECC	160	uimsbf
}		

FIG. 4

Prior Art

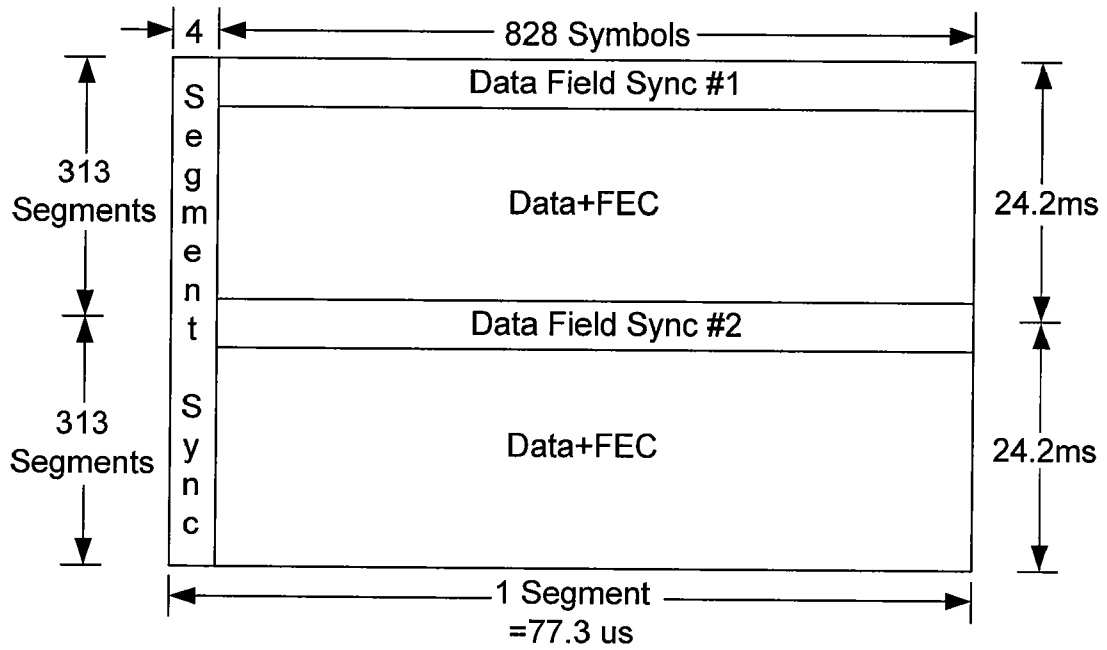

FIG. 5

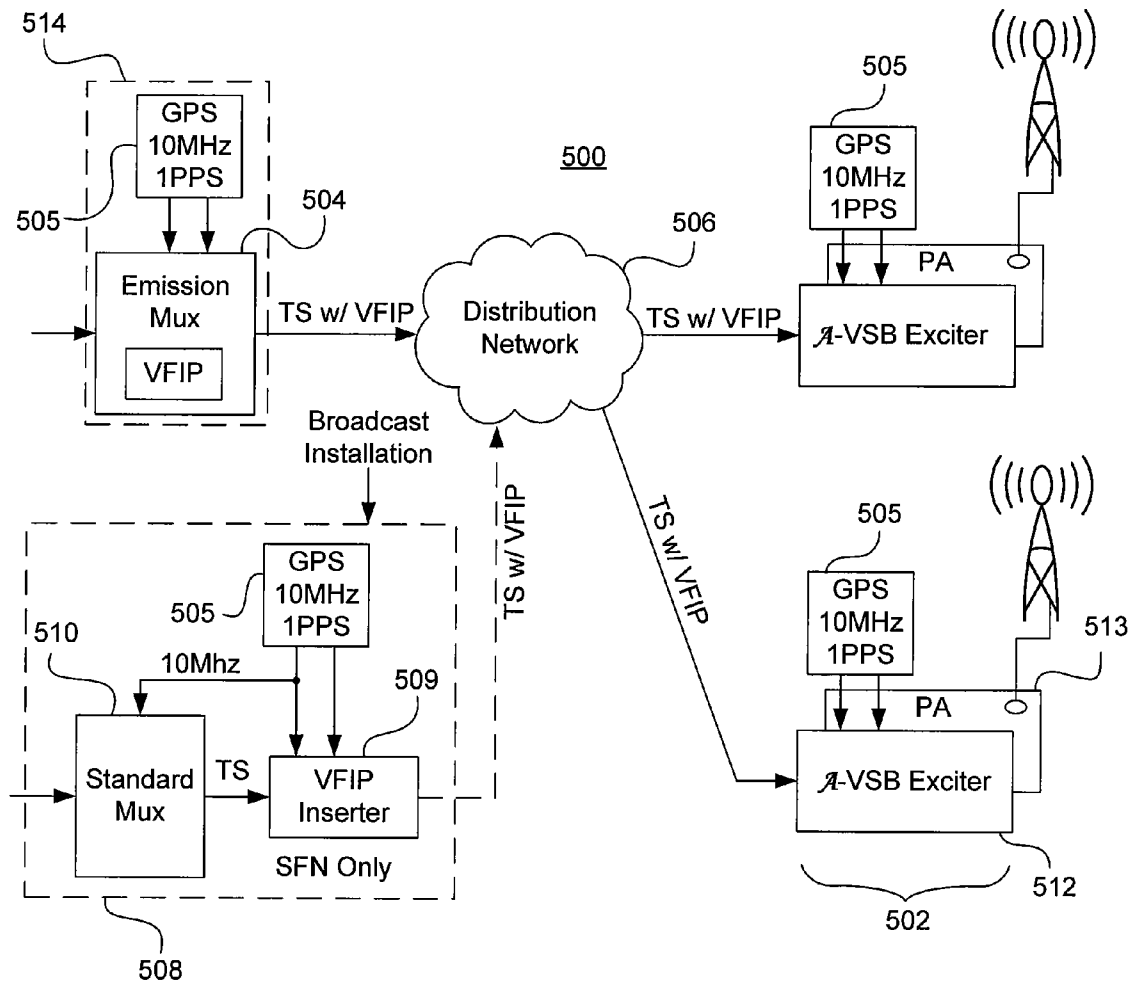

FIG. 6

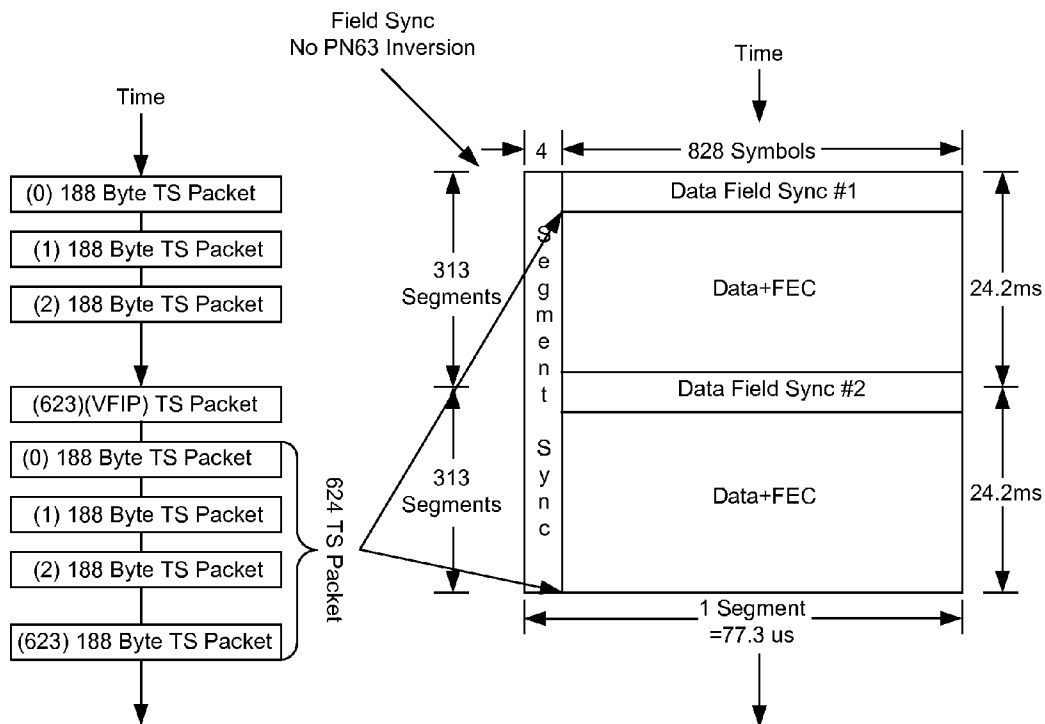
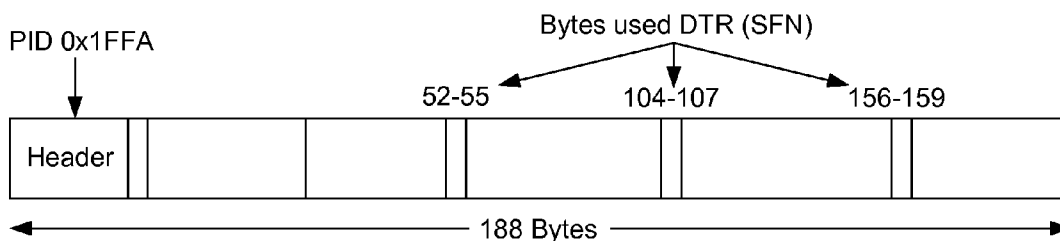
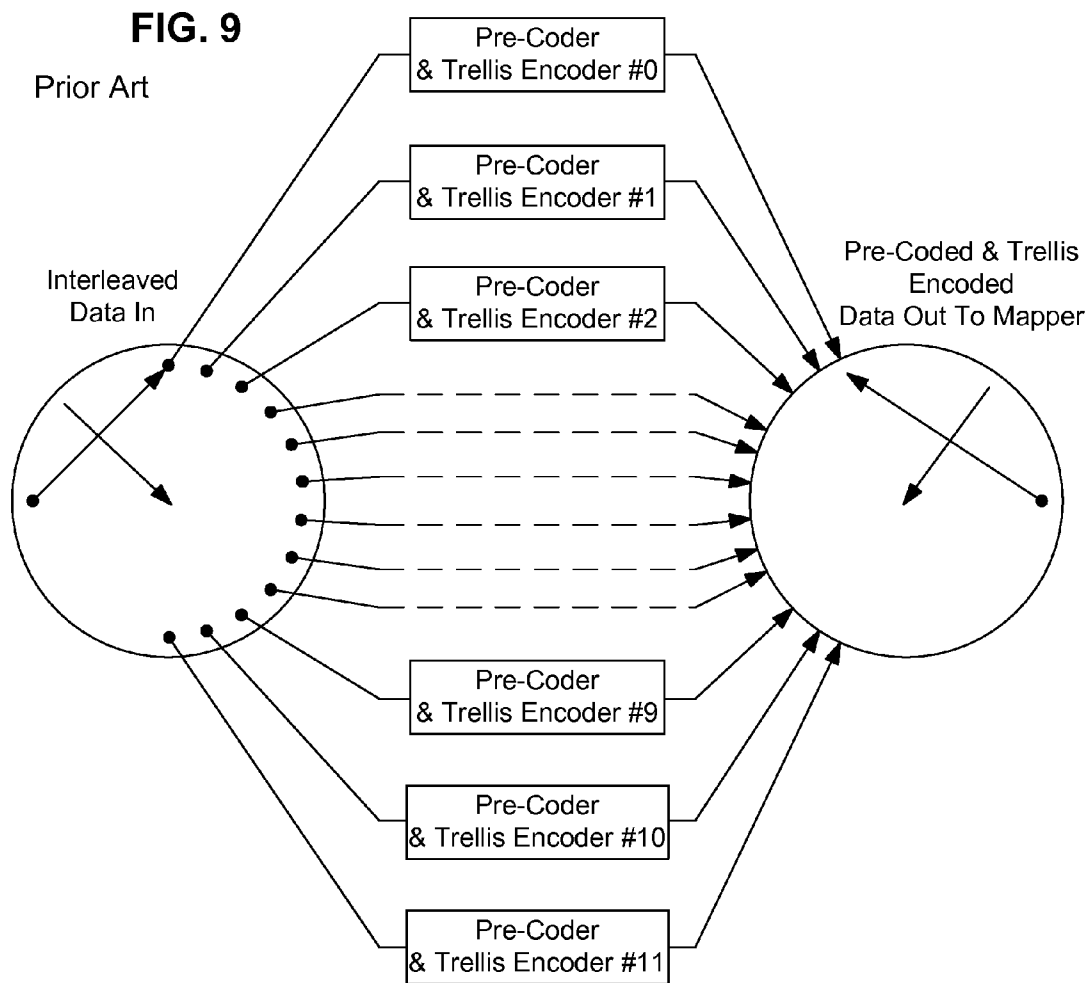
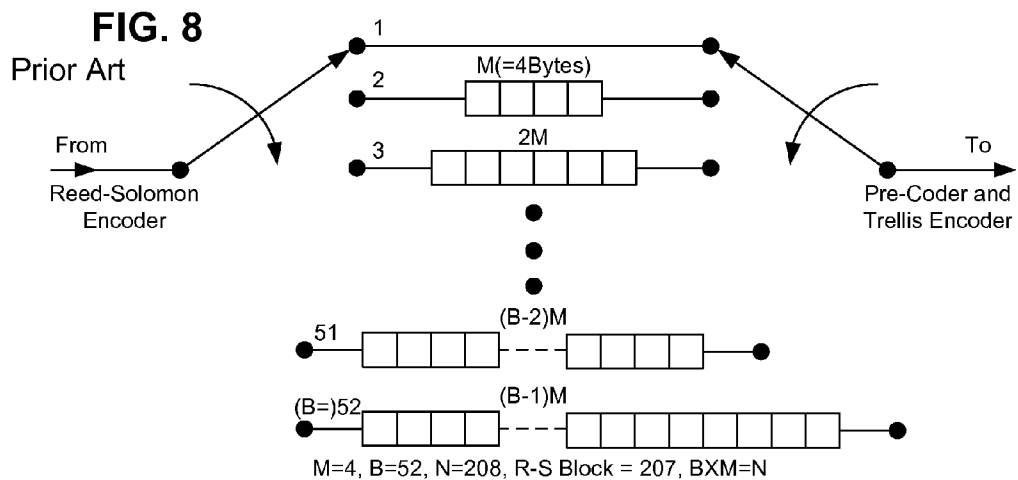

FIG. 7





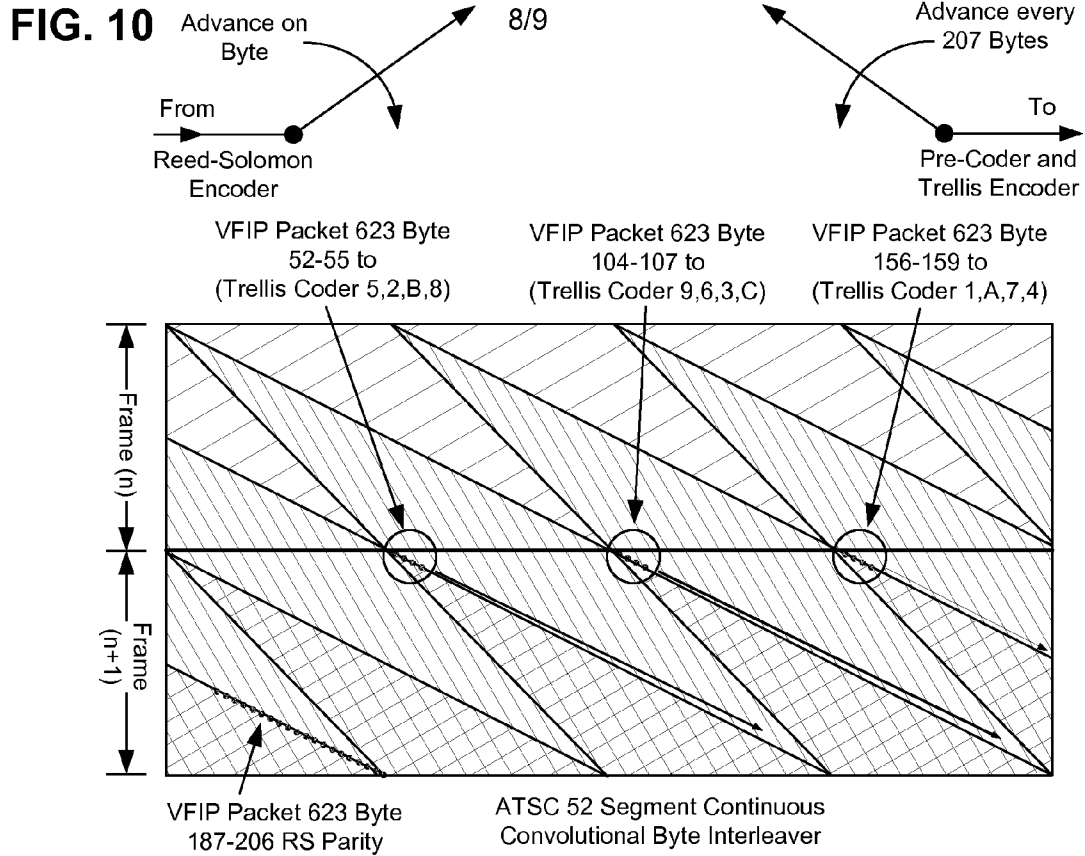

FIG. 11

Syntax	# bits	
VSB_Init_Packet({		
Transport_packet_header	32	
periodic_flag	1	} Period Of VFIP
periodic_value	8	
sync_time_stamp	24	} Network Delay Compensation
maximum_delay	24	
network_ID	12	
For (i=0; i<20 i++) {		
tx_address	12	
tx_ID_level	3	
tx_Data_Inhibit	1	
tx_time_offset	16	} Individual Tx Delay
tx_power }	12	
Reserved stuff bytes DTR	96	
Reserved future use	xxx	
VFIP_FEC }	160	} 20 Bytes RS Parity

FIG. 12

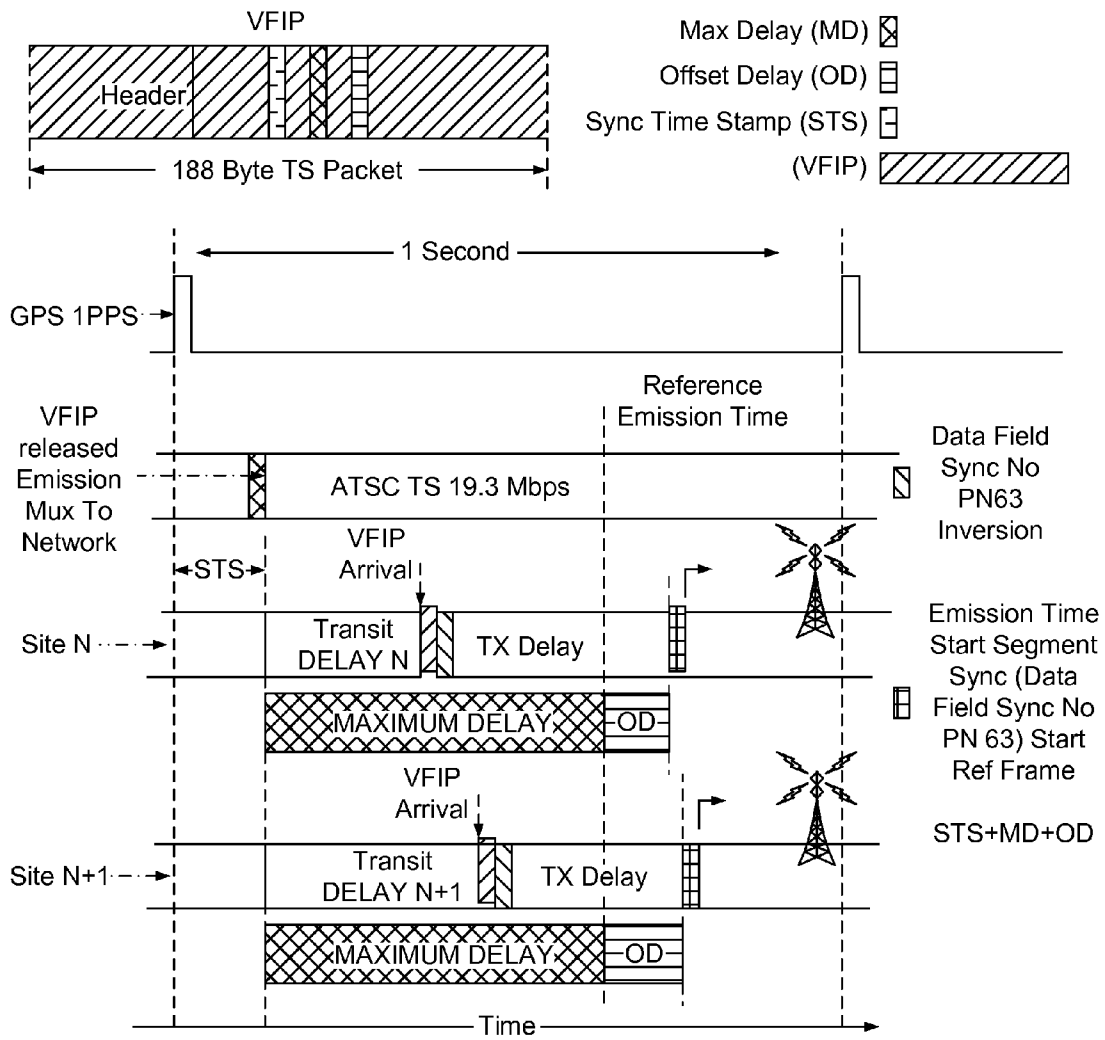
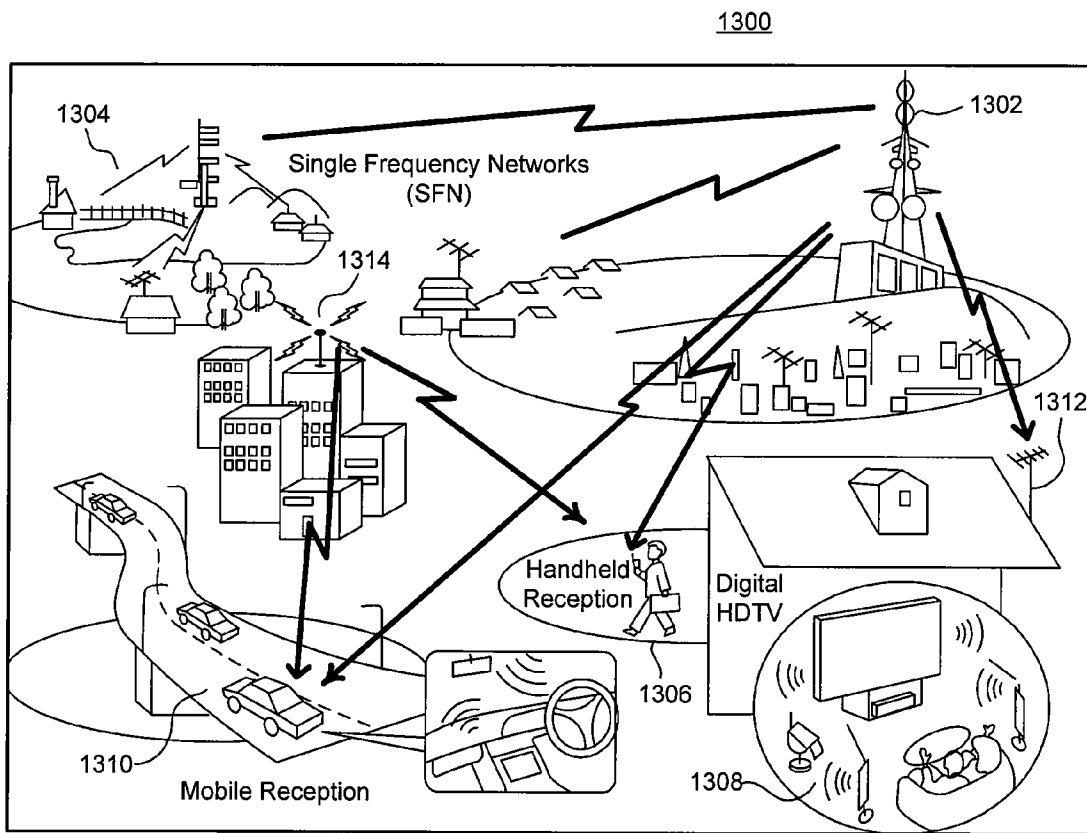

FIG. 13



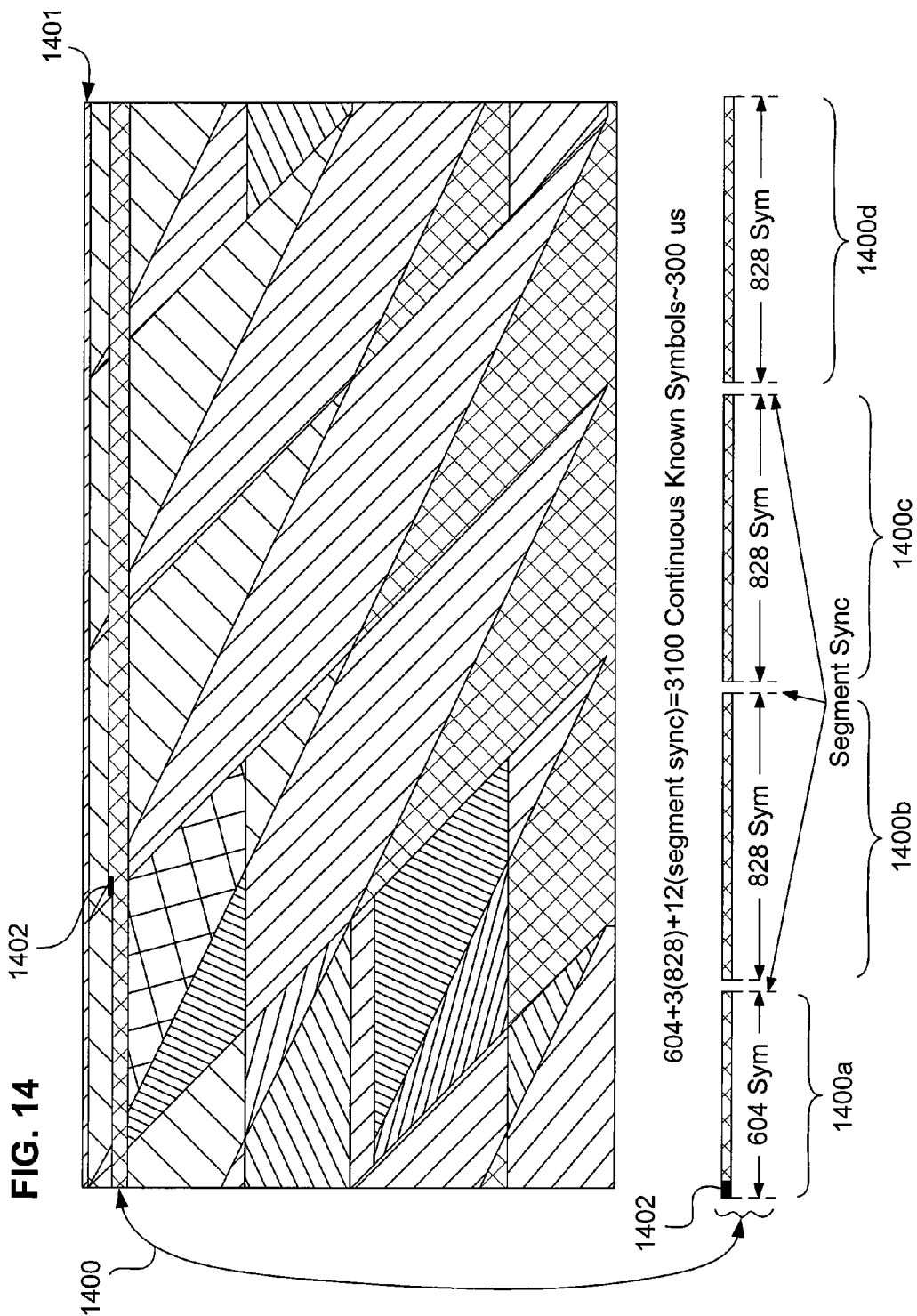

FIG. 15

Bytes	Packets
56	265-311
57	266-311
58	267-311
59	268-311
108	265-311
109	266-311
110	267-311
111	268-311
5	266-311
6	267-311
7	268-311
160	265-311
161	266-311
162	267-311
163	276-311
5	0-5
6	0-6
7	0-7
56	0-4
57	0-5
58	0-6
59	0-7
108	0-4
109	0-5
110	0-6
111	0-7
160	0-4
161	0-5
162	0-6
163	0-7

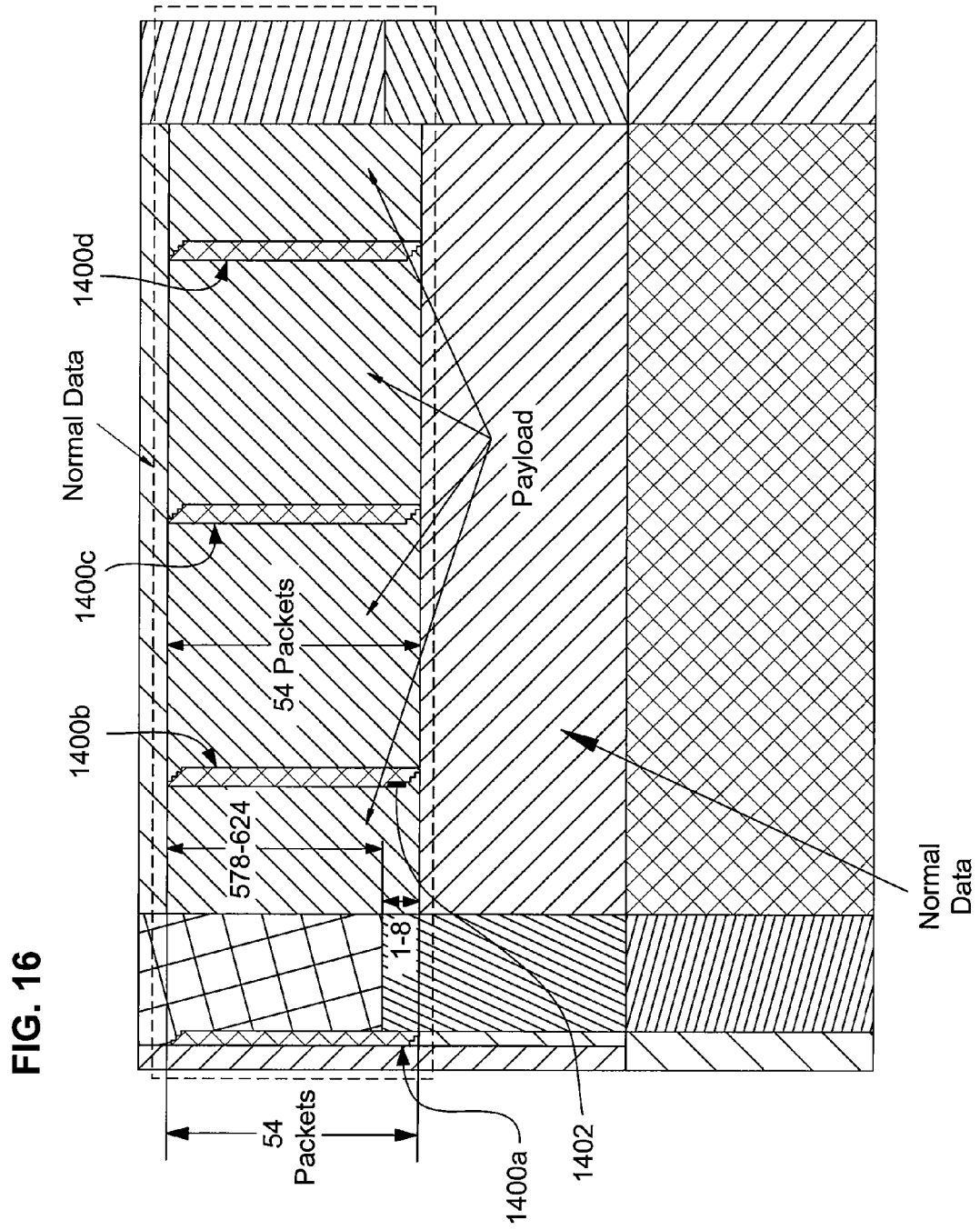

FIG. 16

FIG. 17

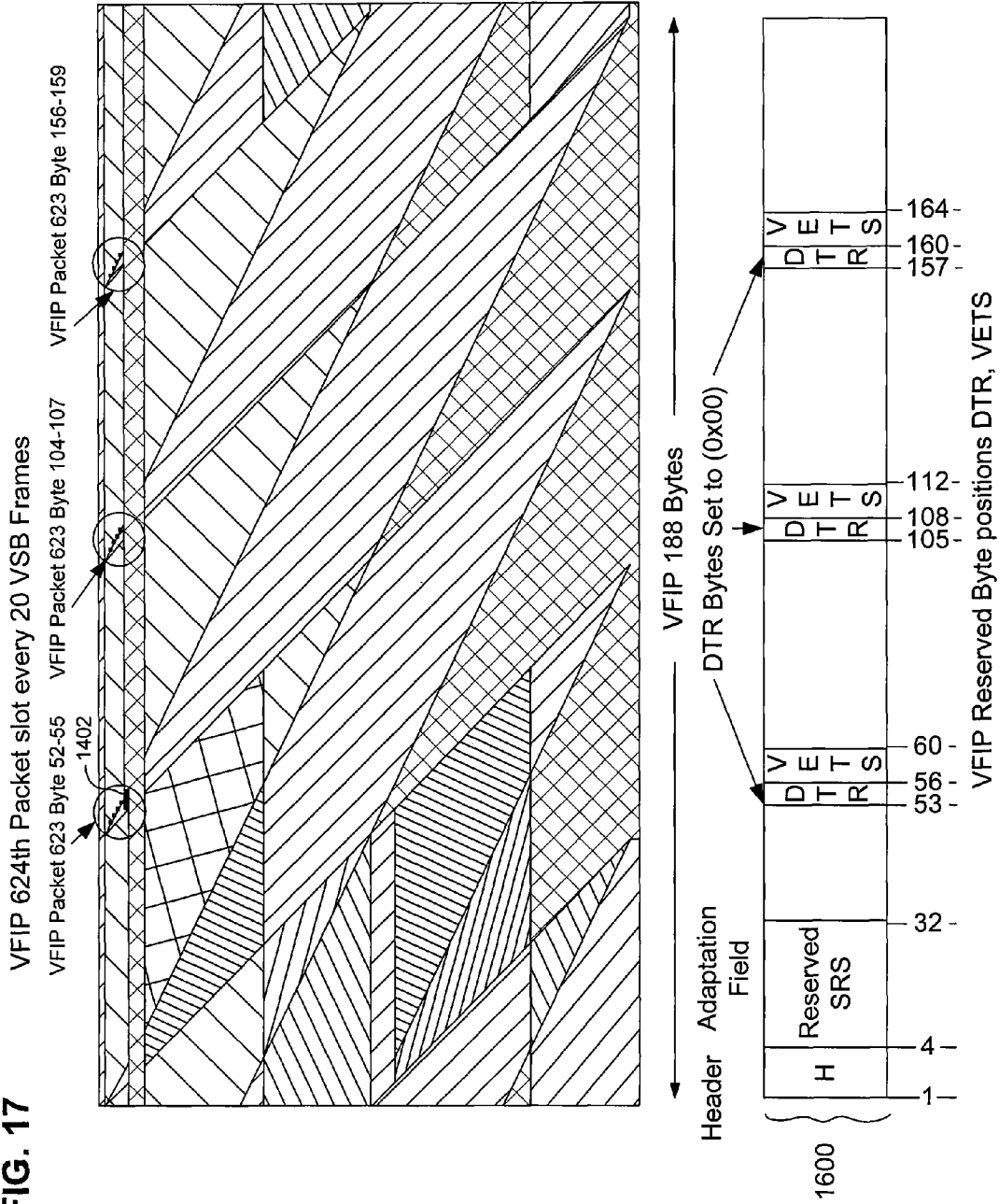
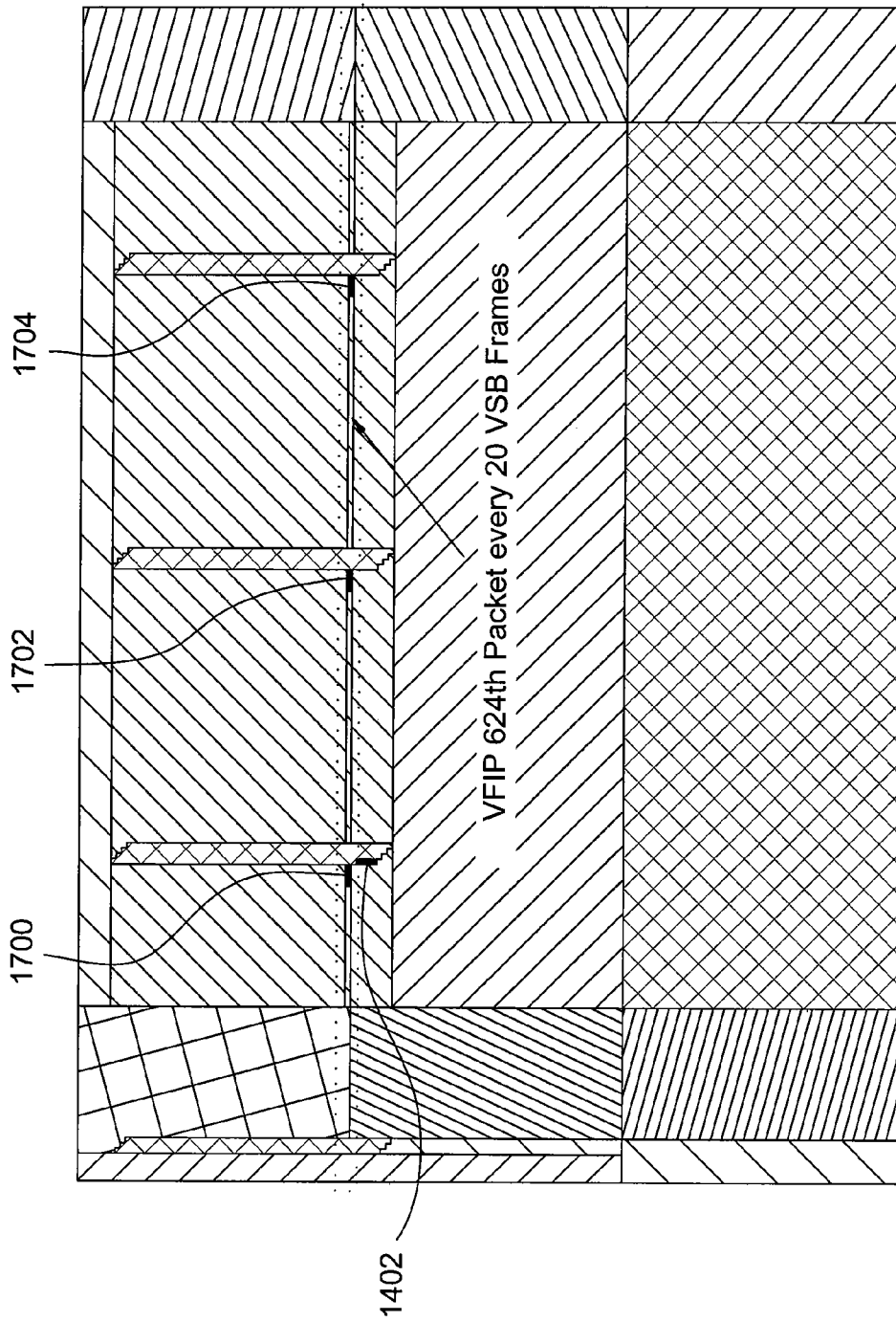

FIG. 18



**APPARATUS, SYSTEMS, METHODS AND
COMPUTER PRODUCTS FOR PROVIDING A
VIRTUAL ENHANCED TRAINING
SEQUENCE**

CROSS REFERENCE TO RELATED
APPLICATIONS

This application is a continuation-in-part of U.S. patent application Ser. No. 11/276,434, filed Feb. 28, 2006, and a continuation-in-part of U.S. patent application Ser. No. 11/276,453, filed Feb. 28, 2006; those applications, and this, claim priority to, and the benefit of, U.S. Provisional Patent Application Ser. No. 60/657,416, filed Mar. 2, 2005, and U.S. Provisional Application Ser. No. 60/740,424, filed Nov. 29, 2005, and this application also claims priority to, and the benefit of, U.S. Provisional Application Ser. No. 60/684,407, filed May 25, 2005; all of the mentioned prior applications are hereby incorporated herein by reference in their entirety.

BACKGROUND OF THE INVENTION

1. Field of the Invention

The present invention generally relates to adaptive equalizers, and more particularly to technology for deterministically communicating a training sequence to an adaptive equalizer to cause the initialization of the equalizer despite adverse multipath conditions.

2. Related Art

A single-frequency network (SFN) is a collection of transmitters operating on the same frequency for carrying the same information to receivers in a given area. The transmitters emit identical signals, several of which may be received more or less simultaneously by individual receivers. One advantage of using multiple transmitters instead of one powerful transmitter is that multiple transmitters provide alternate paths for the signal to enter a structure, such as a house, thereby providing better reception. In mountainous areas, for example, it may be difficult to find one location capable of serving all the population centers in the area, since they are often located in valleys. Multiple transmitters can be strategically placed to cover such small areas and fill in the gaps.

One application of SFNs is for transmission of digitally encoded data such as digital television (DTV), the system and related standards for which have been established by the Advanced Television Systems Committee ("ATSC"). Under the ATSC's DTV standard (or A/53 standard), hereby incorporated herein by reference in its entirety, it is possible to transmit large amounts of data including high definition pictures, high quality sound, multiple standard definition pictures, and other ancillary related or unrelated communications, which may be accessible by using a computer or television set.

The DTV standard includes the following layers: the video/audio layer, compression layer, transport layer, and the transmission layer. At the top of the hierarchy is the uncompressed digital signal in one of the various digital data formats (e.g., video/audio formats). The data stream that corresponds with the video/audio layer is known as the elementary stream.

The compression layer compresses the elementary stream into a bitstream with a lower data rate. In the ATSC DTV standard, MPEG-2 compression is used for the video and the Dolby AC-3 compression is used for the audio. The compressed bitstream, in turn, may be packetized and multiplexed with other bitstreams into a higher data rate digital bitstream in the transport layer by a multiplexer. The MPEG-2 transport protocol defines (among several other things) how to pack-

etize and multiplex packets into an MPEG-2 transport stream. The result is a stream of highly compressed data packets in a multiplexed bitstream which may include multiple programs and/or multiple data signals.

The multiplexed bitstream from the transport layer is modulated onto a radio frequency ("RF") carrier in the transmission layer by a transmission system. The terrestrial broadcast mode utilized in the current ATSC DTV standard to transmit digital signals over the airwaves is called eight-level Trellis Coded vestigial sideband (8T-VSB).

FIG. 1 is a block diagram of a well known Trellis-coded 8T-VSB transmitter **100** used in an RF transmission system. The transmitter receives the incoming data packets of interspersed video, audio, and ancillary data, and, using a data randomizer **102**, randomizes the data to produce a flat, noise-like spectrum. A Reed-Solomon (RS) encoder **104**, known for its good burst noise correction capability and data overhead efficiency, RS-encodes the randomized data to add parity bytes to the end of each data packet. In turn, the data is convolutionally interleaved (i.e., spread out) over many data segments by a byte data interleaver **106**.

A pre-coder and Trellis encoder **108** (referred to in the specification hereafter as a "Trellis coder") adds additional redundancy to the signal in the form of multiple data levels, creating multilevel data symbols for transmission. A synchronization insertion component **110** multiplexes the segment and frame synchronizations with the multilevel data symbols before a DC offset is added by a pilot insertion component **112** for creation of the low-level, in-phase pilot. Segment and frame synchronizations are not interleaved. A VSB modulator **114** provides a filtered intermediate frequency (IF) signal at a standard frequency, with most of one sideband removed. Finally, an RF upconverter **116** translates the signal to the desired RF channel.

Multipath propagation is a common problem in single transmitter broadcast environments because it places a burden on a receiver equalizer's ability to handle signal echoes. In a distributed transmission system, where multiple transmitters are utilized, the multipath propagation problem is compounded. It is necessary, therefore, to synchronize or adjust the timing of the SFN system to control the delay spread seen by receivers in areas of SFN induced multipath not to exceed delay handling range of receiver equalizers and become problematic.

In addition, the output symbols of each transmitter are based on the transport stream received, how they are mapped into a Data Frame, and the initial states of the Trellis coders, which are normally random. When the transmitters emit the same symbols as one another for the same data inputs, they are said to be made "coherent". If the transmitters in an SFN are not synchronized, they will not emit coherent symbols.

The ATSC has promulgated a standard, referred to as the A/110 standard, which provides rules for synchronization of multiple transmitters emitting Trellis-coded 8T-VSB signals in an SFN or distributed transmission system (DTx) to create a condition which allows multiple transmitters being fed by the same transport stream to produce coherent symbols. SFN and DTx are to be understood to be synonymous terms. The A/110 standard is hereby incorporated herein by reference in its entirety.

FIG. 2 shows a block diagram of an ATSC SFN system **200** using A/110 distributed transmission (DTx). SFN system **200** includes three elements: an external time and frequency reference (shown as GPS), a distributed transmission adapter (DTxA) **202** situated at the source end of the distribution (or studio-to-transmitter link (STL)) subsystem, and plural RF transmission systems **208**. DTxA includes two basic blocks:

a transmitter synchronization inserter **206** and a data processing model **204**. Transmitter synchronization inserter **206** inserts information (described in more detail below) into the transport stream (TS). The data processing model **204** is a model of the data processing in an ATSC modulator which serves as a master reference to the slaved synchronized data processing blocks **210** in the RF transmission systems **208**. Generally, each RF transmission system **208** includes two blocks: synchronized data processing block **210** and signal processing and power amplification block **211**, which collectively are sometimes referred to as a “modulator” **212**. These low level stages of the transmitter are also generally referred to as the “exciter” component. Herein the terms exciter and modulator are use interchangeably.

In an ATSC SFN system each synchronized data processing block **210** also includes a Trellis-coded 8-VSB transmitter **100** discussed above with reference to FIG. 1. As shown in FIG. 2, the DTxA produces a transport stream (TS) and feeds this stream to all of the synchronized data processing blocks **210**.

FIG. 3 shows the structure of a distributed transmission packet in accordance with the A/110 standard and FIG. 4 depicts a VSB data frame, which includes packets of data and forward error correction (FEC), and data field synchronization (DFS) fields.

The first data segment of each data field includes a training sequence (also referred to as a “training signal”), which is used by an equalizer in a receiver to initiate compensation for linear channel distortions, such as tilt and ghosts caused by transmission channel interference or from imperfect components within a transmitter or receiver.

The particular training sequence is defined in the ATSC A/53 standard and is referred to as the PN511 sequence. More particularly, the PN511 sequence immediately that follows the data segment sync in the initial data segment of each data field is a sequence of 511 symbols having normalized modulation levels each of which is either -5 or $+5$. This sequence is also stored in a receiver.

The receiver’s equalizer uses the training sequence to generate initial weighting coefficients (also referred to as “tap coefficients”) for the equalizer’s filter taps based on a time-domain impulse response of the transmission/reception channel. Particularly, the equalizer generates an estimate of the error present in the output signal by comparing the received sequence and the pre-stored sequence and computing a cross-correlation (also referred to as “autocorrelation”) with various delayed data signals. These correlations correspond to the adjustments that need to be made to the tap coefficients to reduce the linear distortion error.

If multipath reception conditions are changing, it is important that the equalization filtering in the receiver be able to initialize its weighting coefficients reasonably quickly and accurately. As is well known, the selection of the signal used for training plays an important role as to how rugged a receiver can be against spurious interference, transmitter and receiver generated distortion, and the like. While the training sequence described in the ATSC A/53 standard may be adequate to train receivers in fixed services, it is not always adequate to train receivers quickly in highly mobile devices in harsh environments (e.g., due to multipath). Accordingly, it is preferable that the PN sequence be sufficiently long to improve equalizer initialization despite harsh multipath reception conditions. It is also preferable to have the option to provide a customized training sequence that can be inserted into a transport stream which can be ignored by legacy receivers.

The A/110 standard requires the following three ATSC system elements to be synchronized: 1. frequency synchronization of the pilot or carrier frequencies, 2. data frame synchronization, and 3. pre-coder and Trellis encoder (Trellis coder) synchronization. A description of how these three elements are synchronized in a group of separately located transmitters follows.

According to the A/110 standard, control of two specific transmitter frequencies is required. First the RF frequency of the transmitted signal, as measured by the frequency of its pilot, must be accurately controlled to maintain frequencies of the transmitters close enough to one another that the receiver is not over-burdened with apparent Doppler shift between the signals. The symbol clock frequency must be accurately controlled to allow the output symbol stream to maintain stable, relative, time offsets between transmitters in a network. A flag, `stream_locked_flag`, in the DTxP packet structure is used to identify one of two options for performing symbol frequency synchronization. This flag is a 1-bit field that indicates to a slave transmitter whether it is to lock its symbol clock frequency to the incoming transport stream clock frequency (normal ATSC methodology) or to lock its symbol clock frequency to the same external precision reference frequency used throughout the network (e.g., GPS).

Data frame synchronization requires all of the slave modulators **212** in an SFN to use the same transport stream (TS) packet to start a VSB data frame (FIG. 4). In the current ATSC A/110 standard, this is accomplished by using DTxA **202** by inserting a cadence signal. In particular, a cadence signal (CS) is inserted at a deterministic point in time, once every 624 packets, into the MPEG-2 transport stream from the DTxA to each of the modulators **212**. Dividing the rate of CS by half produces a Data Field Sync (DFS). The A/53 standard specifies that the data randomizer **102**, and data interleaver **106** and intra-segment interleaver in part of **108** in the slave synchronized data processing blocks **210** shall all slave to DFS.

In addition, the A/110 standard provides that it is necessary to develop a state condition for the Trellis coder memories to be applied at a specific epoch in the data stream simultaneously by all RF transmission systems **208** in a network. According to the A/110 standard, “in order to put the precoders and trellis encoders of all the transmitters in a network in the same state at the same time, it is necessary to ‘jam sync’ them to the trellis coder model in the Distributed Transmission Adapter.” In other words, Trellis coders cannot be synchronized by identifying an epoch in the transport stream (TS). Instead, to place the Trellis coders of all the transmitters in a network in the same states at the same time, a sample of all Trellis coder states in the data processing model **204** is captured, and this data is carried in an element of the DTxP, `Trellis_code_state` (FIG. 3), from DTxA **202** to all the slave modulators **212**.

At a later, deterministic point in time, the Trellis code states that have been extracted from the DXP are used to initialize the memory of each Trellis coder in the slave modulators **212**, to the state of the data processing model **204** in DTxA **202**. Once this has been performed, the modulator Trellis coders are synchronized and all the modulators **212** should produce “coherent symbols.” In addition, the DTxA indicates operating mode to the transmitters and provides information to be transmitted in the data field sync data segment through a field rate side channel, which carries information updated regularly at a data field rate.

The method used by A/110 standard to achieve Trellis coder synchronization adds much complexity to the overall SFN distributed transmission system design by requiring the DTxA **202** to sample the data processing model’s Trellis

5

coder states. Moreover, the A/110 does not provide the ability to post process data in the modulator once it exits the DTxA. A change of one bit in data stream after DTxA will break the Trellis code synchronization scheme thus making it difficult, if not impossible, to add enhancements to ATSC standard A/53. Moreover, as more transmitters are added in a multi-tier (e.g., distributed-translator) scheme the complexity of an SFN under the A/110 standard grows since an additional data processing model **204** must be added for each tier. Thus, what is needed is a technology that is scalable in SFN applications without adding additional complexity or constraints on system extensibility of the overall system.

Given the foregoing, also needed are improved apparatus, systems, methods and computer program products for communicating training sequences to receivers.

BRIEF DESCRIPTION OF THE INVENTION

The present invention meets the above-identified needs by providing apparatus, systems, and methods for producing coherent symbols in a single frequency network and for communicating training sequences to the equalizers of digital receivers.

An advantage of the present invention is that it is backward compatible with existing ATSC standards and legacy ATSC receivers.

Another advantage of the present invention is that it provides a deterministic Trellis reset.

Yet another advantage of the present invention is that it provides deterministic VSB frame synchronization and can do so simultaneously with the deterministic Trellis reset in an efficient manner.

Still another advantage of the present invention is that it provides a deterministic training sequence to a receiver.

Another advantage of the present invention is that it provides a training sequence to a receiver that is variable in length.

In one aspect of the present invention, a system, method, apparatus and computer code for communicating a training sequence for initializing an equalizer in a digital receiver are provided including receiving a digital signal containing data to be broadcast from a digital RF transmitter and inserting the training sequence into the digital signal deterministically such that a predetermined sequence of symbols are communicated to the digital receiver.

Further features and advantages of the present invention as well as the structure and operation of various embodiments of the present invention are described in detail below with reference to the accompanying drawings.

BRIEF DESCRIPTION OF THE DRAWINGS

The features and advantages of the present invention will become more apparent from the detailed description set forth below when taken in conjunction with the drawings in which like reference numbers indicate identical or functionally similar elements.

FIG. 1 is a block diagram of a Trellis-coded 8-VSB transmitter **100**.

FIG. 2 shows a block diagram of an ATSC SFN system using A/110 distributed transmission where multiple Trellis coded 8T-VSB transmitters are fed by the same transport stream.

FIG. 3 shows the structure of distributed transmission packet in accordance with the A/110 standard.

FIG. 4 depicts a VSB data frame in accordance with the ATSC A/53 standard.

6

FIG. 5 is a system diagram of an exemplary SFN in accordance with an embodiment of the present invention.

FIG. 6 illustrates a method for inserting VSB frame initialization packets (VFIPs) in accordance with an embodiment of the present invention.

FIG. 7 depicts a structure of a VSB frame initialization packet (VFIP) in accordance with an embodiment of the present invention.

FIG. 8 is a block diagram of a data interleaver for interleaving a transport stream with VFIPs in accordance with an embodiment of the present invention.

FIG. 9 is a block diagram of an interleaver commutator feeding interleaved VFIPs to Trellis coders in accordance with an embodiment of the invention.

FIG. 10 depicts the output of an ATSC **52** segment continuous convolutional byte interleaver with an interleaved VFIP in accordance with an embodiment of the present invention.

FIG. 11 shows the structure of a VFIP in accordance with an embodiment of the present invention.

FIG. 12 depicts SFN synchronization timelines showing the timing syntax and semantics for an ATSC SFN in accordance with an embodiment of the present invention.

FIG. 13 depicts a single frequency network environment including mobile, indoor, handheld, and fixed services modes capable of receiving training sequences in accordance with the present invention.

FIG. 14 depicts the output of an ATSC **52** segment continuous convolutional byte interleaver including an interleaved training sequence in accordance with an embodiment of the present invention.

FIG. 15 depicts an exemplary table corresponding to the packets and byte positions used to create a VETS, in accordance with an embodiment of the present invention.

FIG. 16 depicts the input to the ATSC **52** segment continuous convolutional byte interleaver including the interleaved training sequence components in accordance with an embodiment of the present invention.

FIG. 17 depicts the output of an ATSC **52** segment continuous convolutional byte interleaver including an interleaved training sequence as well as deterministic Trellis reset (DTR) bytes in accordance with an embodiment of the present invention.

FIG. 18 depicts the input to the ATSC **52** segment continuous convolutional byte interleaver including the interleaved training sequence components as well as deterministic Trellis reset (DTR) bytes in accordance with an embodiment of the present invention.

DETAILED DESCRIPTION

The present invention is now described in more detail herein in terms of an exemplary apparatus, systems, methods and program products for producing coherent symbols in a single frequency network and for communicating training sequences to the equalizers of digital receivers. This is for convenience only and is not intended to limit the application of the present invention. In fact, after reading the following description, it will be apparent to one skilled in the relevant art(s) how to implement the following invention in alternative embodiments (e.g., multi-frequency networks).

In one aspect of the present invention, the following required ATSC synchronizations are performed: 1. frequency synchronization of the pilot or carrier frequencies, 2. data frame synchronization, and 3. pre-coder/trellis coder synchronization.

Frequency synchronization of the pilot or carrier is achieved by locking the carrier frequency of an exciter in the RF transmitter system to a reference from a GPS timebase.

The start of a data frame is determined (i.e., synchronized) by identifying a point in the transport stream via a special timing packet. Generally, a transport stream (TS) having a specialized timing packet is generated at a broadcast installation. The TS rate is locked to a GPS clock (e.g., 10 MHz), and the GPS temporal reference (e.g., one pulse per second (1PPS)) is used to construct the timing packet. The synchronization packets identify a cadence "epoch" point in the TS, which is used to slave all the data frames to be broadcasted from one or more RF transmission systems, and hence provide data frame synchronization (DFS).

The present invention further provides a deterministic initialization of the Trellis coder memories by creating packets with predetermined data patterns located at deterministic positions throughout a data frame. The predetermined data patterns are transmitted from the broadcast station to an exciter to cause its Trellis coder states to be initialized in a fixed predictable fashion. Data frame synchronization and Trellis coder synchronization can thus occur using a single initialization packet.

FIG. 5 is a system diagram of an SFN 500 in accordance with an embodiment of the present invention. A transport stream emitter 514 in a broadcast installation such as a studio or network operations center ("NOC") is fed a data stream (e.g. MPEG-2 data stream). Transport stream emitter 514 transmits the data stream to a distribution network 506 in the form of a transport stream (TS) having VSB frame initialization packets (VFIPs). VFIPs are specialized synchronization packets generated by an emission multiplexer 504 of the transport stream emitter 514. In one embodiment, a VFIP module within an emission multiplexer 504 generates VFIPs. The TS with a VFIP is transmitted to one or more transmission systems 502 through a distribution network 506 (e.g., fiber, satellite, microwave and the like). Emission multiplexer 504 is clocked by a GPS timebase 505.

Another transport stream emitter configuration may be used instead of transport stream emitter 514. Transport stream emitter 508, for example, provides broadcast installations with the ability to use a standard multiplexer 510 with a VFIP inserter unit 509. In this alternative transport stream emitter configuration, transport stream emitter 508 includes an external VFIP inserter unit 509 communicatively coupled to a standard multiplexer 510. A transport stream (TS) with VFIP packets is similarly communicated from transport stream emitter 508 to RF transmission systems 502 through distribution network 506.

RF transmission systems 502 downstream from the broadcast installation include an exciter 512 which can detect the VFIPs in the transport stream. In addition, RF transmission systems 502 include other components such as power amplifiers (PAs) 513. As noted above exciters are also sometimes referred to as modulators.

In one embodiment of the present invention, emission multiplexer 504 as well as all the other nodes in SFN 500 are clocked by a common timebase, GPS timebase 505. Frequency synchronization of the pilot or carrier is thus achieved by locking the carrier frequency of exciter 512 to the 10 MHz reference from the GPS timebase 505 to regulate the apparent Doppler shift seen by ATSC receiver from the SFN in overlapping coverage areas.

The following description of data frame synchronization and Trellis coder synchronization is applicable to both transport stream emitter configurations (514 and 508). For convenience, the following description is in terms of emission

multiplexer 504. In the foregoing discussion when appropriate corresponding components of transport stream emitter 508 are identified.

As explained above, data frame synchronization requires that all exciters in an SFN choose the same packet from the incoming TS to begin a VSB data frame. In the present invention, each exciter 512 follows the frame synchronization timing of emission multiplexer 504 to achieve initial frame synchronization and to maintain this condition.

Emission multiplexer 504, has its data rate locked to the GPS reference 505, and initiates frame synchronization by selecting one of the TS packets to begin a VSB Frame. Once an initial TS packet has been selected to start the count, emission multiplexer 504 counts 623 TS packets inclusive of the selected packet (e.g., 0-622) emission multiplexer 504 inserts a VFIP as the last (623) packet. This corresponds to a container of data (624 packets) which is equivalent to the payload in an ATSC A/53 VSB frame having 624 payload segments.

Emission multiplexer 504 inserts a VSB frame initialization packet (VFIP), as shown in FIG. 6. By the placement of VFIP in the last packet slot (623) signaling of VSB frame is made implicit. Upon reception of the VFIP, each exciter 512 is signaled to the start a new data frame after the last bit of VFIP packet is received. The cadence also referred to as timing or frame rate of the VSB frames is thus based on the frame synchronization timing which is maintained by emission multiplexer 504. Since emission multiplexer 504 is locked to GPS timebase 505, the 0-623 packet count becomes the cadence of the VSB frame rate. After the first VFIP insertion, additional VFIPs can be inserted subsequently thereafter at a predetermined periodicity (e.g., approximately once per second). For example, whenever emission multiplexer 504 inserts a VFIP, it will appear in the 623 slot as determined by a cadence counter in emission multiplexer. As described in more detail below, additional timing parameters can be adjusted based on values of particular fields in the VFIP.

FIG. 7 depicts the structure of a VFIP in accordance with one embodiment of the present invention. As shown in FIG. 7, VFIP includes a packet identifier (PID) field stored in the header portion of the VFIP packet. Exciter 512 identifies a VFIP packet by its PID. In an exemplary embodiment, exciter 512 identifies a packet as a VFIP packet when its PID value is 0x1FFA. After the VFIP packet has been read, exciter 512 inserts a VSB data field sync (DFS). The frame payload segments thus begins after Data Field Sync #1. Exciter 512 in turn makes a determination whether 312 TS packets have been received. If so, exciter 512 inserts additional DFSs per the A/53 standard.

As described in the ATSC A/53 standard, a DFS includes a series of pseudorandom number (PN) sequences of length 511, 63, 63, and 63 symbols, respectively. The PN63 sequences are identical, except that the middle sequence is of opposite sign in every other field sync. This inversion allows the receiver to recognize the alternate data fields comprising a frame. In Data Field Sync #1 all three PN63 sequences are in the same phase and in Data Field Sync #2 the middle PN63 sequence is inverted and the other two have the same phase. The exciter 512 inserts a DFS with no PN63 inversion directly after the last bit of the VFIP packet and then continues with normal VSB frame construction starting with next TS packet (0) as first data-segment of the next VSB frame.

If an exciter 512 has already been frame synchronized, a received VFIP packet can be used to verify the exciter is still in phase with frame cadence maintained in emission multiplier because of the implicit placement of VFIP in transport stream.

As explained above, it is also necessary to develop a state condition for the Trellis coder memories to be applied at a specific epoch in the data stream simultaneously by all transmitters in a network. The present invention uses a deterministic Trellis reset (DTR) to perform Trellis coder synchronization by forcing the Trellis coder to go into a known zero state as a pre-determined byte in the VFIP packet enters the Trellis coder.

Trellis coder synchronization is accomplished based on a priori knowledge of the location of the interleaved VFIP packet at the output of byte data interleaver **106** (FIG. 1) before the Trellis coder stage **108** (FIG. 1). With the knowledge of the output of the ATSC interleaver **106** once the data frame synchronization data has been achieved, twelve predetermined byte positions in VFIP are identified and used to trigger a DTR in each of the twelve Trellis coders in all of the exciters in the SFN. The initialization occurs as soon as each of these deterministically assigned bytes first enter its designated Trellis coder. More particularly, all Trellis coders are synchronized after the first four (4) segments of the VSB Data Frame without any need for any syntax in VFIP itself. Additional syntax, described in more detail below, can be added to control the emission timing and other auxiliary transmitter functions. Thus, by using emission multiplexer **504** (or standard multiplexer **510** and VFIP inserter **509**) to insert a VFIP, VSB frame synchronization is implicitly signaled. By the time the fourth data segment of a new VSB frame is transmitted, all Trellis coders in all exciters will be deterministically reset to a common zero state. Coherent symbols will be produced by all transmitters in SFN.

FIG. 8 is a more detailed block diagram of an ATSC **52** segment continuous convolutional data interleaver. As shown, the interleaver is illustrated as shift registers which permute the symbols in the input signal, where the shift registers (except for the first one) cause a delay. FIG. 9 depicts how the interleaved data is fed to the Trellis coders (#0 through #11). The A/53 defines a deterministic starting point at the beginning of the first data segment of each data field. Based on this starting point and the beforehand knowledge of how byte data interleaver **106** will process a data stream, stuff bytes in a VFIP are pre-calculated and inserted in the correct byte positions to feed a respective one of the twelve Trellis coders. As each designated stuff byte enters a target Trellis coder, the DTR will be triggered.

FIG. 10 shows a memory map of the ATSC **52** segment continuous convolution data interleaver. As illustrated in FIG. 8, bytes are clocked in as illustrated by the commutator on left (i.e., from the Reed-Solomon encoder **104** output), and bytes are clocked out as illustrated by the commutator on the right from left to right (i.e., from the byte data interleaver **106** memory) and sent to the following stages of twelve (12) Trellis coders. As explained above, a Data Field Sync (DFS) is inserted later by the sync insertion unit **110** in the process by exciter **512**. The DFS temporal position is shown in the mapping as a horizontal line across middle of diagram depicted in the mapping shown in FIG. 10 to aid in the understanding of the present invention. In particular, FIG. 10 shows the insertion of a DFS (with no PN63 inversion) in response to a VFIP in the last packet slot (i.e., the **623rd** packet) of the previous data frame.

The diagonal arrows in FIG. 10 show the positions assumed by bytes of the VFIP in the interleaver. As shown, a temporal dispersion of packets across VSB frame boundaries exists. Three of the VFIP bytes (**51,103,153**) reside in the last 52 segment group before the end of the previous frame (Frame n). The remaining data (bytes) are in the first 52 segments of current (Frame n+1). The (4) bytes marked on

each of the three diagonal sections (i.e., the VFIP bytes **52-55, 104-107, 156-159** or "stuff bytes") will be delivered deterministically to each of the (12) Trellis coders numbered 5, 2, B, 8; 9, 6, 3, C; 1, A, 7, 4 (hex), respectively, when they exit the interleaver memory. This allows a deterministic trellis reset (DTR) to occur using each of the designated stuff bytes. Thus, a DTR occurs on processing of stuff bytes in a VFIP, and without affecting or occurring on packets carrying content (Video, Audio, Data). The VFIP Bytes **52-55, 104-107, 156-159** also are shown in FIG. 7 and in FIG. 11 ("Reserved stuff bytes DTR").

By knowing with certainty which VFIP bytes in an interleaved VFIP will pass through the Trellis coders, the stuff bytes can be used to trigger a Trellis reset (DTR) in all of the exciters in the SFN. More particularly, when each one of these (12) stuff bytes first enter its respective Trellis coders, it will cause the Trellis coder to initialize to a predetermined state. This will occur in a serial fashion over four (4) segments and effectively synchronizes all (12) Trellis coders in all exciters **512** in a deterministic fashion. Advantageously, the deterministic Trellis coder reset is thus implemented in exciter **512** such that it adheres to the normal Trellis coder trajectories of a four state Trellis coder. This permits well known switch combinational logic to be used to achieve a common state.

A parity error will occur on every VFIP by the action of the DTR on the twelve designated stuff bytes; this is accepted and will not affect packets carrying normal content. As described above, the twelve Trellis Encoders in each exciter **512** will be reset over the first four segments (0,1,2,3) of Frame N+1 using the stuff bytes. More particularly, each stuff byte used for DTR will cause a deterministic (1) byte error in the RS decoder when VFIP is received. The RS encoding in A/53 allows for correction of up to 10 byte errors per packet. The twelve stuff bytes when DTR is performed will exceed this correction range by two bytes and will generate packet error in RS Decoder. An ATSC receiver ignores a packet error on a VFIP because the VFIP is a reserved PID value defined for use as an operational and maintenance packet (i.e., no content is carried within a VFIP). In particular, ATSC receivers demultiplex based on the PID value and ignore reserved packets (e.g., PID=0x1FFA) known not to be of any use to it. ATSC receivers also will ignore a packet if a parity byte error flag has been set in the header of that packet by the RS decoder in an ATSC receiver.

Referring to FIG. 11, another field in the VFIP is a 20 Byte RS parity field, VFIP_FEC, this additional outer RS coding provides byte errors correction (e.g., 10 byte error corrections) to protect the VFIP from possible errors introduced during transmission. This protects against errors on the distribution network link to the transmitters, and also permits special automated test and measurement equipment in the field to recover the payload of VFIP for network test and monitoring purposes. It should be understood that any type of correction coding that can provide the ability to detect and correct errors may be used instead of RS encoding and still be within the scope of the invention. In addition, the error-correction coding can be performed in the emission multiplexer **504** or by the VFIP inserter **509**, depending on the transport stream emitter configuration used.

The remaining unused space in VFIP is used for syntax for the timing and control of the SFN. The VFIP period is controlled by a field in the VFIP called the periodic_value. Setting this flag to high causes the VFIP to be inserted on a periodic_value field periodic basis. In particular, a value in a periodic_value field indicates the number of frames between insertions of VFIP. For example, a value of 20 would indicate a VFIP packet will be inserted by emission multiplexer **504**

every 20 data frames, i.e., approximately once per second. Instead of making the VFIP delay periodic, a VFIP can be inserted at any multiple of a data frame in step with cadence counter described above.

The distribution network **506** to the transmission system **502** inherently has a delay due to the type of distribution network, e.g., fiber, microwave, satellite and the like, and other connections, e.g., coax cables and the like. Timing syntax within the VFIP allows each RF transmitter **502** to calculate an overall delay to compensate for these delays and provide tight temporal control of the emission time of the coherent symbols from the antennas of all transmitters in a SFN and thus provides control over the delay spread seen by receiver.

FIG. **12** depicts SFN synchronization timelines showing the timing syntax and semantics for an ATSC SFN in accordance with an embodiment of the present invention. Referring to FIGS. **11** and **12**, `sync_time_stamp` (STS) and `max_delay` (MD or Maximum Delay) fields in the VFIP are used to provide compensation to all of the transmitters in the SFN for the unequal or time varying delay in distribution network **506**. In addition, the `tx_time_offset` (OD) field is used to fine tune or adjust timing of a particular RF transmitter **502** in the SFN.

As described above, the transport stream emitter (**514** and **508**) and all the exciters **512** in the SFN (i.e., all nodes) use a GPS timebase **505** to receive a frequency 10 MHz and a temporal 1PPS reference. A 24 bit binary counter within the transport stream emitters keeps track of the reference clock based on the GPS timebase **505**. This 24 bit counter is also available at all exciters **512**. The 1PPS signal from the GPS timebase **505** is used to reset a 24 bit binary counter to zero on rising edge of 1PPS. The counter is clocked by a 10 MHz frequency reference and counts from 0-9999999 in one second, then resets to zero. Each clock tick and count advance is 100 nano seconds. This 24 bit binary counter technique is available in all nodes of the network and forms the basis for all time stamps used in the SFN.

The `sync_time_stamp` (STS) field in a VFIP is a 24 bit field containing the value the 24-bit counter will assume in emission multiplexer **504** observed at the instant VFIP leaves the emission multiplexer **504** to distribution network **506**. In the alternative configuration, the `sync_time_stamp` (STS) field in a VFIP is a 24 bit field containing the value the 24 bit binary counter will assume in the VFIP inserter **509** observed at the instant VFIP leaves the VFIP inserter **509** to distribution network **506**. Similar 24-bit counters are included in the RF transmitter systems **502**. All counters at all the nodes in the network are synchronized to the same GPS 10 MHz and 1PPS, allowing their counts to be synchronized. Each increment of the counter is 100 nano seconds. This known value is used in each RF transmitter **502** to calculate a transit delay (TD) through its respective distribution network (e.g., Satellite, Microwave, Fiber, and the like). More particularly, as described above, the STS value is the time that the VFIP left emission multiplexer **504** and entered distribution network **506**. The STS value is compared to an observation of the current count of the 24 bit counter in exciter **512** the instant the VFIP is received to determine the TD of how long (i.e., how many 100 nano second increments) the VFIP packet took to arrive through the distribution network **506**. FIG. **12** shows graphically the release of VFIP into distribution network **506** and the instant VFIP arrives at a transmitter **502** as a function of time.

The `maximum_delay` field in the VFIP (corresponding to Maximum Delay or MD in FIG. **12**) is a 24-bit value containing a predetermined delay value established based on a quantitative review of the delays of all distribution paths to all

digital RF transmitters in the SFN. Particularly, the `maximum_delay` value entered is calculated to be greater than the delay of the longest path in distribution network **506**. By selecting an MD value larger than the maximum transit delay expected through all distribution paths, an input buffer can be calculated and setup in each exciter **512** to delay the incoming TS packets such that they are transmitted from all transmitters simultaneously regardless of the transit time of a packet through distribution network **506**. This is shown in FIG. **12** as the Reference Emission Time. The reference emission time is the start of segment sync in DFS (without PN63 inversion) immediately following VFIP.

The `tx_time_offset` (OD) field is a 16 bit value addressed to each transmitter that contains an optional delay value used to fine tune the delay spread of particular transmitters to optimize the network.

Thus, based on the calculation of how long the VFIP packet took to arrive using in part the `sync_time_stamp` (STS), the `maximum_delay` (MD) value and a `tx_offset_delay` (OD), an RF transmitter **502** can set its input delay buffer, TX Delay. Accordingly, the value of the delay buffer in each exciter **512**, TX Delay, is shown in FIG. **12** and defined by Equation (1) as follows:

$$\text{TX Delay} = \text{STS} + \text{MD} + \text{OD} - \text{TD} \quad (1)$$

Thus, the TX delay for each exciter in the SFN **500** is independently calculated. Each RF transmitter **502**, in turn, uses the delay global values (e.g., STS, MD) to establish the reference emission time. The individually addressed OD allows fine control of the emission time of the coherent symbols from all the antennas of all transmitters in a SFN and hence will control the delay spread seen by ATSC receiver. A local value (e.g., 16 bit value, not shown) also can be entered at each site to compensate for the delay calculated through the transmitters, output filters and transmission line length feeding the antenna. This value is subtracted from MD for a particular transmitter to obtain fine resolution on emission time from the antenna which is the reference or demarcation point in an SFN system (i.e., the point at which the RF signal guided wave transitions into free space).

FIG. **13** depicts a single frequency network environment including mobile, indoor, handheld, and fixed services modes in accordance with the present invention. More particularly, mobile **1310**, indoor **1308**, handheld **1306**, and fixed **1312** services for receiving data from a single frequency network, are shown. These services can receive transmissions from different locations, such as transmitter **1302**, single frequency network transmission system **1304** and a smaller building transmitter **1314**. All of the aforementioned services can benefit from a training sequence in accordance with the present invention as will now be described in more detail.

Referring to FIGS. **14-18**, another aspect of the present invention, is shown. The deterministic nature of the interleaver is further utilized to provide a way in which to feed a predetermined training sequence into a digital signal such that as the convolutional interleaver (e.g., FIG. **1**, block **106**) of an exciter **512** processes the digital signal, the interleaver output signal includes a predetermined stream of symbols including the training sequence at known locations within a data stream. The training sequence is referred to herein as a virtual enhanced training sequence ("VETS").

As explained above, initially the immediate state of a Trellis coder is not known because it is dependent on the values of the Trellis coder's preceding data. To provide the opportunity to transmit a known sequence of training symbols, first the Trellis coders in all of the exciters **512** in an SFN **500** must be placed into a known state. This is accomplished by perform-

ing a deterministic Trellis reset (“DTR”) as described above, except instead of creating a VFIP with stuff bytes, bits within a VETS are set to perform the DTR. Since the Trellis coders can be deterministically reset, a known training sequence can be generated and inserted into the remaining portions of a VETS based on a priori knowledge of the location of the interleaved data packets at the output of byte data interleaver **106** (FIG. 1).

A receiver which has prestored a sequence corresponding to a VETS uses the prestored sequence and the continuous stream of symbols with the VETS to initialize the receiver (e.g., by determining initial filter tap coefficients as described above). The particular sequence of symbols and algorithm used by the receiver to process the VETS is a design choice. Thus advantageously, a more robust training sequence can be created which will allow a receiver to initialize more quickly.

A VETS does not affect the functionality of legacy receivers because the training sequence data are inserted in locations within a digital signal that do not interfere with the ATSC A/53 standard. Legacy receivers that cannot process a VETS simply ignore it.

FIG. 14 depicts the output of an ATSC **52** segment continuous convolutional byte interleaver including an interleaved training sequence **1400** in accordance with an embodiment of the present invention. As shown in FIG. 14, the training sequence **1400** includes four portions: **1400a**, **1400b**, **1400c** and **1400d**. In the example shown in FIG. 14, the present invention provides a VETS having a stream of 3100 known symbols. The PID of each packet used to form a VETS identifies each packet as a private data packet (e.g., private MPEG data packets). In this example, 54 private data packets are used to create the 3100 symbol VETS. As shown, every data segment begins with a segment sync of 4 symbols as per the A/53 standard.

A VETS is inserted into a digital signal as follows. Initially, a container of 54 private data packets with known byte positions are created by emission multiplexer **504** (or standard multiplexer **510** and VFIP inserter **509**). These packets are created at the studio as private data so that legacy receivers which cannot process a VETS will ignore these packets. As described above, after an RF transmitter **208** receives the incoming data packets of interspersed video, audio, and ancillary data, a data randomizer **102** (FIG. 1) randomizes the data to produce a flat, noise-like spectrum. After the 54 private data packets are processed by randomizer **102**, the randomized data inside the data packets is discarded by exciter **512** by, for example, overwriting it with VETS data stored in exciter’s **512** memory (not shown).

With the knowledge of the output of the ATSC interleaver **106**, twelve predetermined byte positions in VETS are identified and used to trigger a DTR in each of the twelve Trellis coders in all the exciters **512** in SFN **500**. These twelve bytes are depicted as DTR+VETS bytes **1402**. The initialization occurs as soon as particular bits set within the DTR+VETS bytes **1402** first enter its designated Trellis coder. Once the Trellis coders are driven to a known state (e.g., zero) then a precalculated bit sequence can be generated with the knowledge of the starting state of the Trellis coders.

The following is a description of an exemplary VETS. The first group of 604 symbols **1400a** include twelve bytes referred to as DTR+VETS bytes **1402**. The first four bits of the twelve DTR+VETS bytes **1402** are used to place the Trellis coders (e.g., twelve Trellis coders) into a known state. The remaining four bits of each of the twelve bytes are a portion of the training sequence. The remainder of the 604 symbols includes a portion of the training sequence. The other three portions of a VETS **1400** are three segments of 828

symbols including the remaining portion of the training sequence **1400b**, **1400c** and **1400d**.

Also shown in FIG. 14 is a data field sync (DFS) **1401** with no PN 63 inversion. As discussed above this allows a receiver to recognize the alternate data fields which define a frame. In Data Field Sync #1 all three PN63 sequences are in the same phase and in Data Field Sync #2 the middle PN63 sequence is inverted and the other two have the same phase. The exciter **512** inserts a DFS with no PN63 inversion directly after the last bit of the VFIP packet and then continues with normal VSB frame construction starting with next TS packet (0) as first data-segment of the next VSB frame.

FIG. 15 depicts a table corresponding to the packets and byte positions used to create a VETS in accordance with an embodiment of the present invention. The actual known data will be inserted into these positions after randomizer **102**. More particularly, after the 54 container packets have been processed by randomizer **102**, the data within those 54 container packets will be replaced with predetermined data including the VETS in accordance with the identified bytes within the corresponding packets as indicated in the exemplary table shown in FIG. 15.

FIG. 16 depicts the input to the ATSC **52** segment continuous convolutional byte interleaver including a VETS **1400**. As shown in FIG. 16 DTR+VETS **1402** are pre-calculated and inserted in predetermined byte positions. Particularly, 12 stuff bits are inserted in locations that will feed a respective one of the twelve Trellis coders. As each designated stuff byte enters a target Trellis coder, the DTR will be triggered. Also shown is the a priori placement of data including the remaining portions of the training sequence **1400a**, **1400b**, **1400c** and **1400d**. Thus, as a VETS is processed by the convolutional byte interleaver, the training sequence will be communicated to a receiver at predetermined times, particularly as a predetermined stream of symbols.

FIG. 17 depicts the output of an ATSC **52** segment continuous convolutional byte interleaver including an interleaved training sequence **1400** as well as VFIP deterministic trellis reset (DTR) bytes marked on three diagonal sections in accordance with an embodiment of the present invention. As described above with respect to FIG. 10, the (4) DTR bytes marked on each of the three diagonal sections (i.e., the VFIP bytes **52-55**, **104-107**, **156-159** or “stuff bytes”) will be delivered deterministically to each of the (12) Trellis coders numbered 5, 2, B, 8; 9, 6, 3, C; 1, A, 7, 4 (hex), respectively, when they exit the interleaver memory. VFIP **1600** shown in FIG. 17 is an example of one of the 54 private data packets being used to carry both DTR and VETS data. As shown, a VETS **1400** does not interfere with the VFIP DTR bytes used for resetting Trellis coders. This is accomplished, for example, by generating a 188 byte VFIP **1600** with 4-byte portions of a VETS **1400** strategically inserted into a reserved space in the VFIP **1600**, as shown in FIG. 17. Once a packet (e.g., a VFIP **1600**) reaches exciter **512**, its sync byte (i.e., hex **47**) is removed resulting in a 187 byte packet. This accounts for the one byte shift in the VFIP data (e.g., DTR **53-56** to **52-55**). Parity is then computed and the 187 byte packet and its parity (207 bytes) form a data segment which, in turn, is interleaved. The interleaved data segments are then communicated to receiving devices by RF transmitter system **502** as described above. As shown, the DTR+VETS bytes **1402** are inserted such that they will not interfere with a VFIP as well.

FIG. 18 depicts the input to the ATSC **52** segment continuous convolutional byte interleaver including the interleaved training sequence data and deterministic trellis reset (DTR) bytes in accordance with an embodiment of the present invention. As shown, the DTR bytes **1700**, **1702** and **1704** corre-

15

sponding to bytes **53-56, 105-108** and **157-160** in the VFIP of FIG. **17** and the VETS, including DTR+VETS bytes **1402**, do not interfere with one another.

While various embodiments of the present invention have been described above, it should be understood that they have been presented by way of example, and not limitation. It will be apparent to persons skilled in the relevant art(s) that various changes in form and detail can be made therein without departing from the spirit and scope of the present invention. Thus, the present invention should not be limited by any of the above described exemplary embodiments, but should be defined only in accordance with the following claims and their equivalents.

In addition, it should be understood that the figures illustrated in the attachments, which highlight the functionality and advantages of the present invention, are presented for example purposes only. The architecture of the present invention is sufficiently flexible and configurable, such that it may be utilized in ways other than that shown in the accompanying figures.

Further, the purpose of the foregoing Abstract is to enable the U.S. Patent and Trademark Office and the public generally, and especially the scientists, engineers and practitioners in the art who are not familiar with patent or legal terms or phraseology, to determine quickly from a cursory inspection the nature and essence of the technical disclosure of the application. The Abstract is not intended to be limiting as to the scope of the present invention in any way. It is also to be understood that the steps and processes recited in the claims need not be performed in the order presented.

What is claimed is:

1. A method for communicating a training sequence for initializing an equalizer in a digital receiver, comprising the steps of:

receiving a digital signal containing data to be broadcast from a digital RF transmitter;

inserting training sequence data into the digital signal at predetermined byte locations based on a mapping of an ATSC (Advanced Television Systems Committee) A/53 data interleaver such that a continuous predetermined sequence of symbols is generated from the training sequence data and communicated to the digital receiver at known locations within a broadcast ATSC A/53 VSB (vestigial sideband) data frame; and

inserting a plurality of stuff bytes into the digital signal for deterministically initializing a plurality of ATSC A/53 Trellis coders in an exciter of the digital RF transmitter to a known state,

wherein the plurality of stuff bytes are inserted prior to encoding the training sequence data into the continuous predetermined sequence of symbols by the plurality of ATSC A/53 Trellis coders, and

wherein a first set of bits of each one of the plurality of stuff bytes are used to deterministically reset a respective first set of the plurality of ATSC A/53 Trellis coders, and a second set of bits of each one of the plurality of stuff bytes include a portion of the training sequence data.

2. The method of claim **1**, further comprising: convolutionally interleaving the digital signal.

3. The method of claim **1**, wherein the digital signal further contains an identifier identifying the packet as a private data packet.

4. The method of claim **1**, further comprising:

generating a plurality of container packets to contain the training sequence data, wherein the plurality of container packets are located at a plurality of predetermined positions within the digital signal.

16

5. A receiver operable to receive the continuous predetermined sequence of symbols according to claim **1**.

6. The method according to claim **1**, wherein the continuous predetermined sequence of symbols is longer than one segment of the ATSC A/53 VSB data frame.

7. The method according to claim **1**, wherein the continuous predetermined sequence of training symbols corresponds to a prestored sequence of symbols stored in the digital receiver.

8. The method according to claim **1**, wherein the training sequences are stored in a predetermined number of container packets.

9. The method according to claim **8**, wherein the container packets are private data packets.

10. A method for communicating a training sequence for initializing an equalizer in a digital receiver, comprising the steps of:

receiving a digital signal containing data to be broadcast from a digital RF transmitter;

inserting training sequence data into the digital signal at predetermined byte locations based on a mapping of an ATSC (Advanced Television Systems Committee) A/53 data interleaver such that a continuous predetermined sequence of symbols is generated from the training sequence data and communicated to the digital receiver at known locations within a broadcast ATSC A/53 VSB (vestigial sideband) data frame; and

inserting an initialization packet into the digital signal, the initialization packet containing a plurality of stuff bytes for deterministically initializing a plurality of ATSC A/53 Trellis coders in the exciter and having a reserved space for a portion of the training sequence data.

11. The method of claim **10**, further comprising:

synchronizing a plurality of ATSC A/53 VSB data frames based on an arrival of the initialization packet.

12. An apparatus for communicating a training sequence for initializing an equalizer in a digital receiver, comprising:

a receiver operable to receive a digital signal containing data to be broadcast from a digital RF transmitter; and

a packet inserter operable to insert training sequence data into the digital signal at predetermined byte locations based on a mapping of an ATSC (Advanced Television Systems Committee) A/53 data interleaver such that a continuous predetermined sequence of training symbols is generated from the training sequence data and communicated to the digital receiver at known locations within a broadcast ATSC A/53 VSB (vestigial sideband) data frame and insert a plurality of stuff bytes into the digital signal for deterministically initializing a plurality of ATSC Trellis coders in an exciter of the digital RF transmitter to a known state,

wherein the plurality of stuff bytes are inserted prior to encoding the training sequence data into the continuous predetermined sequence of symbols by the plurality of ATSC A/53 Trellis coders, and

wherein a first set of bits of each one of the plurality of stuff bytes are used to deterministically reset a respective first set of the plurality of ATSC A/53 Trellis coders, and a second set of bits of each one of the plurality of stuff bytes include a portion of the training sequence data.

13. The apparatus of claim **12**,

wherein the ATSC A/53 interleaver is operable to convolutionally interleave the digital signal.

14. The apparatus of claim **12**, wherein the digital signal further contains an identifier identifying the packet as a private data packet.

17

15. The apparatus of claim 12, wherein the packet inserter is further operable to replace a content of a plurality of container packets with the training sequence data, wherein the plurality of container packets are located at a plurality of predetermined positions within the digital signal.

16. A receiver operable to receive the continuous predetermined sequence of symbols according to claim 12.

17. The apparatus according to claim 12, wherein the continuous predetermined sequence of symbols is longer than one segment of the ATSC A/53 VSB data frame.

18. The apparatus according to claim 12, wherein the continuous predetermined sequence of training symbols corresponds to a prestored sequence of symbols stored in the digital receiver.

19. The apparatus according to claim 12, wherein the training sequence data are stored in a predetermined number of container packets.

20. The apparatus according to claim 19, wherein the container packets are private data packets.

21. An apparatus for communicating a training sequence for initializing an equalizer in a digital receiver, comprising: a receiver operable to receive a digital signal containing data to be broadcast from a digital RF transmitter; and a packet inserter operable to insert training sequence data into the digital signal at predetermined byte locations based on a mapping of an ATSC (Advanced Television Systems Committee) A/53 data interleaver such that a continuous predetermined sequence of training symbols is generated from the training sequence data and communicated to the digital receiver at known locations within a broadcast ATSC A/53 VSB (vestigial sideband) data frame and insert an initialization packet into the digital signal, the initialization packet containing a plurality of stuff bytes for deterministically initializing a plurality of ATSC A/53 Trellis coders in the digital RF transmitter and having a reserved space for a portion of the training sequence data.

22. The apparatus of claim 21, wherein a plurality of ATSC A/53 VSB data frames are synchronized based on an arrival of the initialization packet.

23. A computer program product comprising a non-transitory computer usable medium having control logic stored therein for causing a computer to communicate a training sequence for initializing an equalizer in a digital receiver, said control logic comprising:

computer readable program code means for causing the computer to receive a digital signal containing data to be broadcast from a digital RF transmitter;

computer readable program code means for causing the computer to insert training sequence data into the digital signal at predetermined byte locations based on a mapping of an ATSC (Advanced Television Systems Committee) A/53 data interleaver such that a continuous predetermined sequence of training symbols is generated from the training sequence data and communicated to the digital receiver at known locations within a broadcast ATSC A/53 VSB (vestigial sideband) data frame; and

computer readable program code means for causing the computer to insert a plurality of stuff bytes into the digital signal for deterministically initializing a plurality of ATSC A/53 Trellis coders in an exciter of the digital RF transmitter to a known state,

wherein the plurality of stuff bytes are inserted prior to encoding the training sequence data into the continuous predetermined sequence of symbols by the plurality of ATSC A/53 Trellis coders, and

18

wherein a first set of bits of each one of the plurality of stuff bytes are used to deterministically reset a respective first set of the plurality of ATSC A/53 Trellis coders, and a second set of bits of each one of the plurality of stuff bytes include a portion of the training sequence data.

24. The computer program product of claim 23, further comprising:

computer readable program code means for causing the computer to convolutionally interleave the digital signal.

25. The computer program product of claim 23, wherein the digital signal further contains an identifier identifying the packet as a private data packet.

26. The computer program product of claim 23, further comprising:

computer readable program code means for causing the computer to generate a plurality of container packets to contain the training sequence data, wherein the plurality of container packets are located at a plurality of predetermined positions within the digital signal.

27. The computer program product according to claim 23, wherein the continuous predetermined sequence of symbols is longer than one segment of the ATSC A/53 VSB data frame.

28. The computer program product according to claim 23, wherein the continuous predetermined sequence of training symbols corresponds to a prestored sequence of symbols stored in the digital receiver.

29. The computer program product according to claim 23, wherein the training sequence data are stored in a predetermined number of container packets.

30. The computer program product according to claim 29, wherein the container packets are private data packets.

31. A computer program product comprising a non-transitory computer usable medium having control logic stored therein for causing a computer to process the continuous predetermined sequence of symbols in accordance with claim 23.

32. A computer program product comprising a non-transitory computer usable medium having control logic stored therein for causing a computer to communicate a training sequence for initializing an equalizer in a digital receiver, said control logic comprising:

computer readable program code means for causing the computer to receive a digital signal containing data to be broadcast from a digital RF transmitter;

computer readable program code means for causing the computer to insert training sequence data into the digital signal at predetermined byte locations based on a mapping of an ATSC (Advanced Television Systems Committee) A/53 data interleaver such that a continuous predetermined sequence of training symbols is generated from the training sequence data and communicated to the digital receiver at known locations within a broadcast ATSC A/53 VSB (vestigial sideband) data frame; and

computer readable program code means for causing the computer to insert an initialization packet into the digital signal, the initialization packet containing a plurality of stuff bytes for deterministically initializing a plurality of ATSC A/53 Trellis coders in the digital RF transmitter and having a reserved space for a portion of the training sequence data.

33. The computer program product of claim 32, further comprising:

computer readable program code means for causing the computer to synchronize a plurality of ATSC A/53 VSB data frames based on an arrival of the initialization packet.

34. A system for communicating a training sequence for initializing an equalizer in a digital receiver, comprising:

a multiplexer operable to generate a plurality of container packets to contain training sequence data, wherein the plurality of container packets are located at a plurality of predetermined positions within a digital signal; and
 5 an exciter operable to receive the digital signal containing data to be broadcast from a digital RF transmitter and insert the training sequence data into the container packets at predetermined byte locations based on a mapping of an ATSC (Advanced Television Systems Committee) data interleaver such that a continuous predetermined sequence of symbols is generated from the training sequence and communicated to the digital receiver at known locations within a broadcast ATSC A/53 VSB (vestigial sideband) data frame and insert a plurality of
 10 stuff bytes into the digital signal for deterministically initializing a plurality of ATSC A/53 Trellis coders in the exciter to a known state,

wherein the plurality of stuff bytes are inserted prior to encoding the training sequence data into the continuous predetermined sequence of symbols by the plurality of ATSC A/53 Trellis coders, and
 20 wherein a first set of bits of each one of the plurality of stuff bytes are used to deterministically reset a respective first set of the plurality of ATSC A/53 Trellis coders, and a second set of bits of each one of the plurality of stuff bytes include a portion of the training sequence data.

35. The system according to claim 34, wherein the continuous predetermined sequence of symbols is longer than one segment of the ATSC A/53 VSB data frame.
 30

36. The system according to claim 34, wherein the continuous predetermined sequence of training symbols corresponds to a prestored sequence of symbols stored in the digital receiver.
 35

37. The system according to claim 34, wherein the training sequences are stored in a predetermined number of container packets.

38. A system for communicating a training sequence for initializing an equalizer in a digital receiver, comprising:
 40

a multiplexer operable to generate a plurality of container packets to contain training sequence data, wherein the plurality of container packets are located at a plurality of predetermined positions within a digital signal, and insert an initialization packet into the digital signal, the initialization packet containing a plurality of stuff bytes for deterministically initializing a plurality of ATSC A/53 Trellis coders in the digital RF transmitter and having a reserved space for a portion of the training sequence data; and
 45

an exciter operable to receive the digital signal containing data to be broadcast from a digital RF transmitter and insert the training sequence data into the container packets at predetermined byte locations based on a mapping of an ATSC (Advanced Television Systems Committee) data interleaver such that a continuous predetermined sequence of symbols is generated from the training sequence and communicated to the digital receiver at known locations within a broadcast ATSC A/53 VSB (vestigial sideband) data frame.
 50

39. The system of claim 38, wherein a plurality of ATSC A/53 VSB data frames are synchronized based on an arrival of the initialization packet.

40. A method for communicating a training sequence for initializing an equalizer in a digital receiver, comprising the steps of:
 65

receiving a digital signal containing data to be broadcast from a digital RF transmitter;

inserting training sequence data into the digital signal at predetermined byte locations based on a mapping of an ATSC (Advanced Television Systems Committee) A/53 data interleaver such that a continuous predetermined sequence of symbols is generated from the training sequence data and communicated to the digital receiver at known locations within a broadcast ATSC A/53 VSB (vestigial sideband) data frame; and
 5

inserting a plurality of stuff bytes into the digital signal for deterministically initializing a plurality of ATSC A/53 Trellis coders in an exciter of the digital RF transmitter to a known state,
 10

wherein the plurality of stuff bytes are inserted prior to encoding the training sequence data into the continuous predetermined sequence of symbols by the plurality of ATSC A/53 Trellis coders, and
 15

wherein four bits of each one of the plurality of stuff bytes are used to deterministically reset the plurality of ATSC A/53 Trellis coders, and another four bits of each one of the plurality of stuff bytes include a portion of the training sequence data.

41. An apparatus for communicating a training sequence for initializing an equalizer in a digital receiver, comprising:
 25

a receiver operable to receive a digital signal containing data to be broadcast from a digital RF transmitter;

a packet inserter operable to insert training sequence data into the digital signal at predetermined byte locations based on a mapping of an ATSC (Advanced Television Systems Committee) A/53 data interleaver such that a continuous predetermined sequence of training symbols is generated from the training sequence data and communicated to the digital receiver at known locations within a broadcast ATSC A/53 VSB (vestigial sideband) data frame, and insert a plurality of stuff bytes into the digital signal for deterministically initializing a plurality of ATSC Trellis coders in an exciter of the digital RF transmitter to a known state,
 30

wherein the plurality of stuff bytes are inserted prior to encoding the training sequence data into the continuous predetermined sequence of symbols by the plurality of ATSC A/53 Trellis coders, and
 35

wherein four bits of each one of the plurality of stuff bytes are used to deterministically reset the plurality of ATSC A/53 Trellis coders, and another four bits of each one of the plurality of stuff bytes include a portion of the training sequence data.

42. A computer program product comprising a non-transitory computer usable medium having control logic stored therein for causing a computer to communicate a training sequence for initializing an equalizer in a digital receiver, said control logic comprising:
 40

computer readable program code means for causing the computer to receive a digital signal containing data to be broadcast from a digital RF transmitter;

computer readable program code means for causing the computer to insert training sequence data into the digital signal at predetermined byte locations based on a mapping of an ATSC (Advanced Television Systems Committee) A/53 data interleaver such that a continuous predetermined sequence of training symbols is generated from the training sequence data and communicated to the digital receiver at known locations within a broadcast ATSC A/53 VSB (vestigial sideband) data frame; and
 45

21

computer readable program code means for causing the computer to insert a plurality of stuff bytes into the digital signal for deterministically initializing a plurality of ATSC A/53 Trellis coders in an exciter of the digital RF transmitter to a known state, 5

wherein the plurality of stuff bytes are inserted prior to encoding the training sequence data into the continuous predetermined sequence of symbols by the plurality of ATSC A/53 Trellis coders, and 10

wherein four bits of each one of the plurality of stuff bytes are used to deterministically reset the plurality of ATSC A/53 Trellis coders, and another four bits of each one of the plurality of stuff bytes include a portion of the training sequence data. 15

43. The system according to claim 42, wherein the container packets are private data packets.

44. A system for communicating a training sequence for initializing an equalizer in a digital receiver, comprising: 20

a multiplexer operable to generate a plurality of container packets to contain training sequence data, wherein the plurality of container packets are located at a plurality of predetermined positions within a digital signal;

22

an exciter operable to receive the digital signal containing data to be broadcast from a digital RF transmitter and insert the training sequence data into the container packets at predetermined byte locations based on a mapping of an ATSC (Advanced Television Systems Committee) data interleaver such that a continuous predetermined sequence of symbols is generated from the training sequence and communicated to the digital receiver at known locations within a broadcast ATSC A/53 VSB (vestigial sideband) data frame and insert a plurality of stuff bytes into the digital signal for deterministically initializing a plurality of ATSC A/53 Trellis coders in the exciter to a known state,

wherein the plurality of stuff bytes are inserted prior to encoding the training sequence data into the continuous predetermined sequence of symbols by the plurality of ATSC A/53 Trellis coders, and

wherein four bits of each one of the plurality of stuff bytes are used to deterministically reset the plurality of ATSC A/53 Trellis coders, and another four bits of each one of the plurality of stuff bytes include a portion of the training sequence data.

* * * * *