

May 2, 1933.

I. HILL

1,906,964

CONTAINER FOR STORING PERISHABLE MERCHANDISE

Filed Aug. 9, 1930

2 Sheets-Sheet 1

Fig. 1.

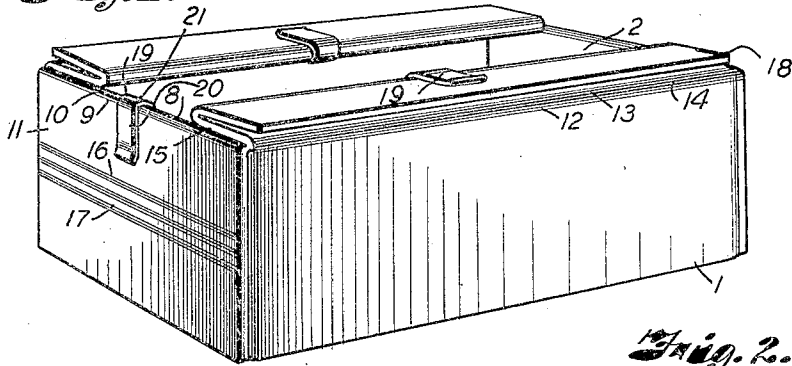

Fig. 2.

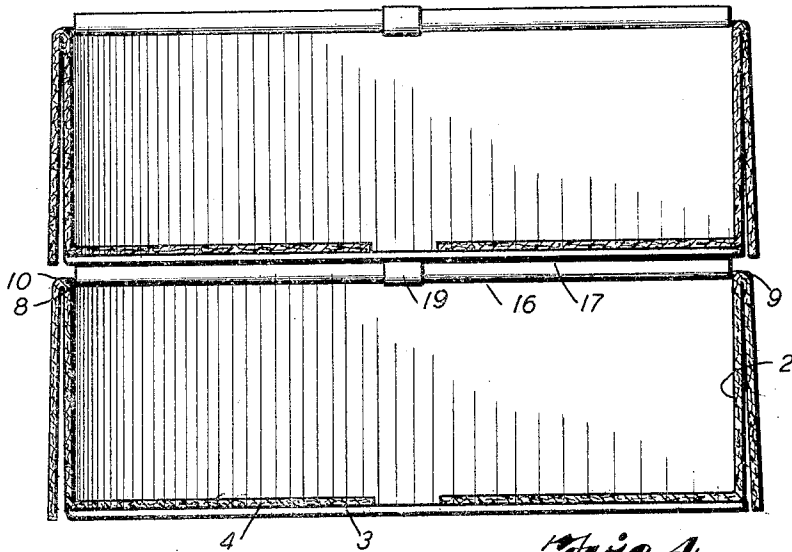

Fig. 3.

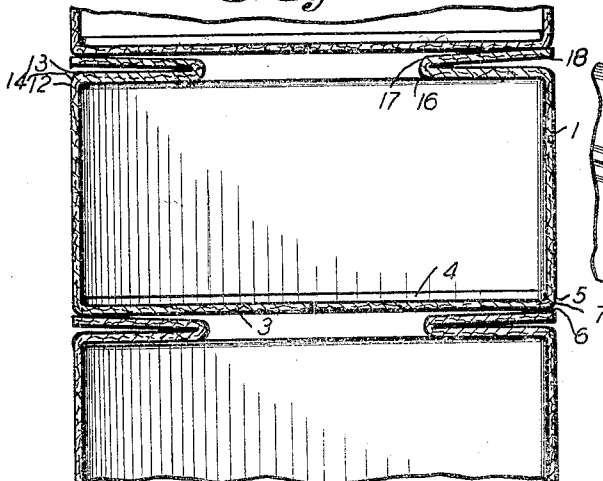
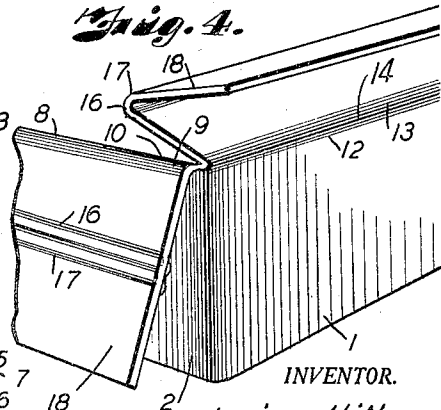

Fig. 4.



INVENTOR.

Irving Hill

BY

Arthur Brown.

ATTORNEY.

May 2, 1933.

I. HILL

1,906,964

CONTAINER FOR STORING PERISHABLE MERCHANDISE

Filed Aug. 9, 1930

2 Sheets-Sheet 2

Fig. 5.

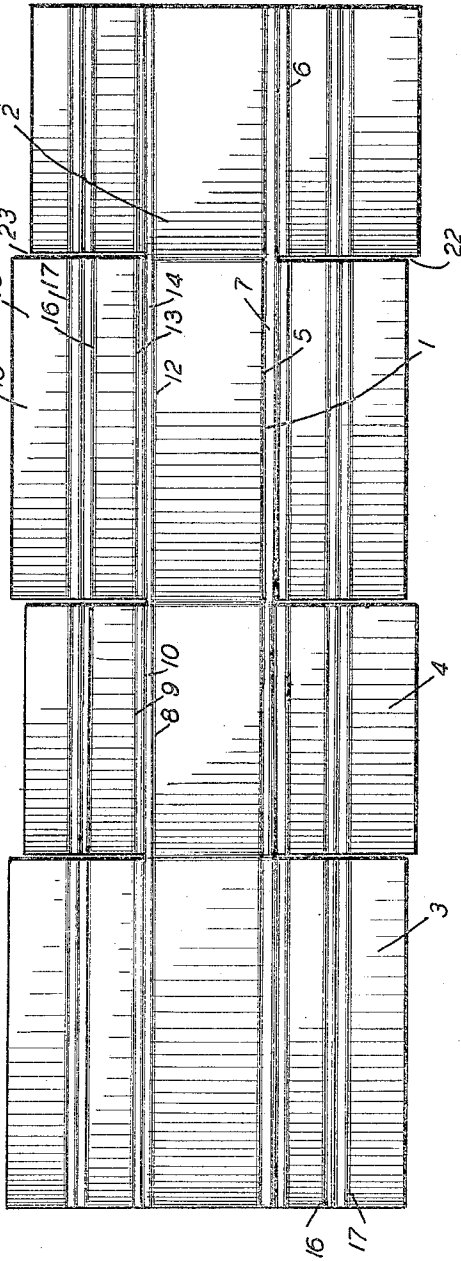

Fig. 6.



INVENTOR.
Irving Hill
BY *Arthur C. Brown*
ATTORNEY.

UNITED STATES PATENT OFFICE

IRVING HILL, OF LAWRENCE, KANSAS, ASSIGNOR, BY MESNE ASSIGNMENTS, TO
THE LAWRENCE PAPER COMPANY, OF LAWRENCE, KANSAS, A CORPORATION OF
KANSAS

CONTAINER FOR STORING PERISHABLE MERCHANDISE

Application filed August 9, 1930. Serial No. 474,097.

My invention relates to boxes and more particularly to containers for storing perishable merchandise, for example poultry, which is intended to be frozen in the packages in which it will be stored or shipped, the boxes ordinarily being closed for piling in a refrigerating room, and thus both reducing the refrigerating effect on the contained poultry and increasing the cost, time and hazards of refrigeration.

The principal objects of my invention therefore, are to increase the efficiency of treatment of packaged products in storage, to provide a box capable of being manipulated to enhance the effect of treatment such as refrigeration, and to reduce the time, cost and hazards of refrigerating contents of boxes.

In accomplishing these and other objects of my invention, I have provided improved details of structure, the preferred forms of which are illustrated in the accompanying drawings, wherein:

Fig. 1 is a perspective view of a box member embodying my invention.

Fig. 2 is a longitudinal vertical section of a pair of boxes arranged in tiers.

Fig. 3 is a fragmentary cross section of a tier of boxes illustrating the supporting function of partly opened cover flange.

Fig. 4 is a detail fragmentary perspective view of a corner of a box illustrating the side and end flaps.

Fig. 5 is a plan view of a blank cut and scored for forming a box therefrom.

Fig. 6 is an elevation of the side edge of the blank.

Referring in detail to the drawings:

1 and 2 designate body walls of a box, comprising in the illustrated example, vertical side and end members preferably integral respectively with flaps 3 and 4 formed on one edge of said members and defined by inner and outer score lines 5 and 6 spaced to provide relatively narrow webs 7 and form flap hinges.

Spaced score lines 8 and 9 producing webs 10 define flaps 11 at the opposite edges of the end members, and score lines 12 and 13 spaced by webs 14 form hinges for flaps 15 at the

edges of the side members opposite to the flaps 3.

In the drawings the flaps 3 and 4 comprise lower edge flaps folded inwardly on the inner score lines 5 to form the bottom of the box, the side and end wall flaps overlapping and being secured together in any suitable manner, for example by stitching.

The extensions forming the flaps 11 on the upper edges of the end walls may be moved hingedly on either the lines 8 or 9 or both, in either direction, to partly cover the open upper end of the box for storage or shipment, or to extend substantially parallel with the end walls outside of the box as illustrated in Figs. 1 and 2.

The end flaps 11 when hinged outwardly on the lines 8 and 9 preferably have substantially the same length as the height of the end walls, the bottom being flaps, are folded on the inner score lines 5, and thus cover the same and are adapted to form reinforcement or stiffening elements for the ends of the box as later described.

The several flaps are provided with longitudinal parallel lines of scoring 16 and 17 preferably applied on each side of the median lines of said flaps to define outer hinged portions or wings 18 adapted to be folded inwardly or outwardly over the inner portions or bodies of the flaps. In the illustrated usage, the wings of the side cover flaps are hingedly adjusted outwardly over the inwardly horizontally arranged cover flap bodies and the outer edge portions of the wings overlie the vertical side walls with the edges of said wings substantially registering with the outer faces of said side walls as illustrated in Fig. 3.

Clips 19 are mounted over the outwardly folded end flaps to engage the inner faces of the end walls and outwardly presented faces of the flaps to retain the outbent flaps in engagement with the end walls and cause the lower edges of said flaps to lie substantially in registry with the lower edges of the side and end walls, as illustrated in Fig. 1.

Clips 19 are also employed to anchor the hinged wings, being applied to the fold edges of the cover flaps to hold the wings in

engagement with the bodies and retain the flaps in adjusted position as illustrated in Figs. 1 and 3 to form an opening in the top of the box and provide support for a superimposed second box.

The clips have resilient arms 20, and body portions or webs 21 adapted to the width of the webs of the flap hinges to permit the clips to be mounted over the relatively wide hinges formed by the spaced score lines, whereby the bodies of the clips may engage the hinges of the flaps.

The entire box is preferably made from a single blank of material such as corrugated fibre board, as illustrated in Fig. 5, wherein the score lines 8 and 9 defining the end flaps are aligned with the score lines 12 and 13 defining the side flaps, and may be applied by continuous operations on longitudinal lines of the blank. The combination of score lines on the cover flaps provide continuous lines similar to the lines 5 and 6. Corresponding score lines on the flaps are also aligned, whereby the blank is formed substantially symmetrically, and the flaps may be employed either as bottom or cover members.

Slits such as 22 and 23 are formed laterally in the blank to separate the bottom and cover end flaps from the bottom and cover side flaps respectively, said slits 22 preferably terminating in the webs between the inner and outer score lines that define the flaps 3 and 4, and the slits 23 passing through the outer score lines 9 and 13 and webs 10 and 14 to the inner score lines 8 and 12. The cover flaps are thus hinged to the side and end walls by the portions of the blank to which said inner score lines are applied, and the flaps may be pivoted on the hinges on either side of the webs upwardly or downwardly irrespective of the direction in which said flaps were hingedly moved with respect to the vertical walls.

In using the invention, boxes containing merchandise may be arranged in partly open position with the end flaps clamped to the end walls and the side flap wings laid back over the flap bodies and clamped thereto. The boxes may then be piled in tiers, the side flaps of a lower box supporting an upper box securely, but in slightly spaced relation with the upper edges of the end walls of the lower box, whereby air may have relatively free access to the boxes.

Boxes stored in the manner indicated will take up relatively little more space than closed boxes, the cover flaps are secured against possible damage and the boxes are materially strengthened for piling in tiers.

Ordinary closed boxes piled in tiers retard desired quick chilling, tending to permit destruction of the bloom on the products, or to create two large crystals within the product frozen, and thus reduce the quality.

The folded flaps illustrated, however, hold the boxes apart enough to permit cold air to circulate to the contents of tiered boxes, thus materially facilitating freezing, and producing a product having improved quality.

Boxes further have particular advantage for packaging perishable products requiring refrigeration, for example, dressed poultry portions such as the breasts of poultry, being pressed by the side cover flaps, whereby the condition and appearance of the packaged goods may be improved due to piling the boxes in storage while the refrigeration of the products is expedited and an improved quality of product is obtained.

The cover flaps may be provided with hinges or creases such as score lines to form folded supports for spacing an upper from a lower box to a greater or less extent.

Poles or the like may be employed with the boxes shown to increase the ventilating space between boxes, though ordinarily the flaps will provide sufficient spacing effect.

What I claim and desire to secure by Letters Patent is:

1. A box comprising a bottom, end and side members provided with cover flaps, selected flaps being scored to provide hinged wings and form supports for a superimposed box, and means for anchoring said flaps in hingedly adjusted position.

2. A box having vertical walls including a wall having an upper edge cover flap hinged thereto and having a hinge spaced from said wall to provide a flap wing hingedly adjustable for support by said wall to provide a support for a superimposed box, and a clip engageable with selected portions of said hinge for retaining said wing in box-supporting position.

3. A box including a pair of end and side walls, cover flaps hinged to the upper edges of one pair of walls and having hinged portions spaced from said walls to form wings arranged to be folded back upon the cover flaps to provide ventilating passages therebetween and above the other of said pair of walls when a superimposed box is mounted thereon.

In testimony whereof I affix my signature.
IRVING HILL.