



(86) **Date de dépôt PCT/PCT Filing Date:** 2008/12/19
 (87) **Date publication PCT/PCT Publication Date:** 2009/07/09
 (45) **Date de délivrance/Issue Date:** 2017/01/03
 (85) **Entrée phase nationale/National Entry:** 2010/06/11
 (86) **N° demande PCT/PCT Application No.:** US 2008/087788
 (87) **N° publication PCT/PCT Publication No.:** 2009/086172
 (30) **Priorité/Priority:** 2007/12/19 (US61/015,143)

(51) **Cl.Int./Int.Cl. A61B 17/064** (2006.01),
A61B 17/04 (2006.01), **A61B 17/06** (2006.01),
A61B 17/068 (2006.01)

(72) **Inventeurs/Inventors:**
 CUMMINGS, GERALD F., CA;
 DRUBETSKY, LEV, CA;
 GORALTCHOUK, ALEXEI, CA;
 HERRMANN, ROBERT A., CA;
 NAIMAGON, ALEXANDER, CA

(73) **Propriétaire/Owner:**
 ETHICON, LLC, US

(74) **Agent:** NORTON ROSE FULBRIGHT CANADA
 LLP/S.E.N.C.R.L., S.R.L.

(54) **Titre : SUTURES AUTOBLOQUANTES INCLUANT DES ATTACHES FORMEES PAR CONTACT THERMIQUE**
 (54) **Title: SELF-RETAINING SUTURES WITH HEAT-CONTACT MEDIATED RETAINERS**

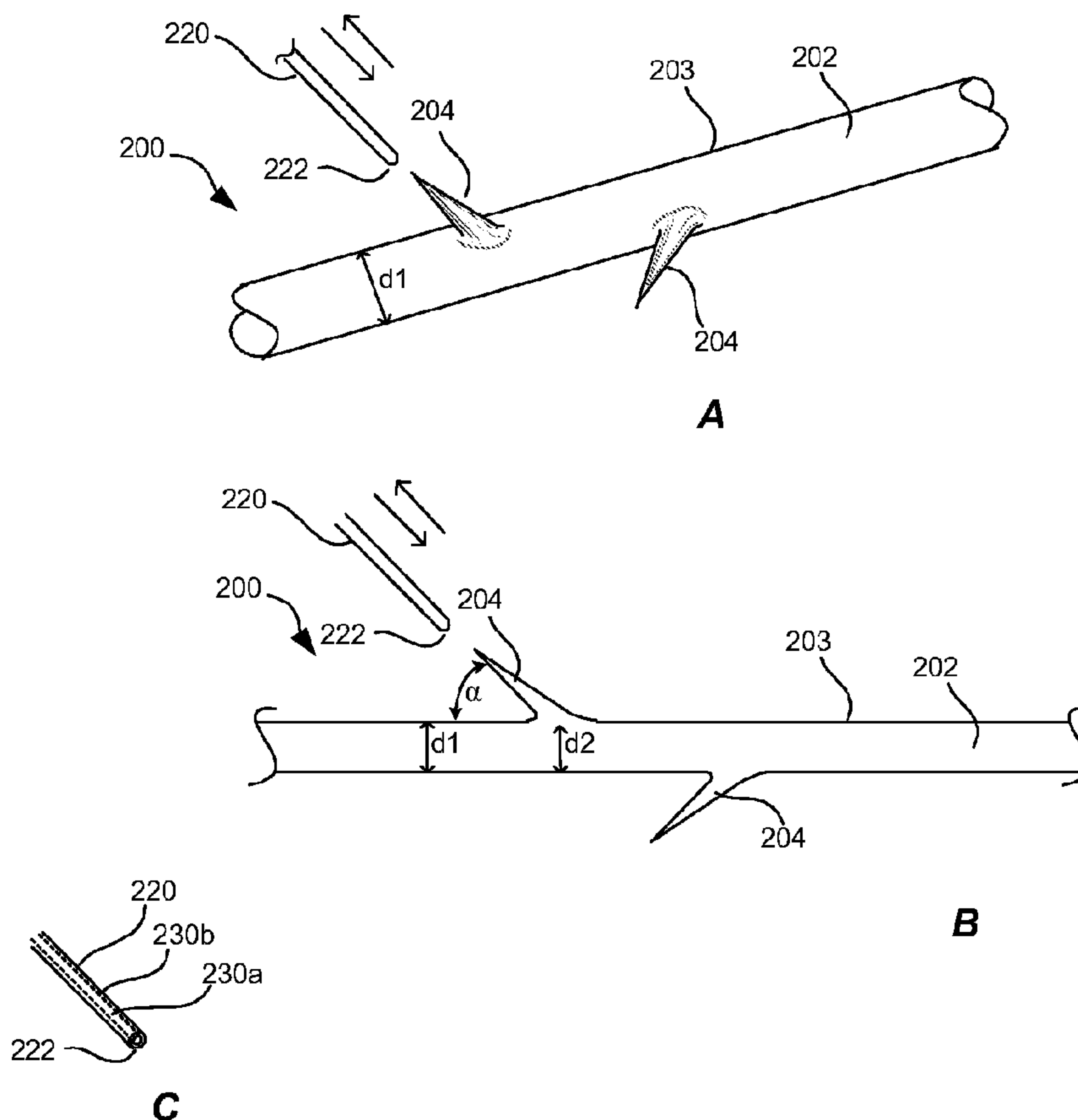

(57) **Abrégé/Abstract:**

Provided herein are sutures to be used in a procedure applied to tissue, and methods for forming such sutures. A suture can include an elongated suture body and a plurality of heat-contact mediated retainers extending from and along the elongated suture body. The heat-contact mediated retainers can be formed by temporarily contacting the elongated suture body with one or more heated element.

(12) INTERNATIONAL APPLICATION PUBLISHED UNDER THE PATENT COOPERATION TREATY (PCT)

(19) World Intellectual Property Organization
International Bureau(43) International Publication Date
9 July 2009 (09.07.2009)

PCT

(10) International Publication Number
WO 2009/086172 A2

(51) International Patent Classification:

A61B 17/064 (2006.01) A61B 17/06 (2006.01)
A61B 17/04 (2006.01)

(21) International Application Number:

PCT/US2008/087788

(22) International Filing Date:

19 December 2008 (19.12.2008)

(25) Filing Language:

English

(26) Publication Language:

English

(30) Priority Data:

61/015,143 19 December 2007 (19.12.2007) US

(71) Applicant (for all designated States except US): AN-
GIOTECH PHARMACEUTICALS, INC. [CA/CA];
1618 Station Street, Vancouver, British Columbia V6A
1B6 (CA).

(72) Inventors; and

(75) Inventors/Applicants (for US only): GORALTCHOUK,
Alexei [CA/CA]; #314 8880 Jones Road, Richmond,
British Columbia V6Y 3Z1 (CA). DRUBETSKY, Lev
[CA/CA]; 2948 Waterford Place, Coquitlam, BritishColumbia V3E 2S9 (CA). CUMMINGS, Gerald, F.
[CA/CA]; 239 April Road, Port Moody, British Columbia
V3H 3V3 (CA). HERRMANN, Robert, A. [US/CA];
1508-1082 Seymour, Vancouver, British Columbia V6B
1X9 (CA). NAIMAGON, Alexander [CA/CA]; 11-8799
General Curric Road, Richmond, British Columbia V6Y
1H3 (CA).(74) Agents: MCMASTERS, David, D. et al.; P.O. Box 2840,
North Bend, Washington 98045 (US).(81) Designated States (unless otherwise indicated, for every
kind of national protection available): AE, AG, AL, AM,
AO, AT, AU, AZ, BA, BB, BG, BH, BR, BW, BY, BZ, CA,
CH, CN, CO, CR, CU, CZ, DE, DK, DM, DO, DZ, EC, EE,
EG, ES, FI, GB, GD, GE, GH, GM, GT, HN, HR, HU, ID,
IL, IN, IS, JP, KE, KG, KM, KN, KP, KR, KZ, LA, LC, LK,
LR, LS, LT, LU, LY, MA, MD, ME, MG, MK, MN, MW,
MX, MY, MZ, NA, NG, NI, NO, NZ, OM, PG, PH, PL, PT,
RO, RS, RU, SC, SD, SE, SG, SK, SL, SM, ST, SV, SY, TJ,
TM, TN, TR, TT, TZ, UA, UG, US, UZ, VC, VN, ZA, ZM,
ZW.(84) Designated States (unless otherwise indicated, for every
kind of regional protection available): ARIPO (BW, GH,
GM, KE, LS, MW, MZ, NA, SD, SL, SZ, TZ, UG, ZM,
ZW), Eurasian (AM, AZ, BY, KG, KZ, MD, RU, TJ, TM),

[Continued on next page]

(54) Title: SELF-RETAINING SUTURES WITH HEAT-CONTACT MEDIATED RETAINERS

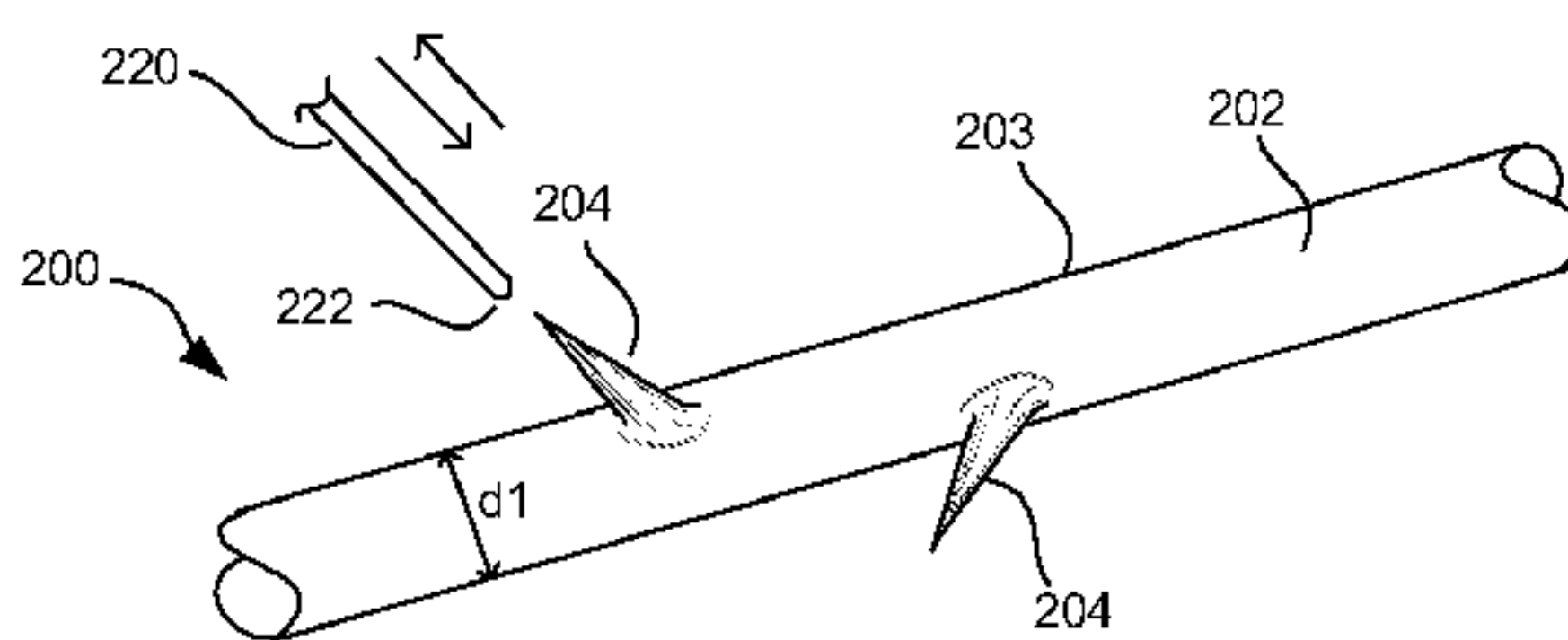

FIG. 2A

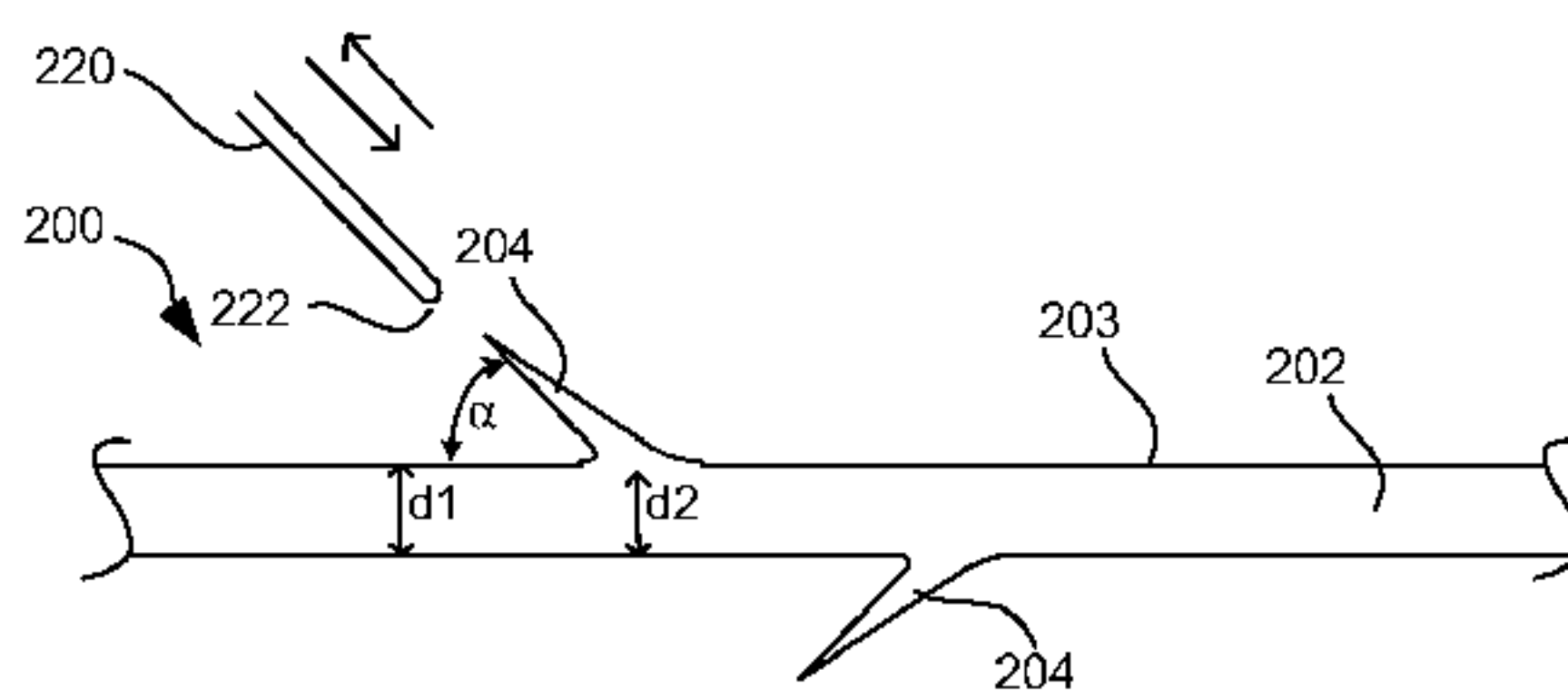

FIG. 2B

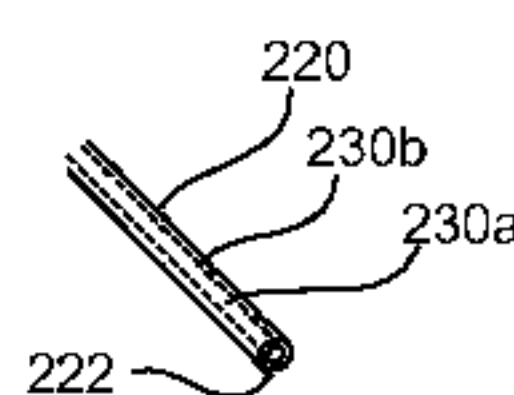

FIG. 2C

(57) Abstract: Provided herein are sutures to be used in a procedure applied to tissue, and methods for forming such sutures. A suture can include an elongated suture body and a plurality of heat-contact mediated retainers extending from and along the elongated suture body. The heat-contact mediated retainers can be formed by temporarily contacting the elongated suture body with one or more heated element.

WO 2009/086172 A2

WO 2009/086172 A2



European (AT, BE, BG, CH, CY, CZ, DE, DK, EE, ES, FI, FR, GB, GR, HR, HU, IE, IS, IT, LT, LU, LV, MC, MT, NL, NO, PL, PT, RO, SE, SI, SK, TR), OAPI (BF, BJ, CF, CG, CI, CM, GA, GN, GQ, GW, ML, MR, NE, SN, TD, TG).

Published:

— *without international search report and to be republished upon receipt of that report*

SELF-RETAINING SUTURES WITH HEAT-CONTACT MEDIATED RETAINERS

FIELD OF THE INVENTION

[0001] The present invention relates generally to self-retaining sutures for surgical procedures, methods of manufacturing self-retaining sutures for surgical procedures, and their uses.

BACKGROUND

[0002] Sutures are commonly used for closing or binding together wounds in human or animal tissue, such as skin, muscles, tendons, internal organs, nerves, and blood vessels. Sutures can be formed from non-absorbable material such as silk, nylon, polypropylene, or cotton, or alternatively sutures can be formed from bio-absorbable material such as, but not limited to, homopolymers and/or copolymers of glycolide, lactide, p-dioxanone and ϵ -caprolactone.

[0003] Sutures typically consist of a filamentous suture thread with a needle with a sharp point (attachment of sutures and surgical needles is described in U.S. Patent Nos. 3,981,307, 5,084,063, 5,102,418, 5,123,911, 5,500,991, 5,722,991, 6,012,216, and 6,163,948, and U.S. Patent Application Publication No. 2004/0088003).

[0004] Self-retaining sutures (often referred to as "barbed sutures") differ from conventional sutures in that they possess numerous tiny retainers (often barbs) which anchor into the surrounding tissue following deployment, thereby eliminating the need to tie knots to affix adjacent tissues together, and have been described in, for example, U.S. Pat. No. 6,848,152 and European Patent 1 075 843. Such retainers protrude from the suture periphery and are arranged to allow passage of the self-retaining suture when drawn in one direction (with respect to the direction of protrusion of the retainer) through tissue but resist movement of the self-retaining suture when drawn in the opposite direction. Retainers can reduce slippage of the suture at least in a direction along the suture and can optionally obviate knotting of the suture.

[0005] A self-retaining suture may be unidirectional, having one or more retainers oriented in one direction along the length of the suture thread; or bidirectional, typically having one or more retainers oriented in one direction along a portion of the thread, followed by one or more retainers oriented in another (often opposite) direction

over the remainder of the thread (as described in the context of barbed retainers in U.S. Patent Nos. 5,931,855 and 6,241,747). Although any number of sequential or intermittent configurations of retainers are possible, the most common form involves a needle at one end, followed by barbs projecting “away” from the needle until the transition point (often the midpoint) of the suture is reached; at the transition point the configuration of barbs reverses itself 180° (i.e., the barbs are now facing in the opposite direction) along the remaining length of the suture thread before attaching to a second needle at the opposite end. The disclosures of all patents and patent applications mentioned herein are incorporated by reference.

[0006] Single-directional self-retaining sutures can include an end that is pointed to allow penetration and passage through tissue when drawn by the end and an opposite end that includes an anchor for engaging tissue at the initial insertion point to limit movement of the suture. Alternatively, bi-directional self-retaining sutures can include retainers grouped and extending in one direction along one portion of the suture and opposing retainers grouped and extending in an opposing direction along another portion of the suture. When implanted so that both groups of retainers are engaging tissue, the retainers can resist movement of the suture through tissue in either direction.

[0007] A surgeon may use a surgical needle with an attached suture (which can be a smooth monofilament or can be a multi-filament) to pierce the tissue alternately on opposing faces of a wound to sew the wound closed. Techniques for placement of self-retaining sutures in tissue to close or bind together wounds can include threading the self-retaining suture in straight-line patterns such as zig-zag, and curvilinear patterns such as alpha, sinusoidal, and corkscrew. A surgeon may also use self-retaining sutures to position and support tissue where there is no wound in procedures such as cosmetic surgery of the face, neck, abdominal or thoracic region among others.

[0008] More specifically, self-retaining sutures can be used in superficial and deep surgical procedures in humans and animals for closing wounds, repairing traumatic injuries or defects, joining tissues together [bringing severed tissues into approximation, closing an anatomical space, affixing single or multiple tissue layers together, creating anastomoses between two hollow (luminal) structures, adjoining tissues, attaching or reattaching tissues to their proper anatomical location], attaching foreign elements to tissues (affixing medical implants, devices, prostheses and other functional or supportive devices), and for repositioning tissues to new anatomical

locations (repairs, tissue elevations, tissue grafting and related procedures) to name but a few examples.

[0009] Sutures typically consist of a filamentous suture thread attached to a needle with a sharp point (attachment of sutures and surgical needles is described in U.S. Patent Nos. 3,981,307, 5,084,063, 5,102,418, 5,123,911, 5,500,991, 5,722,991, 6,012,216, and 6,163,948, and U.S. Patent Application Publication No. US 2004/0088003). Classically, the needle is advanced through the desired tissue on one side of the wound and then through the adjacent side of the wound to form a “loop” which is then completed by tying a knot in the suture.

[0010] Sutures materials are broadly classified as being bioabsorbable (i.e., they break down completely in the body over time), such as those composed of catgut, glycolide polymers and copolymers, lactide polymers and copolymers, polyether-ester; or as being non-absorbable (permanent; nondegradable), such as those made of polyamide, polytetrafluoroethylene, polyethylene terephthalate, polyurethane, metal alloys, metal (e.g., stainless steel wire), polypropylene, polyethelene, silk, and cotton. Absorbable sutures have been found to be particularly useful in situations where suture removal might jeopardize the repair or where the natural healing process renders the support provided by the suture material unnecessary after wound healing has been completed; as in, for example, completing an uncomplicated skin closure. Nondegradable (non-absorbable) sutures are used in wounds where healing may be expected to be protracted or where the suture material is needed to provide physical support to the wound for long periods of time; as in, for example, deep tissue repairs, high tension wounds, many orthopedic repairs and some types of surgical anastomoses.

[0011] Self-retaining sutures are designed for engaging tissue when the suture is pulled in a direction other than that in which it was originally deployed in the tissue. Knotless tissue-approximating devices having barbs have been previously described in, for example, U.S. Pat. No. 5,374,268, disclosing armed anchors having barb-like projections, while suture assemblies having barbed lateral members have been described in U.S. Pat. Nos. 5,584,859 and 6,264,675. One of the earlier patents describing a barbed suture is U.S. Pat. No. 3,716,058, which discloses a suture having one or more relatively rigid barbs at its opposite ends; the presence of the barbs just at the ends of the suture would limit the barbs' effectiveness. Sutures having a plurality of barbs positioned along a greater portion of the suture are described in U.S. Pat No.

5,931,855, which discloses a unidirectional barbed suture, and U.S. Pat. No. 6,241,747, which discloses a bidirectional barbed suture. Methods and apparatus for forming barbs on sutures by cutting barbs into a suture body have been described in, for example, U.S. Pat. Nos. 6,848,152 and 7,225,512. Methods of manufacturing sutures with frusto-conical retainers have also been described, for example, in European Patent 1 075 843 and U.S. Pat. Publication No. 2007/0038429.

[0012] Despite the advantages of existing self-retaining sutures, there still remains a need and desire for new and preferably improved self-retaining sutures, and method of making the same.

SUMMARY

[0013] Provided herein are sutures to be used in a procedure applied to tissue, and methods for forming such sutures. A suture can include an elongated suture body and a plurality of heat-contact mediated retainers extending from and along the suture body. The heat-contact mediated retainers can be formed by temporarily contacting the elongated suture body with one or more heated element.

[0014] The details of one or more embodiments are set forth in the description below. Other features, objects and advantages will be apparent from the description, the drawings, and the claims. In addition, the disclosures of all patents and patent applications referenced herein are incorporated by reference in their entirety.

BRIEF DESCRIPTION OF THE DRAWINGS

[0015] FIG. 1 is perspective view of a portion of a conventional self-retaining suture having retainers cut into a suture body.

[0016] FIG. 2A is a perspective view of a portion of a self-retaining suture, according to an embodiment of the present invention, which includes a plurality of heat-contact mediated retainers extending from a suture body.

[0017] FIG. 2B is a side view of the portion of the self-retaining suture of FIG. 2A.

[0018] FIG. 2C is a perspective view of a portion of a heated element that includes an inner lumen within an outer lumen.

[0019] FIGS. 3A – 3D show how retainers can be made by temporarily contacting a heated element to a periphery of an elongated suture body, in accordance with an embodiment of the present invention.

[0020] FIG. 4 is a side view of a heat conductive block that includes a plurality of heat conductive elements extending therefrom, which can be used to produce self-retaining sutures in accordance with embodiments of the present invention.

[0021] FIGS. 5A and 5B illustrate how a heated element and suture body can be moved in different directions, relative to one another, to form self-retaining sutures in accordance with embodiments of the present invention.

[0022] FIG. 6 is a side view of a portion of a self-retaining suture that includes heat-contact mediated retainers of varying sizes, in accordance with embodiments of the present invention.

[0023] FIG. 7 is a high level flow diagram that is used to summarize methods of forming self-retaining sutures in accordance with embodiments of the present invention.

DETAILED DESCRIPTION OF THE INVENTION

[0024] Prior to setting forth the invention, it may be helpful to an understanding thereof to first set forth definitions of certain terms that are used hereinafter.

[0025] “Self-retaining system” refers to a self-retaining suture together with means for deploying the suture into tissue. Such deployment means include, without limitation, suture needles and other deployment devices as well as sufficiently rigid and sharp ends on the suture itself to penetrate tissue.

[0026] “Self-retaining suture” refers to a suture that does not require a knot or a suture anchor at its end in order to maintain its position into which it is deployed during a surgical procedure. These may be monofilament sutures or braided sutures, and are positioned in tissue in two stages, namely deployment and affixation, and include at least one tissue retainer.

[0027] “Tissue retainer” (or simply “retainer” or “barb”) refers to a suture element having a retainer body projecting from the suture body and a retainer end adapted to penetrate tissue. Each retainer is adapted to resist movement of the suture in a direction other than the direction in which the suture is deployed into the tissue by the surgeon, by being oriented to substantially face the deployment direction. As the tissue-penetrating end of each retainer moving through tissue during deployment faces away

from the deployment direction (the direction of the passage of the suture during deployment), the tissue retainers should not catch or grab tissue during this phase. Once the self-retaining suture has been deployed, a force exerted in another direction, often substantially opposite to the deployment direction, to affix the suture in position causes retainers to be displaced from their deployment positions of resting substantially along the suture body and causes retainer ends to penetrate into the tissue resulting in tissue being caught between the retainer and the suture body.

[0028] “Retainer configurations” refers to configurations of tissue retainers and can include features such as size, shape, surface characteristics, and so forth. These are sometimes also referred to as “barb configurations”.

[0029] “Bidirectional suture” refers to a self-retaining suture having retainers oriented in one direction at one end and retainers oriented in the other direction at the other end. A bidirectional suture is typically armed with a needle at each end of the suture thread. Many bidirectional sutures have a transitional segment located between the two barb orientations.

[0030] “Transition segment” refers to a retainer-free (barb-free) portion of a bidirectional suture located between a first set of retainers (barbs) oriented in one direction and a second set of retainers (barbs) oriented in another direction.

[0031] “Suture thread” refers to the filamentary body component of the suture, and, for sutures requiring needle deployment, does not include the suture needle. The suture thread may be monofilamentary, or, multifilamentary.

[0032] “Monofilament suture” refers to a suture comprising a monofilamentary suture thread.

[0033] “Braided suture” refers to a suture comprising a multifilamentary suture thread. The filaments in such suture threads are typically braided, twisted, or woven together.

[0034] “Degradable (also referred to as “biodegradable” or “bioabsorbable”) suture” refers to a suture which, after introduction into a tissue is broken down and absorbed by the body. Typically, the degradation process is at least partially mediated by, or performed in, a biological system. “Degradation” refers to a chain scission process by which a polymer chain is cleaved into oligomers and monomers. Chain scission may occur through various mechanisms, including, for example, by chemical reaction (e.g., hydrolysis, oxidation/reduction, enzymatic mechanisms or a combination

or these) or by a thermal or photolytic process. Polymer degradation may be characterized, for example, using gel permeation chromatography (GPC), which monitors the polymer molecular mass changes during erosion and breakdown. Degradable suture material may include polymers such as polyglycolic acid, copolymers of glycolide and lactide, copolymers of trimethylene carbonate and glycolide with diethylene glycol (*e.g.*, MAXON™, Tyco Healthcare Group), terpolymer composed of glycolide, trimethylene carbonate, and dioxanone (*e.g.*, BIOSYN™ [glycolide (60%), trimethylene carbonate (26%), and dioxanone (14%)], Tyco Healthcare Group), copolymers of glycolide, caprolactone, trimethylene carbonate, and lactide (*e.g.*, CAPROSYN™, Tyco Healthcare Group). These sutures can be in either a braided multifilament form or a monofilament form. The polymers used in the present invention can be linear polymers, branched polymers or multi-axial polymers. Examples of multi-axial polymers used in sutures are described in U.S. Patent Application Publication Nos. 20020161168, 20040024169, and 20040116620. Degradable sutures can also include dissolvable sutures made of a dissolvable polymer, such as a polyvinyl alcohol partly deacetylated polymer, but not limited thereto. Sutures made from degradable suture material lose tensile strength as the material degrades.

[0035] “Non-degradable (also referred to as “non-absorbable”) suture” refers to a suture comprising material that is not degraded by chain scission such as chemical reaction processes (*e.g.*, hydrolysis, oxidation/reduction, enzymatic mechanisms or a combination or these) or by a thermal or photolytic process. Non-degradable suture material includes polyamide (also known as nylon, such as nylon 6 and nylon 6.6), polyester (*e.g.*, polyethylene terephthalate), polytetrafluoroethylene (*e.g.*, expanded polytetrafluoroethylene), polyether-ester such as polybutester (block copolymer of butylene terephthalate and polytetra methylene ether glycol), polyurethane, metal alloys, metal (*e.g.*, stainless steel wire), polypropylene, polyethelene, silk, and cotton. Sutures made of non-degradable suture material are suitable for applications in which the suture is meant to remain permanently or is meant to be physically removed from the body.

[0036] “Suture diameter” refers to the diameter of the body of the suture. It is to be understood that a variety of suture lengths may be used with the sutures described herein and that while the term “diameter” is often associated with a circular periphery,

it is to be understood herein to indicate a cross-sectional dimension associated with a periphery of any shape. Suture sizing is based upon diameter. United States Pharmacopeia (“USP”) designation of suture size runs from 0 to 7 in the larger range and 1-0 to 11-0 in the smaller range; in the smaller range, the higher the value preceding the hyphenated zero, the smaller the suture diameter. The actual diameter of a suture will depend on the suture material, so that, by way of example, a suture of size 5-0 and made of collagen will have a diameter of 0.15 mm, while sutures having the same USP size designation but made of a synthetic absorbable material or a non-absorbable material will each have a diameter of 0.1 mm. The selection of suture size for a particular purpose depends upon factors such as the nature of the tissue to be sutured and the importance of cosmetic concerns; while smaller sutures may be more easily manipulated through tight surgical sites and are associated with less scarring, the tensile strength of a suture manufactured from a given material tends to decrease with decreasing size. It is to be understood that the sutures and methods of manufacturing sutures disclosed herein are suited to a variety of diameters, including without limitation 7, 6, 5, 4, 3, 2, 1, 0, 1-0, 2-0, 3-0, 4-0, 5-0, 6-0, 7-0, 8-0, 9-0, 10-0 and 11-0.

[0037] “Suture deployment end” refers to an end of the suture to be deployed into tissue; one or both ends of the suture may be suture deployment ends. The suture deployment end may be attached to deployment means such as a suture needle, or may be sufficiently sharp and rigid to penetrate tissue on its own.

[0038] “Armed suture” refers to a suture having a suture needle on at least one suture deployment end.

[0039] “Needle attachment” refers to the attachment of a needle to a suture requiring same for deployment into tissue, and can include methods such as crimping, swaging, using adhesives, and so forth. The point of attachment of the suture to the needle is known as the swage.

[0040] “Suture needle” refers to needles used to deploy sutures into tissue, which come in many different shapes, forms and compositions. There are two main types of needles, traumatic needles and atraumatic needles. Traumatic needles have channels or drilled ends (that is, holes or eyes) and are supplied separate from the suture thread and are threaded on site. Atraumatic needles are eyeless and are attached to the suture at the factory by swaging whereby the suture material is inserted into a channel at the blunt end of the needle which is then deformed to a final shape to hold the suture

and needle together. As such, atraumatic needles do not require extra time on site for threading and the suture end at the needle attachment site is smaller than the needle body. In the traumatic needle the thread comes out of the needle's hole on both sides and often the suture rips the tissues to a certain extent as it passes through. Most modern sutures are swaged atraumatic needles. Atraumatic needles may be permanently swaged to the suture or may be designed to come off the suture with a sharp straight tug. These "pop-offs" are commonly used for interrupted sutures, where each suture is only passed once and then tied. For barbed sutures that are uninterrupted, these atraumatic needles would be ideal.

[0041] Suture needles may also be classified according to their point geometry. For example, needles may be (i) "tapered" whereby the needle body is round and tapers smoothly to a point; (ii) "cutting" whereby the needle body is triangular and has sharpened cutting edge on the inside; (iii) "reverse cutting" whereby the cutting edge is on the outside; (iv) "trocar point" or "tapercut" whereby the needle body is round and tapered, but ends in a small triangular cutting point; (v) "blunt" points for sewing friable tissues; (vi) "side cutting" or "spatula points" whereby the needle is flat on top and bottom with a cutting edge along the front to one side (these are typically used for eye surgery).

[0042] Suture needles may also be of several shapes including, (i) straight, (ii) half curved or ski, (iii) 1/4 circle, (iv) 3/8 circle, (v) 1/2 circle, (vi) 5/8 circle, (v) and compound curve.

[0043] Suturing needles are described, for example, in US Patent Nos. 6,322,581 and 6,214,030 (Mani, Inc., Japan); and 5,464,422 (W.L. Gore, Newark, DE); and 5,941,899; 5,425,746; 5,306,288 and 5,156,615 (US Surgical Corp., Norwalk, CT); and 5,312,422 (Linvatec Corp., Largo, FL); and 7,063,716 (Tyco Healthcare, North Haven, CT). Other suturing needles are described, for example, in US Patent Nos. 6,129,741; 5,897,572; 5,676,675; and 5,693,072. The sutures described herein may be deployed with a variety of needle types (including without limitation curved, straight, long, short, micro, and so forth), needle cutting surfaces (including without limitation, cutting, tapered, and so forth), and needle attachment techniques (including without limitation, drilled end, crimped, and so forth). Moreover, the sutures described herein may themselves include sufficiently rigid and sharp ends so as to dispense with the requirement for deployment needles altogether.

[0044] “Needle diameter” refers to the diameter of a suture deployment needle at the widest point of that needle. While the term “diameter” is often associated with a circular periphery, it is to be understood herein to indicate a cross-sectional dimension associated with a periphery of any shape.

[0045] “Wound closure” refers to a surgical procedure for closing of a wound. An injury, especially one in which the skin or another external or internal surface is cut, torn, pierced, or otherwise broken is known as a wound. A wound commonly occurs when the integrity of any tissue is compromised (e.g., skin breaks or burns, muscle tears, or bone fractures). A wound may be caused by an act, such as a gunshot, fall, or surgical procedure; by an infectious disease; or by an underlying medical condition. Surgical wound closure facilitates the biological event of healing by joining, or closely approximating, the edges of those wounds where the tissue has been torn, cut, or otherwise separated. Surgical wound closure directly apposes or approximates the tissue layers, which serves to minimize the volume new tissue formation required to bridge the gap between the two edges of the wound. Closure can serve both functional and aesthetic purposes. These purposes include elimination of dead space by approximating the subcutaneous tissues, minimization of scar formation by careful epidermal alignment, and avoidance of a depressed scar by precise eversion of skin edges.

[0046] “Tissue elevation procedure” refers to a surgical procedure for repositioning tissue from a lower elevation to a higher elevation (i.e. moving the tissue in a direction opposite to the direction of gravity). The retaining ligaments of the face support facial soft tissue in the normal anatomic position. However, with age, gravitational effects achieve a downward pull on this tissue and the underlying ligaments, and fat descends into the plane between the superficial and deep facial fascia, thus allowing facial tissue to sag. Face-lift procedures are designed to lift these sagging tissues, and are one example of a more general class of medical procedure known as a tissue elevation procedure. More generally, a tissue elevation procedure reverses the appearance change that results from gravitation effects over time, and other temporal effects that cause tissue to sag, such as genetic effects. It should be noted that tissue can also be repositioned without elevation; in some procedures tissues are repositioned laterally (away from the midline), medially (towards the midline) or

inferiorly (lowered) in order to restore symmetry (i.e. repositioned such that the left and right sides of the body “match”).

[0047] “Medical device” or “implant” refers to any object placed in the body for the purpose of restoring physiological function, reducing/alleviating symptoms associated with disease, and/or repairing/replacing damaged or diseased organs and tissues. While normally composed of biologically compatible synthetic materials (e.g., medical-grade stainless steel, titanium and other metals; polymers such as polyurethane, silicon, PLA, PLGA and other materials) that are exogenous, some medical devices and implants include materials derived from animals (e.g., “xenografts” such as whole animal organs; animal tissues such as heart valves; naturally occurring or chemically-modified molecules such as collagen, hyaluronic acid, proteins, carbohydrates and others), human donors (e.g., “allografts” such as whole organs; tissues such as bone grafts, skin grafts and others), or from the patients themselves (e.g., “autografts” such as saphenous vein grafts, skin grafts, tendon/ligament/muscle transplants). Medical devices that can be used in procedures in conjunction with the present invention include, but are not restricted to, orthopaedic implants (artificial joints, ligaments and tendons; screws, plates, and other implantable hardware), dental implants, intravascular implants (arterial and venous vascular bypass grafts, hemodialysis access grafts; both autologous and synthetic), skin grafts (autologous, synthetic), tubes, drains, implantable tissue bulking agents, pumps, shunts, sealants, surgical meshes (e.g., hernia repair meshes, tissue scaffolds), fistula treatments, spinal implants (e.g., artificial intervertebral discs, spinal fusion devices, etc.) and the like.

A. Self-Retaining Sutures

[0048] Self-retaining sutures (including barbed sutures) differ from conventional sutures in that they possess numerous tiny tissue retainers (such as barbs) which anchor into the tissue following deployment and resist movement of the suture in a direction opposite to that in which the retainers face, thereby eliminating the need to tie knots to affix adjacent tissues together (a “knotless” closure). By eliminating knot tying, associated complications are eliminated, including, but not limited to (i) spitting (a condition where the suture, usually a knot) pushes through the skin after a subcutaneous closure), (ii) infection (bacteria are often able to attach and grow in the spaces created by a knot), (iii) bulk/mass (a significant amount of suture material left in

a wound is the portion that comprises the knot), (iv) slippage (knots can slip or come untied), and (v) irritation (knots serve as a bulk “foreign body” in a wound). Suture loops associated with knot tying may lead to ischemia (they create tension points that can strangulate tissue and limit blood flow to the region) and increased risk of dehiscence or rupture at the surgical wound. Knot tying is also labor intensive and can comprise a significant percentage of the time spent closing a surgical wound. Additional operative procedure time is not only bad for the patient (complication rates rise with time spent under anesthesia), but it also adds to the overall cost of the operation (many surgical procedures are estimated to cost between \$15 and \$30 per minute of operating time). Thus, knotless sutures not only allow patients to experience an improved clinical outcome, but they also save time and costs associated with extended surgeries and follow-up treatments.

[0049] Self-retaining systems for wound closure also result in better approximation of the wound edges, evenly distribute the tension along the length of the wound (reducing areas of tension that can break or lead to ischemia), decrease the bulk of suture material remaining in the wound (by eliminating knots) and reduce spitting (the extrusion of suture material – typically knots - through the surface of the skin. All of these features are thought to reduce scarring, improve cosmesis, and increase wound strength relative to wound closures effected with plain sutures or staples.

[0050] The ability of self-retaining sutures to anchor and hold tissues in place even in the absence of tension applied to the suture is a feature that also provides superiority over plain sutures. When closing a wound that is under tension, this advantage manifests itself in several ways: (i) a multiplicity of retainers can dissipate tension along the entire length of the suture (providing hundreds of “anchor” points as opposed to knotted interrupted sutures which concentrate the tension at discrete points; this produces a superior cosmetic result and lessens the chance that the suture will “slip” or pull through); (ii) complicated wound geometries can be closed (circles, arcs, jagged edges) in a uniform manner with more precision and accuracy than can be achieved with interrupted sutures; (iii) they eliminate the need for a “third hand” which is often required for maintaining tension across the wound during traditional suturing and knot tying (to prevent “slippage” when tension is momentarily released during tying); (iv) they are superior in procedures where knot tying is technically difficult, such as in deep wounds or laparoscopic procedures; and (v) they can be used to

approximate and hold the wound prior to definitive closure. As a result, self-retaining sutures provide easier handling in anatomically tight or deep places (such as the pelvis, abdomen and thorax) and make it easier to approximate tissues in laparoscopic and minimally invasive procedures; all without having to secure the closure via a knot. Greater accuracy allows self-retaining sutures to be used for more complex closures (such as those with diameter mismatches, larger defects or purse string suturing) than can be accomplished with plain sutures.

[0051] Self-retaining sutures also lend themselves to a variety of specialized indications; for example, they are suitable for tissue elevation procedures where tissue is moved from its previous location and repositioned into a new anatomical location (this is typically performed in cosmetic procedures where “drooping” tissue is elevated and fixed in a more “youthful” position; or where “out-of-position” tissue is moved back to its correct anatomical location). Such procedures include facelifts, brow lifts, breast lifts, buttocks lifts, and so forth.

[0052] A self-retaining suture may be unidirectional, having one or more retainers oriented in one direction along the length of the suture thread; or bidirectional, typically having one or more retainers oriented in one direction along a portion of the thread, followed by one or more retainers oriented in another (often opposite) direction over the remainder of the thread (as described with barbed retainers in U.S. Pat. Nos. 5,931,855 and 6,241,747).

[0053] Although any number of sequential or intermittent configurations of retainers are possible, a common form involves a needle at one end, followed by barbs projecting “away” from the needle until the transition point (often the midpoint) of the suture is reached; at the transition point the configuration of barbs reverses itself about 180° (such that the barbs are now facing in the opposite direction) along the remaining length of the suture thread before attaching to a second needle at the opposite end (with the result that the barbs on this portion of the suture also face away from the nearest needle). Put another way, the barbs on both “halves” of a bidirectional self-retaining suture point towards the middle, with a transition segment (lacking retainers) interspersed between them, and with a needle attached to either end.

[0054] As mentioned above, despite the multitude of advantages of self-retaining sutures, there remains a need and desire to improve upon the design of such sutures so that a variety of common limitations can be eliminated. For example,

retainers formed by cutting into a suture body have a tendency to sometimes lie flat, i.e., not stand up or fan out as desired. Additionally, many existing techniques (e.g., cutting techniques) for manufacturing self-retaining sutures may reduce the tensile strength of the suture, as explained below.

B. Conventionally Formed Retainers

[0055] FIG. 1 shows a perspective view of a portion of a typical self-retaining suture 100 that includes a suture body 102 and barb like retainers 104 projecting from the suture body 102. Here, the retainers 104 were formed by forming cuts 106 in the suture body 102, e.g., using a cutting blade. As can be appreciated from FIG. 1, the diameter of the suture body 102 is reduced from d_1 to d_2 at the locations along the suture body 102 where the retainers 104 were cut from the suture body 102 (i.e., where the cuts 106 are formed). As with a chain that is only as strong as its weakest link, the tensile strength of suture 100 may be reduced due to the reductions in diameter and stress concentrated at the apex 108 of each cut 106.

C. Heat Contact Mediated Retainers

[0056] FIG. 2A shows a perspective view of a portion of a self-retaining suture 200, according to an embodiment of the present invention, that includes an elongated threadlike suture body 202 and a plurality of retainers 204 projecting from the suture body 202. FIG. 2B is a side view of the self-retainer suture 200. Here, the retainers 204 are formed by temporarily contacting portions of the outer periphery 203 of the elongated suture body 202 with one or more heated element (illustrated as element 220). When such a heated element 220 contacts the suture body 202, it will cause local melting of the suture body 202. In other words, the portion of the suture body 202 that is contacted by the heated element will melt, as may also a small portion of the suture body close to the contact point. Thereafter, when the heated element 220 is moved away from the suture body 202 (and/or the suture body 202 is move away from the heated element), some of the melted suture body will locally whip up, e.g., into a shape of a generally conical barb, to form a retainer 204 when cooled (proactively cooled or allowed to cool back to ambient temperature). Because of the way in which the retainers are formed, the retainers 204 can also be referred to as heat-contact mediated retainers 204.

[0057] In FIGS. 2A and 2B the heated element 220 is shown as including a most distal portion or tip 222, which can be the portion of the heated element 220 that temporarily contacts the circumferential periphery 203 of the suture body 202. The shape and/or size of the tip 222 can affect the shape and size of the retainer 204 formed using the heated element 220. For example, all other conditions being equal, the smaller the diameter of the tip 222 the smaller the diameter of the retainer 204 formed using the tip, and the larger the diameter of the tip 222 the larger the diameter of the retainer 204 formed using the tip. Exemplary shapes of the tip 222, which can affect the shape of the retainers 204 formed using the tip 222, include round, square, triangular, V-shaped, O-shaped but are not limited thereto. It is also possible that a portion of the heated element 220 other than its tip 222 temporarily contact the elongated suture body 202 to form retainers 204.

[0058] Referring to FIG. 2C, an O-shaped tip 222 can be provided by an inner lumen 230a within an outer lumen 230b. The outer lumen 230b can be heated, and the inner lumen 230a can be used to clean the tip 222, by configuring the inner lumen 230a to dispense high pressure air or some other gas during periods when the heated element 220 is not contacting a suture body. Alternatively, or additionally, the inner lumen 230a can provide vacuum suction to assist in pulling up the melted portion of the suture body to help form the retainers 204. In still another embodiment, the inner lumen 230a can dispense a molten material and the outer lumen 230b can be heated (or vice versa) and contacted against the periphery 203 of the suture body 204 during, or just prior to, the dispensing of the molten material. When such a heated outer lumen 230b (or heated inner lumen 230a) contacts the suture body 202, it will cause local melting of the suture body 202. Thereafter, when the heated lumen is moved away from the suture body 202 (and/or the suture body 202 is move away from the heated lumen), some of the melted suture body may meld with the dispensed molten material (dispensed by the other lumen), providing for a strong bond between the suture body and the formed retainers 204. Such dual lumen embodiments are not limited to use with an O-shaped tip 222, as other shaped lumens (e.g., triangle, oval, square, etc) can be used. It's also possible that the inner lumen and the outer lumen have different shapes, resulting in a mixed shaped tip 222.

[0059] In an embodiment, a heated element 220 (which can also be referred to as a heating element) includes a resistive element that converts electricity to heat, e.g.,

through the process of Joule heating. The heated element 220 can be made of, e.g., Nichrome, or can be a metal deposited on a ceramic, but is not limited thereto. The heated element 220 can be, e.g., a Calrod, which is a fine coil of Nichrome wire in a ceramic binder, sealed inside a tough metal shell. The heated element 220 can alternatively be made of a Positive Thermal Coefficient (PTC) ceramic, e.g., barium titanate or lead titanate composites. The heated element 220 can alternatively be made of exotic materials, including platinum, molybdenum disilicide, and silicon carbide. These are just a few examples, which are not meant to be limiting.

[0060] The shape and size of the resulting retainers 204 can also be affected, and thereby controlled, by the speed and/or acceleration of the contact and withdrawal of the heated element 220, the temperature of the heated element 220, the pressure during contact, and the duration of the contact.

[0061] Although only two retainers 204 are shown, this is for simple illustrative purposes only. It is likely that the suture 200 of FIGS. 2A and 2B, and the sutures of the remaining FIGS., can include hundreds of retainers 204, although more or less are possible. The periodicity and arrangement of the retainers 204 can be random or organized to maximize or otherwise adjust tissue engagement strength. It is also noted that the FIGS. are not necessarily drawn to scale, i.e., it is likely that the retainers 204 are not as large as shown relative to the suture body 202.

[0062] The heated element 220 and the suture body 202 can be brought into contact with one another by moving the elongated suture body 202 and/or the heated element 220, relative to one another, so that the heated element 220 comes in contact with the circumferential periphery 203 of the elongated suture body 202 and locally melts a portion of the elongated suture body 202. In other words, the heated element 220 can be moved toward the suture body 202, the suture body 202 can be moved toward the heated element 220, or both can be moved toward one another. Thereafter, the elongated suture body 202 and/or the heated element 220 are moved relative to one another (e.g., one away from the other), so that the heated element 220 is no longer in contact with the circumferential periphery 203 of the elongated suture body 202, and so that at least some of the melted portion of the elongated body protrudes from the circumferential periphery 203 and forms a retainer 204 when cooled.

[0063] The above described process is illustrated in more detail with reference to FIGS. 3A-3D. More specifically, FIG. 3A shows that heated element 220 being

moved toward the elongated suture body 202. FIG. 3B shows the tip 222 of the heated element 220 contacting the circumferential periphery 203 of the elongated suture body 202, which will cause a portion of the body 202, local to the contact point, to melt. FIG. 3C shows the heated element 220 being moved away from the suture body 202, and that some of the melted suture body material is pulled away from the circumferential periphery 203 and begins to form the retainer 204. FIG. 3D shows that as the heated element 220 is moved further away from the suture body 202, the melted suture body material will separate from the heated element 220. The resulting locally whipped-up or pulled suture material forms the final retainer 204 when cooled. In some embodiments, a blade, or the like, can be used to separate the melted suture body (e.g., the portion used to form the retainer) from the heated element 220, e.g., by cutting off the material from the heated element. Also, a blade, or the like, can be used to clean molten material off the heated element 220. While the suture body 202 can have a circular cross-section, this is not required, and use of the terms circumference and circumferential are not intended to imply a circular cross-section. For example, the cross-section of the suture body 202 can alternatively be oval, square, triangular, octagonal, or any other regular geometric shape. Alternatively the cross-section of the suture body can be of a random shape which varies along the length of the suture body to facilitate better engagement to the tissues.

[0064] The angle at which the heated element approaches and/or is moved away from the suture body 202 can affect the angle of the resulting retainer 204. For example, if the suture body 202 is static, and the heated element 220 moves towards and away from the suture body 202 at an acute angle α , the resulting retainer 204 will generally have an angle of α relative to the longitudinal axis of the elongated suture body 202, as can be appreciated from FIG. 3D.

[0065] A plurality of retainers 204 can be formed by repeatedly using the same heated element to form all of the retainers 204. Alternatively, multiple heated elements can be used to thereby form a plurality of the retainers 204 simultaneously. For example, referring to FIG. 4, at least some of the plurality of heated elements 220 can be heat conductive elements 420 that extend from a common heat conductive body 402, where the heat conductive elements 420 are heated when the heat conductive body 402 is heated. The heat conductive elements 420 and heat conductive body 402 can be made of, e.g., a heat conductive metal, or some other heat conductive material.

[0066] In specific embodiments, the heated element 220 is moved towards and away from the elongated suture body 202, to temporarily contact the elongated suture body 202, while the elongated suture body 202 is not moving. In other embodiments, the elongated suture body 202 is moved in a first direction (illustrated by arrow 502 in FIGS. 5A and 5B), and while the elongated suture body is being moved in the first direction 502, the heated element 220 is moved toward the elongated suture body 202 in a second direction (illustrated by arrow 504 in FIGS. 5A and 5B) that is at an angle relative to the first direction 502. The second direction 504 can be generally perpendicular to the first direction 502, as shown in FIG. 5A. Alternatively, second direction 504 can be at an obtuse angle or a acute angle relative to the first direction 502, as shown in FIG. 5B. In such embodiments, the speed at which the elongated suture body 202 is being moved can also affect the size and shape of the resulting retainers 204, as can the other factors discussed above (e.g., contact duration, contact pressure, the shape and size of heated element contact portion, the speed and/or acceleration of the movement of heated element, etc.).

[0067] A benefit of embodiments of the present invention is that retainers 204 can be formed on a suture body 202 that has a relatively small diameter, where it may be difficult to form cut retainers into the body 202 using conventional cutting techniques. Additionally, while the diameter of the suture body 202 may be reduced at the locations of the retainers (due to portions of the suture body 202 being used to make the retainers), the reduction in diameter will likely be less than if retainers were cut into the suture body 202. Further, the suture with heat-contact mediated retainers is also smoother and includes no cuts and stress points (areas of stress concentration) resulting from cuts, all of the above can serve to maintain a high tensile strength of the suture. In other words, the absence of a cut, and an apex of the cut, eliminates stress concentration effects which would otherwise be present and further helps retain the original tensile strength of the suture.

[0068] Shown in FIG. 6 is a side view of a self-retaining suture 200 that includes heat-contact mediated retainers 204 of varying sizes. For example, retainers 204a are closely spaced to one another and relatively small in size with a relatively short length as compared to retainers 204b, which are relatively medium in size with a relatively medium length, as compared to retainers 204c, which are relatively large in size with a relatively long length. The periodicity of such retainers can be random or

organized, such that for example retainers 204a occur in groups in a series and then followed by retainers 204b which occur in groups in a series, followed by retainers 204c. The order of occurrence and the size of the groups may be altered to maximize tissue engagement strength. The self-retaining suture 200 of FIG. 6 can be made by using different sized heated elements 220, different temperatures, different contact and withdrawal speeds and/or acceleration, different contact pressure and/or contact duration, etc. The different sized heat-contact mediated retainers 204 are designed for various surgical applications. The retainer size may also vary in the transverse direction, whereby the base of the retainers may be short, medium, or long, and regardless, the suture base typically is less than about 1/4 of the suture diameter. For instance, relatively larger or longer heat-contact mediated retainers 204c are desirable for joining fat and soft tissues, whereas relatively smaller or shorter heat-contact mediated retainers 204a are desirable for joining fibrous tissues. Use of a combination of large, medium, and/or small sized retainers on the same suture helps to ensure maximum anchoring properties when retainers sizes are customized for each tissue layer. Only two different sized sets of retainers (not shown) may be formed to the suture body 202, or additional sets of retainers (not shown) with four, five, six, or more different sized sets than three sizes as illustrated may be formed to the suture body 202 as desired, in accordance with the intended end use.

[0069] The heat-contact mediated retainers 204, after being formed, can be treated to increase the stiffness and strength of the retainers, e.g., by appropriate annealing cycles (heating to a certain temperature and cooling at a certain rate) of the retainers 204, e.g., using techniques similar to those taught in U.S. Patent No. 5,007,922, which is incorporated herein by reference.

[0070] The retainers 204 and the suture body 202 can both be made of bio-absorbable material, examples of which were provided. Alternatively, the retainers 204 and the suture body 202 can both be made of non-absorbable material, examples of which were also provided above. In another embodiment of this invention the retainers 204 and the suture body 202 can be partially bio-absorbable.

[0071] The heat-contact mediated retainers 204 can be angled or canted such that the retainers substantially yield to motion of the elongated suture body 202 within the tissue when the suture 200 is drawn in one suture deployment direction and resist motion if the suture 200 is drawn in an opposite suture deployment direction. The self-

retaining sutures can have heat-contact mediated retainers 204 that are unidirectional or bidirectional. If unidirectional, the self-retaining sutures can include an end that is pointed or has a needle to allow penetration and passage through tissue when drawn by the end and an opposite end that in some embodiments includes an anchor for engaging tissue at the initial insertion point to limit movement of the suture. If bidirectional, the self-retaining sutures can include retainers grouped and extending toward one deployment direction along one portion of the suture and opposing retainers grouped and extending toward an opposing deployment direction along another portion of the suture. Accordingly, when such a bi-directional suture is implanted, both groups of retainers are engaging tissue, and the retainers can resist movement of the suture through tissue in either direction. Also, a bidirectional suture can be armed with a needle at each end of the suture thread. A bidirectional suture can also have a transitional segment located between the two groups of retainers.

[0072] The high level flow diagram of FIG. 7 summarizes how sutures, in accordance with specific embodiments of the present invention, can be manufactured. Referring to FIG. 7, at step 702, an elongated suture body is provided, where the elongated suture body has a first end, a second end and a circumferential periphery. At step 704, retainers are formed on the elongated suture body by temporarily contacting the circumferential periphery of the of the elongated suture body with one or more heated element. Additionally, heat-contact mediated retainers can formed at one or both ends of the elongated suture body, e.g., to form an anchor type retainer.

[0073] As mentioned above, the retainers 204 can be formed so the retainers substantially yield to motion of the elongated suture body within the tissue when the elongated suture body is drawn in a first direction and resist motion of the elongated suture body in a second direction opposite the first direction. In specific embodiments, a bi-directional suture can be formed. More specifically, the elongated suture body can include first and second longitudinal portions. Step 704 can include forming a first group of the heat-contact mediated retainers that extend from and along the first longitudinal portion, so that the first group of heat-contact mediated retainers substantially yield to motion of the elongated suture body within the tissue when the elongated suture body is drawn in a first direction and resist motion of the elongated suture body in a second direction opposite the first direction. Step 704 can also include forming a second group of the heat-contact mediated retainers that extend from and

along the second longitudinal portion, so that the second group of heat-contact mediated retainers substantially yield to motion of the elongated suture body within the tissue when the elongated suture body is drawn in the second direction and resist motion of the elongated suture body in the first direction.

[0074] The elongated suture bodies 202 can be produced by any suitable method, including without limitation injection molding, extrusion, and so forth. The elongated suture bodies 202 can have a monofilament structure, or a braided structure. As explained above, a braided suture refers to multifilamentary suture thread, where the filaments in such suture threads are typically braided, twisted, or woven together. An advantage of embodiments of the present invention is that the retainers 204 can be formed on such multifilament type sutures, whereas cutting into such types of sutures (to form retainers in a conventional manner) may be difficult if not impossible due to the small size of individual strands in the filament.

[0075] A suture 200, including the suture body 202 and heat-contact mediated retainers 204, can be made of any suitable biocompatible material, and may be further treated with any suitable biocompatible material, whether to enhance the strength, resilience, longevity, or other qualities of the suture, or to equip the sutures to fulfill additional functions besides joining tissues together, repositioning tissues, or attaching foreign elements to tissues.

[0076] In a specific embodiment of the present invention a composite suture filament is created by co-extruding two materials to form a co-extruded elongated suture body having a core portion made of a first or inner material and outer portion formed of a second or outer material. The inner material is preferably selected such that it has excellent tensile and elastic properties and the outer material is selected to provide for the formation of heat-contact mediated retainers having a desired stiffness. In a specific embodiment the outer material has a higher elastic constant than the inner material to allow relatively stiff retainers to be formed by temporarily contacting the outer material with one or more heated elements to form heat-contacted mediated retainers. The outer material may also have a larger plastic region than the inner material to allow for easier permanent deformation of the outer material. The inner material is preferably more elastic than the outer material so that the suture having heat-contact mediated retainers has an enhanced combination of retainer features, suture

flexibility and tensile strength compared to a similar suture formed by cutting retainers from a single-material filament.

[0077] The sutures 200 described herein may also incorporate materials that further promote tissue engagement. For example, forming the sutures 200 of tissue engagement-promoting materials can enhance the ability of the sutures to stay in place. One such class of tissue engagement-promoting materials are porous polymers that can be extruded to form suture bodies, including both microporous polymers and polymers that can be extruded with bubbles (whether bioabsorbable or nonbioabsorbable). Sutures 200 synthesized with such materials can have a three-dimensional lattice structure that increases tissue engagement surface area and permits tissue infiltration into the suture body itself, thus having a primary structure that promotes successful suture use. Moreover, by optimizing pore size, fibroblast ingrowth can be encouraged, further facilitating anchoring of the retainers 204 in the tissue. Alternatively profibrotic coatings or agents may be used to promote more fibrous tissue encapsulation of the retainers 204 and therefore better engagement. Exemplary profibrotic materials, which can be used to form retainers 204 and/or which can be applied to retainers 204, to promote tissue growth, are disclosed in U.S. Patent No. 7,166,570, entitled "Medical implants and fibrosis-inducing agents," which is incorporated herein by reference.

[0078] One such microporous polymer is ePTFE (expanded polytetrafluoroethylene). Self-retaining sutures incorporating ePTFE (and related microporous materials) are well-suited to uses requiring a strong and permanent lift (such as breast lifts, face lifts, and other tissue repositioning procedures), as tissue infiltration of the suture results in improved fixation and engraftment of the suture and the surrounding tissue thus providing superior hold and greater longevity of the lift.

[0079] Additionally, self-retaining sutures described herein may be provided with compositions to promote healing and prevent undesirable effects such as scar formation, infection, pain, and so forth. This can be accomplished in a variety of manners, including for example: (a) by directly affixing to the suture a formulation (e.g., by either spraying the suture with a polymer/drug film, or by dipping the suture into a polymer/drug solution), (b) by coating the suture with a substance such as a hydrogel which will in turn absorb the composition, (c) by interweaving formulation-coated thread (or the polymer itself formed into a thread) into the suture structure in the case of multi-filamentary sutures, (d) by inserting the suture into a sleeve or mesh

which is comprised of, or coated with, a formulation, or (e) constructing the suture itself with a composition. Such compositions may include without limitation anti-proliferative agents, anti-angiogenic agents, anti-infective agents, fibrosis-inducing agents, anti-scarring agents, lubricious agents, echogenic agents, anti-inflammatory agents, cell cycle inhibitors, analgesics, and anti-microtubule agents. For example, a composition can be applied to the suture before the retainers are formed, so that when the retainers engage, the engaging surface is substantially free of the coating. In this way, tissue being sutured contacts a coated surface of the suture as the suture is introduced, but when the retainer engages, a non-coated surface of the retainer contacts the tissue. Alternatively, the suture may be coated after or during formation of retainers on the suture if, for example, a fully-coated rather than selectively-coated suture is desired. In yet another alternative, a suture may be selectively coated either during or after formation of retainers by exposing only selected portions of the suture to the coating. The particular purpose to which the suture is to be put or the composition may determine whether a fully-coated or selectively-coated suture is appropriate; for example, with lubricious coatings, it may be desirable to selectively coat the suture, leaving, for instance, the tissue-engaging surfaces of the sutures uncoated in order to prevent the tissue engagement function of those surfaces from being impaired. On the other hand, coatings such as those comprising such compounds as anti-infective agents may suitably be applied to the entire suture, while coatings such as those comprising fibrosing agents may suitably be applied to all or part of the suture (such as the tissue-engaging surfaces). The purpose of the suture may also determine the sort of coating that is applied to the suture; for example, self-retaining sutures having anti-proliferative coatings may be used in closing tumour excision sites, while self-retaining sutures with fibrosing coatings may be used in tissue repositioning procedures and those having anti-scarring coatings may be used for wound closure on the skin. As well, the structure of the suture may influence the choice and extent of coating; for example, sutures having an expanded segment may include a fibrosis-inducing composition on the expanded segment to further secure the segment in position in the tissue. Coatings may also include a plurality of compositions either together or on different portions of the suture, where the multiple compositions can be selected either for different purposes (such as combinations of analgesics, anti-infective and anti-scarring agents) or for their synergistic effects.

D. Clinical Uses

[0080] In addition to the general wound closure and soft tissue repair applications described in the preceding sections, self-retaining sutures can be used in a variety of other indications.

[0081] Self-retaining sutures described herein may be used in various dental procedures, i.e., oral and maxillofacial surgical procedures and thus may be referred to as “self-retaining dental sutures.” The above-mentioned procedures include, but are not limited to, oral surgery (e.g., removal of impacted or broken teeth), surgery to provide bone augmentation, surgery to repair dentofacial deformities, repair following trauma (e.g., facial bone fractures and injuries), surgical treatment of odontogenic and non-odontogenic tumors, reconstructive surgeries, repair of cleft lip or cleft palate, congenital craniofacial deformities, and esthetic facial surgery. Self-retaining dental sutures may be degradable or non-degradable, and may typically range in size from USP 2-0 to USP 6-0.

[0082] Self-retaining sutures described herein may also be used in tissue repositioning surgical procedures and thus may be referred to as “self-retaining tissue repositioning sutures”. Such surgical procedures include, without limitation, face lifts, neck lifts, brow lifts, thigh lifts, and breast lifts. Self-retaining sutures used in tissue repositioning procedures may vary depending on the tissue being repositioned; for example, sutures with larger and further spaced-apart retainers may be suitably employed with relatively soft tissues such as fatty tissues.

[0083] Self-retaining sutures described herein may also be used in microsurgical procedures that are performed under a surgical microscope (and thus may be referred to as “self-retaining microsutures”). Such surgical procedures include, but are not limited to, reattachment and repair of peripheral nerves, spinal microsurgery, microsurgery of the hand, various plastic microsurgical procedures (e.g., facial reconstruction), microsurgery of the male or female reproductive systems, and various types of reconstructive microsurgery. Microsurgical reconstruction is used for complex reconstructive surgery problems when other options such as primary closure, healing by secondary intention, skin grafting, local flap transfer, and distant flap transfer are not adequate. Self-retaining microsutures have a very small caliber, often as small as USP

9-0 or USP 10-0, and may have an attached needle of corresponding size. They may be degradable or non-degradable.

[0084] Self-retaining sutures as described herein may be used in similarly small caliber ranges for ophthalmic surgical procedures and thus may be referred to as “ophthalmic self-retaining sutures”. Such procedures include but are not limited to keratoplasty, cataract, and vitreous retinal microsurgical procedures. Ophthalmic self-retaining sutures may be degradable or non-degradable, and have an attached needle of correspondingly-small caliber.

[0085] Self-retaining sutures can be used in a variety of veterinary applications for a wide number of surgical and traumatic purposes in animal health.

[0086] Although the present invention has been shown and described in detail with regard to only a few exemplary embodiments of the invention, it should be understood by those skilled in the art that it is not intended to limit. Various modifications, omissions, and additions may be made to the disclosed embodiments without materially departing from the novel teachings and advantages, particularly in light of the foregoing teachings.

What is claimed is:

1. A method of forming a suture to be used in a surgical procedure applied to tissue, comprising:

(a) providing an elongated suture body; and

(b) forming a plurality of heat-contact mediated retainers on the elongated suture body by temporarily contacting the elongated suture body with one or more heated element;

wherein the elongated suture body includes a first longitudinal portions; and a first group of the heat-contact mediated retainers extend from the first longitudinal portion substantially yield to motion of the elongated suture body within the tissue when the elongated suture body is drawn in a first direction and resist motion of the elongated suture body in a second direction opposite the first direction.

2. The method of claim 1, wherein step (b) includes:

(b.1) moving at least one of the elongated suture body and said heated element, relative to one another, so that said heated element comes in contact with the elongated suture body and melts a portion of the elongated suture body.

3. The method of claim 1, wherein the temporarily contacting of the elongated suture body with the one or more heated element at step (b) is performed such that the retainers are formed at acute angles relative to the suture body and directed toward a first end of the elongated suture body, so that the retainers substantially yield to motion of the elongated suture body within the tissue when the elongated suture body is drawn at a second end of the elongated suture body and resist motion of the elongated suture body within tissue when the elongated suture body is drawn at the first end.

4. The method of claim 1, wherein step (b) includes temporarily contacting the elongated suture body with a plurality of the heated elements, to thereby form a plurality of the retainers simultaneously.

5. The method of claim 4, wherein at least some of the plurality of heated elements are heat conductive elements that extend from a common heat conductive body, and where the heat conductive elements are heated when the heat conductive body is heated.

6. The method of claim 1, wherein step (b) includes:

(b.1) moving said heated element toward the elongated suture body, while the elongated suture body is not moving, so that said heated element comes in contact with the elongated suture body and melts a portion of the elongated suture body; and

(b.2) moving the heated element away from the elongated suture body so that said heated element is no longer in contact with the elongated suture body, and so that at least some of the melted portion of the elongated suture body protrudes from the elongated suture body and forms said retainer when cooled.

7. The method of claim 1, wherein step (b) includes:

(b.1) moving the elongated suture body in a first forming direction;

(b.2) while the elongated suture body is being moved in the first forming direction, moving said heated element toward the elongated suture body in a second forming direction, that is at an angle relative to the first forming direction, so that said heated element comes in contact with the elongated suture body and melts a portion of the elongated suture body; and

(b.3) moving the heated element away from the elongated suture body so that said heated element is no longer in contact with the elongated suture body, and so that at least some of the melted portion of the elongated suture body protrudes from the elongated suture body and forms said retainer when cooled.

8. The method of claim 7, wherein the second forming direction is generally perpendicular to the first forming direction.
9. The method of claim 7, wherein the second forming direction is at an obtuse angle or an acute angle relative to the first forming direction.
10. The method of claim 1, wherein step (b) includes controlling at least one of speed and acceleration at which the heated element comes in contact with or withdrawn from the elongated suture body to affect at least one of shape and size of the retainer formed using the heated element.
11. The method of claim 1, wherein step (b) includes controlling a duration of contact between the heated element and the elongated suture body to affect a shape and/or size of the retainer formed using the heated element.
12. The method of claim 1, wherein step (b) includes controlling a pressure at which the heated element comes in contact with the elongated suture body to affect a shape and/or size of the retainer formed using the heated element.
13. The method of claim 1, includes controlling a temperature of the heated element to affect a shape and/or size of the retainer formed using the heated element.
14. A method of forming a suture to be used in a surgical procedure applied to tissue, comprising:
 - providing an elongated suture body;
 - engaging the elongated suture body with a heated element to melt a portion of the elongated suture body;
 - pulling on the heated element to form an elongated molten portion of the suture body extending outward from the suture body; and

disengaging the heated element from the elongated suture body so that the elongated molten portion protrudes and forms a retainer when cooled;

wherein the elongated suture body includes a first longitudinal portions; and a first group of the heat-contact mediated retainers extend from the first longitudinal portion substantially yield to motion of the elongated suture body within the tissue when the elongated suture body is drawn in a first direction and resist motion of the elongated suture body in a second direction opposite the first direction.

15. The method of claim 14, wherein the elongated suture body comprises multiple filaments that are one of braided, twisted, or woven together.

16. A suture that can be used during a procedure applied to tissue, comprising:

an elongated suture body; and a plurality of heat-contact mediated retainers arranged along at least a portion of the elongated suture body and extending outward from the elongated suture body, wherein the elongated suture body includes a first longitudinal portions; and a first group of the heat-contact mediated retainers extend from the first longitudinal portion substantially yield to motion of the elongated suture body within the tissue when the elongated suture body is drawn in a first direction and resist motion of the elongated suture body in a second direction opposite the first direction.

17. The suture of claim 16, wherein the heat-contact mediated retainers are formed of heated and reformed portions of the elongated suture body.

18. The suture of claim 16, wherein the heat-contact mediated retainers are treated to increase their stiffness and strength.

19. The suture of claim 16, wherein: the elongated suture body further includes a second longitudinal portion; and a second group of the heat-contact mediated retainers extend from the second longitudinal portion and substantially yield to motion of the

elongated suture body within the tissue when the elongated suture body is drawn in the second direction and resist motion of the elongated suture body in the first direction.

20. The suture of claim 16, wherein each heat-contact mediated retainer comprises a retainer body projecting from the elongated suture body and a retainer end adapted to penetrate tissue.

21. A method of forming a suture to be used in a surgical procedure applied to tissue, comprising:

(a) providing a dual extruded elongated suture body including a core portion formed of a first material, and an outer portion formed of a second material, wherein the second material has a higher elastic constant and/or a larger plastic zone than the first material; and

(b) forming retainers on the elongated suture body by temporarily contacting the outer material of the elongated suture body with one or more heated element and pulling the heated element away from the suture body to form an elongated molten portion of the suture body extending outward from the suture body;

wherein the elongated suture body includes a first longitudinal portions; and a first group of the heat-contact mediated retainers extend from the first longitudinal portion substantially yield to motion of the elongated suture body within the tissue when the elongated suture body is drawn in a first direction and resist motion of the elongated suture body in a second direction opposite the first direction.

22. A suture to be used in a surgical procedure applied to tissue, comprising:

a dual extruded elongated suture body including a core portion formed of a first material, and an outer portion formed of a second material, wherein the second material has a higher elastic constant and/or a larger plastic zone than the first material; and

a plurality of heat-contact mediated retainers, arranged along at least a portion of the elongated suture body, and formed of the second material;

wherein the elongated suture body includes a first longitudinal portions; and a first group of the heat-contact mediated retainers extend from the first longitudinal portion substantially yield to motion of the elongated suture body within the tissue when the elongated suture body is drawn in a first direction and resist motion of the elongated suture body in a second direction opposite the first direction.

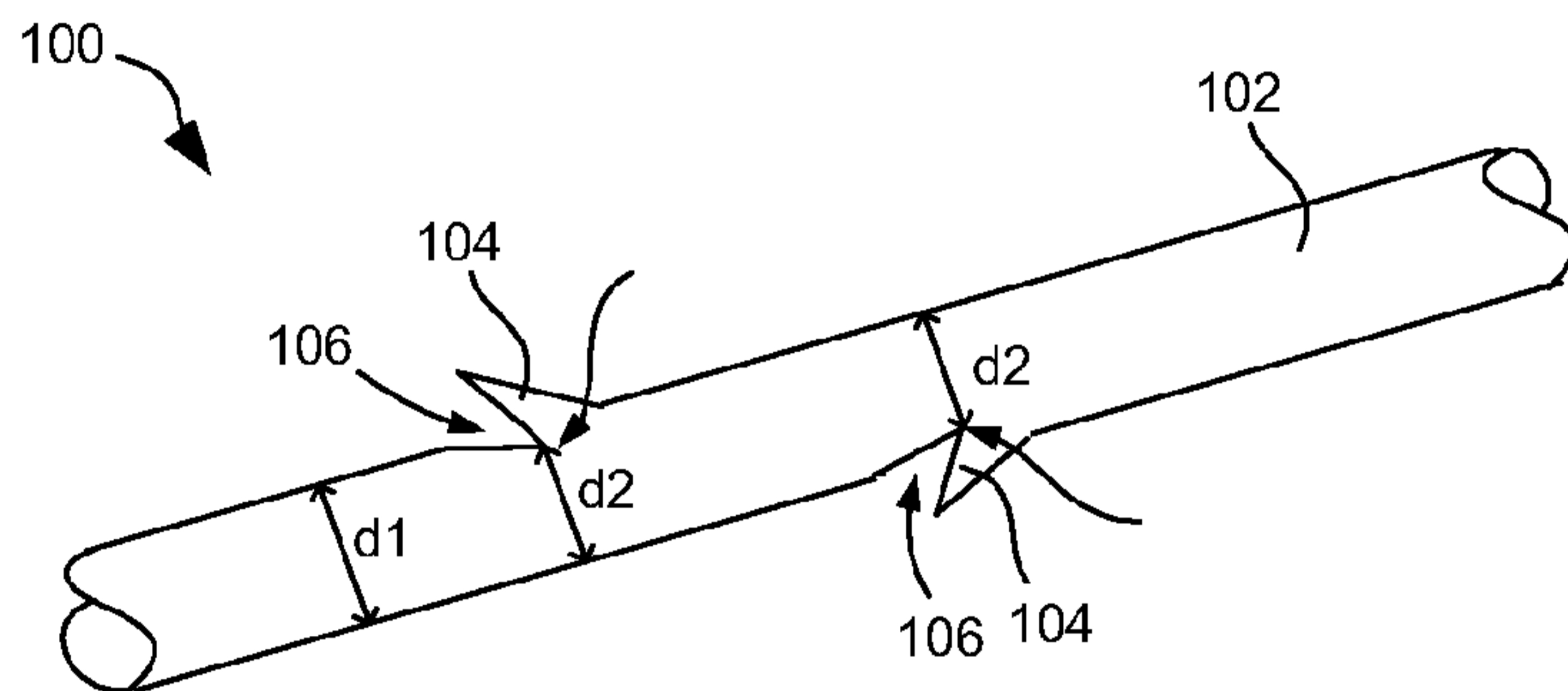

FIG. 1 (Prior Art)

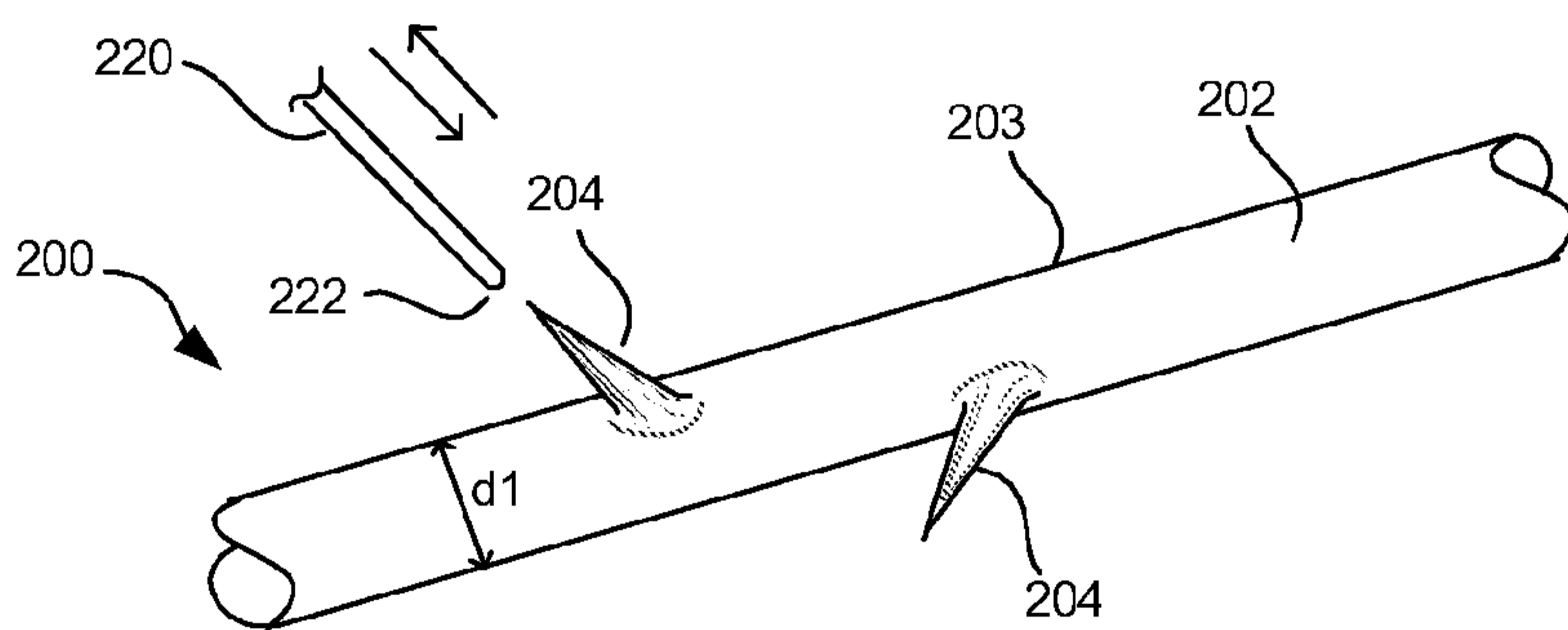

FIG. 2A

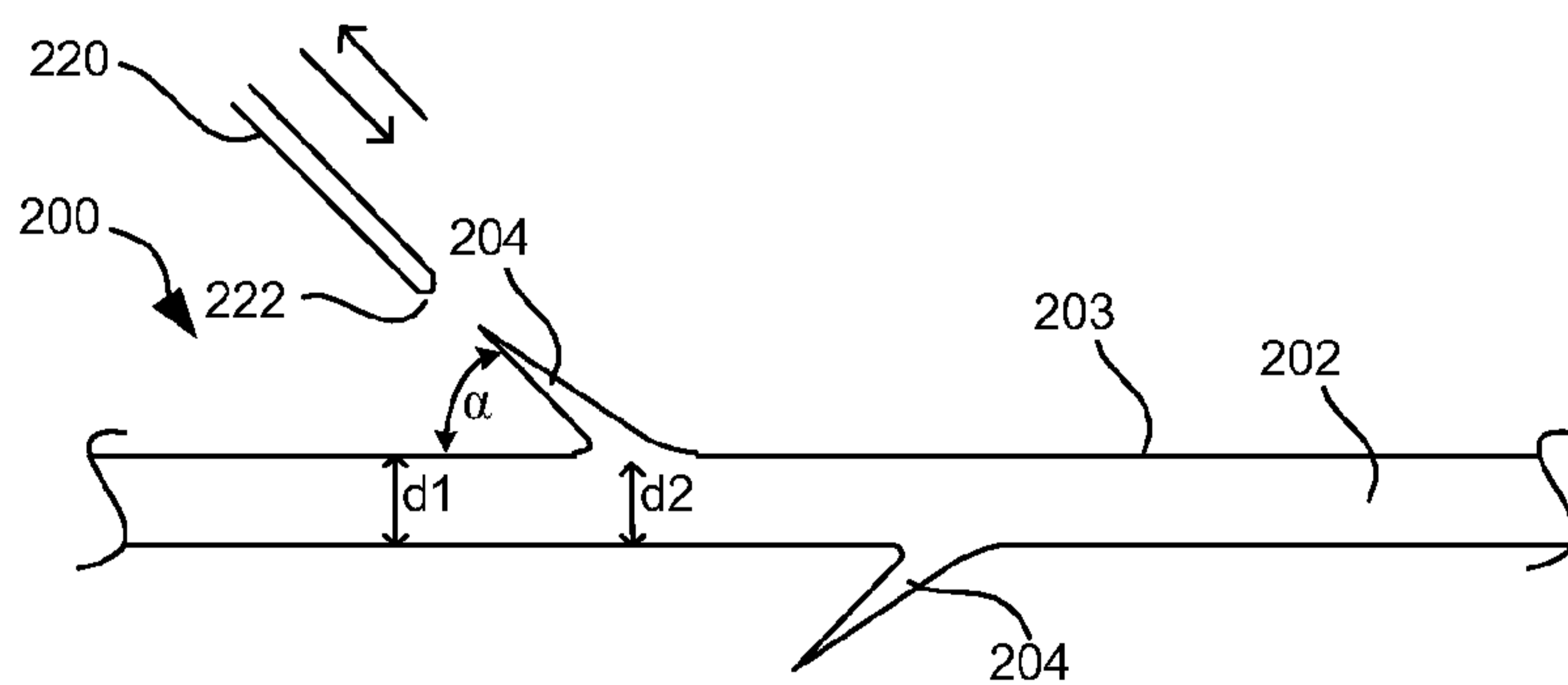

FIG. 2B

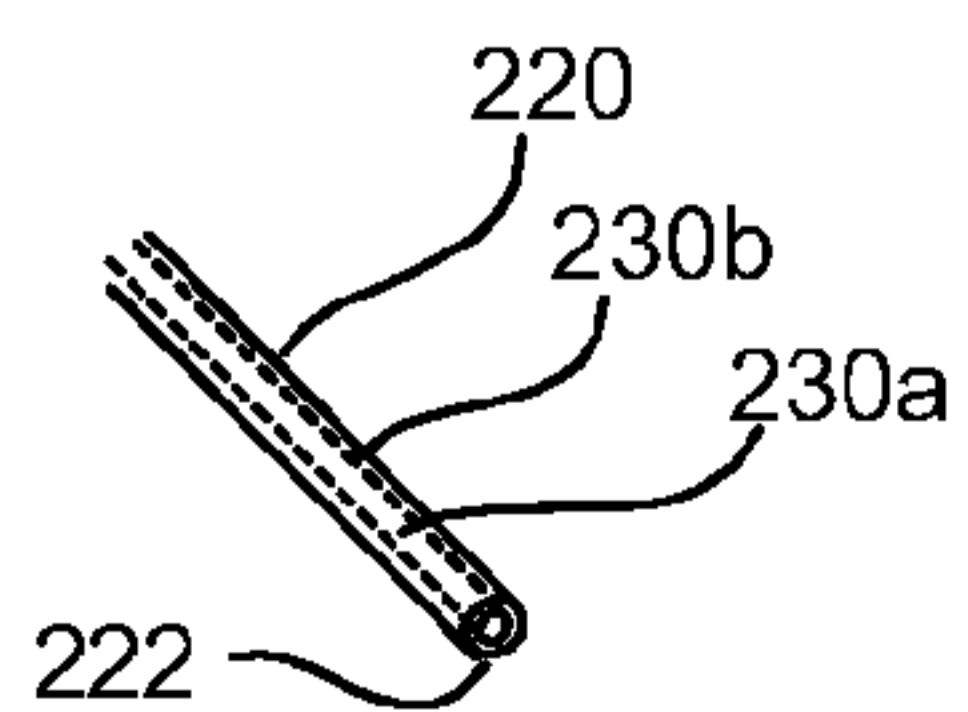

FIG. 2C

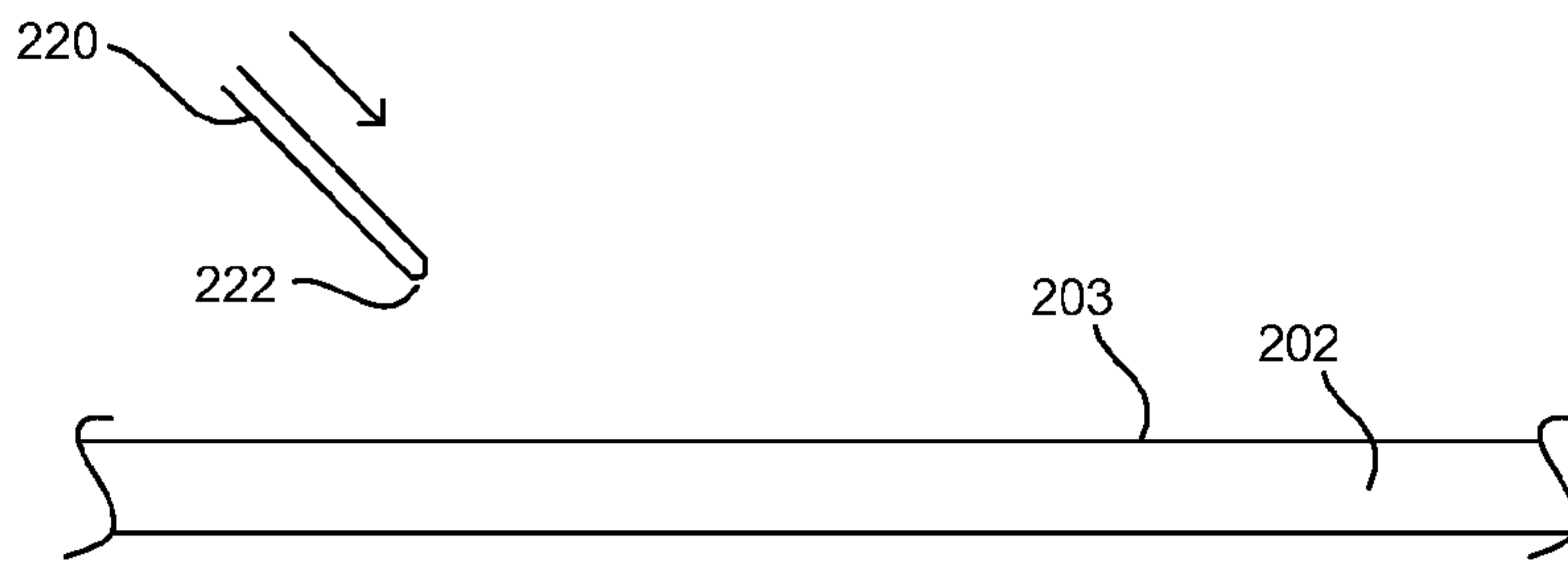

FIG. 3A

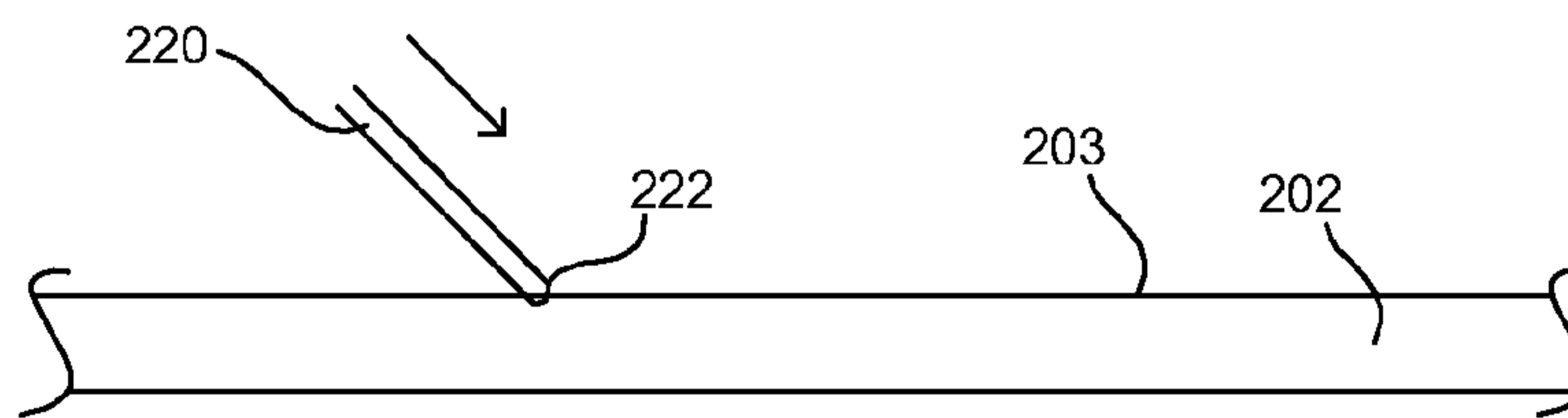

FIG. 3B

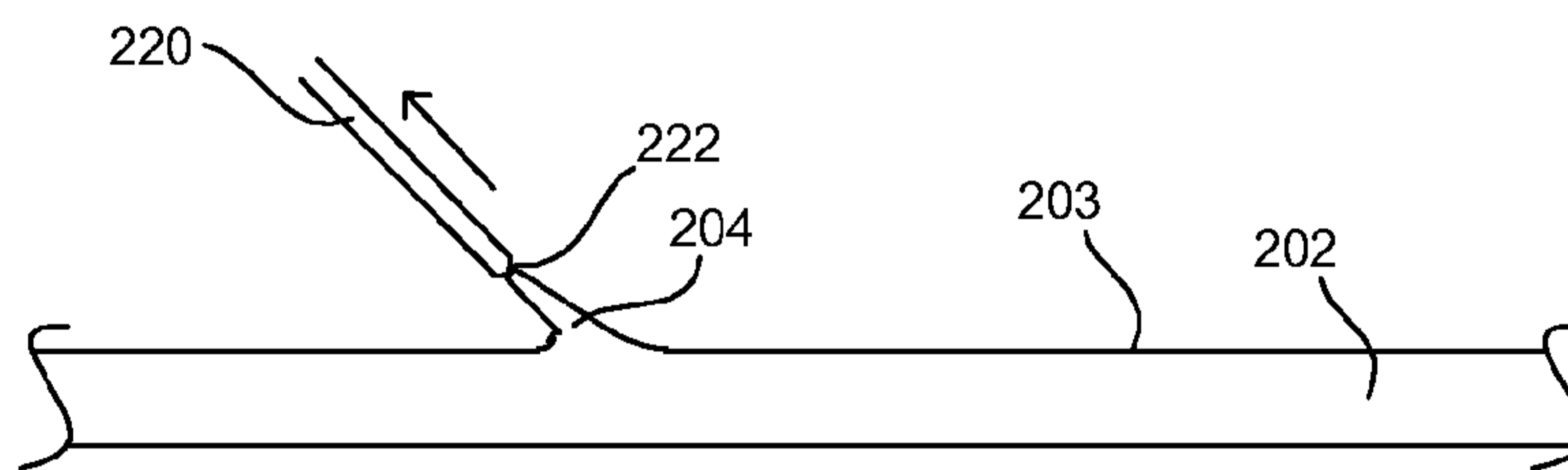

FIG. 3C

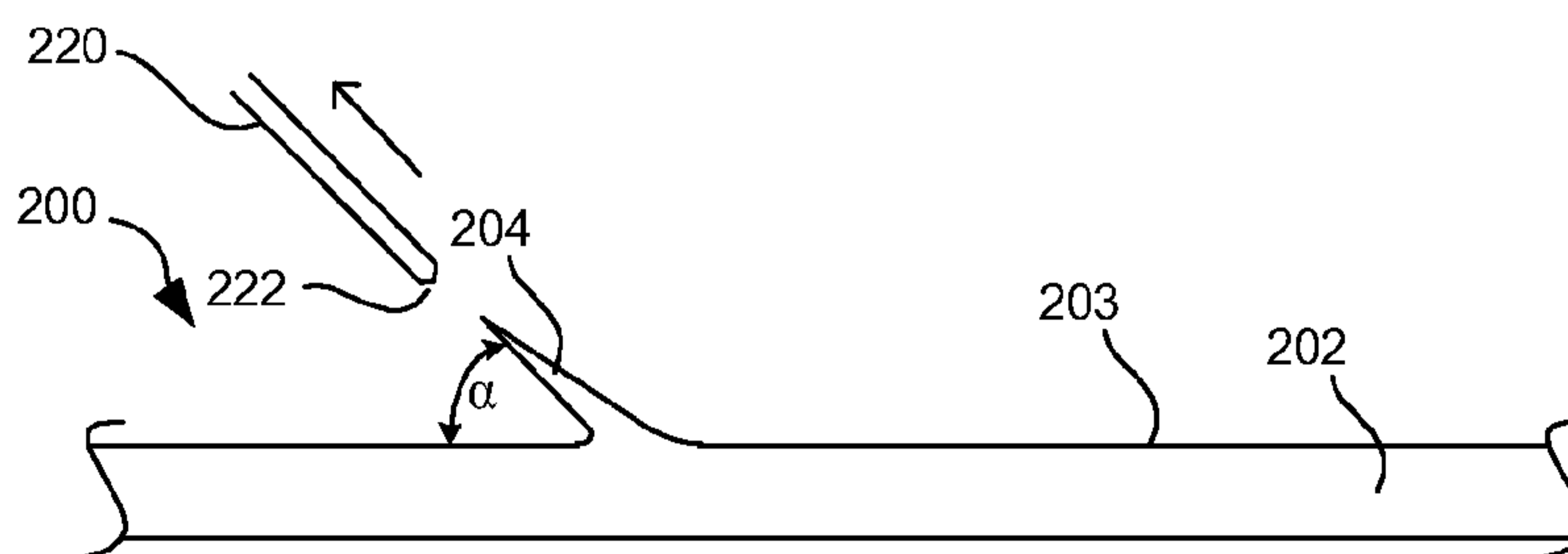

FIG. 3D

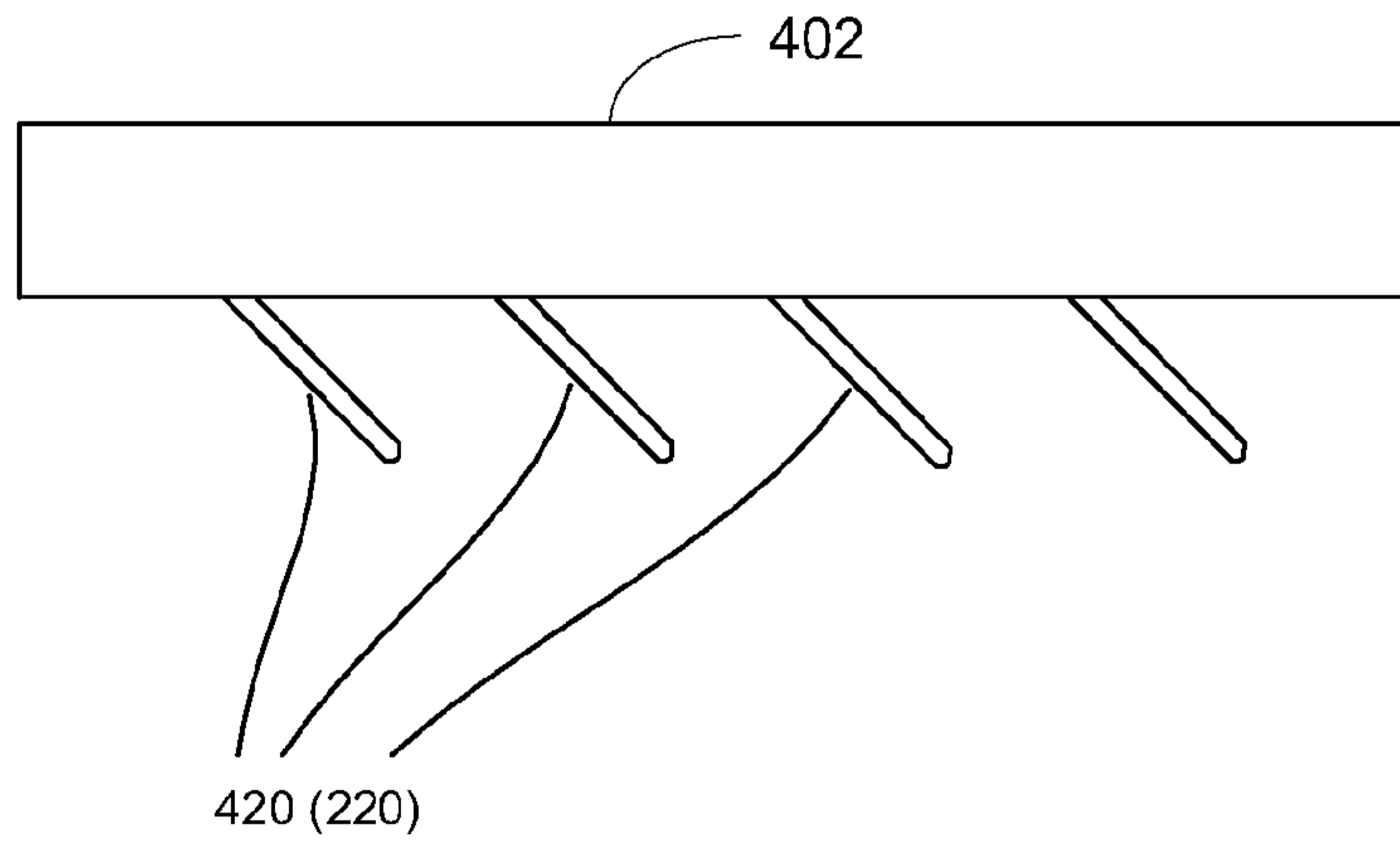

FIG. 4

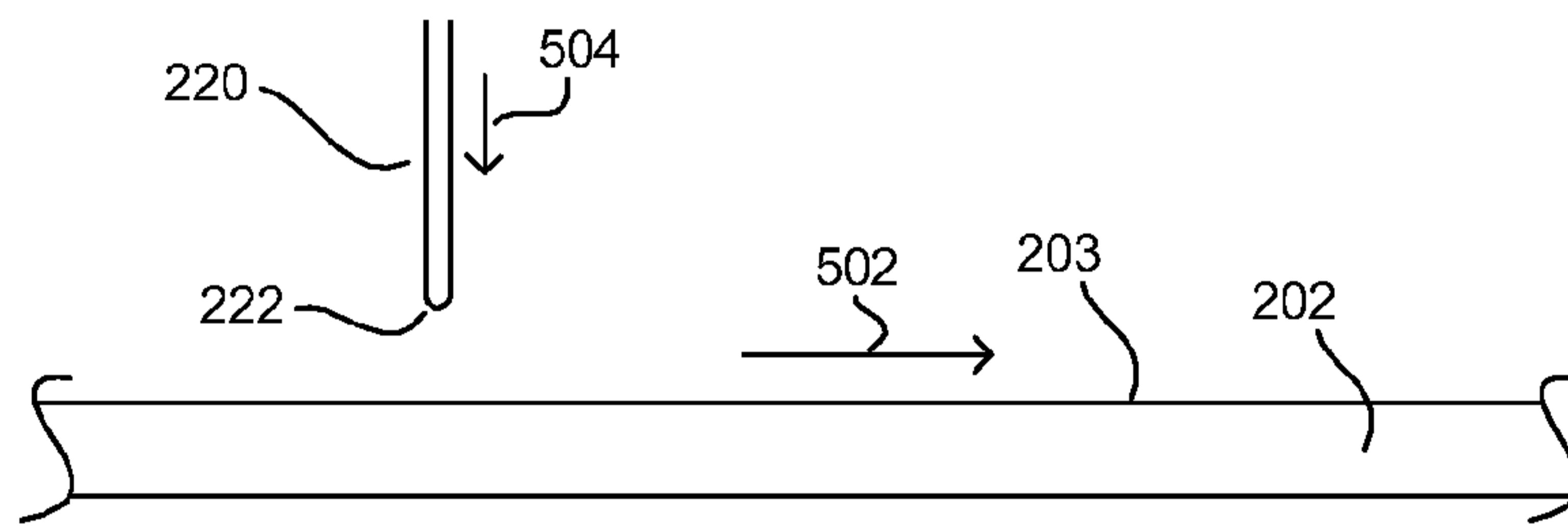

FIG. 5A

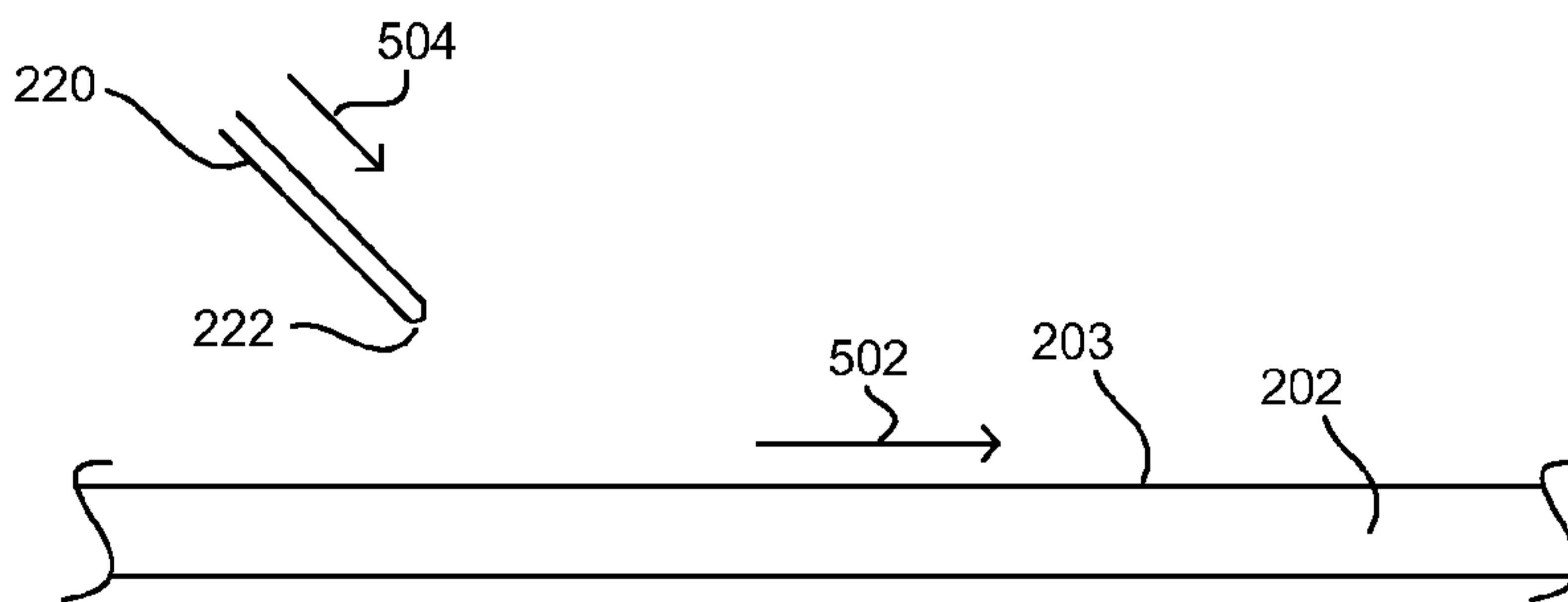

FIG. 5B

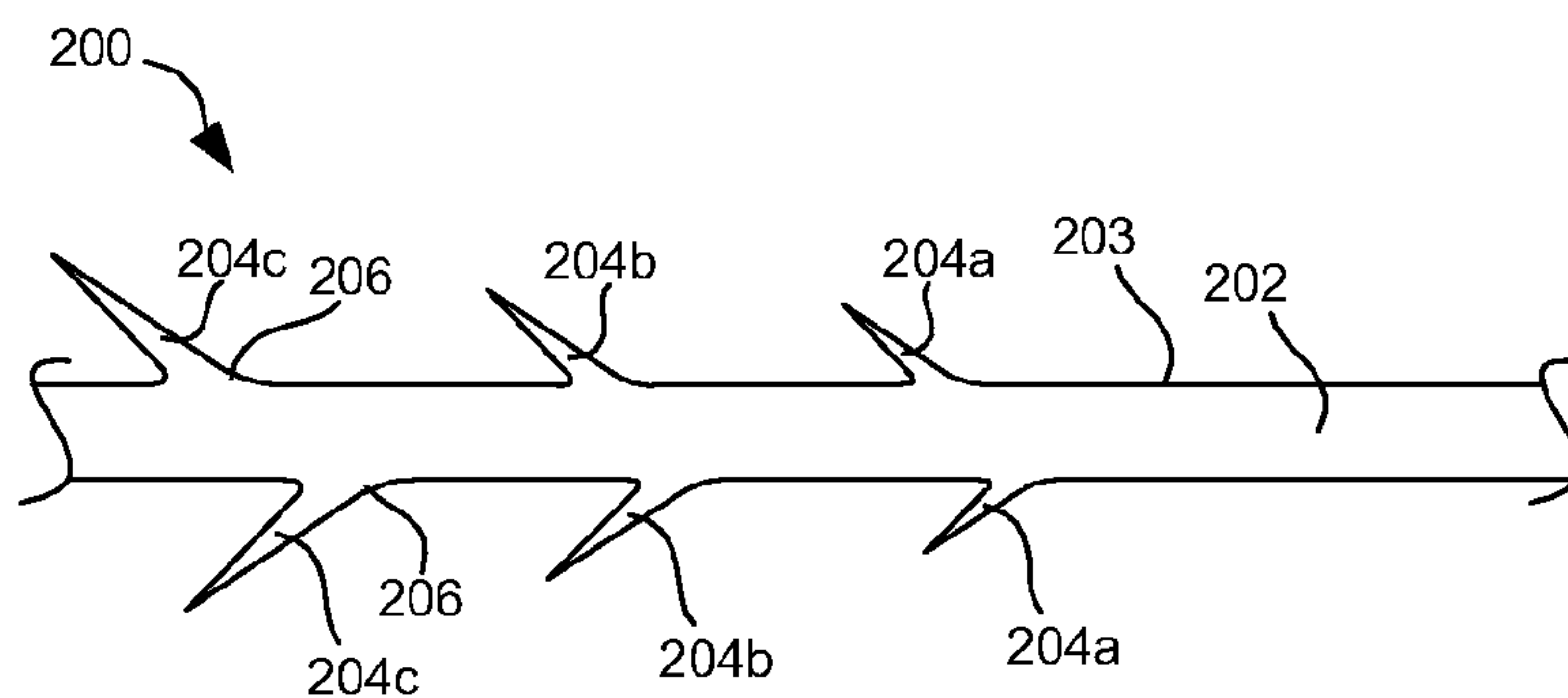

FIG. 6

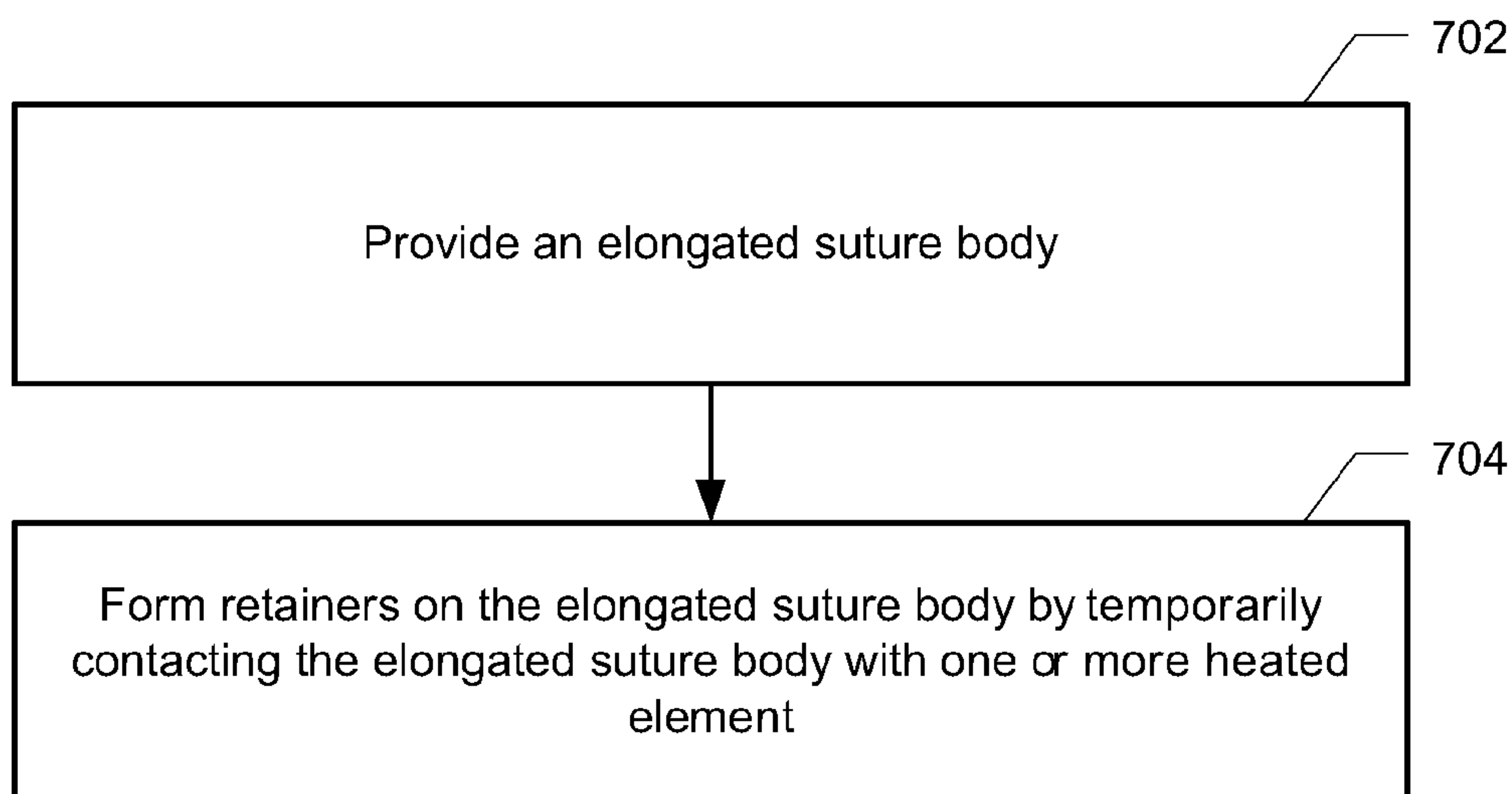
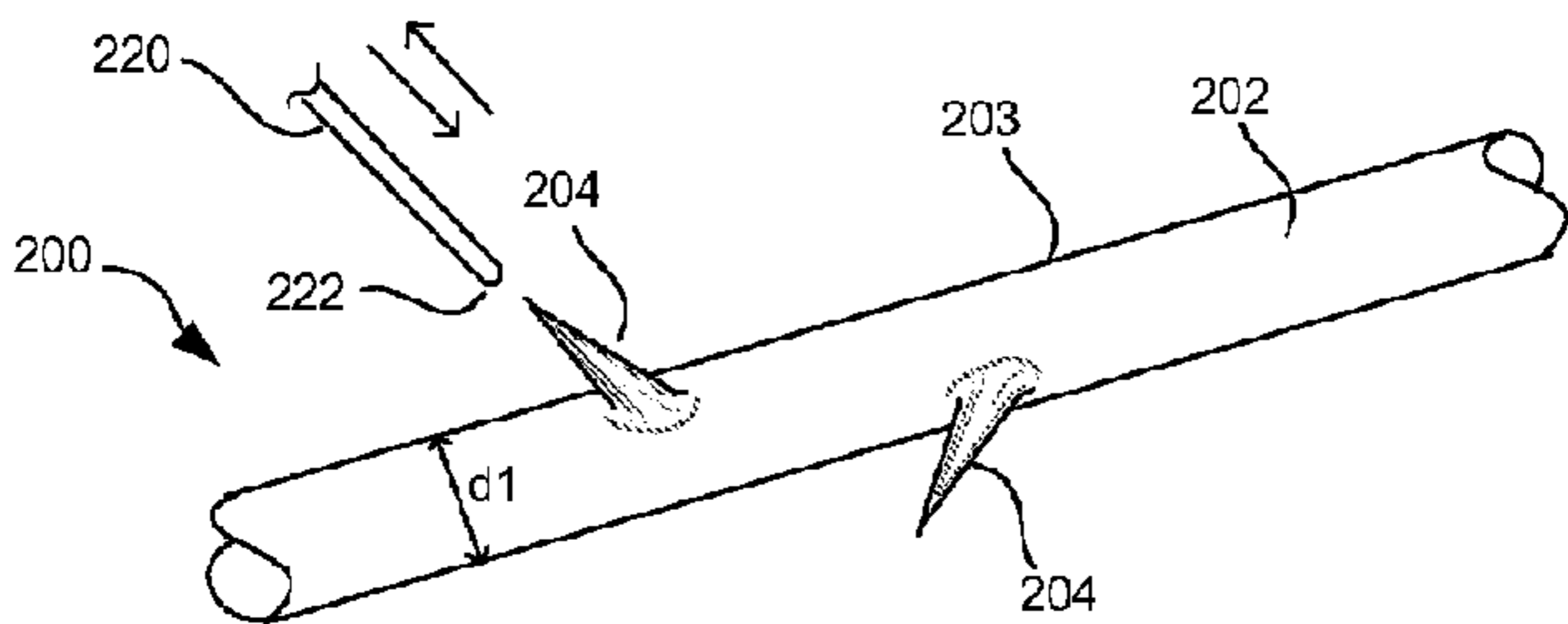
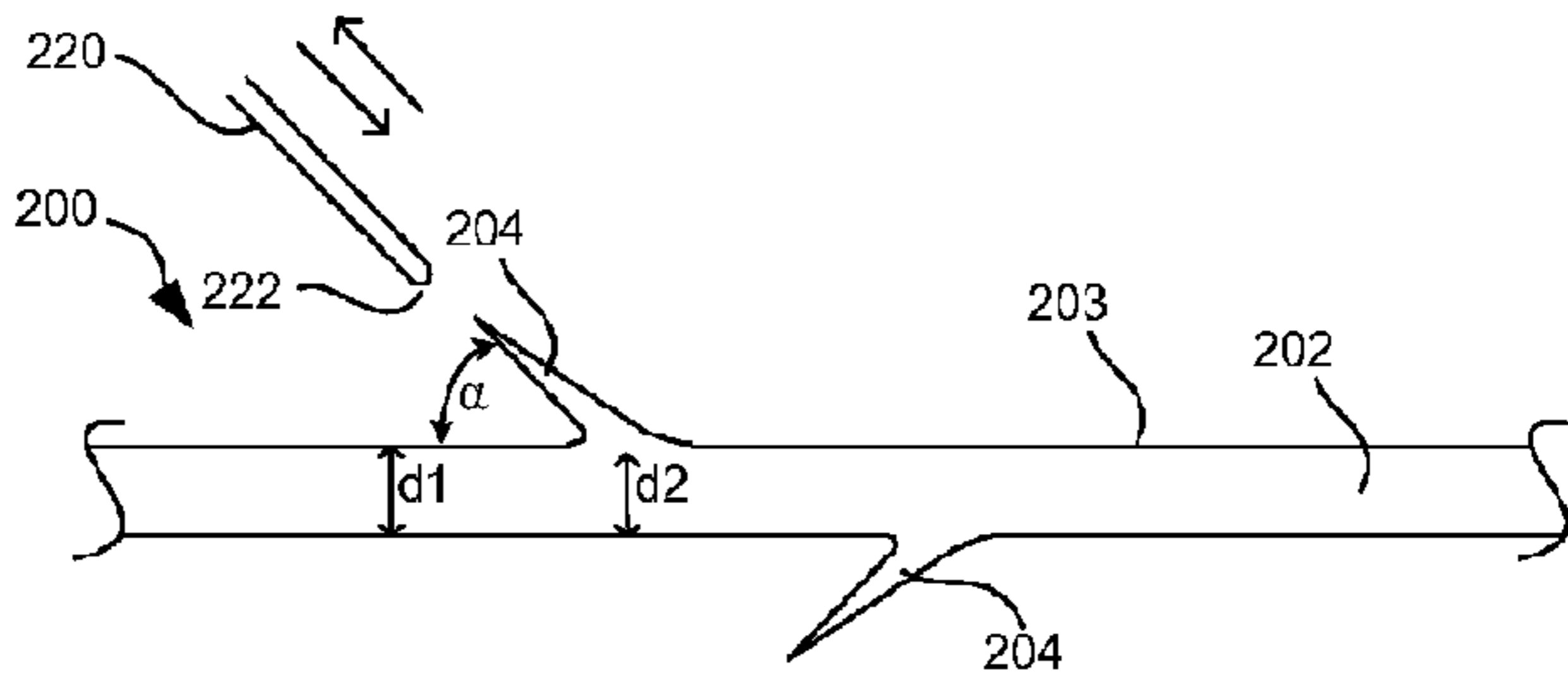

FIG. 7



A



B

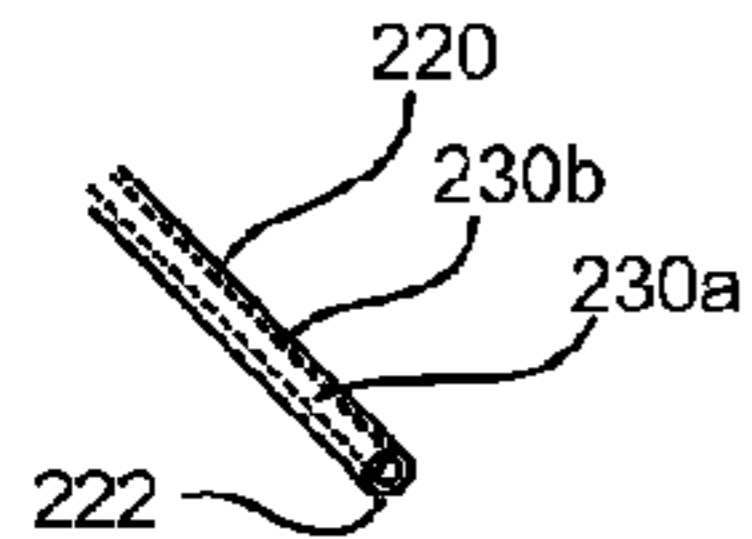

C