



US 20060172245A1

(19) **United States**

(12) **Patent Application Publication**

Hu et al.

(10) **Pub. No.: US 2006/0172245 A1**

(43) **Pub. Date: Aug. 3, 2006**

(54) **GAS BURNER WITH THERMOELECTRIC GENERATOR**

(52) **U.S. Cl. 431/354; 431/80**

(76) **Inventors: Caroline K. Hu, Novi, MI (US); Kevin Z. Hu, Novi, MI (US)**

(57) **ABSTRACT**

Correspondence Address:
Haoran Hu
23901 Broadmoor Park Lane
Novi, MI 48374 (US)

(21) **Appl. No.: 11/045,981**

(22) **Filed: Jan. 31, 2005**

Publication Classification

(51) **Int. Cl. F23D 14/62 (2006.01)**

A gas burner with thermoelectric unit installed inside the burner head to generate electricity with waste heat energy. Gas flame at the edge of the burner head creates high temperature source (hot side) for the thermoelectric unit. A heat sink is installed inside the burner head and cooled by the fuel mixture. Electricity is generated by the thermoelectric unit when the gas burner is in operation. The electricity generated by the thermoelectric unit can be used to power electric devices.

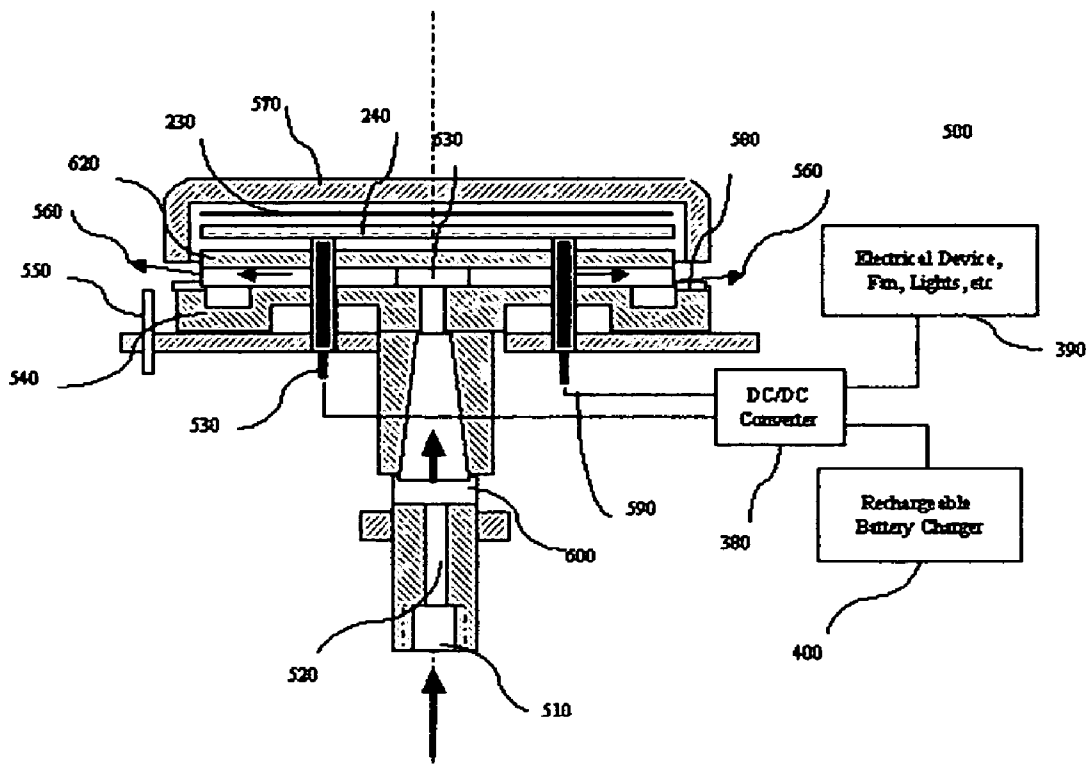

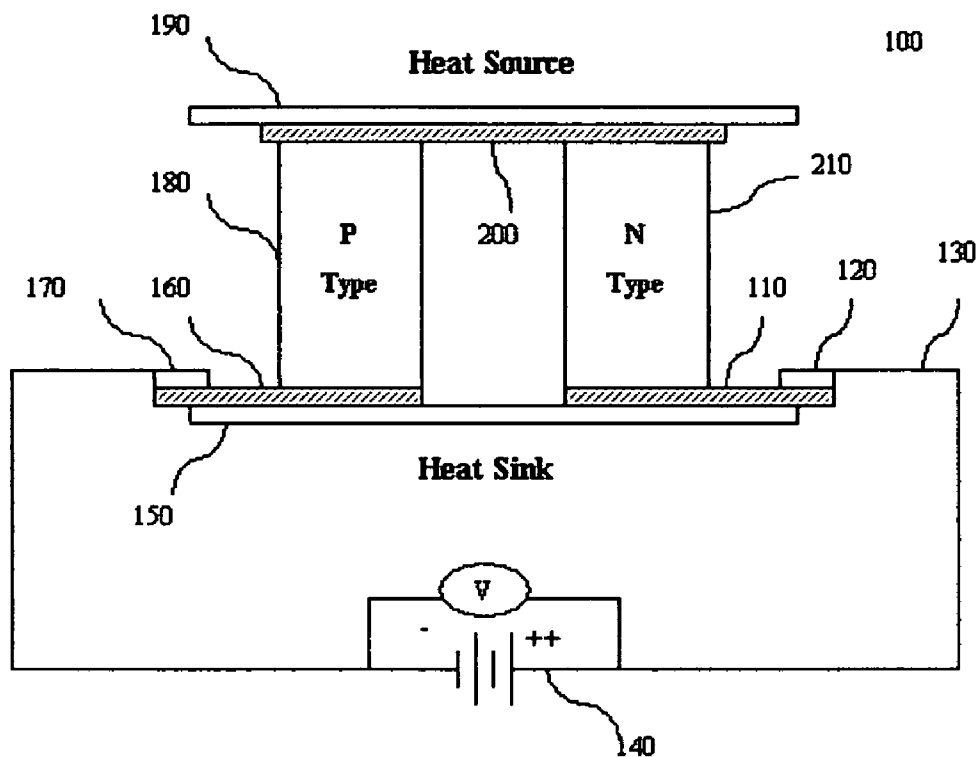

Fig 1

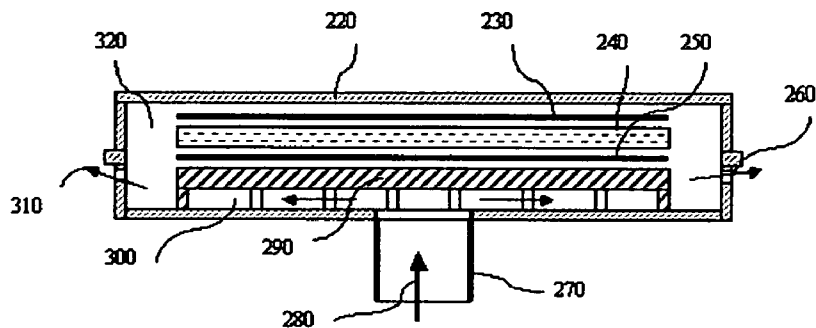

Fig 2A

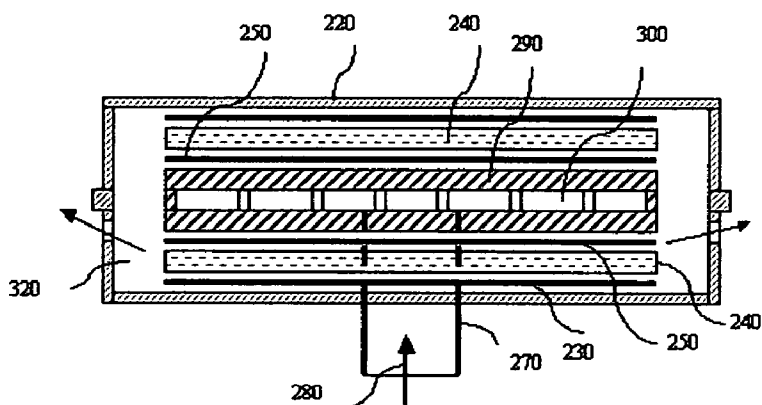

Fig 2B

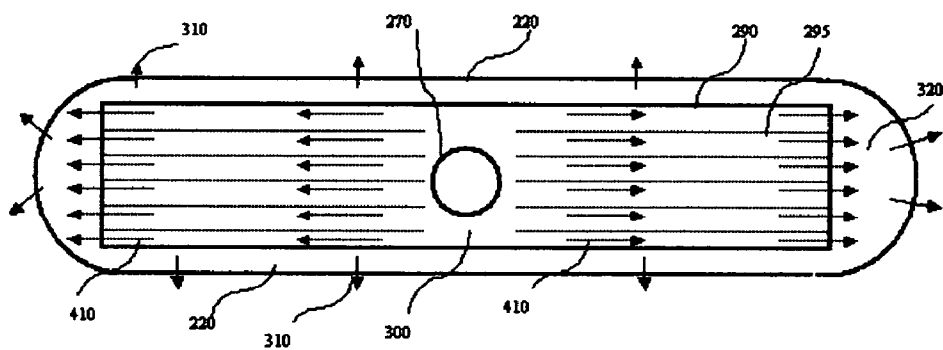

Fig 3A

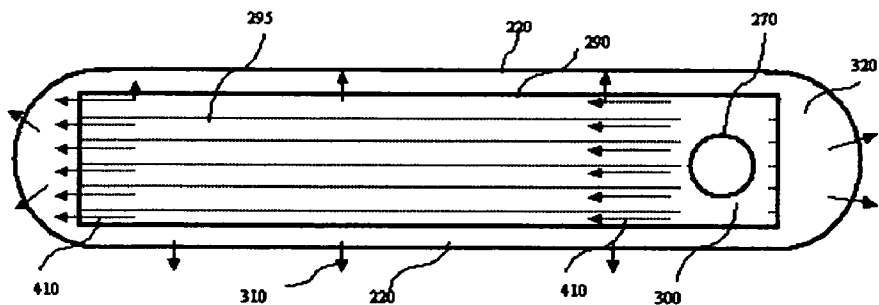

Fig 3B

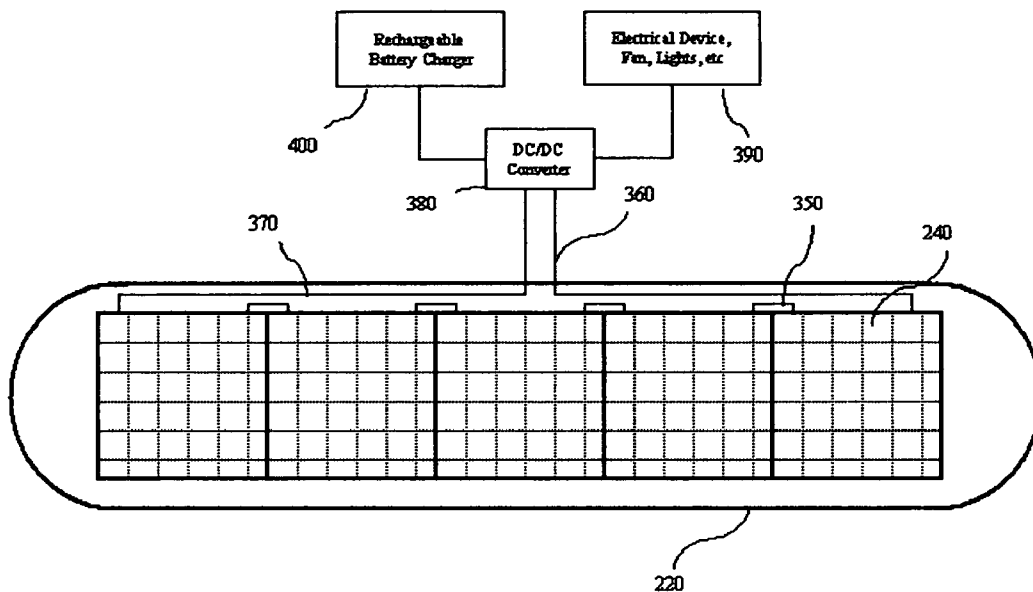

Fig 4

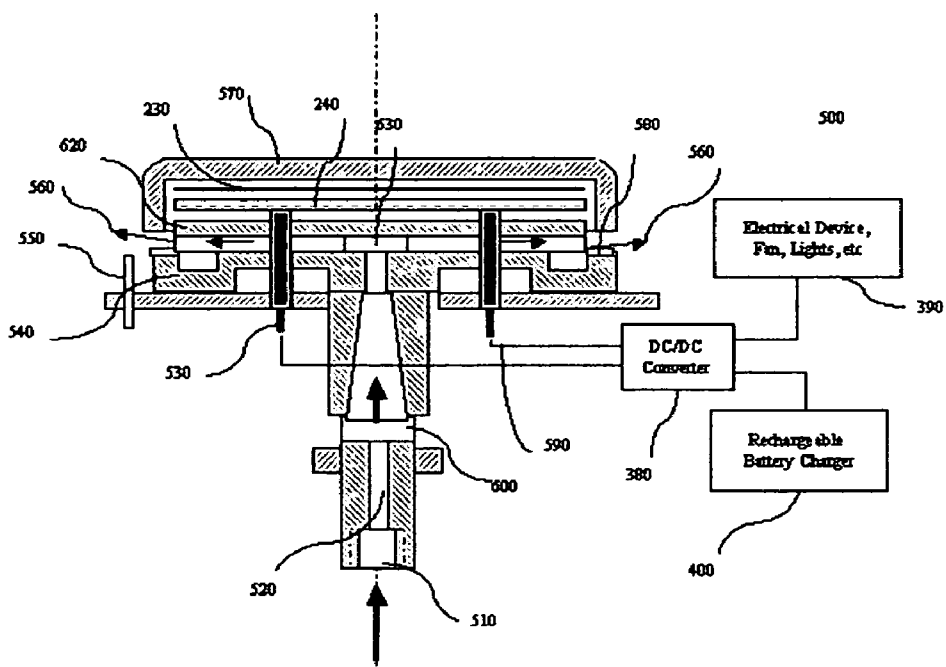

Fig 5A

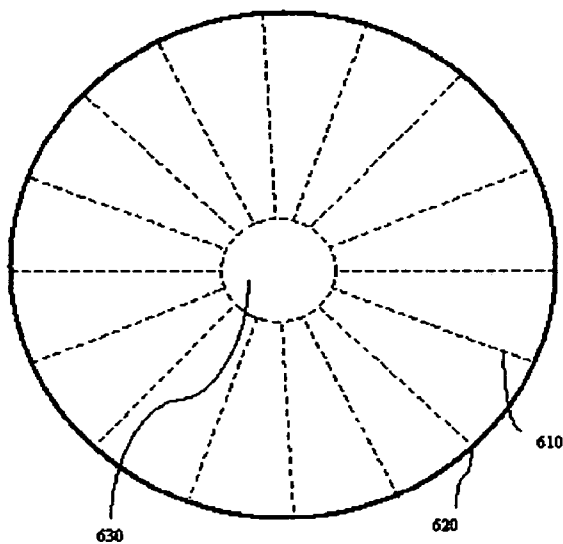

Fig 5B

GAS BURNER WITH THERMOELECTRIC GENERATOR

BACKGROUND OF INVENTION

[0001] Gas burner converts gaseous fuels into thermal energy. Utilizing waste thermal energy of the gas burner for electricity generation provides convenient source of electricity and energy savings. Electricity generated by the gas burner can be used to power devices such as electric fans, lights, televisions, battery chargers etc.

[0002] Major components of a typical gas burner include a gas supply head and a burner head. The gas supply head provides gaseous fuel, such as natural gas or propane to the burner head. The burner head has a mixing chamber for proper fuel/air mixing. There are slots or holes around the burner head for the formation of flame jets.

[0003] Thermoelectric modules have been commercially available for about 30 years. One of such modules is described in U.S. Pat. No. 5,892,656. It has dimensions of 75 mm×75 mm×5 mm and produces 14 Watts at operating temperature difference of 185° C.

[0004] U.S. Pat. No. 6,588,419 describes a fireplace appliance with two thermoelectric modules. The thermoelectric modules receive heat energy from the fireplace. An electric fan, powered by the thermoelectric modules, is used to cool heat sinks. U.S. Pat. No. 6,053,165 describes a stovepipe thermoelectric generator. Two thermoelectric modules are sandwiched between the stove exhaust pipe and the heat sinks.

[0005] Both systems mentioned above consume up to 50% of power generated by the thermoelectric modules to cool the heat sinks. Therefore, there is a need for a more efficient thermoelectric generator system. The present invention provides a gas burner thermoelectric generator with an internal gas cooling mechanism. This internal gas cooling mechanism eliminates the need for cooling fans and the heat sink units. Therefore, it significantly improves the overall system efficiency of the thermoelectric generator.

SUMMARY OF INVENTION

[0006] The present invention enables a gas burner to generate electricity with waste thermal energy. The invented gas burner can be installed on gas stoves, such as indoor cooking appliances or outdoor gas grills, gas furnaces, and other gas burner applications. At least one thermoelectric unit is installed inside the burner head. Gas flame at the edge of the burner head creates heat source (hot side) for the thermoelectric unit. A heat conducting plate is placed in between the thermoelectric module and the gas mixing chamber and functions as heat sink (cold side) for the thermoelectric unit. An insulation plate is inserted in between the thermoelectric unit and the burner head to control the hot side temperature. The thermoelectric unit generates electricity while the gas burner is in use.

BRIEF DESCRIPTION OF DRAWINGS

[0007] FIG. 1 shows the operating principle of the thermoelectric module.

[0008] FIGS. 2A and 2B show a gas burner with preferred embodiments of the present invention.

[0009] FIGS. 3A and 3B show example layouts of heat conducting plate of the present invention.

[0010] FIG. 4 shows an example layout of thermoelectric modules of the present invention.

[0011] FIGS. 5A and 5B show an alternate layout of gas burner with thermoelectric generator.

DETAILED DESCRIPTION

[0012] FIG. 1 is a schematic representation of electrical circuit 130 associated with thermoelectric module 100 in accordance with the present invention. Electrical circuit 130 is a typical electrical circuit associated with thermoelectric elements or thermocouples to convert heat energy into electrical energy. Electrical circuit 130, 140 generally includes two dissimilar or similar materials differing in the type of majority current carrier such as N-type thermoelectric element 210 and P-type thermoelectric element 180. Thermoelectric elements 210 and 180 are typically arranged in an alternating N-type element to P-type element serpentine configuration. In almost all thermoelectric devices, semiconductor materials with these characteristics are connected electrically in series and thermally in parallel. N-type semiconductor materials have more electrons than necessary to complete a perfect molecular lattice structure. P-type semiconductor materials have fewer electrons than necessary to complete a lattice structure. The unbalance of electrons between the N-type semiconductor material and the P-type semiconductor material, coupled with lattice vibrations, transports thermal energy. Bonding joints 110, 160, 200 can be attached to electrical interconnects 120 and 170 and to fix thermoelectric elements 210 and 180 between heat source 190 and heat sink 150. During operation, electrical power is generated if there is a temperature difference between the heat source 190 and heat sink 150.

[0013] FIG. 2A discloses a gas burner with thermoelectric power generator according to the present invention. The burner head 220 includes thermoelectric module 240 and heat sink 290. The thermoelectric modules 240 was mounted on top of heat sink 290.

[0014] Thermal insulator 230 insulates the thermoelectric modules 240 from the burner head 220 according to the operating temperature range of thermoelectric modules. Electric insulator 250 provides maximum thermal conductivity and electric insulation between thermoelectric module 240 and the heat sink 290. Heat sink 290 was designed to have fins 295 to increase its heat transfer capability. There are holes or slots 260 on the side of the burner head for the formation of the flame jets. Thermo grease can be used in between the thermal insulators and the thermoelectric modules to improve thermal conductivity.

[0015] Thermoelectric module 240 can be made of conventional Bismuth Telluride based thermoelectric module or nano-composite semiconductors, such as, SiGe/Si composite, with higher thermal conversion efficiency. Heat sink is usually made of aluminum or other material with high thermal conductivity.

[0016] The space underneath the heat sink 290 forms a cooling chamber 300. Fuel/air mixture 280 enters the cooling chamber 300 through the supply connection 270. The cooling chamber 300 connects to a mixture chamber 320 and

the side holes 260 of the burner head. The fuel/air mixture forms flame jets 310 at the side holes 260 during operation.

[0017] An alternate design of the current invention is illustrated in FIG. 2B. There are two layers of thermoelectric modules installed inside the burner head. The thermal conducting plates are designed to have a cooling chamber 300 for forced convection cooling by the fuel/air mixture. When the gas burner is in operation, the flame jet will heat up the burner head 220. The burner 220 will function as heat source for the thermoelectric modules and the heat conducting plates 290 will function as heat sink.

[0018] FIGS. 3A and 3B show alternate layouts of the heat sink. FIG. 3A shows the supply passage 270 is located at the center of the burner and FIG. 3B shows the supply passage located at the end of the burner. In order to increase heat transfer rate of the heat sink, the mixture flow passage was separated by fins 295 and the size of flow passage was properly designed. In FIG. 3A, the fuel/air mixture stream 410 flows in both directions to the mixing chamber 320. In FIG. 3B, the fuel/air mixture stream flows in one direction to the mixing chamber 320.

[0019] The layout of thermoelectric modules 240 is shown in FIG. 4. Thermoelectric modules 240 are connected in series by wires 350, 360 and 370 inside a burner head 220. The outlet wires 360 and 370 connect to a DC/DC converter 380 for proper output voltages. The electricity generated by thermoelectric modules 240 can be used to power electric devices 400, or battery charger 390 etc.

[0020] FIGS. 5A and 5B disclose a round shaped gas burner 500 with thermoelectric power generator according to present invention. A thermoelectric module 240 is installed underneath the burner cap 570. Fuel/air mixture enters the gas burner through supply connection 510 and orifice 520 to mix with air through port 600. The orifice 520 is properly designed according to the fuel thermal content. Heat sink 620 has cooling fins 610 and fuel/air mixture supply passage 630 as shown in FIG. 5B. The heat sink 620 and the burner base 540 form a cooling chamber 300. The fuel/air mixture flow through the cooling chamber cools the heat sink 620. Thermal insulator 230 is placed in between thermoelectric module 240 and burner head 570. Thermal insulator 230 should be properly designed according to the operating temperature range of thermal electric module 240. The burner base 540 was designed to have outward slots 580. Igniter 550 can be used to ignite the fuel/air mixture to form sustainable flame jets 560. The burner cap 570, heated up by flame jet 560, will function as heat source for thermoelectric modules 240. Another side of the thermoelectric module 240 contacts with heat sink 620, which in

turn, is cooled by the fuel/air mixtures in the cooling chamber 300. The thermoelectric module 240 connects to a DC/DC converter 380 through electric outlets 530 and connecting wires 590. Electricity generated by thermoelectric module 240 will power electric devices 390, battery charger 400 etc.

[0021] Although particular systems are disclosed, it will be apparent to persons skilled in the art that modifications may be made without departing from the scope of the invention. All such modifications as well as equivalents are thereof to be included within the scope of the following claims.

What is claimed is:

1. A gas burner with thermoelectric generator comprising: a burner head, at least one thermoelectric power generation module, and a heat sink;

said burner head having at least one fuel supply passage and slots or holes for forming flame jets;

said thermoelectric module and heat sink are installed inside the burner head;

said thermoelectric module incorporated in the burner head in said gas burner for generating electric power.

2. The said thermoelectric module as in claim 1 comprises: a hot side that is in contact with the burner head; and a cold side that is in contact with a heat sink. A thermal insulator can be inserted in between the thermoelectric module and the burner head to control the hot side temperature according to the thermoelectric operating range.

3. The said thermoelectric module as in claim 1 comprises: a plurality of P-type thermoelectric elements, a plurality of N-type thermoelectric elements, said P-type and said N-type thermoelectric elements being positioned in said thermoelectric element spaces.

4. The said thermoelectric module in claim 1 can be designed in different shapes for maximizing power output.

5. The said heat sink in claim 1 can be designed to maximize the heat transfer from the thermoelectric module to the fuel/air mixture.

6. The said heat sink in claim 1 is cooled by the fuel/air mixture.

7. A gas burner according to claim 1 wherein said burner head has electric outlets connected to the said thermoelectric module.

8. The power generated by the said thermoelectric module in claim 1, can be used to power electric devices, such as fans, lights, TVs, battery chargers etc.

* * * * *