

- [54] **EMERGENCY DISTRESS SIGNALING SYSTEM**
- [76] Inventor: **George C. Seaborn, Jr.**, 926 Warfield, Richardson, Tex.
- [22] Filed: **June 21, 1971**
- [21] Appl. No.: **155,098**
- [52] U.S. Cl. **325/64**
- [51] Int. Cl. **H04b 1/00**
- [58] Field of Search.....325/4, 6, 16, 64, 111, 117, 325/118, 361, 166, 187; 343/225, 227; 340/177, 181, 224; 335/205, 54; 179/5 P, 100.1 C

2,610,317	9/1952	Fowler.....	335/54 X
3,579,159	5/1971	Posey	335/205
3,177,298	4/1965	Bodoh	179/100.1 C
3,522,538	8/1970	Czumak	325/166

Primary Examiner—Robert L. Griffin
Assistant Examiner—Barry L. Leibowitz
Attorney—Richards, Harris & Hubbard

[57] **ABSTRACT**

A system for addition to a conventional dispatched vehicle two-way radio communication system to enable an operator to notify a central dispatcher of an emergency condition arising after the operator leaves the vehicle. The system includes a unit which plugs directly into the microphone input of the conventional system and which is responsive to a signal transmitted from a portable transmitter carried by the operator for playing a pre-recorded emergency message through the transmitter of the conventional radio system.

[56] **References Cited**
UNITED STATES PATENTS

3,290,597	12/1966	Denny	325/64
3,316,488	4/1967	Reynolds.....	325/139 X

7 Claims, 9 Drawing Figures

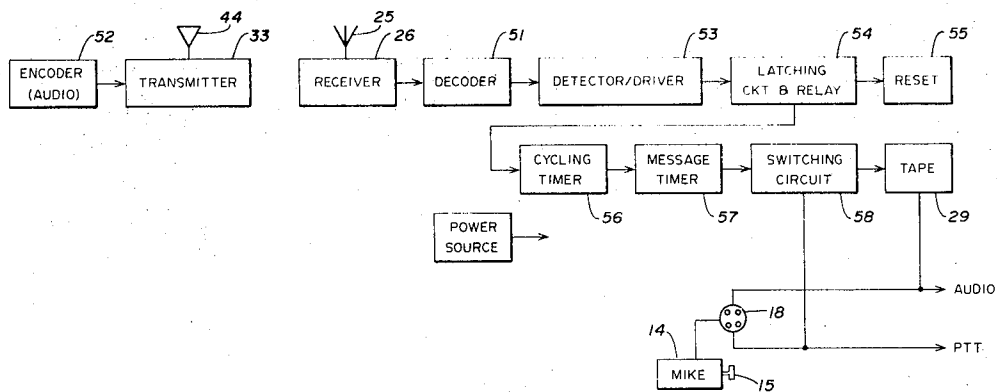

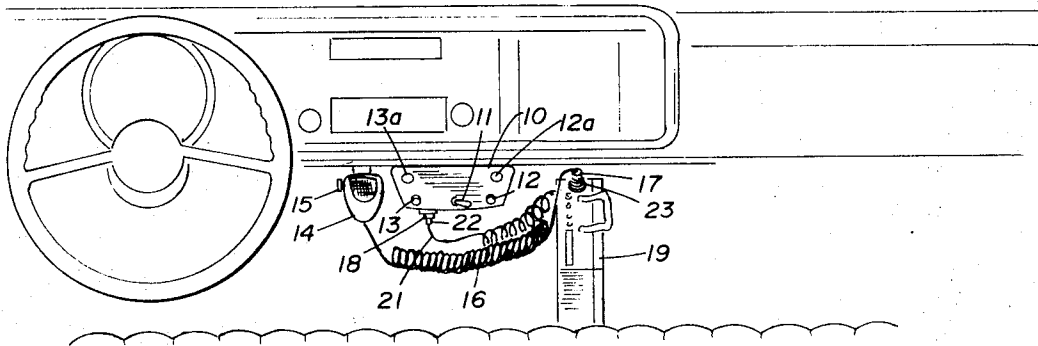

FIG. 1

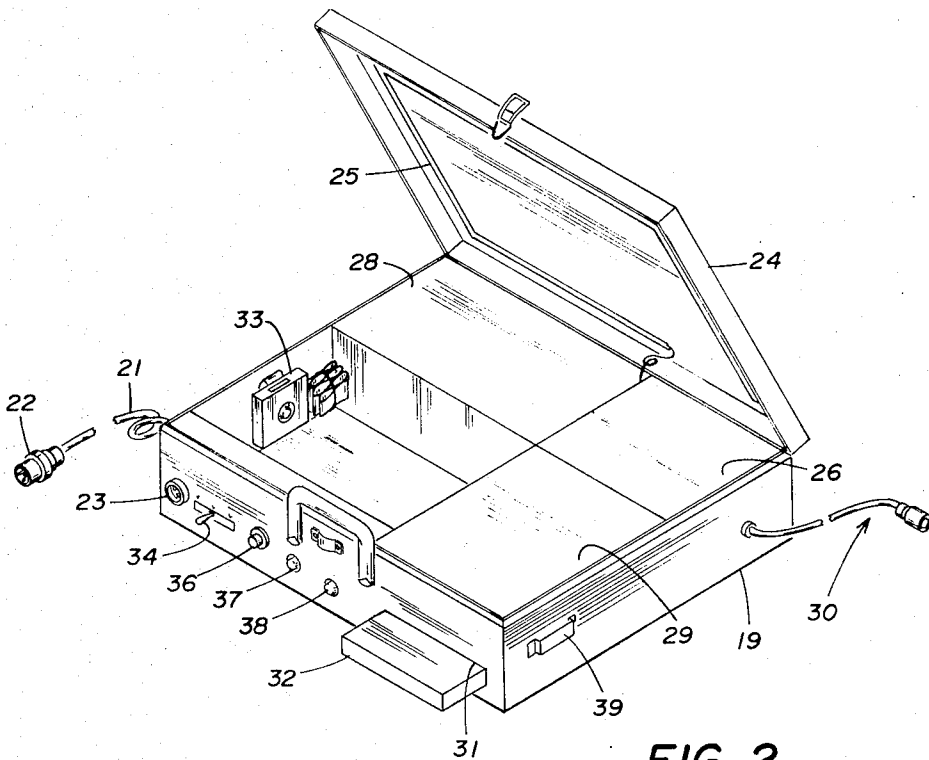

FIG. 2

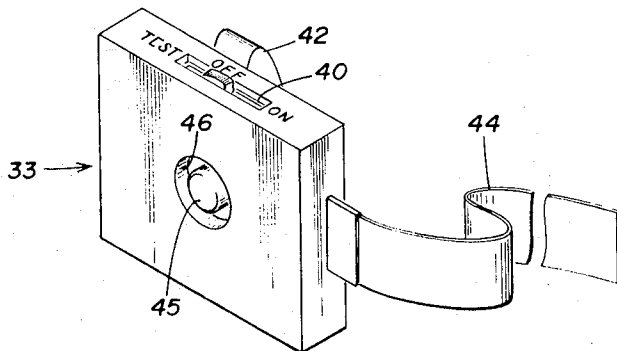

FIG. 3

INVENTOR:
GEORGE C. SEABORN, JR

Richards, Flaminio & Hubbard
ATTORNEYS

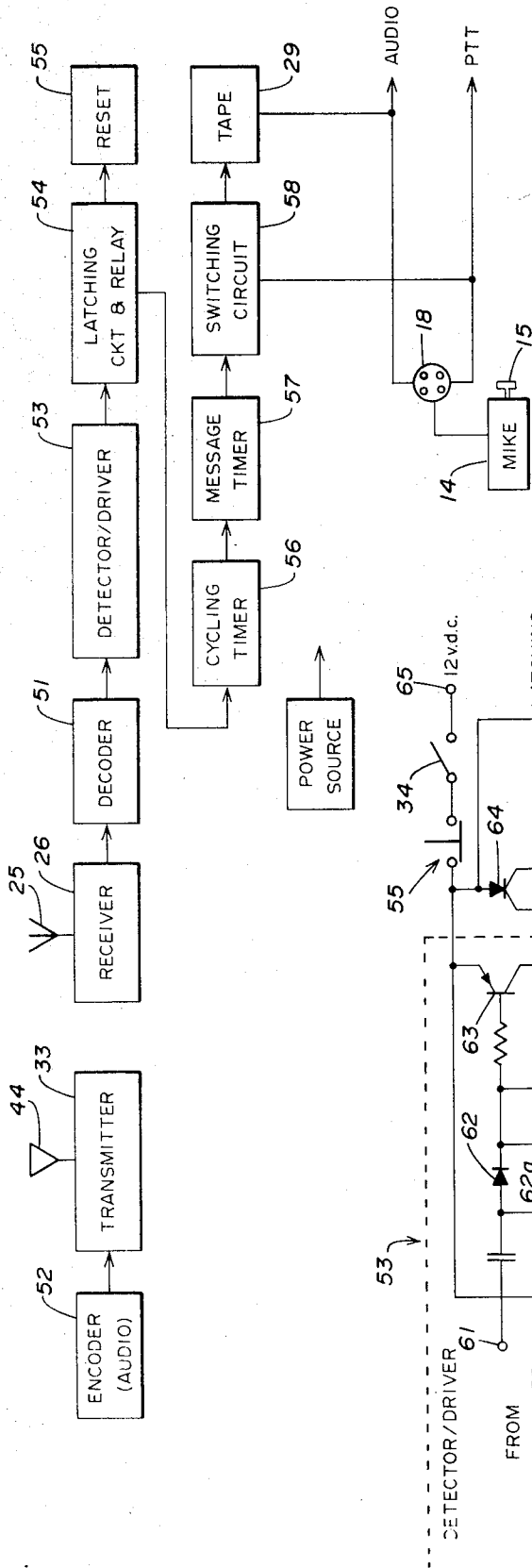

FIG. 4

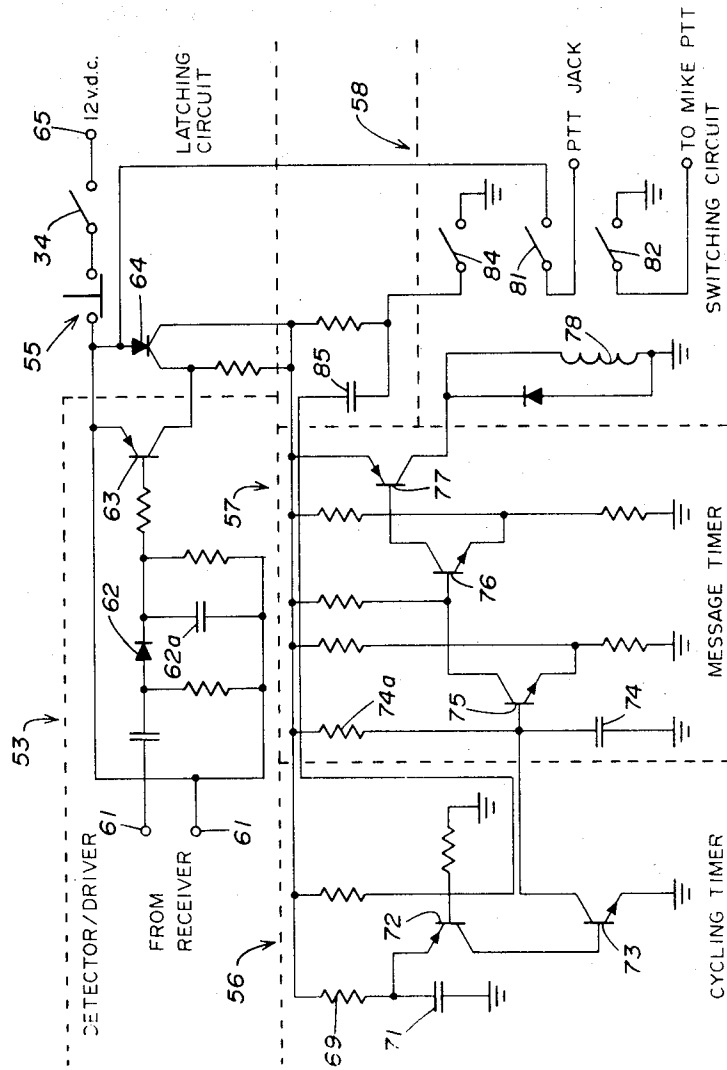

FIG. 5

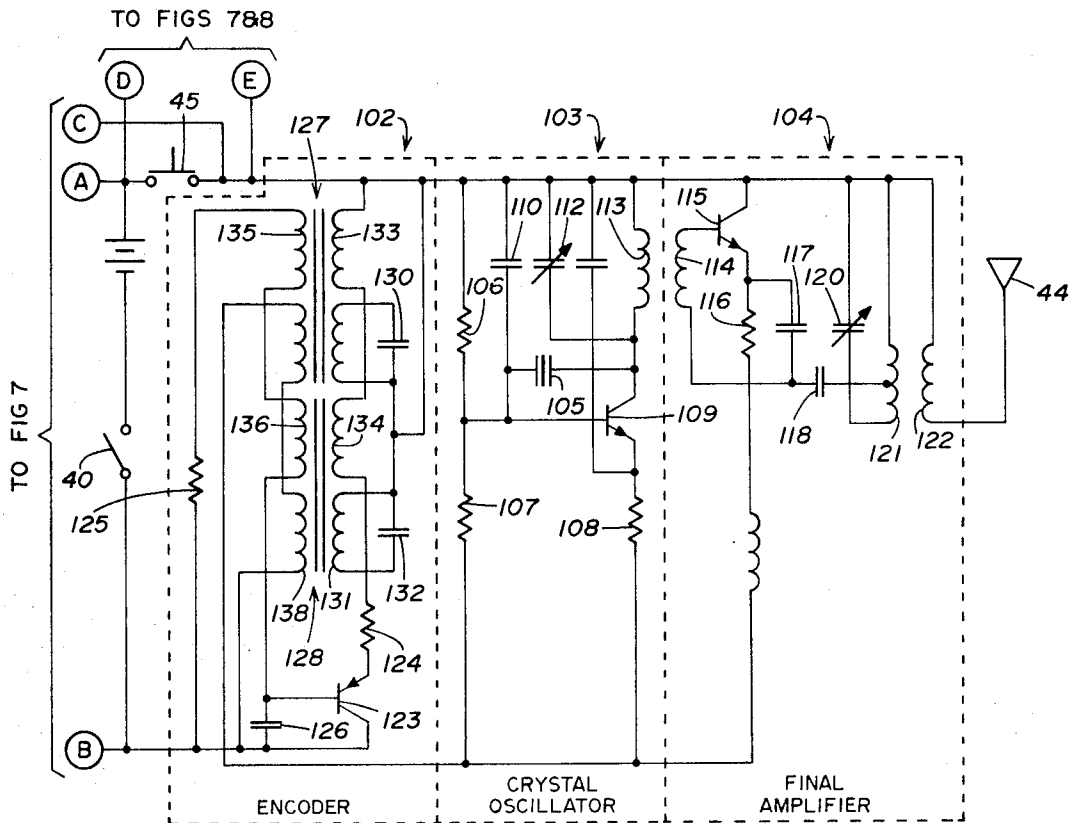

FIG. 6

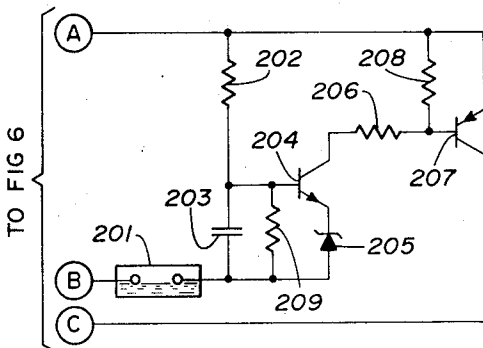

FIG. 7

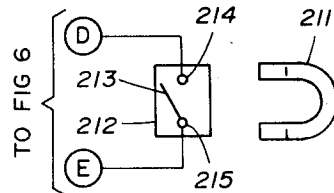

FIG. 8

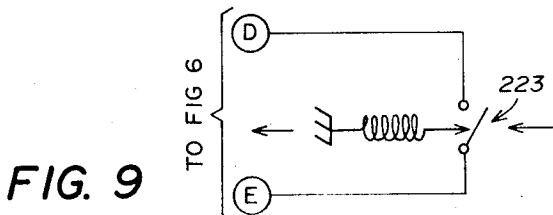

FIG. 9

INVENTOR:
GEORGE C. SEABORN, JR

Richard, Harris & Hubbard
ATTORNEYS

EMERGENCY DISTRESS SIGNALING SYSTEM

BACKGROUND OF THE INVENTION

1. Field of the Invention

The invention relates to a dispatched vehicle radio communications system, and more particularly to an emergency assistance notification system for a conventional communication installation.

2. History of the Prior Art

Two-way dispatched vehicle communication systems have been employed in many different fields. The foremost of these applications have been for police and other public safety and law enforcement organizations although many others such as firemen, private security patrols, etc., use such communication systems extensively. In a two-way police radio system, the generally accepted practice is for a central dispatcher to notify an available patrol car unit of the existence of a need for assistance at a certain location. The patrol car proceeds to that location and then notifies the dispatcher of his arrival there. Once a police officer leaves the vehicle to investigate the need for assistance, his contact with the outside world, and in particular the dispatcher, no longer exists for all practical purposes. That is, if the officer encounters difficulty with handling the situation, for example, if he becomes involved with an armed belligerent, there is no way for him to notify anyone or seek help without returning to the patrol car. If the belligerent has obtained control of the situation and has subdued the police officer, there is absolutely nothing that can be done to summon further aid to the officer's rescue. The present system seeks to lessen the danger of a single police officer investigating an incident and to more fully utilize the existing two-way communication system in a police car to notify the dispatcher of his need for aid.

Previous systems which have sought to expand the effectiveness of an existing dispatched vehicle communication system, such as that shown in U. S. Pat. No. 3,290,597 to G. R. Denny et al., have required extensive modification of the mobile radio equipment. In the Denny et al patent, a police officer carries a portable transmitter unit which sends a distress signal to a special receiver integrated directly into a mobile vehicle radio. Reception of the distress signal activates the conventional mobile transmitter and notifies the dispatcher of the need for aid. Systems of this type require extensive modification of the radio equipment which is carefully regulated by both federal and state agencies, such as the Federal Communications Commission. Extensive testing must be done before such equipment is approved for use. The present add-on system provides a simple plug-in addition to existing equipment, and requires no prior FCC approval before use. Further, the add-on equipment of the present invention can be used with conventional mobile systems and implements emergency signals without requiring replacement of existing radio.

BRIEF SUMMARY OF THE INVENTION

An add-on emergency assistance radio signaling system for use with a conventional dispatched vehicle communication system which includes a vehicle mounted radio receiver and transmitter having a control head including a detachably connected microphone for communication with the central

dispatcher. The emergency system comprises a connector having a first input terminal adapted for connection to the microphone of the conventional system. The connector also has a second input terminal and an output terminal which is connected to the control head microphone input connection of the vehicle mounted transmitter. The connector couples both the first and second input terminals to the output terminal to permit normal usage of the microphone with the vehicle mounted transmitter. The system includes a normally unactuated pre-recorded emergency assistance message player having an output connected to the second input terminal for coupling a message signal into the control head microphone input connection of the vehicle mounted transmitter to transmit the recorded message to the dispatcher. A portable radio transmitter is adapted for carriage by an operator and has a manually operated switch for actuating the transmitter in the event of the operator's need for emergency assistance. A radio receiver detects the signals transmitted by the portable transmitter to operate means for actuating the pre-recorded emergency assistance message player to notify the dispatcher of the operator's need for emergency assistance.

BRIEF DESCRIPTION OF THE DRAWINGS

For a more complete understanding of the present invention and for further objects and advantages thereof, reference may now be had to the following description taken in conjunction with the accompanying drawings in which:

FIG. 1 is a front view of the dashboard of an emergency vehicle showing the control head of a two-way radio incorporating the system of the present invention;

FIG. 2 is a perspective view of a portable embodiment of the present invention, having the cover of the case opened to show the contents;

FIG. 3 is a perspective view of a portable transmitter carried by an operator;

FIG. 4 is a block diagram of the system of the present invention;

FIG. 5 is a schematic diagram of the control equipment of the present invention;

FIG. 6 is a schematic diagram of the portable transmitter of FIG. 4; and

FIGS. 7-9 are schematic diagrams of alternate embodiments of triggering arrangements for the transmitter of FIG. 6.

DETAILED DESCRIPTION

FIG. 1 shows a front view of the dashboard of a police patrol car or other emergency vehicle showing an under-dash mounted control head 10 for a conventional two-way radio system. The control head 10 includes an on-off switch 11 and volume and squelch control knobs 12 and 13, respectively. A pair of lamps 12a and 13a indicate, respectively, operation of the system receiver and transmitter. A conventional system includes a microphone 14 having a push-to-talk switch 15 and a cord 16. The cord 16 is terminated by a multi-contact microphone plug 17 which ordinarily is fitted into a control head microphone input connector 18. In certain radio systems, the microphone cord may be permanently attached to the control head. In such cases, a microphone input connector can be easily added to the control head.

The present system of the invention, as shown in its portable embodiment, includes a carrying case 19 which will be further discussed in connection with FIG. 2 below. The carrying case 19 has extending therefrom a flexible cord 21 terminated by a multi-contact plug connector 22 which is fitted into the control head microphone input connector 18 instead of the microphone plug 17. The mike plug is, instead, connected to an input connector 23 on the outside of the carrying case 19. The system of the invention is now completely added-on to the existing conventional communication equipment and only requires activation of the controls on the outside of the carrying case 19 for operation.

FIG. 2 shows a top perspective view of the carrying case 19 with the cover open to show the equipment therein. Mounted within the lid 24 of the carrying case 19 is a folded antenna 25 for receiving signals from a portable transmitter unit and coupling those signals into a receiver 26 contained within the carrying case 19. The signaling system of the invention could also be used with a removable antenna mounted upon the outside of the vehicle and plugged into the carrying case 19. The case 19 also mounts a pre-recorded message player 29, such as a cassette tape player, having an opening on its front surface 31 for receiving a pre-recorded message cassette 32 which can be changed to vary the message. Also housed within the carrying case 19 is a control circuit 28 which controls activation and timing of the message player 29 and a portable operator-carried transmitter unit 33 stored within the case 19 and which will be described more fully below in connection with FIG. 3.

The controls for the system of the invention are mounted on the outside of the carrying case 19 and include an on-off-test switch 34, the input connection 23 for the microphone of the system, a test switch 36, an on-off indicator lamp 37 and a test lamp 38. The carrying case 19 is also shown equipped with a clip 39 mounted to the outside surface for mounting the portable transmitter unit 33.

Power for the system of the invention can be derived from either a battery mounted within the case 19 or from the battery of the vehicle. In the latter case, a power cord and plug 30 extend from the case 19 and may be inserted into the vehicle cigarette lighter socket or to a special connector leading directly to the vehicle battery.

FIG. 3 shows a perspective view of the portable transmitter unit 33. The transmitter includes conventional crystal controlled A.M. transmitter circuitry with an output power on the order of 100 milliwatts. The output of the transmitter 33 is connected to a tape-type transmitting antenna 44 which can be easily threaded through the loops of an operator's belt or disposed in any manner to extend the antenna to a substantial length. The transmitter 33 may be fixed to the loop of the operator's belt with a clip 42 similar to the type used to clip a measuring tape to a workman's belt. The transmitter unit 33 includes an emergency assistance actuation button 45 which is mounted within a recessed portion 46 on the surface of the housing to prevent accidental triggering of an emergency signal. The transmitter 33 has an on-off-test switch 40 for energizing the unit. The test position transmits a signal to the receiver 26, of FIG. 2, and activates the message player 29 and

the test lamp 38 without connecting a signal to the mobile transmitter of the vehicle radio system. The carrier signal from the transmitter is amplitude modulated by a high stability two-tone oscillator which produces an audio or sub-audio coded output signal.

A block diagram of the system of the present invention is shown in FIG. 4. The portion of the system enclosed within the carrying case 19 of FIG. 1 includes the receiver 26 and the folded antenna 25. The signal transmitted by the antenna 44 of portable transmitter 33 is two-tone modulated by an encoder 52. The signal from the receiver 26 passes through a decoder 51 which operates in response to the same two tones as the encoder 52 produces to prevent inadvertent actuation by a spurious signal. The output of the decoder 51 is fed to a detector/driver 53 which is connected to a latching circuit 54. A reset switch 55 is provided for resetting the system after use. The latching circuit 54 controls a cycling timer 56 which operates a message timer 57 to control a switching circuit 58. The switching circuit 58 performs two functions; first, it energizes the pre-recorded message player 29 and secondly, at the same time applies a signal to the push-to-talk lead of the microphone input connection 18 to activate the mobile radio transmitter. This simultaneous actuation by the switching circuit 58 delivers the pre-recorded emergency message signal into the existing vehicle transmitter.

FIG. 5 is a schematic diagram of the timing and control circuitry of the present invention, and includes the detector driver circuit 53, the latching circuit and reset 54 and 55, the cycling timer 56, the message timer 57 and the switching circuit 58, all of FIG. 4. When a signal from the receiver and decoder is impressed upon input terminal 61, the signal is rectified and filtered by a diode detector 62 and capacitor 62A which applies a signal to the base of a transistor 63. Operation of the transistor 63 supplies current to a latching SCR 64. The SCR 64 latches conductive until it is reset through a normally closed reset switch 55. Conduction of the SCR contact 64 applies current from a source 65 through the on-off switch 34 to a resistor 69 and a capacitor 71 forming an RC timing network in the cycle timer 56. When a sufficient value of voltage is reached on the capacitor 71, a transistor 72 begins to conduct, which in turn energizes the base lead of a transistor 73. Current from the transistor 73 begins to charge a message timing capacitor 74 the voltage across which is applied to the base of a transistor 75. When the voltage on the transistor 75 has reached a prescribed value, current is delivered to the base of a transistor 76 which in turn effects conduction of a transistor 77 to energize the coil of a switching relay 78. Operation of the relay 78 delivers current to the power input of a tape player through contacts 81 and ground to the push-to-talk lead of the control head microphone input connector through contacts 82. Ground is also applied through contacts 84 and a capacitor 85 to the base of the transistor 72 to effect discharge and recycling of the timer 56.

When power is applied to the RC networks 69 and 71, it may take on the order of 45 seconds to charge the capacitor 71 to a sufficient voltage to effect conduction in the transistor 72. This timing cycle is completely variable and may be changed by varying the component

values in the RC network. Passage through one cycle by the timer 56 energizes the message timer 57, the period of which is controlled by the capacitor 74 and resistor 74A and should be the time required to deliver a complete message from the tape, for example 8 seconds. At the end of the tape message, the switching relay 78 is released and not reactuated again until the cycling timer has passed through its 45 second period to reoperate the message timer 57. It should be noted that once the latching SCR 64 has been triggered, the system continues to cycle and periodically deliver messages until someone returns to the equipment and depresses the reset switch 67. Nothing which is done to the portable transmitter unit 33 can affect the periodic delivery of the recorded emergency message to the dispatcher.

FIG. 6 is a schematic diagram of the encoder and transmitter circuitry used in conjunction with the present invention, and includes an encoder 102 and a transmitter stage comprising a crystal oscillator 103 and a final amplifier 104. When the portable transmitter power switch 40 is in the "on" position, closing of the actuation switch 45 applies power to energize the encoder 102, the crystal oscillator 103 and the final amplifier 104 to produce a radio frequency carrier signal as an output from the crystal oscillator 103. The frequency of the RF signal is controlled by a quartz crystal 105. Resistors 106, 107 and 108 supply a bias voltage to a transistor 109 which provides amplification. A pair of capacitors 110 and 111 provide capacitive reactance to sustain the RF oscillations. A tuned LC circuit comprising a variable capacitor 112 and inductor 113 is tuned to the transmitting RF signal. Inductors 113 and 114 serve as an air-wound transformer to provide a drive signal to a final amplifier transistor 115. The transistor 115 is biased by a resistor 116. A pair of capacitors 117 and 118, together with an inductor 119, provide an impedance match between the amplifier transistor 115 and an output tank circuit comprising a variable capacitor 120 and an inductor 121. The inductors 121 and 122 act as an air-wound transformer to couple RF power from the output stage of the transmitter to an antenna 44.

The encoder stage 102 comprises a transistor 123 which is biased by a pair of resistors 124 and 125. Oscillation is sustained due to capacitive reactance from a capacitor 126. A pair of audio or sub-audio modulating frequencies are generated by two tuned transformers 127 and 128. Individual modulating frequencies are determined by an LC tuned circuit, one on each of the transformers 127 and 128. Transformer winding 129 and capacitor 130 provide a tuned circuit for the transformer 127 while transformer winding 121 and capacitor 132 provide a tuned circuit for the transformer 128. Both transformers 127 and 128 are driven by a transistor 123 through a resistor 124 and windings 133 and 134. Oscillation is sustained due to feedback through the transformer windings 135 and 136 and a capacitor 126. Modulation is coupled from the two transformers 127 and 128 to the transmitter through windings 137 and 138. The signal delivered to the input of the transmitter stage comprises two audio or sub-audio tones and is employed to amplitude modulate the RF signal from the transmitter.

The complete system functions as follows after the system has been set up as shown in FIG. 1. Before an operator leaves the vehicle, he may desire to test the system by depressing the test switches 34 and 40 on the carrying case 19 and transmitter 33 to insure proper operation of the system. When the operator leaves the vehicle, he carries along with him the portable transmitter 33. If while the operator is investigating a situation at a distance from the car he encounters difficulty and needs assistance, he depresses the actuation button 45 on the side of the transmitter unit 33 to transmit a two-tone coded, amplitude modulated carrier signal which is received by the antenna 25. The antenna 25 is connected to the receiver 26 which upon receiving the signal passes it through the decoder 51. Two tuned circuits in the decoder discriminate the incoming signal, passing only the two coded signals, if present, through two logic AND gates to energize the detector/driver 53. Receipt of a signal from the transmitter then energizes the latching circuit 54 which starts the cycle timer 56 and the message timer 57 to periodically deliver an emergency assistance message through the control head microphone input connection. The message is transmitted through the conventional radio system of the vehicle to notify the dispatcher of the existence of the need for aid. Because the operator had previously reported his position to the dispatcher when he arrived, there is generally no question of where the aid is needed. The system can be adapted to provide for emergency location of a vehicle which is transmitting a message.

Under certain circumstances, it may be difficult or impossible for an operator carrying the portable transmitter unit 33 to operate the distress signal without calling attention to the fact. Several embodiments of both automatic and secret actuation means have been included to provide means by which the portable transmitter may be actuated covertly.

FIG. 7 is a schematic diagram of a tilt operating mercury switch actuator which may be included within the portable transmitter 33. As shown, a normally unactuated mercury switch 201 is connected to the input of an energizing circuit. When the transmitter is in an upright position, mercury within the switch 201 is near one end of the switch and there is an open circuit between the two internal contacts. When the transmitter is placed in a horizontal position, due perhaps to the person carrying the transmitter having assumed a horizontal position, the mercury switch 201 closes to energize a time delay circuit through the input terminals A and B. A resistor 202 and a capacitor 203 provide an RC time constant so that when the voltage across the capacitor 203 is great enough to overcome the base-emitter voltage of a transistor 204 and the break-down voltage of a Zener diode 205, then base current flows into the transistor 204. Base current places the transistor 204 into a conductive state and current flows through a resistor 206 and the Zener diode 205 to operate a transistor 207. When conducting, transistor 207 completes a circuit path between the input terminal A and the output terminal C which actuates the portable transmitter unit. A resistor 208 serves to reduce leakage current through the transistor 207 while the mercury switch 201 is open in order to prolong portable battery life. A resistor 209 provides a discharge path for capacitor 203 when the

switch 201 is open. The time delay circuit comprising the RC network 202 and 203 prevents accidental actuation due to a temporary closure of the mercury switch which is not intended to operate the transmitter.

FIG. 8 shows a magnetically actuated switch including a reed switch 212 leading to a pair of output terminals. Placing a magnet 211, which may be mounted in the head of a ballpoint pen, near the switch 212 causes a magnetic reed 213 to move toward the magnet thereby closing the terminals 214 and 215. This closure of the switch 212 creates a closed circuit between the output terminals D and E and actuates the transmitter.

FIG. 9 is a schematic drawing of a pressure actuated switch. Such a switch may be used to operate the transmitter in response to movement of a particular part of an operator's body or an object, for example, removal or a revolver from its holster. The switch includes a pair of output terminals D and E. A positive pressure exerted upon the mechanical switch 223 causes the terminals to close and complete the circuit between the output terminals. Completion of the circuit actuates the transmitter to transmit an alarm signal. The embodiment of the FIG. 9 switch is basically a remote push button for the portable transmitter.

It is to be understood that the embodiment shown of the invention above is of the portable variety and the system could be easily adapted to a permanent installation within a vehicle by mounting the equipment within the case 19 at a convenient location under the dash of the vehicle.

Having described the invention in connection with certain specific embodiments thereof, it is to be understood that further modifications may now suggest themselves to those skilled in the art and it is intended to cover such modifications as fall within the scope of the appended claims.

What is claimed is:

1. A portable add-on emergency assistance radio signaling system for interconnection into a conventional dispatched vehicle communication system already present in a vehicle, said conventional dispatched vehicle communication system including a vehicle-mounted radio receiver and transmitter having a control head including a detachably connected microphone for communication with a central dispatcher, wherein said portable add-on emergency assistance radio signaling system comprises:

a portable add-on unit for being removably electrically plugged in between said microphone and said control head to enable normal conventional usage of said microphone with said vehicle-mounted transmitter;

said add-on unit further including a normally unactuated pre-recorded emergency assistance message player having an output connected to the input of said control head;

a portable radio transmitter adapted for carriage by an operator and having a switch operable to actuate said portable radio transmitter in the event of the operator's need for emergency assistance, said portable radio transmitter generating a signal which is modulated by coded frequency tones;

a radio receiver mounted within said add-on unit receptive to signals transmitted by said portable transmitter and including means for decoding said

coded frequency tones; and means within said add-on unit responsive to reception of a signal from said portable transmitter by said receiver mounted in said portable add-on unit for both actuating said pre-recorded emergency assistance message player and for coupling a message signal into said control head to notify the dispatcher of the operator's need for emergency assistance.

2. An add-on emergency assistance radio signaling system as set forth in claim 1 wherein said message player actuating means includes:

a timing circuit actuated in response to reception of a transmitted signal by said receiver for energizing said player for a preselected period of time and then deactuating said player.

3. An add-on emergency assistance radio signaling system as set forth in claim 1, wherein said message player actuating means includes:

a cycle timing circuit actuated in response to reception of a transmitted signal by said receiver, said circuit cyclically remaining actuated for a first preselected period of time and then deactuated for a second preselected period of time; and

a message timing circuit triggered in response to actuation of said cycle timing circuit and remaining actuated for a third preselected period of time of energizing said message player during the third preselected period and then cyclically repeating each time said cycle time is actuated.

4. An emergency assistance radio signaling system as set forth in claim 1 wherein said message player actuating means includes a relay having a normally open contact set, one of said contacts being connected to a power source and the other being connected to the power input of said player, said relay being operated in response to reception of a signal from said portable transmitter by said receiver.

5. An emergency assistance radio signaling system as set forth in claim 1 wherein said portable radio transmitter comprises:

a radio frequency transmitter including a crystal controlled oscillator for generating a carrier signal for said transmitter;

an encoder for producing a plurality of preselected tones for amplitude modulating the carrier from said transmitter; and wherein said signal responsive means includes

a decoder and gating means responsive to a transmitter carrier signal modulated by said plurality of preselected tones.

6. An emergency assistance radio signaling system as set forth in claim 1 wherein said portable transmitter also includes:

means for actuating said transmitter upon disorientation of the transmitter body from a predetermined position for a preselected period of time.

7. An emergency assistance radio signaling system as set forth in claim 1 wherein said portable transmitter also includes:

an actuation switch formed of magnetic material; and

a movable magnet, said actuation switch being closed in response to proximity of said magnet to said switch.

* * * * *