

A. B. Weaver,

Truss.

No 25,597.

Patented Sep. 27, 1859.

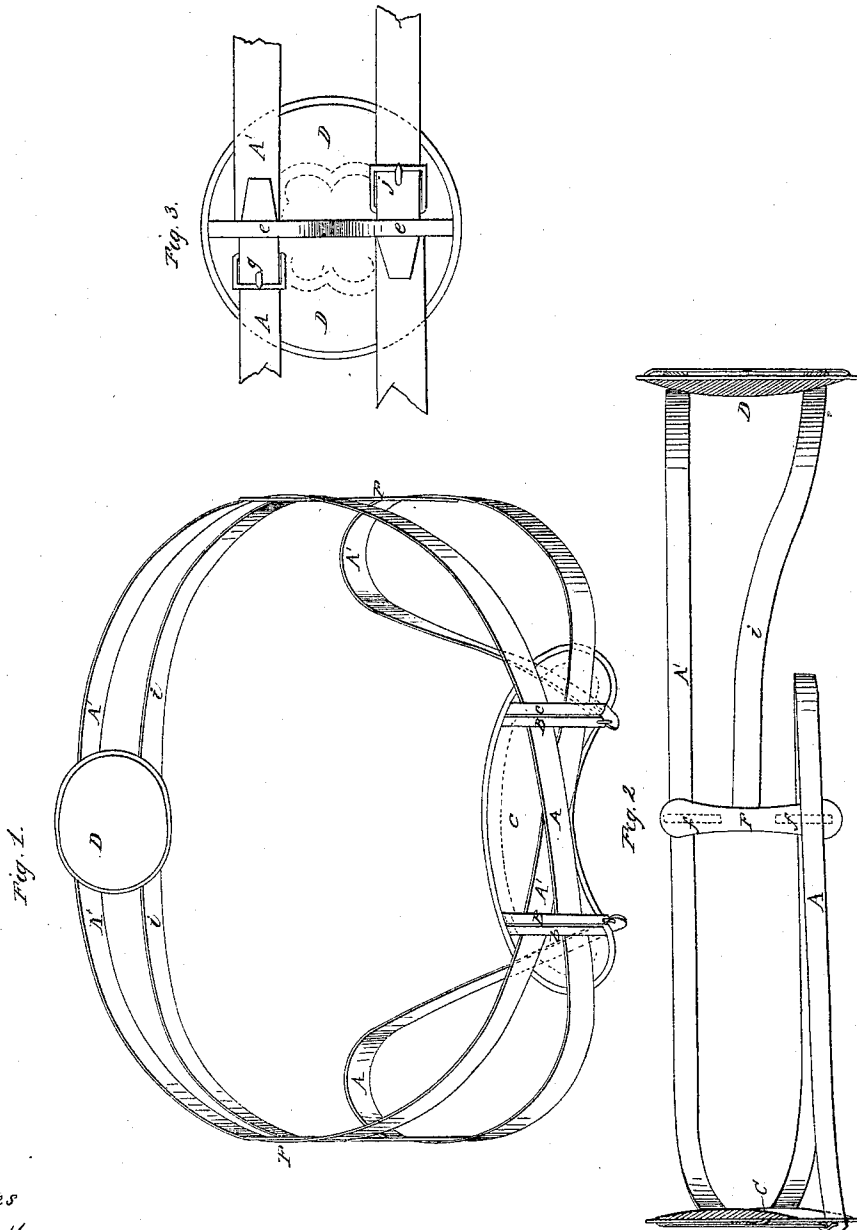

Witnesses
John W. Hoyle
W. B. Johnson

Inventor
A. B. Weaver

UNITED STATES PATENT OFFICE.

A. B. WEAVER, OF CARTHAGE, INDIANA.

ABDOMINAL SUPPORTER.

Specification of Letters Patent No. 25,597, dated September 27, 1859.

To all whom it may concern:

Be it known that I, A. B. WEAVER, of Carthage, in the county of Rush and State of Indiana, have invented a new and useful
5 Improvement in Abdominal Supporters; and I do hereby declare that the following is a full description thereof, reference being had to the accompanying drawings, and the letters of reference marked thereon, making
10 part of this specification.

My invention relates to certain improvements in abdominal supporters, described specified and represented as follows:

Figure 1 is a bird's eye view of the strap
15 with all its parts arranged in position for use. Fig. 2, is a sectional view through the front and back pads. Fig. 3 shows the back pad, and the arrangement of straps and, buckles, upon its outer side (A). Fig. 1, is a
20 long strap, which is connected with the short strap (B) by means of buckles so that the strap (A) may be shortened or lengthened, to suit the convenience of the wearer. This strap passes across the front pad (C) at or
25 near its lower edge, around the leg of the wearer, returns and passes through loops (a, b), from thence it passes around the hips to the back pad (D) where it is sustained by loop (e). This strap (A) is sustained in
30 proper position at the hips by means of loops (f) and pad (F), a similar strap (A'), attached to, and starting from the front pad (C), in the same manner as strap (A), in an opposite direction to strap (A) and cross-
35 ing it in front of the front pad (C) as represented, in Fig. 1. It passes around the hips

across the hip pad (F) in a manner similar to strap (A) to the back pad (D) and connecting with the strap (A) in front of the back pad (D) by means of buckle (g). 40

The arrangement herein described insures the wearer against any displacement of the pads (i i) on straps attached to the hip pads (F) (F), and buckled together in front of the back pad (D), by means of which the
45 hip pads (F, F,) are secured in their proper positions. The pads (C, D, F) are composed of cloth and leather, and contain no mineral substance; so that they cannot corrode by heat and moisture from the body, they are
50 flexible, and comfortable to the wearer; by crossing the straps (A, A') as represented in front of the front pad (C) the pressure will always be equal against the bowels, while the hip pads (F F) serve to keep the
55 straps separated and prevent an unequal strain upon any part of the front pad; and by means of the buckles, (g) (j) these straps or belts may be adjusted, to fit, the form or size of any person. 60

What I claim as my invention and desire to secure by Letters Patent is—

The employment of the hip pads (F F) and center hip straps (i i) in combination with the straps (A, A'), arranged substan-
65 tially as described for the purposes set forth.

In testimony of which invention I have hereunto set my hand.

A. B. WEAVER.

Witnesses:

JOHN H. FRAZEE,
WILLIAM JOHNSON.