

[54] **FOOD CONTAINER**
 [75] Inventor: **Peter C. Carveth**, Chicago, Ill.
 [73] Assignee: **The Quaker Oats Company**,
 Chicago, Ill.
 [22] Filed: **June 4, 1973**
 [21] Appl. No.: **366,985**

3,486,615 12/1969 **Woskin**..... 206/491
 3,487,915 1/1970 **Scott**..... 206/491

Primary Examiner—William I. Price
Assistant Examiner—Ro E. Hart
Attorney, Agent, or Firm—Donnie Rudd

[52] U.S. Cl..... **206/491**, 229/40, 206/45.31,
 206/45.34
 [51] Int. Cl..... **B65d 73/00**
 [58] Field of Search 206/491, 492, 45.31, 45.34;
 229/3.5, 87, 40

[57] **ABSTRACT**

A container for packaging cookies or other food products is disclosed having a bowl with an upper lip and a wrap-around support attached to the upper lip and encircling the bowl to provide protection thereof. The wrap-around support may have a tear strip therein to provide access to the product. In another embodiment a series of bowls are placed on the wrap-around container and it is folded around to force them against each other for support. Weakened lines between the bowls provide for separation and access to the product.

[56] **References Cited**

UNITED STATES PATENTS

3,281,051 10/1966 **O'Brien**..... 206/491
 3,339,724 9/1967 **Hickin** 206/491
 3,349,985 10/1967 **Salway** 206/491

1 Claim, 8 Drawing Figures

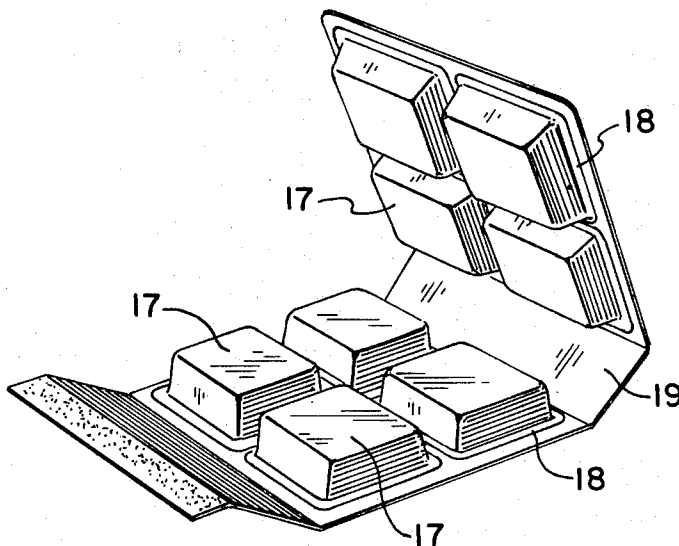

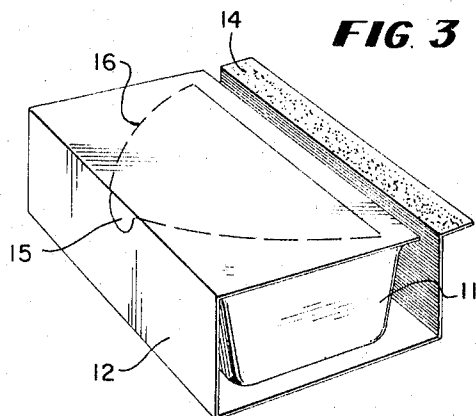
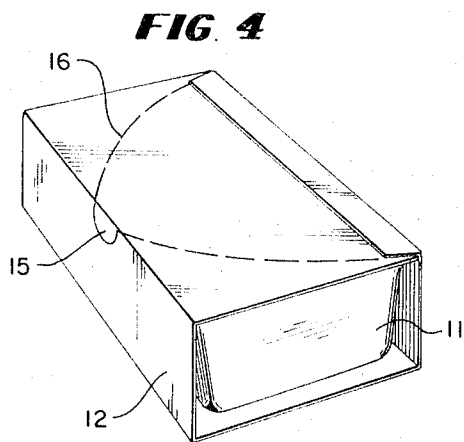
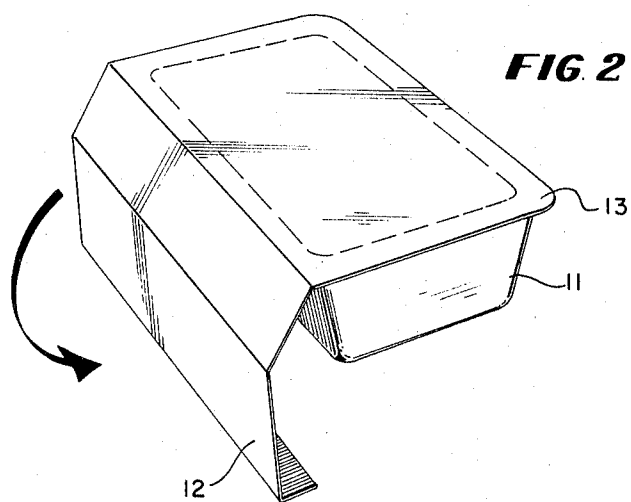
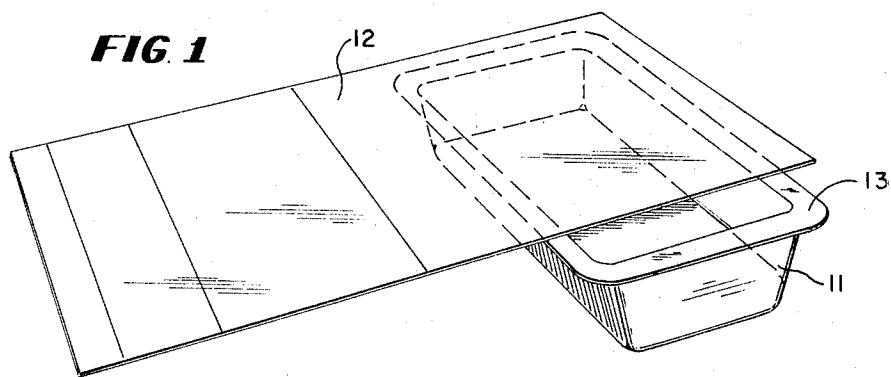

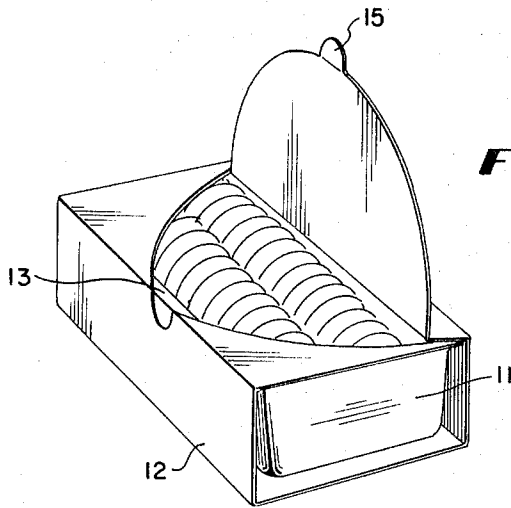

FIG. 5

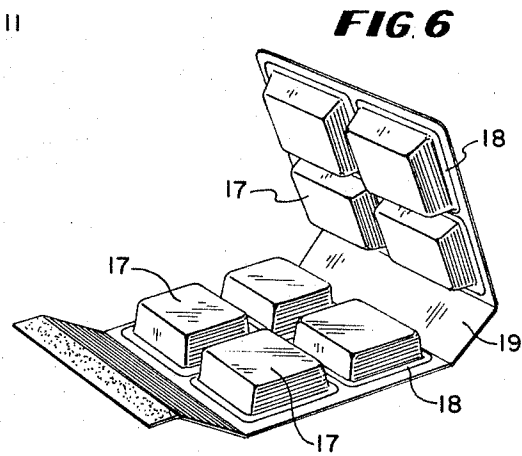

FIG. 6

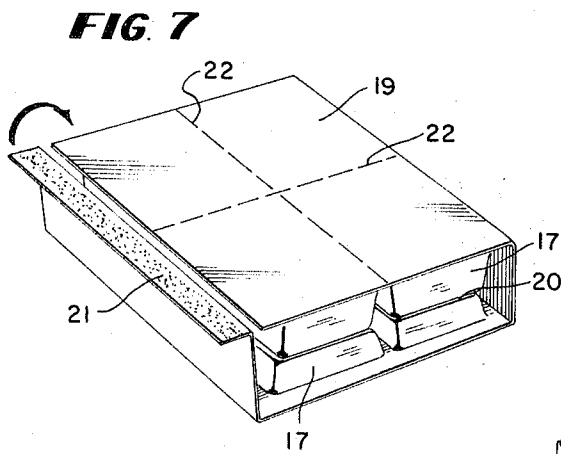

FIG. 7

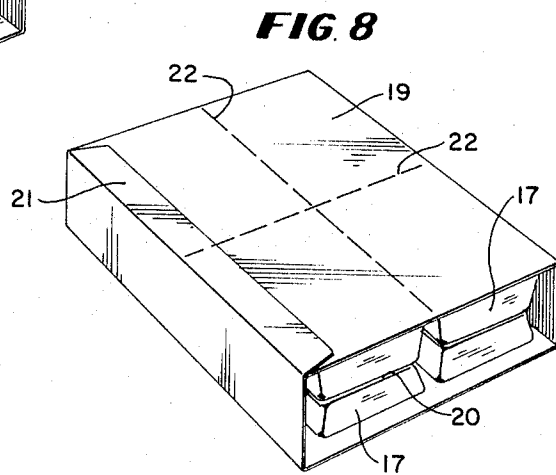

FIG. 8

1

FOOD CONTAINER

BACKGROUND OF THE INVENTION

1. Field of the Invention

This invention relates to a package for food products.

2. Description of the Prior Art

There are many types of packages for food products. With newly developed molding techniques it is possible to make bowls or containers for food products which are semi-rigid in nature. If a semi-rigid bowl is provided, there must be some method of providing support for the bowl, especially if it is to contain a crushable material such as a cookie and if the bowls must be stacked one on the other. The support mechanism must also have means for providing access to the product. The present invention provides for this need.

SUMMARY OF THE INVENTION

It is an object of this invention to provide a package for food products which has an inner semi-rigid bowl with adequate support thereof and with access provided for the product.

The object of this invention is accomplished by a container for packaging cookies or other food products, said container comprising a semi-rigid bowl with a flattened upper lip and a wrap-around support one side of which is sealed to the flattened upper lip of the container to form a hermetically sealed container and the remaining portion of the wrap-around support being wrapped about the container and sealed to itself to form a protective support for the container, the wrap-around support having a weakened line therein forming a tear strip which has a small portion overlapping the flattened upper lip of the container but which when torn provides access to a substantial portion of the bowl.

In another embodiment the object of this invention is accomplished by a container for packaging food products or the like, said container comprising a rigid wrap-around support with a plurality of semi-rigid bowls hermetically sealed thereto with the wrap-around support enclosing the bowls to force the bottom of one to press upon the bottom of another for support thereof, the wrap-around support being sealed upon itself to provide a protective support around the bowls, and the wrap-around support having weakened lines between the bowls to provide separation of the bowls into individual units with access thereto.

In its simplest form, this invention has a bowl or semi-rigid molded container with a flat upper lip. A support, usually of a heavy material, has one side firmly attached to the upper lip of the container to seal it. The wrap-around support is then wrapped around the bowl to provide a hard carton effect and thus protect the bowl. Access to the product can either be by tearing a corner of the upper lip or by pulling a weakened line tear strip on the wrap-around carton. If a weakened line tear strip is provided, it would have a minimum contact with the sealed upper lip since they both obviously will provide the greatest difficulty in removing the tear strip.

In another embodiment, a plurality of semi-rigid bowls are attached to opposing sides of the wrap-around support and the wrap-around support is then folded over to have the bowls contact one another and

2

thus provide support for the entire system. Weakened lines between the bowls provide for separation of the bowls. Access to the product can then be by either tearing a corner and peeling it away or else a weakened line tear strip such as is discussed above.

BRIEF DESCRIPTION OF THE DRAWING

This invention may be more fully described but is not limited by the accompanying drawings in which:

FIG. 1 is a perspective view of my invention showing the placement of the wrap-around support on the bowl;

FIG. 2 is a perspective showing how the support is sealed and wrapped around the bowl;

FIG. 3 is a perspective view of the wrap-around support before it is finally attached to itself;

FIG. 4 is a perspective view of the wrap-around support and container in its finished position;

FIG. 5 is a perspective showing the opened wrap-around support;

FIG. 6 is a perspective view showing a plurality of semi-rigid bowls in place on a wrap-around support;

FIG. 7 is a perspective view showing the folded plurality of bowls just before the sealing of the wrap-around support; and

FIG. 8 is a perspective view of my invention showing the finished wrap-around support holding a plurality of semi-rigid bowls.

In the drawings I have used the numeral 11 to refer to a semi-rigid bowl. The wrap-around support 12 is sealed at the upper lip 13 of the semi-rigid bowl. The wrap-around support is then wrapped about the bowl and sealed by overlap 14 being attached to the wrap-around support to form a complete encircling of the bowl. Access to the product can be had by pulling tab 15 to effect tearing along weakened line 16 and thus expose the product.

In another embodiment, a plurality of semi-rigid bowls 17 are attached at their upper lips 18 to wrap-around support 19. The wrap-around support is then wrapped about the bowls to force them one against the other at their bottoms 20 and the wrap-around support is attached to itself by tab 21 being attached to the remainder of the wrap-around support. Weakened lines 22 provide for separation of the individual bowls and provide corners which may be peeled away to provide access to the product.

DESCRIPTION OF THE PREFERRED EMBODIMENTS

The attached drawings and above description constitute the preferred embodiments of this invention.

Having fully described this new and unique invention, I claim:

1. A container for packaging food products or the like, said container comprising a rigid wrap-around support with a plurality of semi-rigid bowls hermetically sealed thereto with the wrap-around support enclosing the bowls to force the bottom of one to press upon the bottom of another for support thereof, the wrap-around support being sealed upon itself to provide a protective support around the bowls, and the wrap-around support having weakened lines between the bowls to provide separation of the bowls into individual units with access thereto.

* * * * *