

March 5, 1963

A. K. SCHOTT

3,079,824

PUNCHING DEVICE HAVING A SPRING BIASED STRIPPER

Filed Aug. 9, 1960

Fig-2

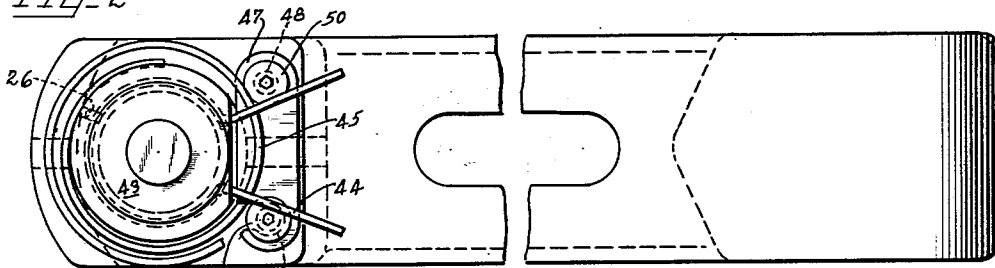

Fig-1

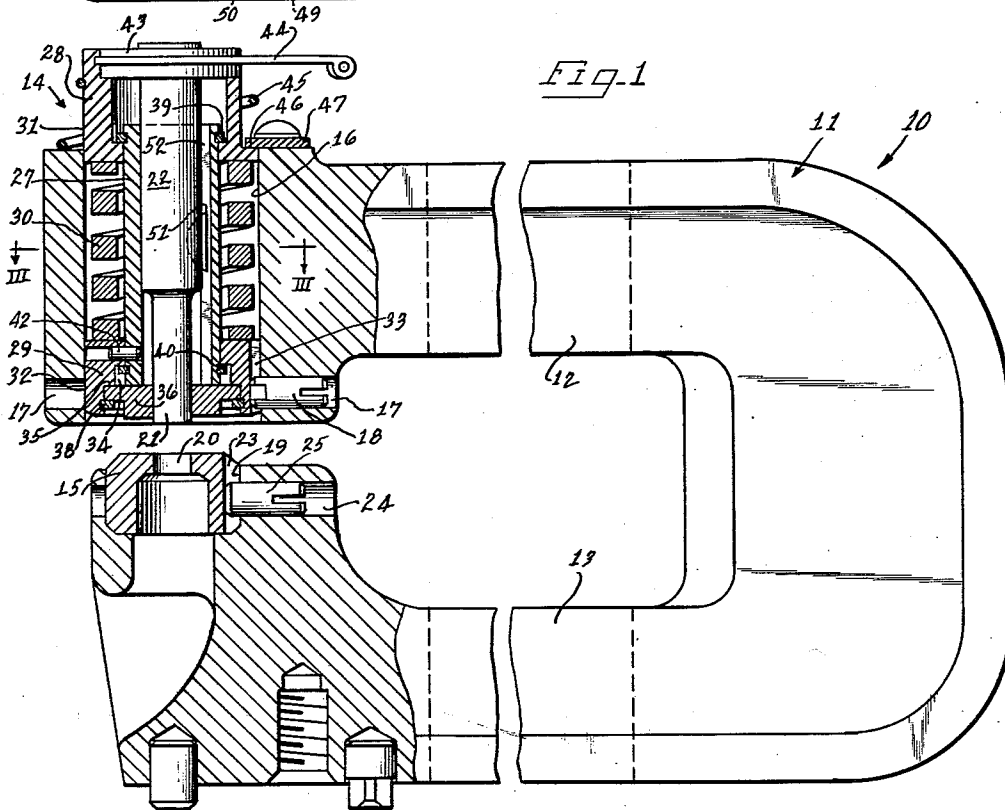

Fig-3

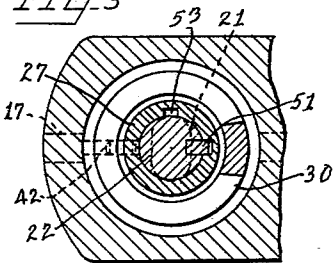

Fig-4

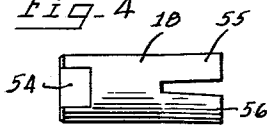
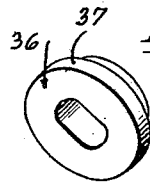

Fig-5



Inventor
Arthur K. Schott

Wells, Sherman, Meeni, Shaw & Singer Attys.

1

2

3,079,824

PUNCHING DEVICE HAVING A SPRING BIASED STRIPPER

Arthur K. Schott, Kenmore, N.Y., assignor to Houdaille Industries, Inc., Buffalo, N.Y., a corporation of Michigan

Filed Aug. 9, 1960, Ser. No. 48,376
6 Claims. (Cl. 83—140)

This invention relates generally to punching devices of the unitized type, and more specifically to improved punch guidance and retention means incorporated therein.

Although the principles of the present invention may be included in various punching devices, a particularly useful application is made in punching devices of the unitized or subpress type in which a die is carried in alignment with a punch and guide assembly by a C-shaped frame or holder. Punching devices of this general type are known in the art, and have been provided with punches and dies whose cutting edges are both circular and shaped (non-circular). Devices of this type have also been provided which include a guide button which has a close sliding fit with the working end of the punch.

It is apparent that it is more expensive to provide and operate devices of this type where the punch tip is provided with guidance means than when such means are omitted, and yet when the highest quality of punching is required, it has been found necessary to employ punch tip or working end stripping means. In the past, this has necessitated the use of two separate devices, one which incorporates the guided tip means, and the other which, for economy reasons, omits the same.

It is also known in the art that shaped punches and dies require indexing or keying to maintain them accurately in alignment so as to preclude any possible relative angular movement.

The greatest manufacturing economies can be obtained when a single holder may be used for a variety of sizes and shapes of punches and dies, and to this end, it is preferable that the punch and guide assembly thereof be removable for replacement purposes. Such assembly typically is slidable in the upper arm of the holder and is maintained in a raised or elevated position by appropriate lifting means. Means have previously been provided for holding such assembly in the holder in a manner that such assembly can reciprocate, but yet not inadvertently escape, for example during handling thereof.

Accordingly, it is an object of the present invention to provide a punching device of the type described which is provided with improved means for guiding and angularly locating the punch and guide assembly thereof.

A further object of the present invention is to provide a punching device of the type described in which there is embodied improved means for retaining the punch and guide assembly thereof.

Yet another object of the present invention is to provide punch and guide assembly retaining and guiding means which permits use of either a round punch or a shaped punch alternatively in the same assembly.

A still further object of the present invention is to provide a punch and guide assembly for a punching device of the type described in which a stripper button may be selectively included or omitted in accordance with work requirements.

Many other advantages, features and additional objects of the present invention will become manifest to those versed in the art upon making reference to the detailed description and the accompanying sheet of drawings in which a preferred structural embodiment incorporating the principles of the present invention is shown by way of illustrative example.

On the drawings:

FIGURE 1 is a side elevation view, partly in cross-section, of a punching device equipped with improved punch guidance and retention means provided in accordance with the principles of the present invention;

FIGURE 2 is a top view of the punching device shown in FIGURE 1;

FIGURE 3 is a fragmentary cross-sectional view taken along line III—III of FIGURE 1;

FIGURE 4 is an enlarged elevational view of a novel locating pin provided in accordance with the principles of the present invention; and

FIGURE 5 is a perspective view of a novel and stripping guide button employed in the device shown in FIGURE 1.

As shown on the drawings:

The principles of this invention are particularly useful when embodied in a punching device assembly such as illustrated in FIGURE 1, generally indicated by the numeral 10.

The punching device 10 includes a C-shaped frame or holder 11 having an upper arm 12 and a lower arm 13 in which there are respectively supported a punch and guide assembly 14 and an apertured die 15.

The upper arm 12 has a bore 16 in which the punch and guide assembly 14 is reciprocably supported and guided. To this end, the upper arm 12 is provided with a circular opening 17 which intersects the bore 16 and preferably passes through the holder on both sides thereof as shown so that it is open at both ends to removably receive a locating pin 18 which also is of circular cross-section and which is rotatably disposed in the opening 17 as shown.

The lower arm 13 has a bore 19 in which the die 15 is received, the die 15 having an aperture 20 aligned with the working end 21 of a punch 22. The die 15, especially if the opening 20 is shaped, is provided with a slot 23 which is registerable with a second circular opening 24 disposed in the lower arm 13, and intersecting the bore 19 in the manner that the opening 17 intersects the bore 16 of the upper arm 12. Within the opening 24 there is provided a locating pin 25, the inner end of which is received within the slot 23 for fixing the angular position of the die 15. As shown in FIGURE 3, the working end 21 of the punch 22, and also the aperture 20 in the die 15, are of shaped or oval configuration, the oval configuration being used here to be representative of all non-circular shapes of working tips of punches and die apertures. To retain the die 15 in position, a setscrew 26 shown in FIGURE 2 is threadably received through an end or forward face on the lower arm 13.

The punch and guide assembly includes an elongated sleeve 27, an annular upper collar 28 slidably disposed at the upper end of the sleeve 27, a lower annular collar 29 disposed about the lower end of the sleeve 27, and a stripping spring 30 extending about the sleeve 27 and acting between the upper collar 28 and the lower collar 29 to bias such collars apart. The upper collar 28 has an outer surface 31, and the lower collar 29 has an outer surface 32 which are in direct slidable engagement with the upper arm 12 within the bore 16 thereof. The lower collar 29 has a slot 33 in its outer surface 32 which is defined by a pair of confronting walls which extend parallel to the direction in which the punch and guide assembly 14 is reciprocable. The slot 33 registers with the opening 17 so that the inner end of the locator pin 18 is closely and slidably received within the slot 33. The lower collar 29 is further provided with a pair of concentric recesses 34, 35 which open downwardly, the recess 35 being internally slotted to receive a snap ring. Thus the lower collar 29 is provided with the recess 35 for removably receiving and retaining a guide and/or stripper button 36 shown in de-

tail in FIGURE 5. The guide button 36 has a major peripheral portion 37 which corresponds to the configuration of the recess 35 and is received therein, and axially terminates adjacent to the slot therein so that it is held in place therein by a removable snap ring 38. The opening in the guide button 36 has a configuration corresponding to the working end of the punch 21, and has a close sliding fit therewith to enable accurate stripping of the workpiece from the working end 21 and for guiding the same.

The sleeve 27 is grooved at its ends and receives an additional pair of snap rings 39, 40 axially outwardly of shoulders of the collars 28, 29 respectively for limiting the distance apart which the spring 30 can urge such collars, the stripping spring 30 thereby being held in partial compression.

A locking pin 42 coacts between the lower collar 29 and the sleeve 27 to preclude axial or angular relative movement therebetween. Thus the lower end of the stripping spring 30, the lower collar 29, and the sleeve 27 are thus slidable as a unit and are guided by the locating pin 18 for such movement with respect to the holder 11.

The punch and guide assembly 14 further includes the punch 22 which has a head 43 which projects from the upper collar 28, the body of the punch 22 being directly slidable within the sleeve 27. The head 43 of the punch 22 has a peripheral slot which registers with an internal slot in the upper collar 28, there being a manually removable snap ring 44 received therein. The side of the collar 28 is cut away for a few degrees so that the free ends of the spring can project horizontally therefrom for manual grasping thereof as shown. When the snap ring 44 is compressed, the punch 22 and snap ring 44 may be removed as a unit since the ring 44 is received to the extent necessary within the head 43. A lifting spring 45 cooperates with the upper surface of the upper arm 12 and a groove in the outer surface 31 of the upper collar 28 to provide an upward biasing or lifting force to the punch and guide assembly 14.

The punch and guide assembly 14 is provided with an upwardly directed shoulder 46 carried on the upper collar 28, which shoulder 46 is directed in the direction of the bias from the spring 45. To cooperate therewith in retaining the punch and guide assembly 14 and in holding the lifting spring 45 in partial compression, there is provided an elongated stop plate 47 which is disposed and supported on the upper surface of the upper arm 12 of the holder 11. The stop plate 47 overhangs a portion of the bore 16 so that its lower surface is engaged by the shoulder 46 to limit upward movement of the punch and guide assembly 14. As best seen in FIGURE 2, the stop plate 47 has at one end an aperture 48 and at the other end a laterally directed slot 49, a pair of screws 50, 50 respectively extending through the aperture 48 and the slot 49 to hold the elongated stop plate securely in position. When the screws 50 are loosened, the plate 47 may be pivoted about the aperture 48 for removal of the punch and guide assembly 14 as a unit.

The body of the punch 42 is provided with a recess which receives a Woodruff key 51 which projects therefrom into an elongated slot 52 in the sleeve 27. The sleeve 27 is provided with an additional slot 53 best seen in FIGURE 3, as is also the die 15, so that the shaped punch 22 may be selectively positioned in either of two angular positions.

Referring again to FIGURE 4, it will be noted that the pin 18 has a pair of flat portions 54, which are the portions thereof which snugly slidably fit within the slot 33 of the lower collar 29. At the other end of the pin 18, and in the corresponding end of the locating pin 25, there is provided a pair of spaced integral axially directed bifurcations 55, 56 at least one of which is resilient and which have a free position slightly greater than the size of the opening 17. For example, I have found that if the

dimension across the bifurcations is about .005 inch greater than the diameter of the opening 17, the locating pin 18 will be held snugly therein during the vibratory or shock type usage of the device 10. The bifurcations 55, 56 are preferably slightly spaced apart so as to be able to receive a rotating tool therein for aligning the flats 54 with the slot 33.

It will be noted that the disclosed punching device has a combination of features of structure by which the same components can be used in a considerable number of applications. As illustrated, the device receives and accurately guides a shaped punch and die, and the punch 22, guide or stripper button 36, and die 15 may be rotated to an angularly spaced position where similar guidance is provided. Further, where another size or configuration is desired, these same components may be easily removed and replaced. Even though such be done, all other components can continue to be used. Further, if less exacting work is required, the guide button 36 may be removed readily by the use of the device. It is also apparent that the punch, die, and guide button components may be employed which are adapted to make circular openings. Furthermore, the locating pins 18, 25 may be retracted by means entering the opposite end of the openings 17 and 24 respectively so that the holder will receive a punch and guide assembly which is not provided with a slot 33 and a die which is not provided with a slot 23. Thus the instant combination of punch guidance and retention means is especially versatile, so that one assembly may be used in a number of applications.

Although various minor modifications might be suggested by those versed in the art, it should be understood that I wish to embody within the scope of the patent warranted hereon all such embodiments as reasonably and properly come within the scope of my contribution to the art.

I claim as my invention:

1. A punching device comprising in combination: a C-shaped frame having upper and lower arms with axially aligned bores therein; an apertured die removably secured in the bore of the lower of said arms; a punch and guide assembly reciprocally disposed in the bore of the upper of said arms, said assembly including an elongated punch-guide sleeve, an upper annular collar slidably surrounding the upper end of said sleeve and a lower annular collar surrounding the lower end of said sleeve, a stripping spring means extending about said sleeve and biasing said collars apart, a pair of snap rings each carried by one end of said sleeve and acting against said collars to hold said stripping spring means in partial compression, said collars each having a surface in direct slidable engagement with said upper arm, a punch slidably received within said sleeve and projecting from said upper collar, a manually removable snap ring securing said head end to said upper collar, said punch having a working end adapted to cooperate with said die, and said lower collar having a downwardly directed internal recess defining a downwardly directed annular shoulder within the axial limits of the working end of the punch, said recess being adapted to receive and removably retain a stripper button at said working-end of said punch; and a lifting spring coacting between said upper arm and said upper collar to bias said assembly away from said die.

2. A punching device comprising in combination: a C-shaped frame having upper and lower arms with axially aligned bores therein; an apertured die removably secured in the bore of the lower of said arms; a punch and guide assembly reciprocally disposed in the bore of the upper of said arms, said assembly including an elongated punch-guide sleeve, an upper annular collar slidably surrounding the upper end of said sleeve and a lower annular collar surrounding the lower end of said sleeve, a stripping spring means extending about said sleeve and biasing said collars apart, a pair of snap rings each carried by one end of

5

said sleeve and acting against said collars to hold said stripping spring means in partial compression, said collars each having a surface in direct slidable engagement with said upper arm, a punch slidably received within said sleeve and having a head end disposed in and projecting from said upper collar, a manually removable snap ring securing said head end to said upper collar, said punch having a working end adapted to cooperate with said die, said lower collar having a downwardly directed internal recess defining a downwardly directed annular shoulder within the axial limits of the working end of the punch, an annular stripper button received within said recess and having a fit for cooperating with said working end of said punch, and means removably securing said stripper button in said recess; and a lifting spring coacting between said upper arm and said upper collar to bias said assembly away from said die.

3. A punching device comprising in combination: a C-shaped frame having upper and lower arms with axially aligned bores therein; an apertured die removably secured in the bore of the lower of said arms; a punch and guide assembly reciprocally disposed in the bore of the upper of said arms, said assembly including an elongated punch-guide sleeve, an upper annular collar slidably surrounding the upper end of said sleeve and having a shoulder within the bore of the upper arm directed away from said die, and a lower annular collar surrounding the lower end of said sleeve, stripping spring means extending about said sleeve and biasing said collars apart, a pair of snap rings each carried by one end of said sleeve and acting against said collars to hold said stripping spring means in partial compression, said collars each having a surface in direct slidable engagement with said upper arm, a punch slidably received within said sleeve and guided thereby and having a head end disposed in and projecting from said upper collar, a manually removable snap ring securing said head end to said upper collar, said punch having a working end adapted to cooperate with said die, and said lower collar having a downwardly directed internal recess defining a downwardly directed annular shoulder within the axial limits of the working end of the punch, said recess being adapted to receive and removably retain a stripper button at said working-end of said punch; an elongated stop plate disposed on the upper surface of the upper of said arms in overhanging relation to the bore thereof for engagement with said first-mentioned shoulder, said plate being apertured at one end and laterally slotted at the other end; a pair of screws, one extending through the plate aperture and the other through the plate slot and normally securing said plate in fixed position to limit upward movement of said first-mentioned shoulder, the plate slot being so arranged that said screws, when each is only partially released, enable pivoting of said plate about the axis of the aperture thereof while said assembly is in said upper bore to facilitate replacement of said assembly; and a lifting spring coacting between said upper arm and said upper collar to bias said assembly away from said die.

4. A punching device comprising in combination: a C-shaped frame having upper and lower arms with axially aligned bores therein; an apertured die removably secured in the bore of the lower of said arms; a punch and guide assembly reciprocally disposed in the bore of the upper of said arms, said assembly including an elongated punch-guide sleeve, an upper annular collar slidably surrounding the upper end of said sleeve and a lower annular collar surrounding the lower end of said sleeve, stripping spring means extending about said sleeve and biasing said collars apart, a pair of snap rings each carried by one end of said sleeve and acting against said collars to hold said stripping spring means in partial compression, said collars each having an outer surface in direct slidable engagement with said upper arm, a punch slidably received within said sleeve and guided thereby and having a head end disposed in and projecting from said upper collar, a manually removable snap ring secur-

6

ing said head end to said upper collar, said punch having a working end adapted to cooperate with said die, and said lower collar having a downwardly directed internal recess defining a downwardly directed annular shoulder within the axial limits of the working end of the punch, said recess being adapted to receive and removably retain a stripper button at said working end of said punch; said lower collar having means defining a slot opening into said outer surface and extending parallel to the direction of the assembly reciprocation; said upper arm having a circular opening intersecting said bore at said slot; a locating pin disposed in said opening, one end of said pin having a snug slidable fit with said lower collar within said slot, and the other end of said pin having a circular cross section defined by a pair of spaced integral axially directed bifurcations both of which are entirely disposed in said opening, at least one of said bifurcations being resilient and having a free position from which it is returnably deflected by said frame to said circular cross section while in said opening for retaining said pin therein against both angular and linear movement; and a lifting spring coacting between said upper arm and said upper collar to bias said assembly away from said die.

5. A punching device comprising in combination: a C-shaped frame having upper and lower arms with axially aligned bores therein; an apertured die removably secured in the bore of the lower of said arms; a punch and guide assembly reciprocally disposed in the bore of the upper of said arms, said assembly including an elongated punch-guide sleeve, an upper annular collar slidably surrounding the upper end of said sleeve and a lower annular collar surrounding the lower end of said sleeve, stripping spring means extending about said sleeve and biasing said collars apart, a pair of snap rings each carried by one end of said sleeve and acting against said collars to hold said stripping spring means in partial compression, said collars each having an outer surface in direct slidable engagement with said upper arm, a punch slidably received within said sleeve and guided thereby and having a head end disposed in and projecting from said upper collar, a manually removable snap ring securing said head end to said upper collar, said punch having a working end adapted to cooperate with said die, and said lower collar having a downwardly directed internal recess defining a downwardly directed annular shoulder within the axial limits of the working end of the punch, said recess being adapted to receive and removably retain a stripper button at said working end of said punch; said lower collar having means defining a slot opening into said outer surface and extending parallel to the direction of the assembly reciprocation; said upper arm having a circular opening intersecting said bore at said slot; a locating pin having a circular cross section rotatably and slidably disposed in said opening, the inner end of said pin being received within said slot, and having a pair of flat portions snugly and slidably in engagement with opposite walls of said slot, and the other end of said pin having a circular cross section defined by a pair of integral axially directed bifurcations spaced from each other for reception of a rotating tool therebetween and both of which are entirely disposed in said circular opening, at least one of said bifurcations being resilient and having a free position from which it is returnably deflected by said upper arm to said circular cross section while in said opening for retaining said pin therein against both angular and linear movement; and a lifting spring coacting between said upper arm and said upper collar to bias said assembly away from said die.

6. A punching device comprising in combination: a C-shaped frame having upper and lower arms with axially aligned bores therein; an apertured die removably secured in the bore of the lower of said arms; a punch and guide assembly reciprocally disposed in the bore of the upper of said arms, said assembly including an elon-

7

gated punch-guide sleeve, an upper annular collar slidably surrounding the upper end of said sleeve and a lower annular collar surrounding the lower end of said sleeve, stripping spring means extending about said sleeve and biasing said collars apart, a pair of snap rings each carried by one end of said sleeve and acting against said collars to hold said stripping spring means in partial compression, said collars each having an outer surface in direct slidable engagement with said upper arm, a punch slidably received within said sleeve and guided thereby and having a head end disposed in and projecting from said upper collar, a manually removable snap ring securing said head end to said upper collar, said punch having a working end adapted to cooperate with said die, and said lower collar having a downwardly directed internal recess defining a downwardly directed annular shoulder within the axial limits of the working end of the punch, said recess being adapted to receive and removably retain a stripper button at said working end of said punch; at least one of said assembly and said die having a slot on its outer surface extending parallel to the direction of the reciprocation of said assembly; said frame having a circular opening open at both ends, one end of said opening being aligned with said slot; a locating pin disposed in said opening, one end of said pin having a

8

snug fit within said slot, and the other end of said pin having a circular cross section defined by a pair of spaced integral axially directed bifurcations both of which are entirely disposed in said opening, at least one of said bifurcations being resilient and having a free position from which it is returnably deflected by said frame to said circular cross section while in said opening for retaining said pin therein against both angular and linear movement; and a lifting spring coacting between said upper arm and said upper collar to bias said assembly away from said die.

References Cited in the file of this patent

UNITED STATES PATENTS

1,886,177	Gairing -----	Nov. 1, 1932
1,939,478	Whistler -----	Dec. 12, 1933
1,949,817	Stonefield -----	Mar. 6, 1934
2,017,247	Hodge -----	Oct. 15, 1935
2,320,205	Whales -----	May 25, 1943
2,397,325	Newcomb -----	Mar. 26, 1946
2,882,971	Bennett -----	Apr. 21, 1959

FOREIGN PATENTS

411,077	Germany -----	Mar. 10, 1925
---------	---------------	---------------