



US00D775892S

(12) **United States Design Patent**
Smith

(10) **Patent No.:** **US D775,892 S**

(45) **Date of Patent:** **** Jan. 10, 2017**

(54) **BLENDER CONTAINER**

Primary Examiner — Ricky Pham

(71) Applicant: **SharkNinja Operating LLC**, Newton, MA (US)

(74) *Attorney, Agent, or Firm* — Cantor Colburn LLP

(72) Inventor: **Cory Smith**, Auburndale, MA (US)

(57) **CLAIM**

The ornamental design for a blender container, as shown and described.

(73) Assignee: **SHARKNINJA OPERATING LLC**, Newton, MA (US)

DESCRIPTION

(**) Term: **15 Years**

FIG. 1 is a top, front, left side perspective view of a first embodiment of a blender container showing my new design; FIG. 2 is a front elevational view thereof; FIG. 3 is a rear elevational view thereof; FIG. 4 is a left side elevational view thereof; FIG. 5 is a right side elevational view thereof; FIG. 6 is a top plan view thereof; FIG. 7 is a bottom plan view thereof; FIG. 8 is a top, front, left side perspective view of a second embodiment thereof; FIG. 9 is a front elevational view of FIG. 8; FIG. 10 is a rear elevational view of FIG. 8; FIG. 11 is a left side elevational view of FIG. 8; FIG. 12 is a right side elevational view of FIG. 8; FIG. 13 is a top plan view of FIG. 8; FIG. 14 is a bottom plan view of FIG. 8; FIG. 15 is a top, front, left side perspective view of a third embodiment thereof; FIG. 16 is a front elevational view of FIG. 15; FIG. 17 is a rear elevational view of FIG. 15; FIG. 18 is a left side elevational view of FIG. 15; FIG. 19 is a right side elevational view of FIG. 15; FIG. 20 is a top plan view of FIG. 15; FIG. 21 is a bottom plan view of FIG. 15; FIG. 22 is a top, front, left side perspective view of a fourth embodiment thereof; FIG. 23 is a front elevational view of FIG. 22; FIG. 24 is a rear elevational view of FIG. 22; FIG. 25 is a left side elevational view of FIG. 22; FIG. 26 is a right side elevational view of FIG. 22; FIG. 27 is a top plan view of FIG. 22; and, FIG. 28 is a bottom plan view of FIG. 22.

(21) Appl. No.: **29/527,273**

(22) Filed: **May 18, 2015**

Related U.S. Application Data

(63) Continuation of application No. 29/484,128, filed on Mar. 6, 2014, now Pat. No. Des. 734,988.

(51) **LOC (10) Cl.** **31-00**

(52) **U.S. Cl.**
USPC **D7/413; D7/376; D7/378**

(58) **Field of Classification Search**
USPC D7/300.1, 372, 376–386, 412–413, 510,
D7/602, 629, 665–666, 669, 679,
693–694

(Continued)

(56) **References Cited**

U.S. PATENT DOCUMENTS

D181,541 S 11/1957 Madl et al.
D185,780 S 8/1959 Tupper

(Continued)

FOREIGN PATENT DOCUMENTS

DK MA 0260 1955 8/1995
DK MA02601955 8/1995
KR 0233885 S 3/1999

OTHER PUBLICATIONS

U.S. Appl. No. 29/484,128, filed Mar. 6, 2014, Smith.

(Continued)

(Continued)

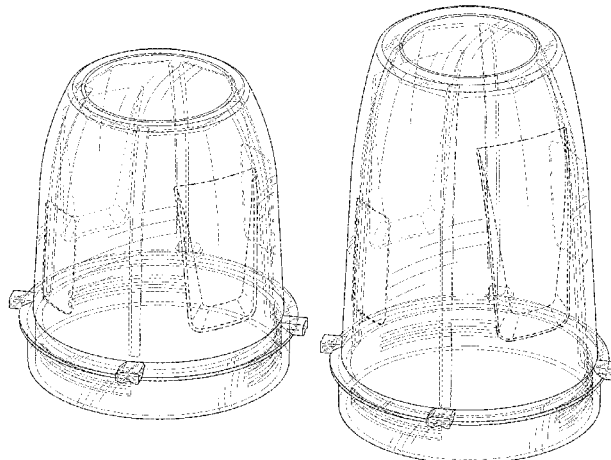

The dash-dot-dash broken lines in the figures define boundaries of the claimed design and form no part of the claimed design.

1 Claim, 28 Drawing Sheets

(58) Field of Classification Search

CPC A21C 1/02; A21C 1/04; A23N 1/00; A23N 1/02; A47G 19/22; A47J 43/04; A47J 43/25; A47J 43/27; A47J 43/042; A47J 43/044; A47J 43/046; A47J 43/075; A47J 43/0722; A47J 43/0727; B01F 3/00; B01F 3/0807; B01F 3/0853; B01F 13/0059; B01F 13/0064; B02C 1/08; B02C 2/04; B02C 4/42; B02C 4/142; B02C 4/143; B02C 4/423; B02C 13/1835; B28C 5/10; B28C 5/12; B28C 5/14; B28C 5/16; B65D 1/46

See application file for complete search history.

(56) References Cited

U.S. PATENT DOCUMENTS

D214,227 S 5/1969 Madl et al.
3,820,692 A 6/1974 Smith et al.
D241,404 S * 9/1976 Mantelet D7/384
D278,963 S 5/1985 Dair et al.
D301,824 S 6/1989 Machuron
D305,503 S 1/1990 Bormioli
D349,423 S 8/1994 Burgel
D400,757 S 11/1998 Hippen et al.
D406,154 S 2/1999 Copland et al.
D416,443 S 11/1999 Kilpatrick et al.
D417,589 S 12/1999 Parker
D417,591 S 12/1999 Roehrig
6,029,568 A 2/2000 Pascotti et al.
D426,423 S 6/2000 Lee
D428,768 S 8/2000 Betras
D431,469 S 10/2000 Solland et al.
D432,865 S 10/2000 Cohen
D438,430 S 3/2001 Gabrhel
D444,344 S 7/2001 Barthelemy et al.
D459,947 S 7/2002 Cheng
D462,236 S 9/2002 Hurlbut
D466,362 S 12/2002 Moore
D471,064 S 3/2003 Renz
D475,582 S 6/2003 To
D478,779 S 8/2003 Stamper, III et al.
D479,949 S 9/2003 Janky
D480,601 S 10/2003 Pettaweebuncha
D487,668 S 3/2004 Sands
D488,672 S 4/2004 Oas
D490,272 S 5/2004 Rohe
D498,642 S 11/2004 Huang
D501,756 S * 2/2005 Nikkhah D7/413
D501,759 S 2/2005 Sands
D507,721 S 7/2005 Schuler
D510,678 S 10/2005 Krasne et al.
D514,884 S * 2/2006 Smith D7/509
D517,862 S 3/2006 Sands
D518,994 S * 4/2006 Lin D7/378
D521,802 S 5/2006 Sands
7,044,051 B2 5/2006 Le Rouzic
D522,304 S 6/2006 Huang
D528,364 S 9/2006 Kolar et al.
D536,216 S 2/2007 Sands
D537,677 S 3/2007 Bresler
D540,124 S 4/2007 Ross
D540,979 S 4/2007 Chen
D547,610 S 7/2007 Edelstein et al.
D548,008 S 8/2007 Lin

D549,043 S * 8/2007 Beesley D7/374
D553,435 S 10/2007 de Groot
D553,904 S 10/2007 Romandy
D554,427 S 11/2007 Sands
D565,353 S 4/2008 Roth et al.
D580,227 S 11/2008 Roth et al.
D580,986 S 11/2008 Farnworth et al.
D587,969 S 3/2009 Gilbert
D617,136 S 6/2010 Bock et al.
D621,206 S 8/2010 Matta et al.
D625,141 S 10/2010 Moore
D631,293 S 1/2011 Ross
D632,133 S 2/2011 Giraud et al.
D632,918 S 2/2011 Gordon
D638,665 S 5/2011 Wu
D644,065 S 8/2011 Llerena
D644,478 S 9/2011 Czach
D654,305 S 2/2012 Gursel et al.
D655,133 S 3/2012 Brinckerhoff et al.
D658,014 S * 4/2012 Miga, Jr. D7/629
D661,547 S 6/2012 Brinckerhoff et al.
D672,618 S * 12/2012 Stamper D7/602
D682,606 S 5/2013 Machovina et al.
D683,590 S * 6/2013 Austin D7/510
D696,063 S 12/2013 Coakley et al.
D697,798 S 1/2014 Sorensen et al.
D698,210 S 1/2014 Lavy et al.
D699,996 S 2/2014 De Leo
D702,999 S 4/2014 Audette et al.
D705,606 S 5/2014 Coakley et al.
D708,903 S 7/2014 Wong
D712,196 S * 9/2014 Ho D7/378
D723,332 S * 3/2015 Steel D7/510
D730,694 S * 6/2015 Elsaden D7/511
D734,988 S * 7/2015 Smith D7/376
D735,530 S * 8/2015 Smith D7/376
D737,629 S * 9/2015 Sands D7/376
D739,674 S * 9/2015 Bergstrom D7/300.1
D744,279 S * 12/2015 Arciero D7/510
D751,344 S * 3/2016 Charlton D7/300.1
D752,390 S * 3/2016 Ksiazek D7/300.1
D754,480 S * 4/2016 Chen D7/509
D754,483 S * 4/2016 Elsaden D7/531
D757,496 S * 5/2016 Julier D7/510
D758,127 S * 6/2016 Zhao D7/392.1
D760,026 S * 6/2016 Smith D7/376
2004/0066705 A1 4/2004 Linz et al.
2005/0047272 A1 3/2005 Sands
2005/0061821 A1* 3/2005 Smith B65D 1/46
220/675
2010/0058940 A1 3/2010 Rivera
2011/0220674 A1* 9/2011 Honeyghan A47G 19/22
220/849

OTHER PUBLICATIONS

U.S. Appl. No. 29/484,129, filed Mar. 6, 2014, Smith.
Notice of Allowance; Design U.S. Appl. No. 29/484,128, filed Mar. 6, 2014; Blender Container; Date Mailed: Mar. 27, 2015; 7 Pages.
Notice of Allowance; Design U.S. Appl. No. 29/484,129, filed Mar. 6, 2014; Blender Container; Date Mailed: Apr. 3, 2015; 6 Pages.
Notice of Allowance; Design U.S. Appl. No. 29/518,186, filed Feb. 20, 2015; Blender Container; Date Mailed: Oct. 7, 2015; 7 Pages.
Requirement for Restriction/Election; Design U.S. Appl. No. 29/518,186, filed Feb. 20, 2015; Blender Container; Date Mailed: Sep. 4, 2015; 6 Pages.
Sunbeam Kitchen Assistant—Model: 2774; Supplied by Japanese Patent Office Action Jan. 5, 2015; URL: http://www.sunbeam.com/productdetail.aspx?section=kitchen&cid=1684&pid=4936; 2 Pages.
Supplemental Notice of Allowance; Design U.S. Appl. No. 29/518,186, filed Feb. 20, 2015; Blender Container; Date Mailed: Apr. 27, 2016; 5 Pages.

* cited by examiner

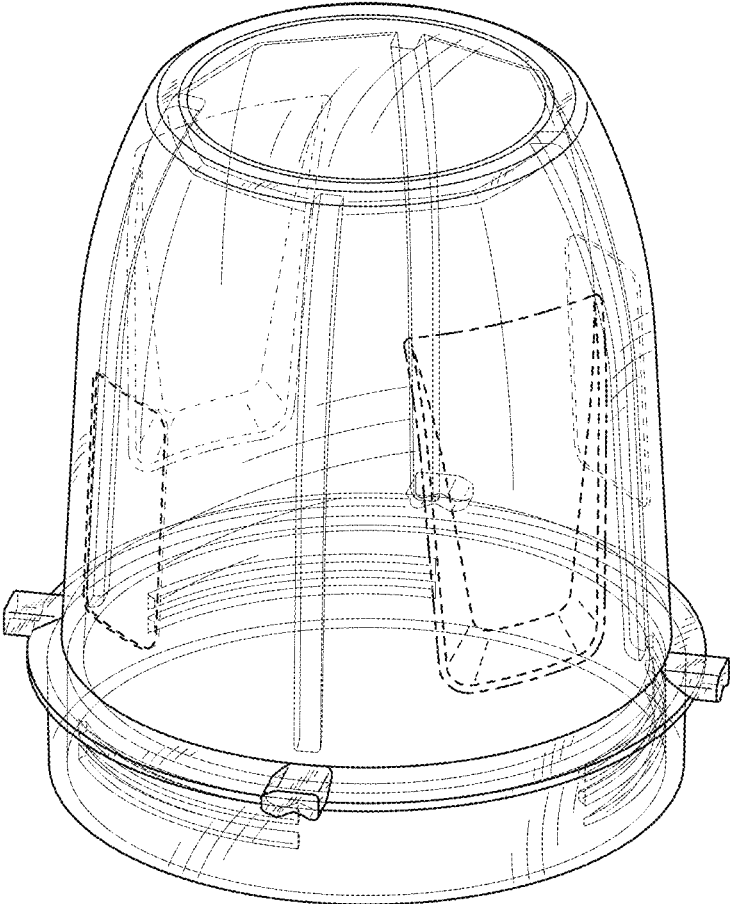

FIG. 1

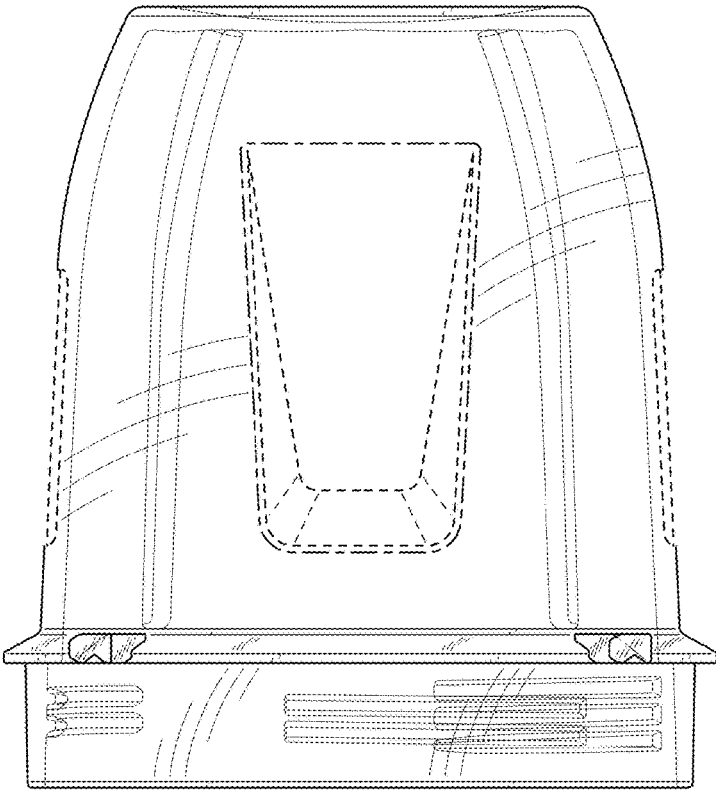

FIG. 2

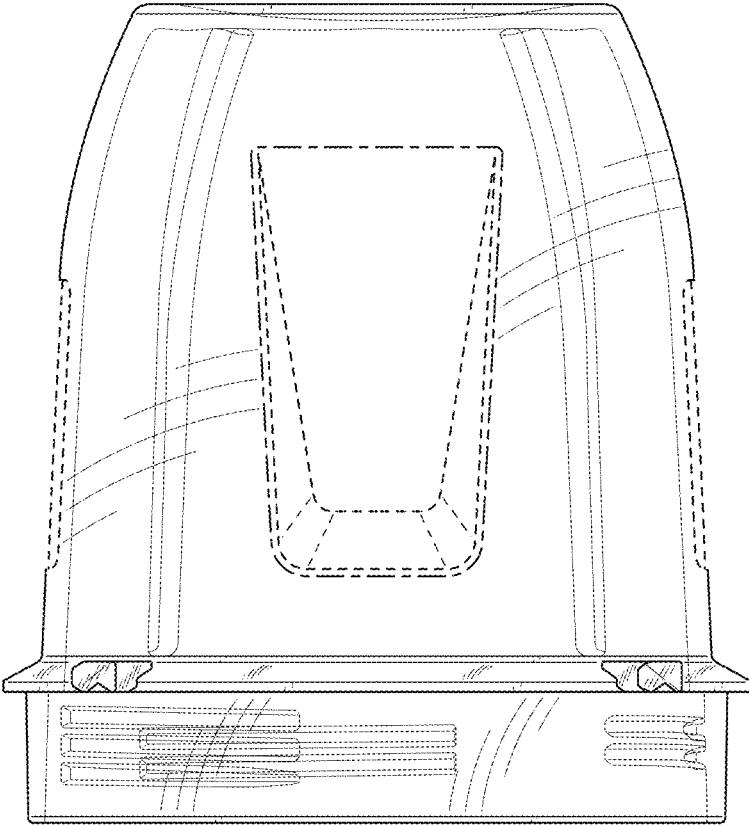

FIG. 3

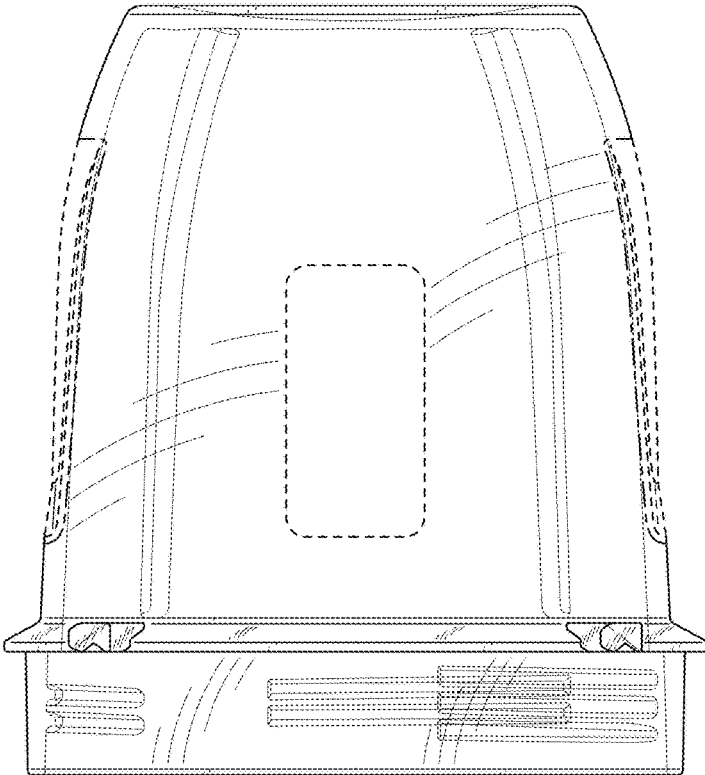

FIG. 4

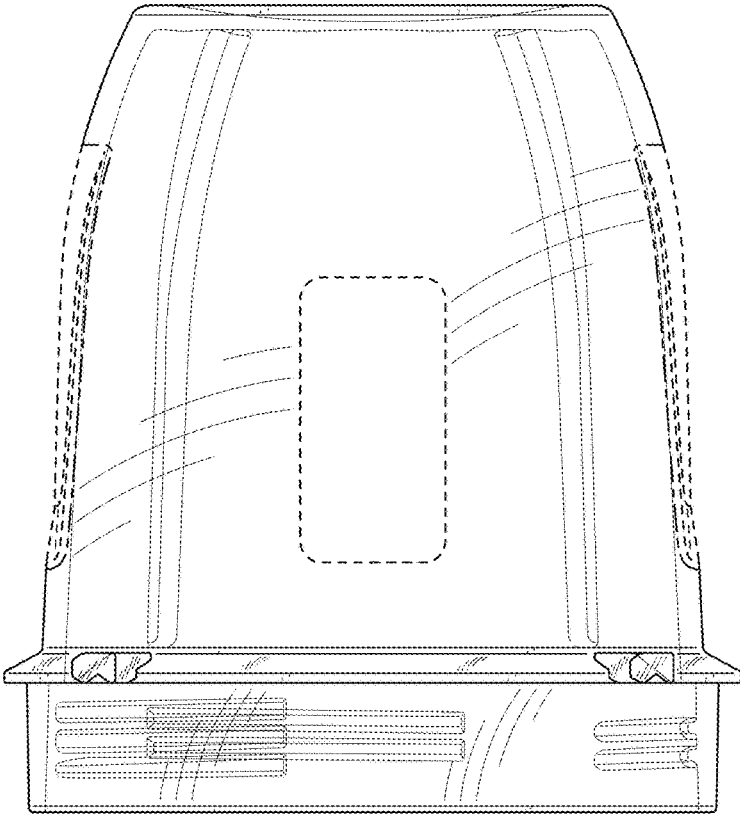

FIG. 5

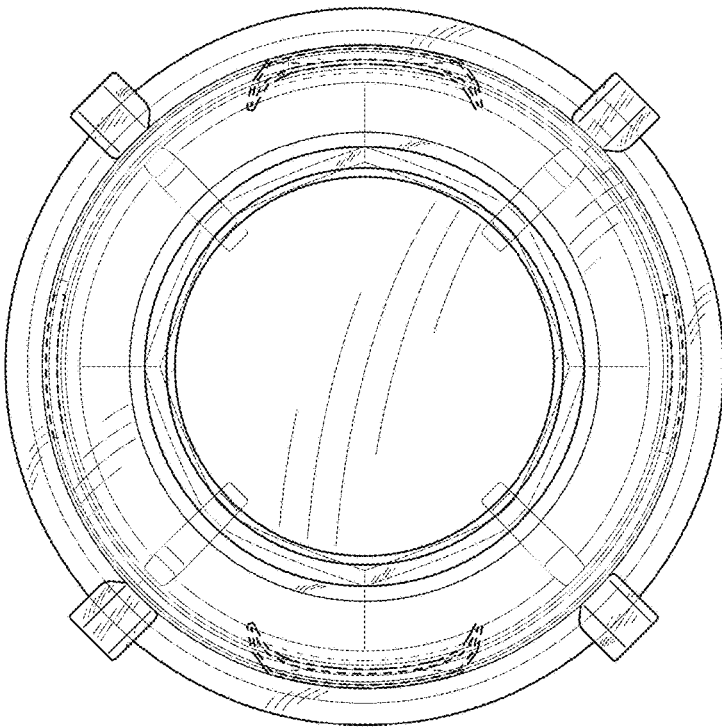

FIG. 6

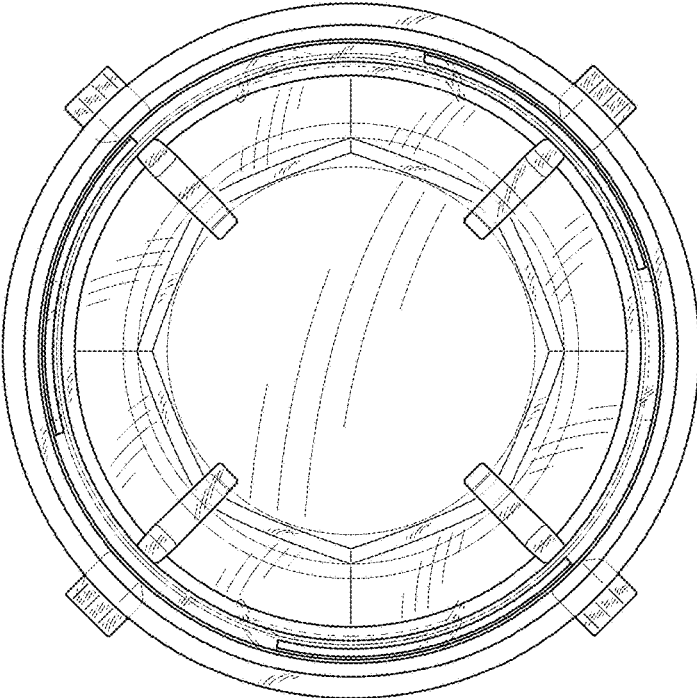

FIG. 7

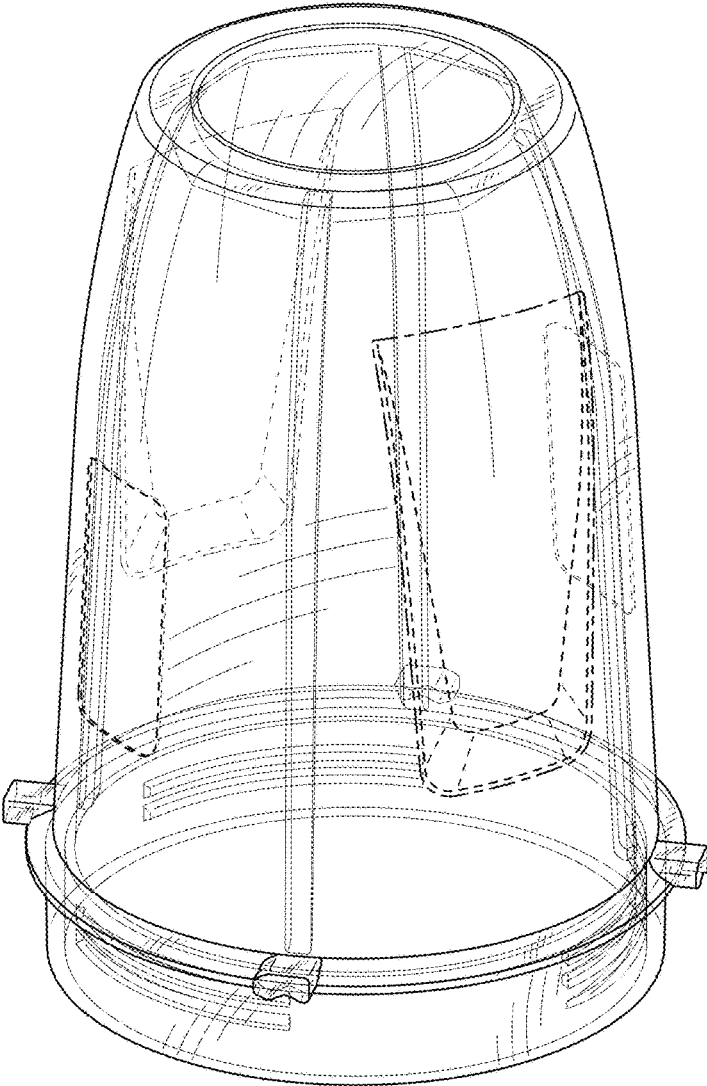

FIG. 8

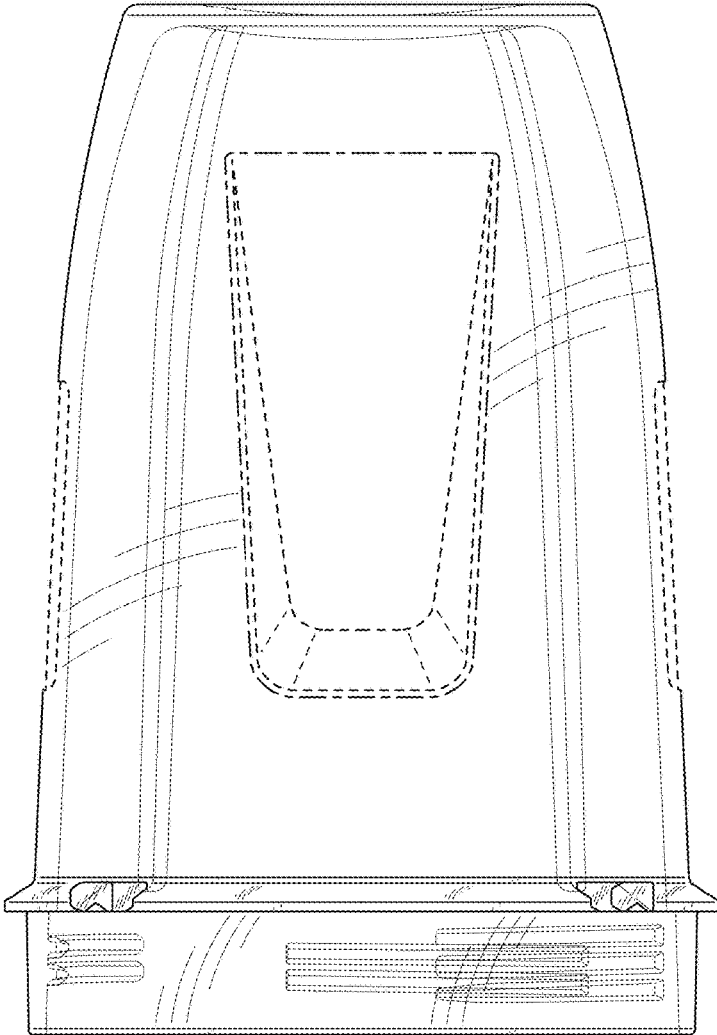

FIG. 9

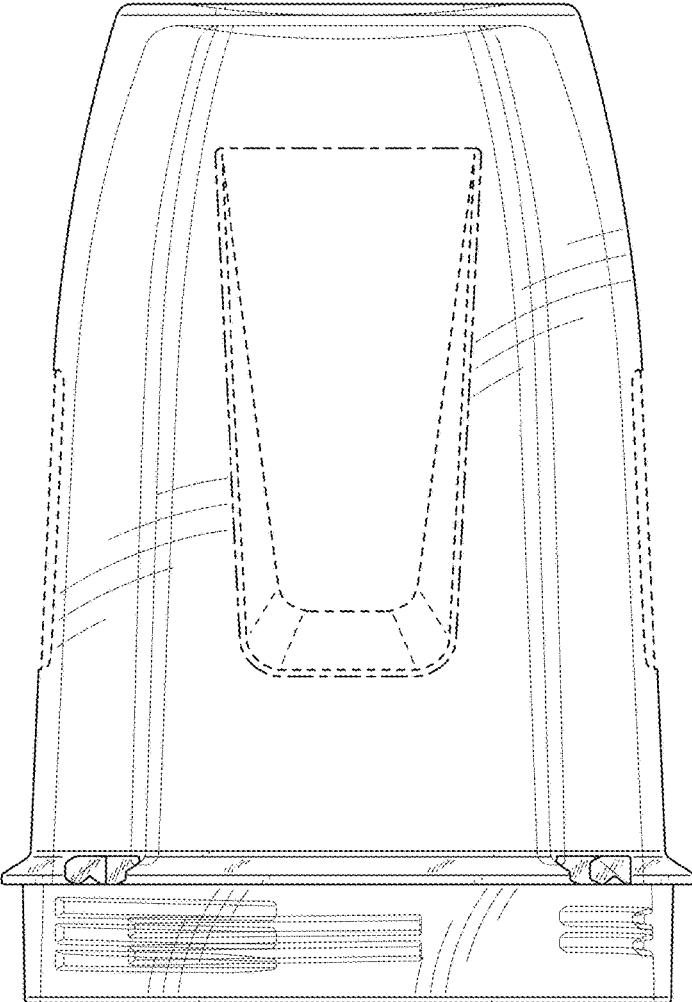

FIG. 10

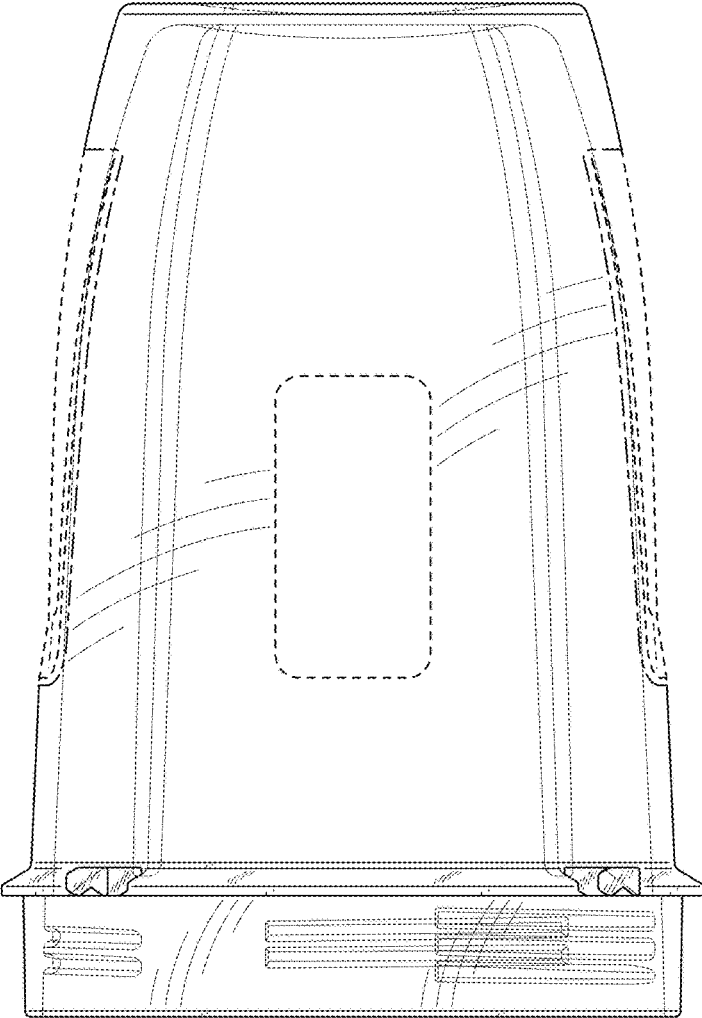

FIG. 11

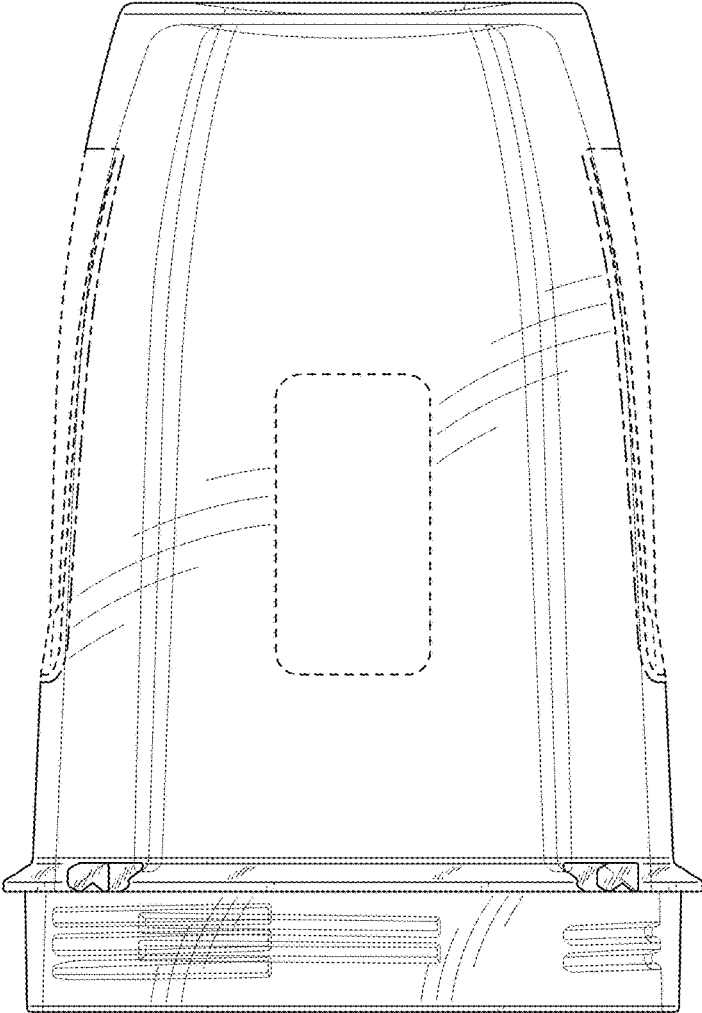

FIG. 12

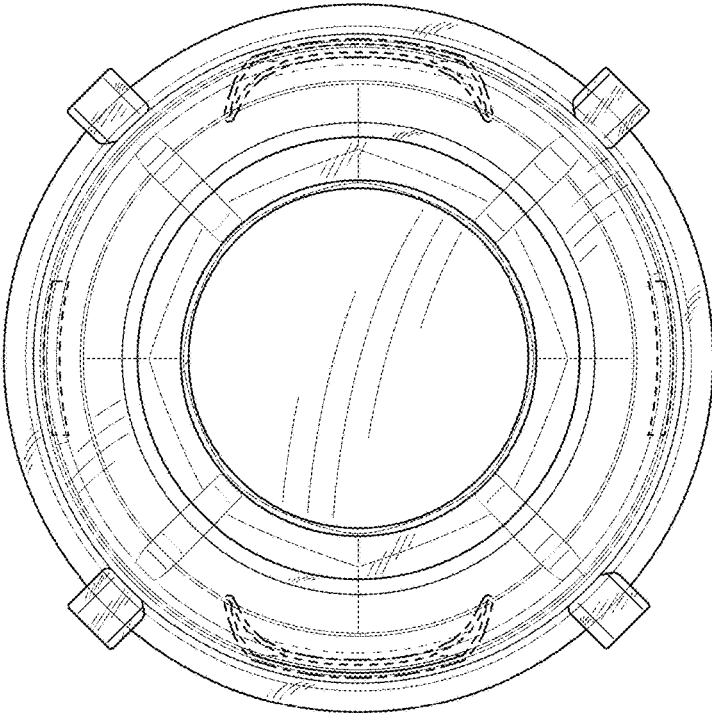

FIG. 13

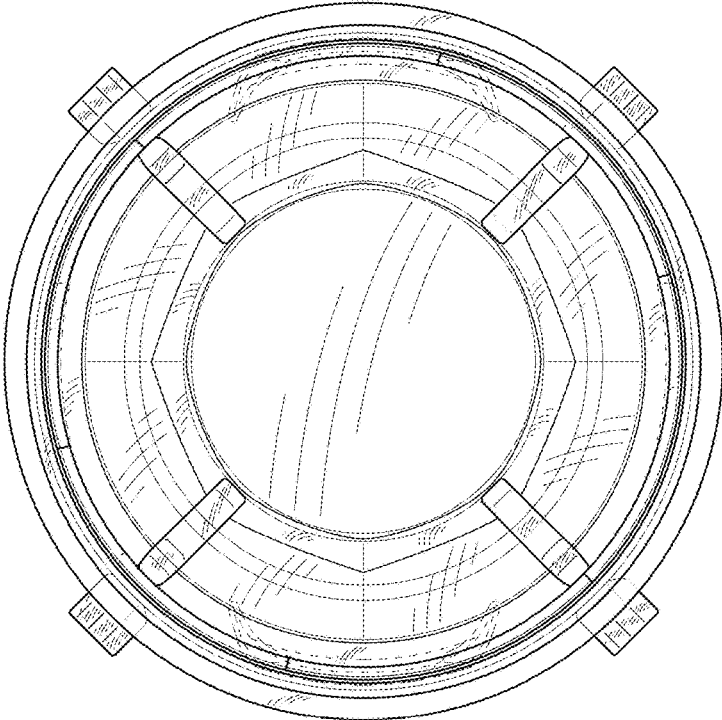

FIG. 14

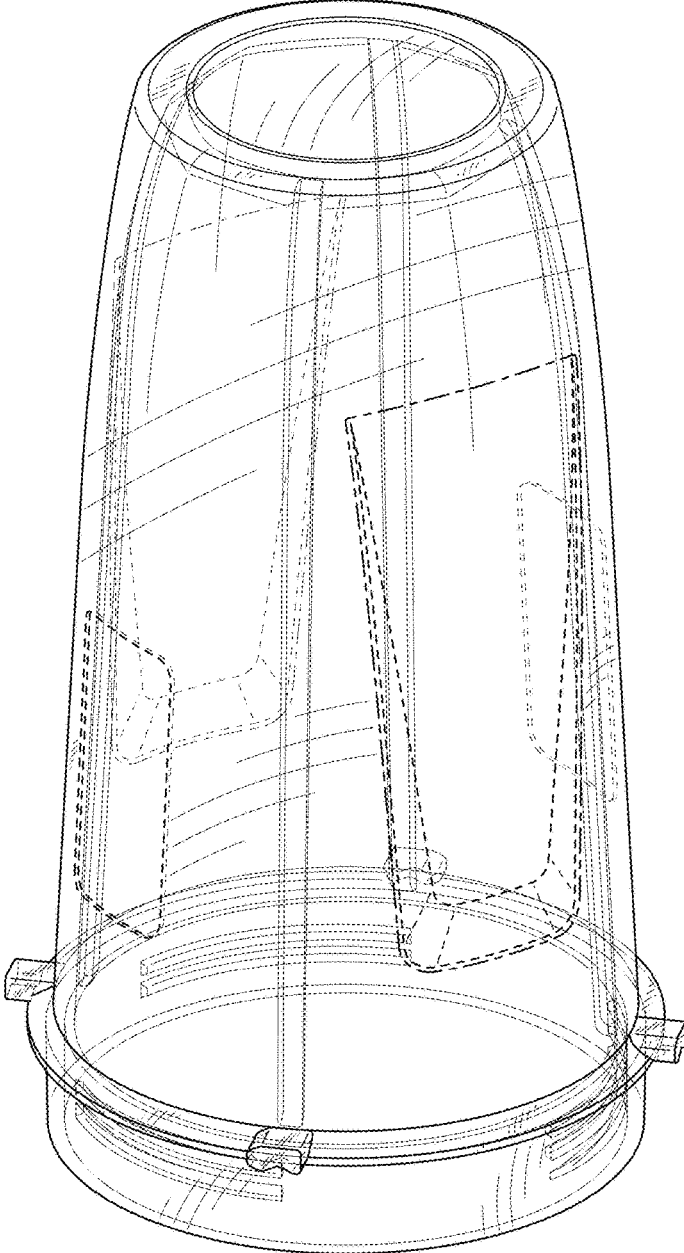

FIG. 15

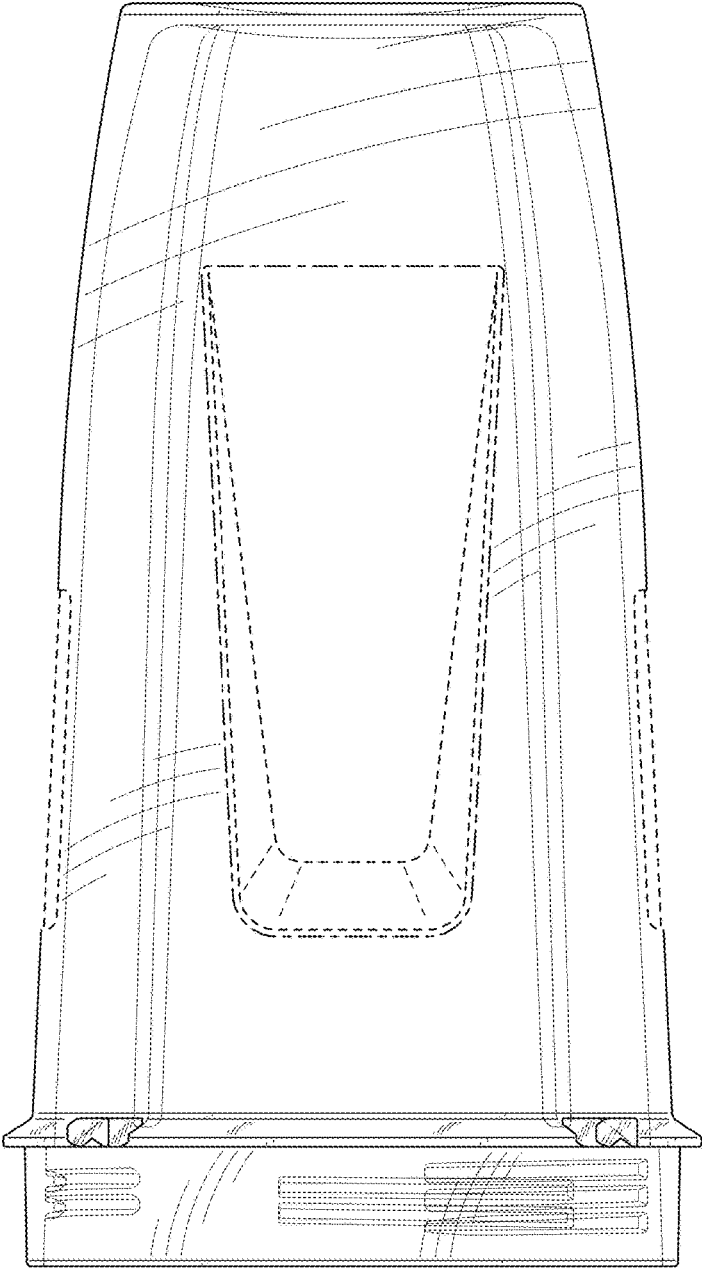

FIG. 16

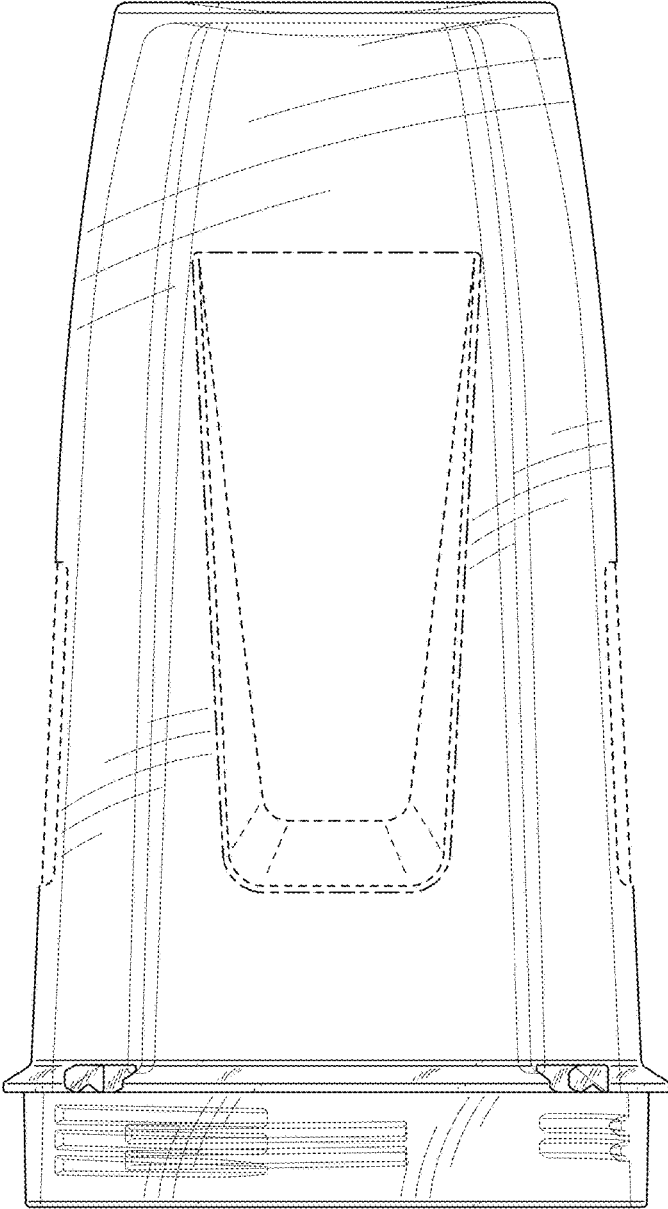

FIG. 17

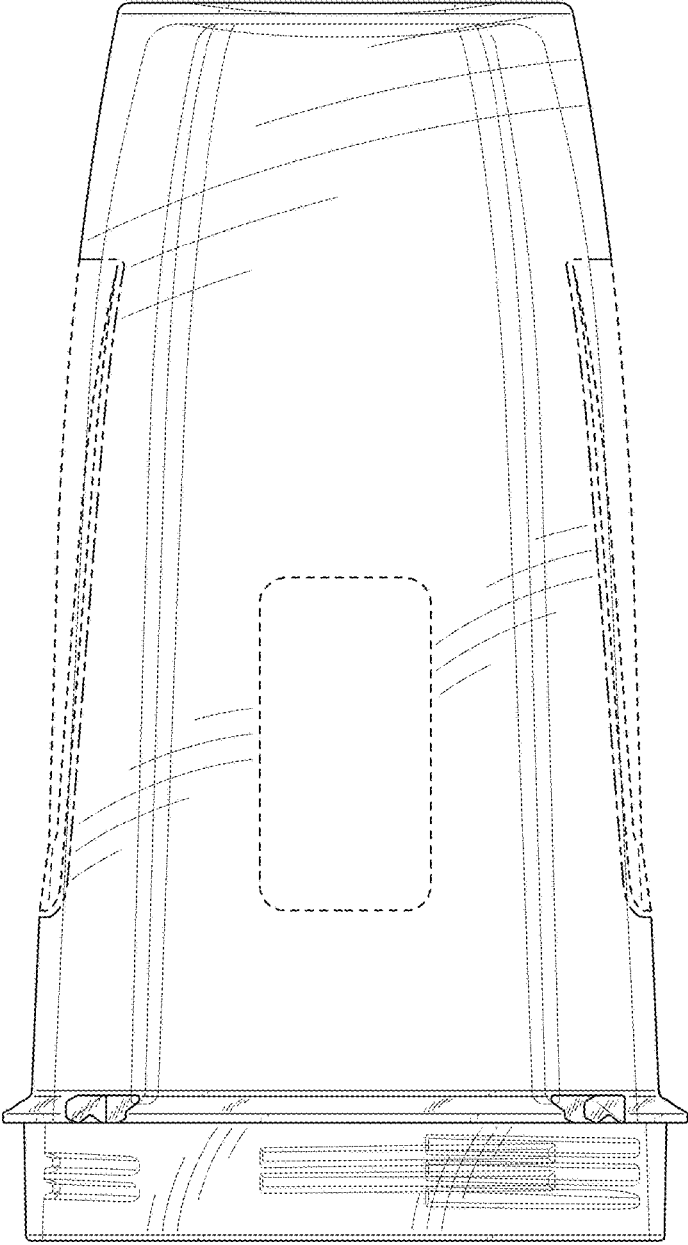

FIG. 18

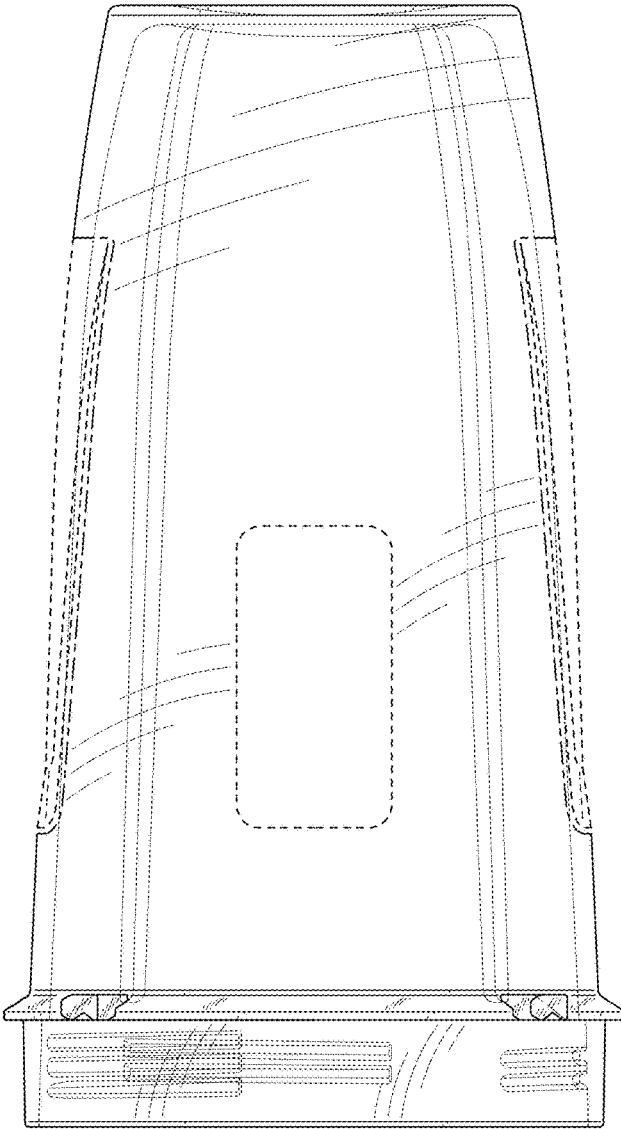

FIG. 19

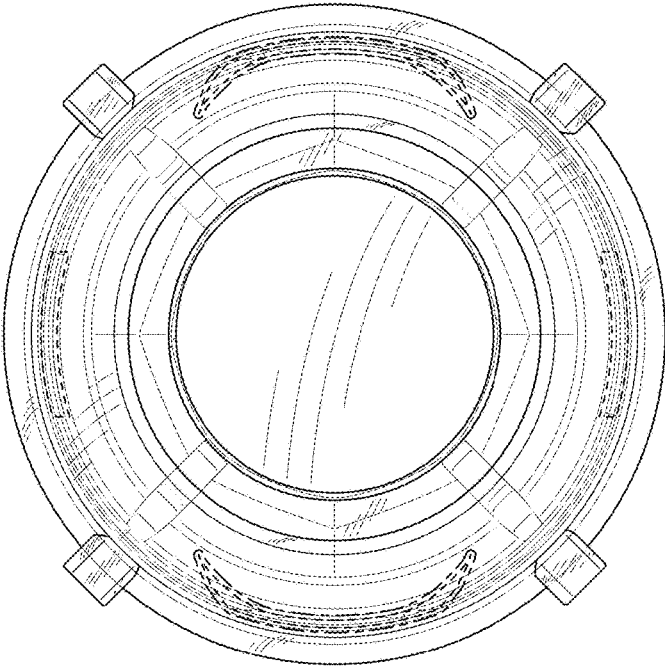

FIG. 20

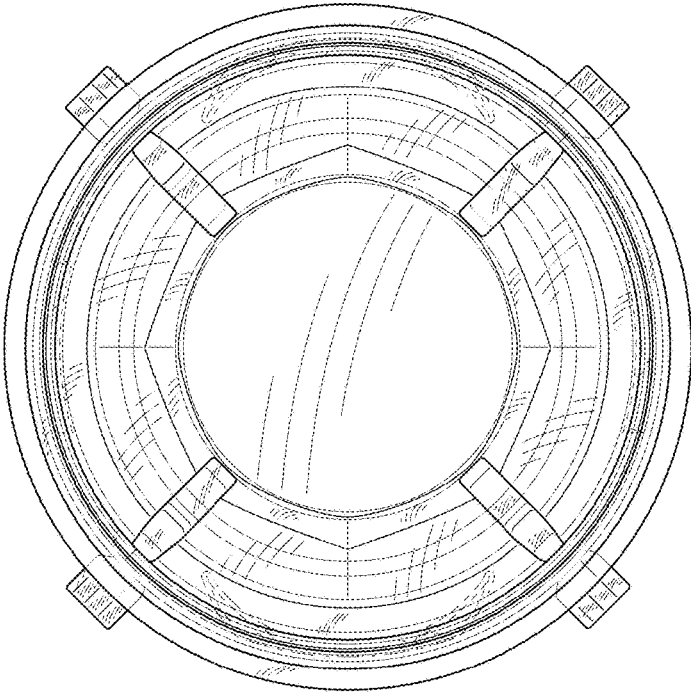

FIG. 21

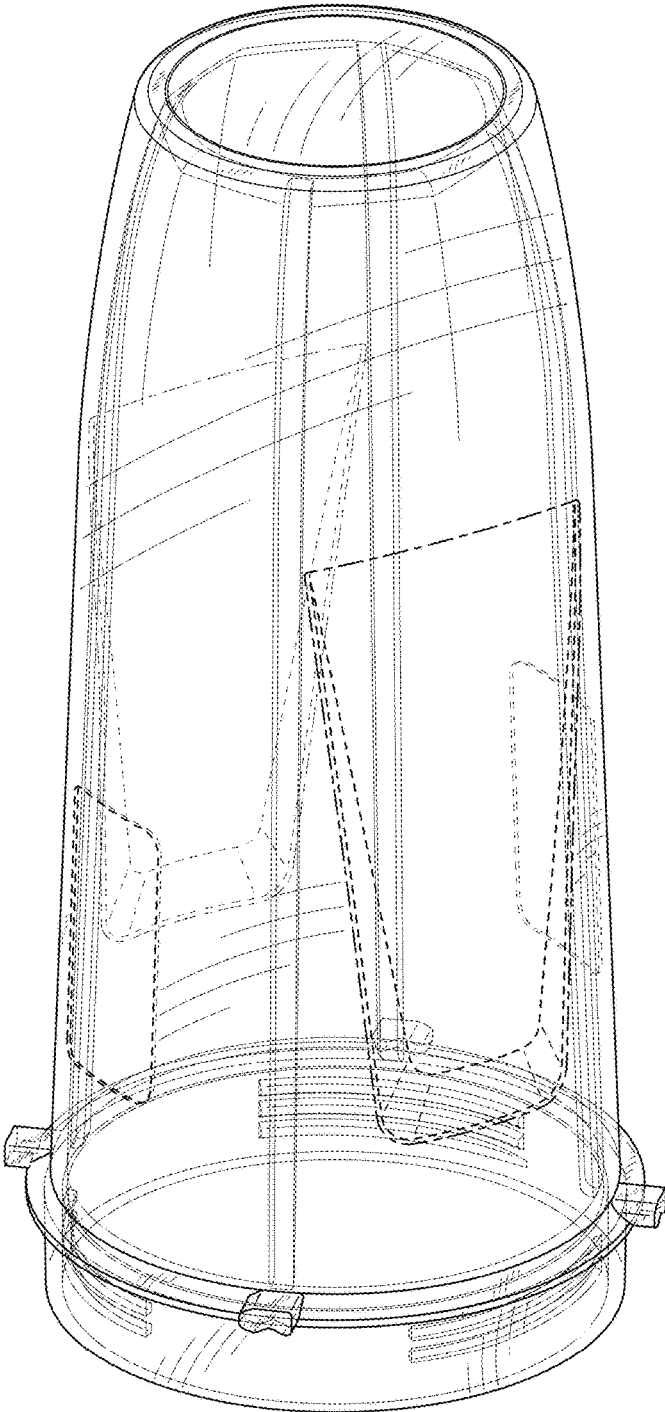

FIG. 22

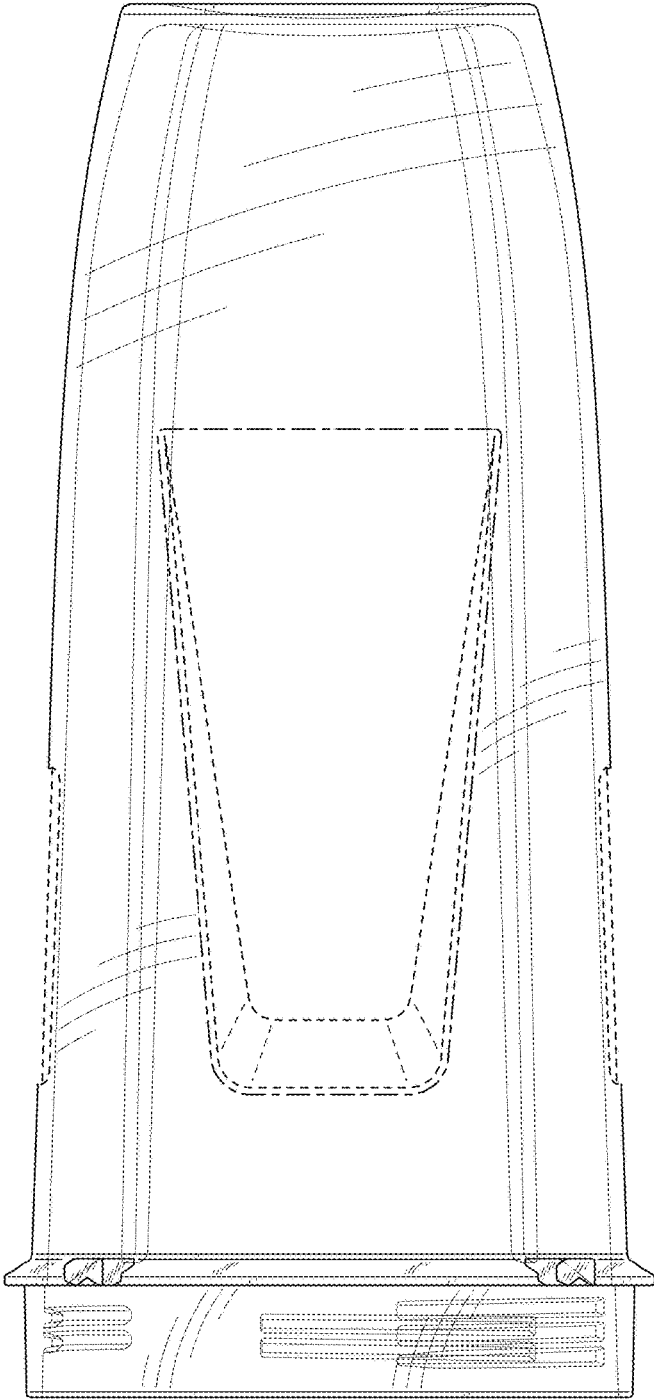

FIG. 23

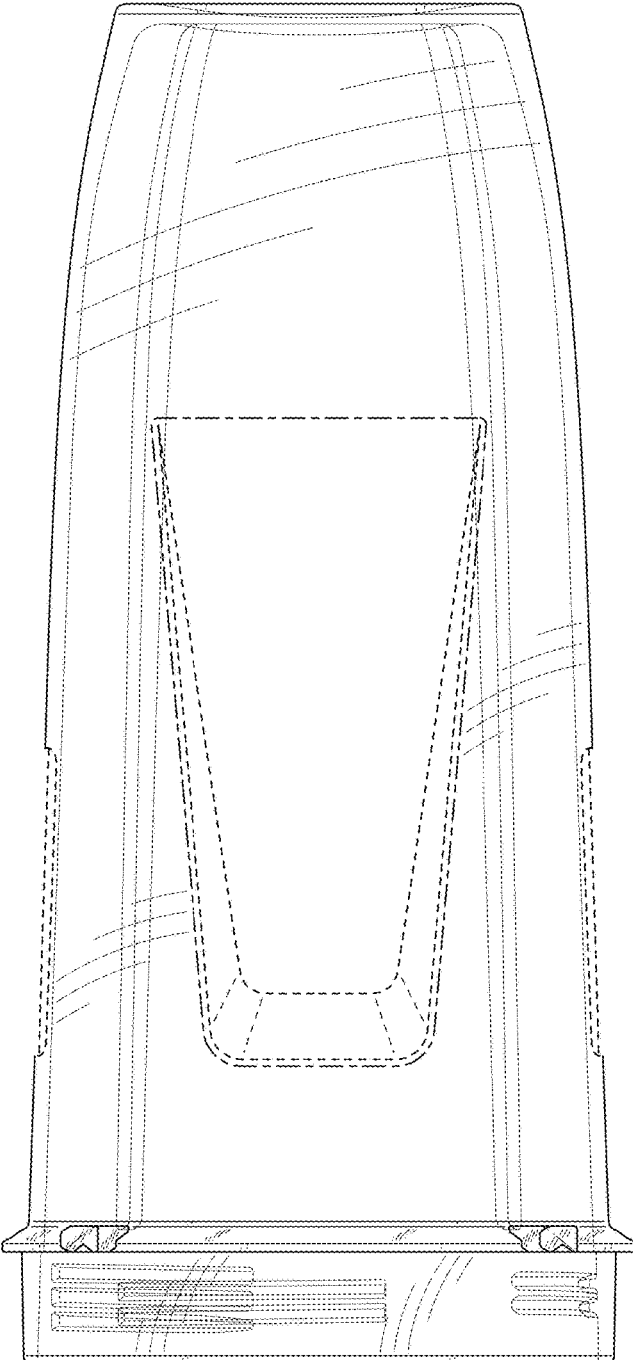

FIG. 24

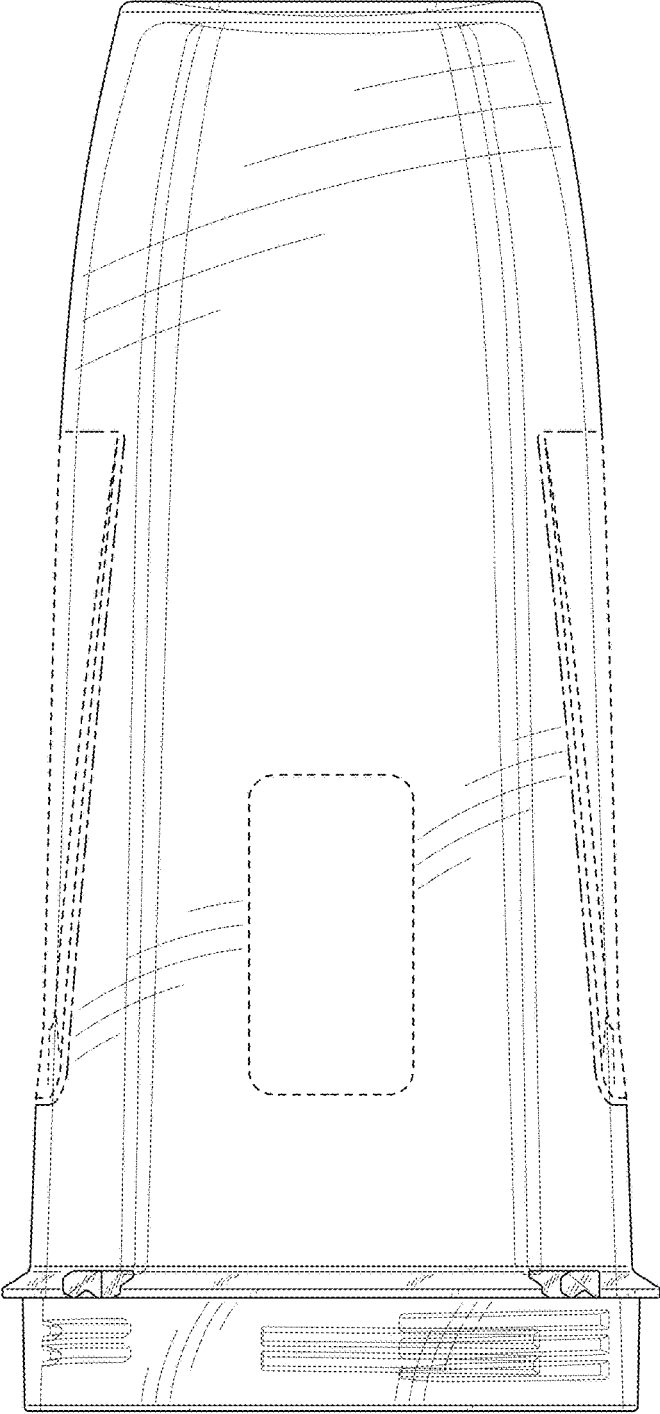

FIG. 25

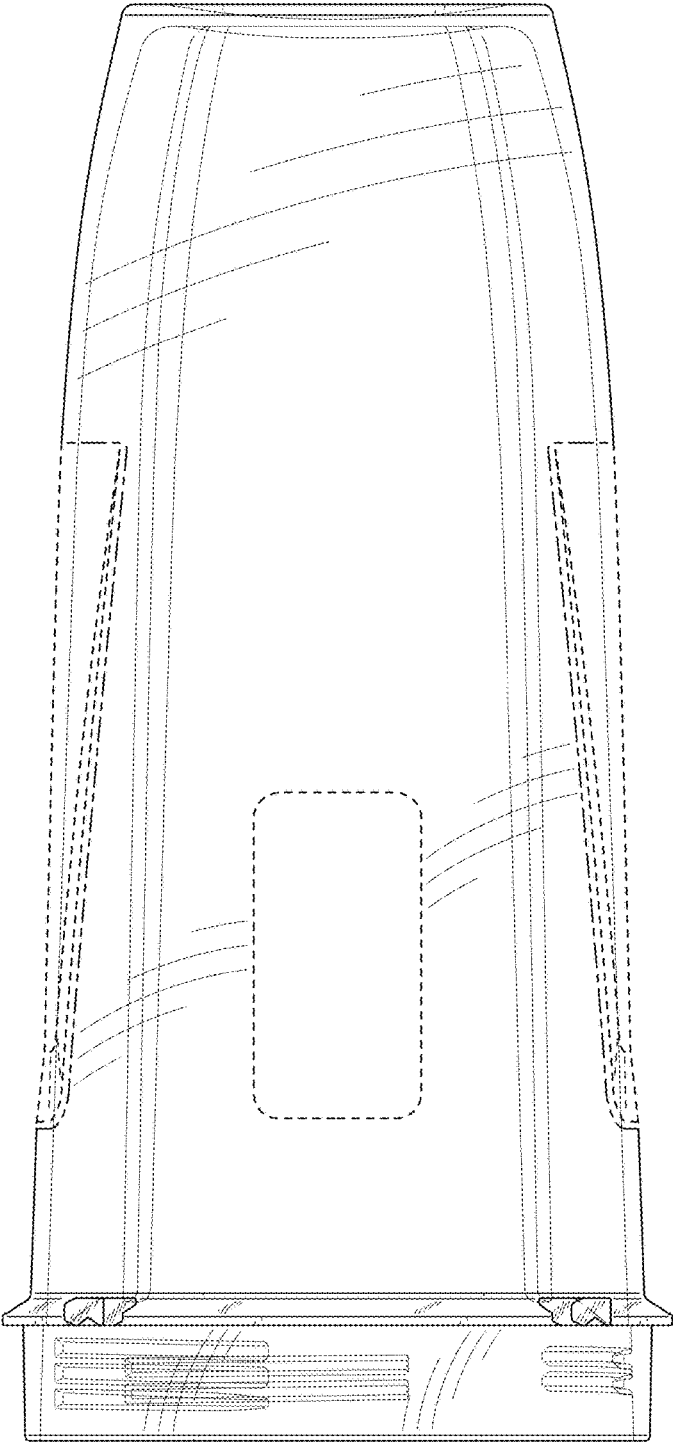

FIG. 26

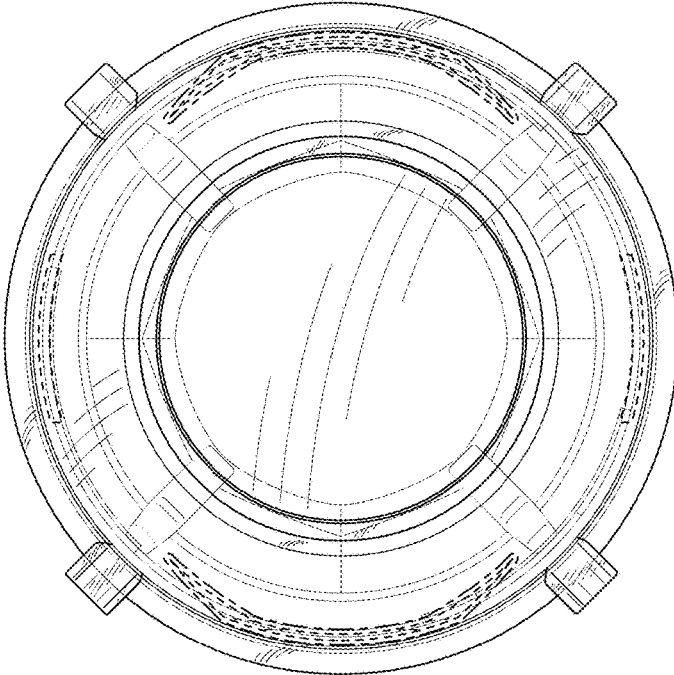

FIG. 27

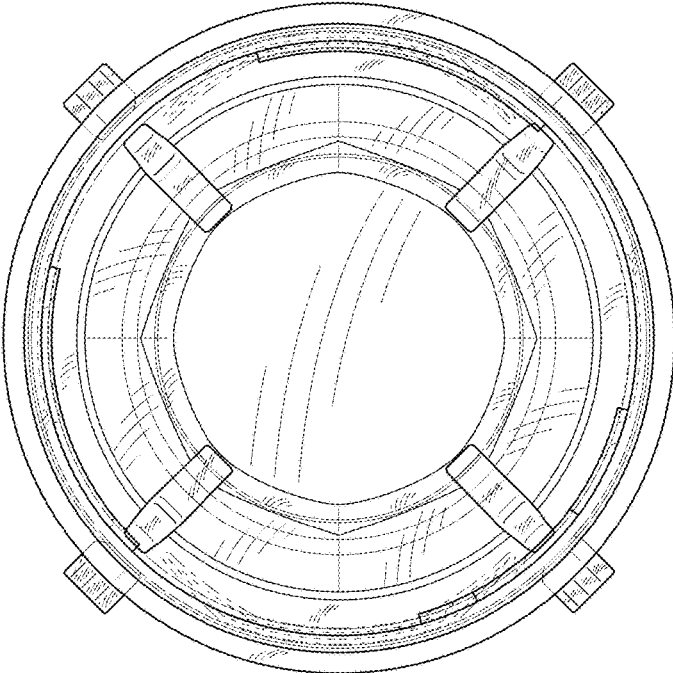

FIG. 28