



US00D907383S

(12) **United States Design Patent** (10) **Patent No.:** **US D907,383 S**
Deevers et al. (45) **Date of Patent:** **** Jan. 12, 2021**

(54) **CHAIR WITH UPHOLSTERED BACK**

(71) Applicant: **Steelcase Inc.**, Grand Rapids, MI (US)

(72) Inventors: **Nickolaus William Charles Deevers**,
 Holland, MI (US); **Santiago Carral O’Gorman**, Grand Rapids, MI (US);
Gary Karsten, Wyoming, MI (US)

(73) Assignee: **Steelcase Inc.**, Grand Rapids, MI (US)

(**) Term: **15 Years**

(21) Appl. No.: **29/693,239**

(22) Filed: **May 31, 2019**

(51) **LOC (13) Cl.** **06-01**

(52) **U.S. Cl.**
 USPC **D6/366**

(58) **Field of Classification Search**
 USPC D6/356, 364, 365, 366, 367, 379, 716,
 D6/716.4, 716.7; D21/521, 695
 CPC A47C 1/03294; A47C 1/034; A47C 1/032;
 A47C 1/031; A47C 3/029; A47C 3/027;
 A47C 3/04; A47C 3/02; A47C 3/12;
 A47C 4/03; A47C 4/04; A47C 5/12;
 A47C 7/029; A47C 7/02; A47C 7/18;
 A47C 7/28; A47C 7/32; A47C 7/38;
 A47C 7/40; A47C 7/44; A47C 7/46;
 A47C 7/54; A47C 7/425; A47C 7/445;
 A47C 31/023; A47C 31/04; B60R
 2/0284; B60R 2/062; B60R 22/001; B60R
 22/24; B60R 22/28; B60R 22/58; B60R
 22/64; B60R 22/68; B60R 22/80; B60R
 22/99; B60R 22/245; B60R 22/643; B60R
 22/646; B60R 22/665; B60R 22/686;
 B60R 22/688; B60R 22/803; B60R
 22/986; B60R 22/914; B60R 22/995;
 F16B 2/08; F16B 45/00; Y10S 297/01;
 A47D 13/10

See application file for complete search history.

2,726,713 A 12/1955 Turner
 3,559,978 A 2/1971 Molt
 3,652,809 A 3/1972 Dickopp et al.
 3,653,233 A 4/1972 Titone
 3,709,559 A 1/1973 Rowland
 3,720,568 A 3/1973 Rowland
 3,724,402 A 4/1973 Thyberg et al.
 3,767,261 A 10/1973 Rowland
 3,774,967 A 11/1973 Rowland
 3,843,477 A 10/1974 Rowland
 3,948,558 A 4/1976 Obermeier et al.
 D276,575 S 12/1984 Helmholdt
 D276,576 S 12/1984 Helmholdt
 4,502,728 A 3/1985 Sheldon et al.
 D279,244 S 6/1985 Bergquist
 4,574,100 A 3/1986 Mercer
 4,634,178 A 1/1987 Carney
 4,668,557 A 5/1987 Lakes
 4,680,215 A 7/1987 Mercer
 4,718,724 A 1/1988 Quinton et al.
 D295,925 S 5/1988 Uredat-Neuhoff
 4,889,384 A 12/1989 Sulzer
 5,154,485 A 10/1992 Fleishman
 5,269,631 A 12/1993 Mercer et al.
 D345,867 S 4/1994 Narita
 D351,291 S 10/1994 Volkle
 5,447,357 A 9/1995 Dauphin
 5,711,575 A 1/1998 Hand et al.
 5,747,140 A 5/1998 Heerklotz
 5,791,933 A 8/1998 Saka et al.
 5,863,095 A 1/1999 Rivard et al.
 5,871,258 A 2/1999 Battey et al.
 D408,161 S 4/1999 Caruso
 5,934,758 A 8/1999 Ritche et al.
 5,951,109 A 9/1999 Roslund, Jr. et al.
 5,975,634 A 11/1999 Knoblock et al.
 6,035,901 A 3/2000 Stumpf et al.
 6,062,649 A 5/2000 Nagel et al.
 6,079,785 A 6/2000 Peterson et al.
 D437,501 S 2/2001 Rehmert et al.
 6,189,972 B1 2/2001 Chu et al.
 D446,954 S 8/2001 Sottsass
 6,286,900 B1 9/2001 Roark
 D449,172 S 10/2001 VanDeRiet et al.
 6,299,248 B1 10/2001 Gennaro et al.
 D449,938 S 11/2001 Vanderiet et al.
 D451,293 S 12/2001 Su
 6,343,839 B1 2/2002 Simons, Jr.
 6,354,662 B1 3/2002 Su
 6,361,110 B2 3/2002 Roslund, Jr. et al.
 D455,571 S 4/2002 VanDeRiet et al.
 D456,160 S 4/2002 VanDeRiet et al.
 D456,164 S 4/2002 VanDeRiet et al.

(56) **References Cited**
 U.S. PATENT DOCUMENTS
 590,045 A 9/1897 Mauchain
 2,678,685 A 5/1954 Volsk

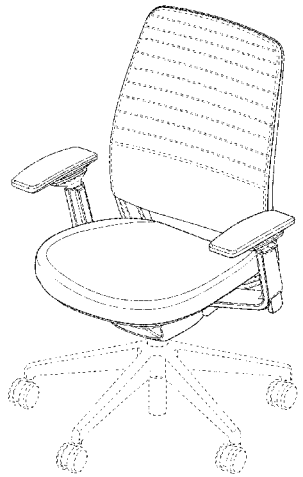

US D907,383 S

D456,627 S	5/2002	Pearce et al.	7,887,131 B2	2/2011	Chadwick et al.	
D457,739 S	5/2002	Pearce et al.	7,931,257 B2	4/2011	VanDeRiet et al.	
D460,870 S	7/2002	VanDeRiet et al.	D637,423 S	5/2011	Behar et al.	
6,412,593 B1	7/2002	Jones	D637,838 S	5/2011	Piretti	
6,419,318 B1	7/2002	Albright	D639,091 S	6/2011	Behar et al.	
D463,174 S	9/2002	Chu	D643,641 S *	8/2011	Figuroa	D6/366
6,471,294 B1	10/2002	Dammermann et al.	D643,642 S *	8/2011	Figuroa	D6/366
D471,042 S	3/2003	Schmitz et al.	7,997,652 B2	8/2011	Roslund et al.	
6,550,866 B1	4/2003	Su	D644,862 S *	9/2011	Gaschy	D6/716
6,568,760 B2	5/2003	Davis et al.	D647,738 S	11/2011	Chen	
6,572,190 B2	6/2003	Koepke et al.	D648,554 S	11/2011	Smith	
6,575,530 B1	6/2003	Fischer et al.	D650,206 S	12/2011	Behar et al.	
6,598,937 B2	7/2003	Caruso et al.	D652,647 S	1/2012	Schaack	
6,626,497 B2	9/2003	Nagamitsu et al.	D652,657 S	1/2012	Behar et al.	
6,644,752 B2	11/2003	Takata	D653,061 S	1/2012	Behar et al.	
6,688,698 B1	2/2004	Chou et al.	D654,291 S	2/2012	Pearson et al.	
D487,197 S	3/2004	Edwards et al.	D655,522 S	3/2012	Czumaj-Bront et al.	
6,709,060 B1	3/2004	Su	8,128,175 B2	3/2012	Groelsma et al.	
6,726,285 B2	4/2004	Caruso et al.	D657,166 S	4/2012	Behar et al.	
D489,191 S	5/2004	Ma	8,157,329 B2	4/2012	Masoud et al.	
6,729,691 B2	5/2004	Koepke et al.	D660,056 S	5/2012	Diffrient	
6,733,080 B2	5/2004	Stumph et al.	D660,612 S	5/2012	Smith	
D494,792 S	8/2004	Schmitz et al.	D660,622 S	5/2012	Su	
6,805,405 B2	10/2004	Koo	8,172,332 B2	5/2012	Masunaga et al.	
D499,564 S	12/2004	Meda	8,186,761 B2	5/2012	Brill et al.	
D500,211 S	12/2004	Koch et al.	8,191,970 B2	6/2012	Igarashi et al.	
6,837,546 B2	1/2005	VanDeRiet et al.	8,210,611 B2	7/2012	Aldrich et al.	
6,874,852 B2	4/2005	Footitt	D665,592 S *	8/2012	Citterio	D6/366
6,890,030 B2	5/2005	Wilkerson et al.	8,246,117 B2	8/2012	Melhuish et al.	
6,957,861 B1	10/2005	Chou et al.	D666,841 S	9/2012	Czumaj-Bront et al.	
6,966,604 B2	11/2005	Stumpf et al.	8,297,708 B2	10/2012	Mizobata et al.	
D513,134 S	12/2005	Asano et al.	D671,330 S	11/2012	Izawa	
6,974,189 B2	12/2005	Machael et al.	D673,385 S	1/2013	Lu	
D513,457 S	1/2006	Asano et al.	D673,394 S	1/2013	Hurford	
6,981,743 B2	1/2006	Edwards et al.	D680,345 S	4/2013	Xingchang	
7,004,543 B2	2/2006	Caruso et al.	D683,150 S	5/2013	Smith et al.	
D521,755 S	5/2006	Kinoshita et al.	8,436,508 B2	5/2013	Kornbluh et al.	
7,059,682 B2	6/2006	Caruso et al.	8,449,037 B2	5/2013	Behar et al.	
7,097,247 B2	8/2006	Batthey	D683,552 S	6/2013	Wu	
7,213,886 B2	5/2007	Schmitz et al.	D686,833 S	7/2013	Chan	
7,234,773 B2	6/2007	Raftery et al.	D688,055 S	8/2013	Baldanzi	
7,247,265 B2	7/2007	Alderson et al.	8,534,648 B2	9/2013	Coffield et al.	
7,249,802 B2	7/2007	Schmitz et al.	D695,537 S	12/2013	Geelen	
7,252,870 B2	8/2007	Anderson et al.	8,602,494 B2	12/2013	Cvek	
7,275,793 B2	10/2007	Fujita et al.	8,652,602 B1	2/2014	Dolla	
7,281,764 B2	10/2007	Thole	D701,068 S	3/2014	Usumoto et al.	
7,293,833 B2	11/2007	Takeuchi et al.	D703,458 S	4/2014	Nakamura et al.	
7,303,232 B1	12/2007	Chen	D703,459 S	4/2014	Nakamura et al.	
D558,995 S	1/2008	Igarashi	D704,487 S	5/2014	Smith	
D564,264 S	3/2008	Smith et al.	D704,488 S	5/2014	Massaud	
7,344,194 B2	3/2008	Maier et al.	D704,945 S	5/2014	Massaud	
7,347,495 B2	3/2008	Beyer et al.	D705,561 S	5/2014	Massaud	
D571,568 S	6/2008	Overthun et al.	D706,547 S	6/2014	Smith	
7,406,733 B2	8/2008	Coffield et al.	8,752,896 B2	6/2014	Takeuchi et al.	
7,419,215 B2	9/2008	Wilkerson et al.	D708,466 S	7/2014	Massaud	
7,441,758 B2	10/2008	Coffield et al.	D710,640 S	8/2014	Usumoto et al.	
7,455,365 B2	11/2008	Caruso et al.	D717,555 S	11/2014	Massaud	
7,472,962 B2	1/2009	Caruso et al.	8,926,016 B2	1/2015	Behar et al.	
7,484,802 B2	2/2009	Beyer et al.	D724,367 S	3/2015	Sander	
D591,969 S	5/2009	Overthun et al.	8,967,724 B2	3/2015	Batthey et al.	
D597,331 S *	8/2009	Neil	D726,431 S	4/2015	Ye	D6/366
7,568,768 B1	8/2009	Tsai	D728,292 S	5/2015	Ooki	
D600,052 S	9/2009	Smith et al.	9,095,217 B2	8/2015	Oda	
D600,931 S	9/2009	Pearson	D741,099 S	10/2015	Igarashi et al.	
7,594,700 B2	9/2009	Stumpf et al.	9,155,393 B2	10/2015	Hurford et al.	
7,604,298 B2	10/2009	Peterson et al.	D742,674 S	11/2015	Wilkinson et al.	
D604,527 S	11/2009	Ooki et al.	9,192,237 B2	11/2015	Bachar	
D607,653 S	1/2010	Wilkinson	9,211,014 B2	12/2015	Schmitz et al.	
7,647,714 B2	1/2010	Coffield et al.	9,301,615 B2	4/2016	Behar et al.	
D609,482 S	2/2010	Englisch et al.	9,332,851 B2	5/2016	Machael et al.	
7,712,834 B2	5/2010	Knoblock et al.	D763,587 S	8/2016	Neil	
7,731,295 B2	6/2010	Lin	D763,612 S	8/2016	Goetz	
7,740,321 B2	6/2010	Brill et al.	D767,318 S	9/2016	Kubryk	
D622,985 S *	9/2010	Kubryk	9,486,079 B2	11/2016	Romero	D6/716
7,794,017 B2	9/2010	Kan et al.	D773,872 S	12/2016	Kim	
7,794,022 B2	9/2010	Caruso et al.	9,578,969 B1	2/2017	Su	
7,841,665 B2	11/2010	Geister et al.	D782,240 S	3/2017	Wada	
7,857,388 B2	12/2010	Bedford et al.	9,603,451 B2	3/2017	Masunaga et al.	
7,866,750 B2	1/2011	Bock	D785,353 S	5/2017	Zhou	

9,661,930	B2	5/2017	Norman	
D789,129	S	6/2017	Fromme-Ruthmann	
D792,120	S	7/2017	Webb	
D792,717	S	7/2017	Webb	
D795,602	S *	8/2017	Neil	D6/366
D799,843	S *	10/2017	Chen	D6/366
D801,741	S	11/2017	Zhu	
D802,953	S *	11/2017	Meda	D6/366
D816,362	S *	5/2018	Su	D6/366
D825,971	S *	8/2018	Scagnellato	D6/716
D846,294	S *	4/2019	Peterson	D6/366
D852,525	S *	7/2019	Peterson	D6/366
D869,872	S *	12/2019	Deevers	D6/366
D873,576	S *	1/2020	Engelhardt	D6/366
2002/0021040	A1	2/2002	Caruso et al.	
2004/0140701	A1	7/2004	Schmitz et al.	
2005/0025948	A1	2/2005	Johnson et al.	
2005/0099055	A1	5/2005	Koepke et al.	
2005/0146193	A1	7/2005	Shieh	
2006/0022506	A1	2/2006	Chan	
2006/0267258	A1	11/2006	Coffield et al.	
2006/0286359	A1	12/2006	Coffield et al.	
2007/0031667	A1	2/2007	Hook et al.	
2008/0011021	A1	1/2008	Starbuck et al.	
2008/0248710	A1	10/2008	Wittner	
2008/0258531	A1	10/2008	Lu	
2009/0020931	A1	1/2009	Coffield et al.	
2009/0021065	A1	1/2009	Brauning	
2009/0085388	A1	4/2009	Parker et al.	
2009/0239049	A1	9/2009	Hook et al.	
2010/0078975	A1	4/2010	Kang	
2011/0046715	A1	2/2011	Ugbolue et al.	
2011/0062758	A1	3/2011	Wiese	
2011/0181086	A1	7/2011	Pfeifer et al.	
2011/0282452	A1	11/2011	Koerner et al.	
2012/0007400	A1	1/2012	Behar et al.	
2012/0129416	A1	5/2012	Anand et al.	
2012/0161483	A1	6/2012	Hayashi	
2014/0084652	A1	3/2014	Norman et al.	
2014/0265493	A1	9/2014	Machael et al.	
2015/0108809	A1	4/2015	Romero	
2015/0123441	A1	5/2015	Duke	
2015/0190269	A1	7/2015	Lenoble et al.	
2015/0296989	A1	10/2015	Machael et al.	
2015/0298587	A1	10/2015	Machael et al.	
2015/0320220	A1	11/2015	Eberlein et al.	
2016/0135603	A1	5/2016	Chan et al.	

FOREIGN PATENT DOCUMENTS

CN	2256246	Y	6/1997
CN	10149202		10/2007
CN	202932442	U	5/2013
CN	203524214	U	4/2014
DE	102016010929		4/2017
GB	1224810		3/1971
JP	3974636		6/2007
JP	2008/000364		1/2008
JP	2008/237332		10/2008
JP	2009106421	A	5/2009
JP	4462227		2/2010
JP	2011136039	A	7/2011
JP	5386728	B2	1/2014
JP	2014/054578		3/2014
JP	2016152997	A	8/2016
KR	10-1575774		12/2015
KR	10-1679795		11/2016
WO	WO 1988/00523		1/1988
WO	WO 1991/01210		2/1991
WO	WO 2000/53830		9/2000
WO	WO 2003099071	A1	12/2003
WO	WO 2004/032686		4/2004
WO	WO 2004/088015		10/2004
WO	WO 2004/104315		12/2004
WO	WO 2007/133458		11/2007
WO	WO 2009/002479		12/2008
WO	WO 2010/049511		5/2010
WO	WO 2012/171911		12/2012
WO	WO 2015/108143		7/2015

OTHER PUBLICATIONS

Dolla et al., "Structural and Drug Diffusion Models of Conventional and Auxetic Drug-Eluting Stents" Research Paper dated Aug. 3, 2006, pp. 1-32.

Dolla et al., Structural and Drug Diffusion Models of Conventional and Auxetic Drug-Eluting Stents, Journal of Medical Devices, vol. 1, Mar. 2007, downloaded from the Internet on Jan. 8, 2018, pp. 47-55.

Proceedings of NanoBio 2006, Frontiers in Biomedical Devices Conference, NanoBios2006-18035, Jun. 8-9, 2006, Irvine, California, U.S.A., pp. 1-2.

Alderson, A Triumph of Lateral Thought, Chemistry & Industry, dated May 17, 1999, pp. 384-391.

Roguin et al., BeStent—The Serpentine Balloon Expandable Stent: Review of Mechanical Properties and Clinical Experience, Artif Organs, vol. 22 (3), 1998, presented in part on Jun. 29-Jul. 1, 1997, in Providence, Rhode Island, U.S.A., pp. 243-249.

Dolla, Drug Diffusion and Structural Design Criteria for Conventional and Auxetic Drug-Eluting Stents, Dissertation in Engineering and Chemistry, 2006, pp. 1-149.

Hwang, et al. 2003, downloaded from the Internet on Oct. 26, 2014, "Impact of Transport and Drug Properties on the Local Pharmacology of Drug-Eluting Stents," International Journal of Cardiovascular Interventions, 5, pp. 7-12.

Walline, K.S., 2004, "Drug Delivery Coatings for Cardiovascular Stents: Silicone Elastomer and Thrombin Responsive Hydrogel Coatings," M.S. Thesis, University of Washington.

Windecker et al., 2003, "Sirolimus Eluting Stent: A New Era in Interventional Cardiology," Current Pharmaceutical Design, 9, pp. 1077-1094.

Lu et al., 2004, "Biaxial Incremental Homeostatic Elastic Moduli of Coronary Artery: Two-Layer Model," American Journal of Physiology—Heart, vol. 287, pp. H1663-1669.

Boulanger et al., 1998, "Poisson's ratio of Orthorhombic Materials," Journal of Elasticity, vol. 50, pp. 87-89.

Clark et al., 1994, "Negative Poisson's Ratios in Angle-Ply Laminates: Theory and Experiment," Composites, vol. 25, No. 9, pp. 863-868.

Evans et al, 2004, "The Design, Matching and Manufacture of Auxetic Carbon Fiber Laminates," Journal of Composite Materials, vol. 38, No. 2, pp. 95-106.

Hine et al., 1997, Negative Poisson's Ratios in Angle-Ply Laminates, Journal of Materials Science Letters, vol. 16, No. 7, pp. 541-544.

Lakes, R.S., 1987(a), Foam Structures with a Negative Poisson's Ratio, Science, vol. 235, pp. 1038-1040, dated Feb. 27, 1987.

Lakes, R.S. et al., 1993, Indentability of Conventional and Negative Poisson's Ratio Foams, Journal of Composite Materials, vol. 27, pp. 1193-1202.

Warren, T.L., 1990, "Negative Poisson's Ratio in a Transversely Isotropic Foam Structure," Journal of Applied Physics, vol. 67, No. 12, pp. 7591-7594, dated Jun. 15, 1990.

Baughman et al., "Negative Poisson's Ratios as a Common Feature of Cubic Metals," Letters to Nature, vol. 392, MacMillan Publishers Ltd., 1998; dated Mar. 26, 1998, pp. 362-365.

Choi et al., "Fracture Toughness of Renetrant Foam Materials with a Negative Poisson's Ratio: Experiment and Analysis," Int. J. Fracture, vol. 80, 1996, pp. 73-83.

Amir Yeganeh-Haeri et al., "Elasticity of #-Christobalite: A Silicon Dioxide with a Negative Poisson's Ratio," Science, vol. 257, No. 5070, pp. 650-652, dated Jul. 31, 1992.

Smardzewski et al., "Auxetic Spring Elements for Elastically Supporting a Sitting or Lying," Article, WULS-SGGW, Forest and Wood Technology 73, 2011, 9 pages.

Smardzewski, "Auxetic Springs for Seating," Journal, May 6, 2013, 8 pages, Poznan, Poland.

Smardzewski et al., "Design of Small Auxetic Springs for Furniture," 2 pgs.

* cited by examiner

Primary Examiner — Kevin K Rudzinski

Assistant Examiner — Paul D Bohannon

(74) *Attorney, Agent, or Firm* — Brinks Gilson & Lione

(57)

CLAIM

We claim the ornamental design for a chair with upholstered back, as shown and described.

DESCRIPTION

FIG. 1 is a top front perspective view of a chair with upholstered back;

FIG. 2 is a top plan view thereof;

FIG. 3 is a bottom plan view thereof;

FIG. 4 is a rear elevation view thereof;

FIG. 5 is a front elevation view thereof;

FIG. 6 is a right side elevation view thereof; and,

FIG. 7 is a left side elevation view thereof.

The broken lines shown in the drawings are for the purpose of illustrating portions of the article that form no part of the claimed design.

1 Claim, 7 Drawing Sheets

FIG. 1

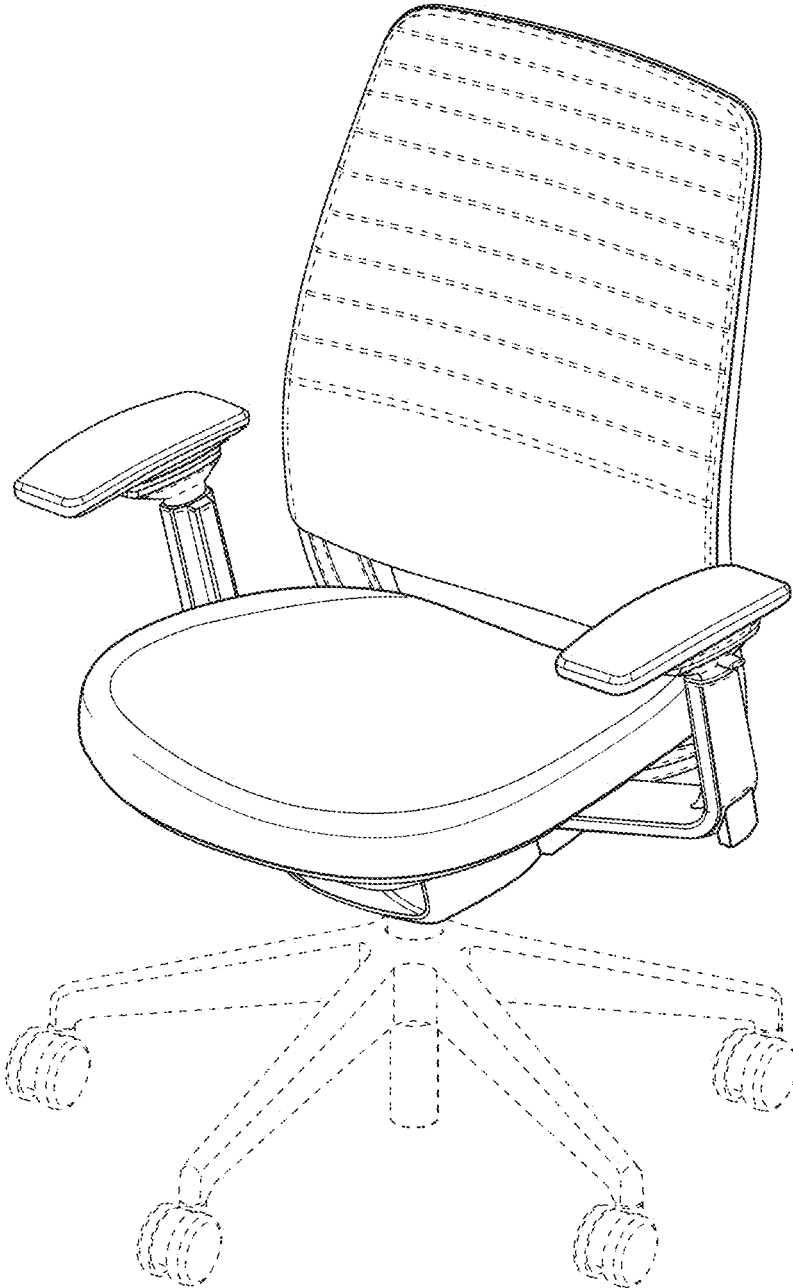

FIG. 2

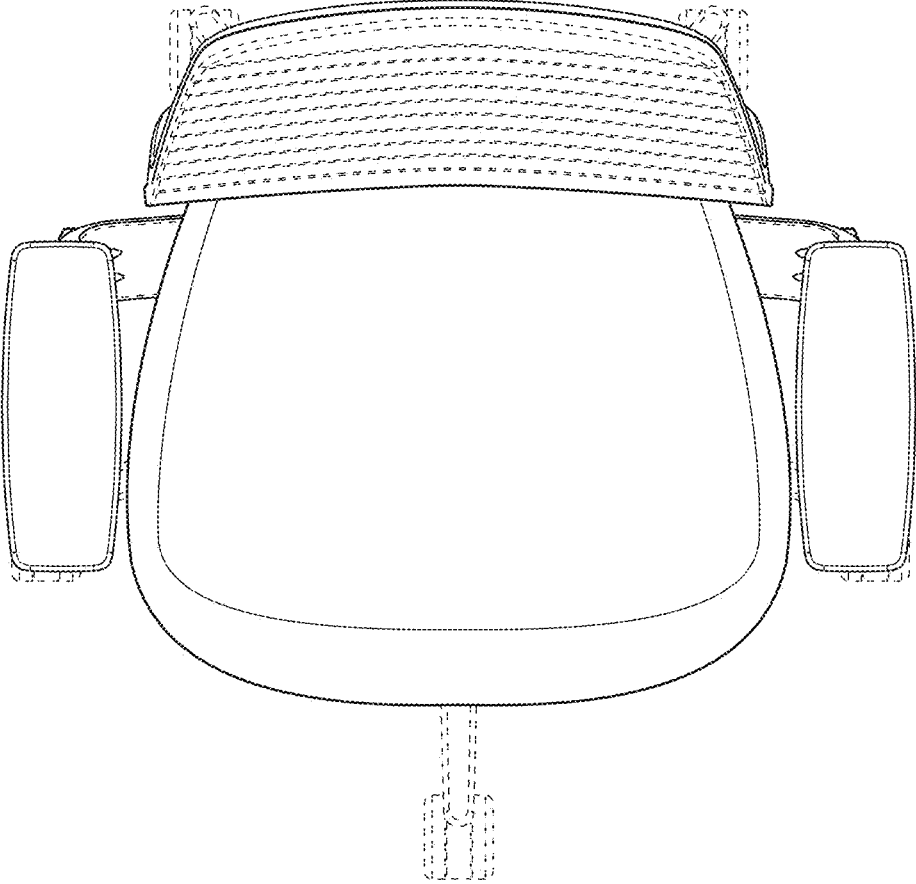

FIG. 3

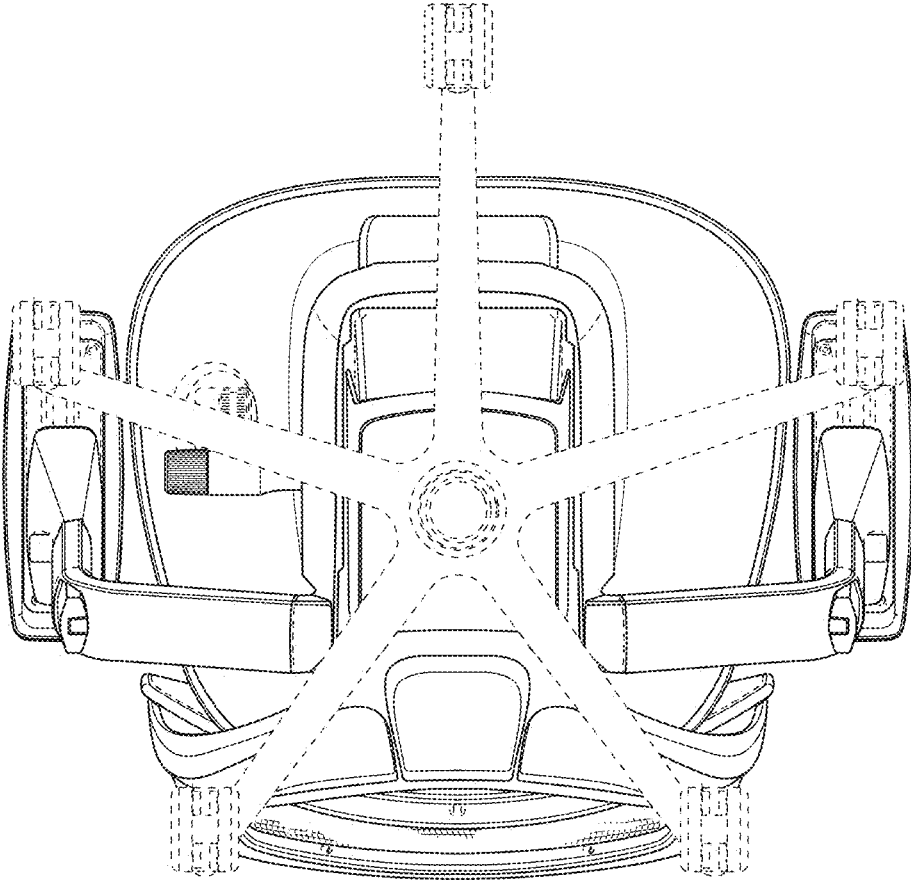

FIG. 4

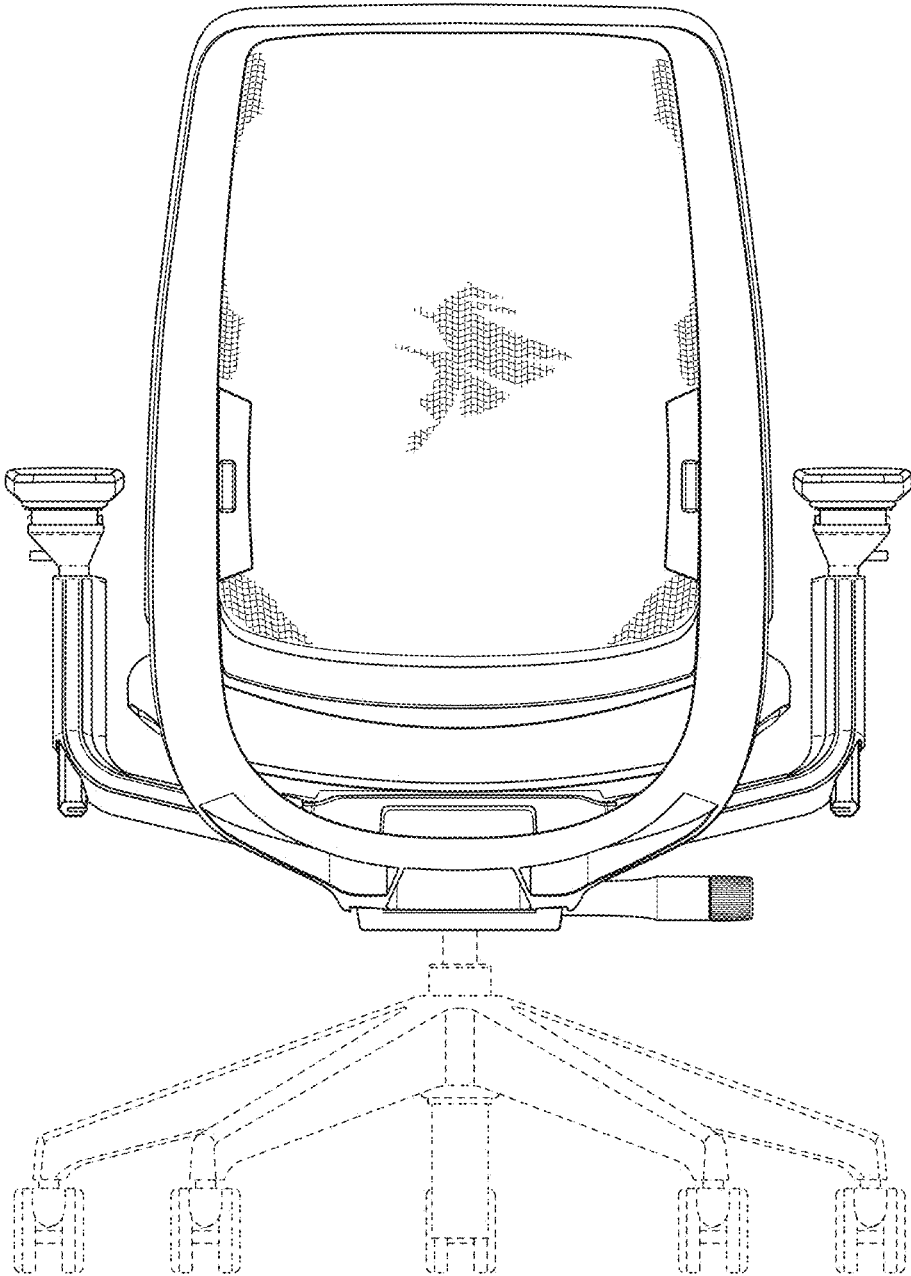

FIG. 5

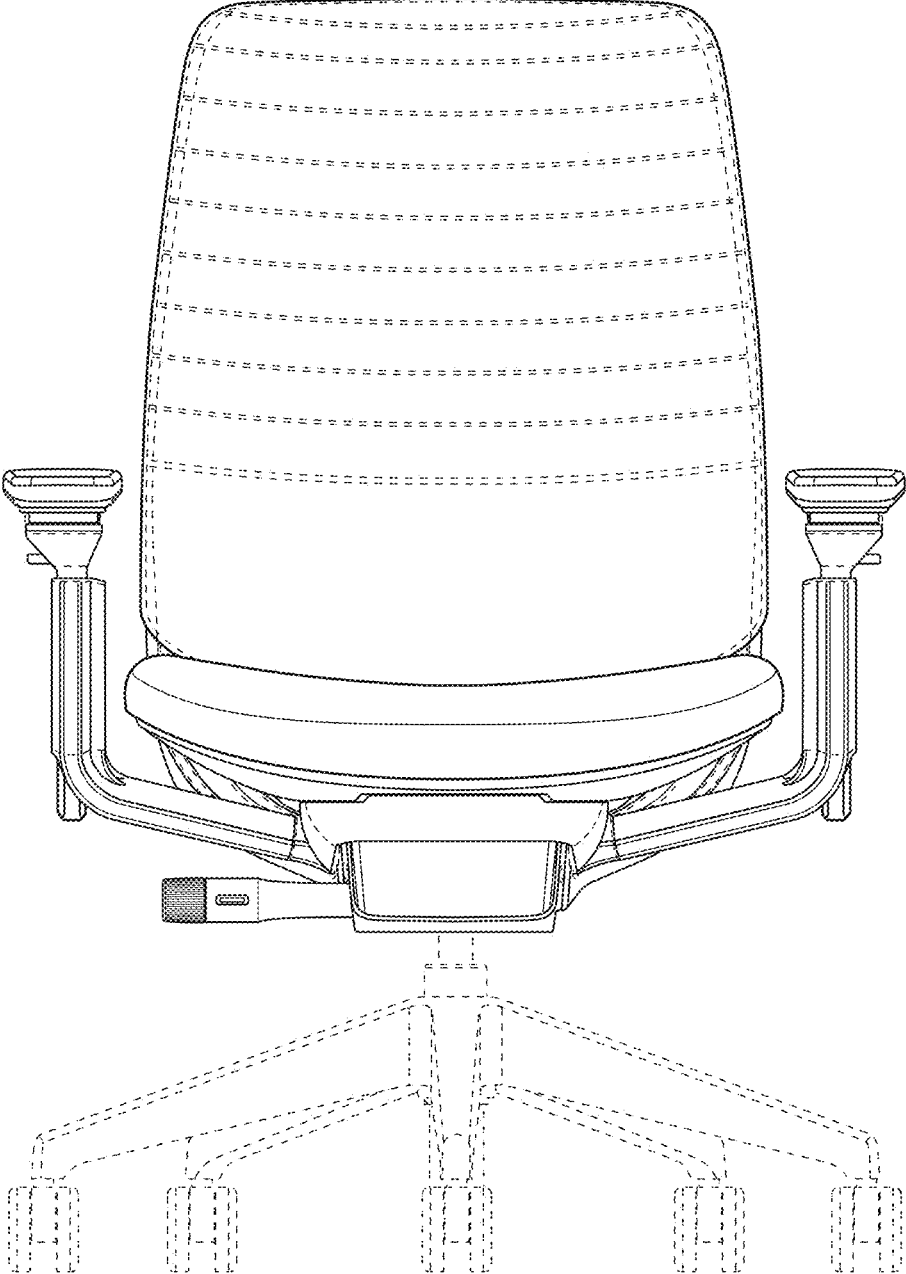

FIG. 6

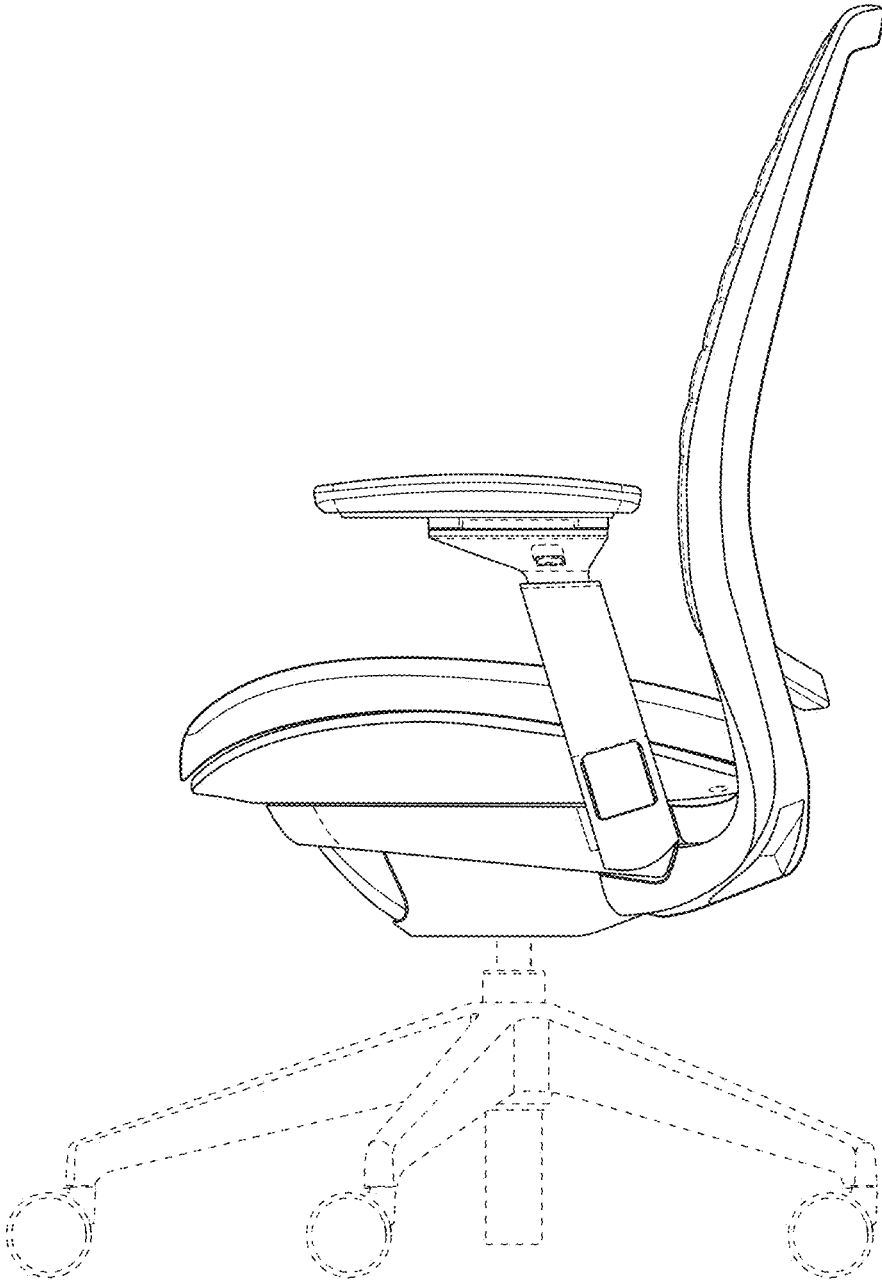

FIG. 7

