



(11) **EP 2 102 396 B1**

(12) **EUROPEAN PATENT SPECIFICATION**

(45) Date of publication and mention of the grant of the patent:
04.05.2011 Bulletin 2011/18

(21) Application number: **08705940.8**

(22) Date of filing: **16.01.2008**

(51) Int Cl.:
D01F 6/30 (2006.01) B32B 27/32 (2006.01)

(86) International application number:
PCT/US2008/051142

(87) International publication number:
WO 2008/089220 (24.07.2008 Gazette 2008/30)

(54) **COLORFAST FABRICS AND GARMENTS OF OLEFIN BLOCK COMPOSITIONS**

FARBFESTE FASERN UND KLEIDUNGSSTÜCKE AUS OLEFINBLOCKZUSAMMENSETZUNGEN
TISSUS ET VÊTEMENTS À COULEURS SOLIDES OBTENUS À PARTIR DE COMPOSITIONS DE POLYMÈRES OLÉFINIQUES SÉQUENCÉS

(84) Designated Contracting States:
AT BE BG CH CY CZ DE DK EE ES FI FR GB GR HR HU IE IS IT LI LT LU LV MC MT NL NO PL PT RO SE SI SK TR

(30) Priority: **16.01.2007 US 885202 P**

(43) Date of publication of application:
23.09.2009 Bulletin 2009/39

(73) Proprietor: **Dow Global Technologies LLC**
Midland, MI 48647 (US)

(72) Inventors:
• **D'OTTAVIANO, Fabio**
E-43850 Cambrils (ES)
• **WANG, Jerry Chien Ting**
Mei-Chuan East Road
Taichung (TW)
• **NEEL, Rhonda N.**
E-08860 Castelldefels (ES)
• **CHIU, Debbie Y.**
Pearland, TX 77584 (US)

- **ZHANG, Traci Li Zhi**
Shanghai (CN)
- **LAI, Shih-Yaw**
Marlboro, NJ 07746 (US)
- **LAMIA, Alberto Lora**
E-43007 Tarragona (ES)
- **CHEN, Hongyu**
Lake Jackson, TX 77566 (US)

(74) Representative: **Hatzmann, Martin et al**
Vereenigde
Johan de Wittlaan 7
2517 JR Den Haag (NL)

(56) References cited:
WO-A-2006/102149

Remarks:

The file contains technical information submitted after the application was filed and not included in this specification

EP 2 102 396 B1

Note: Within nine months of the publication of the mention of the grant of the European patent in the European Patent Bulletin, any person may give notice to the European Patent Office of opposition to that patent, in accordance with the Implementing Regulations. Notice of opposition shall not be deemed to have been filed until the opposition fee has been paid. (Art. 99(1) European Patent Convention).

Description

FIELD OF THE INVENTION

5 **[0001]** This invention relates to dyed fabrics that are colorfast.

BACKGROUND AND SUMMARY OF THE INVENTION

10 **[0002]** Many different materials have been used in making dyed fabrics for use in, for example, garments. It is often desirable that such fabrics have a combination of properties including one or more of the following: dimensional stability, heat-set properties, capability to be made stretchable in one or both dimensions, chemical, heat, and abrasion resistant, tenacity, etc. In addition, it is also often important that such dyed fabrics be able to hold color, e.g., dye, longer and darker when subjected to laundering without significantly degrading one or more of the aforementioned properties. Further, increased throughput with reduced defects, e.g., fiber breakage, is sometimes desirable if the dyed fabric is, for example, a knitted fabric. WO 2006/102149 describes fibers made from ethylene α -olefin block copolymers and fabrics made from these copolymers. The elastic fibers are soft and yielding to body movement. The fibers do not require cumbersome processing steps and provide soft, comfortable fabrics which are not tacky.

15 **[0003]** Improved fabrics have now been discovered which often have a balanced combination of desirable properties including being able to be colored darker and hold color, i.e., colorfast, with laundering. These compositions may also allow for improved processability in some applications. The fabric of the present invention is typically a knit or woven fabric comprising elastic fibers. Such knit fabrics include, for example, polyesters like microfiber polyesters. The elastic fibers often comprise the reaction product of at least one ethylene block polymer and at least one crosslinking agent. The fibers are characterized by an amount of crosslinking such that the fabric has the desired properties. A dyed fabric according to the invention comprises one or more elastic fibers wherein the elastic fibers comprise the reaction product of at least one ethylene olefin block copolymer and at least one chemical or radiation crosslinking agent wherein said fabric is in the form of (1) a woven fabric which is characterized by a stretch of at least 10 percent measured according to ASTM D3107 or (2) a knit fabric which is characterized by a stretch of at least 30 percent measured according to ASTM D2594, and wherein said fabric is characterized by a color change of greater than or equal to 3.0 according to AATCC evaluation after a first wash by AATCC61-2003-2A. The ethylene block polymer is usually

30 (A) an ethylene/ α -olefin interpolymer, wherein the ethylene/ α -olefin interpolymer has one or more of the following characteristics:

35 (1) an average block index greater than zero and up to 1.0 and a molecular weight distribution, M_w/M_n, greater than 1.3; or

(2) at least one molecular fraction which elutes between 40°C and 130°C when fractionated using TREF, characterized in that the fraction has a block index of at least 0.5 and up to 1; or

40 (3) an M_w/M_n from 1.7 to 3.5, at least one melting point, T_m, in degrees Celsius, and a density, d, in g/cm³ grams/cubic centimeter, wherein the numerical values of T_m and d correspond to the relationship:

$$45 \quad T_{m} > -2002.9 + 4538.5(d) - 2422.2(d)^2;$$

or

50 (4) an M_w/M_n from 1.7 to 3.5, and is characterized by a heat of fusion, ΔH in J/g, and a delta quantity, ΔT , in degrees Celsius, defined as the temperature difference between the tallest DSC peak and the tallest CRYSTAF peak, wherein the numerical values of ΔT and ΔH have the following relationships;

$$55 \quad \Delta T > -0.1299(\Delta H) + 62.81$$

for ΔH greater than zero and up to 130 J/g,

$$\Delta T \geq 48^{\circ}\text{C}$$

5 for ΔH greater than 130 J/g .
 wherein the CRYSTAF peak is determined using at least 5 percent of the cumulative polymer, and if less than 5 percent of the polymer has an identifiable CRYSTAF peak, then the CRYSTAF temperature is 30°C; or

10 (5) an elastic recovery, R_e , in percent at 300 percent strain and 1 cycle measured with a compression-molded film of the ethylene/ α -olefin interpolymer, and has a density, d , in grams/cubic centimeter, wherein the numerical values of R_e and d satisfy the following relationship when ethylene/ α -olefin interpolymer is substantially free of a cross-linked phase:

$$15 \quad R_e > 1481 - 1629(d);$$

or

20 (6) a molecular fraction which elutes between 40°C and 130°C when fractionated using TREF, characterized in that the fraction has a molar comonomer content of at least 5 percent higher than that of a comparable random ethylene interpolymer fraction eluting between the same temperatures, wherein said comparable random ethylene interpolymer has the same comonomer(s) and has a melt index, density, and molar comonomer content (based on the whole polymer) within 10 percent of that of the ethylene/ α -olefin interpolymer; or

25 (7) a storage modulus at 25°C, $G'(25^{\circ}\text{C})$, and a storage modulus at 100 °C, $G'(100^{\circ}\text{C})$, wherein the ratio of $G'(25^{\circ}\text{C})$ to $G'(100^{\circ}\text{C})$ is in the range of 1:1 to 9:1.

30 **[0004]** The ethylene/ α -olefin interpolymer characteristics (1) through (7) above are given with respect to the ethylene/ α -olefin interpolymer before any significant crosslinking, i.e., before crosslinking. The ethylene/ α -olefin interpolymers useful in the present invention are usually crosslinked to a degree to obtain the desired properties. By using characteristics (1) through (7) as measured before crosslinking is not meant to suggest that the interpolymer is not required to be crosslinked - only that the characteristic is measured with respect to the interpolymer without significant crosslinking. Crosslinking may or may not change each of these properties depending upon the specific polymer and degree of crosslinking. The dyed fabrics of the present invention may often be characterized by a color change of greater than or
 35 equal to 3.0 according to AATCC evaluation after a first wash by AATCC61-2003-2A. The dyed fabrics of the present invention may often be characterized by a color strength after dyeing of greater than or equal to 600 as measured with a spectrum photometer.

40 BRIEF DESCRIPTION OF THE DRAWINGS

[0005] Figure 1 shows the melting point/density relationship for the inventive polymers (represented by diamonds) as compared to traditional random copolymers (represented by circles) and Ziegler-Natta copolymers (represented by triangles).

45 **[0006]** Figure 2 shows plots of delta DSC-CRYSTAF as a function of DSC Melt Enthalpy for various polymers. The diamonds represent random ethylene/octene copolymers; the squares represent polymer examples 1-4; the triangles represent polymer examples 5-9; and the circles represent polymer examples 10-19. The "X" symbols represent polymer examples A*-F*.

50 **[0007]** Figure 3 shows the effect of density on elastic recovery for unoriented films made from inventive interpolymers (represented by the squares and circles) and traditional copolymers (represented by the triangles which are various AFFINITY™ polymers (available from The Dow Chemical Company)). The squares represent inventive ethylene/butene copolymers; and the circles represent inventive ethylene/octene copolymers.

[0008] Figure 4 is a plot of octene content of TREF fractionated ethylene/ 1-octene copolymer fractions versus TREF elution temperature of the fraction for the polymer of Example 5 (represented by the circles) and comparative polymers E and F (represented by the "X" symbols). The diamonds represent traditional random ethylene/octene copolymers.

55 **[0009]** Figure 5 is a plot of octene content of TREF fractionated ethylene/1-octene copolymer fractions versus TREF elution temperature of the fraction for the polymer of Example 5 (curve 1) and for comparative F (curve 2). The squares represent Example F*; and the triangles represent Example 5.

[0010] Figure 6 is a graph of the log of storage modulus as a function of temperature for comparative ethylene/1-octene copolymer (curve 2) and propylene/ethylene-copolymer (curve 3) and for two ethylene/1-octene block copolymers of the invention made with differing quantities of chain shuttling agent (curves 1).

[0011] Figure 7 shows a plot of TMA (1mm) versus flex modulus for some inventive polymers (represented by the diamonds), as compared to some known polymers. The triangles represent various Dow VERSIFY™ polymers (available from The Dow Chemical Company); the circles represent various random ethylene/styrene copolymers; and the squares represent various Dow AFFINITY™ polymers (available from The Dow Chemical Company).

[0012] Figure 8 shows photos of a lab dyeing machine.

[0013] Figure 9 shows a dyeing and reduction wash process.

DETAILED DESCRIPTION OF THE INVENTION

General Definitions

[0014] "Fiber" means a material in which the length to diameter ratio is greater than 10. Fiber is typically classified according to its diameter. Filament fiber is generally defined as having an individual fiber diameter greater than 15 denier, usually greater than 30 denier per filament. Fine denier fiber generally refers to a fiber having a diameter less than 15 denier per filament. Microdenier fiber is generally defined as fiber having a diameter less than 100 μm (microns) denier per filament.

[0015] "Filament fiber" or "monofilament fiber" means a continuous strand of material of indefinite (i.e., not predetermined) length, as opposed to a "staple fiber" which is a discontinuous strand of material of definite length (i.e., a strand which has been cut or otherwise divided into segments of a predetermined length).

[0016] "Elastic" means that a fiber will recover at least 50 percent of its stretched length after the first pull and after the fourth to 100% strain (doubled the length). Elasticity can also be described by the "permanent set" of the fiber.

Permanent set is the converse of elasticity. A fiber is stretched to a certain point and subsequently released to the original position before stretch, and then stretched again. The point at which the fiber begins to pull a load is designated as the percent permanent set. "Elastic materials" are also referred to in the art as "elastomers" and "elastomeric". Elastic material (sometimes referred to as an elastic article) includes the copolymer itself as well as, but not limited to, the copolymer in the form of a fiber, film, strip, tape, ribbon sheet, coating, molding and the like. The preferred elastic material is fiber. The elastic material can be either cured or uncured, radiated or un-radiated, and/or crosslinked or uncrosslinked.

[0017] "Nonelastic material" means a material, e.g., a fiber, that is not elastic as defined above.

[0018] "Homofil fiber" means a fiber that has a single polymer region or domain, and that does not have any other distinct polymer regions (as do bicomponent fibers).

[0019] "Bicomponent fiber" means a fiber that has two or more distinct polymer regions or domains. Bicomponent fibers are also known as conjugated or multicomponent fibers. The polymers are usually different from each other although two or more components may comprise the same polymer. The polymers are arranged in substantially distinct zones across the cross-section of the bicomponent fiber, and usually extend continuously along the length of the bicomponent fiber. The configuration of a bicomponent fiber can be, for example, a sheath/core arrangement (in which one polymer is surrounded by another), a side by side arrangement, a pic arrangement or an "islands-in-the sea" arrangement. Bicomponent fibers are further described in U.S. Patents No. 6,225,243, 6,140,442, 5,382,400, 5,336,552 and 5,108,820.

[0020] "Meltblown fibers" are fibers formed by extruding a molten thermoplastic polymer composition through a plurality of fine, usually circular, die capillaries as molten threads or filaments into converging high velocity gas streams (e.g. air) which function to attenuate the threads or filaments to reduced diameters. The filaments or threads are carried by the high velocity gas streams and deposited on a collecting surface to form a web of randomly dispersed fibers with average diameters generally smaller than 10 μm (microns).

[0021] "Meltspun fibers" are fibers formed by melting at least one polymer and then drawing the fiber in the melt to a diameter (or other cross-section shape) less than the diameter (or other cross-section shape) of the die.

[0022] "Spunbond fibers" are fibers formed by extruding a molten thermoplastic polymer composition as filaments through a plurality of fine, usually circular, die capillaries of a spinneret. The diameter of the extruded filaments is rapidly reduced, and then the filaments are deposited onto a collecting surface to form a web of randomly dispersed fibers with average diameters generally between 7 and 30 μm (microns).

[0023] "Nonwoven" means a web or fabric having a structure of individual fibers or threads which are randomly interlaid, but not in an identifiable manner as is the case of a knitted fabric. The elastic fiber in accordance with embodiments of the invention can be employed to prepare nonwoven structures as well as composite structures of elastic nonwoven fabric in combination with nonelastic materials.

[0024] "Yarn" means a continuous length of twisted or otherwise entangled filaments which can be used in the manufacture of woven or knitted fabrics and other articles. Yarn can be covered or uncovered. Covered yarn is yarn at least partially wrapped within an outer covering of another fiber or material, typically a natural fiber such as cotton or wool.

[0025] "Polymer" means a polymeric compound prepared by polymerizing monomers, whether of the same or a different type. The generic term "polymer" embraces the terms "homopolymer," "copolymer," "terpolymer" as well as "interpolymer."

[0026] "Interpolymer" means a polymer prepared by the polymerization of at least two different types of monomers. The generic term "interpolymer" includes the term "copolymer" (which is usually employed to refer to a polymer prepared from two different monomers) as well as the term "terpolymer" (which is usually employed to refer to a polymer prepared from three different types of monomers). It also encompasses polymers made by polymerizing four or more types of monomers.

[0027] The term "ethylene/ α -olefin interpolymer" generally refers to polymers comprising ethylene and an α -olefin having 3 or more carbon atoms. Preferably, ethylene comprises the majority mole fraction of the whole polymer, i.e., ethylene comprises at least 50 mole percent of the whole polymer. More preferably ethylene comprises at least 60 mole percent, at least 70 mole percent, or at least 80 mole percent, with the substantial remainder of the whole polymer comprising at least one other comonomer that is preferably an α -olefin having 3 or more carbon atoms. For many ethylene/octene copolymers, the preferred composition comprises an ethylene content greater than 80 mole percent of the whole polymer and an octene content of from 10 to 15, preferably from 15 to 20 mole percent of the whole polymer. In some embodiments, the ethylene/ α -olefin interpolymers do not include those produced in low yields or in a minor amount or as a by-product of a chemical process. While the ethylene/ α -olefin interpolymers can be blended with one or more polymers, the as-produced ethylene/ α -olefin interpolymers are substantially pure and often comprise a major component of the reaction product of a polymerization process.

[0028] The ethylene/ α -olefin interpolymers comprise ethylene and one or more copolymerizable α -olefin comonomers in polymerized form, characterized by multiple blocks or segments of two or more polymerized monomer units differing in chemical or physical properties. That is, the ethylene/ α -olefin interpolymers are block interpolymers, preferably multi-block interpolymers or copolymers. The terms "interpolymer" and "copolymer" are used interchangeably herein. In some embodiments, the multi-block copolymer can be represented by the following formula:



where n is at least 1, preferably an integer greater than 1, such as 2,3,4, 5, 10, 15,20, 30,40, 50, 60, 70, 80, 90, 100, or higher, "A" represents a hard block or segment and "B" represents a soft block or segment. Preferably, As and Bs are linked in a substantially linear fashion, as opposed to a substantially branched or substantially star-shaped fashion. In other embodiments, A blocks and B blocks are randomly distributed along the polymer chain. In other words, the block copolymers usually do not have a structure as follows.



[0029] In still other embodiments, the block copolymers do not usually have a third type of block, which comprises different comonomer(s). In yet other embodiments, each of block A and block B has monomers or comonomers substantially randomly distributed within the block. In other words, neither block A nor block B comprises two or more sub-segments (or sub-blocks) of distinct composition, such as a tip segment, which has a substantially different composition than the rest of the block.

[0030] The multi-block polymers typically comprise various amounts of "hard" and "soft" segments. "Hard" segments refer to blocks of polymerized units in which ethylene is present in an amount greater than 95 weight percent, and preferably greater than 98 weight percent based on the weight of the polymer. In other words, the comonomer content (content of monomers other than ethylene) in the hard segments is less than 5 weight percent, and preferably less than 2 weight percent based on the weight of the polymer. In some embodiments, the hard segments comprises all or substantially all ethylene. "Soft" segments, on the other hand, refer to blocks of polymerized units in which the comonomer content (content of monomers other than ethylene) is greater than 5 weight percent, preferably greater than 8 weight percent, greater than 10 weight percent, or greater than 15 weight percent based on the weight of the polymer. In some embodiments, the comonomer content in the soft segments can be greater than 20 weight percent, greater than 25 weight percent, greater than 30 weight percent, greater than 35 weight percent, greater than 40 weight percent, greater than 45 weight percent, greater than 50 weight percent, or greater than 60 weight percent.

[0031] The soft segments can often be present in a block interpolymer from 1 weight percent to 99 weight percent of the total weight of the block interpolymer, preferably from 5 weight percent to 95 weight percent, from 10 weight percent to 90 weight percent, from 15 weight percent to 85 weight percent, from 20 weight percent to 80 weight percent, from 25 weight percent to 75 weight percent, from 30 weight percent to 70 weight percent, from 35 weight percent to 65 weight

percent, from 40 weight percent to 60 weight percent, or from 45 weight percent to 55 weight percent of the total weight of the block interpolmer. Conversely, the hard segments can be present in similar ranges. The soft segment weight percentage and the hard segment weight percentage can be calculated based on data obtained from DSC or NMR. Such methods and calculations are disclosed in a concurrently filed U.S. Patent Application Serial No. 11/376.835.

[0032] The term "crystalline" if employed refers to a polymer that possesses a first order transition or crystalline melting point (T_m) as determined by differential scanning calorimetry (DSC) or equivalent technique. The term may be used interchangeably with the term "semicrystalline". The term "amorphous" refers to a polymer lacking a crystalline melting point as determined by differential scanning calorimetry (DSC) or equivalent technique.

[0033] The term "multi-block copolymer" or "segmented copolymer" refers to a polymer comprising two or more chemically distinct regions or segments (referred to as "blocks") preferably joined in a linear manner, that is, a polymer comprising chemically differentiated units which are joined end-to-end with respect to polymerized ethylenic functionality, rather than in pendent or grafted fashion. In a preferred embodiment, the blocks differ in the amount or type of comonomer incorporated therein, the density, the amount of crystallinity, the crystallite size attributable to a polymer of such composition, the type or degree of tacticity (isotactic or syndiotactic), regio-regularity or regio-irregularity, the amount of branching, including long chain branching or hyper-branching, the homogeneity, or any other chemical or physical property. The multi-block copolymers are characterized by unique distributions of both polydispersity index (PDI or M_w/M_n), block length distribution, and/or block number distribution due to the unique process making of the copolymers. More specifically, when produced in a continuous process, the polymers desirably possess PDI from 1.7 to 2.9, preferably from 1.8 to 2.5, more preferably from 1.8 to 2.2, and most preferably from 1.8 to 2.1. When produced in a batch or semi-batch process, the polymers possess PDI from 1.0 to 2.9, preferably from 1.3 to 2.5, more preferably from 1.4 to 2.0, and most preferably from 1.4 to 1.8.

[0034] In the following description, all numbers disclosed herein are approximate values, regardless whether the word "about" or "approximate" is used in connection therewith. They may vary by 1 percent, 2 percent, 5 percent, or, sometimes, 10 to 20 percent. Whenever a numerical range with a lower limit, R^L and an upper limit, R^U , is disclosed, any number falling within the range is specifically disclosed. In particular, the following numbers within the range are specifically disclosed: $R=R^L+k*(R^U-R^L)$, wherein k is a variable ranging from 1 percent to 100 percent with a 1 percent increment, i.e., k is 1 percent, 2 percent, 3 percent, 4 percent, 5 percent, ..., 50 percent, 51 percent, 52 percent, ..., 95 percent, 96 percent, 97 percent, 98 percent, 99 percent, or 100 percent. Moreover, any numerical range defined by two R numbers as defined in the above is also specifically disclosed.

Ethylene/ α -Olefin Interpolymers

[0035] The olefin block polymers, e.g. ethylene/ α -olefin interpolymers, used in embodiments of the invention (also referred to as "inventive interpolmer" or "inventive polymer") comprise ethylene and one or more copolymerizable α -olefin comonomers in polymerized form, characterized by multiple blocks or segments of two or more polymerized monomer units differing in chemical or physical properties (block interpolmer), preferably a multi-block copolymer. The ethylene/ α -olefin interpolymers are characterized by one or more of the aspects described as follows.

[0036] In one aspect, the ethylene/ α -olefin interpolymers used in embodiments of the invention have a M_w/M_n from 1.7 to 3.5 and at least one melting point, T_m , in degrees Celsius and density, d , in grams/cubic centimeter, wherein the numerical values of the variables correspond to the relationship:

$$T_m > -2002.9 + 4538.5(d) - 2422.2(d)^2, \text{ and preferably}$$

$$T_m \geq -6288.1 + 13141(d) - 6720.3(d)^2, \text{ and more preferably}$$

$$T_m \geq 858.91 - 1825.3(d) + 1112.8(d)^a.$$

[0037] Such melting point/density relationship is illustrated in Figure 1. Unlike the traditional random copolymers of ethylene/ α -olefins whose melting points decrease with decreasing densities, the inventive interpolymers (represented by diamonds) exhibit melting points substantially independent of the density, particularly when density is between 0.87 g/cm³ (g/cc) to 0.95 g/cm³ (g/cc). For example, the melting point of such polymers are in the range of 110 °C to 130 °C when density ranges from 0.875 g/cm³ (g/cc) to 0.945 g/cm³ (g/cc). In some embodiments, the melting point of such polymers are in the range of 115 °C to 125 °C when density ranges from 0.875 g/cm³ (g/cc) to 0.945 g/cm³ (g/cc).

[0038] In another aspect, the ethylene/ α -olefin interpolymers comprise, in polymerized form, ethylene and one or more α -olefins and are characterized by a ΔT , in degree Celsius, defined as the temperature for the tallest Differential Scanning Calorimetry ("DSC") peak minus the temperature for the tallest Crystallization Analysis Fractionation ("CRYSTAF") peak and a heat of fusion in J/g, ΔH , and ΔT and ΔH satisfy the following relationships:

EP 2 102 396 B1

$\Delta T > -0.1299(\Delta H) + 62.81$, and preferably

$\Delta T \geq -0.1299(\Delta H) + 64.38$, and more preferably

5 $\Delta T \geq -0.1299(\Delta H) + 65.95$,

for AH up to 130 J/g. Moreover, ΔT is equal to or greater than 48 °C for ΔH greater than 130 J/g. The CRYSTAF peak is determined using at least 5 percent of the cumulative polymer (that is, the peak must represent at least 5 percent of the cumulative polymer), and if less than 5 percent of the polymer has an identifiable CRYSTAF peak, then the CRYSTAF temperature is 30°C, and AH is the numerical value of the heat of fusion in J/g. More preferably, the highest CRYSTAF peak contains at least 10 percent of the cumulative polymer. Figure 2 shows plotted data for inventive polymers as well as comparative examples. Integrated peak areas and peak temperatures are calculated by the computerized drawing program supplied by the instrument maker. The diagonal line shown for the random ethylene octene comparative polymers corresponds to the equation $\Delta T = -0.1299(\Delta H) + 62.81$.

15 **[0039]** In yet another aspect, the ethylene/ α -olefin interpolymer have a molecular fraction which elutes between 40°C and 130°C when fractionated using Temperature Rising Elution Fractionation ("TREF"), characterized in that said fraction has a molar comonomer content higher, preferably at least 5 percent higher, more preferably at least 10 percent higher, than that of a comparable random ethylene interpolymer fraction eluting between the same temperatures, wherein the comparable random ethylene interpolymer contains the same comonomer(s), and has a melt index, density, and molar comonomer content (based on the whole polymer) within 10 percent of that of the block interpolymer. Preferably, the Mw/N1n of the comparable interpolymer is also within 10 percent of that of the block interpolymer and/or the comparable interpolymer has a total comonomer content within 10 weight percent of that of the block interpolymer.

20 **[0040]** In still another aspect, the ethylene/ α -olefin interpolymers are characterized by an elastic recovery, Re, in percent at 300 percent strain and 1 cycle measured on a compression-molded film of an ethylene/ α -olefin interpolymers, and has a density, d, in grams/cubic centimeter, wherein the numerical values of Re and d satisfy the following relationship when ethylene/ α -olefin interpolymer is substantially free of a cross-linked phase:

$$\mathbf{Re > 1481 - 1629(d);}$$

30 and preferably

$$\mathbf{Re \geq 1491 - 1629(d);}$$

35 and more preferably

$$\mathbf{Re \geq 1501 - 1629(d);}$$

40 and even more preferably

$$\mathbf{Re \geq 1511 - 1629(d).}$$

45 **[0041]** Figure 3 shows the effect of density on elastic recovery for unoriented films made from certain inventive interpolymers and traditional random copolymers, For the same density, the inventive interpolymers have substantially higher elastic recoveries,

50 **[0042]** The ethylene/ α -olefin interpolymers for use in the present invention may have a tensile strength above 10 MPa, preferably a tensile strength ≥ 11 MPa, more preferably a tensile strength ≥ 13 MPa and/or an elongation at break of at least 600 percent, more preferably at least 700 percent, highly preferably at least 800 percent, and most highly preferably at least 900 percent at a crosshead separation rate of 11 cm/minute.

55 **[0043]** In another aspect, the ethylene/ α -olefin interpolymers may have (1) a storage modulus ratio, $G'(25^\circ\text{C})/G'(100^\circ\text{C})$, of from 1 to 50, preferably from 1 to 20, more preferably from 1 to 10; and/or (2) a 70°C compression set of less than 80 percent, preferably less than 70 percent, especially less than 60 percent, less than 50 percent, or less than 40 percent, down to a compression set of 0 percent.

[0044] In particular, the ethylene/ α -olefin interpolymers can have a 70°C compression set of less than 80 percent, less than 70 percent, less than 60 percent, or less than 50 percent. Preferably, the 70°C compression set of the interpolymers is less than 40 percent, less than 30 percent, less than 20 percent, and may go down to about 0 percent.

[0045] The ethylene/ α -olefin interpolymers for use in the present invention can have a heat of fusion of less than 85 J/g and/or a pellet blocking strength of equal to or less than 100 pounds/foot² (4800 Pa), preferably equal to or less than 50 lbs/ft² (2400 Pa), especially equal to or less than 5 lbs/ft² (240 Pa), and as low as 0 lbs/ft² (0 Pa).

[0046] Further, the ethylene/ α -olefin interpolymers may comprise, in polymerized form, at least 50 mole percent ethylene and have a 70°C compression set of less than 80 percent, preferably less than 70 percent or less than 60 percent, most preferably less than 40 to 50 percent and down to close to zero percent.

[0047] The multi-block copolymer for use in the present invention can possess a PDI fitting a Schultz-Flory distribution rather than a Poisson distribution. The copolymers can further be characterized as having both a polydisperse block distributions and a polydisperse distribution of block sizes and possessing a most probable distribution of block lengths. Preferred multi-block copolymers are those containing 4 or more blocks or segments including terminal blocks. More preferably, the copolymers include at least 5, 10 or 20 blocks or segments including terminal blocks.

[0048] Comonomer content may be measured using any suitable technique, with techniques based on nuclear magnetic resonance ("NMR") spectroscopy preferred. Moreover, for polymers or blends of polymers having relatively broad TREF curves, the polymer desirably is first fractionated using TREF into fractions each having an eluted temperature range of 10°C or less. That is, each eluted fraction has a collection temperature window of 10°C or less. Using this technique, said block interpolymers have at least one such fraction having a higher molar comonomers content than a corresponding fraction of the comparable interpolymer.

[0049] In another aspect, the inventive polymer is an olefin interpolymer, preferably comprising ethylene and one or more copolymerizable comonomers in polymerized form, characterized by multiple blocks (i.e., at least two blocks) or segments of two or more polymerized monomer units differing in chemical or physical properties (blocked interpolymer), most preferably a multi-block copolymer, said block interpolymer having a peak (but not just a molecular fraction) which elutes between 40°C and 130°C (but without collecting and/or isolating individual fractions), characterized in that said peak, has a comonomer content estimated by infra-red spectroscopy when expanded using a full width/half maximum (FWHM) area calculation, has an average molar comonomer content higher, preferably at least 5 percent higher, more preferably at least 10 percent higher, than that of a comparable random ethylene interpolymer peak at the same elution temperature and expanded using a full width/half maximum (FWHM) area calculation, wherein said comparable random ethylene interpolymer has the same comonomer(s) and has a melt index, density, and molar comonomer content (based on the whole polymer) within 10 percent of that of the blocked interpolymer. Preferably, the Mw/Mn of the comparable interpolymer is also within 10 percent of that of the blocked interpolymer and/or the comparable interpolymer has a total comonomer content within 10 weight percent of that of the blocked interpolymer. The full width/half maximum (FWHM) calculation is based on the ratio of methyl to methylene response area [CH₃/CH₂] from the ATREF infra-red detector, wherein the tallest (highest) peak is identified from the base line, and then the FWHM area is determined. For a distribution measured using an ATREF peak, the FWHM area is defined as the area under the curve between T₁ and T₂, where T₁ and T₂ are points determined, to the left and right of the ATREF peak, by dividing the peak height by two, and then drawing a line horizontal to the base line, that intersects the left and right portions of the ATREF curve. A calibration curve for comonomer content is made using random ethylene/ α -olefin copolymers, plotting comonomer content from NMR versus FWHM area ratio of the TREF peak. For this infra-red method, the calibration curve is generated for the same comonomer type of interest. The comonomer content of TREF peak of the inventive polymer can be determined by referencing this calibration curve using its FWHM methyl : methylene area ratio [CH₃/CH₂] of the TREF peak.

[0050] Comonomer content may be measured using any suitable technique, with techniques based on nuclear magnetic resonance (NMR) spectroscopy preferred. Using this technique, said blocked interpolymer has higher molar comonomer content than a corresponding comparable interpolymer.

[0051] Preferably, for interpolymers of ethylene and 1-octene, the block interpolymer has a comonomer content of the TREF fraction eluting between 40 and 130°C greater than or equal to the quantity $(-0.2013) T + 20.07$, more preferably greater than or equal to the quantity $(-0.2013) T - 21.07$, where T is the numerical value of the peak elution temperature of the TREF fraction being compared, measured in °C.

[0052] Figure 4 graphically depicts an embodiment of the block interpolymers of methylene and 1-octene where a plot of the comonomer content versus TREF elution temperature for several comparable ethylene/1-octene interpolymers (random copolymers) are fit to a line representing $(-0.2013) T + 20.07$ (solid line). The line for the equation $(-0.2013) T + 21.07$ is depicted by a dotted line. Also depicted are the comonomer contents for fractions of several block ethylene/1-octene interpolymers of the invention (multi-block copolymers). All of the block interpolymer fractions have significantly higher 1-octene content than either line at equivalent elution temperatures. This result is characteristic of the inventive interpolymer and is believed to be due to the presence of differentiated blocks within the polymer chains, having both crystalline and amorphous nature.

[0053] Figure 5 graphically displays the TREF curve and comonomer contents of polymer fractions for Example 5 and

Comparative F discussed below. The peak eluting from 40 to 130°C, preferably from 60°C to 95°C for both polymers is fractionated into three parts, each part eluting over a temperature range of less than 10°C. Actual data for Example 5 is represented by triangles. The skilled artisan can appreciate that an appropriate calibration curve may be constructed for interpolymers containing different comonomers and a line used as a comparison fitted to the TREF values obtained from comparative interpolymers of the same monomers, preferably random copolymers made using a metallocene or other homogeneous catalyst composition. Inventive interpolymers are characterized by a molar comonomer content greater than the value determined from the calibration curve at the same TREF elution temperature, preferably at least 5 percent greater, more preferably at least 10 percent greater.

[0054] In addition to the above aspects and properties described herein, the inventive polymers can be characterized by one or more additional characteristics. In one aspect, the inventive polymer is an olefin interpolymer, preferably comprising ethylene and one or more copolymerizable comonomers in polymerized form, characterized by multiple blocks or segments of two or more polymerized monomers units differing in chemical or physical properties (blocked interpolymer), most preferably a multi-block copolymer, said block interpolymer having a molecular fraction which elutes between 40°C and 130°C, when fractionated using TREF increments, characterized in that said fraction has a molar comonomer content higher, preferably at least 5 percent higher, more preferably at least 10, 15, 20 or 25 percent higher, than that of a comparable random ethylene interpolymer fraction eluting between the same temperatures, wherein said comparable random ethylene interpolymer comprises the same comonomer(s), preferably it is the same comonomer(s), and a melt index, density, and molar comonomers content (based on the whole polymer) within 10 percent of that of the blocked interpolymer. Preferably, the Mw/Mn of the comparable interpolymer is also within 10 percent of that of the blocked interpolymer and/or the comparable interpolymer has a total comonomer content within 10 weight percent of that of the blocked interpolymer.

[0055] Preferably, the above interpolymers are interpolymers of ethylene and at least one α -olefin, especially those interpolymers having a whole polymer density from 0.855 to 0.935 g/cm³, and more especially for polymers having more than 1 mole percent comonomer, the blocked interpolymer has a comonomer content of the TREF fraction eluting between 40 and 130°C greater than or equal to the quantity $(-0.1356) T + 13.89$, more preferably greater than or equal to the quantity $(-0.1356) T + 14.93$, and most preferably greater than or equal to the quantity $(-0.2013) T + 21.07$, where T is the numerical value of the peak ATREF elution temperature of the TREF fraction being compared, measured in °C.

[0056] Preferably, for the above interpolymers of ethylene and at least one alpha-olefin especially those interpolymers having a whole polymer density from 0.855 to 0.935 g/cm³, and more especially for polymers having more than 1 mole percent comonomer, the blocked interpolymer has a comonomer content of the TREF fraction eluting between 40 and 130°C greater than or equal to the quantity $(-0.2013) T + 20.07$, more preferably greater than or equal to the quantity $(-0.2013) T + 21.07$, where T is the numerical value of the peak elution temperature of the TREF fraction being compared, measured in °C.

[0057] In still another aspect, the inventive polymer is an olefin interpolymer, preferably comprising ethylene and one or more copolymerizable comonomers in polymerized form, characterized by multiple blocks or segments of two or more polymerized monomer units differing in chemical or physical properties (blocked interpolymer), most preferably a multi-block copolymer, said block interpolymer having a molecular fraction which elutes between 40°C and 130°C, when fractionated using TREF increments, characterized in that every fraction having a comonomers content of at least 6 mole percent, has a melting point greater than 100°C. For those fractions having a comonomer content from 3 mole percent to 6 mole percent, every fraction has a DSC melting point of 110°C or higher. More preferably, said polymer fraction, having at least 1 mole percent comonomer, has a DSC melting point that corresponds to the equation:

$$T_m \geq (-5.5926)(\text{mole percent comonomer in the fraction}) + 135.90.$$

[0058] In yet another aspect, the inventive polymer is an olefin interpolymer, preferably comprising ethylene and one or more copolymerizable comonomers in polymerized form, characterized by multiple blocks or segments of two or more polymerized monomer units differing in chemical or physical properties (blocked interpolymer), most preferably a multi-block copolymer, said block interpolymer having a molecular fraction which elutes between 40°C and 130°C, when fractionated using TREF increments, characterized in that every fraction that has an ATREF elution temperature greater than or equal to 76°C, has a melt enthalpy (heat of fusion) as measured by DSC, corresponding to the equation:

$$\text{Heat of fusion (J/gm)} \leq (3.1718)(\text{ATREF elution temperature in Celsius}) - 136.58,$$

[0059] The inventive block interpolymers have a molecular fraction which elutes between 40°C and 130°C, when fractionated using TREF increments, characterized in that every fraction that has an ATREF elution temperature between

40°C and less than 76°C, has a melt enthalpy (heat of fusion) as measured by DSC, corresponding to the equation:

$$\text{Heat of fusion (J/gm)} \leq (1.1312)(\text{ATREF elution temperature in Celsius}) + 22.97.$$

5

ATREF Peak Comonomer Composition Measurement by Infra-Red Detector

[0060] The comonomer composition of the TREF peak can be measured using an IR4 infra-red detector available from Polymer Char, Valencia, Spain (<http://www.polymerchar.com/>).

10 [0061] The "composition mode" of the detector is equipped with a measurement sensor (CH₂) and composition sensor (CH₃) that are fixed narrow band infra-red filters in the region of 2800-3000 cm⁻¹. The measurement sensor detects the methylene (CH₂) carbons on the polymer (which directly relates to the polymer concentration in solution) while the composition sensor detects the methyl (CH₃) groups of the polymer. The mathematical ratio of the composition signal (CH₃) divided by the measurement signal (CH₂) is sensitive to the comonomer content of the measured polymer in solution and its response is calibrated with known ethylene alpha-olefin copolymer standards.

15 [0062] The detector when used with an ATREF instrument provides both a concentration (CH₂) and composition (CH₃) signal response of the eluted polymer during the TREF process. A polymer specific calibration can be created by measuring the area ratio of the CH₃ to CH₂ for polymers with known comonomer content (preferably measured by NMR). The comonomer content of an ATREF peak of a polymer can be estimated by applying a the preference calibration of the ratio of the areas for the individual CH₃ and CH₂ response (i.e. area ratio CH₃/CH₂ versus comonomer content).

20 [0063] The area of the peaks can be calculated using a full width/half maximum (FWHM) calculation after applying the appropriate baselines to integrate the individual signal responses from the TREF chromatogram. The full width/half maximum calculation is based on the ratio of methyl to methylene response area [CH₃/CH₂] from the ATREF infrared detector, wherein the tallest (highest) peak is identified from the base line, and then the FWHM area is determined. For a distribution measured using an ATREF peak, the FWHM area is defined as the area under the curve between T1 and T2, where T1 and T2 are points determined, to the left and right of the ATREF peak, by dividing the peak height by two, and then drawing a line horizontal to the base line, that intersects the left and right portions of the ATREF curve.

25 [0064] The application of infra-red spectroscopy to measure the comonomer content of polymers in this ATREF-infra-red method is, in principle, similar to that of GPC/FTIR systems as described in the following references: Markovich, Ronald P.; Hazlitt, Lonnie G.; Smith, Linley; "Development of gel-permeation chromatography-Fourier transform infrared spectroscopy for characterization of ethylene-based polyolefin copolymers". Polymeric Materials Science and Engineering (1991), 65, 98-100; and Deslauriers, P.J.; Rohlfing, D.C.; Shieh, E.T.; "Quantifying short chain branching microstructures in ethylene-1-olefin copolymers using size exclusion chromatography and Fourier transform infrared spectroscopy (SEC-FTIR)", Polymer (2002), 43, 59-170.

30 [0065] In other embodiments, the inventive ethylene/α-olefin interpolymer is characterized by an average block index, ABI, which is greater than zero and up to 1.0 and a molecular weight distribution, M_w/M_n, greater than 1.3. The average block index, ABI, is the weight average of the block index ("BI") for each of the polymer fractions obtained in preparative TREF from 20°C and 110°C, with an increment of 5°C:

40

$$ABI = \sum(w_i BI_i)$$

45 where BI_i is the block index for the ith fraction of the inventive ethylene/α-olefin interpolymer obtained in preparative TREF, and w_i is the weight percentage of the ith fraction.

[0066] For each polymer fraction, BI is defined by one of the two following equations (both of which give the same BI value):

50

$$BI = \frac{1/T_X - 1/T_{X0}}{1/T_A - 1/T_{AB}} \quad \text{or} \quad BI = -\frac{\ln P_X - \ln P_{X0}}{\ln P_A - \ln P_{AB}}$$

55 where T_X is the preparative ATREF elution temperature for the ith fraction (preferably expressed in Kelvin), P_X is the ethylene mole fraction for the ith fraction, which can be measured by NMR or IR as described above. P_{AB} is the ethylene mole fraction of the whole ethylene/α-olefin interpolymer (before fractionation), which also can be measured by NMR or IR. T_A and P_A are the ATREF elution temperature and the ethylene mole fraction for pure "hard segments" (which

EP 2 102 396 B1

refer to the crystalline segments of the interpolymer). As a first order approximation, the T_A and P_A values are set to those for high density polyethylene homopolymer, if the actual values for the "hard segments" are not available. For calculations performed herein, T_A is 372°K, P_A is 1.

[0067] T_{AB} is the ATREF temperature for a random copolymer of the same composition and having an ethylene mole fraction of P_{AB} . T_{AB} can be calculated from the following equation:

$$\ln P_{AB} = \alpha/T_{AB} + \beta$$

where α and β are two constants which can be determined by calibration using a number of known random ethylene copolymers. It should be noted that α and β may vary from instrument to instrument. Moreover, one would need to create their own calibration curve with the polymer composition of interest and also in a similar molecular weight range as the fractions. There is a slight molecular weight effect. If the calibration curve is obtained from similar molecular weight ranges, such effect would be essentially negligible. In some embodiments, random ethylene copolymers satisfy the following relationship:

$$\ln P = -237.83/T_{ATREF} + 0.639$$

[0068] T_{XO} is the ATREF temperature for a random copolymer of the same composition and having an ethylene mole fraction of P_X . T_{XO} can be calculated from $\ln P_X = \alpha/T_{XO} + \beta$. Conversely, P_{XO} is the ethylene mole fraction for a random copolymer of the same composition and having an ATREF temperature of T_X , which can be calculated from $\ln P_{XO} = \alpha/T_X + \beta$.

[0069] Once the block index (BI) for each preparative TREF fraction is obtained, the weight average block index, ABI, for the whole polymer can be calculated. In particular ABI can be greater than zero but less than 0.3 or from 0.1 to 0.3. On the other hand, ABI can be greater than 0.3 and up to 1.0. Preferably, ABI should be in the range of from 0.4 to 0.7, from 0.5 to 0.7, or from 0.6 to 0.9. ABI can also be in the range of from 0.3 to 0.9, from 0.3 to 0.8, or from 0.3 to 0.7, from 0.3 to 0.6, from 0.3 to 0.5, or from 0.3 to 0.4. Further, ABI can be in the range of from 0.4 to 1.0, from 0.5 to 1.0, or from 0.6 to 1.0, from 0.7 to 1.0, from 0.8 to 1.0, or from 0.9 to 1.0.

[0070] Another characteristic of the inventive ethylene/ α -olefin interpolymer is that the inventive ethylene/ α -olefin interpolymer comprises at least one polymer fraction which can be obtained by preparative TREF, wherein the fraction has a block index greater than 0.1 and up to 1.0 and a molecular weight distribution, M_w/M_n , greater than 1.3. In some embodiments, the polymer fraction has a block index greater than 0.6 and up to 1.0, greater than 0.7 and up to 1.0, greater than 0.8 and up to 1.0, or greater than 0.9 and up to 1.0. The polymer fraction can have a block index greater than 0.1 and up to 1.0, greater than 0.2 and up to 1.0, greater than 0.3 and up to 1.0, greater than 0.4 and up to 1.0, or greater than 0.4 and up to 1.0. Further, the polymer fraction can have a block index greater than 0.1 and up to 0.5, greater than 0.2 and up to 0.5, greater than 0.3 and up to 0.5, or greater than 0.4 and up to 0.5. The polymer fraction may also have block index greater than 0.2 and up to 0.9, greater than 0.3 and up to 0.8, greater than 0.4 and up to 0.7, or greater than 0.5 and up to 0.6.

[0071] For copolymers of ethylene and an α -olefin, the inventive polymers preferably possess (1) a PDI of at least 1.3, more preferably at least 1.5, at least 1.7, or at least 2.0, and most preferably at least 2.6, up to a maximum value of 5.0, more preferably up to a maximum of 3.5, and especially up to a maximum of 2.7; (2) a heat of fusion of 80 J/g or less; (3) an ethylene content of at least 50 weight percent; (4) a glass transition temperature, T_g , of less than -25°C, more preferably less than -30°C; and/or (5) one and only one T_m .

[0072] Further, the inventive polymers can have, alone or in combination with any other properties disclosed herein, a storage modulus, G' , such that $\log(G')$ is greater than or equal to 400 kPa, preferably greater than or equal to 1.0 MPa at a temperature of 100°C. Moreover, the inventive polymers possess a relatively flat storage modulus as a function of temperature in the range from 0 to 100°C (illustrated in Figure 6) that is characteristic of block copolymers, and heretofore unknown for an olefin copolymer, especially a copolymer of ethylene and one or more C_{3-8} aliphatic α -olefins. (By the term "relatively flat" in this context is meant that $\log G'$ (in Pascals) decreases by less than one order of magnitude between 50 and 100°C, preferably between 0 and 100°C).

[0073] The inventive interpolymers may be further characterized by a thermomechanical analysis penetration depth of 1 mm at a temperature of at least 90°C as well as a flexural modulus of from 3 kpsi (20 MPa) to 13 kpsi (90 MPa). Alternatively, the inventive interpolymers can have a thermomechanical analysis penetration depth of 1 mm at a temperature of at least 104°C as well as a flexural modulus of at least 3 kpsi (20 MPa). They may be characterized as having an abrasion resistance (or volume loss) of less than 90 mm³. Figure 7 shows the TMA (1 mm) versus flex modulus for

the inventive polymers, as compared to other known polymers. The inventive polymers have significantly better flexibility-heat resistance balance than the other polymers.

[0074] Additionally, the ethylene/ α -olefin interpolymers can have a melt index, I_2 , from 0.01 to 2000 g/10 minutes, preferably from 0.01 to 1000 g/10 minutes, more preferably from 0.01 to 500 g/10 minutes, and especially from 0.01 to 100 g/10 minutes. In particular, the ethylene/ α -olefin interpolymers can have a melt index, I_2 , from 0.01 to 10 g/10 minutes, from 0.5 to 50 g/10 minutes, from 1 to 30 g/10 minutes, from 1 to 6 g/10 minutes or from 0.3 to 10 g/10 minutes. In certain embodiments, the melt index for the ethylene/ α -olefin polymers is 1g/10 minutes, 3 g/10 minutes or 5 g/10 minutes.

[0075] The polymers can have molecular weights, M_w , from 1,000 g/mole to 5,000,000 g/mole, preferably from 1000 g/mole to 1,000,000, more preferably from 10,000 g/mole to 500,000 g/mole, and especially from 10,000 g/mole to 300,000 g/mole. The density of the inventive polymers can be from 0.80 to 0.99 g/cm³ and preferably for ethylene containing polymers from 0.85 g/cm³ to 0.97 g/cm³. In certain embodiments, the density of the ethylene/ α -olefin polymers ranges from 0.860 to 0.925 g/cm³ or 0.867 to 0.910 g/cm³.

[0076] The process of making the polymers has been disclosed in the following patent applications; U.S. Provisional Application No. 60/553,906, filed March 17, 2004; U.S. Provisional Application No. 60/662,937, filed March 17, 2005; U.S. Provisional Application No. 60/662,939, filed March 17, 2005; U.S. Provisional Application No. 60/662,938, filed March 17, 2005; PCT Application No. PCT/US2005/008916, filed March 17, 2005; PCT Application No. PCT/US2005/008915, filed March 17, 2005; and PCT Application No. PCT/US2005/008917, filed March 17, 2005. For example, one such method comprises contacting ethylene and optionally one or more addition polymerizable monomers other than ethylene under addition polymerization conditions with a catalyst composition comprising:

the admixture or reaction product resulting from combining:

(A) a first olefin polymerization catalyst having a high comonomer incorporation index,

(B) a second olefin polymerization catalyst having a comonomer incorporation index less than 90 percent, preferably less than 50 percent, most preferably less than 5 percent of the comonomer incorporation index of catalyst (A), and

(C) a chain shuttling agent

[0077] Representative catalysts and chain shuttling agent are as follows.

[0078] Catalyst (A1) is [N-(2,6-di(1-methylethyl)phenyl)amido](2-isopropylphenyl)(α -naphthalen-2-yl)(6-pyridin-2-yl)methane)]hafnium dimethyl, prepared according to the teachings of WO 03/40195, 2003US0204017, USSN 10/429,024, filed May 2, 2003, and WO 04/24740.

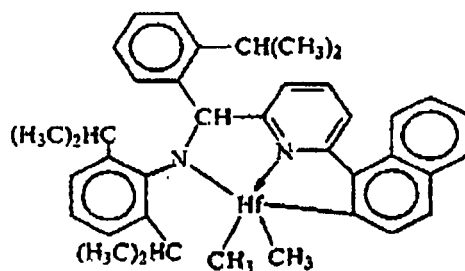

[0079] Catalyst (A2) is [N-(2,6-di(1-methylethyl)phenyl)amino](2-methylphenyl)(1,2-phenylene-(6-pyridin-2-yl)methane)]hafnium dimethyl, prepared according to the teachings of WO 03/40195, 2003US0204017, USSN 10/429,024, filed May 2, 2003, and WO 04/24740.

5
10
15
20
25
30
35
40
45
50
55

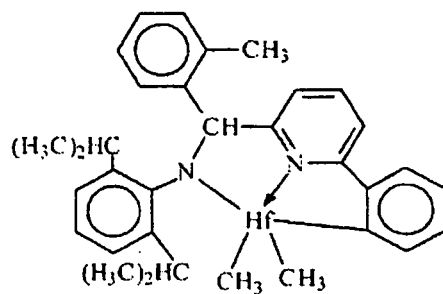

[0080] Catalyst (A3) is bis[N,N''-(2,4,6-tri(methylphenyl)amido)ethylenediamine]-hafnium dibenzyl.

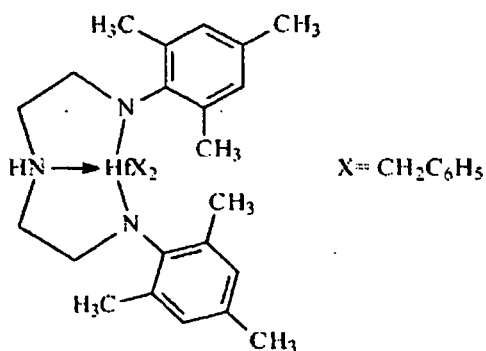

[0081] Catalyst (A4) is bis((2-oxoyl-3-(dibenzo-1H-pyrrole-1-yl)-5-(methyl)phenyl)-2-phenoxyethyl)cyclohexane-1,2-diyl zirconium (IV) dibenzyl, prepared substantially according to the teachings of US-A-2004/0010103.

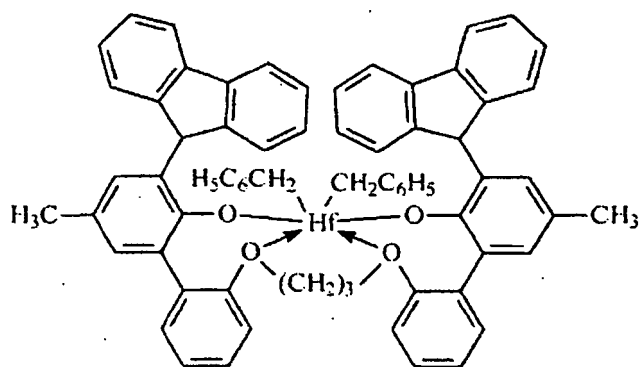

[0082] Catalyst (B1) is 1,2-bis-(3,5-di-t-butylphenylene)(1-(N-(1-methylethyl)imino)methyl)(2-oxoyl) zirconium dibenzyl

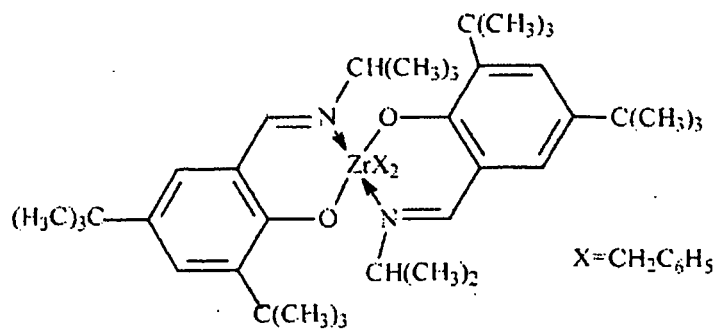

15 **[0083]** Catalyst (B2) is 1,2-bis-(3,5-di-*t*-butylphenylene)(1-(*N*-(2-methylcyclohexyl)-imino)methyl)(2-oxoyl) zirconium dibenzyl

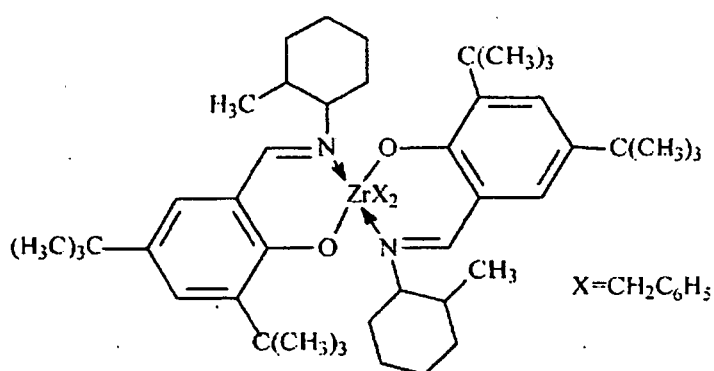

35 **[0084]** Catalyst (C1) is (*t*-butylamido)dimethyl(3-*N*-pyrrolyl-1,2,3,3a,7a- η -inden-1-yl)silane titanium dimethyl prepared substantially according to the techniques of USP 6,268,444:

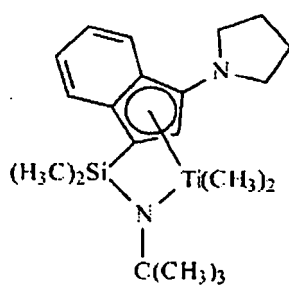

50 **[0085]** Catalyst (C2) is (*t*-butylamido)di(4-methylphenyl)(2-methyl-1,2,3a,7a- η -inden-1-yl)silane titanium dimethyl prepared substantially according to the teachings of US-A-2003/004286:

55

5

10

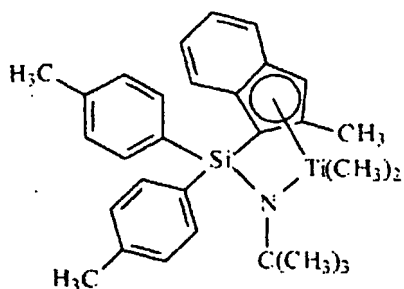

15 **[0086]** Catalyst (C3) is (t-butylamido)di(4-methylphenyl)(2-methyl-1,2,3,3a,8a-η-s-indacen-1-yl)silane titanium dimethyl prepared substantially according to the teachings of US-A=2003/004286:

20

25

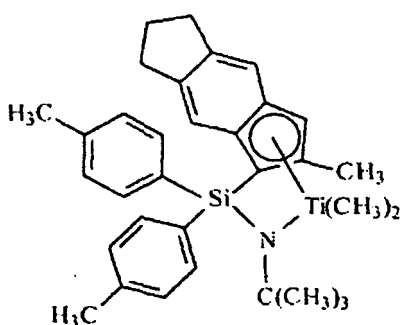

30

[0087] Catalyst (D1) is bis(dimethyldisiloxane)(indene-1-yl)zirconium dichloride available from Sigma-Aldrich:

35

40

45

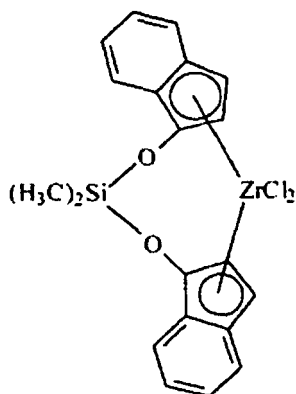

50 **[0088] Shuttling Agents** The shuttling agents employed include diethylzinc, di(i-butyl)zinc, di(n-hexyl)zinc, triethylaluminum, trioctylaluminum, triethylgallium, i-butylaluminum bis(dimethyl(t-butyl)siloxane), i-butylaluminum bis(di(trimethylsilyl)amide), n-octylaluminum di(pyridine-2-methoxide), bis(n-octadecyl)i-butylaluminum, i-butylaluminum bis(di(n-pentyl)amide), n-octylaluminum bis(2,6-di-t-butylphenoxide), n-octylaluminum di(ethyl(1-naphthyl)amide), ethylaluminum bis(t-butyl)dimethylsiloxide, ethylaluminum di(bis(trimethylsilyl)amide), ethylaluminum bis(2,3,6,7-dibenzo-1-azacycloheptaneamide), n-octylaluminum bis(2,3,6,7-dibenzo-1-azacycloheptaneamide), n-octylaluminum bis(dimethyl(t-butyl)siloxide), ethylzinc (2,6-diphenylphenoxide), and ethylzinc (t-butoxide).

55 **[0089]** Preferably, the foregoing process takes the form of a continuous solution process, for forming block copolymers, especially multi-block copolymers, preferably linear multi-block copolymers of two or more monomers, more especially ethylene and a C₃₋₂₀ olefin or cycloolefin, and most especially ethylene and a C₄₋₂₀ α-olefin, using multiple catalysts that are incapable of interconversion. That is, the catalysts are chemically distinct. Under continuous solution polymerization conditions, the process is ideally suited for polymerization of mixtures of monomers at high monomer conversions.

Under these polymerization conditions, shuttling from the chain shuttling agent to the catalyst becomes advantaged compared to chain growth, and multi-block copolymers, especially linear multiblock copolymers are formed in high efficiency.

5 [0090] The inventive interpolymers may be differentiated from conventional, random copolymers, physical blends of polymers, and block copolymers prepared via sequential monomer addition, fluxional catalysts, anionic or cationic living polymerization techniques. In particular, compared to a random copolymer of the same monomers and monomer content at equivalent crystallinity or modulus, the inventive interpolymers have better (higher) heat resistance as measured by melting point, higher TMA penetration temperature, higher high-temperature tensile strength, and/or higher high-temperature torsion storage modulus as determined by dynamic mechanical analysis. Compared to a random copolymer containing the same monomers and monomer content, the inventive interpolymers have lower compression set, particularly at elevated temperatures, lower stress relaxation, higher creep resistance, higher tear strength, higher blocking resistance, faster setup due to higher crystallization (solidification.) temperature, higher recovery (particularly at elevated temperatures), better abrasion resistance, higher retractive force, and better oil and filler acceptance.

10 [0091] The inventive interpolymers also exhibit a unique crystallization and branching distribution relationship. That is, the inventive interpolymers have a relatively large difference between the tallest peak temperature measured using CRYSTAF and DSC as a function of heat of fusion, especially as compared to random copolymers containing the same monomers and monomer level or physical blends of polymers, such as a blend of a high density polymer and a lower density copolymer, at equivalent overall density. It is believed that this unique feature of the inventive interpolymers is due to the unique distribution of the comonomer in blocks within the polymer backbone. In particular, the inventive interpolymers may comprise alternating blocks of differing comonomer content (including homopolymer blocks). The inventive interpolymers may also comprise a distribution in number and/or block size of polymer blocks of differing density or comonomer content, which is a Schultz-Flory type of distribution. In addition, the inventive interpolymers also have a unique peak melting point and crystallization temperature profile that is substantially independent of polymer density, modulus, and morphology. Preferably, the microcrystalline order of the polymers demonstrates characteristic spherulites and lamellae that are distinguishable from random or block copolymers, even at PDI values that are less than 1.7, or even less than 1.5, down to less than 1.3.

15 [0092] Moreover, the inventive interpolymers may be prepared using techniques to influence the degree or level of blockiness. That is the amount of comonomer and length of each polymer block or segment can be altered by controlling the ratio and type of catalysts and shuttling agent as well as the temperature of the polymerization, and other polymerization variables. A surprising benefit of this phenomenon is the discovery that as the degree of blockiness is increased, the optical properties, tear strength, and high temperature recovery properties of the resulting polymer are improved. In particular, haze decreases while clarity, tear strength, and high temperature recovery properties increase as the average number of blocks in the polymer increases. By selecting shuttling agents and catalyst combinations having the desired chain transferring ability (high rates of shuttling with low levels of chain termination) other forms of polymer termination are effectively suppressed. Accordingly, little if any β -hydride elimination is observed in the polymerization of ethylene/ α -olefin comonomer mixtures according to embodiments of the invention, and the resulting crystalline blocks are highly, or substantially completely, linear, possessing little or no long chain branching.

20 [0093] Polymers with highly crystalline chain ends can be selectively prepared in accordance with embodiments of the invention. In elastomer applications, reducing the relative quantity of polymer that terminates with an amorphous block reduces the intermolecular dilutive effect on crystalline regions. This result can be obtained by choosing chain shuttling agents and catalysts having an appropriate response to hydrogen or other chain terminating agents. Specifically, if the catalyst which produces highly crystalline polymers is more susceptible to chain termination (such as by use of hydrogen) than the catalyst responsible for producing the less crystalline polymer segment (such as through higher comonomer incorporation, regio-error, or atactic polymer formation), then the highly crystalline polymer segments will preferentially populate the terminal portions of the polymer. Not only are the resulting terminated groups crystalline, but upon termination, the highly crystalline polymer forming catalyst site is once again available for reinitiation of polymer formation. The initially formed polymer is therefore another highly crystalline polymer segment. Accordingly, both ends of the resulting multi-block copolymer are preferentially highly crystalline.

25 [0094] The ethylene α -olefin interpolymers used in the embodiments of the invention are preferably interpolymers of ethylene with at least one C_3 - C_{20} α -olefin. Copolymers of ethylene and a C_3 - C_{20} α -olefin are especially preferred. The interpolymers may further comprise C_4 - C_{18} diolefin and/or alkenylbenzene. Suitable unsaturated comonomers useful for polymerizing with ethylene include, for example, ethylenically unsaturated monomers, conjugated or nonconjugated dienes, polyenes, alkenylbenzenes, etc. Examples of such comonomers include C_3 - C_{20} α -olefins such as propylene, isobutylene, 1-butene, 1-hexene, 1-pentene, 4-methyl-1-pentene, 1-heptene, 1-octene, 1-nonene, 1-decene, and the like. 1-butene and 1-octene are especially preferred. Other suitable monomers include styrene, halo- or alkyl-substituted styrenes, vinylbenzocyclobutane, 1,4-hexadiene, 1,7-octadiene, and naphthenics (e.g., cyclopentene, cyclohexene and cyclooctene).

30 [0095] While ethylene/ α -olefin interpolymers are preferred polymers, other ethylene/olefin polymers may also be used.

Olefins as used herein refer to a family of unsaturated hydrocarbon-based compounds with at least one carbon-carbon double bond. Depending on the selection of catalysts, any olefin may be used in embodiments of the invention. Preferably, suitable olefins are C₃-C₂₀ aliphatic and aromatic compounds containing vinylic unsaturation, as well as cyclic compounds, such as cyclobutene, cyclopentene, dicyclopentadiene, and norbornene, including but not limited to, norbornene substituted in the 5 and 6 position with C₁-C₂₀ hydrocarbyl or cyclohydrocarbyl groups. Also included are mixtures of such olefins as well as mixtures of such olefins with C₄-C₄₀ diolefin compounds.

[0096] Examples of olefin monomers include, but are not limited to propylene, isobutylene, 1-butene, 1-pentene, 1-hexene, 1-heptene, 1-octene, 1-nonene, 1-decene, and 1-dodecene, 1-tetradecene, 1-hexadecene, 1-octadecene, 1-eicosene, 3-methyl-1-butene, 3-methyl-1-pentene, 4-methyl-1-pentene, 4,6-dimethyl-1-heptene, 4-vinylcyclohexene, vinylcyclohexane, norbornadiene, ethylidene norbornene, cyclopentene, cyclohexene, dicyclopentadiene, cyclooctene, C₄-C₄₀ dienes, including but not limited to 1,3-butadiene, 1,3-pentadiene, 1,4-hexadiene, 1,5-hexadiene, 1,7-octadiene, 1,9-decadiene, other C₄-C₄₀ α -olefins, and the like. In certain embodiments, the α -olefin is propylene, 1-butene, 1-pentene, 1-hexene, 1-octene or a combination thereof. Although any hydrocarbon containing a vinyl group potentially may be used in embodiments of the invention, practical issues such as monomer availability, cost, and the ability to conveniently remove unreacted monomer from the resulting polymer may become more problematic as the molecular weight of the monomer becomes too high.

[0097] The polymerization processes described herein are well suited for the production of olefin polymers comprising monovinylidene aromatic monomers including styrene, o-methyl styrene, p-methyl styrene, t-butylstyrene, and the like. In particular, interpolymers comprising ethylene and styrene can be prepared by following the teachings herein. Optionally, copolymers comprising ethylene, styrene and a C₃-C₂₀ alpha olefin, optionally comprising a C₄-C₂₀ diene, having improved properties can be prepared.

[0098] Suitable non-conjugated diene monomers can be a straight chain, branched chain or cyclic hydrocarbon diene having from 6 to 15 carbon atoms. Examples of suitable non-conjugated dienes include, but are not limited to, straight chain acyclic dienes, such as 1,4-hexadiene, 1,6-octadiene, 1,7-octadiene, 1,9-decadiene, branched chain acyclic dienes, such as 5-methyl-1,4-hexadiene; 3,7-dimethyl-1,6-octadiene; 3,7-dimethyl-1,7-octadiene and mixed isomers of dihydromyrcene and dihydrocinene, single ring alicyclic dienes, such as 1,3-cyclopentadiene; 1,4-cyclohexadiene; 1,5-cyclooctadiene and 1,5-cyclododecadiene, and multi-ring alicyclic fused and bridged ring dienes, such as tetrahydroindene, methyl tetrahydroindene, dicyclopentadiene, bicyclo-(2,2,1)-hepta-2,5-diene; alkenyl, alkylidene, cycloalkenyl and cycloalkylidene norbornenes, such as 5-methylene-2-norbornene (MNB); 5-propenyl-2-norbornene, 5-isopropylidene-2-norbornene, 5-(4-cyclopentenyl)-2-norbornene, 5-cyclohexylidene-2-norbornene, 5-vinyl-2-norbornene, and norbornadiene. Of the dienes typically used to prepare EPDMs, the particularly preferred dienes are 1,4-hexadiene (HD), 5-ethylidene-2-norbornene (ENB), 5-vinylidene-2-norbornene (VNB), 5-methylene-2-norbornene (MNB), and dicyclopentadiene (DCPD). The especially preferred dienes are 5-ethylidene-2-norbornene (ENB) and 1,4-hexadiene (HD).

[0099] One class of desirable polymers that can be made for use in the invention are elastomeric interpolymers of ethylene, a C₃-C₂₀ α -olefin, especially propylene, and optionally one or more diene monomers. Preferred α -olefins for use in this embodiment of the present invention are designated by the formula CH₂=CHR^{*}, where R^{*} is a linear or branched alkyl group of from 1 to 12 carbon atoms. Examples of suitable α -olefins include, but are not limited to, propylene, isobutylene, 1-butene, 1-pentene, 1-hexene, 4-methyl-1-pentene, and 1-octene. A particularly preferred α -olefin is propylene. The propylene based polymers are generally referred to in the art as EP or EPDM polymers. Suitable dienes for use in preparing such polymers, especially multi-block EPDM type polymers include conjugated or non-conjugated, straight or branched chain-, cyclic- or polycyclic- dienes comprising from 4 to 20 carbons. Preferred dienes include 1,4-pentadiene, 1,4-hexadiene, 5-ethylidene-2-norbornene, dicyclopentadiene, cyclohexadiene, and 5-butylidene-2-norbornene. A particularly preferred diene is 5-ethylidene-2-norbornene,

[0100] Because the diene containing polymers comprise alternating segments or blocks containing greater or lesser quantities of the diene (including none) and α -olefin (including none), the total quantity of diene and α -olefin may be reduced without loss of subsequent polymer properties. That is, because the diene and α -olefin monomers are preferentially incorporated into one type of block of the polymer rather than uniformly or randomly throughout the polymer, they are more efficiently utilized and subsequently the crosslink density of the polymer can be better controlled. Such crosslinkable elastomers and the cured products have advantaged properties, including higher tensile strength and better elastic recovery.

[0101] The inventive interpolymers can also be made with two catalysts incorporating differing quantities of comonomer have a weight ratio of blocks formed thereby from 95:5 to 5:95. The elastomeric polymers desirably have an ethylene content of from 20 to 90 percent, a diene content of from 0.1 to 10 percent, and an α -olefin content of from 10 to 80 percent, based on the total weight of the polymer. Further preferably, the multi-block elastomeric polymers have an ethylene content of from 60 to 90 percent, a diene content of from 0.1 to 10 percent, and an α -olefin content of from 10 to 40 percent, based on the total weight of the polymer. Preferred polymers are high molecular weight polymers, having a weight average molecular weight (Mw) from 10,000 to 2,500,000, preferably from 20,000 to 500,000, more preferably from 20,000 to 330,000, and a polydispersity less than 3.5, more preferably less than 3.0, and a Mooney viscosity (ML

(1+4) 125°C.) from 1 to 250. More preferably, such polymers have an ethylene content from 65 to 75 percent, a diene content from 0 to 6 percent, and an α -olefin content from 20 to 35 percent.

[0102] The ethylene/ α -olefin interpolymers can be functionalized by incorporating at least one functional group in its polymer structure. Exemplary functional groups may include, for example, ethylenically unsaturated mono- and di-functional carboxylic acids, ethylenically unsaturated mono- and di-functional carboxylic acid anhydrides, salts thereof and esters thereof. Such functional groups may be grafted to an ethylene/ α -olefin interpolymer, or it may be copolymerized with ethylene and an optional additional comonomer to form an interpolymer of ethylene, the functional comonomer and optionally other comonomer(s). Means for grafting functional groups onto polyethylene are described for example in U.S. Patents Nos. 4,762,890, 4,927,888, and 4,950,541.

One particularly useful functional group is malic anhydride.

[0103] The amount of the functional group present in the functional interpolymer can vary. The functional group can typically be present in a copolymer-type functionalized interpolymer in an amount of at least 1.0 weight percent, preferably at least 5 weight percent, and more preferably at least 7 weight percent. The functional group will typically be present in a copolymer-type functionalized interpolymer in an amount less than 40 weight percent, preferably less than 30 weight percent, and more preferably less than 25 weight percent.

Testing Methods

[0104] In the examples that follow, the following analytical techniques are employed:

GPC Method for Samples 1-4 and A-C

[0105] An automated liquid-handling robot equipped with a heated needle set to 160°C is used to add enough 1,2,4-trichlorobenzene stabilized with 300 ppm Ionol to each dried polymer sample to give a final concentration of 30 mg/mL. A small glass stir rod is placed into each tube and the samples are heated to 160°C for 2 hours on a heated, orbital-shaker rotating at 250 rpm. The concentrated polymer solution is then diluted to 1 mg/ml using the automated liquid-handling robot and the heated needle set to 160°C,

[0106] A Symyx Rapid GPC system is used to determine the molecular weight data for each sample. A Gilson 350 pump set at 2.0 ml/min flow rate is used to pump helium-purged 1,2-dichlorobenzene stabilized with 300 ppm Ionol as the mobile phase through three Pigel 10 micrometer (μ m) Mixed B 300mm x 7.5mm columns placed in series and heated to 160°C. A Polymer Labs ELS 1000 Detector is used with the Evaporator set to 250°C, the Nebulizer set to 165°C, and the nitrogen flow rate set to 1.8 SLM at a pressure of 60-80 psi (400-600 kPa) N₂. The polymer samples are heated to 160°C and each sample injected into a 250 μ l loop using the liquid-handling robot and a heated needle. Serial analysis of the polymer samples using two switched loops and overlapping injections are used. The sample data is collected and analyzed using Symyx Epoch™ software. Peaks are manually integrated and the molecular weight information reported uncorrected against a polystyrene standard calibration curve.

Standard CRYSTAF Method

[0107] Branching distributions are determined by crystallization analysis fractionation (CRYSTAF) using a CRYSTAF 200 unit commercially available from PolymerChar, Valencia, Spain. The samples are dissolved in 1,2,4 trichlorobenzene at 160°C (0.66 mg/mL) for 1 hour and stabilized at 95°C for 45 minutes. The sampling temperatures range from 95 to 30°C at a cooling rate of 0.2°C/min. An infrared detector is used to measure the polymer solution concentrations. The cumulative soluble concentration is measured as the polymer crystallizes while the temperature is decreased. The analytical derivative of the cumulative profile reflects the short chain branching distribution of the polymer.

[0108] The CRYSTAF peak temperature and area are identified by the peak analysis module included in the CRYSTAF Software (Version 2001.b, PolymerChar, Valencia, Spain). The CRYSTAF peak finding routine identifies a peak temperature as a maximum in the dW/dT curve and the area between the largest positive inflections on either side of the identified peak in the derivative curve. To calculate the CRYSTAF curve, the preferred processing parameters are with a temperature limit of 70°C and with smoothing parameters above the temperature limit of 0.1, and below the temperature limit of 0.3.

DSC Standard Method (Excluding Samples 1-4 and A-C)

[0109] Differential Scanning Calorimetry results are determined using a TAI model Q1000 DSC equipped with an RCS cooling accessory and an autosampler. A nitrogen purge gas flow of 50 ml/min is used. The sample is pressed into a thin film and melted in the press at about 175°C and then air-cooled to room temperature (25°C). 3-10 mg of material is then cut into a 6 mm diameter disk, accurately weighed, placed in a light aluminum pan (ca 50 mg), and then crimped

EP 2 102 396 B1

shut. The thermal behavior of the sample is investigated with the following temperature profile. The sample is rapidly heated to 180°C and held isothermal for 3 minutes in order to remove any previous thermal history. The sample is then cooled to -40°C at 10°C/min cooling rate and held at -40°C for 3 minutes. The sample is then heated to 150°C at 10°C/min. heating rate. The cooling and second heating curves are recorded.

5 [0110] The DSC melting peak is measured as the maximum in heat flow rate (W/g) with respect to the linear baseline drawn between -30°C and end of melting. The heat of fusion is measured as the area under the melting curve between -30°C and the end of melting using a linear baseline.

10 GPC Method (Excluding Samples 1-4 and A-C)

[0111] The gel permeation chromatographic system consists of either a Polymer Laboratories Model PL-210 or a Polymer Laboratories Model PL-220 instrument. The column and carousel compartments are operated at 140°C. Three Polymer Laboratories 10-micron Mixed-B columns are used. The solvent is 1,2,4 trichlorobenzene. The samples are prepared at a concentration of 0.1 grams of polymer in 50 milliliters of solvent containing 200 ppm of butylated hydroxytoluene (BHT). Samples are prepared by agitating lightly for 2 hours at 160°C. The injection volume used is 100 microliters and the flow rate is 1.0 ml/minute.

15 [0112] Calibration of the GPC column set is performed with 21 narrow molecular weight distribution polystyrene standards with molecular weights ranging from 580 to 8,400,000, arranged in 6 "cocktail" mixtures with at least a decade of separation between individual molecular weights. The standards are purchased from Polymer Laboratories (Shropshire, UK). The polystyrene standards are prepared at 0.025 grams in 50 milliliters of solvent for molecular weights equal to or greater than 1,000,000, and 0.05 grams in 50 milliliters of solvent for molecular weights less than 1,000,000. The polystyrene standards are dissolved at 80°C with gentle agitation for 30 minutes. The narrow standards mixtures are run first and in order of decreasing highest molecular weight component to minimize degradation. The polystyrene standard peak molecular weights are converted to polyethylene molecular weights using the following equation (as described in Williams and Ward, J. Polym. Sci., Polym. Let., 6. 621 (1968)): $M_{\text{polyethylene}} = 0.431 (M_{\text{polystyrene}})$.

20 [0113] Polyethylene equivalent molecular weight calculations are performed using Viscotek TriSEC software Version 3.0.

30 Compression Set

[0114] Compression set is measured according to ASTM D 395. The sample is prepared by stacking 25.4 mm diameter round discs of 3.2 mm, 2.0 mm, and 0.25 mm thickness until a total thickness of 12.7 mm is reached. The discs are cut from 12.7 cm x 12.7 cm compression molded plaques molded with a hot press under the following conditions: zero pressure for 3 minutes at 190°C, followed by 86 MPa for 2 minutes at 190°C, followed by cooling inside the press with cold running water at 86 MPa.

Density

40 [0115] Samples for density measurement are prepared according to ASTM D 1928. Measurements are made within one hour of sample pressing using ASTM D792, Method B.

Flexural/Secant Modulus/ Storage Modulus

45 [0116] Samples are compression molded using ASTM D 1928. Flexural and 2 percent secant moduli are measured according to ASTM D-790. Storage modulus is measured according to ASTM D 5026-01 or equivalent technique.

Optical properties

50 [0117] Films of 0.4 mm thickness are compression molded using a hot press (Carver Model #4095-4PR1001 R). The pellets are placed between polytetrafluoroethylene sheets, heated at 190°C at 55 psi (380 kPa) for 3 minutes, followed by 1.3 MPa for 3 minutes, and then 2.6 MPa for 3 minutes. The film is then cooled in the press with running cold water at 1.3 MPa for 1 minute. The compression molded films are used for optical measurements, tensile behavior, recovery, and stress relaxation.

[0118] Clarity is measured using BYK Gardner Haze-gard as specified in ASTM D 1746.

55 [0119] 45° gloss is measured using BYK Gardner Glossmeter Microgloss 45° as specified in ASTM D-2457.

[0120] Internal haze is measured using BYK Gardner Haze-gard based on ASTM D 1003 Procedure A. Mineral oil is applied to the film surface to remove surface scratches.

Mechanical Properties - Tensile, Hysteresis, and Tear

[0121] Stress-strain behavior in uniaxial tension is measured using ASTM D 1708 microtensile specimens. Samples are stretched with an Instron at 500% min⁻¹ at 21°C. Tensile strength and elongation at break are reported from an average of 5 specimens:

[0122] 100% and 300% Hysteresis is determined from cyclic loading to 100% and 300% strains using ASTM D 1708 microtensile specimens with an Instron™ instrument. The sample is loaded and unloaded at 267 % min⁻¹ for 3 cycles at 21°C. Cyclic experiments at 300% and 80°C are conducted using an environmental chamber. In the 80°C experiment, the sample is allowed to equilibrate for 45 minutes at the test temperature before testing. In the 21°C, 300% strain cyclic experiment, the retractive stress at 150% strain from the first unloading cycle is recorded. Percent recovery for all experiments are calculated from the first unloading cycle using the strain at which the load returned to the base line. The percent recovery is defined as:

$$\% \text{ Recovery} = \frac{\varepsilon_f - \varepsilon_s}{\varepsilon_f} \times 100$$

where ε_f is the strain taken for cyclic loading and ε_s is the strain where the load returns to the baseline during the 1st unloading cycle.

[0123] Stress relaxation is measured at 50 percent strain and 37°C for 12 hours using an Instron™ instrument equipped with an environmental chamber. The gauge geometry was 76 mm x 25 mm x 0.4 mm. After equilibrating at 37°C for 45 min in the environmental chamber, the sample was stretched to 50% strain at 333% min⁻¹. Stress was recorded as a function of time for 12 hours. The percent stress relaxation after 12 hours was calculated using the formula:

$$\% \text{ Stress Relaxation} = \frac{L_0 - L_{12}}{L_0} \times 100$$

where L_0 is the load at 50% strain at 0 time and L_{12} is the load at 50 percent strain after 12 hours.

[0124] Tensile notched tear experiments are carried out on samples having a density of 0.88 g/cc or less using an Instron™ instrument. The geometry consists of a gauge section of 76 mm x 13 mm x 0.4 mm with a 2 mm notch cut into the sample at half the specimen length. The sample is stretched at 508 mm min⁻¹ at 21 °C until it breaks. The tear energy is calculated as the area under the stress-elongation curve up to strain at maximum load. An average of at least 3 specimens are reported.

TMA

[0125] Thermal Mechanical Analysis (Penetration Temperature) is conducted on 30mm diameter x 3.3 mm thick, compression molded discs, formed at 180°C and 10 MPa molding pressure for 5 minutes and then air quenched. The instrument used is a TMA 7, brand available from Perkin-Elmer. In the test, a probe with 1.5 mm radius tip (P/N N519-0416) is applied to the surface of the sample disc with 1N force. The temperature is raised at 5°C/min from 25°C. The probe penetration distance is measured as a function of temperature. The experiment ends when the probe has penetrated 1 mm into the sample.

DMA

[0126] Dynamic Mechanical Analysis (DMA) is measured on compression molded disks formed in a hot press at 180°C at 10 MPa pressure for 5 minutes and then water cooled in the press at 90°C / min. Testing is conducted using an ARES controlled strain rheometer (TA instruments) equipped with dual cantilever fixtures for torsion testing.

[0127] A 1.5mm plaque is pressed and cut in a bar of dimensions 32x12mm. The sample is clamped at both ends between fixtures separated by 10mm (grip separation ΔL) and subjected to successive temperature steps from -100°C to 200°C (5°C per step). At each temperature the torsion modulus G' is measured at an angular frequency of 10 rad/s, the strain amplitude being maintained between 0.1 percent and 4 percent to ensure that the torque is sufficient and that the measurement remains in the linear regime.

[0128] An initial static force of 10 g is maintained (auto-tension mode) to prevent slack in the sample when thermal expansion occurs. As a consequence, the grip separation ΔL increases with the temperature, particularly above the

EP 2 102 396 B1

melting or softening point of the polymer sample. The test stops at the maximum temperature or when the gap between the fixtures reaches 65 mm.

Melt Index

[0129] Melt index, or I_2 , is measured in accordance with ASTM D 1238, Condition 190°C/2.16 kg. Melt index, or I_{10} is also measured in accordance with ASTM D 1238, Condition 190°C/10 kg.

ATREF

[0130] Analytical temperature rising elution fractionation (ATREF) analysis is conducted according to the method described in U.S. Patent No. 4,798,081 and Wilde, L.; Ryle, T.R.; Knobloch, D.G.; Peat, I.R.; Determination of Branching Distributions in Polyethylene and Ethylene Copolymers, J. Polym. Sci., 20, 441-d55 (1982).

The composition to be analyzed is dissolved in trichlorobenzene and allowed to crystallize in a column containing an inert support (stainless steel shot) by slowly reducing the temperature to 20°C at a cooling rate of 0.1°C/min. The column is equipped with an infrared detector. An ATREF chromatogram curve is then generated by eluting the crystallized polymer sample from the column by slowly increasing the temperature of the eluting solvent (trichlorobenzene) from 20 to 120°C at a rate of 1.5°C/min.

^{13}C NMR Analysis

[0131] The samples are prepared by adding approximately 3g of a 50/50 mixture of tetrachloroethane- d_2 /orthodichlorobenzene to 0.4 g sample in a 10 mm NMR tube. The samples are dissolved and homogenized by heating the tube and its contents to 150°C. The data are collected using a JEOL Eclipse™ 400MHz spectrometer or a Varian Unity Plus™ 400MHz spectrometer, corresponding to a ^{13}C resonance frequency of 100.5 MHz. The data are acquired using 4000 transients per data file with a 6 second pulse repetition delay. To achieve minimum signal-to-noise for quantitative analysis, multiple data files are added together. The spectral width is 25,000 Hz with a minimum file size of 32K data points. The samples are analyzed at 130 °C in a 10 mm broad band probe. The comonomer incorporation is determined using Randall's triad method (Randall, J.C.; JMS-Rev. Macromol. Chem. Phys., C29, 201-317 (1989).

Polymer Fractionation by TREF

[0132] Large-scale TREF fractionation is carried by dissolving 15-20 g of polymer in 2 liters of 1,2,4-trichlorobenzene (TCB) by stirring for 4 hours at 160°C. The polymer solution is forced by 15 psig (100 kPa) nitrogen onto a 3 inch by 4 foot (7.6 cm x 12 cm) steel column packed with a 60:40 (v:v) mix of 30-40 mesh (600-425 μm) spherical, technical quality glass beads (available from Potters Industries, HC 30 Box 20, Brownwood, TX, 76801) and stainless steel, 0.028" (0.7mm) diameter cut wire shot (available from Pellets, Inc. 63 Industrial Drive, North Tonawanda, NY, 14120). The column is immersed in a thermally controlled oil jacket, set initially to 160°C. The column is first cooled ballistically to 125°C, then slow cooled to 20°C at 0.04°C per minute and held for one hour. Fresh TCB is introduced at about 65 ml/min while the temperature is increased at 0.167°C per minute.

[0133] Approximately 2000 ml portions of eluant from the preparative TREF column are collected in a 16 station, heated fraction collector. The polymer is concentrated in each fraction using a rotary evaporator until 50 to 100 ml of the polymer solution remains. The concentrated solutions are allowed to stand overnight before adding excess methanol, filtering, and rinsing (approx. 300-500 ml of methanol including the final rinse). The filtration step is performed on a 3 position vacuum assisted filtering station using 5.0 μm polytetrafluoroethylene coated filter paper (available from Osmonics Inc., Cat# Z50WP0470). The filtrated fractions are dried overnight in a vacuum oven at 60°C and weighed on an analytical balance before further testing.

Melt Strength

[0134] Melt Strength (MS) is measured by using a capillary rheometer fitted with a 2.1 mm diameter, 20:1 die with an entrance angle of approximately 45 degrees. After equilibrating the samples at 190°C for 10 minutes, the piston is run at a speed of 1 inch/minute (2.54 cm/minute). The standard test temperature is 190°C. The sample is drawn uniaxially to a set of accelerating nips located 100 mm below the die with an acceleration of 2.4 mm/sec². The required tensile force is recorded as a function of the take-up speed of the nip rolls. The maximum tensile force attained during the test is defined as the melt strength. In the case of polymer melt exhibiting draw resonance, the tensile force before the onset of draw resonance was taken as melt strength. The melt strength is recorded in centiNewtons ("cN").

Catalysts

[0135] The term "overnight", if used, refers to a time of approximately 16-18 hours, the term "room temperature", refers to a temperature of 20-25 °C, and the term "mixed alkanes" refers to a commercially obtained mixture of C₆₋₉ aliphatic hydrocarbons available under the trade designation Isopar E®, from ExxonMobil Chemical Company. In the event the name of a compound herein does not conform to the structural representation thereof the structural representation shall control. The synthesis of all metal complexes and the preparation of all screening experiments were carried out in a dry nitrogen atmosphere using dry box techniques. All solvents used were HPLC grade and were dried before their use.

[0136] MMAO refers to modified methylalumoxane, a triisobutylaluminum modified methylalumoxane available commercially from Akzo-Noble Corporation.

[0137] The preparation of catalyst (B1) is conducted as follows.

a) Preparation of (1-methylethyl)(2-hydroxy-3,5-di(t-butyl)phenyl)methylimine

[0138] 3,5-Di-t-butylsalicylaldehyde (3.00 g) is added to 10 mL of isopropylamine. The solution rapidly turns bright yellow. After stirring at ambient temperature for 3 hours, volatiles are removed under vacuum to yield a bright yellow, crystalline solid (97 percent yield).

b) Preparation of 1,2-bis-(3,5-di-t-butylphenylene)(1-(N-(1-methylethyl)imino)methyl)(2-oxoyl) zirconium dibenzyl

[0139] A solution of (1-methylethyl)(2-hydroxy-3,5-di(t-butyl)phenyl)imine (605 mg, 2.2 mmol) in 5 mL toluene is slowly added to a solution of Zr(CH₂Ph)₄ (500 mg, 1.1 mmol) in 50 mL toluene. The resulting dark yellow solution is stirred for 30 minutes. Solvent is removed under reduced pressure to yield the desired product as a reddish-brown solid.

[0140] The preparation of catalyst (B2) is conducted as follows.

a) Preparation of (1-(2-methylcyclohexyl)ethyl)(2-oxoyl-3,5-di(t-butyl)phenyl)imine

[0141] 2-Methylcyclohexylamine (8.44 mL, 64.0 mmol) is dissolved in methanol (90 mL), and di-t-butylsalicylaldehyde (10.00 g, 42.67 mmol) is added. The reaction mixture is stirred for three hours and then cooled to -25°C for 12 hours. The resulting yellow solid precipitate is collected by filtration and washed with cold methanol (2 x 15 mL), and then dried under reduced pressure. The yield is 11.17 g of a yellow solid. ¹H NMR is consistent with the desired product as a mixture of isomers.

b) Preparation of bis-(1-(2-methylcyclohexyl)ethyl)(2-oxoyl-3,5-di(t-butyl)phenyl) imino)zirconium dibenzyl

[0142] A solution of (1-(2-methylcyclohexyl)ethyl)(2-oxoyl-3,5-di(t-butyl)phenyl)imine (7.63 g, 23.2 mmol) in 200 mL toluene is slowly added to a solution of Zr(CH₂Ph)₄ (5.28 g, 11.6 mmol) in 600 mL toluene. The resulting dark yellow solution is stirred for 1 hour at 25°C. The solution is diluted further with 680 mL toluene to give a solution having a concentration of 0.00783 M.

[0143] Cocatalyst 1 A mixture of methyldi(C₁₄₋₁₈ alkyl)ammonium salts of tetrakis(pentafluorophenyl)borate (here-in-after armeenium borate), prepared by reaction of a long chain trialkylamine (Armeen™ M2HT, available from Akzo-Nobel, Inc.), HCl and Li[B(C₆F₅)₄], substantially as disclosed in USP 5,919,9883, Ex. 2.

[0144] Cocatalyst 2 Mixed C₁₄₋₁₈ alkyldimethylammonium salt of bis(tris(pentafluorophenyl)-alumane)-2-undecylimidazole, prepared according to USP 6.395.671, Ex. 16.

[0145] Shuttling Agents The shuttling agents employed include diethylzinc (DEZ., SA1), di(i-butyl)zinc (SA2), di(n-hexyl)zinc (SA3), triethylaluminum (TEA, SA4), trioctylaluminum (SA5), triethylgallium (SA6), i-butylaluminum bis(dimethyl(t-butyl)siloxane) (SA7), i-butylaluminum bis(di(trimethylsilyl)amide) (SA8), n-octylaluminum di(pyridine-2-methoxide) (SA9), bis(n-octadecyl)i-butylaluminum (SA10), i-butylaluminum bis(di(n-pentyl)amide) (SA11), n-octylaluminum bis(2,6-di-t-butylphenoxide) (SA12), n-octylaluminum di(ethyl)(1-naphthyl)amide (SA13), ethylaluminum bis(t-butylidimethylsiloxide) (SA14), ethylaluminum di(bis(trimethylsilyl)amide) (SA15), ethylaluminum bis(2,3,6,7-dibenzo-1-azacycloheptaneamide) (SA16), n-octylaluminum bis(2,3,6,7-dibenzo-1-azacycloheptaneamide) (SA17), n-octylaluminum bis(dimethyl(t-butyl)siloxide) (SA18), ethylzinc (2,6-diphenylphenoxide) (SA19), and ethylzinc (t-butoxide) (SA20).

Examples 1-4, Comparative A-C

General High Throughput Parallel Polymerization Conditions

[0146] Polymerizations are conducted using a high throughput, parallel polymerization reactor (PPR) available from

EP 2 102 396 B1

Symyx Technologies, Inc. and operated substantially according to US Patents No. 6,248,540, 6,030,917, 6,362,309, 6,306,658, and 6,316,663. Ethylene copolymerizations are conducted at 130°C and 200 psi (1.4 MPa) with ethylene on demand using 1.2 equivalents of cocatalyst I based on total catalyst used (1.1 equivalents when MMAO is present). A series of polymerizations are conducted in a parallel pressure reactor (PPR) contained of 48 individual reactor cells in a 6 x 8 array that are fitted with a preweighed glass tube. The working volume in each reactor cell is 6000 μ L. Each cell is temperature and pressure controlled with stirring provided by individual stirring paddles. The monomer gas and quench gas are plumbed directly into the PPR unit and controlled by automatic valves. Liquid reagents are robotically added to each reactor cell by syringes and the reservoir solvent is mixed alkanes. The order of addition is mixed alkanes solvent (4 ml), ethylene, 1-octene comonomer (1 ml), cocatalyst 1 or cocatalyst 1/MMAO mixture, shuttling agent, and catalyst or catalyst mixture. When a mixture of cocatalyst 1 and MMAO or a mixture of two catalysts is used, the reagents are premixed in a small vial immediately prior to addition to the reactor. When a reagent is omitted in an experiment, the above order of addition is otherwise maintained. Polymerizations are conducted for approximately 1-2 minutes, until predetermined ethylene consumptions are reached. After quenching with CO, the reactors are cooled and the glass tubes are unloaded. The tubes are transferred to a centrifuge/vacuum drying unit, and dried for 12 hours at 60°C. The tubes containing dried polymer are weighed and the difference between this weight and the tare weight gives the net yield of polymer. Results are contained in Table 1. In Table 1 and elsewhere in the application, comparative compounds are indicated by an asterisk (*).

[0147] Examples 1-4 demonstrate the synthesis of linear block copolymers by the present invention as evidenced by the formation of a very narrow MWD, essentially monomodal copolymer when DEZ is present and a bimodal, broad molecular weight distribution product (a mixture of separately produced polymers) in the absence of DEZ. Due to the fact that Catalyst (A1) is known to incorporate more octene than Catalyst (B1), the different blocks or segments of the resulting copolymers of the invention are distinguishable based on branching or density.

Table 1

Ex.	Cat. (A1) (μ mol)	Cat (B1) (μ mol)	Cocat (μ mol)	MMAO (μ mol)	shuttling agent (μ mol)	Yield (g)	Mn	Mw/Mn	hexyls ¹
A*	0.06	-	0.066	0.3	-	0.1363	300502	3.32	-
B*	-	0.1	0.110	0.5	-	0.1581	36957	1.22	2.5
C*	0.06	0.1	0.176	0.8	-	0.2038	45526	5.30 ²	5.5
1	0.06	0.1	0.192	-	DEZ (8.0)	0.1974	28715	1.19	4.8
2	0.06	0.1	0.192	-	DEZ (80.0)	0.1468	2161	1.12	14.4
3	0.06	0.1	0.192	-	TEA (8.0)	0.208	22675	1.71	4.6
4	0.06	0.1	0.192	-	TEA (80.0)	0.1879	3338	1.54	9.4

¹ C₆ or higher chain content per 1000 carbons

² Bimodal molecular weight distribution

[0148] It may be seen the polymers produced according to the invention have a relatively narrow polydispersity (Mw/Mn) and larger block-copolymer content (trimer, tetramer, or larger) than polymers prepared in the absence of the shuttling agent.

[0149] Further characterizing data for the polymers of Table I are determined by reference to the figures. More specifically DSC and ATREF results show the following:

[0150] The DSC curve for the polymer of example 1 shows a 115.7°C melting point (T_m) with a heat of fusion of 158.1 J/g. The corresponding CRYSTAF curve shows the tallest peak at 34.5°C with a peak area of 52.9 percent. The difference between the DSC T_m and the T_{crystaf} is 81.2°C.

[0151] The DSC curve for the polymer of example 2 shows a peak with a 109.7°C melting point (T_m) with a heat of fusion of 214.0 J/g. The corresponding CRYSTAF curve shows the tallest peak at 46.2°C with a peak area of 57.0 percent. The difference between the DSC T_m and the T_{crystaf} is 63.5°C.

[0152] The DSC curve for the polymer of example 3 shows a peak with a 120.7°C melting point (T_m) with a heat of fusion of 160.1 J/g. The corresponding CRYSTAF curve shows the tallest peak at 66.1°C with a peak area of 71.8 percent. The difference between the DSC T_m and the T_{crystaf} is 54.6°C.

[0153] The DSC curve for the polymer of example 4 shows a peak with a 104.5°C melting point (T_m) with a heat of fusion of 170.7 J/g. The corresponding CRYSTAF curve shows the tallest peak at 30 °C with a peak area of 18.2 percent. The difference between the DSC T_m and the T_{crystaf} is 74.5°C.

[0154] The DSC curve for comparative A shows a 90.0°C melting point (T_m) with a heat of fusion of 86.7 J/g. The corresponding CRYSTAF curve shows the tallest peak at 48.5°C with a peak area of 29.4 percent. Both of these values are consistent with a resin that is low in density. The difference between the DSC T_m and the T_{crystaf} is 41.8°C.

EP 2 102 396 B1

[0155] The DSC curve for comparative B shows a 129.8°C melting point (T_m) with a heat of fusion of 237.0 J/g. The corresponding CRYSTAF curve shows the tallest peak at 82.4°C with a peak area of 83.7 percent. Both of these values are consistent with a resin that is high in density. The difference between the DSC T_m and the $T_{crystaf}$ is 47.4°C.

5 [0156] The DSC curve for comparative C shows a 125.3°C melting point (T_m) with a heat of fusion of 143.0 J/g. The corresponding CRYSTAF curve shows the tallest peak at 81.8 °C with a peak area of 34.7 percent as well as a lower crystalline peak at 52.4 °C. The separation between the two peaks is consistent with the presence of a high crystalline and a low crystalline polymer. The difference between the DSC T_m and the $T_{crystaf}$ is 43.5°C.

Examples 5-19, Comparatives D-F, Continuous Solution Polymerization, Catalyst A1/B2 + DEZ

10 [0157] Continuous solution polymerizations are carried out in a computer controlled autoclave reactor equipped with an internal stirrer. Purified mixed alkanes solvent (Isopar™ E available from ExxonMobil Chemical Company), ethylene at 2.70 lbs/hour (1.22 kg/hour), 1-octene, and hydrogen (where used) are supplied to a 3.8 L reactor equipped with a jacket for temperature control and an internal thermocouple. The solvent feed to the reactor is measured by a mass-
15 flow controller. A variable speed diaphragm pump controls the solvent flow rate and pressure to the reactor. At the discharge of the pump, a side stream is taken to provide flush flows for the catalyst and cocatalyst 1 injection lines and the reactor agitator. These flows are measured by Micro-Motion mass flow meters and controlled by control valves or by the manual adjustment of needle valves. The remaining solvent is combined with 1-octene, ethylene, and hydrogen (where used) and fed to the reactor. A mass flow controller is used to deliver hydrogen to the reactor as needed. The
20 temperature of the solvent/monomer solution is controlled by use of a heat exchanger before entering the reactor. This stream enters the bottom of the reactor. The catalyst component solutions are metered using pumps and mass flow meters and are combined with the catalyst flush solvent and introduced into the bottom of the reactor. The reactor is run liquid-full at 500 psig (3.45 MPa) with vigorous stirring. Product is removed through exit lines at the top of the reactor. All exit lines from the reactor are steam traced and insulated. Polymerization is stopped by the addition of a small amount
25 of water into the exit line along with any stabilizers or other additives and passing the mixture through a static mixer. The product stream is then heated by passing through a heat exchanger before devolatilization. The polymer product is recovered by extrusion using a devolatilizing extruder and water cooled pelletizer. Process details and results are contained in Table 2. Selected polymer properties are provided in Table 3.

Table 2 Process details for preparation of exemplary polymers

Fx.	C ₈ H ₁₆ kg/hr	Solv. kg/hr	H ₂ seem ¹	T °C	Cat A1 ² ppm	Cat A1 Flow kg/hr	Cat B2 ³ ppm	B2 Flow kg/hr	DEZ Conc %	DEZ Flow kg/hr	Cocat Cunc. ppm	Cocat Flow kg/hr	[C ₂ H ₄]/ [DEZ] ⁴	Poly Rate ⁵ kg/hr	Conv % ⁶	Solids %	Eff. ⁷
D*	1.63	12.7	29.90	120	142.2	0.14	"	"	0.19	0.32	820	0.17	536	1.81	88.8	11.2	95.2
E*	"	9.5	5.00	"	"	"	109	0.10	0.19	"	1743	0.40	485	1.47	89.9	11.3	126.8
F*	"	11.3	251.6	"	71.7	0.06	30.8	0.06	"	"	"	0.11	"	1.55	88.5	10.3	257.7
5	"	"	"	"	"	0.14	30.8	0.13	0.17	0.43	"	0.26	419	1.64	89.6	11.1	118.3
6	"	"	4.92	"	"	0.10	30.4	0.08	0.17	0.32	"	0.18	570	1.65	89.3	11.1	172.7
7	"	"	21.70	"	"	0.07	30.8	0.06	0.17	0.25	"	0.13	718	1.60	89.2	10.6	244.1
8	"	"	36.90	"	"	0.06	"	"	"	0.10	"	0.12	1778	1.62	90.0	10.8	261.1
9	"	"	78.43	"	"	"	"	"	"	0.04	"	"	4596	1.63	90.2	10.8	267.9
10	"	"	0.00	123	71.1	0.12	30.3	0.14	0.34	0.19	1743	0.08	415	1.67	90.31	11.1	131.1
11	"	"	"	120	71.1	0.16	"	0.17	0.80	0.15	1743	0.10	249	1.68	89.56	11.1	100.6
12	"	"	"	121	71.1	0.15	"	0.07	"	0.09	1743	0.07	396	1.70	90.02	11.3	137.0
13	"	"	"	122	71.1	0.12	"	0.06	"	0.05	1743	0.05	653	1.69	89.64	11.2	161.9
14	"	"	"	120	71.1	0.05	"	0.29	"	0.10	1743	0.10	395	1.41	89.42	9.3	114.1
15	2.45	"	"	"	71.1	0.14	"	0.17	"	0.14	1743	0.09	282	1.80	89.33	11.3	121.3
16	"	"	"	122	71.1	0.10	"	0.13	"	0.07	1743	0.07	485	1.78	90.11	11.2	159.7
17	"	"	"	121	71.1	0.10	"	0.14	"	0.08	1743	"	506	1.75	89.08	11.0	155.6
18	0.69	"	"	121	71.1	"	"	0.22	"	0.11	1743	0.10	331	1.25	89.93	8.8	90.2
19	0.32	"	"	122	71.1	0.06	"	"	"	0.09	1743	0.08	367	1.16	90.74	8.4	106.0

*Comparative, not an example of the invention
¹ standard cm³/min
² [N-(2,6-di(1-methylethyl)phenyl)amido)(2-isopropylphenyl)(α -naphthalen-2-diyl(6-pyridin-2-diyl)methane)]hafnium dimethyl
³ bis-(1-(2-methylcyclohexyl)ethyl)(2-oxoyl-3,5-di(t-butyl)immino)zirconium dibenzyl
⁴ molar ratio in reactor
⁵ polymer production rate
⁶ percent ethylene conversion in reactor
⁷ efficiency, kg polymer/g M where g M =g Hf + g Zr

Table 3 Properties of exemplary polymers

Ex.	Density (g/cm ³)	<i>I</i> ₂	<i>I</i> ₁₀	<i>I</i> ₁₀ / <i>I</i> ₂	Mw (g/mol)	Mn (g/mol)	Mw/Mn	Heat of Fusion (J/g)	T _m (°C)	T _c (C°)	T _{CRYSTAF} (°C)	T _{m-CRYSTAF} T (°C)	CRYSTAF Peak Area (percent)
D*	0.8627	1.5	10.0	6.5	110,000	55,800	2.0	32	37	45	30	7	99
E*	0.9378	7.0	39.0	5.6	65,000	33,300	2.0	183	124	113	79	45	95
F*	0.8895	0.9	12.5	13.4	137,300	9,980	13.8	90	125	111	78	47	20
5	0.8786	1.5	9.8	6.7	104,600	53,200	2.0	55	120	101	48	72	60
6	0.8785	1.1	7.5	6.5	109600	53300	2.1	55	115	94	44	71	63
7	0.8825	1.0	7.2	7.1	118,500	53,100	2.2	69	121	103	49	72	29
8	0.8828	0.9	6.8	7.7	129,000	40,100	3.2	68	124	106	80	43	13
9	0.8836	1.1	9.7	9.1	129600	28700	4.5	74	125	109	81	44	16
10	0.8784	1.2	7.5	6.5	113,100	58,200	1.9	54	116	92	41	75	52
11	0.8818	9.1	59.2	6.5	66,200	36,500	1.8	63	114	93	40	74	25
12	0.8700	2.1	13.2	6.4	101,500	55,100	1.8	40	113	80	30	83	91
13	0.8718	0.7	4.4	6.5	132,100	63,600	2.1	42	114	80	30	81	8
14	0.9116	2.6	15.6	6.0	81,900	43,600	1.9	123	121	106	73	48	92
15	U.8719	6.0	41.6	6.9	79,900	40,100	2.0	33	114	91	32	82	10
16	0.8758	0.5	3.4	7.1	148,500	74,900	2.0	43	117	96	48	69	65
17	0.8757	1.7	11.3	6.8	107,500	54,000	2.0	43	116	96	43	73	57
18	0.9192	4.1	24.9	6.1	72,000	37,900	1.9	136	120	106	70	50	94
19	0.9344	3.4	20.3	6.0	76,800	39,400	1.9	169	125	112	80	45	88

EP 2 102 396 B1

[0158] The resulting polymers are tested by DSC and ATREF as with previous examples. Results are as follows:

[0159] The DSC curve for the polymer of example 5 shows a peak with a 119.6 °C melting point (T_m) with a heat of fusion of 60.0 J/g. The corresponding CRYSTAF curve shows the tallest peak at 47.6°C with a peak area of 59.5 percent. The delta between the DSC T_m and the T_{crystaf} is 72.0°C.

[0160] The DSC curve for the polymer of example 6 shows a peak with a 115.2 °C melting point (T_m) with a heat of fusion of 60.4 J/g. The corresponding CRYSTAF curve shows the tallest peak at 44.2°C with a peak area of 62.7 percent. The delta between the DSC T_m and the T_{crystaf} is 71.0°C.

[0161] The DSC curve for the polymer of example 7 shows a peak with a 121.3 °C melting point with a heat of fusion of 69.1 J/g. The corresponding CRYSTAF curve shows the tallest peak at 49.2°C with a peak area of 29.4 percent. The delta between the DSC T_m and the T_{crystaf} is 72.1 °C.

[0162] The DSC curve for the polymer of example 8 shows a peak with a 123.5 °C melting point (T_m) with a heat of fusion of 67.9 J/g. The corresponding CRYSTAF curve shows the tallest peak at 80.1°C with a peak area of 12.7 percent. The delta between the DSC T_m and the T_{crystaf} is 43.4°C.

[0163] The DSC curve for the polymer of example 9 shows a peak with a 124.6 °C melting point (T_m) with a heat of fusion of 73.5 J/g. The corresponding CRYSTAF curve shows the tallest peak at 80.8°C with a peak area of 16.0 percent. The delta between the DSC T_m and the T_{crystaf} is 43.8°C.

[0164] The DSC curve for the polymer of example 10 shows a peak with a 115.6 °C melting point (T_m) with a heat of fusion of 60.7 J/g. The corresponding CRYSTAF curve shows the tallest peak at 40.9°C with a peak area of 52.4 percent. The delta between the DSC T_m and the T_{crystaf} is 74.7°C.

[0165] The DSC curve for the polymer of example 11 shows a peak with a 113.6 °C melting point (T_m) with a heat of fusion of 70.4 J/g. The corresponding CRYSTAF curve shows the tallest peak at 39.6°C with a peak area of 25.2 percent. The delta between the DSC T_m and the T_{crystaf} is 74.1°C.

[0166] The DSC curve for the polymer of example 12 shows a peak with a 113.2 °C melting point (T_m) with a heat of fusion of 48.9 J/g. The corresponding CRYSTAF curve shows no peak equal to or above 30°C. (T_{crystaf} for purposes of further calculation is therefore set at 30°C). The delta between the DSC T_m and the T_{crystaf} is 83.2°C.

[0167] The DSC curve for the polymer of example 13 shows a peak with a 114.4°C melting point (T_m) with a heat of fusion of 49.4 J/g. The corresponding CRYSTAF curve shows the tallest peak at 33.8 °C with a peak area of 7.7 percent. The delta between the DSC T_m and the T_{crystaf} is 84.4°C.

[0168] The DSC for the polymer of example 14 shows a peak with a 120.8 °C melting point (T_m) with a heat of fusion of 1.27.9 J/g. The corresponding CRYSTAF curve shows the tallest peak at 72.9 °C with a peak area of 92.2 percent. The delta between the DSC T_m and the T_{crystaf} is 47.9°C.

[0169] The DSC curve for the polymer of examples 15 shows a peak with a 114.3 °C melting point (T_m) with a heat of fusion of 36.2 J/g, The corresponding CRYSTAF curve shows the tallest peak at 32.3 °C with a peak area of 9.8 percent. The delta between the DSC T_m and the T_{crystaf} is 82.0°C.

[0170] The DSC curve for the polymer of example 16 shows a peak with a 116.6 °C melting point (T_m) with a heat of fusion of 44.9 J/g. The corresponding CRYSTAF curve shows the tallest peak at 48.0 °C with a peak area of 65.0 percent, the delta between the DSC T_m and the T_{crystaf} is 68.6°C.

[0171] The DSC curve for the polymer of example 17 shows a peak with a 116.0 °C melting point (T_m) with a heat of fusion of 47.0 J/g. The corresponding CRYSTAF curve shows the tallest peak at 43.1 °C with a peak area of 56.8 percent. The delta between the DSC T_m and the T_{crystaf} is 72.9°C.

[0172] The DSC curve for the polymer of example 18 shows a peak with a 120.5 °C melting point (T_m) with a heat of fusion of 141.8 J/g. The corresponding CRYSTAF curve shows the tallest peak at 70.0 °C with a peak area of 94.0 percent. The delta between the DSC T_m and the T_{crystaf} is 50.5 °C.

[0173] The DSC curve for the polymer of example 19 shows a peak with a 124.8 °C melting point (T_m) with a heat of fusion of 174.8 J/g. The corresponding CRYSTAF curve shows the tallest peak at 79.9 °C with a peak area of 87.9 percent. The delta between the DSC T_m and the T_{crystaf} is 45.0 °C.

[0174] The DSC curve for the polymer of comparative D shows a peak with a 37.3°C melting point (T_m) with a heat of fusion of 31.6 J/g. The corresponding CRYSTAF curve shows no peak equal to and above 30°C. Both of these values are consistent with a resin that is low in density. The delta between the DSC T_m and the T_{crystaf} is 7.3°C.

[0175] The DSC curve for the polymer of comparative E shows a peak with a 124.0 °C melting point (T_m) with a heat of fusion of 179.3 J/g. The corresponding CRYSTAF curve shows the tallest peak at 79.3°C with a peak area of 94.6 percent. Both of these values are consistent with a resin that is high in density. The delta between the DSC T_m and the T_{crystaf} is 44.6°C.

[0176] The DSC curve for the polymer of comparative F shows a peak with a 124.8 °C melting point (T_m) with a heat of fusion of 90.4 J/g. The corresponding CRYSTAF curve shows the tallest peak at 77.6°C with a peak area of 19.5 percent. The separation between the two peaks is consistent with the presence of both a high crystalline and a low crystalline polymer. The delta between the DSC T_m and the T_{crystaf} is 47.2°C.

Physical Property Testing

[0177] Polymer samples are evaluated for physical properties such as high temperature resistance properties, as evidenced by TMA temperature testing, pellet blocking strength, high temperature recovery, high temperature compression set and storage modulus ratio, $G'(25^{\circ}\text{C})/G'(100^{\circ}\text{C})$. Several commercially available polymers are included in the tests: Comparative G* is a substantially linear ethylene/1-octene copolymer (AFFINITY®, available from The Dow Chemical Company), Comparative H* is an elastomeric, substantially linear ethylene/1-octene copolymer (AFFINITY®EG8100, available from The Dow Chemical Company), Comparative I is a substantially linear ethylene/1-octene copolymer (AFFINITY®PL 1840, available from The Dow Chemical Company), Comparative J is a hydrogenated styrene/butadiene/styrene triblock copolymer (KRATON™ G1652, available from KRATON Polymer). Comparative K is a thermoplastic vulcanizate (TPV, a polyolefin blend containing dispersed therein a crosslinked elastomer). Results are presented in Table 4.

Table 4 High Temperature Mechanical Properties

Ex.	TMA-1mm penetration ($^{\circ}\text{C}$)	Pellet Blocking Strength, lb/ft ² (kPa)	$G'(25^{\circ}\text{C})/G'(100^{\circ}\text{C})$	300 % Strain Recovery (80°C) (percent)	Compression Set (70°C) (percent)
D*	51	-	9	Failed	-
E*	130	-	18	-	-
F*	70	141 (6.8)	9.	Failed	100
5	104	0 (0)	6 81		49
6	110	-	5	-	52
7	113	-	4	84	43
8	111	-	4	Failed	41
9	97	-	4	-	66
10	108	-	5	81	55
11	10	-	8	-	68
12	88	-	8	-	79
13	95	-	6	84	71
14	125	-	7	-	-
15	96	-	5	-	58
16	113	-	4	-	42
17	108	0(0)	4	82	47
18	125	-	10	-	-
19	133	-	9	-	-
G*	75	463(22.2)	89	Failed	100
H*	70	213 (10.2)	29	Failed	100
I*	111	-	1.1	-	-
J*	107	-	5	Failed	100
K*	152	-	3	-	40

[0178] In Table 4, Comparative F (which is a physical blend of the two polymers resulting from simultaneous polymerizations using catalyst A1 and B1 has a 1 mm penetration temperature of about 70°C , while Examples 5-9 have a 1 mm penetration temperature of 100°C or greater. Further, examples 10-19 all have a 1 mm penetration temperature of greater than 85°C , with most having 1 mm TMA temperature of greater than 90°C or even greater than 100°C . This shows that the novel polymers have better dimensional stability at higher temperatures compared to a physical blend. Comparative J (a commercial SEBS) has a good 1 mm TMA temperature of about 107°C , but it has very poor (high

EP 2 102 396 B1

temperature 70°) compression set of about 100 percent and it also failed to recover (sample broke) during a high temperature (80°C) 300 percent strain recovery. Thus the exemplified polymers have a unique combination of properties unavailable even in some commercially available, high performance thermoplastic elastomers.

5 [0179] Similarly, Table 4 shows a low (good) storage modulus ratio, $G'(25^{\circ}\text{C})/G'(100^{\circ}\text{C})$, for the inventive polymers of 6 or less, whereas a physical blend (Comparative F) has a storage modulus ratio of 9 and a random ethylene/octene copolymer (Comparative G) of similar density has a storage modulus ratio an order of magnitude greater (89). It is desirable that the storage modulus ratio of a polymer be as close to 1 as possible. Such polymers will be relatively unaffected by temperature, and fabricated articles made from such polymers can be usefully employed over a broad temperature range. This feature of low storage modulus ratio and temperature independence is particularly useful in
10 elastomer applications such as in pressure sensitive adhesive formulations.

[0180] The data in Table 4 also demonstrate that the polymers of the invention possess improved pellet blocking strength. In particular, Examples 5 has a pellet blocking strength of 0 MPa, meaning it is free flowing under the conditions tested, compared to Comparatives F and G which show considerable blocking. Blocking strength is important since bulk shipment of polymers having large blocking strengths can result in product clumping or sticking together upon storage
15 or shipping, resulting in poor handling properties.

[0181] High temperature (70°C) compression set for the inventive polymers is generally good, meaning generally less than 80 percent, preferably less than 70 percent and especially less than 60 percent. In contrast, Comparatives F, G, H and J all have a 70°C compression set of 100 percent (the maximum possible value, indicating no recovery). Good high temperature compression set (low numerical values) is especially needed for applications such as gaskets, window
20 profiles, o-rings, and the like.

25

30

35

40

45

50

55

Table 5 Ambient Temperature Mechanical Properties

Ex .	flex Mod ulUS (MPa)	Tensile Modulus (MPa)	Tensile Strengt h (MPa) ¹	Elongation at Break ¹ (%)	Tensile Strength (MPa)	Elongation at Break (%) 1074	Abrasion: Volume Loss (mm ³)	Tensile Notched Tear Strength (mJ)	100% Strain Recovery 21°C (percent)	300 % Strain Recovery 21°C (percent)	Retractive Stress at 150 % Strain (kPa)	Compression Set 21°C (Percent)	Stress Relaxation at 50% Strain
D *	12	5	-	-	10	1074	-	-	91	83	760	-	-
F *	895	589	-	-	31	1029	-	-	-	-	-	-	-
R *	57	46	-	-	12	824	93	339	78	65	400	42	-
5	30	24	14	951	16	1116	48		87	74	790	14	33
6	33	29	-	-	14	938	-	-		75	861	13	-
7	44	37	15	846	14	854	39		82	73	810	20	-
8	41	35	13	785	14	810	45	461	82	74	760	22	-
9	43	38	-	-	12	823	-	-	-	-	-	25	-
10	23	23	-	-	14	902	-	-	86	75	860	12	-
11	30	26	-	-	16	1090	-	976	89	66	510	14	30
12	20	17	-	961	13	931	-	1247	91	75	700	17	-
13	16	14	-	-	13	814	-	691	91	-	-	21	-
14	212	160	-	-	29	857	-	-	-	-	-	-	-
15	18	14	12	1127	10	1573	-	2074	89	83	770	14	-
16	23	20	-	-	12	968	-	-	88	83	1040	13	-

(continued)

Ex.	flex Modulus (MPa)	Tensile Modulus (MPa)	Tensile Strength (MPa) ¹	Elongation at Break ¹ (%)	Tensile Strength (MPa)	Elongation at Break (%) 1074	Abrasion: Volume Loss (mm ³)	Tensile Notched Tear Strength (mJ)	100% Strain Recovery 21°C (percent)	300 % Strain Recovery 21°C (percent)	Retractive Stress at 150 % Strain (kPa)	Compression Set 21°C (Percent)	Stress Relaxation at 50% Strain
17	20	18	-	-	13	1252	-	1274	13	83	920	4	-
18	323	239	-	-	30	808	-	-	-	-	-	-	-
19	706	483	-	-	36	871	-	-	-	-	-	-	-
G*	15	15	-	-	17	1000	-	746	86	53	110	27	50
H*	16	15	-	-	15	829	-	569	87	60	380	23	-
I*	21	147	-	-	29	697	-	-	-	-	-	-	-
J*	-	-	-	-	32	609	-	-	93	96	1900	25	-
K*	-	-	-	-	-	-	-	-	-	-	-	30	-
¹ Tested at 51 cm/minute ² measured at 38°C for 12 hours													

EP 2 102 396 B1

[0182] Table 5 shows results for mechanical properties for the new polymers as well as for various comparison polymers at ambient temperatures. It may be seen that the inventive polymers have very good abrasion resistance when tested according to ISO 4649, generally showing a volume loss of less than 90 mm³, preferably less than 80 mm³, and especially less than 50 mm³. In this test, higher numbers indicate higher volume loss and consequently lower abrasion resistance.

[0183] Tear strength as measured by tensile notched tear strength of the inventive polymers is generally 1000 mJ or higher, as shown in Table 5. Tear strength for the inventive polymers can be as high as 3000 mJ, or even as high as 5000 mJ. Comparative polymers generally have tear strengths no higher than 750 mJ.

[0184] Table 5 also shows that the polymers of the invention have better retractive stress at 150 percent strain (demonstrated by higher retractive stress values) than some of the comparative samples. Comparative Examples F, G and H have retractive stress value at 150 percent strain of 400 kPa or less, while the inventive polymers have retractive stress values at 150 percent strain of 500 kPa (Ex. 11) to as high as about 1100 kPa (Ex. 17). Polymers having higher than 150 percent retractive stress values would be quite useful for elastic applications, such as elastic fibers and fabrics, especially nonwoven fabrics. Other applications include diaper, hygiene, and medical garment waistband applications, such as tabs and elastic bands.

[0185] Table 5 also shows that stress relaxation (at 50 percent strain) is also improved (less) for the inventive polymers as compared to, for example, Comparative G. Lower stress relaxation means that the polymer retains its force better in applications such as diapers and other garments where retention of elastic properties over long time periods at body temperatures is desired.

Optical Testing

[0186]

Table 6 Polymer Optical Properties

Ex.	Internal Haze (percent)	Clarity (percent)	45° Gloss (percent)
F*	84	22	49
G*	5	73	56
5	13	72	60
6	33	69	53
7	28	57	59
8	20	65	62
9	61	38	49
10	15	73	67
11	13	69	67
12	8	75	72
13	7	74	69
14	59	15	62
15	11	74	66
16	39	70	65
17	29	73	66
18	61	22	60
19	74	11	52
G*	5	73	56
H*	12	76	59
I*	20	75	59

[0187] The optical properties reported in Table 6 are based on compression molded films substantially lacking in orientation. Optical properties of the polymers may be varied over wide ranges, due to variation in crystallite size, resulting

from variation in the quantity of chain shuttling agent employed in the polymerization.

Extractions of Multi-Block Copolymers

5 **[0188]** Extraction studies of the polymers of examples 5, 7 and Comparative E are conducted. In the experiments, the polymer sample is weighed into a glass fritted extraction thimble and fitted into a Kumagawa type extractor. The extractor with sample is purged with nitrogen, and a 500mL round bottom flask is charged with 350 mL of diethyl ether. The flask is then fitted to the extractor. The ether is heated while being stirred. Time is noted when the ether begins to condense into the thimble, and the extraction is allowed to proceed under nitrogen for 24 hours. At this time, heating is stopped and the solution is allowed to cool. Any ether remaining in the extractor is returned to the flask. The ether in the flask is evaporated under vacuum at ambient temperature, and the resulting solids are purged dry with nitrogen. Any residue is transferred to a weighed bottle using successive washes of hexane. The combined hexane washes are then evaporated with another nitrogen purge, and the residue dried under vacuum overnight at 40°C. Any remaining ether in the extractor is purged dry with nitrogen.

10
15 **[0189]** A second clean round bottom flask charged with 350 mL of hexane is then connected to the extractor. The hexane is heated to reflux with stirring and maintained at reflux for 24 hours after hexane is first noticed condensing into the thimble. Heating is then stopped and the flask is allowed to cool. Any hexane remaining in the extractor is transferred back to the flask. The hexane is removed by, evaporation under vacuum at ambient temperature, and any residue remaining in the flask is transferred to a weighed bottle using successive hexane washes. The hexane in the flask is evaporated by a nitrogen purge, and the residue is vacuum dried overnight at 40°C.

20 **[0190]** The polymer sample remaining in the thimble after the extractions is transferred from the thimble to a weighed bottle and vacuum dried overnight at 40°C. Results are contained in Table 7.

25

30

35

40

45

50

55

Table 7

Sample	wt. (g)	ether soluble (g)	ether soluble (percent)	C ₈ mole percent ¹	hexane soluble (g)	hexane soluble (percent)	C ₈ mole percent ¹	residue C ₈ mole percent ¹
Comp. F*	1.097	0.063	5.69	12.2	0.245	22.35	13.6	6.5
Ex. 5	1.006	0.041	4.08	-	0.040	3.98	14.2	11.6
Ex.7	1.092	0.017	1.59	13.3	0.012	1,10	11.7	9.9
Determined by ¹³ C NMR								

Additional Polymer Examples 19 A-J, Continuous Solution Polymerization, Catalyst A1/B2 + DEZ

For Examples 19 A-1.

5 **[0191]** Continuous solution polymerizations are carried out in a computer controlled well-mixed reactor. Purified mixed
alkanes solvent (Isopar™ E available from Exxon Mobil, Inc.), ethylene, 1-octene, and hydrogen (where used) are
combined and fed to a 27 galleon reactor. The feeds to the reactor are measured by mass-flow controllers. The tem-
perature of the feed stream is controlled by use of a glycol cooled heat exchanger before entering the reactor. The
10 catalyst component solutions are metered using pumps and mass flow meters. The reactor is run liquid-full at approxi-
mately 550 psig pressure. Upon exiting the reactor, water and additive are injected in the polymer solution. The water
hydrolyzes the catalysts, and terminates the polymerization reactions. The post reactor solution is then heated in prep-
aration for a two-stage devolatilization. The solvent and unreacted monomers are removed during the devolatilization
process. The polymer melt is pumped to a die for underwater pellet cutting.

15 For Example 19J

[0192] Continuous solution polymerizations are carried out in a computer controlled autoclave reactor equipped with
an internal stirrer. Purified mixed alkanes solvent (Tsopar™ E available from ExxonMobil Chemical Company), ethylene
at 2.70 lbs/hour (1.22 kg/hour), 1-octene, and hydrogen (where used) are supplied to a 3.8 L reactor equipped with a
20 jacket for temperature control and an internal thermocouple. The solvent feed to the reactor is measured by a mass-
flow controller. A variable speed diaphragm pump controls the solvent flow rate and pressure to the reactor. At the
discharge of the pump, a side stream is taken to provide flush flows for the catalyst and cocatalyst injection lines and
the reactor agitator. These flows are measured by Micro-Motion mass flow meters and controlled by control valves or
by the manual adjustment of needle valves. The remaining solvent is combined with 1-octene, ethylene, and hydrogen
25 (where used) and fed to the reactor. A mass flow controller is used to deliver hydrogen to the reactor as needed. The
temperature of the solvent/monomer solution is controlled by use of a heat exchanger before entering the reactor. This
stream enters the bottom of the reactor. The catalyst component solutions are metered using pumps and mass flow
meters and are combined with the catalyst flush solvent and introduced into the bottom of the reactor. The reactor is
run liquid-full at 500 psig (3.45 MPa) with vigorous stirring. Product is removed through exit lines at the top of the reactor.
30 All exit lines from the reactor are steam traced and insulated. Polymerization is stopped by the addition of a small amount
of water into the exit line along with any stabilizers or other additives and passing the mixture through a static mixer.
The product stream is then heated by passing through a heat exchanger before devolatilization. The polymer product
is recovered by extrusion using a devolatilizing extruder and water cooled pelletizer.

[0193] Process details and results are contained in Table 8. Selected polymer properties are provided in Tables 9A-C.

35 **[0194]** In Table 9B, inventive examples 19F and 19G show low immediate set of around 65 - 70 % strain after 500%
elongation.

40

45

50

55

55 50 45 40 35 30 25 20 15 10 5

Table 8 Polymerization Conditions

E x.	C ₂ H ₄ r lh/hr	C ₈ H ₁₆ lb/hr	Solv. lb/hr	H ₂ sccm 1	T °C	Cat		Cal	Cat			Coca	Coca	Coca	Coca	Zn ¹	Poly Rate ⁵ lb/br	Co n wt %	Polyme r wt%	Ef f.
						Al ² Con c. ppm	Cat A1 Flo w lh/h r	B2 ⁴ Con c. ppm	B2 Flo w lh/h r	DEZ Con e Wt%	DE Z Flo w lb/h r	t 1 Con c. ppm	t 1 Flow lb/hr	t 2 Con c. ppm	t 2 Flow lb/hr	in polyme r ppm				
1 9 A	55. 29	32.0 3	323.0 3	101	12 0	600	0.25	200	0.42	3.0	0.70	4500	0.65	525	0.33	248	83.9 4	88. 0	17.28	29 7
1 9 B	53. 95	28.9 6	325.3	577	12 0	600	0.25	200	0.55	3.0	0.24	4500	0.63	525	0.11	90	80.7 2	88. 1	17.2	29 5
1 9 C	55. 53	30.9 7	324 37	550	12 0	600	0.21 6	200	0.60 9	3.0	0.69	4500	0.61	525	0.33	246	84.1 3	88. 9	17.16	29 3
1 9 D	54. 83	30.5 8	326.3 3	60	12 0	600	0.22	200	0.63	3.0	1.39	4500	0.66	525	0.66	491	82.5 6	88. 1	17.07	28 0
1 9 E	54. 95	31.7 3	326.7 5	251	12 0	600	0.21	200	0.61	3.0	1.04	4500	0.64	525	0.49	368	84.1 1	88. 4	17.43	28 8
1 9 F	50. 43	34.8 0	330.3 3	124	12 0	600	0.20	200	0.60	3.0	0.74	4500	0.52	525	0.35	257	85.3 1	87. 5	17.09	31 9
1 9 G	50. 25	33.0 8	325.6 1	188	12 0	600	0.19	200	0.59	3.0	0.54	4500	0.51	525	0.16	194	83.7 2	87. 5	17.34	33 3
1 9 H	50. 15	34.8 7	318.1 7	58	12 0	600	0.21	200	0.66	3.0	0.70	4500	0.52	525	0.70	259	83.2 1	88. 0	17.46	31 2
1 9 1	55. 02	34.0 2	323.5 9	53	12 0	600	0.44	200	0.74	3.0	1.72	4500	0.70	525	0.65	600	86.6 3	88. 0	17.6	27 5

55 50 45 40 35 30 25 20 15 10 5

(continued)

E x.	C ₂ H ₄ l/h	C ₈ H ₁₆ l/h	Solv. l/h	H ₂ sccm	T °C	Cat	Cal	Cat	DEZ Wt%	DEZ l/h	Coca	Coca	Coca	Coca	Zn ¹	Poly Rate ⁵ l/br	Co n wt %	Polyme r wt%	Ef f.
						Al ² Con c. ppm	Cat A1 Flo w l/h	B2 ⁴ Con c. ppm			B2 Flo w l/h	1 Con c. ppm	1 Flow l/h	2 Con c. ppm	2 Flow l/h				
1																			
9	7.4				12														
J	6	9.04	50.6	47	0	150	0.22	76.7	0.36	0.5	0.19	-	-	-	-	-	-	-	-

¹ standard cm/min

² [N-(2,6-di(1-methylethyl)phenyl)amido]2-isopropylphenyl(α-naphthalen-2-diyl(6-pyridin-2-diyl)methane)]hafnium dimethyl

³ bis-(1-(2-methylcyclohexyl)ethyl)(2-oxoyl-3,5-di(t-butyl)phenyl)immino zirconium dimethyl

⁴ ppm in final product calculated by mass balance

⁵ polymer production rate

weight percent ethylene conversion in reactor

⁷ efficiency, kg polymer/g M where g M = gIlf + g Z

Table 9A Polymer Physical Properties

Ex.	Density (g/cc)	12	110	110/12	Mw (g/mol)	Mn (g/mol)	Mw/Mn	Heat of Fusion (J/g)	Tm (°C)	Tc (°C)	TCRYSTAF (°C)	Tm-CRYSTAF (°C)	CRYSTAF Peak Area (wt%)
19A	0.8781	0.9	6.4	6.9	123700	61000	2.0	56	119	97	46	73	40
19B	0.8749	0.9	7.3	7.8	133000	44300	3.0	52	122	100	30	92	76
19C	0.8753	5.6	38.5	6.9	81700	37300	2.2	46	122	100	30	92	8
19D	0.8770	4.7	31.5	6.7	80700	39700	2.0	52	119	97	48	72	5
19E	0.8750	4.9	33.5	6.8	81800	41700	2.0	49	121	97	36	84	12
19F	0.8652	1.1	7.5	6.8	124900	60700	2.1	27	119	88	30	89	89
19G	0.8649	0.9	6.4	7.1	135000	64800	2.1	26	120	92	30	90	90
19H	0.8654	1.0	7.0	7.1	131600	66900	2.0	26	118	88	-	-	-
19I	0.8774	11.2	75.2	6.7	66400	33700	2.0	49	119	99	40	79	13
19J	0.8995	5.6	39.4	7.0	75500	29900	2.5	101	122	106	-	-	-

55 50 45 40 35 30 25 20 15 10 5

Table 9B Polymer Physical Properties of Compression Molded Film

Example	Density (g/cm³)	Melt Index (g/10 min)	Immediate Set after 100% Strain (%)	Immediate Set after 300% Strain (%)	Immediate Set after 500% Strain (%)	Recovery after 100% (%)	Recovery after 300% (%)	Recovery after 500% (%)
19A	0.878	0.9	15	63	131	85	79	74
19B	0.877	0.88	14	49	97	86	84	81
19F	0.865	1	-	-	70	-	87	86
19G	0.865	0.9	-	-	66	-	-	87
19H	0.865	0.92	-	39	-	-	87	-

Table 9C Average Block Index For exemplary polymers¹

Example	Zn/C ₂ ²	Average BI
Polymer F	0	0
Polymer 8	0.56	0.59
Polymer 19a	1.3	0.62
Polymer 5	2.4	0.52
Polymer 19b	0.56	0.54
Polymer 19h	3.15	0.59

1. Additional information regarding the calculation of the block indices for various polymers is disclosed in U.S. Patent Application Serial No. 11/376,835, entitled "Ethylene/ α -Olefin Block Interpolymers", filed on March 15, 2006, in the name of Colin L.P. Shan, Lonnie Hazlitt, et. al. and assigned to Dow Global Technologies Inc., the disclosure of which is incorporated by reference herein in its entirety.

2. $Zn/C_2 \cdot 1000 = (Zn \text{ feed flow Zn concentration} / 1000000 / Mw \text{ of Zn} (Total \text{ Ethylene feed flow } * (1 - \text{fractional ethylene conversion rate}) / Mw \text{ of Ethylene}) * 1000$. Please more that Zn in $Zn/C_2 * 1000$ " refers to the amount of zinc in diethyl zinc (DEZ) used in the polymerization process, and "C2" refers to the amount of ethylene used in the polymerization process.

Examples 20 and 21

[0195] The ethylene/ α -olefin interpolymer of Examples 20 and 21 were made in a substantially similar manner as Examples 19A-1 above with the polymerization conditions shown in Table 11 below. The polymers exhibited the properties shown in Table 10. Table 10 also shows any additives to the polymer.

Table 10- Properties and Additives of Examples 20-21

	Example 20	Example 21
Density (g/cc)	0.8800	0.8800
MI	1.3	1.3
Additives	DI Water 100 Irgafos 168 1000 Irganox 1076 250 Irganox 1010 200 Chimmasorb 2020 100	DI Water 75 Irgafos 168 1000 Irganox 1076 250 Irganox 1010 200 Chimmasorb 2020 80
Hard segment split (wt%)	35%	35%

[0196] Irganox 1010 is Tetrakis(methylene (3,5-di-*t*-butyl-4-hydroxyhydrocinnamate)methane. Irganox 1076 is Octadecyl-3-(3',5'-di-*t*-butyl-4'-hydroxyphenyl)propionate. Irgafos 168 is Tris(2,4-di-*t*-butylphenyl)phosphite. Chimmasorb 2020 is 1,6-Hexanediamine. N,N'-bis(2,2,6,6-tetramethyl-4-piperidiny)-polymer with 2,3,6-trichloro-1,3,3-triazine, reaction products with, N-butyl-1-butanamine and N-butyl-2,2,6,6-tetramethyl-4-piperidinamine.

Table 11 - Polymerization Conditions for Examples 20-21

Ex.	C ₂ H ₄ lb/hr	C ₈ H ₁₆ lb/hr	Solv. lb/hr	H ₂ scm ¹	T °C	Cat Al ² Conc. ppm	Cat Al Flow lb/hr	Cat B2 ³ Conc. ppm	Cat B2 Flow lb/hr	DEZ Conc. wt%	DEZ Flow lb/hr	Cocat 1 Conc. ppm	Cocat I Flow lb/hr	Cocat 2 Conc. ppm	Cocat 2 Flow lb/hr	Zn ⁴ in polymer ppm	Poly Rate ⁵ lb/hr	Conv ⁶ wt%	Polyme r wt%	Eff. ⁷
20	130.7	196.17	712.68	176.7	120	499.98	1.06	298.89	0.57	4.809423	0.48	5634.36	1.24	402.45	0.478	131	177	89.25	16.64	252.04
21	132.13	199.22	708.23	157.2	120	462.4	1.71	298.89	0.6	4.999847	0.47	5706.4	1.61	289.14	1.36	129	183	89.23	17.52	188.11

⁰Comparative not an example of the invention
¹ standard cm³/min
² [N-(2,6-di(1-methylethyl)phenyl)amido)(2-isopropylphenyl)(α -naphthalen-2-diyl(6-pyridin-2-diyl)methane)]hafnium dimethyl
³ bis-(1-(2-methylcyclohexyl)ethyl)(2-oxoyl-3,5-di(t-butyl)phenyl)inunino zirconium dibenzyl
⁴ ppm Zinc in final product calculated by mass balance
⁵ polymer production rate
⁶ weight percent ethylene conversion in reactor
⁷ efficiency, kg polymer/g M where M-g Hf+gZ

Fibers Suitable for the Dyed Fabrics and Textile Articles of the Present Invention

[0197] The present invention relates to dyed fabrics suitable for textile articles such as shirts, pants, socks, swimsuits, etc. The fabrics may be made in any manner but typically are either woven or knit. Woven fabrics of the present invention are typically characterized by a stretch of at least 10 percent measured according to ASTM D3107 whereas knit fabrics of the present invention are typically characterized by a stretch of at least 30 percent measured according to ASTM D2594.

[0198] The dyed fabrics are usually comprised of one or more elastic fibers wherein the elastic fibers comprise the reaction product of at least one ethylene olefin block polymer and at least one suitable crosslinking agent. As used herein, "crosslinking agent" is any means which cross-links one or more, preferably, a majority, of the fibers. Thus, crosslinking agents may be chemical compounds but are not necessarily so. Crosslinking agents as used herein also include electron-beam irradiation, beta irradiation gamma irradiation, corona irradiation, silanes, peroxides, allyl compounds and UV radiation with or without crosslinking catalyst. U.S. Patents No. 6,803,014 and 6,667,31 disclose electron-beam irradiation methods that can be used in embodiments of the invention. Typically, enough fibers are crosslinked in an amount such that the fabric is capable of being dyed. This amount varies depending upon the specific polymer employed and the desired properties. In particular, the percent of cross-linked polymer can be at least 5 percent, preferably at least 10, more preferably at least 15 weight percent to at most 75, preferably at most 65, preferably at most 50 percent, more preferably at most 40 percent as measured by the weight percent of gels formed according to the method described in Example 25.

[0199] The fibers typically have a filament elongation to break of greater than 200%, preferably greater than 210%, preferably greater than 220%, preferably greater than 230%, preferably greater than 240%, preferably greater than 250%, preferably greater than 260%, preferably greater than 270%, preferably greater than 280%, and may be as high as 600% according to ASTM D2653-01 (elongation at first filament break test). The fibers of the present invention are further characterized by having (1) ratio of load at 200% elongation / load at 100% elongation of greater than or equal to 1.5, preferably greater than or equal to 1.6, preferably greater than or equal to 1.7, preferably greater than or equal to 1.8, preferably greater than or equal to 1.9, preferably greater than or equal to 2.0, preferably greater than or equal to 2.1, preferably greater than or equal to 2.2, preferably greater than or equal to 2.3, preferably greater than or equal to 2.4, and may be as high as 4 according to ASTM D2731-01 (under force at specified elongation in the finished fiber form).

[0200] The polyolefin may be selected from any suitable ethylene olefin block polymer. A particularly preferable olefin block polymer is an ethylene/ α -olefin interpolymer, wherein the ethylene/ α -olefin interpolymer has one or more of the following characteristics before crosslinking:

(1) an average block index greater than zero and up to 1.0 and a molecular weight distribution, Mw/Mn, greater than 1.3; or

(2) at least one molecular fraction which elutes between 40°C and 130°C when fractionated using TREF, characterized in that the fraction has a block index of at least 0.5 and up to 1; or

(3) an Mw/Mn from 1.7 to 3.5, at least one melting point, T_m , in degrees Celsius, and a density, d , in grams/cubic centimeter, wherein the numerical values of T_m and d correspond to the relationship:

$$T_m > -2002.9 + 4538.5(d) - 2422.2(d)^2;$$

or

(4) an Mw/Mn from 1.7 to 3.5, and is characterized by a heat of fusion, ΔH in J/g, and a delta quantity, ΔT , in degrees Celsius defined as the temperature difference between the tallest DSC peak and the tallest CRYSTAF peak, wherein the numerical values of ΔT and ΔH have the following relationships:

$$\Delta T > -0.1299(\Delta H) + 62.81$$

for ΔH greater than zero and up to 130 J/g,

$$\Delta T \geq 48^{\circ}\text{C}$$

5 for ΔH greater than 130 J/g,
 wherein the CRYSTAF peak is determined using at least 5 percent of the cumulative polymer, and if less than 5
 percent of the polymer has an identifiable CRYSTAF peak then the CRYSTAF temperature is 30°C; or

10 (5) an elastic recovery, R_e , in percent at 300 percent strain and 1 cycle measured with a compression-molded film
 of the ethylene/ α -olefin interpolymer, and has a density, d , in grams/cubic centimeter, wherein the numerical values
 of R_e and d satisfy the following relationship when ethylene/ α -olefin interpolymer is substantially free of a cross-
 linked phase:

$$15 \quad R_e > 1481 - 1629(d);$$

$R_e > 1481 - 1629(d)$; or

20 (6) a molecular fraction which elutes between 40°C and 130°C. when fractionated using TREF, characterized in
 that the fraction has a molar comonomer content of at least 5 percent higher than that of a comparable random
 ethylene interpolymer fraction eluting between the same temperatures, wherein said comparable random methylene
 interpolymer has the same comonomer(s) and has a melt index, density, and molar comonomer content (based on
 the whole polymer) within 10 percent of that of the ethylene/ α -olefin interpolymer, or

25 (7) a storage modulus at 25 °C, $G'(25^{\circ}\text{C})$, and a storage modulus at 100 °C, $G'(100^{\circ}\text{C})$, wherein the ratio of $G'(25^{\circ}\text{C})$
 to $G'(100^{\circ}\text{C})$ is in the range of 1:1 to 9:1.

[0201] The fibers may be made into any desirable size and cross-sectional shape depending upon the desired appli-
 cation. For many applications approximately round cross-section is desirable due to its reduced friction. However, other
 30 shapes such as a trilobal shape, or a flat (i.e., "ribbon" like) shape can also be employed. Denier is a textile term which
 is defined as the grams of the fiber per 9000 meters of that fiber's length. Preferred denier sizes depend upon the type
 of fabric and desired applications. Typically, knit fabrics comprise a majority of the fibers having a denier from at least
 1, preferably at least 20, preferably at least 50, to at most 180, preferably at most 150, preferably at most 100 denier,
 preferably at most 80 denier. Woven fabrics, on the other hand, may comprise a majority of the fibers having a denier
 35 that is larger than knits and can be up to 3000 denier.

[0202] Depending upon the applications the fiber may take any suitable form including a staple fiber or binder fiber.
 Typical examples may include a homofil fiber, a bicomponent fiber, a meltblown fiber, a meltspun fiber, or a spunbond
 fiber. In the case of a bicomponent fiber it may have a sheath-core structure; a sea-island structure; a side-by-side
 structure; a matrix-fibril structure; or a segmented pie structure. Advantageously, conventional fiber forming processes
 40 may be employed to make the aforementioned fibers. Such processes include those described in, for example, U.S.
 Patents No. 4,340,563; 4,663,220; 4,668,566; 4,322,027; and 4,413,1101.

[0203] Depending upon their composition, the fibers may be made to facilitate processing and unwind the same as
 or better from a spool than other fibers. Ordinary fibers when in round cross section often fail to provide satisfactory
 unwinding performance due to their base polymer excessive stress relaxation This stress relaxation is proportional to
 45 the age of the spool and causes filaments located at the very surface of the spool to lose grip on the surface, becoming
 loose filament strands. Later, when such a spool containing conventional fibers is placed over the rolls of positive feeders,
 i.e. Memminger-IRO, and starts to rotate to industrial speeds, i.e. 100 to 300 rotations/minute, the loose fibers are thrown
 to the sides of the spool surface and ultimately fall off the edge of the spool. This failure is know as derails which denotes
 the tendency of conventional fibers to slip off the shoulder or edge of the package which disrupts the unwinding process
 50 and ultimately causes machine stops. The above fibers may exhibit derailing to the same or a much less significant
 degree which possibly allows greater throughput.

[0204] Another advantage of the fibers is that defects such as fabric faults and elastic filament or fiber breakage may
 be equivalent or reduced as compared to conventional fibers. That is, use of the above fibers may reduce buildup of
 fiber fragments on a needle bed - a problem that often occurs in circular knit machines when polymer residue adheres
 55 to the needle surface. Thus, the fibers may reduce the corresponding fabric breaks caused by the residue when the
 fibers are being made into, e.g. fabrics on a circular knitting machine.

[0205] Another advantage is that the fibers may be knitted in circular machines where the elastic guides that drive the

filament all the way from spool to the needles are stationary such as ceramic and metallic eyelets. In contrast, some conventional elastic olefin fibers require that these guides be made of rotating elements such as pulleys as to minimize friction as machine parts, such as eyelets, are heated up so that machine stops or filament breaks could be avoided during the circular knitting process. That is, the friction against the guiding elements of the machine is reduced by using the inventive fibers. Further information concerning circular knitting is found in, for example, Bamberg Meisenbach, "Circular Knitting: Technology Process, Structures, Yarns, Quality", 1995.

Additives

[0206] Antioxidants, e.g., IRGAFOS® 168, IRGANOX® 1010, IRGANOX® 3790, and CHIMASSORB® 944 made by Ciba Geigy Corp., may be added to the ethylene polymer to protect against undo degradation during shaping or fabrication operation and/or to better control the extent of grafting or crosslinking (i.e., inhibit excessive gelation). In-process additives, e.g. calcium stearate, water, fluoropolymers, etc., may also be used for purposes such as for the deactivation of residual catalyst and/or improved processability. TINUVIN® 770 (from Ciba-Geigy) can be used as a light stabilizer.

[0207] The copolymer can be filled or unfilled. If filled, then the amount of filler present should not exceed an amount that would adversely affect either heat-resistance or elasticity at an elevate temperature. If present, typically the amount of filler is between 0.01 and 80 wt % based on the total weight of the copolymer (or if a blend of a copolymer and one or more other polymers, then the total weight of the blend). Representative fillers include kaolin clay, magnesium hydroxide, zinc oxide, silica and calcium carbonate. Preferably, when a filler is present, the filler is coated with a material that will prevent or retard any tendency that the filler might otherwise have to interfere with the crosslinking reactions. Stearic acid is illustrative of such a filler coating.

[0208] To reduce the friction coefficient of the fibers, various spin finish formulations can be used, such as metallic soaps dispersed in textile oils (see for example U.S. Patent No. 3,039,895 or U.S. Patent No. 6,652,599), surfactants in a base oil (see for example US publication 2003/0024052) and polyalkylsiloxanes (see for example U.S. Patent No. 3,296,063 or U.S. Patent No. 4,999,120). U.S. Patent Application No. 10/933,721 (published as US20050142360) discloses spin finish compositions that can also be used.

Fabrics

[0209] The present invention is also directed to improved, dyed textile articles comprising an olefin block copolymer. For purposes of the present invention, "textile articles" includes fabric as well as articles, i.e., garments, made from the fabric including, for example, clothing and other items in need of coloring. By knitting it is meant intertwining yam or thread in a series of connected loops either by hand, with knitting needles, or on a machine. The present invention may be applicable to any type of knitting including, for example, warp or weft knitting, flat knitting, and circular knitting. Particularly preferred warp knits include tricot and raschel while preferred weft knits include circular, flat, and seamless. However, the invention is particularly advantageous when employed in circular knitting, i.e., knitting in the round, in which a circular needle is employed. The present invention may also be applicable to any type of woven fabric.

[0210] The dyed fabrics of the present invention preferably comprise one or more elastic fibers wherein the elastic fibers comprise the reaction product of at least one ethylene olefin block polymer and at least one crosslinking agent wherein the ethylene olefin block polymer is an ethylene/ α -olefin interpolymers, wherein the ethylene/ α -olefin interpolymers has one or more of the following characteristics prior to crosslinking:

(1) an average block index greater than zero and up to 1.0 and a molecular weight distribution. Mw/Mn, greater than 1.3; or

(2) at least one molecular fraction which elutes between 40°C and 130°C when fractionated using TREF, characterized in that the fraction has a block index of at least 0.5 and up to 1: or

(3) an Mw/Mn from 1.7 to 3.5, at least one melting point, T_m, in degrees Celsius, and a density, d, in grams/cubic centimeter, wherein the numerical values of T_m and d correspond to the relationship:

$$T_m > -2002.9 + 4538.5(d) - 2422.2(d)^2;$$

or

(4) an Mw/Mn from 1.7 to 3.5, and is characterized by a heat of fusion, ΔH in J/g, and a delta quantity, ΔT , in degrees

EP 2 102 396 B1

Celsius defined as the temperature difference between the tallest DSC peak and the tallest CRYSTAF peak, wherein the numerical values of ΔT and ΔH have the following relationships:

$$\Delta T > -0.1299(\Delta H) + 62.81$$

for ΔH greater than zero and up to 130 J/g,

$$\Delta T \geq 48^{\circ}\text{C}$$

for ΔH greater than 130 J/g ,

wherein the CRYSTAF peak is determined using at least 5 percent of the cumulative polymer, and if less than 5 percent of the polymer has an identifiable CRYSTAF peak, then the CRYSTAF temperature is 30°C; or

(5) an elastic recovery. R_e , in percent at 300 percent strain and 1 cycle measured with a compression-molded film of the ethylene/ α -olefin Interpolymer, and has a density, d , in grams/cubic centimeter, wherein the numerical values of R_e and d satisfy the following relationship when ethylene/ α -olefin interpolymer is substantially free of a cross-linked phase:

$$R_e > 1481 - 1629(d);$$

or

(6) a molecular fraction which elutes between 40°C and 130°C when fractionated using TREF, characterized in that the fraction has a molar comonomer content of at least 5 percent higher than that of a comparable random ethylene interpolymers fraction eluting between the same temperatures, wherein said comparable random ethylene interpolymer has the same comonomer(s) and has a melt index, density, and molar comonomer content (based on the whole polymer) within 10 percent of that of the ethylene/ α -olefin interpolymer; or

(7) a storage modulus at 25 °C, $G'(25^{\circ}\text{C})$, and a storage modulus at 100 °C, $G'(100^{\circ}\text{C})$, wherein the ratio of $G'(25^{\circ}\text{C})$ to $G'(100^{\circ}\text{C})$ is in the range of 1:1 to 9:1.

[0211] The amount of polymer in the dyed fabric varies depending upon the polymer, the application and the desired properties. The dyed fabrics typically comprise at least 1, preferably at least 2, preferably at least 5, preferably at least 7 weight percent ethylene/ α -olefin interpolymer. The fabrics typically comprise less than 50, preferably less than 40, preferably less than 30, preferably less than 20, more preferably less than 10 weight percent ethylene/ α -olefin interpolymer. The ethylene/ α -olefin interpolymer may be in the form of a fiber and may be blended with another suitable polymer, e.g. polyolefins such as random ethylene copolymers, HDPE, LLDPE, LDPE, ULDPE, polypropylene homopolymers, copolymers, plastomers and elastomers, lastol, a polyamide, etc.

[0212] The ethylene/ α -olefin interpolymer of the fabric may have any density but is usually at least 0.85 and preferably at least 0.865 g/cm³ (ASTM D 792). Correspondingly, the density is usually less than 0.93, preferably less than 0.92 g/cm³ (ASTM D 792). The ethylene/ α -olefin interpolymer of the fabric is characterized by an uncrosslinked melt index of from 0.1 to 10 g/10 minutes. If crosslinking is desired, then the percent of cross-linked polymer is often at least 10 percent, preferably at least 20, more preferably at least 25 weight percent to at most 90, preferably at most 75, as measured by the weight percent of gels formed.

[0213] The fabrics often comprise another material selected from the group consisting of rayon, nylon, viscose, polyester such as microfiber polyester, polyamide, polypropylene, cellulose, cotton, flax, ramie, hemp, wool, silk, linen, bamboo, tencel, mohair, other natural fibers, other sythetic fibers, and mixtures thereof. Often the other material comprises the majority of the fabric. In such case it is preferred that the other material comprise from at least 50, preferably at least 60, preferably at least 70, preferably at least 80, sometimes as much as 90-95, percent by weight of the fabric.

[0214] The ethylene/ α -olefin interpolymer, the other material or both may be in the form of a fiber. Preferred sizes include a denier from at least 1, preferably at least 20, preferably at least 50, to at most 180, preferably at most 150, preferably at most 100, preferably at most 80 denier.

[0215] Particularly preferred circular knit fabrics comprise ethylene/ α -olefin interpolymers in the form of a fiber in an

amount of from 5 to 20 percent (by weight) of the fabric. Particularly preferred warp knit fabrics comprise ethylene/ α -olefin interpolymers in the form of a fiber in an amount of from 10 to 30 percent (by weight) of the fabric in the form of a fiber. Often such warp knit and circular knit fabrics also comprise polyester or microfiber polyester.

[0216] The fabric, particularly knit fabrics, often have less than 5, preferably less than 4, preferably less than 3, preferably less than 2, preferably less than 1, preferably less than 0.5, preferably less than 0.25, percent shrinkage after wash according to AATCC 135 in either the horizontal direction, the vertical direction, or both. More specifically, the fabric (after heat setting) often has a dimensional stability of from 7% to +7%, preferably -5% to +5%, preferably from -3% to +3%, preferably -2% to +2%, more preferably -1% to +1% in the lengthwise direction, the widthwise direction, or both according to AATCC135 IVAi. In addition, the fabrics often have less shrinkage after wash according to AATCC 135 IVAi than a comparable fabric of elastic fibers with a higher amount of crosslinking.

[0217] Knit fabrics can be made to stretch in two dimensions if desired by controlling the type and amount of ethylene/ α -olefin interpolymers and other materials. Knit fabrics may sometimes be characterized by a stretch of at least 30 percent measured according to ASTM D2594. Similarly, the fabric can be made such that the growth in the lengthwise and widthwise directions is less than 7, preferably less than 5, preferably less than 4, preferably less than 3, preferably less than 2, preferably less than 1, to as little as 0.5 percent according to ASTM D 2594. Using the same test (ASTM D 2594) the lengthwise growth at 60 seconds can be less than 15, preferably less than 12, preferably less than 10, preferably less than 8%. Correspondingly, using the same test (ASTM D 2594) the widthwise growth at 60 seconds can be less than 20, preferably less than 18, preferably less than 16, preferably less than 13%. In regard to the 60 minute test of ASTM D 2594, the widthwise growth can be less than 10, preferably less than 9, preferably less than 8, preferably less than 6% while the lengthwise growth at 60 minutes can be less than 8, preferably less than 7, preferably less than 6, preferably less than 5%. The lower growth described above allows the fabrics of the invention to be heat set at temperatures from less than 180, preferably less than 170, preferably less than 160, preferably less than 150°C while still controlling size. In contrast to knit fabrics, woven fabrics may be characterized by a stretch of at least 10 percent measured according to ASTM D3107.

[0218] Advantageously, knit fabrics of the present invention can be made without a substantial number of breaks and using a knitting machine comprising an eyelet feeder system, a pulley system, or a combination thereof. Thus, the circular knitted stretch fabrics having improved moldability while having acceptable dimensional stability (lengthwise and widthwise), acceptable growth and shrinkage, the ability to be heat set at low temperatures while controlling size, low moisture regain can be made without significant breaks, with high throughput, and without derailing in a wide variety of circular knitting machines.

Dyeing

[0219] The dyed fabrics of the present invention may be made by virtually any dyeing process. For example, many useful techniques are described in Fundamentals of Dyeing and Printing, by Garry Mock, North Carolina State University 2002, ISBN 9780000033871. One advantage of the fabrics of the present invention is that they may often be contacted with the dye at a temperature of at least 130°C to produce a dyed fabric wherein the fabric exhibits a growth to stretch ratio of less than 0.5, preferably less than 0.4, preferably less than 0.35, preferably less than 0.3, preferably less than 0.25, preferably less than 0.2, preferably less than 0.15, preferably less than 0.1, preferably less than 0.05. Advantageously, the resulting dyed fabrics of the present invention are often characterized by a color change of greater than or equal to 3.0, preferably greater than or equal to 3.5, more preferably greater than or equal to 4.0 according to AATCC evaluation after a first wash by AATCC61-2003-2A. Another advantage is that the fabrics of the present invention may sometimes exhibit a color change of greater than or equal to 2.5, preferably greater than or equal to 3.0, more preferably greater than or equal to 3.5 according to AATCC evaluation after a second wash by AATCC61-2003-2A. In essence this means that the dyed fabrics of the present invention may exhibit less fading when subjected to laundering than conventional dyed fabrics.

[0220] The dyed fabrics of the present invention are also characterized by an advantageous color strength after dyeing, i.e., the fabrics are darker. For example, the dyed fabrics may often be characterized by a color strength after dyeing of greater than or equal to 600, preferably of greater than or equal to 650, preferably of greater than or equal to 700, preferably of greater than or equal to 750, as measured with a spectrum photometer. Advantageously, the color is substantially retained even after a first and second wash. For example, the dyed fabrics may be characterized by a color strength after a first wash by AATCC61-2003-2A that is at least 90, preferably at least 95, more preferably at least 97 percent of the color strength after dyeing wherein each color strength is measured with a spectrum photometer. The dyed fabrics may sometimes also be characterized by a color strength after a second wash by AATCC61-2003-2A that is at least 90, preferably at least 92.5, more preferably at least 94 percent of the color strength after dyeing wherein each color strength is measured with a spectrum photometer.

[0221] While not wishing to be bound by any theory it is believed that the reason the dyed fabrics of the present invention dye darker is due to the fibers of the olefins block polymer. That is the olefin block polymer fibers dye to a

lesser extent allowing the other material to get darker. Also, a higher dyeing temperature can be employed with less fiber breakage when olefin block polymers are used as the fibers. In a similar manner it is believed that the reason the dyed fabrics fade less upon laundering is that the olefin block polymer fibers are not dyed to as great of an extent as fibers made with other polymers. In this manner, the olefins block polymers cannot fade or bleed as much.

EXAMPLES

Example 22 - Fibers of elastic ethylene/ α -olefin interpolymer

[0222] The elastic ethylene/ α -olefin interpolymer. (olefins block polymer) of Example 20 was used to make monofilament fibers of 40 denier having an approximately round cross-section. Before the fiber was made the following additives were added to the polymer: 7000 ppm PDMSO (polydimethyl siloxane), 3000 ppm CYANOX 1790 (1.3.5-tris-(4-t-butyl-3-hydroxy-2,6-dimethylbenzyl)-1,3,5-triazine-2,4,6-(1H,3H,5H)-trione, and 3000 ppm CHIMASORB 944 Poly-[[6-(1.1,3,3-tetramethylbutyl) amino]-s-triazine-2,4-diyl] [2,2,6,6-tetramethyl-4-piperidyl] imino] hexamethylene[(2,2,6,6-tetramethyl-4-piperidyl)imino]] and 0.5% by weight TiO₂. The fibers were produced using a die profile with circular 0.8 mm diameter, a spin temperature of 299°C, a winder speed of 650m/minute, a spin finish of 2%, a cold draw of 6%, and a spool weight of 150g. The fibers were then crosslinked using a total of 176.4 kGy irradiation as the crosslinking agent.

Example 23 - Hard yarns of fibers

[0223] A hard yarn was made that comprised the elastic fibers of Example 22 and 150 denier, 288 filament polyester. The filament of microfiber is fine as 0.52 denier per filament. Two comparative examples were also made. One comparative example hard yarn employed 40 denier fibers of a random ethylene-octene copolymer made with a line speed of 450 m/min and the same 150 denier, 288 filament polyester fibers. The random ethylene-octene copolymer had an average melt index of 3.0 g/10min, a density of 0.875 g/cm³ and was crosslinked with a dosage of 166.4 kGy irradiation as the crosslinking agent. The second comparative example hard yarn was made with multi-filament fibers of Lycra™ 162 C polymer and the same 150 denier, 288 filament polyester fibers.

Example 24 - Dyeing

[0224] An experiment was designed to evaluate the elastic fiber color staining and the color darkness of microfiber polyester based fabrics. The experiment evaluated the disperse dyestuff staining on the fibers comprised of olefins block polymers, the fibers comprised of Lycra™ 162C, and the fibers comprised of random ethylene-octene copolymers. 1 gram of each of the three different types of fibers and 9 grams of micro-fiber polyester fabric (witness fabric that made the hard yarn was loaded in a lab rapid dyeing machine that is shown in Figure 8. The dyeing and reduction wash process as shown in Figure 9 was then conducted on each of the three different types of fibers. Clariant dyestuff Foron Black S-WF was used to dye the fibers and fabrics into black. The Lycra based fibers were dyed at 125 °C since this elastic fiber may undergo severe damage at higher temperatures. The other two types of fibers were dyed at 135 °C. The specimens of after dyeing, after 1st reduction wash and after 2nd reduction wash were collected for evaluation.

[0225] The three different types of fibers after dyeing and reduction wash were evaluated visually. The polyester micro fiber fabric was also tested to get color strength, color change and color staining value as an indication for color fastness. The dyed fibers were evaluated visually under D65 standard day light to define the color staining on fiber. Color strength (K/S) was measured with a spectrum photometer (**Data color model-600PLUS**). High K/S value represented darker color. Color change was measured according to AATCC 61-2003-2A that reports the color difference between original specimen and the specimen after wash. The quotation ranges from 1~5 by grey scale according to AATCC evaluation procedure. A lower grade indicates a bigger color change and therefore less colorfastness. The specimens after dyeing, after 1st reduction wash and after 2nd reduction wash were washed by AATCC 61-2003-2A and the color change before and after was measured.

[0226] Color staining is also based on the test of AATCC 61-2003-2A. A multifiber test fabric that consists of acetate, cotton, polyamide, acrylic and wool fiber, is attached to the specimen to wash. The test grades 1~5 and a lower grade means heavier color staining. Textile industry practice is to use the grade result of polyamide as an indication of color staining.

[0227] Lab dips of the three different types of elastic fibers after dyeing, after 1st reduction wash and after 2nd reduction wash were done. The results indicated good colorfastness and darker color for the fabrics comprising the olefin block polymer. Table 12 shows the elastic fiber color staining after dyeing, after 1st reduction wash and after 2nd reduction wash. More dyestuff uptake makes darker color on elastic fiber itself. High dyestuff uptake is positive to obtain dark colors but can be detrimental if it bleeds out during washing (home laundry). The Lycra™ fiber shows darkest color after

EP 2 102 396 B1

dyeing, after 1st reduction wash and after 2nd reduction wash. The random ethylene-octene copolymer and olefin block polymer fiber shows lighter color staining. The specimens are very similar after dyeing, after 1st reduction wash and after 2nd reduction wash. The olefin block polymer fiber shows less dyestuff uptake that helps better colorfastness in micro fiber polyester fabric colorfastness.

5

Table 12 Color staining

Testing item	Lycra 162C	Random ethylene octene copolymer	Olefin block polymer
Elastic Fiber color stain after dyeing	Darkest	Lighter	Lighter
Elastic fiber Color stain after 1 st RC ¹	Darkest	Lighter	Lighter
Elastic fiber Color stain after 2 nd RC	Darkest	Lighter	Lighter
¹ RC : Reduction Cleaning			

15

[0228] Table 13 shows the color strength (K/S) value of micro fiber polyester fabric. The higher value of K/S represented darker color. Witness micropolyester fabrics dyed with random ethylene-octene copolymer and olefin block polymer fibers showed darker black compared with Lycra. While not wishing to be bound to any theory it is believed that this result is due to the higher dyeing temperature employed. There were no significant differences among the samples after dyeing, after 1st reduction wash and after 2nd reduction wash. However, the microfiber polyester of olefin block polymer can reach a darker color.

20

Table 13 Color strength(K/S) value of fabrics

Testing item	Lycra 162C	Random ethyleneoctene copolymer	Olefin block polymer
Micro PES witness fabric Color strength (K/S) after dyeing	423.38	755.77	774.71
Micro PES witness fabric K/S after 1 st RC	414.68	783.83	753.67
Micro PES witness fabrics K/S alter 2 nd RC	411.75	753.00	739.86

35

[0229] Table 14 shows the color change value of micro fiber polyester after dyeing, after 1st reduction wash and after 2nd reduction wash. The higher value means lighter color change. All specimens show good color change results.

Table 14 Result of color change of micro polyester

Testing item	Lycra 162C	Random ethyleneoctene copolymer	Olefin block Polymer
Micro PES witness fabric Color change after dyeing	4	4	4
Micro PES witness fabric Color change after 1 st RC	4	4	4
Micro PES witness fabric Color change after 2 nd RC	4	4	4

50

[0230] Table 15 shows the color staining to polyamide fabric (testing fabric). The higher value means less color staining. The fabrics after reduction wash show better color staining. There is no obvious difference between the results shown after 1st and 2nd reduction wash. The dyed, witness fabrics of random ethylene-octene copolymer and olefin block polymer are darker than the dyed Lycra fabric and this has an effect on the color fastness as given in Table 12. None of the results involve fabric heat setting.

55

Table 15 Color staining to polyamide fabric

Testing item	Lycra 162C	Random ethyleneoctene copolymer	Olefin block polymer
Micro PES witness fabric Color fastness to wash after dyeing	3	2.5	2.5
Micro PES witness fabric Color fastness to wash after 1 st RC	3.5	3.5	3.5
Micro PES witness fabric Color fastness to wash after 2 nd RC	3.5	3.5	3.5

[0231] Three single jersey knits are use in this test. They are micro fiber polyester hard yam knitted with 40 denier Lycra, 40 denier random ethylene-octene copolymer and 40 denier olefin block polymer fiber. The knitting speed, elastic draft and the fabric weight of greige are given in Table 16.

Table 16 Fabric description of various elastic fiber contented fabric

Sample	Speed (rpm)	D.R.	Greige
Lycra 162C	12.4	2.6	203 g/m ²
Random ethyleneoctene copolymer	12.4	2.6	170 g/m ²
Olefin Block Polymer	20	3.2	186 g/m ²

[0232] Random ethylene-octene copolymer and olefin block polymer greige are scoured at 85°C for 20 minutes, dried at 135°C for 45 minutes, tensionless dried at 130C for 60 minutes, set at 165°C for 120 seconds (15 yards per minute) at 20% overfeed, and finished. The dyeing and reduction conditions are given in Figure 9 for random ethylene-octene copolymer and olefin block polymer containing fabric. The Lycra greige is dyed at 125 °C and heat set at 185 °C. The finished fabric is described in Table 17.

Table 17 Fabric weight of various elastic fiber contented fabric

Sample ID	Finished weight
Lycra 162C	269 g/m ²
Random ethyleneoctene copolymer	210 g/m ²
Olefin Block Polymer	190 g/m ²

[0233] Table 18 shows the test result of AATCC 61-2003-2A, random ethylene-octene copolymer and olefin block polymer both have excellent performance in color change compared with Lycra 162 before or after heat setting. The reason is random ethylene-octene copolymer and olefin block polymer fiber were dyed at 135°C, the disperse dyestuff has better reaction in this temperature. In the dye lot of micro-fiber polyester/Lycra, there is un-reacted disperse dyestuff because of low dyeing temperature that stained on fabric and bleeds out that makes specimen color fading during testing. Random ethylene-octene copolymer and OBC both has good color fastness to polyamide compared with Lycra. Lycra shows poor color fastness after heat setting. The reason is the disperse dyes migrated during 185°C high temperature heat setting.

Table 18 Test result of color change and color fastness of fabrics

Testing item	Lycra 162C	Random ethyleneoctene copolymer	Olefin Block Polymer
Color change after RC	3	4	4
Color change after heat setting	2.5	4	4
Color fastness to wash after RC	3	3.5	3.5
Color fastness to wash after heat setting	2	3.5	4

[0234] Three finished fabrics after heat setting were tested by spectrum photometer (Datacolor model-600PLUS). Table 19 shows the color strength (K/S) that indicates darkness. The micro-fiber polyester knits containing random ethylene-octene copolymer and olefin block polymer have darker color compared with the knits containing Lycra that used same dyeing formulation.

Table 19 Fabric width of greige and finished goods

Testing item	Lycra 162C	Random ethyleneoctene copolymer	OBC EXP 6116
Color strength (K/S)	454.23	747.55	774.18

Example 25 - Varying Amounts of Fiber Crosslinking

[0235] The elastic ethylene/ α -olefin interpolymer of Example 20 was used to make monofilament fibers of 40 denier having an approximately round cross-section. Before the fiber was made the following additives were added to the polymer: 7000 ppm PDMSO (polydimethyl siloxane), 3000 ppm CYANOX 1790 (1,3,5-tris-(4-t-butyl-3-hydroxy-2,6-dimethylbenzyl)-1,3,5-triazine-2,4,6-(1H,3H,5H)-trione, and 3000 ppm CHIMASORB 944 Poly-[[6-(1,1,3,3-tetramethyl-butyl)amino]-s-triazine-2,4-diy][2,2,6,6-tetramethyl-4-piperidyl]imino]hexamethylene[(2,2,6,6-tetramethyl-4-piperidyl)imino]] and 0.5% by weight TiO₂. The fibers were produced using a die profile with circular 0.8 mm diameter, a spin temperature of 299°C, a winder speed of 650m/minute, a spin finish of 2%, a cold draw of 6%, and a spool weight of 150g. Fibers were then crosslinked using varying amounts of irradiation from an e-beam as the crosslinking agent.

[0236] The gel content versus the amount of irradiation is shown in Figure 11. The gel content was determined by weighing out an approximately 25 mag fiber sample to 4 significant figure accuracy. The sample is then combined with 7 ml xylene in a capped 2-dram vial. The vial is heated 90 minutes at 125°C to 135°C, with inversion mixing (i.e. turning vial upside down) every 15 minutes, to extract essentially all the non-crosslinked polymer. Once the vial has cooled to approximately 25°C, the xylene is decanted from the gel. The gel is rinsed in the vial with a small portion of fresh xylenes. The rinsed gel is transferred to a tared aluminum weighing pan. The tared dish with gel is vacuum dried at 125°C for 30 minutes to remove the xylene by evaporation. The pan with dried gel is weighed on an analytical balance. The gel content is calculated based on the extracted gel weight and original fiber weight. Figure 11 shows that as the e-beam dosage increases, the amount of crosslinking (gel content) increases. One skilled in the art will appreciate that the precise relationship between the amount of crosslinking and e-beam dosage may be affected by a given polymer's properties, e.g., molecular weight or melt index.

Claims

1. A dyed fabric comprising one or more elastic fibers wherein the elastic fibers comprise the reaction product of at least one ethylene olefin block polymer and at least one chemical or radiation crosslinking agent wherein said fabric is in the form of (1) a woven fabric which is **characterized by** a stretch of at least 10 percent measured according to ASTM D31.07 or (2) a knit fabric which is **characterized by** a stretch of at least 30 percent measured according to ASTM D2594, and wherein said fabric is **characterized by** a color change of greater than or equal to 3.0 according to AATCC evaluation after a first wash by AATCC61-2003-2A.
2. The dyed fabric of claim 1 wherein said fabric is **characterized by** a color strength after dyeing of greater than or equal to 600 as measured with a spectrum photometer.
3. The dyed fabric of claim 1 or 2 wherein said fabric is **characterized by** a color change of greater than or equal to 3.5 according to AATCC evaluation after a first wash by AATCC61-2003-2A.
4. The dyed fabric of any one of claims 1 to 3 wherein the ethylene olefin block polymer is an ethylene/ α -olefin interpolymer **characterized by** one or more of the following characteristics prior to crosslinking:

(a) has a Mw/Mn from 1.7 to 3.5, at least one melting point, T_m, in degrees Celsius, and a density, d, in grams/cubic centimetre, wherein the numerical values of T_m and d correspond to the relationship:

$$T_m > -2002.9 + 4538.5(d) - 2422.2(d)^2,$$

EP 2 102 396 B1

or

(b) has a Mw/Mn from 1.7 to 3.5, and is **characterized by** a heat of fusion, ΔH in J/g, and a delta quantity, ΔT , in degrees Celsius defined as the temperature difference between the tallest DSC peak and the tallest CRYSTAL peak, wherein the numerical values of ΔT and ΔH have the following relationships:

$$\Delta T > -0.1299(\Delta H) + 62.81$$

for ΔH greater than zero and up to 130 J/g,

$$\Delta T \geq 48^\circ\text{C}$$

for ΔH greater than 130 J/g, wherein the CRYSTAF peak is determined using at least 5 percent of the cumulative polymer, and if less than 5 percent of the polymer has an identifiable CRYSTAF peak, then the CRYSTAF temperature is 30°C; or

(c) is **characterized by** an elastic recovery, R_e , in percent at 300 percent strain and 1 cycle measured with a compression-molded film of the ethylene/ α -olefin interpolymer, and has a density, d , in grams/cubic centimetre, wherein the numerical values of R_e and d satisfy the following relationship when the ethylene/ α -olefin interpolymers is substantially free of a cross-linked phase:

$$R_e > 1481 - 1629(d) :$$

or

(d) has a molecular fraction which elutes between 40°C and 130°C when fractionated using TREF, **characterized in that** the fraction has a molar comonomer content of at least 5 percent higher than that of a comparable random ethylene interpolymer fraction eluting between the same temperatures, wherein said comparable random ethylene interpolymer has the same comonomer(a) and a melt index, density, and molar comonomer content (based on the whole polymer) within 10 percent of that of the ethylene/ α -olefin interpolymer; or

(e) is **characterized by** a storage modulus at 25°C $G'(25^\circ\text{C})$, and a storage modulus at 100°C, $G'(100^\circ\text{C})$, wherein the ratio of $G'(25^\circ\text{C})$ to $G'(100^\circ\text{C})$ is from 1:1 to 10:1; or

(f) at least one molecular fraction which elutes between 40°C and 130°C when fractionated using TREF, **characterized in that** the fraction has a block index of at least 0.5 and up to 1 and a molecular weight distribution, Mw/Mn, greater than 1.3 or

(g) an average block index greater than zero and up to 1.0 and a molecular weight distribution, Mw/Mn, greater than 1.3

5. The dyed fabric of any one of claims 1 to 3 wherein said elastic fibers comprise from 2 to 30 weight percent of the fabric.
6. The dyed fabric of claim 4 wherein the ethylene/ α -olefin interpolymer is **characterized by** a density of from 0.865 to 0.92 g/cm³ (ASTM D792) and an uncrosslinked melt index of from 0.1 to 10 g/10 minutes.
7. The dyed fabric of any one of claims 1 to 3 wherein said fabric is **characterized by** a color change of greater than or equal to 2.5 according to AATCC evaluation after a second wash by AATCC61-2003-2A.
8. The dyed fabric of any one of claims 1 to 3 wherein said fabric is **characterized by** a color strength after a first wash by AATCC61-2003-2A that is at least 90 percent of the color strength after dyeing wherein each color strength is measured with a spectrum photometer.
9. The dyed fabric of any one of claims 1 to 3 wherein said fabric further comprises polyester, nylon, or mixtures thereof.
10. The dyed fabric of claim 9 wherein said polyester is microfiber polyester.
11. The dyed fabric of claim 10 wherein the polyester comprises at least 80 percent by weight of the fabric.
12. The dyed fabric of claim 4 wherein the ethylene/ α -olefin interpolymer is blended with another polymer.

13. The dyed fabric of any one of claims 1 to 3 wherein a majority of the fibers have a denier of from 1 denier to 180 denier.
14. The dyed fabric of any one of claims 1 to 3 Wherein said dyed fabric exhibits a growth to stretch ratio of less than 0.25.
- 5 15. The dyed fabric of any one of claims 1 to 3 wherein the fabric is a woven fabric and comprises a majority of the fibers that have a denier of less than 3000 denier.

Patentansprüche

- 10 1. Gefärbtes Gewebe umfassend eine oder mehrere elastische Fasern, wobei die elastischen Fasern das Reaktionsprodukt von mindestens einem Ethylenolefin-Blockpolymer und mindestens einem chemischen oder Strahlungs-Vernetzungsmittel umfassen, wobei das Gewebe in der Form (1) einer Webware, die **gekennzeichnet ist durch** eine Dehnbarkeit von mindestens 10 Prozent, gemessen gemäß ASTM D3107 oder (2) einer Wirkware, die **gekennzeichnet ist durch** eine Dehnbarkeit von mindestens 30 Prozent, gemessen gemäß ASTM D2594, ist, und wobei das Gewebe **gekennzeichnet ist durch** eine Farbveränderung von größer als oder gleich 3,0 gemäß AATCC-Evaluierung nach einer ersten Wäsche **durch** AATCC61-2003-2A.
- 15 2. Gefärbtes Gewebe nach Anspruch 1, wobei das Gewebe **gekennzeichnet ist durch** eine Farbstärke nach Färbung von größer als oder gleich 600, wie mit einem Spektrum-Photometer gemessen.
- 20 3. Gefärbtes Gewebe nach Anspruch 1 oder 2, wobei das Gewebe **gekennzeichnet ist durch** eine Farbveränderung von größer als oder gleich 3,5 gemäß AATCC-Evaluierung nach einer ersten Wäsche **durch** AATCC61-2003-2A.
- 25 4. Gefärbtes Gewebe nach einem der Ansprüche 1 bis 3, wobei das Ethylenolefin-Blockpolymer ein Ethylen/ α -Olefin-Interpolymer ist, das **gekennzeichnet ist durch** eine oder mehrere der folgenden Eigenschaften vor dem Vernetzen:

(a) weist ein Mw/Mn von 1,7 bis 3,5 auf, mindestens einen Schmelzpunkt, T_m , in Grad Celsius, und eine Dichte, d , in Gramm/Kubikzentimeter, wobei die numerischen Werte von T_m und d der Beziehung

$$T_m > -2002,9 + 4538,5 (d) - 2422,2 (d)^2$$

entsprechen, oder

(b) weist ein Mw/Mn von 1,7 bis 3,5 auf, und ist **gekennzeichnet durch** eine Schmelzwärme, ΔH in J/g, und eine Delta-Menge, ΔT , in Grad Celsius, definiert als die Temperaturdifferenz zwischen dem höchsten DSC-Peak und dem höchsten CRYSTAF-Peak, wobei die numerischen Werte von ΔT und ΔH die folgenden Beziehungen aufweisen:

$$\Delta T > -0,1299(\Delta H) + 62,81 \text{ für } \Delta H \text{ größer als Null und bis zu } 130 \text{ J/g,}$$

$$\Delta T \geq 48^\circ\text{C für } \Delta H \text{ größer als } 130 \text{ J/g,}$$

wobei der CRYSTAF-Peak unter Verwendung von mindestens 5 Prozent des kumulativen Polymers bestimmt wird, und wenn weniger als 5 Prozent des Polymers einen identifizierbaren CRYSTAF-Peak aufweisen, dann ist die CRYSTAF-Temperatur 30°C ; oder

(c) ist **gekennzeichnet durch** eine elastische Erholung, Re , in Prozent bei 300 Prozent Dehnung und 1 Zyklus, gemessen mit einem formgepressten Film des Ethylen/ α -Olefin-Interpolymers, und weist eine Dichte, d , in Gramm/Kubikzentimeter auf, wobei die numerischen Werte von Re und d der folgenden Beziehung genügen, wenn das Ethylen/ α -Olefin-Interpolymer im Wesentlichen frei von einer vernetzten Phase ist:

$$Re > 1481 - 1629(d) ;$$

oder

EP 2 102 396 B1

- (d) weist eine molekulare Fraktion auf, die zwischen 40°C und 130°C eluiert, wenn unter Verwendung von TREF fraktioniert, **dadurch gekennzeichnet, dass** die Fraktion einen molaren Comonomergehalt von mindestens 5 Prozent höher als der einer vergleichbaren zufälligen Ethylen-Interpolymerfraktion, die zwischen den selben Temperaturen eluiert, aufweist, wobei das vergleichbare zufällige Ethylen-Interpolymer das/die selbe(n) Comonomer(e) und einen Schmelzindex, Dichte, und molaren Comonomergehalt (basierend auf dem gesamten Polymer) innerhalb 10 Prozent von dem des Ethylen/ α -Olefin-Interpolymers aufweist; oder
- (e) ist **gekennzeichnet durch** ein Speichermodul bei 25°C, $G'(25^\circ\text{C})$, und ein Speichermodul bei 100°C, $G'(100^\circ\text{C})$, wobei das Verhältnis von $G'(25^\circ\text{C})$ zu $G'(100^\circ\text{C})$ von 1:1 bis 10:1 ist; oder
- (f) weist mindestens eine molekulare Fraktion auf, die zwischen 40°C und 130°C eluiert, wenn unter Verwendung von TREF fraktioniert, **dadurch gekennzeichnet, dass** die Fraktion einen Blockindex von mindestens 0,5 und bis zu 1 und eine Molekulargewichtsverteilung, M_w/M_n , größer als 1,3 aufweist, oder
- (g) einen Blockindex größer als Null und bis zu 1,0 und eine Molekulargewichtsverteilung, M_w/M_n , größer als 1,3.
- 5
- 15
- 20
- 25
- 30
- 35
- 40
- 45
5. Gefärbtes Gewebe nach einem der Ansprüche 1 bis 3, wobei die elastischen Fasern von 2 bis 30 Gewichtsprozent des Gewebes umfassen.
 6. Gefärbtes Gewebe nach Anspruch 4, wobei das Ethylen/ α -Olefin-Interpolymer **gekennzeichnet ist durch** eine Dichte von 0,865 bis 0,92 g/cm³ (ASTM D792) und einen unvernetzten Schmelzindex von 0,1 bis 10 g/10 Minuten.
 7. Gefärbtes Gewebe nach einem der Ansprüche 1 bis 3, wobei das Gewebe **gekennzeichnet ist durch** eine Farbveränderung von größer als oder gleich 2,5 gemäß AATCC-Evaluierung nach einer zweiten Wäsche **durch** AATCC61-2003-2A.
 8. Gefärbtes Gewebe nach einem der Ansprüche 1 bis 3, wobei das Gewebe **gekennzeichnet ist durch** eine Farbstärke nach einer ersten Wäsche **durch** AATCC61-2003-2A, die mindestens 90 Prozent der Farbstärke nach Färbung ist, wobei jede Farbstärke mit einem Spektrum-Photometer gemessen wird.
 9. Gefärbtes Gewebe nach einem der Ansprüche 1 bis 3, wobei das Gewebe weiter Polyester, Nylon, oder Mischungen davon umfasst:
 10. Gefärbtes Gewebe nach Anspruch 9, wobei der Polyester Mikrofaser-Polyester ist.
 11. Gefärbtes Gewebe nach Anspruch 10, wobei der Polyester mindestens 80 Gewichtsprozent des Gewebes umfasst.
 12. Gefärbtes Gewebe nach Anspruch 4, wobei das Ethylen/ α -Olefin-Interpolymer mit einem anderen Polymer vermischt ist.
 13. Gefärbtes Gewebe nach einem der Ansprüche 1 bis 3, wobei eine Mehrheit der Fasern einen Denier von 1 Denier bis 180 Denier aufweist.
 14. Gefärbtes Gewebe nach einem der Ansprüche 1 bis 3, wobei das gefärbte Gewebe ein Wachstums- zu Dehnungsverhältnis von weniger als 0,25 aufweist.
 15. Gefärbtes Gewebe nach einem der Ansprüche 1 bis 3, wobei das Gewebe Webware ist und eine Mehrheit der Fasern umfasst, die einen Denier von weniger als 3000 Denier aufweist.

Revendications

- 50
- 55
1. Etoffe teinte, comprenant des fibres élastiques d'une ou de plusieurs sortes, lesquelles fibres élastiques comprennent le produit de réaction d'au moins un polymère à blocs d'éthylène et d'oléfine et d'au moins un agent de réticulation, de nature chimique ou radiative, laquelle étoffe se présente sous la forme
 - 1) d'une étoffe tissée qui est **caractérisée par** une extensibilité, mesurée selon la norme ASTM D3107, d'au moins 10 %,
 - 2) ou d'une étoffe tricotée qui est **caractérisée par** une extensibilité, mesurée selon la norme ASTM D2594, d'au moins 30 %, et laquelle étoffe est **caractérisée par** un changement de couleur supérieur ou égal à 3,0 sur l'échelle d'évaluation AATCC, après un premier lavage effectué selon

EP 2 102 396 B1

la norme AATCC61-2003-2A,

2. Etoffe teinte conforme à la revendication 1, laquelle étoffe est **caractérisée par** une intensité de la couleur après teinture, mesurée à l'aide d'un spectrophotomètre, qui est supérieure ou égale à 600.

3. Etoffe teinte conforme à la revendication 1 ou 2, laquelle étoffe est **caractérisée par** un changement de couleur supérieur ou égal à 3,5 sur l'échelle d'évaluation AATCC, après un premier lavage effectué selon la norme AATCC61-2003-2A.

4. Etoffe teinte conforme à l'une des revendications 1 à 3, dans laquelle le polymère à blocs d'éthylène et d'oléfine est un interpolymère d'éthylène et d'alpha-oléfine qui, avant réticulation, est **caractérisé par** l'une ou plusieurs des caractéristiques suivantes :

a) il présente un indice M_w/M_n valant de 1,7 à 3,5, et au moins un point de fusion T_m et une masse volumique d dont les valeurs numériques, exprimées respectivement en degrés Celsius et en grammes par centimètre-cube, vérifient l'inégalité suivante :

$$T_m \geq -2002,9 + 4538,5(d) - 2422,2(d)^2 ;$$

b) ou il présente un indice M_w/M_n valant de 1,7 à 3,5, et se **caractérise par** une chaleur de fusion ΔH , exprimée en J/g, et une quantité ΔT , exprimée en degrés Celsius et définie comme étant la différence de température entre le plus grand pic observé en analyse AED et le plus grand pic observé en analyse CRYSTAF, dont les valeurs numériques vérifient les inégalités suivantes :

pour $0 < \Delta H \leq 130$ J/g, $\Delta T > -0,1299(\Delta H) + 62,81$ et pour $\Delta H > 130$ J/g, $\Delta T \geq 48$ °C,

étant entendu que le pic CRYSTAF est déterminé pour au moins 5 % de polymère en pourcentage cumulé, et que l'on prend la valeur de 30 °C pour la température du pic CRYSTAF si une fraction de moins de 5 % du polymère donne un pic CRYSTAF identifiable ;

c) ou il se **caractérise par** une recouvrance élastique Re pour une déformation de 300 % et 1 cycle, exprimée en pourcentage et mesurée sur un film de l'interpolymère d'éthylène et d'alpha-oléfine obtenu par moulage par compression, et présente une masse volumique d , exprimée en grammes par centimètre-cube, dont les valeurs numériques vérifient l'inégalité suivante quand l'interpolymère d'éthylène et d'alpha-oléfine ne contient pratiquement pas de phase réticulée :

$$Re > 1481 - 1629(d) ;$$

d) ou il présente une fraction moléculaire, éluee entre 40 et 130 °C en fractionnement TREF, qui est **caractérisée par** une teneur molaire en comonomère supérieure d'au moins 5 % à celle d'une fraction, éluee entre les mêmes températures, d'un interpolymère statistique d'éthylène comparable, lequel interpolymère statistique d'éthylène comparable comporte le(s) même(s) comonomère(s) et présente un indice de fluidité à chaud, une masse volumique et une teneur molaire en comonomère (rapportée au polymère entier) égaux, à 10 % près, à ceux de l'interpolymère d'éthylène et d'alpha-oléfine ;

e) ou il se **caractérise par** un module de conservation à 25 °C G'_{25} et un module de conservation à 100 °C G'_{100} qui ont des valeurs telles que le rapport de G'_{25} à G'_{100} vaut de 1/1 à 10/1 ;

f) ou il présente au moins une fraction moléculaire, éluee entre 40 et 130 °C en fractionnement TREF, qui est **caractérisée en ce que** cette fraction présente un indice de bloc qui vaut au moins 0,5 et jusqu'à 1 et un indice de distribution des masses moléculaires M_w/M_n supérieur à 1,3;

g) ou il présente un indice moyen de bloc qui vaut plus de 0 et jusqu'à 1,0 et un indice de distribution des masses moléculaires M_w/M_n supérieur à 1,3.

5. Etoffe teinte conforme à l'une des revendications 1 à 3, dans laquelle lesdites fibres élastiques représentent de 2 à 30 % du poids de l'étoffe.

6. Etoffe teinte conforme à la revendication 4, dans laquelle l'interpolymère d'éthylène et d'alpha-oléfine est **caractérisé par** une masse volumique de 0,865 à 0,92 g/cm³ (norme ASTM D792) et un indice de fluidité à chaud, à l'état non

EP 2 102 396 B1

réticulé, de 0,1 à 10 grammes par 10 minutes.

- 5
7. Etoffe teinte conforme à l'une des revendications 1 à 3, laquelle étoffe est **caractérisée par** un changement de couleur supérieur ou égal à 2,5 sur l'échelle d'évaluation AATCC, après un deuxième lavage effectué selon la norme AATCC61-2003-2A.
- 10
8. Etoffe teinte conforme à l'une des revendications 1 à 3, laquelle étoffe est **caractérisée par** une intensité de la couleur, après un premier lavage effectué selon la norme AATCC61-2003-2A, valant au moins 90 % de l'intensité de la couleur après teinture, étant entendu que chaque intensité de la couleur est mesurée à l'aide d'un spectrophotomètre.
- 15
9. Etoffe teinte conforme à l'une des revendications 1 à 3, laquelle étoffe comprend en outre un polyester, un nylon ou un mélanges de telles matières.
10. Etoffe teinte conforme à la revendication 9, dans laquelle ledit polyester est un polyester en microfibres.
11. Etoffe teinte conforme à la revendication 10, dans laquelle le polyester représente au moins 80 % du poids de l'étoffe.
- 20
12. Etoffe teinte conforme à la revendication 4, dans laquelle l'interpolymère d'éthylène et d'alpha-oléfine est mélangé avec un autre polymère.
13. Etoffe teinte conforme à l'une des revendications 1 à 3, dans laquelle une majeure partie des fibres présentent un titre de 1 denier à 180 deniers.
- 25
14. Etoffe teinte conforme à l'une des revendications 1 à 3, laquelle étoffe teinte présente un rapport de l'allongement rémanent à l'extensibilité qui est inférieur à 0,25.
- 30
15. Etoffe teinte conforme à l'une des revendications 1 à 3, laquelle étoffe est une étoffe tissée qui comprend en majorité des fibres dont le titre est inférieur à 3000 deniers.

35

40

45

50

55

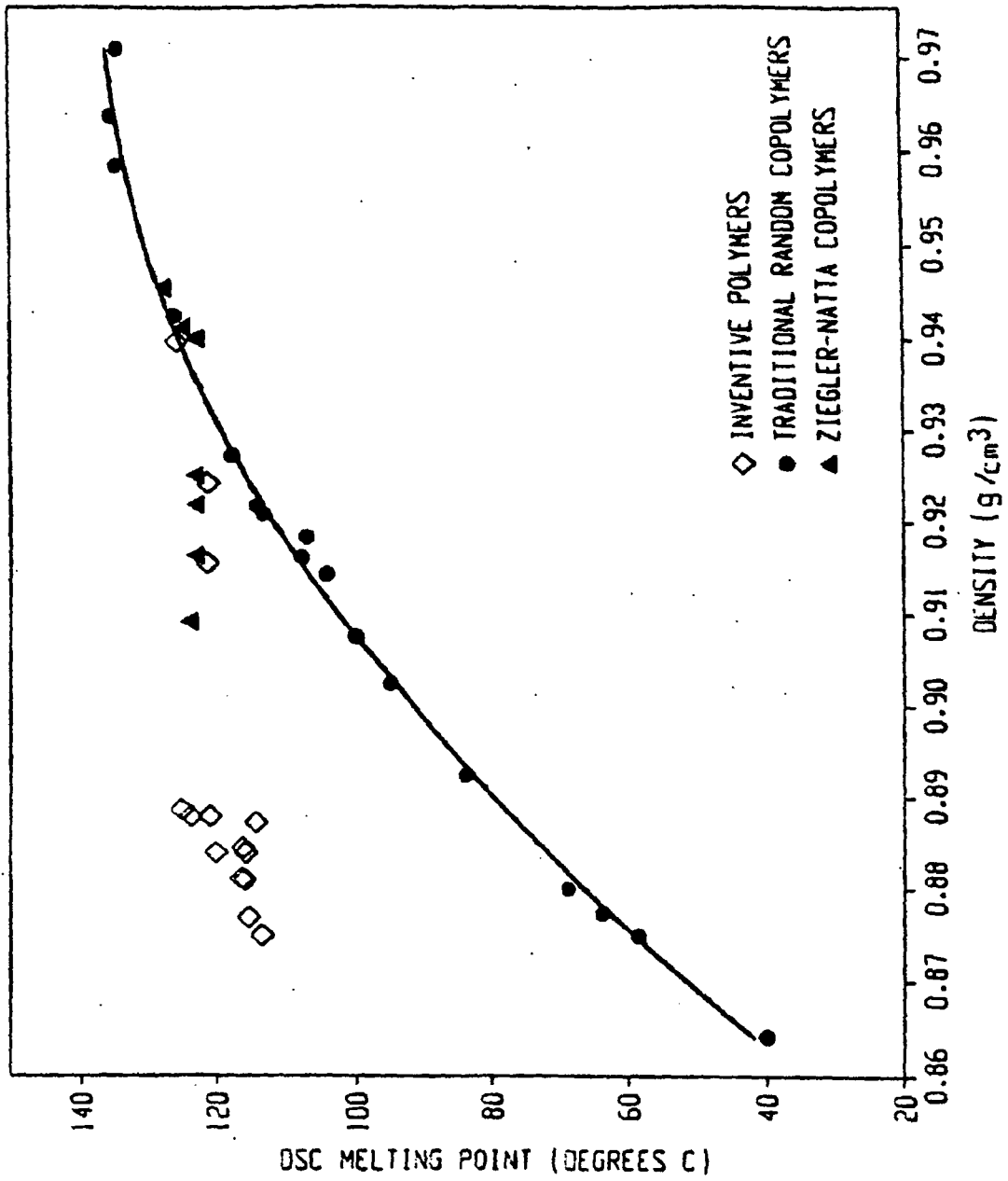

Fig. 1

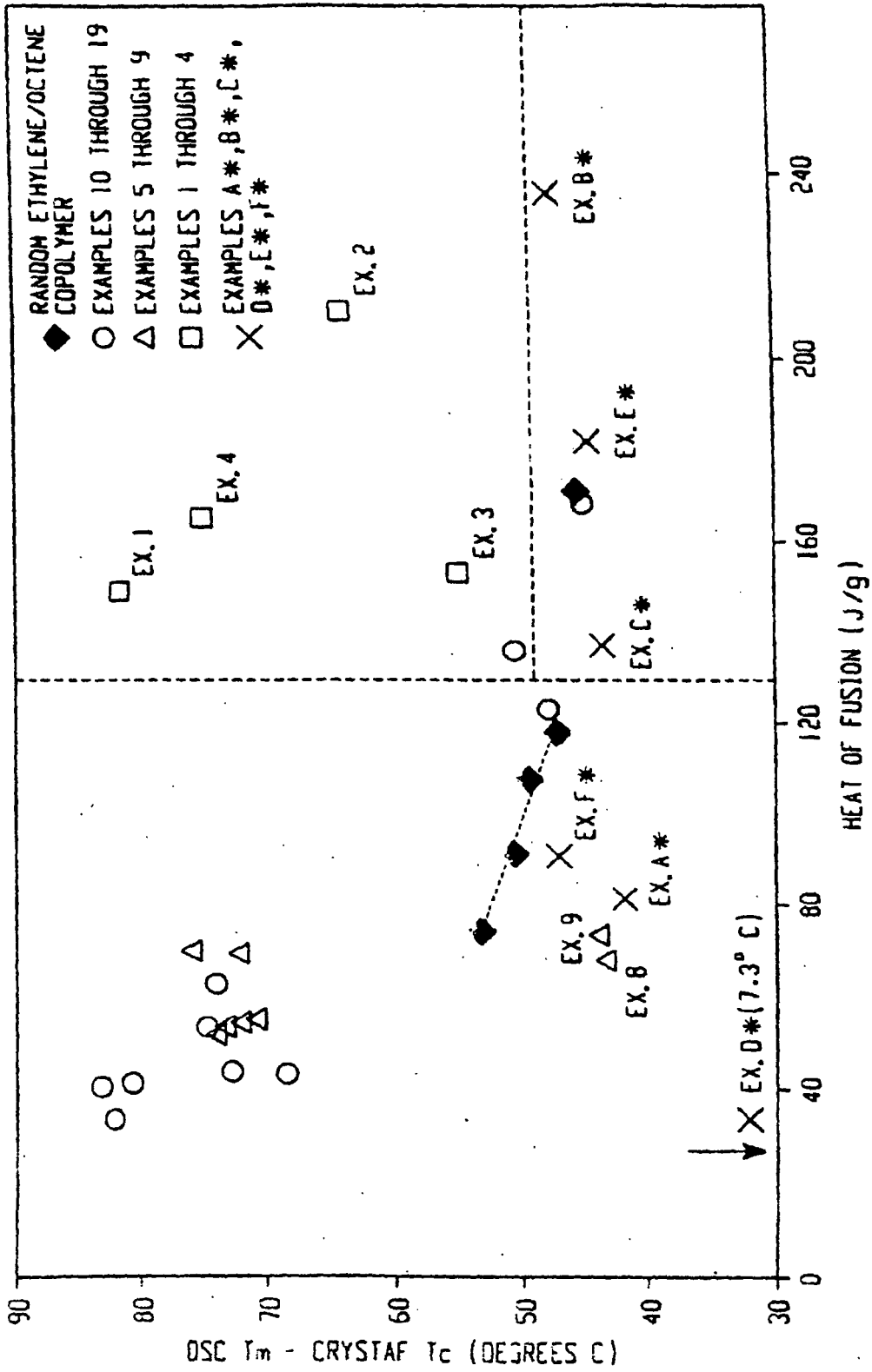

Fig. 2

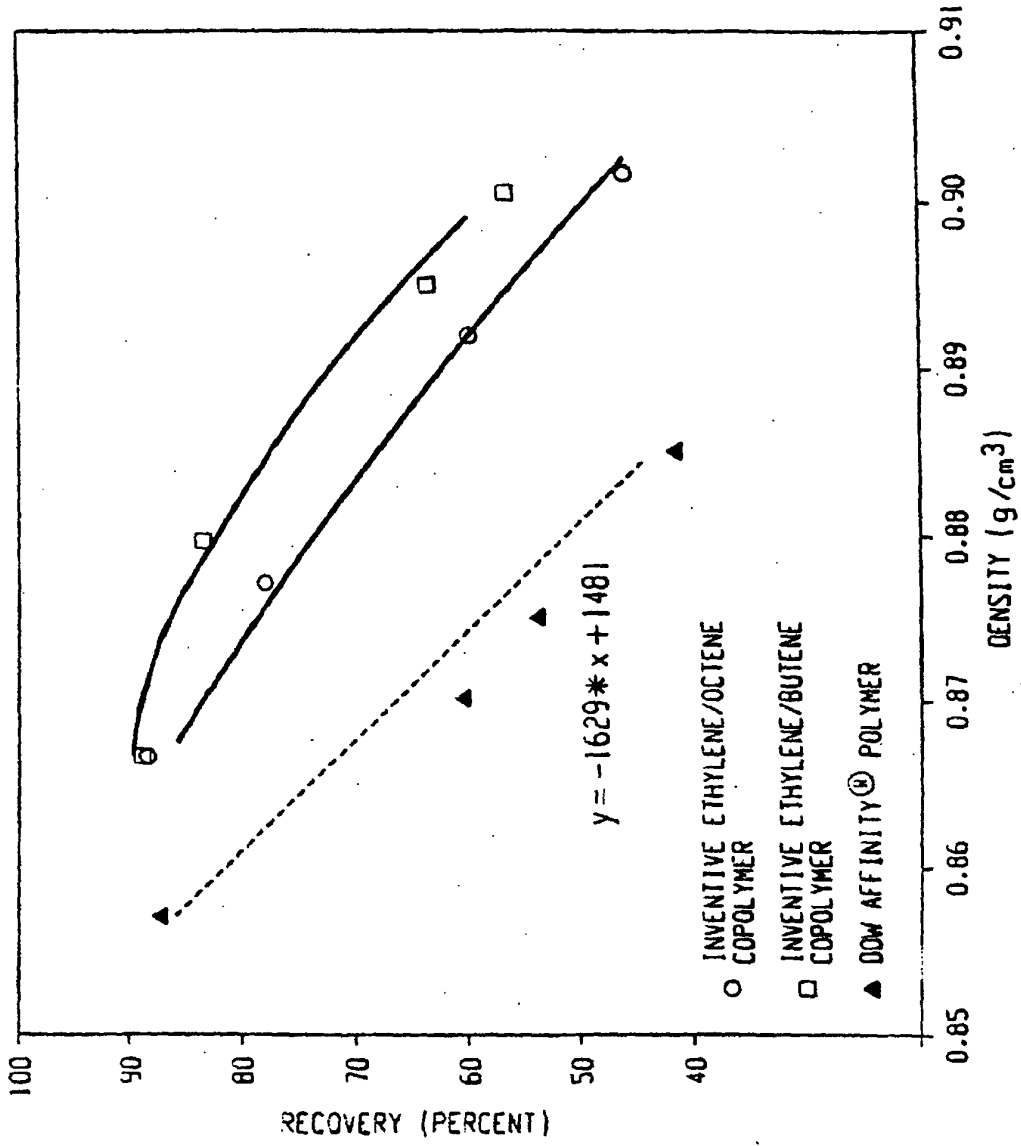

Fig. 3

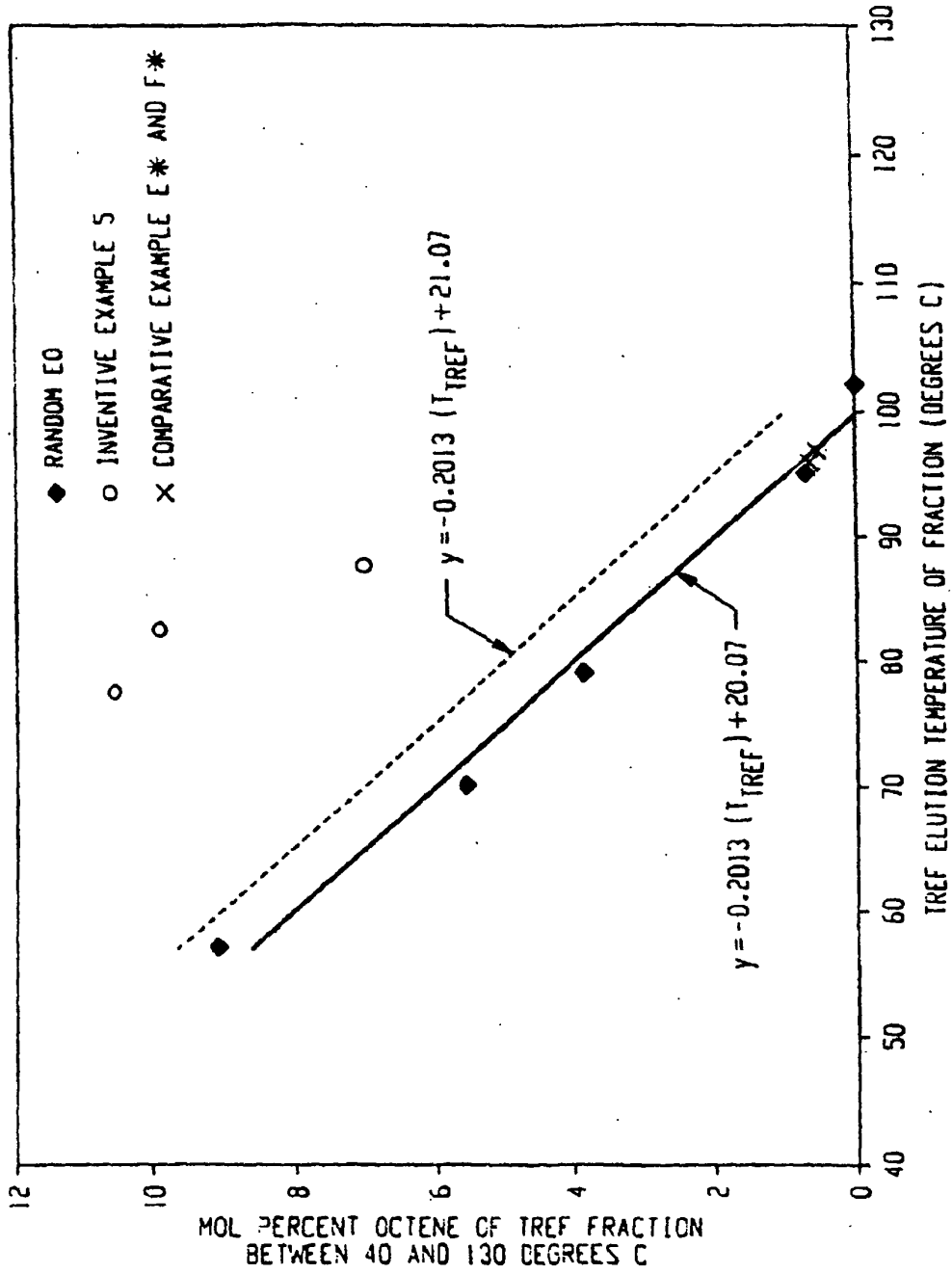

Fig. 4

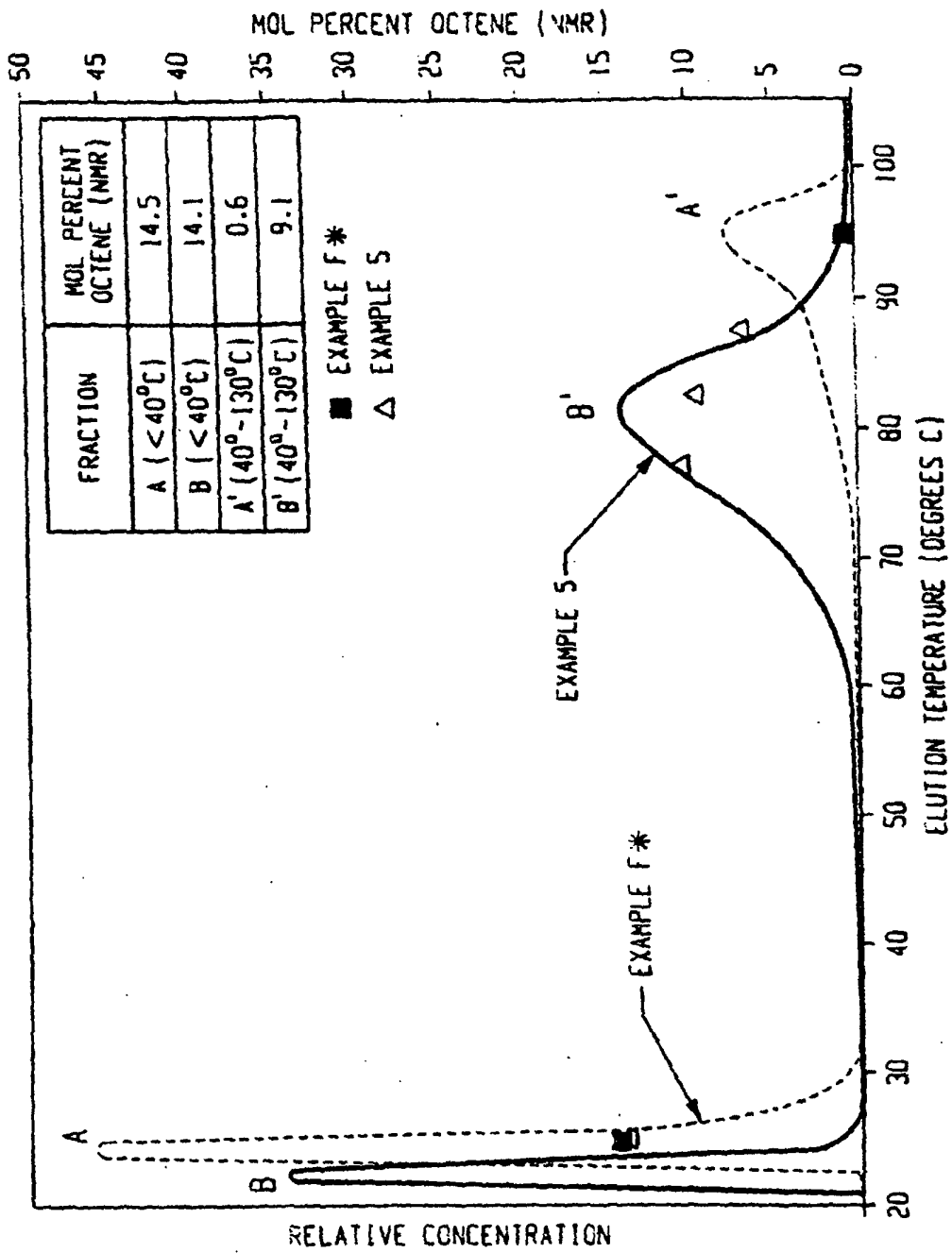

Fig. 5

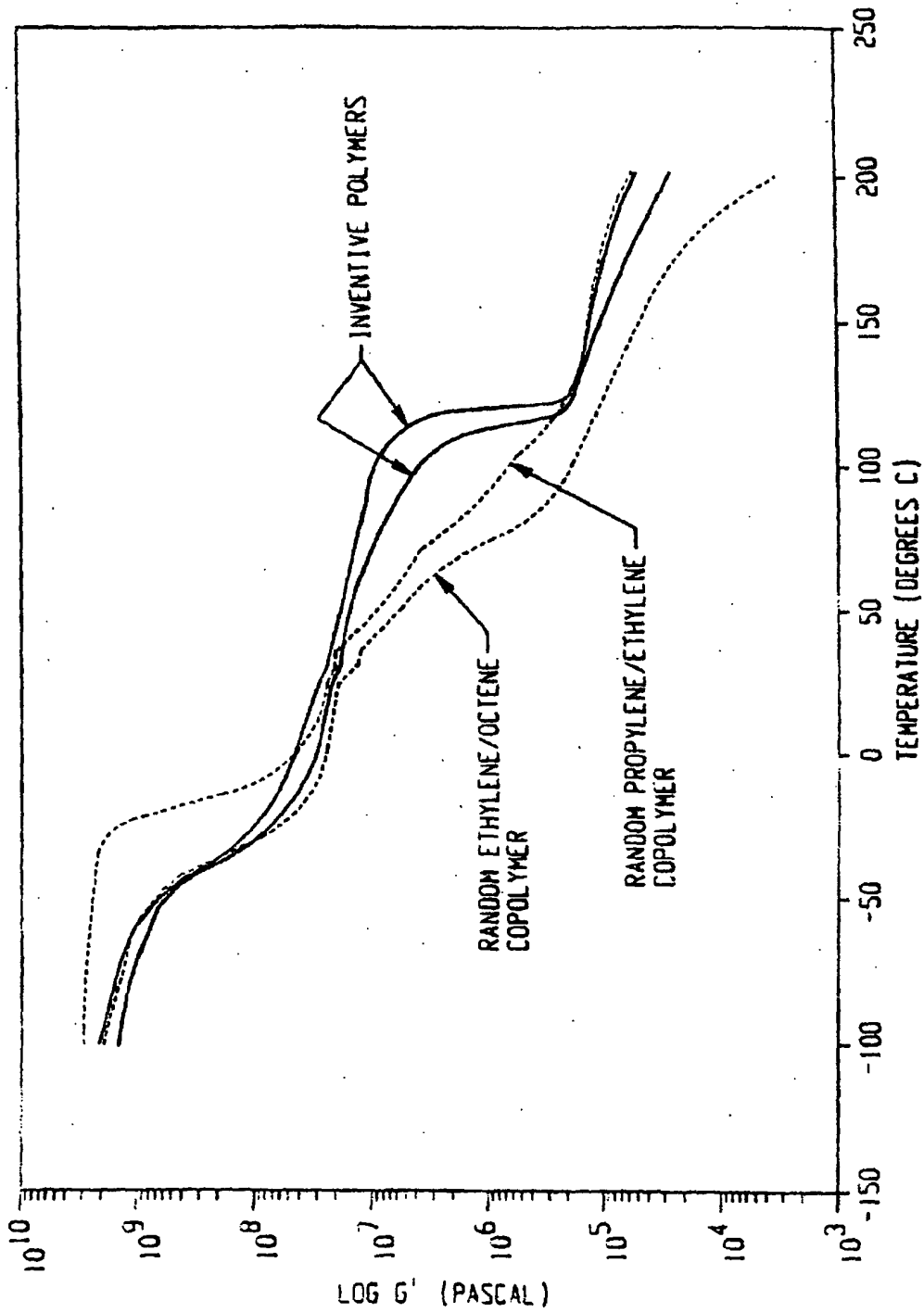

Fig. 6

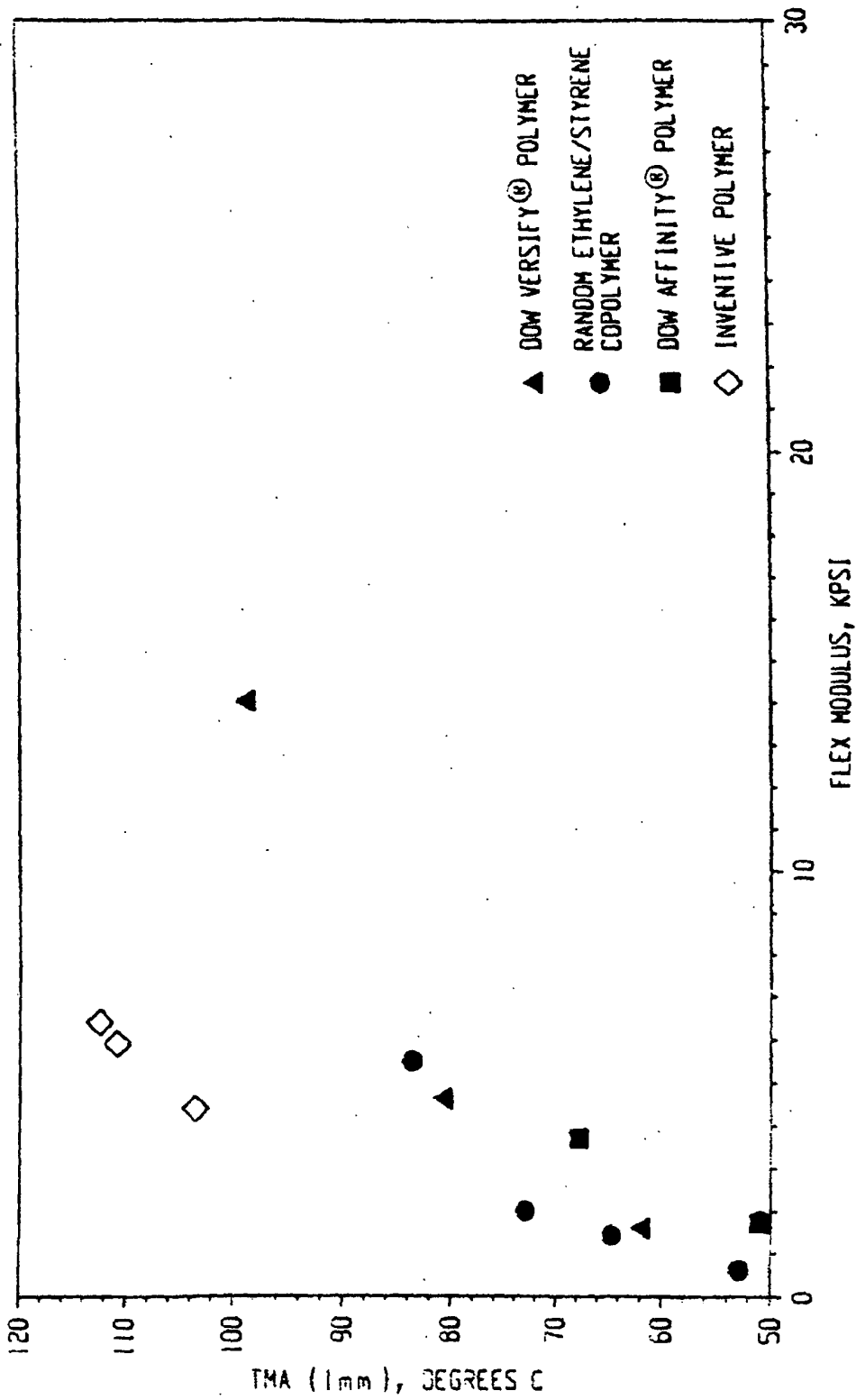

Fig. 7

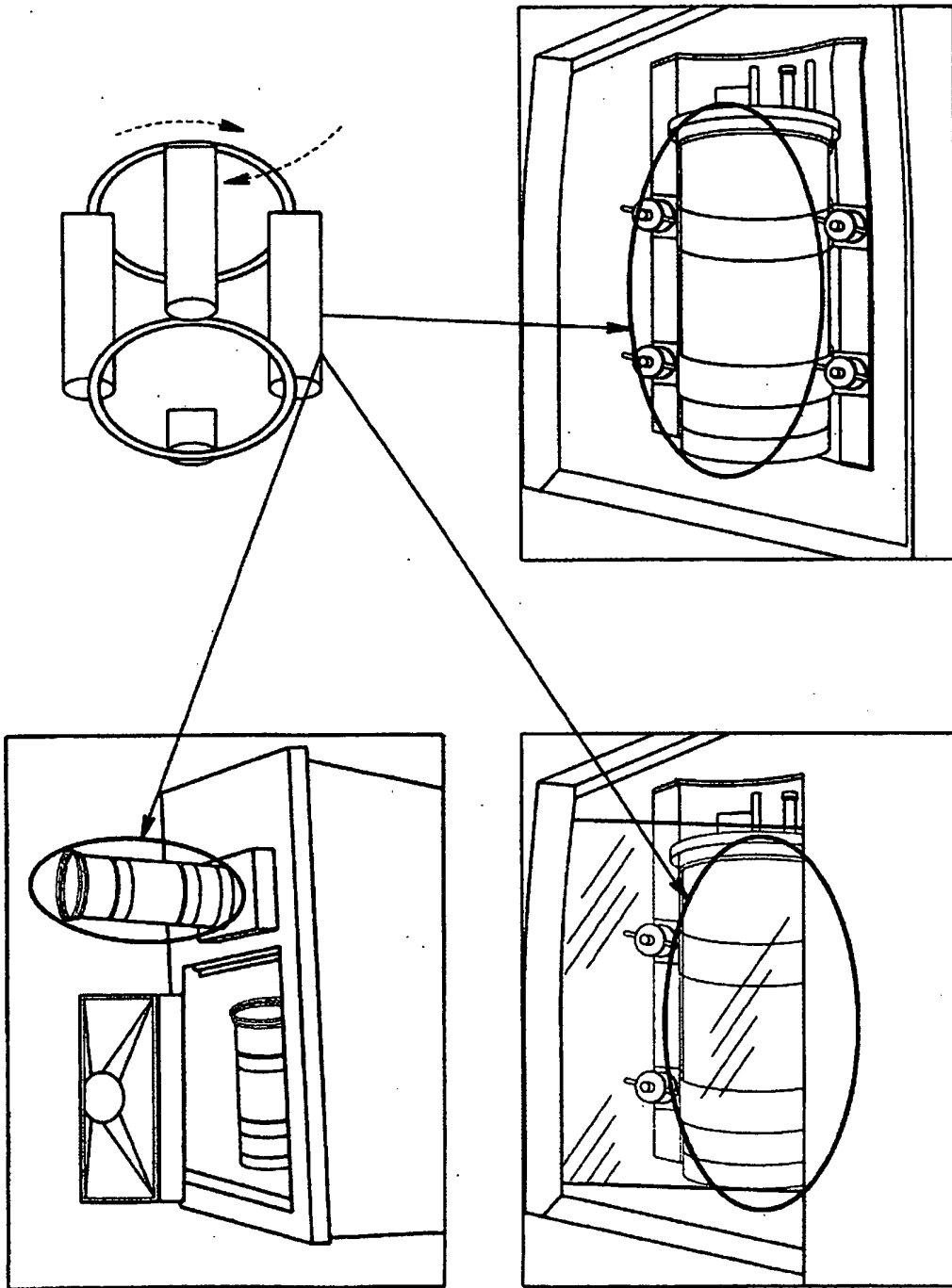

Fig. 8

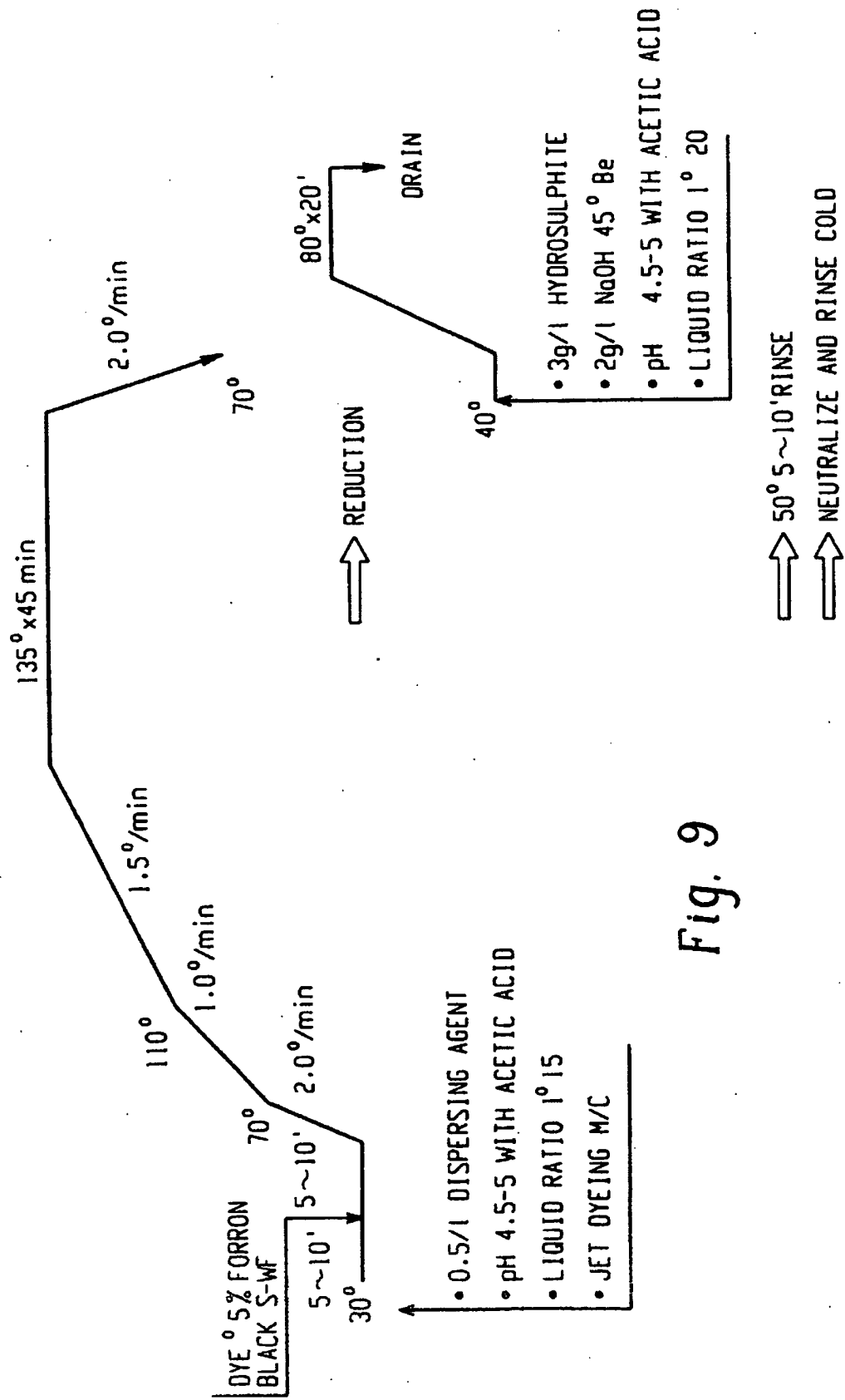

Fig. 9

REFERENCES CITED IN THE DESCRIPTION

This list of references cited by the applicant is for the reader's convenience only. It does not form part of the European patent document. Even though great care has been taken in compiling the references, errors or omissions cannot be excluded and the EPO disclaims all liability in this regard.

Patent documents cited in the description

- WO 2006102149 A [0002]
- US 6225243 B [0019]
- US 6140442 A [0019]
- US 5382400 A [0019]
- US 5336552 A [0019]
- US 5108820 A [0019]
- US 376835 A [0031]
- US 55390604 P [0076]
- US 66293705 P [0076]
- US 66293905 P [0076]
- US 66293805 P [0076]
- US 2005008916 W [0076]
- US 2005008915 W [0076]
- US 2005008917 W [0076]
- WO 03401952003 A [0078] [0079]
- US 0204017 A [0078] [0079]
- US SN10429024 A [0078] [0079]
- WO 0424740 A [0078] [0079]
- US 20040010103 A [0081]
- US P6268444 A [0084]
- US 2003004286 A [0085] [0086]
- US 4762890 A [0102]
- US 4927888 A [0102]
- US 4950541 A [0102]
- US 4798081 A [0130]
- US P59199883 A [0143]
- US P6395671 A [0144]
- US 6248540 B [0146]
- US 6030917 A [0146]
- US 6362309 B [0146]
- US 6306658 B [0146]
- US 6316663 B [0146]
- US 4340563 A [0202]
- US 4663220 A [0202]
- US 4668566 A [0202]
- US 4322027 A [0202]
- US 44131101 B [0202]
- US 3039895 A [0208]
- US 6652599 B [0208]
- US 20030024052 A [0208]
- US 3296063 A [0208]
- US 4999120 A [0208]
- US 933721 A [0208]
- US 20050142360 A [0208]

Non-patent literature cited in the description

- **Markovich, Ronald P. ; Hazlitt, Lonnie G. ; Smith, Linley.** Development of gel-permeation chromatography-Fourier transform infrared spectroscopy for characterization of ethylene-based polyolefin copolymers. *Polymeric Materials Science and Engineering*, 1991, vol. 65, 98-100 [0064]
- **Deslauriers, P.J. ; Rohlfing, D.C. ; Shieh, E.T.** Quantifying short chain branching microstructures in ethylene-1-olefin copolymers using size exclusion chromatography and Fourier transform infrared spectroscopy (SEC-FTIR). *Polymer*, 2002, vol. 43, 59-170 [0064]
- **Williams ; Ward.** *J. Polym. Sci., Polym. Let.*, 1968, vol. 6., 621 [0112]
- **Wilde, L. ; Ryle, T.R. ; Knobloch, D.G. ; Peat, I.R.** Determination of Branching Distributions in Polyethylene and Ethylene Copolymers. *J. Polym. Sci.*, 1982, vol. 20, 441-d55 [0130]
- **Randall, J.C.** *JMS-Rev. Macromol. Chem. Phys.*, 1989, vol. C29, 201-317 [0131]
- **Bamberg Meisenbach.** *Circular Knitting: Technology Process, Structures, Yarns, Quality*, 1995 [0205]
- **Garry Mock.** *Fundamentals of Dyeing and Printing*, 2002, ISBN 9780000033871 [0219]