



INTERNATIONAL APPLICATION PUBLISHED UNDER THE PATENT COOPERATION TREATY (PCT)

(51) International Patent Classification ⁶ : H04N	A2	(11) International Publication Number: WO 98/15111 (43) International Publication Date: 9 April 1998 (09.04.98)
(21) International Application Number: PCT/US97/16527 (22) International Filing Date: 17 September 1997 (17.09.97) (30) Priority Data: 08/715,296 17 September 1996 (17.09.96) US (71)(72) Applicant and Inventor: STAHL, Thomas, D. [US/US]; 2 Acorn Street, Portola Valley, CA 94028 (US). (74) Agents: MOGA, Thomas, T. et al.; Harness, Dickey & Pierce, P.L.C., Suite 400, 5445 Corporate Drive, Troy, MI 48098 (US).		(81) Designated States: AL, AM, AT, AU, AZ, BA, BB, BG, BR, BY, CA, CH, CN, CU, CZ, DE, DK, EE, ES, FI, GB, GE, GH, HU, IL, IS, JP, KE, KG, KP, KR, KZ, LC, LK, LR, LS, LT, LU, LV, MD, MG, MK, MN, MW, MX, NO, NZ, PL, PT, RO, RU, SD, SE, SG, SI, SK, SL, TJ, TM, TR, TT, UA, UG, US, UZ, VN, YU, ZW, ARIPO patent (GH, KE, LS, MW, SD, SZ, UG, ZW), European patent (AT, BE, CH, DE, DK, ES, FI, FR, GB, GR, IE, IT, LU, MC, NL, PT, SE), OAPI patent (BF, BJ, CF, CG, CI, CM, GA, GN, ML, MR, NE, SN, TD, TG). Published <i>Without international search report and to be republished upon receipt of that report.</i>
(54) Title: PIXEL COMPENSATED ELECTRO-OPTICAL DISPLAY SYSTEM		
(57) Abstract <p>A pixel compensated electro-optical display system utilizing a pixel compensator to correct image problems. The pixel compensator comprises pixels having elongated geometric shapes that compensate for distortions normally occurring in optical systems utilizing one or more reflective surfaces. The pixels are configured so that when the image plane is viewed at a particular angle, the image is substantially corrected without complex optical refiguring. The pixel compensated electro-optical display system of the present invention accordingly minimizes the need to correct the reflected image. The optical system of the present invention finds utility in applications that require a reflected image because of spatial and other constrictions. The optical system of the present invention finds particular application in vehicle "heads up" display systems as well as in virtual reality and total immersion display systems.</p>		

FOR THE PURPOSES OF INFORMATION ONLY

Codes used to identify States party to the PCT on the front pages of pamphlets publishing international applications under the PCT.

AL	Albania	ES	Spain	LS	Lesotho	SI	Slovenia
AM	Armenia	FI	Finland	LT	Lithuania	SK	Slovakia
AT	Austria	FR	France	LU	Luxembourg	SN	Senegal
AU	Australia	GA	Gabon	LV	Latvia	SZ	Swaziland
AZ	Azerbaijan	GB	United Kingdom	MC	Monaco	TD	Chad
BA	Bosnia and Herzegovina	GE	Georgia	MD	Republic of Moldova	TG	Togo
BB	Barbados	GH	Ghana	MG	Madagascar	TJ	Tajikistan
BE	Belgium	GN	Guinea	MK	The former Yugoslav Republic of Macedonia	TM	Turkmenistan
BF	Burkina Faso	GR	Greece			TR	Turkey
BG	Bulgaria	HU	Hungary	ML	Mali	TT	Trinidad and Tobago
BJ	Benin	IE	Ireland	MN	Mongolia	UA	Ukraine
BR	Brazil	IL	Israel	MR	Mauritania	UG	Uganda
BY	Belarus	IS	Iceland	MW	Malawi	US	United States of America
CA	Canada	IT	Italy	MX	Mexico	UZ	Uzbekistan
CF	Central African Republic	JP	Japan	NE	Niger	VN	Viet Nam
CG	Congo	KE	Kenya	NL	Netherlands	YU	Yugoslavia
CH	Switzerland	KG	Kyrgyzstan	NO	Norway	ZW	Zimbabwe
CI	Côte d'Ivoire	KP	Democratic People's Republic of Korea	NZ	New Zealand		
CM	Cameroon			PL	Poland		
CN	China	KR	Republic of Korea	PT	Portugal		
CU	Cuba	KZ	Kazakstan	RO	Romania		
CZ	Czech Republic	LC	Saint Lucia	RU	Russian Federation		
DE	Germany	LI	Liechtenstein	SD	Sudan		
DK	Denmark	LK	Sri Lanka	SE	Sweden		
EE	Estonia	LR	Liberia	SG	Singapore		

PIXEL-COMPENSATED ELECTRO-OPTICAL DISPLAY SYSTEM

Background of the Invention

I. Field of the Invention:

The present invention relates generally to reflecting image planes
5 used in optical applications. More particularly, the present invention
relates to a pixel compensated electro-optical display system. The display
includes a light source, a pixel compensator, and a first surface mirror.

II. Description of the Prior Art:

Image distortions are routinely encountered in typical video
10 projection systems. This is because most video projection systems require,
somewhere along the projection route, the use of a reflective plane of
some type to provide a compact system by reducing the total length
needed for the image projection to be made. For example, in large-screen
television projectors, a series of reflective surfaces are used to allow for the
15 compact construction of the projection system itself. The significant
distortions are caused by the fact that the object, for example, the
projected CRT image, and the projection screen are not themselves
parallel. The same problem arises in any projection system that relies on

a reflected image, such systems including television projection, high definition television projections, and in almost all audio-visual applications.

The problem of distorted video projections has traditionally been approached in such a way that requires the use of relatively complex
5 lensing and optical systems. The image distortions that are introduced by the optical geometry of the typical projection system have not historically been of significant concern because the picture quality has generally been held to be acceptable. However, more lately, data and video projectors have been developed to specifically display computer generated video
10 information. In such applications, the video image distortions are not merely annoying, but are, in fact, critical flaws in such projection systems.

Typical distortions encountered in projection television systems include non-uniform focus, keystone distortion, and vertical and horizontal non-linearity. Each of these distortions results from the fact that the image
15 source, that is, the projector and the display screen, are not parallel. This occurs where a projector image source is off the central optic axis and is known as horizontal displacement. (See "Image Distortions in Video Projection", Dennis W. Vance, Vertex Video Systems publication.) Both horizontal displacement and vertical displacement exist in the typical 3-tube
20 color projecting unit. Such displacements result in the distortions mentioned above.

The first of these distortions, non-uniform focus, results from the non-horizontal placement of the projector with respect to the screen because only one part or the other of the image on the screen may be focused while the other remains out of focus. This is true because the focal length between the projector and the image is not constant. Conventionally, non-uniform focus has been corrected by using a fairly complex system of lenses disposed between the projector and the screen.

The two remaining types of distortions, keystone distortion and distortions related to non-linearity, are the result of image geometry. This is based on the fact that a projector and an image screen, when not parallel, result in magnification of the image being varied along the direction of the tilted plane. This distortion still remains, even after the interdisposition of a lens between the projector and the screen. Two types of distortions result from the magnification problem, the first of which is called keystone distortion and the second of which is called vertical non-linearity. Keystone distortion results in variation of the horizontal magnification, while vertical non-linearity distortion results in variation in the vertical magnification.

Traditionally, efforts to correct these distortions have been made both electronically and optically. Electronic corrections include the pre-distorting of the primary image, and this approach has been taken typically

where CRT's and light-addressed light valves are employed. The modification of the optical system has conventionally been taken where matrix-addressed light valves are employed. The correction of the distortions is extremely expensive and often produces enormously complex electronic and optical corrections systems. This is because the conventional approach has been to correct not the projection system, but the optics themselves.

Summary of the Present Invention

The present invention provides a reflecting image plane which overcomes the above-mentioned disadvantages.

In brief, the present invention comprises an electro-optical display system that provides an image without distortion. This is accomplished by a pixel compensated display that includes a light source, a pixel compensator (mounted either fixedly at a 45° angle or mounted pivotably), a first surface mirror, and a projection screen. The final image is free from distortion. The pixel compensator may be characterized as active, passive, or a straight passive (with simple lines), and may be composed of various materials including a single crystal silicon, an amorphous silicon, or a polysilicon.

The pixel compensated electro-optical display system of the present invention resolves a number of optical problems. For example, stigmatism is eliminated by proper alignment of the first surface mirror with respect to the pixel compensator.

5 The system may be used in conjunction with any flat projection system or any active matrix system, or any system that utilizes a light valve approach to projection. The system may be used in combination with television, high definition television, or any similar CRT projection application. As noted, the optical system of the present invention
10 comprises a light projection source, a projection screen, and, disposed between the projection source and the screen, one or more (compound) lenses, a pixel compensator and a first surface mirror. The compensator and a first surface mirror comprise a reflective pixel structure, which serves as the primary compensator. The compensator acts as a mirror held at a
15 preferred 45° angle with respect to the projection source. This preferred angle may be modified to a greater or lesser angle (preferably within 4°) either way. (This small amount of movement would compensate for distortion similar to that seen in the display of an overhead projector lens that has been tipped too far in one direction.)

20 The pixel compensator itself is the compensating pixel structure. The plane compensates for the non-uniform focus, the keystone distortion,

and the vertical non-linearity distortions mentioned above by using an appropriate pixel configuration. Preferably, the pixel configuration is an elongated or a rectangular pixel construction which performs the compensation. A first surface mirror receives the image from the pixel
5 compensator and reflects it onto a projection screen. The first surface mirror corrects for stigmatism and blooming.

The system of the present invention produces an image that requires little, if any, correction. That correction which is required can be made by single, double, or triple lens systems, rather than by the complex
10 lensing conventionally found in correcting light valve projection systems.

The projection system of the present invention also does away with the complex masking also conventionally found in present projection systems.

The present system finds utility in virtually any projection system in
15 which space is limited, thus requiring off-axis projection. Of course, while the preferred angle may be 45° , the pixel configuration of the image plane of the present invention can be modified in virtually unlimited ways to compensate for almost any angle greater or lesser than the preferred 45° angle.

20 Anticipated applications of the optical system of the present invention include use in vehicle "heads-up" systems. The vehicle may be

air, water, or land based vehicles. The projection system may be used to project onto the windshield for viewer observation, or may be used to project onto a control monitoring screen for the driver. Additionally, the projection system may be a rear "heads-up" projection system which projects onto the back window of a vehicle.

Additional uses of the pixel compensated electro-optical display system of the present invention include utility as a projection system for virtual reality head gear and also in "Total Immersion" systems which provide the user with "wrap-around" video display.

10

Brief Description of the Drawings

A better understanding of the present invention will be had upon reference to the following detailed description when read in conjunction with the accompanying drawings in which like reference characters refer to like parts throughout the several views, and in which:

15

FIG. 1 is a view illustrating the basic and known optical system;

FIG. 2 is a view illustrating the general layout of the optical system of the present invention incorporating the image plane with the compensating pixel structure:

20

FIG. 3 is a view of the reflecting image display plane of the present invention illustrating the approximate shapes of the pixels as they would

appear when the image plane is viewed without any edges being angled away from the viewer:

FIG. 4 is a variation of the surface configuration of the reflecting image display plane of Figure 3;

5 FIG. 5 is an additional variation of the surface configuration of the reflecting image display plane of Figure 3:

FIG. 6 is a cross-sectional view of a preferred pixel according to the present invention:

10 FIG. 7 is a cross-sectional view of an alternative pixel according to the present invention:

FIG. 8 is a dichroic system that provides an additional method of polarizing light according to the present invention:

FIG. 9 is a view of the reflecting image display plane of Figure 3 when the plane is tilted at a 45° angle with respect to the viewer;

15 FIG. 10 is a sectional view of a vehicle's driver compartment and illustrating uses of the image plane of the present invention in conjunction with optical systems:

FIG. 11 is a top sectional view of a virtual reality mask illustrating the positioning of the image plane of the present invention in conjunction
20 with optical systems:

The system comprises a bulb 12, a layer of heat absorbing glass 14, a condenser lens combination 16 (only a single lens is shown here for simplicity, but the condenser lens combination comprises a number of lenses), a color filter 18, and a first surface mirror 20. The system 10 also includes a PCX lens 20 (again this is a combination system), a reflecting image plane 24, a scatter mask 26, a columnating lens system 28, a dichroic combiner 30, and, most often, a zoom lens 32. Some variations of this system are known, but the variations commonly add to the lensing system beyond what is shown to the end of correcting optical distortions.

Figure 1 also generally illustrates the complexity of the known systems for correcting optical distortions in projection systems.

Figure 2 is a view illustrating the general layout of the optical system of the present invention generally illustrated as 34. The system 34 includes a light projection source 36, a pixel compensator 38, a first surface mirror 40 (to correct for stigmatism and blooming), and a projection surface 42.

The light projection source 36 is one of a number of columnated or polarized light sources. Conversely, the actual image is created on the pixel compensator 38. In the former situation, the source 36 would produce appropriate colors and the components of the pixel compensator would be clear or monochromatic. As an alternative to both systems, a

dichroic system could be employed that comprises a white light source and a number of pixel compensators.

One or more condensing lenses 37 may be fitted to the projection source 36. The lens 37 may be a single lens or may be an array of
5 compound lenses.

The source 36 may produce either a white light or a plurality of selected colors. The source 36 may be colored by use of conventional color-coated bulbs or painted or coated LED's. Alternatively, the source 36 may be colored by filtering techniques such as a color wheel. More
10 particularly, the source 36 may comprise a number of L.E.D.'s of the colors red, green and blue that are strobed prior to projection onto the compensator 38. Alternatively, the source 36 might comprise surface mode L.C.D.'s or ferroelectric liquid crystals. (The ferroelectric liquid crystals offer the advantage of being of a higher speed range that can
15 accommodate strobing. This makes them a superior choice over, for example, N-CAP or P.D.L.C.'s [polymer dispersed liquid crystals].)

At the heart of the system of the present invention is the pixel compensator 38. This face of the compensator 38 is shown in detail in Figures 3 and 4. The compensator may either be fixedly mounted at a
20 preferred angle of 45° or may be pivotably mounted. (The pivoted

mounting allows for an additional degree of movement one way or the other to, for example, 4° in either direction.)

The optical system of the present invention as presented in Figure 2 is based on the image plane design and not through optical correction.

5 The system is based upon Snell's Law theory which is used to achieve a perfectly undistorted image. This is true as applied to the system 34 whether in the HDTV format, NTSC format, 3:4 aspect ratio, or 9:16 aspect ratio. Once the compensator 38 and its pixels are configured correctly, the system can be applied to virtually any optical use.

10 With reference to Figure 3, a front view of the pixel compensator 38 is illustrated as the approximate shapes of the individual pixels 44 are viewed straight on without any edges of the compensator 38 being angled away from the viewer. As illustrated, the individual pixels 44 have a rectangular shape, although the shape may well be varied depending on

15 the angle of the compensator 38 with respect to the light source and the projection surface. Some of the possible variations are illustrated in Figures 4 and 5 which illustrate alternate embodiments of the pixel configuration. Several variations may be possible, provided the individual cells comprise any elongated packing-cell type of configuration. If color

20 production is the compensator-pixel type, certain pixels may provide red color (designated "R"), others may provide blue color (designated "B"),

while still others may provide green color (designated "G"). This layout is illustrated in Figures 4 and 5.

As noted, to provide defined colors, either the pixel compensator 38 would introduce defined colors (for example, red, green, and blue) into the system or the defined colors would be introduced by the source 36. A further embodiment, a dichroic system, is also possible and will be discussed below with respect to Figure 8.

Where the pixel compensated display of the present invention requires that the pixel compensator 38 provide color because the source 36 does not provide color, then the pixels 44 would be constructed so as to provide the necessary color. There are a number of ways this may be accomplished. One such construction, and with respect to Figure 6, is fairly simple and includes a pixel 44' comprising a pixel pad 39 having a colored layer 41 (red, green, or blue) disposed directly on the upper surface of the pad 39.

Another construction is illustrated in Figure 7, and illustrates a pixel 44'' that comprises a pad 39', a color layer 41', and an upper glass layer 43. According to this latter construction, the upper level of the pixel pad 39' is a reflective surface. Light produced by the source 36 passes through the glass layer 43 to reflect off of the pixel pad 39', and taking on the color of the color layer 41' in the process.

Where the colors are provided by the source, the system would include one or more polarizers for color definition. This is illustrated in Figure 2 and includes a polarizer 45 disposed between the source 36 and the plate 38. A second polarizer 47 is optionally disposed between the plate 38 and the first surface mirror 40. With the polarizers 45, 47 in place, the light emitted by the source 36 would be defined before striking the plate 38. Additionally, and as provided for by the second polarizer 47, the image coming from the plate 38 would be further polarized.

An additional method of polarizing - a dichroic system - is illustrated in Figure 8. According to this system, light is emitted from the source 36 and is received - undefined - onto the plate 38. The reflected light strikes a first pixel compensated display 49, and all colors are reflected by the display. The reflected image then strikes a first dichroic plate 51 that allows, for example, green and red light to pass, but reflects blue light. The blue light then strikes and is reflected by a first surface mirror 53 and, after passing through selectively transmissive mirrors 61, 65, strikes and appears on a screen 55.

The green and red light passing through the first dichroic plate 51 strikes and is reflected by a second pixel compensated display 57, and both colors are reflected by the display. The reflected image then strikes a second dichroic plate 59 that allows, again by way of example, green light

to pass, but reflects red light. The green light then strikes and is reflected by the selectively transmissive mirror 61 and, after passing through the selectively transmissive mirror 65, strikes and appears on the screen 55.

The remaining red light strikes a third pixel compensated display 63
5 and is reflected thereby onto the selectively transmissive mirror 65 which, in turn, reflects the red light onto the screen 55.

Alternative methods of providing colors (not shown) include technologies that relate to rapidly spinning color wheels, strobing, and pie cell techniques (the latter being an additive process which, for example,
10 substitutes a non-red, green, blue color such as magenta for the basic colors and achieves a red, green or blue color).

Figure 9 illustrates a view of the pixel compensator 38 when tilted to approximately a 45° angle as it would appear to either the light projection source or the projection surface 42. As can be seen, the
15 elongated shape of the individual pixels is "corrected" and appears to be a conventionally-shaped square. With the possible exception of minor correction, no further correction of the image is necessary, as most (if not all) distortions may be eliminated by proper configuring of the display plane.

20 Figure 10 is a sectional view of a vehicle driver's compartment, generally illustrated as 46. The compartment 46 includes a dash panel 48

and a windshield 50. The compartment 46 may be from a land vehicle, or may be from water or air vehicles as well. Applications are also envisioned for use in space vehicles where restricted room is notorious.

Two display systems of the present invention are shown. The first
5 is an in-dash system, generally illustrated as 52. The in-dash system 52 includes a dash panel 54, a light projection source 56, a first surface mirror 58, and a pixel compensator 57. The image projected to the back of the dash panel 54 is visible to the driver (not shown) on the front (driver-facing) side of the panel 54.

10 The second display system of the present invention shown in Figure 10 is a "heads up" system, generally illustrated as 60. The "heads up" system 60 is designed to project pertinent information directly onto the compartment (driver-facing) side of the windshield 50. The title of this system is derived from the fact that the driver need not refer to the dash
15 board for information, but rather fix attention only to the windshield. This has particular strategic application in fighter aircraft.

The "heads up" system 60 includes a light projection source 62, a pixel compensator 63, and a first surface mirror 64. The compartment side of the windshield 50 acts as the projection screen.

20 Figures 11 through 13 relate to a head mounted display device for use with a virtual reality system. The reflective image display plane of the

present invention finds particular application with this technology because of the constricted space available for the projection system.

With reference to Figure 11, a top sectional view of a head mounted display device is illustrated, generally shown as 70. The display device 70 includes a frame 72 having a pair of head temple arms 74, 74' and a front piece 76. The frame 72 may be composed of about any polymerized material that is light weight and durable. The light weight is an important factor, else the user would tire quickly of wearing the display device 70. A pair of built-in earphones (not shown) may be provided, and would preferably be suspended from each of the temple arms 74, 74' to fit in the ears of the user.

A left projection system 78 and a right projection system 78' are provided within two cavities 80, 80' defined in the frame 72. The systems 78, 78' are mirror images of each other. In all other respects the two systems 78, 78' are identical. Accordingly, only the left system 78 will be discussed in detail.

A light projection source 82 is provided off to one side or the other of the cavity 80. A pixel compensator 83 is provided adjacent to the source 82. A first surface mirror 84 is mounted within the cavity 80 at approximately a 55° angle, although a greater or lesser degree may be used

provided the shape of the pixels is appropriately configured. A first surface mirror 86 is included to redirect the image received from the mirror 84 onto the back side of a projection surface 88. The projection surface 88 would preferably be composed of a holographic diffuser or, alternatively, of a similar material such that the wearer (not shown) may view the produced image on a viewing side 90 of the device 70.

Figure 12 illustrates a sectional view taken through the side of an alternative embodiment of the head mounted display device of Figure 11. Figure 12 illustrates a device, generally shown as 92, that includes a frame 94 having a temple arm 96 and a front piece 98. A cavity 100 is defined within the front piece 98. Within the cavity 100 is disposed a light projection source 102, a pixel compensator 103, and a first surface mirror 104. A holographic projection surface 106 receives the image for viewing.

Figure 13 illustrates yet another alternate embodiment of the head mounted display device of Figure 11. The device of Figure 13, generally illustrated as 108, is a modified version of the head mounted display device that produces a holographic image for the wearer. Specifically, the device 108 comprises a frame 110 having a pair of temple arms 112, 112' and a front piece 114. Within the front piece 114 are defined a pair of cavities 116, 116'. The projection systems disposed within the cavities 116, 116' are identical, and hence only one system will be discussed in detail herein.

A first light projection source 118 is provided at one side of the cavity 116 and a second light projection source 120 is provided at another side of the cavity 116. A first surface mirror 122 conveys the light received from a pixel compensator 119 to a projection surface 124. A first surface
5 mirror 126 conveys the light received from pixel compensator 121 to the projection surface 124. (The projection sources 118, 120 do not interfere with the reflected images because they are positioned either above or below the planes of the reflected images.) The cumulative image produced on the projection surface 124 is perceived by the viewer (not shown) to be
10 a holographic image.

Figure 14 illustrates a sectional view of a full immersion holographic display system utilizing the optical system of the present invention, generally indicated as 130. The immersion display system 130 has many uses, including film viewing and for playing video arcade games. The
15 projection system of the system 130 is constructed so as to provide a "seamless" view to eliminate the edges commonly encountered in CRT screens.

To accomplish the holographic effect, a single projection surface 132 has two images being projected onto it simultaneously. An upper light
20 projection source 134 directs an image first to a pixel compensator 135, then to a lower first surface mirror 136 which, in turn, conveys the image

to the surface 132. A lower light projection source 138 directs a reversed image first to a pixel compensator 139, then to an upper first surface mirror 140, and, finally, to the projection surface 132. Because the images are reversed with respect to each other and are overlapping, a viewer 142
5 perceives the image produced on the viewing side of the surface 132 as being fully three-dimensional. The viewer 142 interprets the wrap-around screens (an opposite screen 144 is illustrated, but it should be understood that the viewer 142 is fully encompassed by the side screens) as being a viewing "bubble".

10 As a further variation of the display system of Figure 14, Figure 15 illustrates a more conventional projection system employing the pixel compensated display of the present invention. The display, generally indicated as 150, comprises a housing 152 and a number of internal components. These components include a source 154, a pixel compensator
15 156, a first surface mirror 158, an image reflecting and aligning mirror 160, and a rear projection screen 162. A viewer 142' views the projected image as illustrated.

Having described my invention, however, many modifications thereto will become apparent to those skilled in the art to which it pertains
20 without deviation from the spirit of the invention as defined by the scope of the appended claims.

I claim:

CLAIMS

1. A pixel compensated electro-optical display system for use in spatially constricted areas, said system comprising:
 - a light source;
 - at least one reflective image display plane, said plane comprising a
 - 5 plurality of pixels, each of said pixels having a front surface, said front surface of each of said pixels having a length and a width, said length of said front surface being greater than said width of said front surface;
 - a first surface mirror; and
 - at least one projection surface.
2. The display system of claim 1 wherein said front surface of each of said pixels has a rectangular shape.
3. The display system of claim 1 wherein said front surface of each of said pixels has a diamond shape.
4. The display system of claim 1 wherein each of said pixels has a long axis, said pixels being aligned so that said long axis of each pixel is parallel with each other pixels.

5. The display system of claim 1 further including a head mounted display unit.

6. The display system of claim 1 wherein said light source generates columnated light.

7. The display system of claim 1 wherein said light source generates polarized light.

8. The display system of claim 1 wherein said light source generates white light.

9. The display system of claim 1 wherein said light source generates colored light.

10. The display system of claim 9 further including a polarizer.

11. The display system of claim 1 wherein said light source is comprised of a plurality of light emitting diodes.

12. The display system of claim 8 wherein said plurality of diodes includes red, green and blue diodes.

13. The display system of claim 1 further include a plurality of dichroic plates and a plurality of said image display planes.

14. The display system of claim 1 further including a plurality of said projection surfaces.

15. The display system of claim 14 further including a structure having an internal space, said internal space being of such dimension to permit the entry of the head of a human, said structure having a peripheral wall, said plurality of projection surfaces being disposed on said peripheral
5 wall.

16. A pixel compensated electro-optical display system for use in spatially constricted areas, said system comprising:
a light projection source;
a reflective image display plane, said plane comprising a plurality of
5 pixels, each of said pixels having a length and a width, said length being greater than said width; and

a projection surface.

17. The display system of claim 16 further including a head mounted display unit, each of said light projection source, said reflective image display plane, and said projection surface being incorporated into said head mounted display unit.

18. A reflective image display plane for use in an optical system, said plane comprising:

a front imaging surface, said front imaging surface comprising a plurality of pixels, each of said pixels having long axis, said pixels being
5 aligned along their long axes.

19. The reflective image display plane of claim 18 wherein each of said pixels has at least four sides, at least one of said four sides having a length greater than at least one other of said four sides.

20. The reflective image display plane of claim 19 wherein the front imaging surface of each of said pixels is rectangularly shaped.

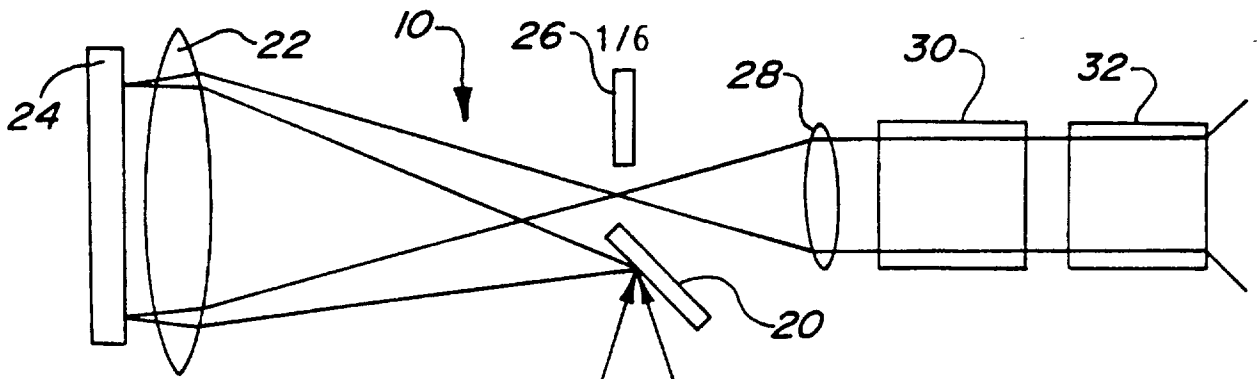

Fig - 1
PRIOR ART

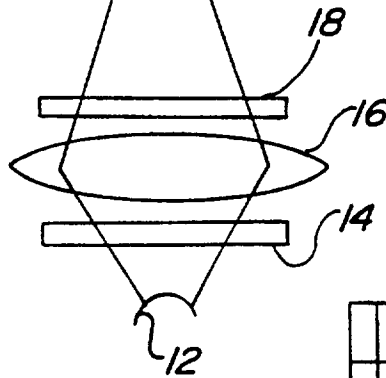

Fig - 3

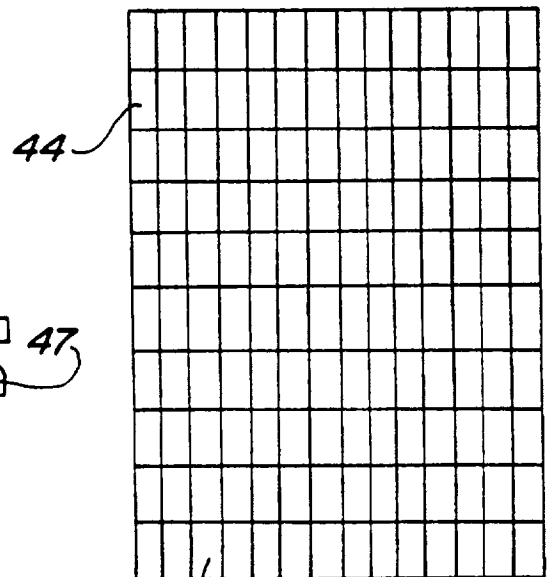

Fig - 2

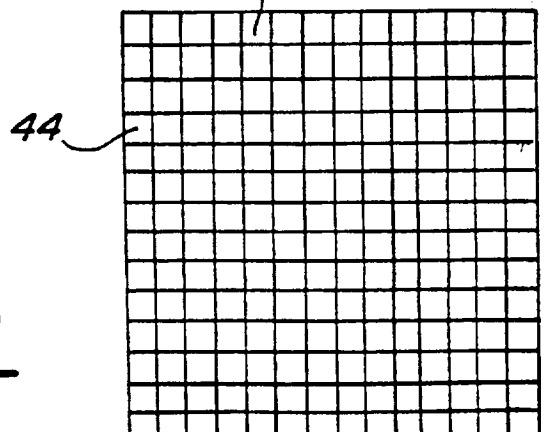
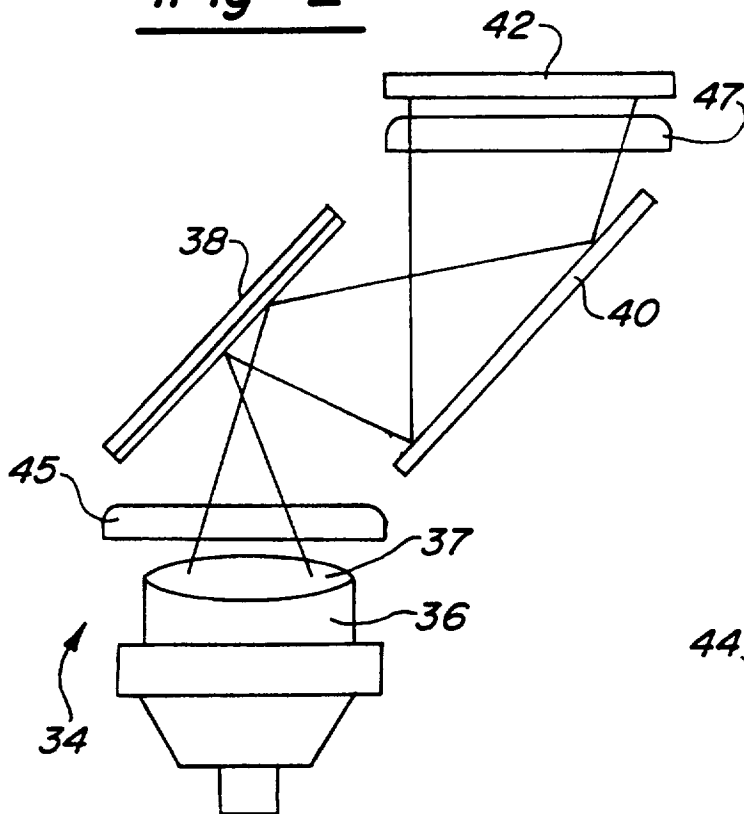

Fig - 9

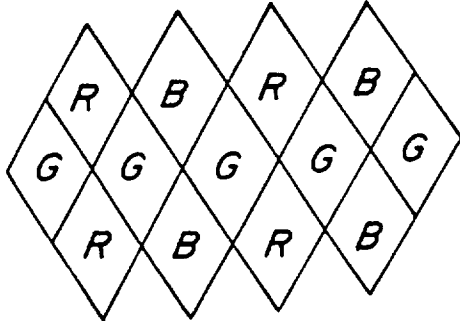

Fig - 4

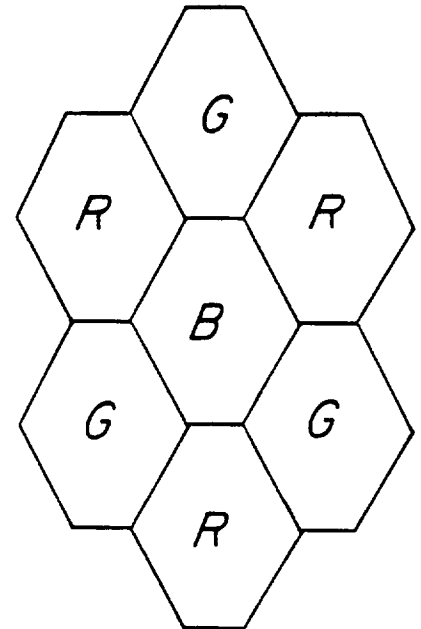

Fig - 5

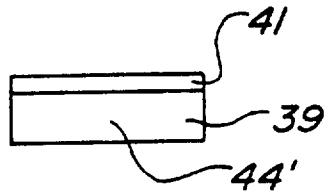

Fig - 6

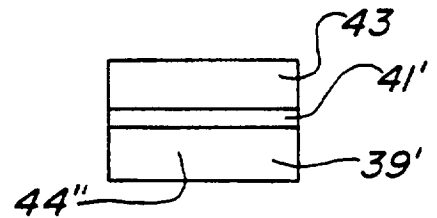

Fig - 7

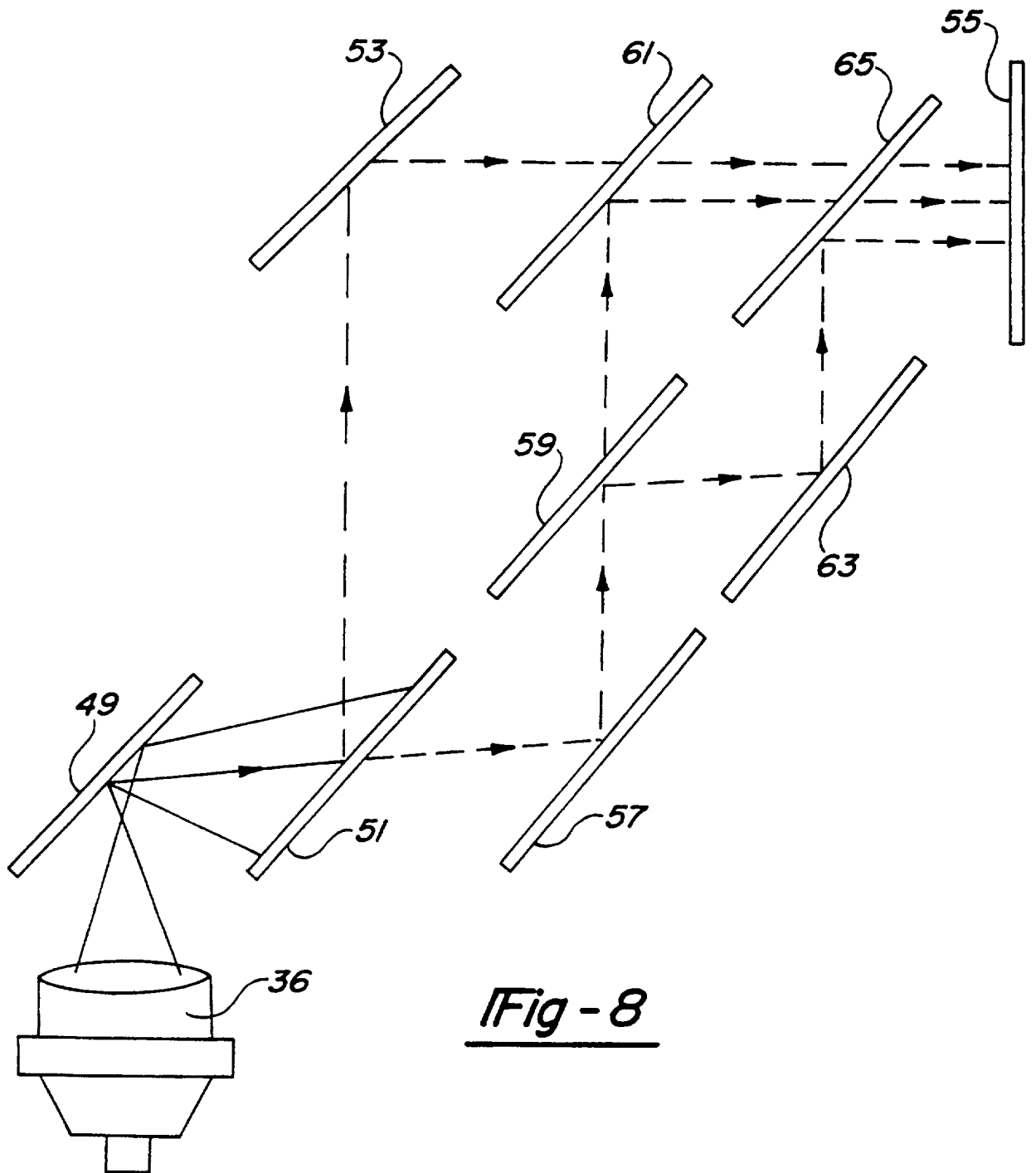

Fig - 8

Fig - 10

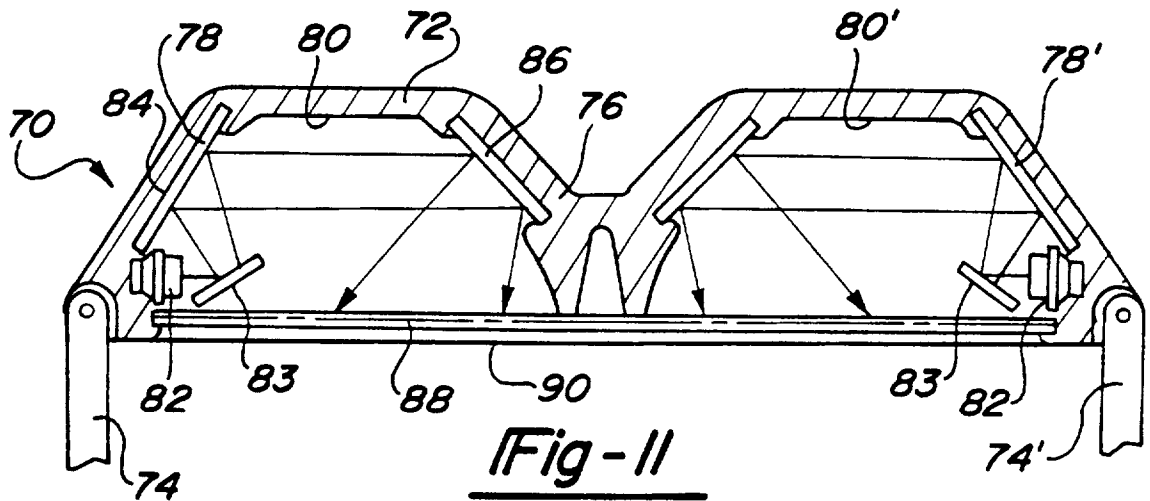
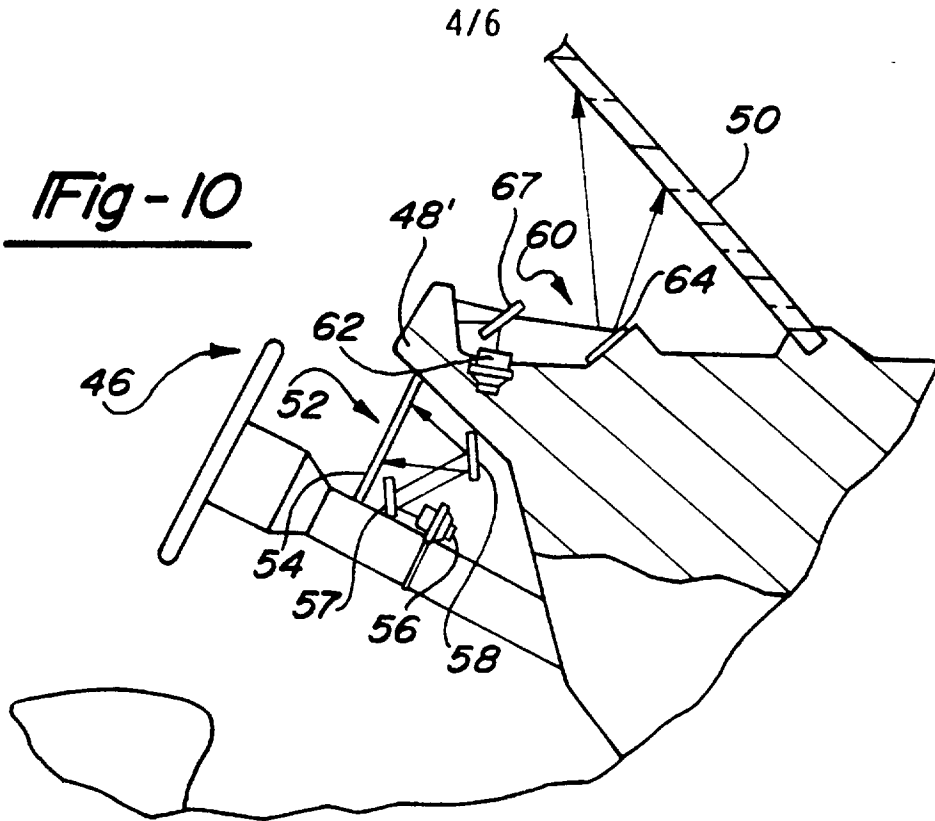

Fig - 11

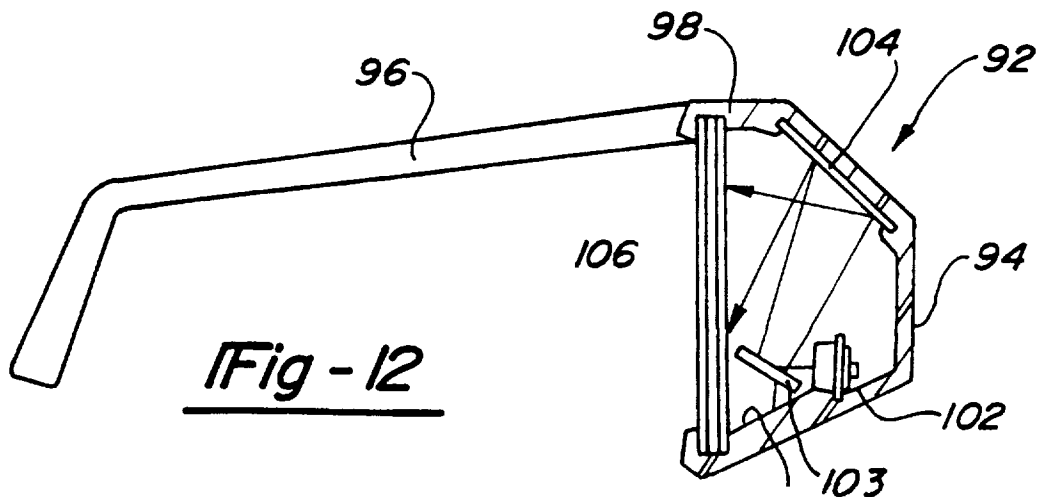

Fig - 12

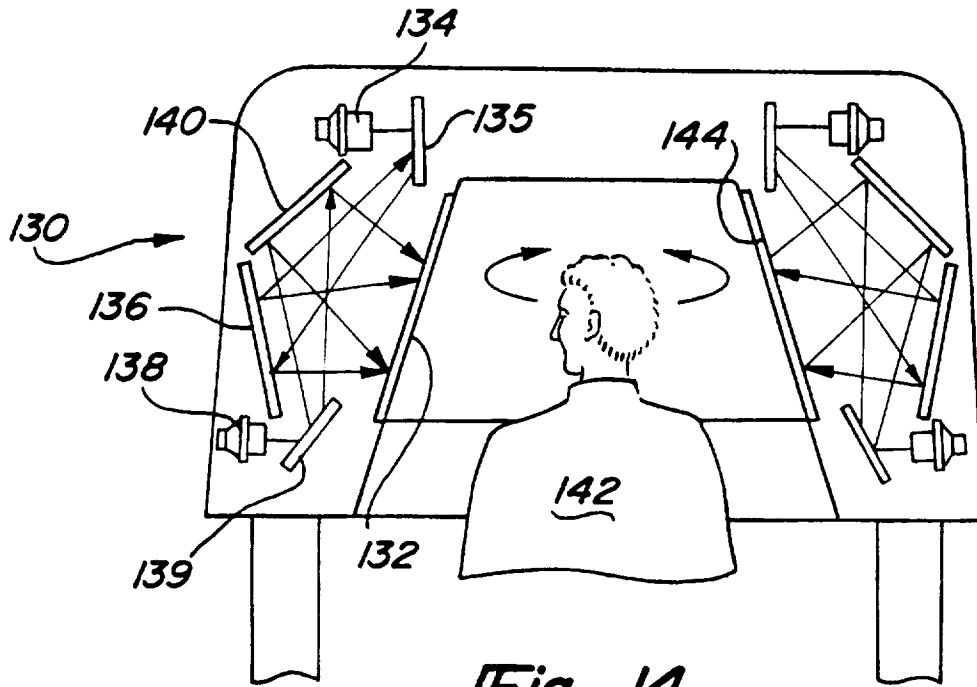

Fig - 14

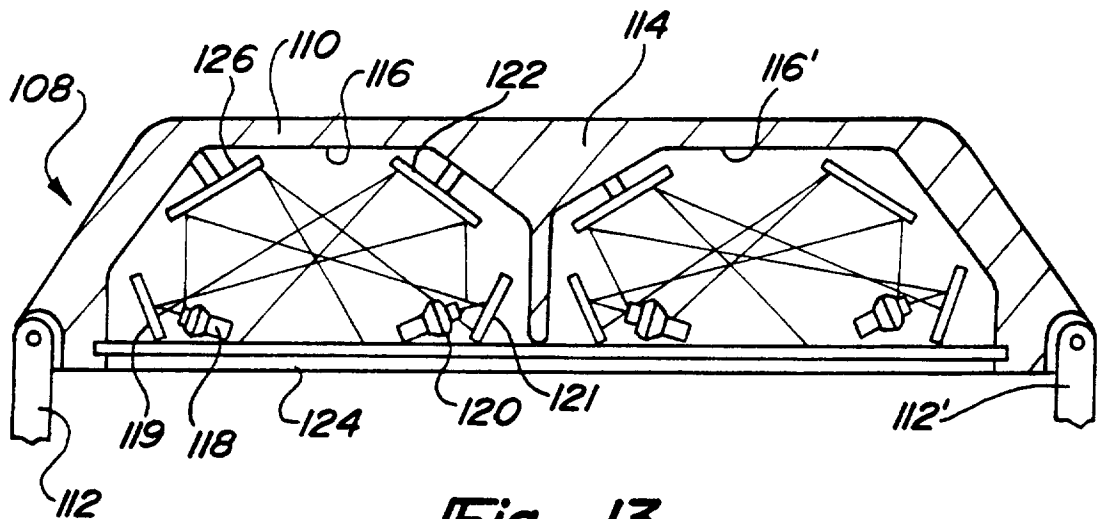

Fig - 13

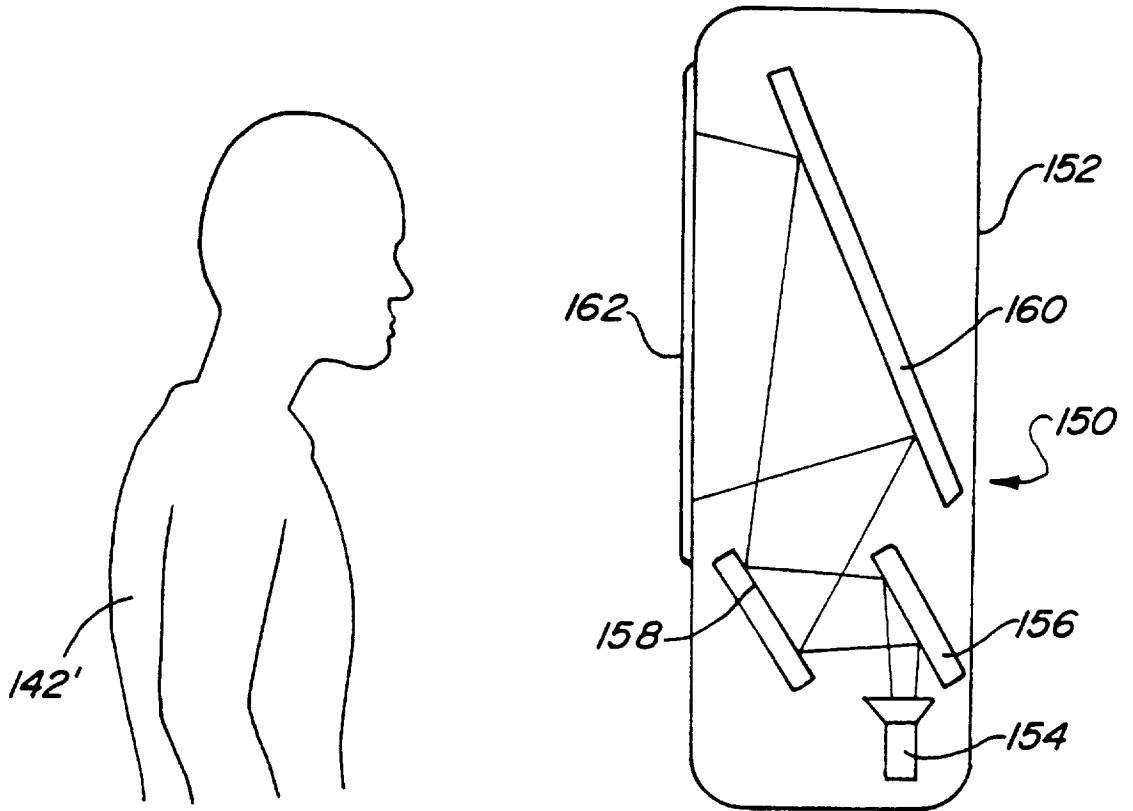

Fig - 15