

**(12) PATENT**  
**(19) AUSTRALIAN PATENT OFFICE**

**(11) Application No. AU 199715773 B2**  
**(10) Patent No. 709213**

(54) Title  
**An accumulated pot for craps qualified by a predetermined blackjack**

(51)<sup>6</sup> International Patent Classification(s)  
**A63F 001/00**

(21) Application No: **199715773**

(22) Application Date: **1997.01.10**

(87) WIPO No: **WO97/26055**

(30) Priority Data

(31) Number	(32) Date	(33) Country
<b>08/587016</b>	<b>1996.01.16</b>	<b>US</b>
<b>08/724597</b>	<b>1996.09.30</b>	<b>US</b>

(43) Publication Date : **1997.08.11**

(43) Publication Journal Date : **1997.10.02**

(44) Accepted Journal Date : **1999.08.26**

(71) Applicant(s)  
**J. Breck Brown**

(72) Inventor(s)  
**J. Breck Brown**

(74) Agent/Attorney  
**LORD and COMPANY,4 Douro Place,WEST PERTH WA 6005**

(56) Related Art  
**US 5364104**

**US 5393067**



<p>(51) International Patent Classification: <b>A63F 1/00</b></p>	<p><b>A1</b></p>	<p>(11) International Publication Number: <b>WO 97/26055</b> (43) International Publication Date: 24 July 1997 (24.07.97)</p>
<p>(21) International Application Number: PCT/US97/00498 (22) International Filing Date: 10 January 1997 (10.01.97) (30) Priority Data: 08/587,016 16 January 1996 (16.01.96) US <del>Not furnished</del> 30 September 1996 (30.09.96) US 08/724597 (71)(72) Applicant and Inventor: BROWN, J., Breck [US/US]; P.O. Box 19509, Las Vegas, NV 89132-0509 (US). (74) Agents: MILTON, Harold, W., Jr. et al.; Howard &amp; Howard Attorneys, P.C., Suite 101, 1400 North Woodward Avenue, Bloomfield Hills, MI 48304 (US).</p>	<p>(81) Designated States: AL, AM, AT, AU, AZ, BA, BB, BG, BR, BY, CA, CH, CN, CU, CZ, DE, DK, EE, ES, FI, GB, GE, HU, IL, IS, JP, KE, KG, KP, KR, KZ, LC, LK, LR, LS, LT, LU, LV, MD, MG, MK, MN, MW, MX, NO, NZ, PL, PT, RO, RU, SD, SE, SG, SI, SK, TJ, TM, TR, TT, UA, UG, UZ, VN, ARIPO patent (KE, LS, MW, SD, SZ, UG), Eurasian patent (AM, AZ, BY, KG, KZ, MD, RU, TJ, TM), European patent (AT, BE, CH, DE, DK, ES, FI, FR, GB, GR, IE, IT, LU, MC, NL, PT, SE), OAPI patent (BF, BJ, CF, CG, CI, CM, GA, GN, ML, MR, NE, SN, TD, TG).</p> <p><b>Published</b> <i>With international search report.</i></p>	

(54) Title: AN ACCUMULATED POT FOR CRAPS QUALIFIED BY A PREDETERMINED BLACKJACK

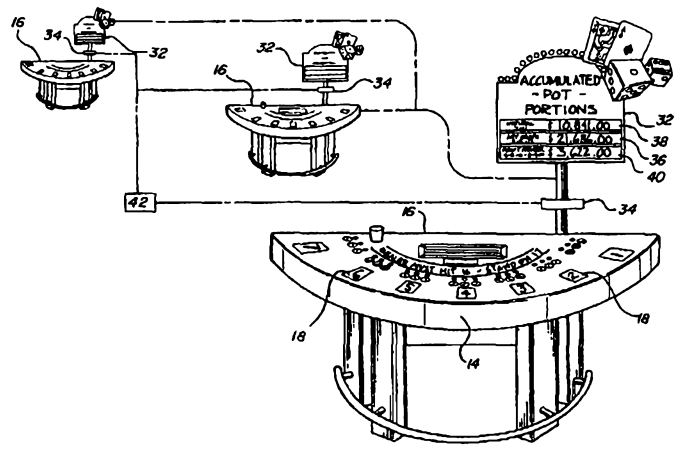

(57) Abstract

A game is disclosed for combining the play of blackjack and the play of craps based upon two dice each having six faces numbered one to six. The board (12) presents a semicircular playing arena (14) with a dealer playing area adjacent the straight diameter (16) of the semicircular playing arena and a plurality of player areas (18). Each of the player areas includes a plurality of craps wager indicator circles (20, 22, 24). After the wagers are settled based upon the play of the cards in accordance with the rules of blackjack, each player who has a blackjack is offered the roll of the dice and a craps wager. The remaining players may also place bets on one of their respective craps wager circles (20, 22, 24). Each craps wager is then settled based on the outcome of a roll of the dice by the player having the blackjack. The subject invention is characterized by interleaving an accumulating pot which is supported by each player placing a pot wager on one of the three wager indicator circles prior to the cards being dealt. A register (34) keeps track of these initial pot wagers. A player qualifies to roll the dice for a portion of the pot by having a predetermined blackjack, such as the Ace and Jack of one suit or different suits.

**AN ACCUMULATED POT FOR CRAPS QUALIFIED BY A  
PREDETERMINED BLACKJACK**

5

**TECHNICAL FIELD**

The subject invention relates to a combination card and dice game.

10

**BACKGROUND ART**

Various games are known in the prior art which combine standard playing cards and two dice. The U.S. Patent 4,746,126 to Angileri discloses a game utilizing the attributes of CRAPS with the play of cards wherein the play of the cards is dependent upon the throw of the dice. The U.S. Patent 4,515,369 discloses a game combining the elements of Craps and blackjack wherein the rules of blackjack apply to movement of game pieces as determined by the roll of the dice.

15  
20  
25

30  
35

Against this prior art background, the invention of combining the play of the card game of twenty-one, or blackjack, and the dice game of Craps was made and is disclosed and claimed in U.S. Patents 5,782,472 and 5,695,192. In accordance with that invention, at least two cards are presented to each player under the rules of blackjack and a Craps wager is offered to all of the players when at

40  
45

25

least one player has two cards equaling twenty-one. The Craps wagers are settled based upon wagers made by the individual players and the roll of the dice generally in accordance with the odds and the rules of Craps.

#### SUMMARY OF THE INVENTION

5           A method of combining the play of twenty-one and Craps comprising the steps of offering an accumulative pot wager based upon the roll of two dice prior to presenting the cards to the players, presenting at least two cards to each player, accumulating the pot wagers without payout until a qualified player has two cards of a predetermined combination to make a predetermined blackjack equaling twenty-one, rolling the dice by  
10 the qualified player, and paying out a portion of the accumulated pot to the qualified player in response to the pot wager by the qualified player covering or matching the outcome of the roll of the dice.

A device for combining the play of twenty-one based upon at least one card deck having fifty-two cards divided into four suites of duces through aces and the play of  
15 Craps based upon two dice each having six faces numbered one to six. The device includes a dealer presentation area for presenting the dealer's cards, a player presentation area for each player to present the player cards, and a plurality of Craps wager indicators for each player presentation area. The device is characterized by register means for indicating an accumulated pot wager for each player placed upon the Craps wager  
20 indicators and posting means for posting the payout of the accumulated pot from hand to hand.

## BRIEF DESCRIPTION OF THE DRAWINGS

Other advantages of the present invention will become readily appreciated as the same becomes better understood by reference to the following detailed description when considered in connection with the accompanying drawings wherein Figure 1 discloses a  
5 game board illustrating the subject invention and Figure 2 shows a plurality of playing tables networked together.

## DETAILED DESCRIPTION OF PREFERRED EMBODIMENT

An amusement device for combining the play of twenty-one and Craps is generally shown in Figure 1. The device takes the form of a mat, table cloth or cover,  
10 place mat, or the like, and may even be implemented in a computer program producing images for a monitor, or a machine making the same presentations. In any case the device comprises a presenter for positioning at least two cards for each player and a Craps wager indicator for each player to indicate the Craps wager based upon the roll of two dice by each player having only two cards equaling twenty-one.

15 As illustrated, the device is a game board or cover for combining the play of twenty-one based upon at least one card deck having fifty-two cards divided into four suites of duces through aces and the play of Craps based upon two dice each having six faces numbered one to six. The board or cloth comprises an upper playing surface 12  
20 which presents a semi-circular or arcuate playing arena, defined by the semi-circle 14 and the straight diameter 16. A dealer playing area is disposed in the middle adjacent the straight diameter 16 of the semi-circular playing arena. More specifically, the dealer playing area is in the area indicated by the indicia portraying the chip holder and chips.

This is a dealer presentation area for presenting, i.e., depositing, the dealer's cards.

The board also defines a plurality of player areas spaced about the circumference of the circular periphery 14 of the semi-circular playing arena and opposed to the dealer playing area. Each of the player areas comprises a rectangular card box 18 defining a  
5 player presentation area for each player to present or deposit the player cards. This box may be defined by a space or a multitude of indicia instead of or in addition to the cards and dice shown, as for example, an Ace and Jack of spades in an array with two dice. A plurality of Craps wager indicator areas 20, 22 and 24 are disposed adjacent each player area 18 to divide the numbers 2 through 12 into a plurality of groups for wagering at  
10 different odds for each group. More specifically, a plurality of three Craps wager indicator areas 20, 22 and 24 are presented for each player with each indicator area presenting different odds for different total dice numbers. A first of the indicators, i.e., indicator area 20, presents the numerals 7 and 11 for first odds of nine for two, a second indicator area 22 presents the numerals 2, 3 and 12 for second odds of nine for one, and  
15 a third indicator area 24 presents the remaining numbers for third odds of three for two.

The game board 10 presents an odds area 26 centrally located and indicating the first, second and third odds for the respective wager indicator areas 20, 22 and 24. That is, the first table pay-off odds are nine chips for two chips bet on a natural 7 or 11; the second table pay-off odds are nine chips for one chip bet on Craps 2, 3 or 12; and the third  
20 table pay-off odds are three chips for two chips bet on the point numbers 4,5,6,8, 9 or 10. The first true odds are three and one half to one for a natural 7 or 11, the second true odds are eight to one for Craps 2, 3 or 12, and the third true odds are one to two for

point numbers *4, 5, 6, 8, 9* or *10*. The board may include other informative indicia like the dealer must take a card when at sixteen and stand at seventeen in blackjack.

The play of twenty-one, i.e., blackjack, and Craps is combined in the basic steps

5 of presenting at least two cards to each player followed by then offering a Craps wager based upon the roll of two dice to a player having two cards equaling twenty-one, i.e., to each player having a blackjack. Each player having blackjack then places a Craps wager and rolls the dice, alternatively, to qualify to roll the dice the player, in addition to having a blackjack, must also beat the dealer. The wagers are then settled based upon the

10 outcome of the roll of the dice. The offering of the Craps wager includes the offer of a plurality of alternative dice number combinations in groups having different betting odds. More specifically, the offering of the wager combinations are divided into the dice number combinations of the natural *7* or *11* at first odds, the dice number combinations of any Craps *2, 3* or *12* at second odds, and the remaining dice number combinations of

15 the point numbers *4, 5, 6, 8, 9*, or *10* at different third odds. For example, the numerals *7* and *11* may be at first odds of nine for two, the numerals *2, 3* and *12* may be at second odds of nine for one, and the remaining numbers of *4, 5, 6, 8, 9*, and *10* may be at third odds of three for two. Of course, these odds may vary as in accordance with individual house rules. These three groups of numbers are respectively presented in the first, second

20 and third indicator areas *20, 22* and *24* respectively for each player.

The play of twenty-one is based upon at least one card deck having fifty-two cards divided into four suites of duces through aces and the play of Craps based upon two dice

each having six faces numbered one to six. It involves the placing of a blackjack wager on behalf of each player to beat a dealer player by placing chips in front of the card boxes 18. The dealer, or machine, presents two cards to each player including the dealer player by placing the cards on the card boxes 18 in sequence about the semi-circle 14. As is 5 normal in the game of blackjack, additional cards are sequentially presented to each player in response to a request for same from that player. Thereafter, the blackjack wagers are paid or settled in the absence of requests for additional cards.

The opportunity or option to roll two dice is then presented to each player having a blackjack consisting of only two cards equaling twenty-one. However, before the roll 10 of the dice, each player establishes a Craps wager, if the player wishes to participate, based upon the roll of the two dice by placing chips on one of the three circles 20, 22 and 24 to indicate the numbers and odds of the roll. The blackjack winner then rolls the dice once and each Craps wager by each player is settled based the outcome of the roll of the dice by the blackjack winner.

15 The subject invention provides an accumulated pot variation which may be combined with or substituted for the wager entitlement which occurs upon a player having two cards equaling twenty-one. In either case, the two are completely independent as the wagers on the accumulated pot are accumulated separately and paid out on independent criteria. However, in the preferred embodiment, the accumulated pot is played along with 20 or in conjunction with the Craps wager entitlement.

More specifically, the accumulated pot variation is played by offering an accumulative pot wager based upon the roll of two dice prior to presenting the cards to



the players. In other words, the entire game is initiated by each player placing a pot wager on one or more of the Craps wager indicator areas 20, 22 and 24. The system will include a register for indicating the pot wager placed by each player upon the Craps wager indicator areas 20, 22 and 24, i.e., the register will indicate the one of the three  
5 Craps wager indicator areas 20, 22 and 24 upon or into which each player has placed a pot wager. Each wager indicator area 20, 22 and 24 could have a slot 28 for receiving and electronically counting the chip wagered on the pot with an indicator light 30 to indicate the area wagered.

The game proceeds as described above with the Craps wager indicator areas 20,  
10 22 and 24 used by the players to place wagers in the event one of the players gets twenty-one. Successive hands are dealt and played while accumulating the pot wagers without payout until a player becomes a qualified player by having two cards of a predetermined combination to make a predetermined blackjack equaling twenty-one. In other words, when a player receives a predetermined blackjack, e.g., a predetermined combination of  
15 an Ace and a Jack of the same suit or different suits, or specifically the Ace of hearts and the Jack of spades, that player becomes a qualified player eligible to win a portion of the accumulated pot.

The qualified player rolls the dice to match his initial pot wager placed at the beginning of the game and which the register light 30 has indicated throughout the play.  
20 If the player placed wagers on more than one indicator area, the player rolls the dice once for each different indicator area upon which the player placed a wager. Accordingly, all or at least a portion of the accumulated pot is paid out to the qualified player in response to the registered pot wager by the qualified player covering the outcome of the roll of the

dice. That is, the accumulated pot is paid to the player if the roll of the dice for a certain indicator area matches any of the numbers in that indicator area. The accumulated pot is divided into three different payout portions each corresponding to one of the Craps wager indicator areas 20, 22 and 24. Hence, the pot wager is made on the dice number combinations of 2, 3 and 12 at the greatest payout portion and dice number combinations of 7 and 11 at a lesser payout portion and the remaining dice number combinations at the smallest payout portion. There is also included a posting means comprising a sign for posting the respective greatest, lesser and smallest payout portions. As the pot grows from hand to hand a counter calculates the respective payouts and the amounts continually change on the electronic sign.

To further enhance the game by increasing the accumulated pot faster and to higher amounts, a plurality of playing sites, i.e., individual tables each with its own dealer, may be combined electronically to establish one common combined pot. This common combined pot is divided into three portions, each of which is paid out to the first player having the winning combination of a predetermined blackjack and rolling the dice to match his registered pot wager. Otherwise, the pot wagers are accumulated without payout from hand to hand until a qualified Craps player has the predetermined winning combination. The pot wagers placed on the respective wager indicator areas 20, 22 and 24 may be accumulated separately, i.e., individually, to establish independent posted portions on the electronic signs 32 which may vary from time to time in proportion to the number of wagers in each wager indicator area 20, 22 and 24 and/or the lack of winning players in one or two pot portions. After a win, that portion of the pot may be seeded to start a new series of hands.

Accordingly, at one seating a player may play blackjack and qualify to further bet on a Craps roll of the dice each time the player receives a blackjack, and, in addition, to place pot wagers to qualify for rolling the dice for the pot in the event of receiving a predetermined blackjack, such as the Ace and Jack of one designated combination.

5 Alternatively, the invention may interleave the pot wager with similar card games which are played from hand to hand under conventional rules until a player qualifies to roll the dice for at least a portion of the pot by beating the dealer in the card game with a predetermined combination of cards which is generally more difficult to acquire than lesser winning combinations and then follows up with a roll of the dice producing numbers in

10 the group of numbers the player wagered upon in the pot wager at the beginning of the hand.

In the preferred sequence of play, a first accumulative pot wager is offered to each player at a first group 20 of numbers at first odds based upon the roll of two dice. At the same time, second and third accumulative pot wagers are offered to each player at

15 respective second and third groups 22 and 24 of numbers at second and third odds based upon the roll of two dice. Each player places a blackjack wager on behalf to beat a dealer player at blackjack in accordance with the normal rules of blackjack. The dealer or machine then presents two cards to each player including the dealer player to begin a hand. At this point, if no player has a blackjack, the first accumulative pot wagers are

20 accumulated in a first accumulative pot without payout from card game to card game until a qualified pot player has cards of a predetermined combination equaling twenty-one, i.e., a blackjack, and makes a winning roll of the dice. Likewise, the second and third accumulative pot wagers are accumulated in a second accumulative pot and in a third

accumulative pot respectively without payout from card game to card game until being won by a winning qualified pot player having cards of a predetermined combination equaling twenty-one, i.e., a blackjack, and makes a winning roll of the dice. As the respective accumulated pots increase from hand to hand because no player becomes a winning qualified pot player, or, if so, does not roll a number on the dice which matches a number in the indicator area upon which that player placed an accumulative pot wager, a posting means 32 posts the payout of the first accumulated pot to the winning qualified player in response to the numbers resulting from the roll of the dice by the winning qualified player matching one of the numbers in the first indicator area 20 upon which the winning qualified player placed a first accumulative pot wager and for posting the payout of the second accumulated pot to the winning qualified player in response to the numbers resulting from the roll of the dice by the winning qualified matching one of the numbers in said second indicator area 22 upon which the winning qualified player placed a second accumulative pot wager and for posting the payout of the third accumulated pot to the winning qualified player in response to the numbers resulting from the roll of the dice by the winning qualified matching one of the numbers in said third indicator area 24 upon which the winning qualified player placed a third accumulative pot wager. The posting means 32 includes a computer and counter to keep track of the wagers on the respective indicator areas 20, 22 and 24.

20           However, if a player has a predetermined combination of cards, such as the Ace of hearts and the Jack of spades, the player becomes a qualified pot player and is entitled to the roll of two dice for the accumulated pot upon which the player placed a wager, i.e., one or more of the wager indicator areas 20, 22 and/or 24, at the onset of the game.

Accordingly, either a dealer or a machine presents a roll of the two dice to the qualified pot player having the predetermined combination of cards for a wager placed by the qualified pot player on the first group 20, i.e., first indicator area 20. Sequentially, that same qualified player having the predetermined combination of cards is presented a roll of the two dice for a wager placed by that qualified pot player on the second group, i.e., indicator area 22. And thereafter, that same qualified player having the predetermined combination of cards is presented a roll of the two dice for a wager placed by that qualified pot player on the third group, i.e., indicator area 24. Instead of actual dice, the roll of the dice could be accomplished by the dealing of cards having dice numbers or by a computer or a machine. Only the player having the predetermined combination of cards is allowed to roll the dice for the accumulated pot and then only for the accumulated pot upon which that player placed a wager at the onset of the hand. If the qualified player placed a wager on more than one of the indicator areas 20, 22 and 24, that qualified player is presented the a roll of the dice for each indicator area, i.e., each accumulative pot, upon which that player initially placed a an accumulative pot wager. The initial accumulative pot wagers by all of the other players are cleared and placed into the accumulative pot as posted by the posting means or sign 32. Accordingly, just before the pot player rolls the dice for the accumulated pot or pots, the wager indicator areas 20, 22 and 24 are cleared with the wagers going to the respective accumulated pots with a corresponding increase in the value posted by the posting means 32 for the respective pots.

If upon the rolling the two dice by the qualified Craps player, the numbers on the dice match one of the numbers in the indicator area 20, 22 or 24 for which the dice were rolled, then the accumulated pot as indicated on the posting means 32 is paid out to the

player. In other words, if the qualified player is rolling the dice for a wager placed upon the first indicator area 20, i.e., the first accumulative pot, at least a portion of the first accumulated pot is paid out to the winning qualified player in response to the numbers resulting from the roll of the dice matching one of the numbers in the first group of numbers set forth in the first indicator area 20. In a similar fashion, if the qualified player is rolling the dice for a wager placed upon the second indicator area 22, i.e., the second accumulative pot, at least a portion of the second accumulated pot is paid out to that winning qualified player in response to the numbers resulting from the roll of the dice matching one of the numbers in the second group of numbers set forth in the second indicator area 22. The same occurs if the qualified player is rolling the dice for a wager placed upon the third indicator area 24, i.e., the third accumulative pot, at least a portion of the third accumulated pot is paid out to that winning qualified player in response to the numbers resulting from the roll of the dice matching one of the numbers in the third group of numbers set forth in the third indicator area 22.

In the absence of a player having the predetermined combination of cards to qualify to roll the dice for one or more accumulative pots, or after that qualified player has rolled the dice for the accumulative pot or pots, each player having two cards equaling twenty-one is identified as a natural blackjack player. This includes the player having the predetermined combination because that is also a natural blackjack. For each player having a natural blackjack, a craps wager is presented, i.e., offered, to each player on one of the first, second and third groups of numbers. Said another way, each player may place a wager on one of the indicator areas 20, 22 or 24 in front of the player, but only one of the areas for one set of odds. After all bets are placed on the respective indicator areas

20, 22 or 24, a roll of the two dice is presented to the natural blackjack player who then rolls the dice. Each player is then paid the designated odds in response to the numbers resulting from the roll of the dice by the natural blackjack player matching one of the numbers in the group of numbers upon which that player placed a craps wager. The same  
5 sequence is conducted for each natural blackjack.

After all of the opportunities for rolling the dice based upon blackjacks or two card twenty-one are resolved, the normal game of blackjack proceeds by sequentially presenting additional cards to each player in response to a request for same from that player. As is customary in blackjack, the blackjack wagers are paid in the absence of  
10 requests for additional cards and the hand comes to an end, ready to start over with a new deal. As will be appreciated, the various steps, order of play or sequence of play may be varied without departing from the inventive combination.

As alluded to above, the method is further defined as offering 2, 3 or 12 as the first group of numbers at the first payout odds and offering 7 and 11 as the second  
15 group of numbers at the second payout odds and offering the remaining dice number combinations as a third group at third payout odds.

A further refinement includes the steps of combining the play of at a plurality of independent playing sites with a dealer at each site by combining the first accumulated pot from the plurality of independent playing sites and paying out at least a portion of the  
20 combined first accumulated pot to the winning qualified player as well as similarly independently combining the second and third accumulated pots from the plurality of independent playing sites and paying out at least a portion of the respective combined

second and third accumulated pots to the winning qualified player.

Although the gaming device for implementing play may comprise a machine, it frequently employs a gaming table presenting an upper playing surface. A plurality of player areas are spaced about the periphery of the arcuate playing arena and opposed to the dealer playing area. Each of the player areas comprises a card box 18 and a plurality of group indicator areas 20, 22 and 24 dividing the numbers 2 through 12 into a plurality of groups for presenting a first accumulative pot wager to each player at a first indicator area 20 presenting a first group of the numbers at first odds based upon the roll of two dice and for presenting a second accumulative pot wager to each player at a second indicator area 22 presenting a second group of the numbers at second odds based upon the roll of two dice and for presenting a third accumulative pot wager to each player at a third indicator area 24 presenting a third group of the numbers at third odds based upon the roll of two dice.

A first of the registers 30 is included for each player to indicate a first accumulative pot wager placed by each player upon the first indicator area 20. A second of the registers 30 is included for indicating a second accumulative pot wager placed by each player upon the second indicator area 22. Similarly, a third of the registers 30 is included for indicating a third accumulative pot wager placed by each player upon the third indicator area 24.

Each table includes a computerized totalizing device 34 for providing a first accumulation means for adding the first accumulative pot wagers 20 from hand to hand into a first accumulated pot until being won by a winning qualified pot player having



cards of a predetermined combination equaling twenty-one. The running summation of that first accumulated pot is posted by a first sign 36 of the posting means 32 for each table. The device 34 also provides a second accumulation means for adding the second accumulative pot wagers 22 from hand to hand into a first accumulated pot until being  
5 won by a winning qualified pot player having cards of a predetermined combination equaling twenty-one. The running summation of that second accumulated pot is posted by a sign 38 of the posting means 32 for each table. The device 34 also provides a third accumulation means for adding the third accumulative pot wagers 24 from hand to hand into a first accumulated pot until being won by a winning qualified pot player having  
10 cards of a predetermined combination equaling twenty-one. The running summation of that third accumulated pot is posted by a sign 40 of the posting means 32 for each table.

In addition, a networking means 42 may be included for combining the play of at a plurality of independent playing sites or tables with a dealer at each site by combining the first accumulated pot from the plurality of independent playing sites and paying out  
15 at least a portion of the combined first accumulated pot to the winning qualified player. In the event the first accumulated pot is combined among a plurality of sites or tables, the first sign 36 at each table will show that combined pot which could be won by a winning qualified player at any one of the networked tables. Of course, the networking means 42 would also independently combine the respective second and third accumulated pots from  
20 the plurality of independent playing sites.

As alluded to above, the dice rolling means is included for presenting a roll of the two dice to the winning qualified pot player for a wager placed by the winning qualified pot player on the first indicator area 20 and for presenting a roll of the two dice to the

What is claimed:

1. The method of combining the play of a card game and craps comprising the steps of:

providing a plurality of playing cards;

5 presenting at least two cards to each player;

establishing a wager based upon the roll of two dice for a player having a particular set of cards;

providing a pair of dice to roll;

rolling the dice; and

10 settling the wager based upon the outcome of the roll of the dice.

2. A method as set forth in claim 1 wherein the offering of the wager includes the offer of a plurality of alternative dice number combinations in groups having different betting odds.

3. A method as set forth in claim 2 further defined as offering the dice number combinations of 7 or 11 at first odds, and the remaining dice number combinations at different odds.

4. A method as set forth in claim 1 wherein said card game is twenty-one and the particular set of cards is blackjack.

5. A method as set forth in claim 1 wherein the card game utilizes a deck of cards including 52 cards divided into suites of deuces through aces.

6. A method as set forth in claim 1 including;  
establishing an accumulative pot wager for at least one player and based upon a combination of dice numbers resulting from the roll of the two dice prior to presenting the cards to each player;



winning qualified pot player for a wager placed by the winning qualified pot player on the second indicator area 22 and for presenting a roll of the two dice to the winning qualified pot player for a wager placed by the winning qualified pot player on the third indicator area 24. This dice rolling means could be a cup, a closed and clear walled container for rolling the dice within the container, or cards having a dice number on each of at least 5 twelve cards, or a computerized or mechanized device for randomly selecting the dice number.

The invention has been described in an illustrative manner, and it is to be understood that the terminology which has been used is intended to be in the nature of 10 words of description rather than of limitation. Obviously, many modifications and variations of the present invention are possible in light of the above teachings. It is, therefore, to be understood that within the scope of the appended claims, wherein reference numerals are merely for convenience and are not to be in any way limiting, the invention may be practiced otherwise than as specifically described.

15

accumulating all of the accumulative pot wagers into an accumulated pot without payout from hand to hand until a player becomes a qualified player by having two cards of a predetermined combination to make a predetermined blackjack equaling twenty-one;

5 rolling the dice by the qualified player; and  
paying out a portion of the accumulated pot to the qualified player in response to the pot wager by the qualified player covering the outcome of the roll of the dice.

7. A method as set forth in claim 6 wherein the offering of the pot wager  
10 includes the offer of a plurality of alternative dice number combinations in groups having different amounts of payout portions.

8. A method as set forth in claim 7 further defined as offering the dice  
number combinations of 2, 3 or 12 at the greatest payout portion and dice number combinations of 7 and 11 at a lesser payout portion and the remaining dice number  
15 combinations at the smallest payout portion.

9. A method as set forth in claim 6 wherein the predetermined combination of cards comprises a predetermined combination of an Ace and a face card.

10. A method of combining the play of cards game based upon at least one  
20 card deck having fifty-two cards divided into four suites of duces through aces and the play of craps based upon two dice each having six faces numbered one to six, said method comprising the steps of:

at least one card deck having fifty-two cards divided into four suites of duces through aces;



placing a card wager on behalf of each player;

presenting at least two cards to each player including the dealer player;

providing two dice;

5 presenting the two dice to each player with a blackjack consisting of only two cards equaling twenty-one;

establishing a craps wager for each participating player based upon the roll of the two dice;

settling each craps wager based upon the outcome of the roll of the dice;

10 sequentially presenting additional cards to each player; and

paying the wagers in the absence of requests for additional cards.

11. A method as set forth in claim 11 wherein the offering of the craps wager includes the offer of a plurality of alternative dice number combination in groups having different betting odds.

15 12. A method as set forth in claim 12 further defined as offering the dice number combinations of 7 or 11 at first odds, and the remaining dice number combination at different odds.

20 13. A method as set forth in claim 13 further defined as offering the dice number combinations of the natural 7 or 11 at first odds, the dice number combinations of any craps 2, 3 or 12 at second odds, and the remaining dice number combinations of the point numbers 4, 5, 6, 8, 9 or 10 at different odds.

14. A method of combining the play of a game of chance and craps based upon two dice, said method comprising the steps of:



presenting a first group of dice numbers 7 and 11 at first odds based upon the roll of two dice;

presenting a second group of dice numbers 2, 3 and 12 at second odds based upon the roll of two dice;

5 presenting a third group of dice numbers 4, 5, 6, 8, 9 and 10 at third odds based upon the roll of two dice;

establishing an accumulative pot wager for each player on one or more of the groups;

playing a game of chance through a round to determine a player winner;

10

accumulating all of the accumulated pot wagers into at least one accumulated pot without payout from round to round of the game of chance until a player winner becomes a qualified player by having a predetermined win to thereby qualify to roll the dice for at least a portion of the accumulated pot;

15

providing a pair of dice to roll;

rolling the dice by the qualified player; and

payout out a portion of the accumulated pot to the qualified player in response to the pot wager by the qualified player being on the group of numbers which match the numbers from the roll of dice.

20

15. A method of combining the play of twenty-one and the play of craps, said method comprising the steps of:

providing two dice each having six faces numbered one to six;

providing at least one card deck having fifty-two cards divided into four suites of duces through aces;

placing a blackjack wager on behalf of each player to beat a dealer player;

5 establishing an accumulative pot wager for each player based upon a combination of dice numbers resulting from the roll of two dice prior to presenting the cards to the players;

presenting two cards to each player including the dealer player to begin a hand;

sequentially presenting additional cards to each player in response to a request for same from that player;

10 paying the blackjack wagers in the absence of requests for additional cards to end the hand;

15 establishing a craps wager to each participating player based upon a combination of dice numbers resulting from the roll of the two dice in response to a player becoming a qualified craps player by beating the dealer with a blackjack of two cards equaling twenty-one;

rolling the two dice by the qualified craps player;

settling each craps wager based on the outcome of the roll of the dice;

20 paying out at least a portion of the accumulated pot to the qualified craps player in response to the winning combination of the qualified craps player having a blackjack consisting of a predetermined combination of cards equaling twenty-one and a roll of the dice by the qualified craps player matching the accumulative pot wager; and

accumulating the pot wagers without payout from hand to hand until a qualified craps player has the winning combination.



16. A method as set forth in claim 15 wherein the predetermined combination of cards comprises a predetermined combination of an Ace and a face card.

5 17. A method as set forth in Claim 15 wherein the offering of the pot wager includes the offer of a plurality of alternative dice number combinations of 2, 3 or 12 at the greatest payout portion and dice number combinations of 7 and 11 at a lesser payout portion and the remaining dice number combinations at the smallest payout portion.

10 18. A method as set forth in claim 17 including posting the respective amounts of the payout portions.

19. A method of combining the play of cards and craps comprising the steps of:

presenting the dice numbers 1 to 12 divided into three groups of dice numbers with each group at different odds based upon the roll of two dice;

15 establishing an accumulative pot wager for each player on one or more of the groups;

providing a plurality of playing cards;

thereafter presenting at least two cards to each player and proceeding with the play of the card game;

20 accumulating all of the accumulative pot wagers into an accumulated pot without payout from card game to card game until a player becomes a qualified player by having cards of a predetermined combination to thereby qualify to roll the dice for at least a portion of the pot;

providing a pair of dice to roll;





rolling the dice by the qualified player; and

paying out a portion of the accumulated pot to the qualified player in response to the pot wager by the qualified player being on the group of numbers which match the numbers resulting from the roll of the dice.

5           20.    A method of combining the play of blackjack and the play of craps, said method comprising the steps of:

          providing two dice each having six faces numbered one to six;

          providing at least one card deck having fifty-two cards divided into four suites of duces through aces;

10           establishing a first accumulative pot wager to each player at a first group of numbers at first odds based upon the roll of the two dice;

          establishing a second accumulative pot wager to each player at a second group of numbers at second odds based upon the roll of the two dice;

15           placing a blackjack wager on behalf of each player to beat a dealer player;

          presenting two cards to each player including the dealer player to begin a hand;

          sequentially presenting additional cards to each player in response to a request for same from that player;

20           paying the blackjack wagers in the absence of requests for additional cards to end the hand;

          presenting a roll of the two dice to a player becoming a qualified player by having a predetermined combination of cards equaling twenty-one in response to the qualified player having placed a first accumulated pot wager on the first group;

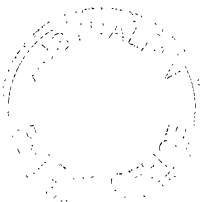

accumulating all of the first accumulative pot wagers in a first accumulative pot without payout from card game to card game;

presenting a roll of the two dice to the qualified pot player in response to a second accumulative pot wager placed by the qualified pot player on the second group;

5

accumulating all of the second accumulative pot wagers in a second accumulative pot without payout from card game to card game;

rolling the two dice by the qualified craps player;

paying out at least a portion of the first accumulated pot to the winning qualified player in response to the numbers resulting from the roll of the dice matching one of the numbers in the first group of numbers;

10

paying out at least a portion of the second accumulated pot to the winning qualified player in response to the numbers resulting from the roll of the dice matching one of the numbers in the second group of numbers;

15

identifying each player having two cards equaling twenty-one as a natural blackjack player;

presenting a craps wager to each player on one of the first and second groups of numbers;

presenting a roll of the two dice to the natural blackjack player; and

20

paying each player the designated odds in response to the numbers resulting from the roll of the dice by the natural blackjack player matching one of the numbers in the group of numbers upon which the player placed a craps wager.

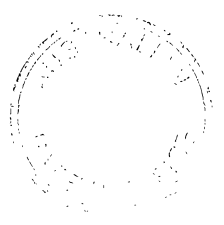

21. A method as set forth in claim 20 further defines as offering 2, 3 or 12 as the first group of numbers at the first payout odds and offering 7 and 11 as the second group of numbers at the second payout odds and offering the remaining dice number combinations as a third group at third payout odds.

5 22. A game board for combining the play of cards and the play of craps, said board comprising:

an upper playing surface;

said playing surface defined by a semi-circular playing arena;

a dealer playing area adjacent the semi-circular playing arena;

10 a plurality of player areas spaced about the circumference of the circular periphery of said semi-circular playing arena and opposed to said dealer playing area, each of said player areas comprising a box and first, second and third craps wager indicator areas dividing the numbers 2 through 12 into three groups for wagering at different odds for each group, said first indicator area including the  
15 numbers 7 and 11 for first odds, said second indicator area including the numbers 2, 3 and 12 for second odds, and said third indicator area including the remaining numbers 4, 5, 6, 8, 9 and 10 for third odds, and an odds area indicating said first, second and third odds.

20 23. An amusement device for combining a game of chance and craps comprising:

a game of chance for one or more players to establish at least one winning player;



first, second and third craps wager indicators for each player for dividing the dice numbers 2 through 12 into three groups for wagering at different odds for each group;

5 said first indicator presents 7 and 11 for first odds, said second indicator presents 2, 3 and 12 for second odds, and said third indicator presents 4, 5, 6, 8, 9 and 10 for third odds;

an odds indicator for presenting said first, second and third odds; and means for rolling a pair of dice.

10 24. A device for combining the play of twenty-one based upon at least one card deck having fifty-two cards divided into four suites of duces through aces and the play of craps based upon two dice each having six faces numbered one to six, said device comprising:

- a dealer presentation area for presenting the dealer's cards;
- a player presentation area for each player to present the player cards;
- 15 a plurality of craps wager indicators for each player presentation area;
- register means for indicating a pot wager for each player placed upon the craps wager indicators; and

posting means for posting the payout of the accumulated pot from hand to hand.

20 25. A device as set forth in claim 24 wherein said wager indicators present the dice number combinations of 2, 3 or 12 at the greatest payout portion and dice number combinations of 7 and 11 at a lesser payout portion and the remaining dice number combinations at the smallest payout portion.



26. A device as set forth in claim 25 wherein said posting means includes a means for posting the respective greatest, lesser and smallest payout portions.

27. A gaming device for combining the play of twenty-one based upon at least one card deck having fifty-two cards divided into four suites of duces through aces and the play of craps based upon two dice each having six faces numbered one to six, said device comprising:

an upper playing surface;

said playing surface presenting an arcuate playing arena;

a dealer playing area in the middle of the playing arena;

a plurality of player areas spaced about the periphery of said arcuate playing arena and opposed to said dealer playing area, each of said player areas comprising a box and a plurality of craps wager indicator areas dividing the numbers 2 through 12 into a plurality of groups for wagering at different odds for each group;

register means for indicating an accumulative pot wager placed by each player upon one of the craps wager indicator areas; and

accumulation means for adding the pot wagers from hand to hand until a qualified craps player beats the dealer player with a blackjack consisting of a predetermined combination of cards equaling twenty-one and the pot wager by the qualified craps player covers the outcome of the roll of the dice.

28. A device as set forth in claim 27 including posting means for posting the payout of the accumulated pot from hand to hand.

29. A device as set forth in claim 28 including networking means for accumulating a single pot from the plurality of independent playing sites with a dealer at each site.

30. A gaming device for combining the play of twenty-one based upon at least one card deck having fifty-two cards divided into four suites of duces through aces and the play of craps based upon two dice each having six faces numbered one to six, said device comprising:

5 an upper playing surface;

said playing surface presenting an arcuate playing arena;

a dealer playing area in the middle of the playing arena;

a plurality of player areas spaced about the periphery of said arcuate playing arena and opposed to said dealer playing area, each of said player areas comprising a box and a plurality of group indicator areas dividing the numbers 2 through 12 into a plurality of groups for presenting a first accumulative pot wager to each player at a first indicator area presenting a first group of said numbers at first odds based upon the roll of two dice and for presenting a second accumulative pot wager to each player at a second indicator area presenting a second group of said numbers at second odds based upon the roll of two dice;

15 first register means for indicating a first accumulative pot wager placed by each player upon said first indicator area;

second register means for indicating a second accumulative pot wager placed by each player upon said second indicator area;

20 first accumulation means for adding said first accumulative pot wagers from hand to hand into a first accumulated pot until being won by a winning qualified pot player having cards of a predetermined combination equaling twenty-one;

second accumulation means for adding said second accumulative pot wagers from hand to hand into a second accumulated pot until being won by a winning qualified pot player having cards of a predetermined combination equaling twenty-one;

5                   dice rolling means for presenting a roll of the two dice to the winning qualified pot player for a wager placed by the winning qualified pot player on said first indicator area and for presenting a roll of the two dice to the winning qualified pot player for a wager placed by the winning qualified pot player on said second indicator area; and

10                   posting means for posting the payout of the first accumulated pot to the winning qualified player in response to the numbers resulting from the roll of the dice by the winning qualified player matching one of the numbers in said first indicator area upon which the winning qualified player placed a first accumulative pot wager and for posting the payout of the second accumulated pot to the winning qualified  
15                   player in response to the numbers resulting from the roll of the dice by the winning qualified matching one of the numbers in said second indicator area upon which the winning qualified player placed a second accumulative pot wager.

20                   31.     A device as set forth in claim 30 wherein said first group of numbers consists of 2, 3 or 12 in said first indicator area and second group of numbers consists of 7 and 11 in said second indicator area and including a third indicator area presenting the remaining dice number combinations as a third group at third odds.



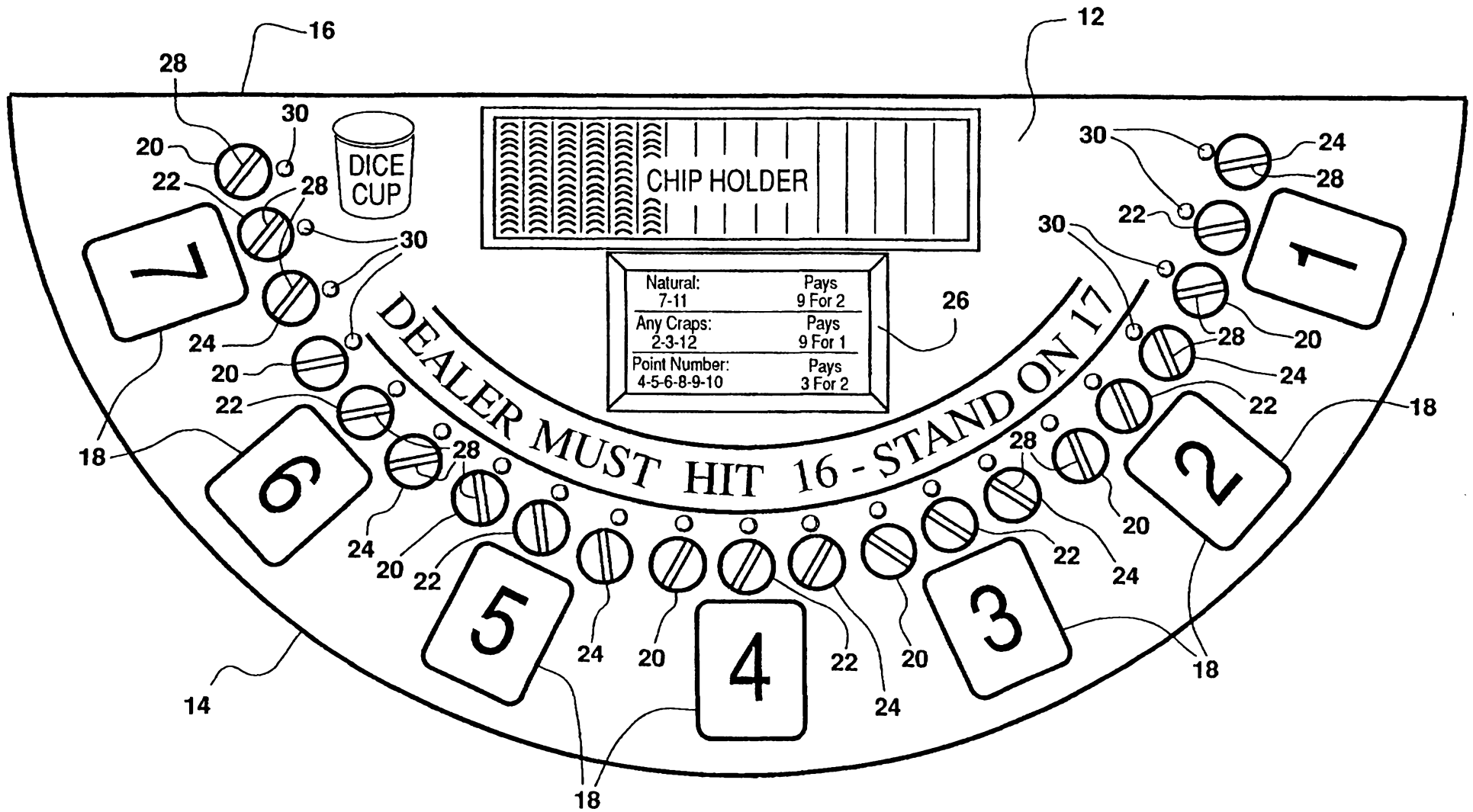

**FIG - 1**



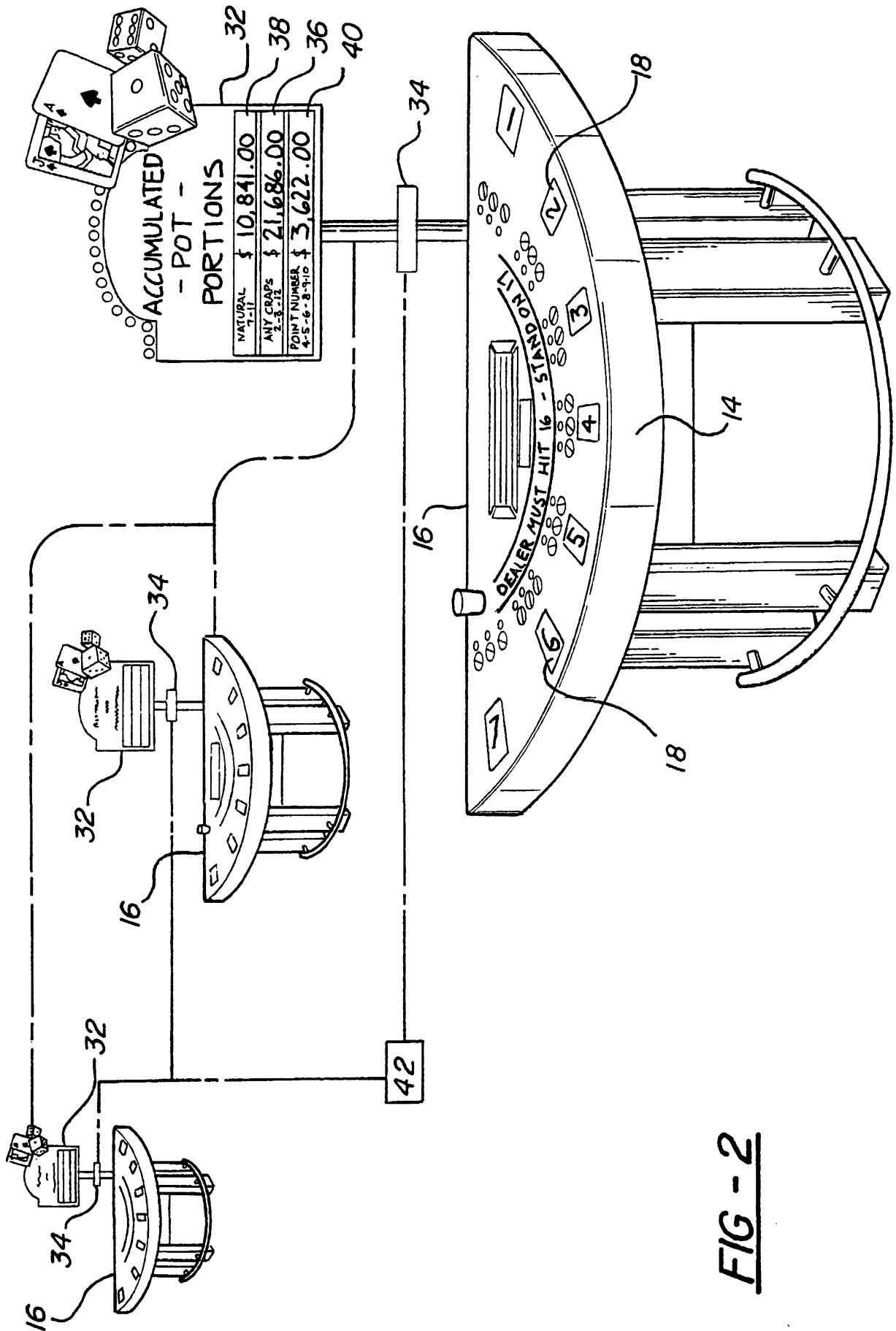

FIG - 2