

(19) (12) (KR) (A)

(51) 。 Int. Cl.⁷
 B23P 15/28
 B23B 27/14
 B23C 5/20

(11)
 (43)

10-2004-0105725
 2004 12 16

(21) 10-2004-7012938

(22) 2004 08 19

2004 08 19

(86) PCT/IB2003/000604

(87)

WO 2003/070418

(86) 2003 02 20

(87)

2003 08 28

(30) 2002/1473

2002 02 21

(ZA)

(71) ()

1559

(72)

2144

6

2193

7 가

11

2194

50

1724

10

12

-915 32

28

-918 94

121

-915 92

34

-906 55

53

(74)

:

(54)

,

(12, 14)
PCBN

PCD

(10),
가

가

(12)

2

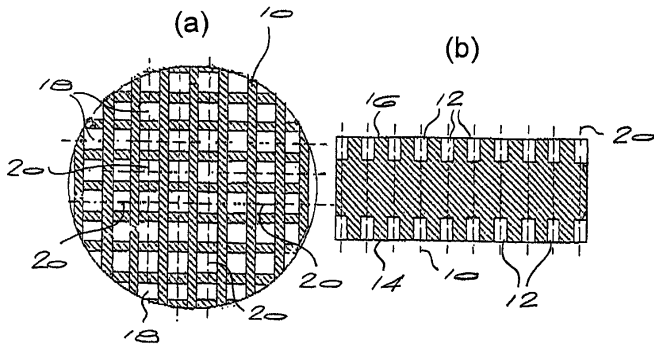

(tool insert)

(abrasive compact)

PCD

(cemented carbide)

PCBN

4,807,402

0 714 719

1 2

4,807,402

가

US 5,676,496
CD PCBN

P

5,598,621

5,813,105

(sintered multicornered insert)

가

2

가 , PCD PCBN , PCBN 가
 100mm 가 , 1.6mm 30mm, 55mm 125mm, 2mm 10mm 80mm
 가

, 60 가 3 가

가

1 (a) , (b) (a) , (c)
 2 8 , (a) , (b)
 , (c)

1 (10) (12) 가 (14, 16) (18) 1 (a) (12) 가
 (10) (18) /

(10) (16) (20) (14) (22) (26) 1 (c) (22) (24)

(10) (10) , (18) , PCBN 가 (10) , (18) 가
 / 가 / 가 , 1 (a) (b) 가

가 가 , 가 (10)가 , /

2 1 , 2 (c) ,

가 3 가 (40) (44, 46)

(42) 가 (42) (48) (42)

(48) (50, 52) (40) (5)

0) , (52) (48) (56) 3c

(60) (58)

4 3 , 가 (42) 4

(c) (50, 52)

5 4 , 가 ,

, 5 (c) , 90 4 1 2

(50a, 50b) (52a, 52b)

6 3 , 가 (42) 6 (c

(50, 51, 52) (50, 51, 52)

7 3 , (40) (48) 7 (a) (6

2) (64) 60 가 3 (66)

(68)

8b (72, 74) (70)

가 (78) (72, 74) (76) (76)

, 8c (82) (8b 가) (80) (70)

(88) (86) (88) (84)가

(84)

(chip breaker)

가

(57)

1. (tool insert)

rasive) , (superab

1 2.

(cemented carbide),

1 3.

2

(abrasive compact)

3 4.

PCD PCBN

1 5.

4

5 6.

55mm 125mm , 1.6mm 30mm

6 7.

80mm 100mm , 2mm 10mm

1 8.

7

9.

9 10. ,

10 11. ,

9 12. ,

11 13. ,
60 가 3

13 14. ,
3

15. ,

, ,
,

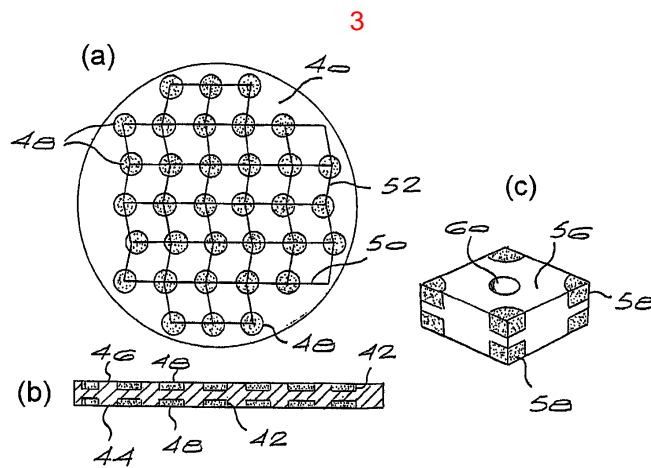
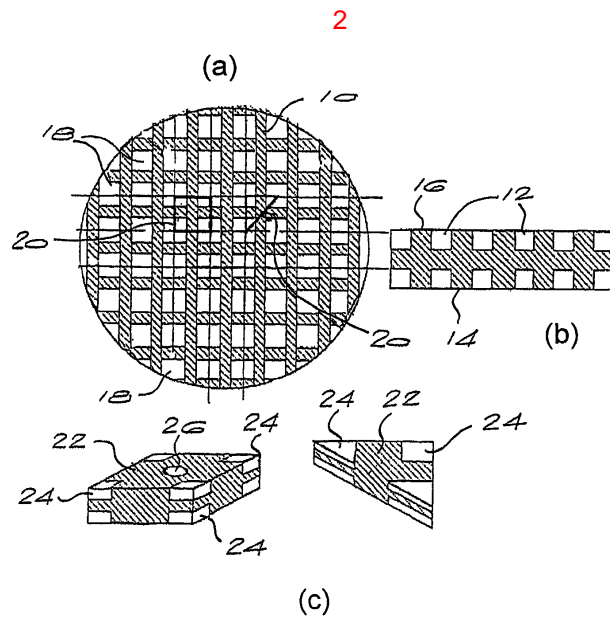
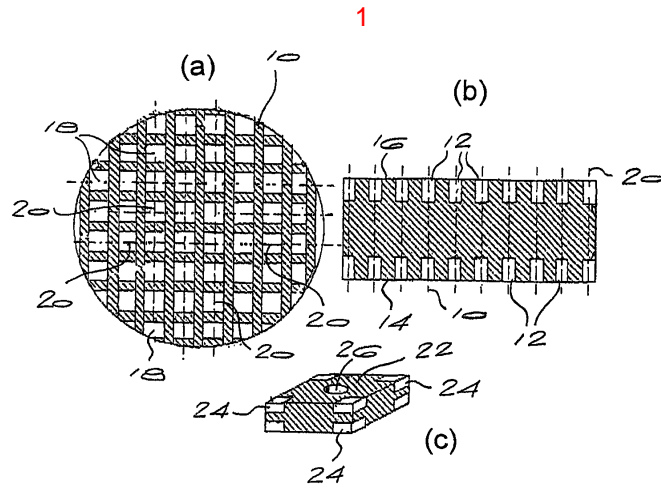

4

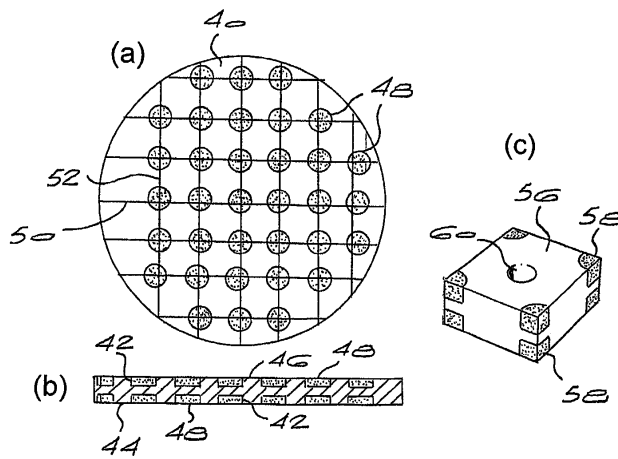

5

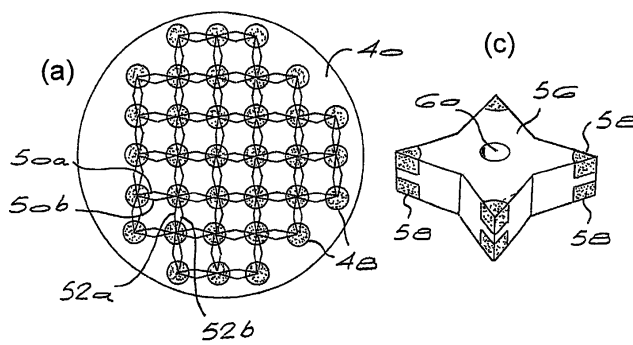

6

