



US00D564426S

(12) **United States Design Patent** (10) **Patent No.:** **US D564,426 S**
Okue (45) **Date of Patent:** **** Mar. 18, 2008**

(54) **REAR BUMPER FOR AN AUTOMOBILE**

OTHER PUBLICATIONS

(75) Inventor: **Masaki Okue**, Toyota (JP)
(73) Assignee: **Toyota Jidosha Kabushiki Kaisha** (JP)
(**) Term: **14 Years**

Toyota, Belta, Brochure of Belta, Nov. 2005, Toyota Jidosha Kabushiki Kaisha.
AUDI, A4, Car and Driver, Mar. 26, 2005, Diamond, Inc.

* cited by examiner

(21) Appl. No.: **29/285,031**
(22) Filed: **Mar. 19, 2007**

Primary Examiner—Melody N. Brown
(74) *Attorney, Agent, or Firm*—SAIDMAN DesignLaw Group

(30) **Foreign Application Priority Data**
Sep. 27, 2006 (JP) 2006-025891

(57) **CLAIM**

The ornamental design for a rear bumper for an automobile, as shown and described.

(51) **LOC (8) Cl.** **12-16**
(52) **U.S. Cl.** **D12/169**
(58) **Field of Classification Search** D12/90-92,
D12/86, 169, 196, 163; 296/193.1, 181.1;
293/102, 113, 115, 117, 120
See application file for complete search history.

DESCRIPTION

FIG. 1 is a front perspective view of a rear bumper for an automobile showing my new design;
FIG. 2 is a front view thereof;
FIG. 3 is a rear view thereof;
FIG. 4 is a right-side view thereof;
FIG. 5 is a left-side view thereof;
FIG. 6 is a top view thereof; and,
FIG. 7 is a bottom view thereof.

(56) **References Cited**

U.S. PATENT DOCUMENTS

D535,232 S * 1/2007 Miyata et al. D12/169
D540,223 S * 4/2007 Sumigama D12/169
D545,733 S * 7/2007 Hamano D12/169
D550,130 S * 9/2007 Lamarre D12/169

1 Claim, 3 Drawing Sheets

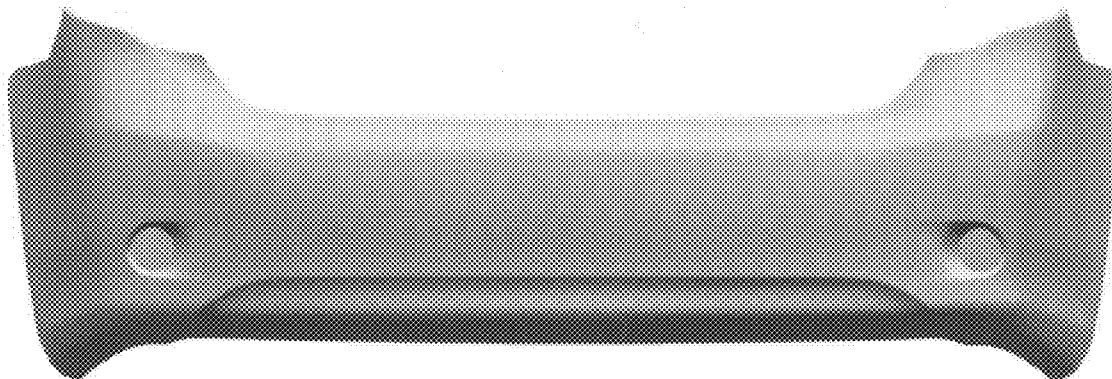

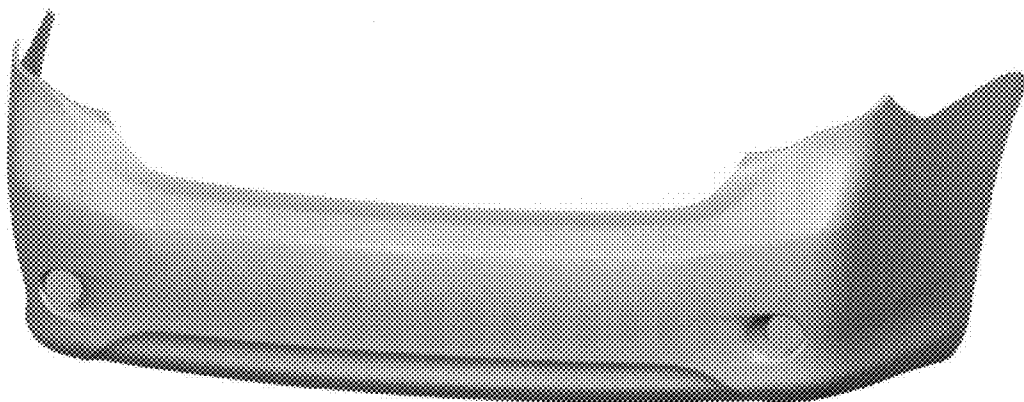

FIG. 1

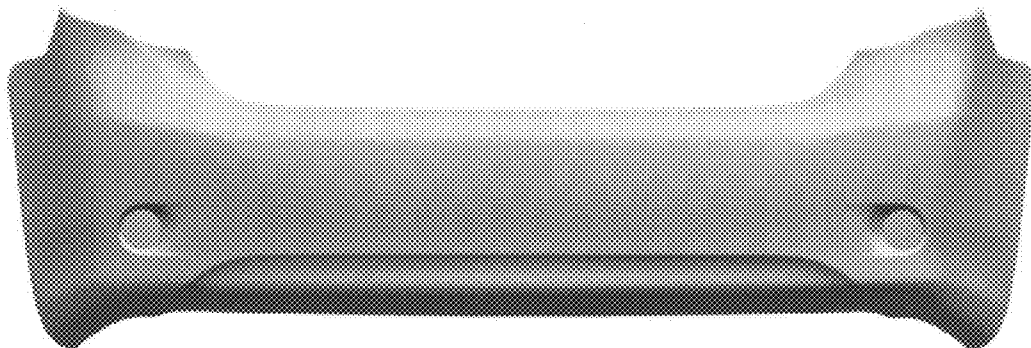

FIG. 2

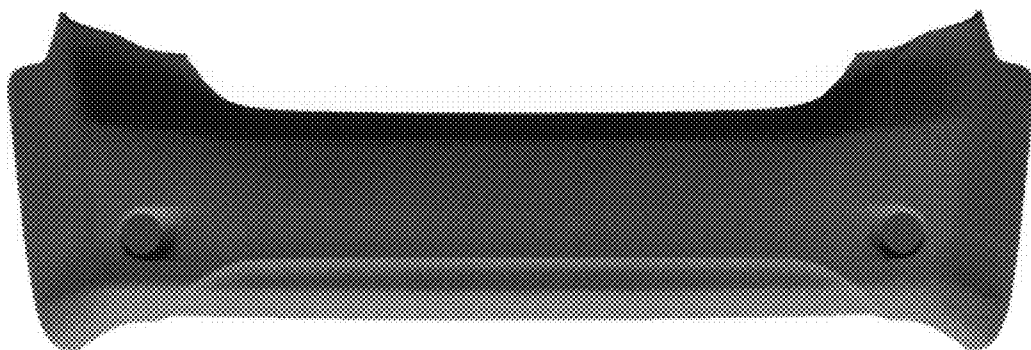

FIG. 3

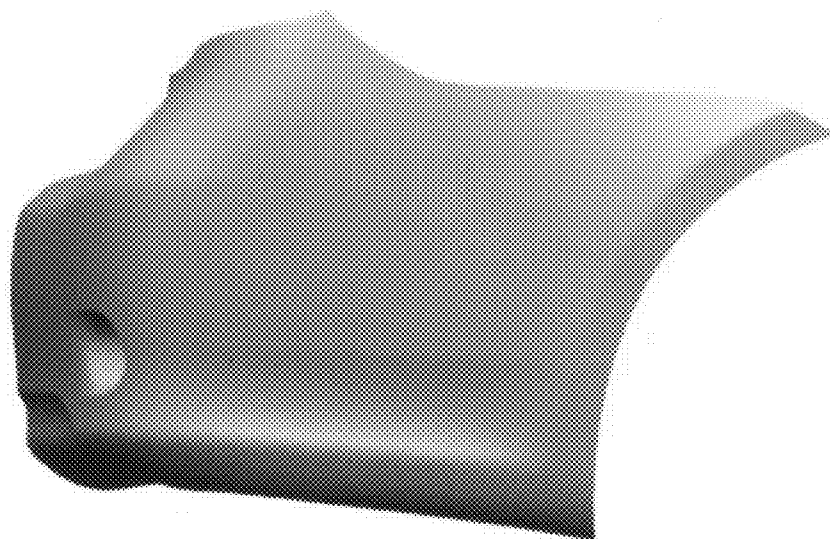

FIG. 4

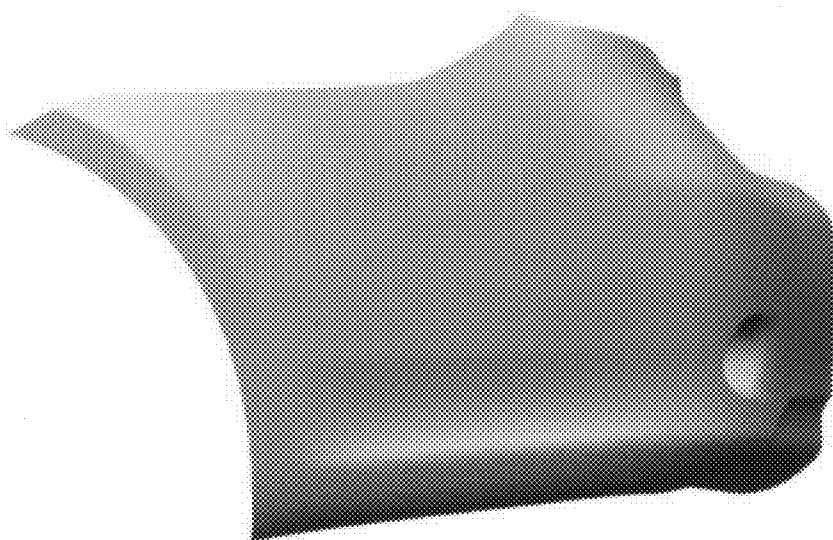

FIG. 5

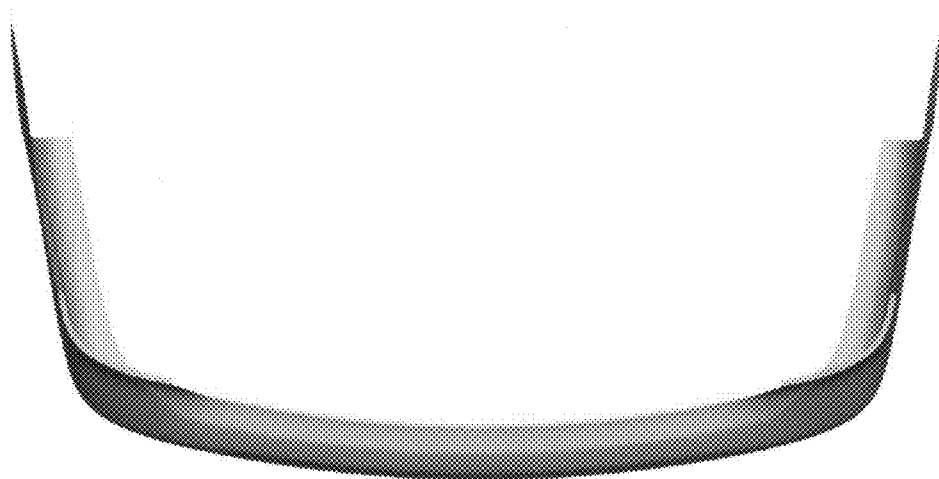

FIG. 6

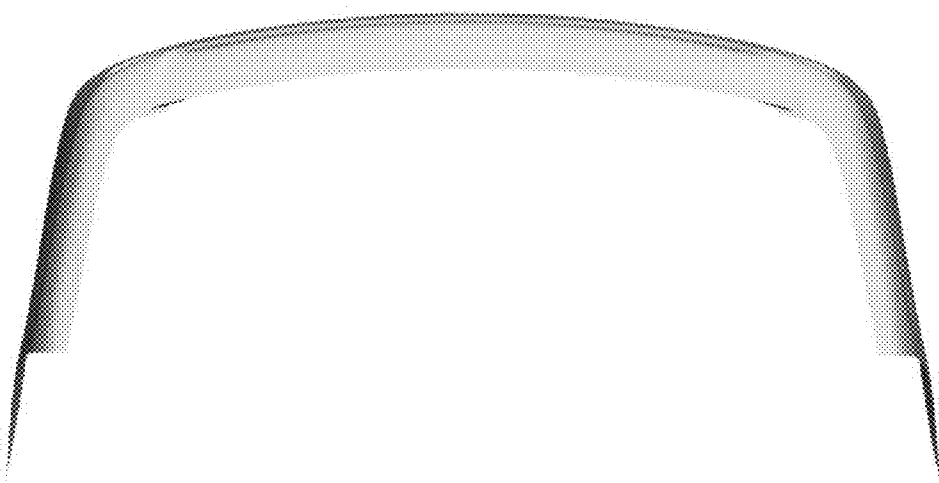

FIG. 7