

(19) World Intellectual Property Organization  
International Bureau



(43) International Publication Date  
14 January 2010 (14.01.2010)

PCT

(10) International Publication Number  
**WO 2010/005810 A2**

- (51) International Patent Classification:  
*G02B 5/12* (2006.01)      *G02B 6/00* (2006.01)
- (21) International Application Number:  
PCT/US2009/048876
- (22) International Filing Date:  
26 June 2009 (26.06.2009)
- (25) Filing Language: English
- (26) Publication Language: English
- (30) Priority Data:  
61/079,639      10 July 2008 (10.07.2008)      US  
61/114,865      14 November 2008 (14.11.2008)      US  
61/169,973      16 April 2009 (16.04.2009)      US  
61/176,672      8 May 2009 (08.05.2009)      US

- (72) Inventors; and
- (75) Inventors/Applicants (for US only): **SHERMAN, Audrey, A.** [US/US]; 3M Center, Post Office Box 33427, Saint Paul, MN 55133-3427 (US). **BOULOS, Marie, A.** [US/US]; 3M Center, Post Office Box 33427, Saint Paul, MN 55133-3427 (US). **SCHAFFER, Kevin, R.** [US/US]; 3M Center, Post Office Box 33427, Saint Paul, MN 55133-3427 (US). **MEIS, Michael, A.** [US/US]; 3M Center, Post Office Box 33427, Saint Paul, MN 55133-3427 (US). **TRAN, Thu-van, T.** [US/US]; 3M Center, Post Office Box 33427, Saint Paul, MN 55133-3427 (US). **AELING, Ellen, O.** [US/US]; 3M Center, Post Office Box 33427, Saint Paul, MN 55133-3427 (US). **WIDAGDO, Soemantri** [US/US]; 3M Center, Post Office Box 33427, Saint Paul, MN 55133-3427 (US).

(71) Applicant (for all designated States except US): **3M INNOVATIVE PROPERTIES COMPANY** [US/US]; 3m Center, Post Office Box 33427, Saint Paul, MN 55133-3427 (US).

(81) Designated States (unless otherwise indicated, for every kind of national protection available): AE, AG, AL, AM, AO, AT, AU, AZ, BA, BB, BG, BH, BR, BW, BY, BZ, CA, CH, CL, CN, CO, CR, CU, CZ, DE, DK, DM, DO, DZ, EC, EE, EG, ES, FI, GB, GD, GE, GH, GM, GT, HN, HR, HU, ID, IL, IN, IS, JP, KE, KG, KM, KN, KP, KR, KZ, LA, LC, LK, LR, LS, LT, LU, LY, MA, MD,

[Continued on next page]

(54) Title: RETROREFLECTIVE ARTICLES AND DEVICES HAVING VISCOELASTIC LIGHTGUIDE

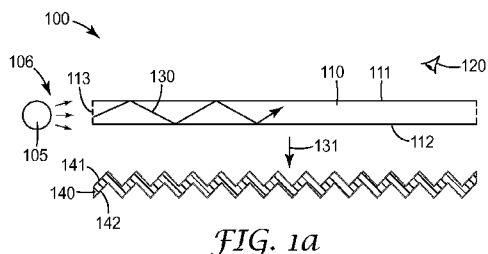

FIG. 1a

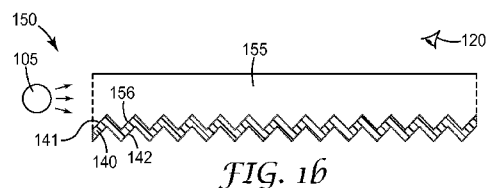

FIG. 1b

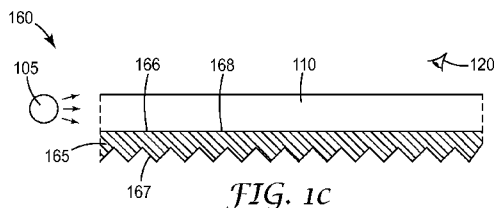

FIG. 1c

(57) Abstract: Disclosed herein is an optical device having a light source, a viscoelastic lightguide and a retroreflective film suitable for retroreflecting light. Light from the light source enters the viscoelastic lightguide and is transported within the lightguide by total internal reflection. The transported light is extracted from the lightguide and retroreflected at a structured surface of the retroreflective film. The optical device may have a "front lit" or a "back lit" configuration depending on the relative positioning of the lightguide and the retroreflective film. The retroreflective film may include prismatic retroreflective sheeting, holographic film or film structured with diffraction gratings. The optical device may be used, for example, as a sign or marking, a license plate assembly, a tail light assembly for vehicles, a security laminate for protection of documents against tampering, or an illumination device.



WO 2010/005810 A2

ME, MG, MK, MN, MW, MX, MY, MZ, NA, NG, NI, NO, NZ, OM, PE, PG, PH, PL, PT, RO, RS, RU, SC, SD, SE, SG, SK, SL, SM, ST, SV, SY, TJ, TM, TN, TR, TT, TZ, UA, UG, US, UZ, VC, VN, ZA, ZM, ZW.

**(84) Designated States** (unless otherwise indicated, for every kind of regional protection available): ARIPO (BW, GH, GM, KE, LS, MW, MZ, NA, SD, SL, SZ, TZ, UG, ZM, ZW), Eurasian (AM, AZ, BY, KG, KZ, MD, RU, TJ, TM), European (AT, BE, BG, CH, CY, CZ, DE, DK, EE, ES, FI, FR, GB, GR, HR, HU, IE, IS, IT, LT, LU, LV, MC, MK, MT, NL, NO, PL, PT, RO, SE, SI, SK, TR), OAPI (BF, BJ, CF, CG, CI, CM, GA, GN, GQ, GW, ML, MR, NE, SN, TD, TG).

**Declarations under Rule 4.17:**

- as to applicant's entitlement to apply for and be granted a patent (Rule 4.17(ii))
- as to the applicant's entitlement to claim the priority of the earlier application (Rule 4.17(iii))

**Published:**

- without international search report and to be republished upon receipt of that report (Rule 48.2(g))

## RETROREFLECTIVE ARTICLES AND DEVICES HAVING VISCOELASTIC LIGHTGUIDE

### Field

5           This disclosure relates to optical articles and devices, particularly those that are retroreflective. The optical articles and devices include lightguides made with viscoelastic materials.

### Background

10           Retroreflective films are characterized by the ability to reflect incident light back toward an originating light source. Cube corner retroreflective sheeting, sometimes referred to as “prismatic” retroreflective sheeting, typically comprises a thin transparent layer having a substantially planar first surface and a second structured surface comprising a plurality of cube corner elements. Each cube corner element is formed by three  
15           reflecting faces at the surface of the thin transparent layer. Light incident upon a reflecting surface can undergo a number of additional reflections before being directed back toward the light source. Prismatic retroreflective sheeting may be used in traffic safety applications, such as for license plates, road signs, barricades, pavement markers and marking tape, as well as for personal safety applications including tape for clothing,  
20           headgear, vehicles and the like. Prismatic retroreflective sheeting may be used to provide signage in graphic arts applications.

            Prismatic retroreflective sheeting is known for being able to reflect a large portion of incident light back towards an originating light source. Without a light source, however, prismatic retroreflective sheeting can be difficult to see under some conditions.

25           Lightguides are used to facilitate distribution of light from a light source over an area much larger than the light source. Lightguides comprise optically transmissive materials and may have different forms such as slab, wedge, and pseudo-wedge forms. Most lightguides are designed to accept light at an edge surface and allow this light to propagate by total internal reflection between a back surface and an output surface, toward  
30           an opposing edge surface from which the light enters. Light is emitted uniformly from the

output surface using extracting features that are positioned in various types of patterns on the output surface.

### Summary

5 Disclosed herein is an optical device having a light source, a viscoelastic lightguide and a retroreflective film suitable for retroreflecting light. Light from the light source enters the viscoelastic lightguide and is transported within the lightguide by total internal reflection. The optical device may have a “front lit” configuration such that the transported light is extracted from the lightguide and retroreflected at a structured surface  
10 of the retroreflective film. The optical device may have a “back lit” configuration such that the transported light is extracted from the lightguide and transmitted through the retroreflective film. Retroreflection at the structured surface may comprise reflection by refraction or reflection by diffraction depending on the particular construction of the optical device.

15 The retroreflective film may comprise prismatic retroreflective sheeting such as that used in traffic signs and markings. The retroreflective film may also comprise a holographic film or a film structured with diffraction gratings.

The optical device may be used as, for example, a sign or marking, a license plate assembly, a tail light assembly for vehicles, a security laminate for protection of  
20 documents against tampering, or an illumination device.

These and other aspects of the invention are described in the detailed description below. In no event should the above summary be construed as a limitation on the claimed subject matter which is defined solely by the claims as set forth herein.

### 25 Brief Descriptions of Drawings

Advantages and features of the invention may be more completely understood by consideration of the following figures in connection with the detailed description provided below. The figures are schematic drawings of various articles and are not necessarily drawn to scale.

30 FIGS. 1a-d, 2 and 3a-b show schematic cross sections of exemplary devices having front lit configurations.

FIGS. 4a-b and 5-9 show schematic cross sections of exemplary devices having back lit configurations.

### Detailed Description

5 This disclosure relates to U.S. Provisional Application Nos. 61/079639 filed on July 10, 2008 (64347US002, Sherman et al.); 61/087387 filed on August 8, 2008 (64691US002, Sherman et al.); 61/114865 filed on November 14, 2008 (64347US003, Sherman et al.); 61/114849 filed on November 14, 2008 (64691US003, Sherman et al.); and 61/169973 filed on April 16, 2009 (64347US008, Sherman et al.); all incorporated  
10 herein by reference.

The optical device disclosed herein includes a light source that emits light, a viscoelastic layer for managing the light and a retroreflective film for redirecting the light back in the general direction of the light source. Optical article refers to the corresponding optical device without the light source.

15 The optical device may provide one or more advantages. For example, the viscoelastic lightguide is generally soft and compliant such that the light source may be easily coupled to the lightguide so that light can enter the lightguide. In some embodiments, the viscoelastic lightguide comprises a PSA which is generally tacky at room temperature. The light source may then be coupled to the viscoelastic lightguide  
20 such that it is adhered to the lightguide. This may facilitate assembly of the optical device itself or constructions in which the device is used.

Light is typically extracted from the viscoelastic lightguide at one or more desired locations or areas of the lightguide. In some embodiments, an extractor layer may be used to extract light from the viscoelastic lightguide. Again, due to the soft and compliant  
25 properties of the viscoelastic lightguide, the extractor layer may be easily coupled to the lightguide so that light can enter the layer. If the viscoelastic lightguide comprises a PSA, the extractor layer can be directly adhered to the lightguide without the need for additional materials to bond the two together. Light from the extractor layer can then be  
30 retroreflected by the retroreflective film such that the optical article is lit up by light originating from the light source.

In some embodiments, the retroreflective film may be used to extract light from the viscoelastic lightguide. Again, due to the soft and compliant properties of the viscoelastic lightguide, the retroreflective film may be easily coupled to the lightguide so that light can enter the retroreflective film. If the viscoelastic lightguide comprises a PSA, the retroreflective film can be directly adhered to the lightguide without the need for additional materials to bond the two together. Light from the viscoelastic lightguide can then be retroreflected by the retroreflective film such that the optical article is lit up by light originating from the light source.

The optical device may be used to provide light anywhere it is desired. The optical device may be designed for interior and/or exterior use. The optical device may be designed for household, commercial and/or industrial use. The optical device may be used and/or provided in a construction so that it is portable, i.e., it is a portable source of light. Lighted cards, tapes, signs, labels, stickers, cut-outs, etc. are examples of portable constructions that may be made using the optical device. The optical device may also be used and/or provided in a more stationary construction such as in a license plate assembly or as part of a lighting assembly used to provide lighting on the exterior of a vehicle, e.g., for tail lights, replacing tail light cavities and their lighting assemblies and which are very space consuming. The optical device may also be used to provide "light on demand", e.g., the light source may be activated selectively when certain conditions are met.

The optical device may also be very adaptable, even by a user, so that it can be used in different lighting forms and constructions. For example, optical articles may be provided in roll or sheet form that can be cut into various shapes and sizes. The light source may be interchangeable with the optical article, for example, if the light source should become unusable or if a different color of light is desired. Further, if used in a sign construction, graphics can be interchanged, for example, if one would like to update an advertisement. The optical device can be used with a variety of retroreflective films, and the films can be either front lit or back lit relative to the position of a viewer.

The optical device may provide many more advantages. The optical device can be used to provide light that is bright, diffuse, uniform and/or concentrated over particular areas. The optical device may provide advantages by being thin, flexible and/or lightweight. The viscoelastic lightguide may be tiled to light large areas of retroreflective

film which may be made easier if the lightguides can be stuck together. Due to its viscoelastic properties, the viscoelastic lightguide may also dampen stresses experienced by the optical device or construction in which the device is used. The viscoelastic lightguide, when disposed on a substrate, may be removable and/or repositionable over  
5 time. The optical device may also provide advantages related to cost, because it can be made from commercially available light sources, viscoelastic materials and retroreflective films. Additional advantages are described below.

The behavior of light with respect to the optical devices and articles disclosed herein can be described using principles of geometric optics. These principles are well  
10 known and are not presented here; a more detailed description can be found in the Sherman et al. references cited above. In general, one may apply the law of refraction and the principle of total internal reflection in conjunction with ray tracing techniques to determine theoretically how varying three dimensional structure, material composition, layer construction, angular distribution of light, etc. can affect the behavior of light for the  
15 optical devices and articles disclosed herein.

#### *Front Lit Configuration*

FIG. 1a shows a schematic cross section of exemplary optical device 100. This embodiment is an example of a front lit configuration in which viscoelastic lightguide 110  
20 is on top of retroreflective film 140 or closer than the retroreflective film to the viewer as indicated by eye 120. Light source 105 is positioned relative to viscoelastic lightguide 110 such that light emitted by the light source enters viscoelastic lightguide 110 and is transported within the layer by total internal reflection. Light emitted by the light source is represented by rays 106 which enter viscoelastic lightguide 110 through input surface  
25 113 adapted to receive light from the light source. Light within the viscoelastic lightguide is represented by single ray 130 which is transported by total internal reflection. At least a portion of the viscoelastic lightguide has optically smooth surface 111 and/or 112.

Light emitted by the light source enters the viscoelastic lightguide and is transported within the lightguide by total internal reflection. In general, total internal  
30 reflection occurs when light having a particular angular component or distribution is incident upon an interface at one or more angles greater than the critical angle  $\theta_c$ . An

optically smooth surface, as used herein, means that the surface is smooth enough such that light incident upon the surface is not affected undesirably by the surface, e.g., the surface is free of defects having at least one dimension larger than the wavelength of the incident light. The optically smooth surface allows at least some of the light entering the viscoelastic lightguide to be reflected at the surface such that this light continues to propagate within the layer according to the principle of total internal reflection. For reflection of light incident on an optically smooth surface, the observed reflection angle is within about  $10^\circ$  of the calculated reflection angle. Total internal reflection occurs if a predetermined amount, or at least within about 10% of a predetermined amount, of light does not escape the viscoelastic lightguide unless it is intentionally extracted from the lightguide.

Exemplary optical device 100 further comprises retroreflective film 140 having upper structured surface 141 and lower structured surface 142. Light propagating within the viscoelastic lightguide may be extracted, as shown by ray 131, from the lightguide and retroreflected from either structured surface of retroreflective film 140.

The viscoelastic lightguide may not be in direct contact with the retroreflective film. One or more layers may be disposed between the viscoelastic lightguide and the retroreflective film depending on the desired effect. Embodiments in which the viscoelastic lightguide and the retroreflective film are not in contact are described below.

The viscoelastic lightguide may be in direct contact with the retroreflective film. FIG. 1b shows a schematic cross section of exemplary optical device 150 having a front lit configuration. In this embodiment, viscoelastic lightguide 155 is in direct contact with retroreflective film 140 such that interface 156 is formed. FIG. 1c shows a schematic cross section of another exemplary optical device 160 having a front lit configuration. In this embodiment, viscoelastic lightguide 110 is in direct contact with retroreflective film 165 such that interface 168 is formed.

The viscoelastic lightguide may have opposing major surfaces that are substantially unstructured as shown in FIGS. 1a and 1c. These major surfaces may also be structured with a plurality of features, or one major surface may be substantially unstructured and the other structured with a plurality of features. In FIG. 1b, the surface of the viscoelastic lightguide at interface 156 is structured with a plurality of features.



FIG. 1d shows a schematic cross section of exemplary optical device 170 having a front lit configuration. In this embodiment, viscoelastic lightguide 175 is not in direct contact with retroreflective film 140. Viscoelastic lightguide 175 comprises upper structured surface 176 and lower surface 177.

5           A structured surface of the viscoelastic lightguide comprises a plurality of features which may include protrusions and/or depressions having lenticular, prismatic, ellipsoidal, conical, parabolic, pyramidal, square, or rectangular shapes, or a combination thereof. Features comprising lenses (as shown for surface 176 in FIG. 1d) are particularly useful for directing light to a preferred angular distribution. Features comprising linear prisms or  
10 elongated prisms (as shown for surface 141 in FIG. 1b) are also particularly useful. Other exemplary features comprise protrusions and/or depressions having elongated, irregular, variably sloped lenticular, or random columnar shapes, or a combination thereof. Hybrids of any combination of shapes may be used, for example, elongated parabolic, pyramidal prismatic, rectangular-based prismatic, and rounded-tip prismatic shapes. The features  
15 may comprise random combinations of shapes.

Sizes of the features may be described by their overall shapes in three dimensions. In some embodiments, each feature may have a dimension of from about 1 to about 100  $\mu\text{m}$ , for example, from about 5 to about 70  $\mu\text{m}$ . The features of a surface may have all the  
20 same shape, but the sizes of the shapes may vary in at least one dimension. The features of a surface may have different shapes, and the sizes of these features may or may not vary in any given dimension.

Surface structures of the features may also be varied. Surface structure of a feature generally refers to the sub-structure of the feature. Exemplary surface structures include optically smooth surfaces, irregular surfaces, patterned surfaces, or a combination thereof.  
25 For a given surface having a plurality of features, all or some of the features may have the same surface structure, or they may all be different. The surface structure of a feature may vary over portions of the feature. An optically smooth surface of a feature may form part of the optically smooth surface of the viscoelastic lightguide. The optically smooth surfaces of the feature and the viscoelastic lightguide may be continuous or discontinuous  
30 with each other. If a plurality of features is used, the surfaces of some features may be completely optically smooth or some may be partially optically smooth.

The number of features, if used, for a given structured surface is at least one. A plurality of features, meaning at least two, may also be used. In general, any number of features may be included, e.g., 0, 1, 2, 3, 4 or 5 features; greater than 1, greater than 10, greater than 20, greater than 30, greater than 40, greater than 50, greater than 100, greater than 200, greater than 500, greater than 1000, or greater than 2000 features; or from about 1 to about 10, from about 1 to about 20, from about 1 to about 30, from about 1 to about 40, from about 1 to about 50, from about 1 to about 100, from about 1 to about 200, from about 1 to about 500, from about 1 to about 1000, or from about 1 to about 2000 features.

The features may be randomly arranged, arranged in some type of regular pattern, or both. The distance between features may also vary. The features may be discreet or they may overlap. The features may be arranged in close proximity to one another, in substantial contact with each other, immediately adjacent each other, or some combination thereof. A useful distance between features is up to about 10  $\mu\text{m}$ , or from about 0.05  $\mu\text{m}$  to about 10  $\mu\text{m}$ . The features may be offset with respect to one another, angularly as well as transversely. The areal density of the features may change over the length, width, or both.

The features may be used to control the amount and/or direction of light that is extracted from the retroreflective film. The features may be arranged to obtain a desired optical effect. The features may be arranged to provide an image, extract light uniformly or as a gradient from the viscoelastic lightguide, hide discrete light sources, or reduce Moiré. This can be carried out generally by varying the shape, size, surface structure, and/or orientation of the features. If a plurality of features is used, then the number and/or arrangement of the features may be varied, as well as the orientation of the features relative to each other.

The shape of a feature may change the angular component of light which can increase or decrease the amount of light that is extracted from the viscoelastic layer. This may be the case if light propagates by total internal reflection within the viscoelastic lightguide and strikes a surface of a feature at an angle less than, equal to, or greater than the critical angle for the viscoelastic lightguide and an adjacent substrate which may or may not be the retroreflective film. The amount of light that is extracted from from the viscoelastic lightguide may increase or decrease accordingly. The size of a feature may be

changed such that more or less light can reflect off a surface of the feature, thus increasing or decreasing the amount of light that is extracted from the viscoelastic layer. The surface structure of a feature may be used to control the distribution of light that is extracted from the viscoelastic layer. Light having a particular angular distribution may strike a feature and be extracted uniformly and/or randomly. Light may also be extracted uniformly and in a pattern, or randomly and in a pattern.

The viscoelastic lightguide is generally in contact with at least one medium. The medium may comprise air or a substrate, and substrates may be the retroreflective film, polymeric film, metal, glass, and/or fabric. Particular substrates are described below for a variety of exemplary constructions. For the purpose of convenience, a viscoelastic lightguide in contact with a substrate is described below, but this substrate may comprise any type of medium including air.

Given a particular retroreflective film or substrate in contact with the viscoelastic lightguide, the amount of light extracted from the lightguide and by the substrate may be from about 10 to about 50%, from about 20 to about 50%, from about 30 to about 50%, from about 50 to about 70%, from about 50 to about 80%, or from about 10 to about 90% relative to the total amount of light that enters the lightguide.

The transmittance angle for light extracted from the viscoelastic lightguide by the retroreflective film or substrate may be from greater than about  $5^\circ$  to less than about  $95^\circ$ , greater than about  $5^\circ$  to less than about  $60^\circ$ , or greater than about  $5^\circ$  to less than about  $30^\circ$ .

The viscoelastic lightguide may have a refractive index greater than that of the retroreflective film or the substrate. The refractive index of the viscoelastic lightguide may be greater than about 0.002, greater than about 0.005, greater than about 0.01, greater than about 0.02, greater than about 0.03, greater than about 0.04, greater than about 0.05, greater than about 0.1, greater than about 0.2, greater than about 0.3, greater than about 0.4, or greater than about 0.5, as compared to the refractive index of the retroreflective film or substrate.

The viscoelastic lightguide may have a refractive index less than that of the retroreflective film or substrate. The refractive index of the viscoelastic lightguide may be less than about 0.002, less than about 0.005, less than about 0.01, less than about 0.02, less than about 0.03, less than about 0.04, less than about 0.05, less than about 0.1, less than

about 0.2, less than about 0.3, less than about 0.4, or less than about 0.5, as compared to the refractive index of the retroreflective film or substrate.

The viscoelastic lightguide and the retroreflective film or substrate may have the same or nearly the same refractive index such that light can be extracted into the retroreflective film or substrate with little or no change to the light. The refractive index difference of the viscoelastic lightguide and the retroreflective film or substrate may be from about 0.001 to less than about 0.002.

The refractive index difference of the viscoelastic lightguide and the retroreflective film or substrate may be from about 0.002 to about 0.5, from about 0.005 to about 0.5, from about 0.01 to about 0.5, from about 0.02 to about 0.5, from about 0.03 to about 0.5, from about 0.04 to about 0.5, from about 0.05 to about 0.5, from about 0.1 to about 0.5, from about 0.2 to about 0.5, from about 0.3 to about 0.5, or from about 0.4 to about 0.5.

The viscoelastic lightguide may have any bulk three-dimensional shape as is needed for a given application. The viscoelastic lightguide may be in the form of a square or rectangular layer, sheet, film, etc. The viscoelastic lightguide may be cut or divided into shapes as described below.

The thickness of the viscoelastic lightguide is not particularly limited as long as it can function as desired. The thickness of the viscoelastic lightguide may be selected based on or in conjunction with the light source. For example, design parameters may limit or even require that a particular light source(s) be used, and there may be a minimum amount, or range of amounts, of light that is required to enter the viscoelastic lightguide. Thus, the thickness of the viscoelastic lightguide may be selected so that the required amount of light from a given light source can enter the lightguide. A maximum thickness of the viscoelastic lightguide may be required for use in optical devices designed to be particularly thin. Exemplary thicknesses for the viscoelastic lightguide range from about 0.4 mil to about 1000 mil, from about 1 mil to about 300 mil, from about 1 mil to about 60 mil, or from about 0.5 mil to about 30 mil.

The amount and direction of light extracted from the viscoelastic lightguide may be controlled, at the very least, by the shape, size, number, arrangement, etc. of the features, the refractive indices of the viscoelastic lightguide and any medium with which the lightguide is in contact, the shape and size of the viscoelastic lightguide, and the

angular distribution of light that is allowed to enter the viscoelastic lightguide. These variables may be selected such that from about 10 to about 50%, from about 20 to about 50%, from about 30 to about 50%, from about 50 to about 70%, from about 50 to about 80%, or from about 10 to about 90% of light is extracted from the viscoelastic lightguide relative to the total amount of light that enters the lightguide.

The viscoelastic lightguide comprises one or more viscoelastic materials. In general, viscoelastic materials exhibit both elastic and viscous behavior when undergoing deformation. Elastic characteristics refer to the ability of a material to return to its original shape after a transient load is removed. One measure of elasticity for a material is referred to as the tensile set value which is a function of the elongation remaining after the material has been stretched and subsequently allowed to recover (destretch) under the same conditions by which it was stretched. If a material has a tensile set value of 0%, then it has returned to its original length upon relaxation, whereas if the tensile set value is 100%, then the material is twice its original length upon relaxation. Tensile set values may be measured using ASTM D412. Useful viscoelastic materials may have tensile set values of greater than about 10%, greater than about 30%, or greater than about 50%; or from about 5 to about 70%, from about 10 to about 70%, from about 30 to about 70%, or from about 10 to about 60%.

Viscous materials that are Newtonian liquids have viscous characteristics that obey Newton's law which states that stress increases linearly with shear gradient. A liquid does not recover its shape as the shear gradient is removed. Viscous characteristics of useful viscoelastic materials include flowability of the material under reasonable temperatures such that the material does not decompose.

The viscoelastic lightguide may have properties that facilitate sufficient contact or wetting with at least a portion of a material designed to extract light from the lightguide, e.g., the retroreflective film or substrate, such that the viscoelastic lightguide and the retroreflective film are optically coupled. Light can then be extracted from the viscoelastic lightguide. The viscoelastic lightguide is generally soft, compliant and flexible. Thus, the viscoelastic lightguide may have an elastic modulus (or storage modulus  $G'$ ) such that sufficient contact can be obtained, and a viscous modulus (or loss

modulus  $G''$ ) such that the layer doesn't flow undesirably, and a damping coefficient ( $G''/G'$ ,  $\tan D$ ) for the relative degree of damping of the layer.

Useful viscoelastic materials may have a storage modulus,  $G'$ , of less than about 300,000 Pa, measured at 10 rad/sec and a temperature of from about 20 to about 22°C.

5 Useful viscoelastic materials may have a storage modulus,  $G'$ , of from about 30 to about 300,000 Pa, measured at 10 rad/sec and a temperature of from about 20 to about 22°C.

Useful viscoelastic materials may have a storage modulus,  $G'$ , of from about 30 to about 150,000 Pa, measured at 10 rad/sec and a temperature of from about 20 to about 22°C.

10 Useful viscoelastic materials may have a storage modulus,  $G'$ , of from about 30 to about 30,000 Pa, measured at 10 rad/sec and a temperature of from about 20 to about 22°C.

Useful viscoelastic materials may have a storage modulus,  $G'$ , of from about 30 to about 150,000 Pa, measured at 10 rad/sec and a temperature of from about 20 to about 22°C, and a loss tangent ( $\tan d$ ) of from about 0.4 to about 3. Viscoelastic properties of materials can be measured using Dynamic Mechanical Analysis according to, for example, ASTM

15 D4065, D4440, and D5279.

In some embodiments, the viscoelastic lightguide comprises a PSA layer as described in the Dalquist criterion line (as described in Handbook of Pressure Sensitive Adhesive Technology, Second Ed., D. Satas, ed., Van Nostrand Reinhold, New York, 1989.)

20 The viscoelastic lightguide may have a particular peel force or at least exhibit a peel force within a particular range. For example, the viscoelastic lightguide may have a 90° peel force of from about 50 to about 3000 g/in, from about 300 to about 3000 g/in, or from about 500 to about 3000 g/in. Peel force may be measured using a peel tester from IMASS.

25 In some embodiments, the viscoelastic lightguide comprises an optically clear lightguide having high light transmittance of from about 80 to about 100%, from about 90 to about 100%, from about 95 to about 100%, or from about 98 to about 100% over at least a portion of the visible light spectrum (about 400 to about 700 nm). In some embodiments, the viscoelastic lightguide has a haze value of less than about 5%, less than about 3%, or less than about 1%. In some embodiments, the viscoelastic lightguide has a haze value of from about 0.01 to less than about 5%, from about 0.01 to less than about

30

3%, or from about 0.01 to less than about 1%. Haze values in transmission can be determined using a haze meter according to ASTM D1003.

In some embodiments, the viscoelastic lightguide comprises an optically clear lightguide having high light transmittance and a low haze value. High light transmittance may be from about 90 to about 100%, from about 95 to about 100%, or from about 99 to about 100% over at least a portion of the visible light spectrum (about 400 to about 700 nm), and haze values may be from about 0.01 to less than about 5%, from about 0.01 to less than about 3%, or from about 0.01 to less than about 1%. The viscoelastic lightguide may also have a light transmittance of from about 50 to about 100%.

In some embodiments, the viscoelastic lightguide is hazy and diffuses light, particularly visible light. A hazy viscoelastic lightguide may have a haze value of greater than about 5%, greater than about 20%, or greater than about 50%. A hazy viscoelastic lightguide may have a haze value of from about 5 to about 90%, from about 5 to about 50%, or from about 20 to about 50%.

In some embodiments, the viscoelastic lightguide may be translucent in that it reflects and transmits light.

The viscoelastic lightguide may have a refractive index in the range of from about 1.3 to about 2.6, 1.4 to about 1.7, or from about 1.5 to about 1.7. The particular refractive index or range of refractive indices selected for the viscoelastic lightguide may depend on the overall design of the optical device and the particular application in which the device may be used.

The viscoelastic lightguide generally comprises at least one polymer. The viscoelastic lightguide may comprise at least one PSA. PSAs are useful for adhering together adherends and exhibit properties such as: (1) aggressive and permanent tack, (2) adherence with no more than finger pressure, (3) sufficient ability to hold onto an adherend, and (4) sufficient cohesive strength to be cleanly removable from the adherend. Materials that have been found to function well as pressure sensitive adhesives are polymers designed and formulated to exhibit the requisite viscoelastic properties resulting in a desired balance of tack, peel adhesion, and shear holding power. Obtaining the proper balance of properties is not a simple process. A quantitative description of PSAs can be found in the Dahlquist reference cited above.

Useful PSAs are described in detailed in the Sherman et al. references cited above. Only a brief description of useful PSAs is included here. Exemplary poly(meth)acrylate PSAs are derived from: monomer A comprising at least one monoethylenically unsaturated alkyl (meth)acrylate monomer and which contributes to the flexibility and tack of the PSA; and monomer B comprising at least one monoethylenically unsaturated free-radically copolymerizable reinforcing monomer which raises the Tg of the PSA and contributes to the cohesive strength of the PSA. Monomer B has a homopolymer glass transition temperature (Tg) higher than that of monomer A. As used herein, (meth)acrylic refers to both acrylic and methacrylic species and likewise for (meth)acrylate.

Preferably, monomer A has a homopolymer Tg of no greater than about 0°C. Preferably, the alkyl group of the (meth)acrylate has an average of about 4 to about 20 carbon atoms. Examples of monomer A include 2-methylbutyl acrylate, isooctyl acrylate, lauryl acrylate, 4-methyl-2-pentyl acrylate, isoamyl acrylate, sec-butyl acrylate, n-butyl acrylate, n-hexyl acrylate, 2-ethylhexyl acrylate, n-octyl acrylate, n-decyl acrylate, isodecyl acrylate, isodecyl methacrylate, and isononyl acrylate. The alkyl group can comprise ethers, alkoxy ethers, ethoxylated or propoxylated methoxy (meth)acrylates. Monomer A may comprise benzyl acrylate.

Preferably, monomer B has a homopolymer Tg of at least about 10°C, for example, from about 10 to about 50°C. Monomer B may comprise (meth)acrylic acid, (meth)acrylamide and N-monoalkyl or N-dialkyl derivatives thereof, or a (meth)acrylate. Examples of monomer B include N-hydroxyethyl acrylamide, diacetone acrylamide, N,N-dimethyl acrylamide, N,N-diethyl acrylamide, N-ethyl-N-aminoethyl acrylamide, N-ethyl-N-hydroxyethyl acrylamide, N,N-dihydroxyethyl acrylamide, t-butyl acrylamide, N,N-dimethylaminoethyl acrylamide, and N-octyl acrylamide. Other examples of monomer B include itaconic acid, crotonic acid, maleic acid, fumaric acid, 2,2-(diethoxy)ethyl acrylate, 2-hydroxyethyl acrylate or methacrylate, 3-hydroxypropyl acrylate or methacrylate, methyl methacrylate, isobornyl acrylate, 2-(phenoxy)ethyl acrylate or methacrylate, biphenyl acrylate, t-butylphenyl acrylate, cyclohexyl acrylate, dimethyladamantyl acrylate, 2-naphthyl acrylate, phenyl acrylate, N-vinyl formamide, N-vinyl acetamide, N-vinyl pyrrolidone, and N-vinyl caprolactam.



In some embodiments, the (meth)acrylate PSA is formulated to have a resultant T<sub>g</sub> of less than about 0°C and more preferably, less than about -10°C. Such (meth)acrylate PSAs include about 60 to about 98% by weight of at least one monomer A and about 2 to about 40% by weight of at least one monomer B, both relative to the total weight of the (meth)acrylate PSA copolymer.

Useful PSAs include natural rubber-based and synthetic rubber-based PSAs. Rubber-based PSAs include butyl rubber, copolymers of isobutylene and isoprene, polyisobutylene, homopolymers of isoprene, polybutadiene, and styrene/butadiene rubber. These PSAs may be inherently tacky or they may require tackifiers. Tackifiers include rosins and hydrocarbon resins.

Useful PSAs include thermoplastic elastomers. These PSAs include styrene block copolymers with rubbery blocks of polyisoprene, polybutadiene, poly(ethylene/butylene), poly(ethylene-propylene). Resins that associate with the rubber phase may be used with thermoplastic elastomer PSAs if the elastomer itself is not tacky enough. Examples of rubber phase associating resins include aliphatic olefin-derived resins, hydrogenated hydrocarbons, and terpene phenolic resins. Resins that associate with the thermoplastic phase may be used with thermoplastic elastomer PSAs if the elastomer is not stiff enough. Thermoplastic phase associating resins include polyaromatics, coumarone-indene resins, resins derived from coal tar or petroleum.

Useful PSAs include tackified thermoplastic-epoxy pressure sensitive adhesives as described in US 7,005,394 (Ylitalo et al.). These PSAs include thermoplastic polymer, tackifier and an epoxy component.

Useful PSAs include polyurethane pressure sensitive adhesive as described in US 3,718,712 (Tushaus). These PSAs include crosslinked polyurethane and a tackifier.

Useful PSAs include polyurethane acrylate as described in US 2006/0216523 (Shusuke). These PSAs include urethane acrylate oligomer, plasticizer and an initiator.

Useful PSAs include silicone PSAs such as polydiorganosiloxanes, polydiorganosiloxane polyoxamides and silicone urea block copolymers described in US 5,214,119 (Leir, et al). The silicone PSAs may be formed from a hydrosilylation reaction between one or more components having silicon-bonded hydrogen and aliphatic unsaturation. The silicone PSAs may include a polymer or gum and an optional tackifying

resin. The tackifying resin may comprise a three-dimensional silicate structure that is endcapped with trialkylsiloxy groups.

Useful silicone PSAs may also comprise a polydiorganosiloxane polyoxamide and an optional tackifier as described in US 7,361,474 (Sherman et al.) incorporated herein by  
5 reference. Useful tackifiers include silicone tackifying resins as described in US 7,090,922 B2 (Zhou et al.) incorporated herein by reference.

The PSA may be crosslinked to build molecular weight and strength of the PSA. Crosslinking agents may be used to form chemical crosslinks, physical crosslinks or a combination thereof, and they may be activated by heat, UV radiation and the like.

10 In some embodiments, the viscoelastic lightguide comprises a PSA formed from a (meth)acrylate block copolymer as described in U.S. 7,255,920 B2 (Everaerts et al.). In general, these (meth)acrylate block copolymers comprise: at least two A block polymeric units that are the reaction product of a first monomer composition comprising an alkyl methacrylate, an aralkyl methacrylate, an aryl methacrylate, or a combination thereof,  
15 each A block having a Tg of at least 50°C, the methacrylate block copolymer comprising from 20 to 50 weight percent A block; and at least one B block polymeric unit that is the reaction product of a second monomer composition comprising an alkyl (meth)acrylate, a heteroalkyl (meth)acrylate, a vinyl ester, or a combination thereof, the B block having a Tg no greater than 20°C, the (meth)acrylate block copolymer comprising from 50 to 80  
20 weight percent B block; wherein the A block polymeric units are present as nanodomains having an average size less than about 150 nm in a matrix of the B block polymeric units.

In some embodiments, the viscoelastic lightguide comprises a clear acrylic PSA, for example, those available as transfer tapes such as VHB™ Acrylic Tape 4910F from 3M Company and 3M™ Optically Clear Laminating Adhesives (8140 and 8180 series).

25 In some embodiments, the viscoelastic lightguide comprises a PSA formed from at least one monomer containing a substituted or an unsubstituted aromatic moiety as described in U.S. 6,663,978 B1 (Olson et al.).

In some embodiments, the viscoelastic lightguide comprises a copolymer as described in U.S. Serial No. 11/875194 (63656US002, Determan et al.), comprising (a)  
30 monomer units having pendant biphenyl groups and (b) alkyl (meth)acrylate monomer units.

In some embodiments, the viscoelastic lightguide comprises a copolymer as described in U.S. Provisional Application Serial No. 60/983735 (63760US002, Determan et al.), comprising (a) monomer units having pendant carbazole groups and (b) alkyl (meth)acrylate monomer units.

5 In some embodiments, the viscoelastic lightguide comprises an adhesive as described in U.S. Provisional Application Serial No. 60/986298 (63108US002, Schaffer et al.), comprising a block copolymer dispersed in an adhesive matrix to form a Lewis acid-base pair. The block copolymer comprises an AB block copolymer, and the A block phase separates to form microdomains within the B block/adhesive matrix. For example,  
10 the adhesive matrix may comprise a copolymer of an alkyl (meth)acrylate and a (meth)acrylate having pendant acid functionality, and the block copolymer may comprise a styrene-acrylate copolymer. The microdomains may be large enough to forward scatter incident light, but not so large that they backscatter incident light. Typically these microdomains are larger than the wavelength of visible light (about 400 to about 700 nm).  
15 In some embodiments the microdomain size is from about 1.0 to about 10  $\mu\text{m}$ .

The viscoelastic lightguide may comprise a stretch releasable PSA. Stretch releasable PSAs are PSAs that can be removed from a substrate if they are stretched at or nearly at a zero degree angle. In some embodiments, the viscoelastic lightguide or a stretch release PSA used in the viscoelastic lightguide has a shear storage modulus of less  
20 than about 10 MPa when measured at 1 rad/sec and  $-17^{\circ}\text{C}$ , or from about 0.03 to about 10 MPa when measured at 1 rad/sec and  $-17^{\circ}\text{C}$ . Stretch releasable PSAs may be used if disassembling, reworking, or recycling is desired.

In some embodiments, the stretch releasable PSA may comprise a silicone-based PSA as described in U.S. 6,569,521 B1 (Sheridan et al.) or U.S. Provisional Application  
25 Nos. 61/020423 (63934US002, Sherman et al.) and 61/036501 (64151US002, Determan et al.). Such silicone-based PSAs include compositions of an MQ tackifying resin and a silicone polymer. For example, the stretch releasable PSA may comprise an MQ tackifying resin and an elastomeric silicone polymer selected from the group consisting of urea-based silicone copolymers, oxamide-based silicone copolymers, amide-based silicone  
30 copolymers, urethane-based silicone copolymers, and mixtures thereof.

In some embodiments, the stretch releasable PSA may comprise an acrylate-based PSA as described in U.S. Provisional Application Nos. 61/141767 (64418US002, Yamanaka et al.) and 61/141827 (64935US002, Tran et al.) Such acrylate-based PSAs include compositions of an acrylate, an inorganic particle and a crosslinker. These PSAs can be a single or multilayer.

The viscoelastic lightguide may comprise an aerogel. An aerogel is a low-density solid state material derived from gel in which the liquid component of the gel has been replaced with air. Silica, alumina and carbon aerogels are exemplary aerogels that may be used.

The viscoelastic lightguide can optionally include one or more additives such as filler, particles, plasticizers, chain transfer agents, initiators, antioxidants, stabilizers, fire retardants, viscosity modifying agents, foaming agents, antistats, colorants such as dyes and pigments, fluorescent dyes and pigments, phosphorescent dyes and pigments, fibrous reinforcing agents, and woven and non-woven fabrics.

The viscoelastic lightguide may be made hazy and/or diffusive by including particles such as nanoparticles (diameter less than about 1  $\mu\text{m}$ ), microspheres (diameter 1  $\mu\text{m}$  or greater), or fibers. Exemplary nanoparticles include  $\text{TiO}_2$ . Haze and diffusive properties can also be incorporated into the viscoelastic lightguide by incorporating bubbles into the lightguide. The bubbles may have a diameter of from about 0.01 to about 1  $\mu\text{m}$ . Bubbles may be introduced by adding, e.g., foaming agents. Examples of additional additives that may be added to the viscoelastic lightguide include glass beads, reflective particles, and conductive particles. In some embodiments, the viscoelastic lightguide may comprise a PSA matrix and particles as described in U.S. Provisional Application No. 61/097685 (64740US002, Sherman et al.), comprising an optically clear PSA and silicon resin particles having a refractive index less than that of the PSA, and incorporated herein by reference. In some embodiments, the presence of particles, bubbles, air, etc. increases the scatter and uniformity of light.

In some embodiments, the viscoelastic lightguide provides an image. An image may be made by structuring a surface of the lightguide as described above. For example, surface 176 of FIG. 1d may be structured to provide the image. An image may be made by including or embedding material such as particles in the viscoelastic lightguide. The

image may also be made by forming an image on a surface of the lightguide, e.g., on surface 176. More than one surface of the lightguide may comprise an image. Surfaces of the viscoelastic lightguide may be imaged by printing or marking, e.g., by inkjet printing, laser printing, electrostatic printing and the like. Images may be monochrome such as black and white, or they may be colored. The materials used to form the images may reflect all or some light within a particular range of wavelengths, e.g., in the visible region. The materials used to form the images may function as color filters allowing light within a particular range of wavelengths, e.g., in the visible region, to be transmitted. Exemplary materials include colorants such as pigments and dyes.

In some embodiments, the viscoelastic lightguide provides an image by from holes in the lightguide. Holes may be made, e.g., by drilling through the lightguide.

The optical device comprises a retroreflective film. In general, a retroreflective film is suitable for retroreflecting light if light incident upon the film is reflected back in one or more useful directions relative to the direction of the incident light. Light may be reflected back in a direction that is  $180^\circ$  or nearly  $180^\circ$  from that of the incident light. Light may be reflected back in one or more directions that are anywhere between about  $45^\circ$  and about  $180^\circ$  relative to the direction of the incident light.

In general, light can be retroreflected meaning that the light can be reflected by refraction or reflected by diffraction. Light is reflected by refraction in the embodiments described thus far. In any of these embodiments, surfaces of the retroreflective film may be structured with diffraction gratings such that the light is reflected by diffraction. For example, lower structured surface 167 of retroreflective film 165 shown in FIG. 1c may have a relief pattern of diffraction grating features arranged to provide a holographic image.

The retroreflective film may have opposing major surfaces that are substantially unstructured, structured with a plurality of features, or a combination thereof. In FIGS. 1a and 1b, both major surfaces 141 and 142 of retroreflective film 140 are structured with a plurality of features, and in FIG. 1c, lower structured surface 167 of retroreflective film 165 is structured, and upper structured surface 166 at interface 168 is not. A surface of the retroreflective film may comprise any one of the plurality of features described above for the viscoelastic lightguide.

Light extracted from the viscoelastic lightguide may or may not be transmitted into the retroreflective film. In some embodiments, the retroreflective film comprises a transparent material into which at least some of the extracted light is transmitted. In some embodiments, the retroreflective film comprises a metal such that the extracted light is not actually extracted; rather the light strikes the interface between the lightguide and the metallic retroreflective film.

In some embodiments, the retroreflective film comprises a holographic film. The holographic film may be a layer of a light transmissive thermoplastic polymer wherein a lower surface of the layer has been embossed to form a plurality of features or relief pattern arranged to provide a holographic image. For example, lower structured surface 167 of retroreflective film 165 as shown in FIG. 1c may be an embossed surface having a relief pattern for providing a holographic image. The relief pattern may be coated with a reflective layer such as a transparent or nontransparent metal. In the front lit configuration, light from the viscoelastic layer is transmitted through the embossed layer and retroreflected by the reflective layer.

The retroreflective film may comprise retroreflective sheeting sometimes referred to as prismatic sheeting. FIG. 2 shows a schematic cross section of exemplary optical device 200 having a front lit configuration. Retroreflective sheeting 240 comprises body layer 241 on which cube corner film 242 is disposed. Cube corner film 242 comprises a plurality of cube cornered features with each feature formed by three converging faces. The features may be truncated cube cornered features. The features typically have a height of from about 20 to about 500 um. Sealing film 243 is adhered to portions of the body layer such that cells, for example, hexagonally shaped cells, of cube corner elements are formed. The sealing film maintains an air interface with the cube corner elements such that retroreflectivity is enhanced. This type of sheeting is employed in many traffic safety and personal safety articles such as road signs, barricades, license plates, pavement markers and marking tape, as well as retroreflective tapes for vehicles and clothing. Exemplary retroreflective sheeting is described in U.S. Provisional Application No. 61/107586 filed on October 22, 2008 (64846US002, Smith et al.); U.S. 2007/0242356 A1 (Thakkar et al.); U.S. 6,280,822 B1 (Smith et al.); U.S. 5,450,235 (Smith et al.), and U.S. 5,784,197 (Frey et al.); all of which are incorporated herein by reference. Exemplary

retroreflective sheeting is available as 3M™ Diamond Grade™ Reflective Sheeting and 3M™ Diamond Grade™ Fluorescent Reflective Sheeting, both from 3M™ Company.

The body layer may comprise a light transmissive layer such as a light transmissive polymeric film, the cube corner elements may comprise a structured reflective film such as a structured polymeric film with a metal coating, and the sealing film may comprise a polymeric material typically comprising particles such as metal oxide particles.

Variations of the embodiment shown in FIG. 2 may be employed. For example, the retroreflective film may comprise cube corner film 242 disposed on body layer 241 without sealing film 243. For another example, the retroreflective film may comprise a cube corner film without the body layer and/or the sealing layer.

In general, the retroreflective film is dimensionally stable, durable, weatherable and flexible so that it can be formed into a desired three dimensional shape.

The thickness of the retroreflective film is not particularly limited as long as it can function as desired. Exemplary thicknesses for the retroreflective film range from about 0.4 mil to about 1000 mil, from about 1 mil to about 300 mil, from about 1 mil to about 60 mil, or from about 0.5 mil to about 30 mil.

The retroreflective film, i.e., the sealing film, may have a refractive index of from about 1.45 to about 1.65. Materials include plastics such as PLEXIGLAS from Rohm and Haas Co., and polymers of alkylene oxides, vinyl ethers, (meth)acrylates such as polymethylmethacrylate and ethylene/acrylic acids, celluloses, cellulose acetates such as cellulose acetate butyrate and ethylene/vinyl acetates, as well as polyolefins, polyesters, polyurethanes, polycarbonates, epoxies, polyvinylalcohols, natural and synthetic rubbers, polyacetals, polyacrylonitriles, polycaprolactams, aromatic polysiloxanes, polystyrenes, polyvinylchlorides and nylons. The retroreflective film may comprise colorants such as particles, dyes or pigments, UV stabilizers and the like.

Given a particular combination of viscoelastic lightguide and retroreflective film, the amount of light retroreflected may be greater than about 10%, greater than about 20%, greater than about 30%, greater than about 40%, greater than about 50%, greater than about 60%, greater than about 70%, greater than about 80%, or greater than about 90% relative to the total amount of light that enters the lightguide. Given a particular

combination of viscoelastic lightguide and retroreflective film, the amount of light retroreflected may be from about 10 to about 50%, from about 20 to about 50%, from about 30 to about 50%, from about 50 to about 70%, from about 50 to about 80%, or from about 10 to about 90% relative to the total amount of light that enters the lightguide.

5           The optical articles of the optical devices described herein can be used in a variety of multilayer constructions depending on the particular application. FIG. 3a shows a schematic cross section of exemplary optical device 300 which includes optical article 301 and light source 105. In this front lit configuration, viscoelastic lightguide 110 is closer to the viewer as indicated by eye 120. Light source 105 is positioned relative to viscoelastic  
10 lightguide 110 such that light emitted by the light source enters viscoelastic lightguide 110 and is transported within the layer by total internal reflection. Optical article 301 comprises retroreflective sheeting 240. In general, any retroreflective film described herein can be used in place of retroreflective sheeting 240, for example, retroreflective film 140 can be used. Optical article 301 comprises first optional layer 305.

15           The first optional layer may be designed to interfere or not interfere with the behavior of light being extracted from the viscoelastic lightguide and/or retroreflected by the retroreflective film. The first optional layer may have opposing major surfaces that are substantially unstructured, structured with a plurality of features, or a combination thereof.

20           The thickness of the first optional layer is not limited as long as the optical device can function as desired. Exemplary thicknesses for the first optional layer range from about 0.4 mil to about 1000 mil.

25           The first optional layer may have a variety of light transmittance and haze properties. In some embodiments, the first optional layer comprises an optically clear substrate having high light transmittance of from about 80 to about 100%, from about 90 to about 100%, from about 95 to about 100%, or from about 98 to about 100% over at least a portion of the visible light spectrum. In some embodiments, the first optional layer has low light transmittance, for example, from about 0.1 to about 70%, from about 0.1 to about 50%, or from about 0.1 to about 20%. In some embodiments, the first optional layer has a haze value of from about 0.01 to less than about 5%, from about 0.01 to less than  
30 about 3%, or from about 0.01 to less than about 1%. In some embodiments, the first optional layer is hazy and diffuses light, particularly visible light. A hazy first optional



layer may have a haze value of from about 5 to about 90%, from about 5 to about 50%, or from about 20 to about 50%. In some embodiments, the first optional layer is translucent in that it reflects and transmits light.

In some embodiments, the first optional layer comprises a polymeric film. Useful  
5 polymeric films include cellulose acetate, poly(meth)acrylate (acrylate and/or methacrylate), polyether sulfone, polyurethane, polyester, polycarbonate, polymethyl methacrylate, polyvinyl chloride, syndiotactic polystyrene, cyclic olefin copolymer, polyethylene terephthalate, polyethylene naphthalate, copolymer or blend based on naphthalene dicarboxylic acids, or some combination thereof. In some embodiments, the  
10 first optional layer comprises a poly(meth)acrylate having a refractive index greater than that of the viscoelastic lightguide.

The first optional layer may comprise glass which generally comprises a hard, brittle, amorphous solid, including, soda-lime glass, borosilicate glass, acrylic glass, sugar glass, and the like.

FIG. 3b shows a schematic cross section of exemplary optical device 320 which  
15 includes optical article 321 and light source 105. In this front lit configuration, viscoelastic lightguide 110 is closer to the viewer as indicated by eye 120. Light source 105 is positioned relative to viscoelastic lightguide 110 such that light emitted by the light source enters viscoelastic lightguide 110 and is transported within the layer by total  
20 internal reflection. Optical article 321 comprises retroreflective sheeting 240. In general, any retroreflective film described herein can be used in place of retroreflective sheeting 240, for example, retroreflective film 140 can be used. Optical article 301 comprises second optional layer 325 and third optional layer 330.

The second optional layer may be designed to interfere or not interfere with the  
25 behavior of light being extracted from the viscoelastic lightguide and/or retroreflected by the retroreflective film. The second optional layer may have opposing major surfaces 326 and 327 that are substantially unstructured, structured with a plurality of features, or a combination thereof. A surface of the second optional layer may comprise any one of the plurality of features described above for the viscoelastic lightguide. For example, major  
30 surface 326 may have features comprising lenses (as shown for surface 176 in FIG. 1d) which are particularly useful for directing light to a preferred angular distribution.

The thickness of the second optional layer is not limited as long as the optical device can function as desired. Exemplary thicknesses for the second optional layer range from about 0.4 mil to about 1000 mil.

5 The second optional layer may have a variety of light transmittance and haze properties. In some embodiments, the second optional layer comprises an optically clear substrate having high light transmittance of from about 80 to about 100%, from about 90 to about 100%, from about 95 to about 100%, or from about 98 to about 100% over at least a portion of the visible light spectrum. In some embodiments, the second optional layer has low light transmittance, for example, from about 0.1 to about 70%, from about 10 0.1 to about 50%, or from about 0.1 to about 20%. In some embodiments, the second optional layer has a haze value of from about 0.01 to less than about 5%, from about 0.01 to less than about 3%, or from about 0.01 to less than about 1%. In some embodiments, the second optional layer is hazy and diffuses light, particularly visible light. A hazy second optional layer may have a haze value of from about 5 to about 90%, from about 5 15 to about 50%, or from about 20 to about 50%. In some embodiments, the second optional layer is translucent in that it reflects and transmits light.

In some embodiments, the second optional layer comprises a polymeric film. Useful polymeric films include cellulose acetate, poly(meth)acrylate (acrylate and/or 20 methacrylate), polyether sulfone, polyurethane, polyester, polycarbonate, polymethyl methacrylate, polyvinyl chloride, syndiotactic polystyrene, cyclic olefin copolymer, polyethylene terephthalate, polyethylene naphthalate, copolymer or blend based on naphthalene dicarboxylic acids, or some combination thereof. In some embodiments, the second optional layer comprises a poly(meth)acrylate having a refractive index greater than that of the viscoelastic lightguide.

25 The second optional layer may comprise glass which generally comprises a hard, brittle, amorphous solid, including, soda-lime glass, borosilicate glass, acrylic glass, sugar glass, and the like.

The second optional layer may comprise a release liner. Release liners typically have a low adhesion surface for contact with an adhesive layer. Release liners may 30 comprise paper such as Kraft paper, or polymeric films such as poly(vinyl chloride), polyester, polyolefin, cellulose acetate, ethylene vinyl acetate, polyurethane, and the like.

The release liner may be coated with a layer of a release agent such as a silicone-containing material or a fluorocarbon-containing material. The release liner may comprise paper or a polymeric film coated with polyethylene which is coated with a silicone-containing material. Exemplary release liners include liners commercially available from  
5 CP Films Inc. under the trade designations "T-30" and "T-10" that have a silicone release coating on polyethylene terephthalate film.

Exemplary release liners include structured release liners. Exemplary release liners include any of those referred to as microstructured release liners. Microstructured release liners are used to impart a microstructure on the surface of an adhesive layer. The  
10 microstructured surface can aid air egress between the adhesive layer and the adjacent layer. In general, it is desirable that the microstructure disappear over time to prevent interference with optical properties. Microstructures are generally three-dimensional structures that are microscopic in at least two dimensions (i.e., the topical and/or cross-sectional view is microscopic). The term "microscopic" as used herein refers to  
15 dimensions that are difficult to resolve by the human eye without aid of a microscope.

The microstructures may assume a variety of shapes. Representative examples include hemispheres, prisms (such as square prisms, rectangular prisms, cylindrical prisms and other similar polygonal features), pyramids, ellipses, grooves (e.g., V-grooves), channels, and the like. In some cases, it may be desirable to include topographical  
20 features that promote air egress at the bonding interface when the article is laminated to a substrate. In this regard, V-grooves and channels that can extend to the edge of the article are particularly useful. The particular dimensions and patterns characterizing the microstructures are selected based upon the specific application for which the article is intended. Another example of useful microstructures are described in US 2007/0292650  
25 A1 (Suzuki) wherein the microstructured adhesive layer surface has one or more grooves that exist only in an inner area of the surface and are not open at side surfaces of the layer. These grooves may be in the form of a straight line, branched straight lines, cross, circle, oval, or polygon as viewed from above, and where each form may be composed of plural discontinuous grooves. These grooves may have a width of from 5 to 100 micrometers  
30 and a depth of from 5 to 50 micrometers.

In some embodiments, the second optional layer may be used to provide an image. A variety of different constructions of the viscoelastic lightguide and the second optional layer may be made to provide an image. The second optional layer may comprise an image printed on either side of the layer, or the image may be embedded in the layer. The image may comprise one or more materials different from that of the second optional layer; the one or more materials may be in regions of the layer wherein the regions are arranged to provide the image. The regions are designed to reflect light or transmit light within a particular range of wavelengths depending on the particular imaging materials.

Imaging materials may be deposited by printing or marking, e.g., by inkjet printing, laser printing, electrostatic printing and the like. Images may be monochrome such as black and white images, or they may be colored images. Images may comprise one or more colors throughout, e.g., a uniform layer of color. Images that provide a general or custom surface may be used. For example, an image may be designed such that the optical article appears as plastic, metal or wood grain; fabric, leather, non-woven, etc. The image may also comprise white dots which may be disposed on a surface or interface. The white dots may be arranged as described for extraction features of conventional solid lightguides, e.g., as described in US 2008/232135 A1 (Kinder et al.). Useful imaging materials include those that reflect all or some light within a particular range of wavelengths. Useful imaging materials include those that transmit all or some light within a particular range of wavelengths. Exemplary imaging materials include colorants such as pigments and dyes. Imaging materials may also comprise photonic crystals.

The third optional layer may be a reflector that reflects light being retroreflected by the retroreflective film. In some embodiments, the reflector comprises a specular reflector wherein the reflection angle of light is within about  $16^\circ$  of the incident angle. A specular reflector may be fully or near fully specular as a reflector over some range of incident angles. Also, specular reflectors may be from about 85 to about 100% reflective, from about 90 to about 100%, or from about 95 to about 100%, across a particular region of the electromagnetic spectrum, for example, the visible region. Suitable specular reflectors include mirrors such as a plane mirrors comprising a film of reflecting material, typically a metal, coated on glass.

In some embodiments, the reflector comprises a diffuse reflector wherein light incident upon the reflector is reflected and scattered at a surface of the diffuse reflector. For a diffuse reflector, light of a given incident angle reflects with multiple reflection angles wherein at least some of the reflection angles are greater than about 16° of the incident angle. A diffuse reflector may be fully or near fully reflective over some range of incident angles. Also, diffuse reflectors may be from about 85 to about 100% reflective, from about 90 to about 100%, or from about 95 to about 100%, across a particular region of the electromagnetic spectrum, for example, the visible region. The diffuse reflector may comprise a layer of organic, inorganic or hybrid organic/inorganic particles disposed on a substrate. The particles may be dispersed in a polymeric material or binder. For example, the diffuse reflector may comprise a layer of barium sulfate particles loaded in a polyethylene terephthalate film.

The third optional layer may comprise a multilayer optical film having from about 10 to about 10,000 alternating layers of first and second polymer layers wherein the polymer layers comprise polyesters. The multilayer optical film may comprise a three-quarter mirror. The multilayer optical film may comprise a mirror. The multilayer optical film may comprise a reflective film, a polarizer film, a reflective polarizer film, a diffuse blend reflective polarizer film, a diffuser film, a brightness enhancing film or a turning film. Exemplary multilayer optical films are described in U.S. 5,825,543; 5,828,488 (Ouderkirk et al.); 5,867,316; 5,882,774; 6,179,948 B1 (Merrill et al.); 6,352,761 B1; 6,368,699 B1; 6,927,900 B2; 6,827,886 (Neavin et al.); 6,972,813 B1 (Toyooka); 6,991,695; 2006/0084780 A1 (Hebrink et al.); 2006/0216524 A1; 2006/0226561 A1 (Merrill et al.); 2007/0047080 A1 (Stover et al.); WO 95/17303; WO 95/17691; WO 95/17692; WO 95/17699; WO 96/19347; WO 97/01440; WO 99/36248; and WO 99/36262. Exemplary specular reflectors include those available from 3M™ Company, for example, 3M™ High Intensity Grade Reflective Products such as High Reflective Visible Mirror Film and High Transmission Mirror Film, and Vikuiti™ films such as Vikuiti™ Enhanced Specular Reflector.

The third optional layer may comprise aluminum.

The third optional layer may comprise a nanofoam which typically comprises a nanostructured, porous material containing pores with diameters of less than about 100

nm. For example, the third optional layer may comprise an aerogel which is a low-density solid state material derived from gel in which the liquid component of the gel has been replaced with air. Silica, alumina and carbon aerogels are exemplary aerogels that may be used. The third optional layer may comprise a low refractive index material such as a  
5 polymer film filled with white particles.

### *Back Lit Configuration*

FIG. 4a shows a schematic cross section of exemplary optical device 400. This embodiment is an example of a back lit configuration in which viscoelastic lightguide 110  
10 is behind retroreflective film 140 or farther than the retroreflective film to the viewer as indicated by eye 120. Exemplary optical device 400 further comprises retroreflective film 140 having upper structured surface 141 and lower structured surface 142. Light propagating within the viscoelastic lightguide may be extracted, as shown by ray 405,  
5 from the lightguide and transmitted through retroreflective film 140.

15 In the back lit configuration, the viscoelastic lightguide may not be in direct contact with the retroreflective film. One or more layers may be disposed between the viscoelastic lightguide and the retroreflective film depending on the desired effect. Embodiments in which the viscoelastic lightguide and the retroreflective film are not in  
20 contact are described below.

In the back lit configuration, the viscoelastic lightguide may be in direct contact with the retroreflective film. FIG. 4b shows a schematic cross section of exemplary  
25 optical device 410 having a back lit configuration. In this embodiment, viscoelastic lightguide 110 is in direct contact with retroreflective film 240, particularly with sealing film 243 of the retroreflective film.

30 In the back lit configuration, the viscoelastic lightguide may have opposing major surfaces that are substantially unstructured, structured with a plurality of features, or one major surface may be substantially unstructured and the other structured with a plurality of features. A structured surface of the viscoelastic lightguide used in the back lit configuration may comprise any of the structured surfaces described above for the front lit  
35 configuration, i.e., a structured surface of the viscoelastic lightguide used in the back lit configuration may comprise a plurality of features, the features having shapes, sizes,

combinations of shapes and sizes, surface structures, etc. as described above for the viscoelastic lightguide used in the front lit configuration. Further, the number and arrangement of features for a structured surface of a viscoelastic lightguide in the back lit configuration may be the same as those described above for the front lit configuration. As described above for the front lit configuration, the shapes and/or sizes of the features may change the amount and/or distribution of light that is extracted from the viscoelastic layer.

As described above for the front lit configuration, the viscoelastic lightguide used in the back lit configuration is generally in contact with at least one medium such as air or a substrate such as the retroreflective film, polymeric film, metal, glass, and/or fabric.

Particular substrates are described below for a variety of exemplary constructions. For the purpose of convenience, a viscoelastic lightguide in contact with a substrate is described below, but this substrate may comprise any type of medium including air. Given a particular retroreflective film or substrate in contact with the viscoelastic lightguide, the amount of light extracted from the lightguide and by the substrate may be from about 10 to about 50%, from about 20 to about 50%, from about 30 to about 50%, from about 50 to about 70%, from about 50 to about 80%, or from about 10 to about 90% relative to the total amount of light that enters the lightguide. The transmittance angle for light extracted from the viscoelastic lightguide by the retroreflective film or substrate may be from greater than about 5° to less than about 95°, greater than about 5° to less than about 60°, or greater than about 5° to less than about 30°.

In the back lit configuration, the viscoelastic lightguide may have a refractive index greater than that of the retroreflective film or the substrate. The refractive index of the viscoelastic lightguide may be greater than about 0.002, greater than about 0.005, greater than about 0.01, greater than about 0.02, greater than about 0.03, greater than about 0.04, greater than about 0.05, greater than about 0.1, greater than about 0.2, greater than about 0.3, greater than about 0.4, or greater than about 0.5, as compared to the refractive index of the retroreflective film or substrate. The viscoelastic lightguide may have a refractive index less than that of the retroreflective film or substrate. The refractive index of the viscoelastic lightguide may be less than about 0.002, less than about 0.005, less than about 0.01, less than about 0.02, less than about 0.03, less than about 0.04, less than about 0.05, less than about 0.1, less than about 0.2, less than about 0.3, less than

about 0.4, or less than about 0.5, as compared to the refractive index of the retroreflective film or substrate. The viscoelastic lightguide and the retroreflective film or substrate may have the same or nearly the same refractive index such that light can be extracted into the retroreflective film or substrate with little or no change to the light. The refractive index difference of the viscoelastic lightguide and the retroreflective film or substrate may be from about 0.001 to less than about 0.002. The refractive index difference of the viscoelastic lightguide and the retroreflective film or substrate may be from about 0.002 to about 0.5, from about 0.005 to about 0.5, from about 0.01 to about 0.5, from about 0.02 to about 0.5, from about 0.03 to about 0.5, from about 0.04 to about 0.5, from about 0.05 to about 0.5, from about 0.1 to about 0.5, from about 0.2 to about 0.5, from about 0.3 to about 0.5, or from about 0.4 to about 0.5.

In the back lit configuration, the viscoelastic lightguide may have any bulk three-dimensional shape as is needed for a given application. The viscoelastic lightguide may be in the form of a square or rectangular layer, sheet, film, etc. The viscoelastic lightguide may be cut or divided into shapes as described below.

In the back lit configuration, the thickness of the viscoelastic lightguide is not particularly limited as long as it can function as desired. As described above for the front lit configuration, the thickness of the viscoelastic lightguide used in the back lit configuration may be selected based on or in conjunction with the light source.

Exemplary thicknesses for the viscoelastic lightguide in the back lit configuration range from about 0.4 mil to about 1000 mil, from about 1 mil to about 300 mil, from about 1 mil to about 60 mil, or from about 0.5 mil to about 30 mil.

As described above for the front lit configuration, the amount and direction of light extracted from the viscoelastic lightguide in the back lit configuration may be controlled, at the very least, by the shape, size, number, arrangement, etc. of the features, the refractive indices of the viscoelastic lightguide and any medium with which the lightguide is in contact, the shape and size of the viscoelastic lightguide, and the angular distribution of light that is allowed to enter the viscoelastic lightguide. These variables may be selected such that from about 10 to about 50%, from about 20 to about 50%, from about 30 to about 50%, from about 50 to about 70%, from about 50 to about 80%, or from about



10 to about 90% of light is extracted from the viscoelastic lightguide relative to the total amount of light that enters the lightguide.

5 The viscoelastic lightguide used in the back lit configuration comprises one or more viscoelastic materials. Useful viscoelastic materials are described above for the viscoelastic lightguide used in the front lit configuration. The viscoelastic lightguide used in the back lit configuration can optionally include one or more additives as described above.

Retroreflective films described above for the front lit configuration are suitable for use in the back lit configuration.

10 In the back lit configuration, given a particular combination of viscoelastic lightguide and retroreflective film, the amount of light transmitted through the retroreflective film may be greater than about 10%, greater than about 20%, greater than about 30%, greater than about 40%, greater than about 50%, greater than about 60%, greater than about 70%, greater than about 80%, or greater than about 90% relative to the total amount of light that enters the lightguide. Given a particular combination of  
15 viscoelastic lightguide and retroreflective film, the amount of light transmitted through the retroreflective film may be from about 10 to about 50%, from about 20 to about 50%, from about 30 to about 50%, from about 50 to about 70%, from about 50 to about 80%, or from about 10 to about 90% relative to the total amount of light that enters the lightguide.

20 In general, the viscoelastic lightguide used in the back lit configuration is adapted to receive at least some light emitted by the light source. In some embodiments, a specially designed input surface may not be needed because the light source can be pressed into the viscoelastic lightguide such that optical coupling occurs. In some embodiments, the light source may stick to the viscoelastic lightguide, for example, if the  
25 lightguide comprises a PSA. In some embodiments, the light source may be embedded in the viscoelastic lightguide. As described above for the front lit configuration, the viscoelastic lightguide may comprise an input surface adapted to receive light from the light source, or an extractor article or coupling material may be used to facilitate optical coupling with at least some of the light emitted by the light source.

30 In the back lit configuration, the light source and the means by which it is powered may be the same as those described above for the front lit configuration.

The optical articles of the optical devices described herein can be used in a variety of multilayer constructions depending on the particular application. FIG. 5 shows a schematic cross section of exemplary optical device 500 which includes optical article 501 and light source 105. In this back lit configuration, viscoelastic lightguide 110 is farther from the viewer as indicated by eye 120. Light source 105 is positioned relative to viscoelastic lightguide 110 such that light emitted by the light source enters viscoelastic lightguide 110 and is transported within the layer by total internal reflection. Optical article 501 comprises retroreflective sheeting 240. In general, any retroreflective film described herein can be used in place of retroreflective sheeting 240, for example, retroreflective film 140 can be used. Optical article 501 comprises first optional layer 505, second optional layer 510 and third optional layer 515.

In the back lit configuration, the first and/or second optional layers may be designed to interfere or not interfere with the behavior of light being extracted from the viscoelastic lightguide and/or transmitted through the retroreflective film. The first and/or second optional layers may have opposing major surfaces that are substantially unstructured, structured with a plurality of features, or a combination thereof. For example, major surface 511 may have features comprising lenses (as shown for surface 176 in FIG. 1d) which are particularly useful for directing light to a preferred angular distribution.

The thicknesses of the first and/or second optional layer are not limited as long as the optical device can function as desired. Exemplary thicknesses for the first and/or second optional layers range from about 0.4 mil to about 1000 mil.

The first and/or second optional layers may have a variety of light transmittance and haze properties. In some embodiments, the first optional layer comprises an optically clear substrate having high light transmittance of from about 80 to about 100%, from about 90 to about 100%, from about 95 to about 100%, or from about 98 to about 100% over at least a portion of the visible light spectrum. In some embodiments, the first optional layer has low light transmittance, for example, from about 0.1 to about 70%, from about 0.1 to about 50%, or from about 0.1 to about 20%. In some embodiments, the first optional layer has a haze value of from about 0.01 to less than about 5%, from about 0.01 to less than about 3%, or from about 0.01 to less than about 1%. In some embodiments,

the first optional layer is hazy and diffuses light, particularly visible light. A hazy first optional layer may have a haze value of from about 5 to about 90%, from about 5 to about 50%, or from about 20 to about 50%. In some embodiments, the first optional layer is translucent in that it reflects and transmits light.

5           In some embodiments, the first and/or second optional layer comprises a polymeric film. Useful polymeric films include cellulose acetate, poly(meth)acrylate (acrylate and/or methacrylate), polyether sulfone, polyurethane, polyester, polycarbonate, polymethyl methacrylate, polyvinyl chloride, syndiotactic polystyrene, cyclic olefin copolymer, polyethylene terephthalate, polyethylene naphthalate, copolymer or blend based on  
10 naphthalene dicarboxylic acids, or some combination thereof. In some embodiments, the first optional layer comprises a poly(meth)acrylate having a refractive index greater than that of the viscoelastic lightguide.

          The first and/or second optional layer may comprise glass which generally comprises a hard, brittle, amorphous solid, including, soda-lime glass, borosilicate glass,  
15 acrylic glass, sugar glass, and the like.

          The second optional layer may comprise a release liner as described above.

          In some embodiments, the second optional layer may be used to provide an image as described above. In some embodiments, the second optional layer may be an adhesive. Useful adhesives include optically clear adhesives, optically diffuse adhesives, radiation  
20 cured adhesives, thermal cured adhesives, hot melt adhesives, cold seal adhesives, heat activated adhesives, adhesives that cure at room temperature.

          In the back lit configuration, the third optional layer may be a reflector that reflects light being transported within the viscoelastic lightguide. Useful reflectors comprise specular and diffuse reflectors. The third optional layer may comprise a multilayer optical  
25 film.

          The third optional layer may comprise a nanofoam which typically comprises a nanostructured, porous material containing pores with diameters of less than about 100 nm. For example, the third optional layer may comprise an aerogel which is a low-density solid state material derived from gel in which the liquid component of the gel has been  
30 replaced with air. Silica, alumina and carbon aerogels are exemplary aerogels that may be

used. The third optional layer may comprise a low refractive index material such as a polymer film filled with white particles.

#### *Front and Back Lit Configurations*

5 In both front and back configurations, the viscoelastic lightguide is adapted to receive at least some light emitted by the light source. In some embodiments, a specially designed input surface may not be needed because the light source can be pressed into the viscoelastic lightguide such that optical coupling occurs. In some embodiments, the light source may stick to the viscoelastic lightguide, for example, if the lightguide comprises a PSA. In some embodiments, the light source may be embedded in the viscoelastic  
10 lightguide.

In some embodiments, the viscoelastic lightguide comprises an input surface adapted to receive light from the light source. The input surface may have a variety of topographies depending on the optical coupling means and/or the particular light source. The input surface may have an appropriate curvature. The input edge comprising the  
15 input surface may have a particular cavity, for example a concave hemispherical cavity, to receive a convex lens of a light source. Alternately, the input surface may have refractive structures such as prisms or lenses to optically couple light from the light source into the viscoelastic lightguide.

In some embodiments, an extractor article disposed between the light source and  
20 the input edge may be used to facilitate optical coupling with at least some of the light emitted by the light source. Useful extractor articles may have an appropriate curvature for extracting light from the light source. A coupling material for matching refractive indices of the viscoelastic lightguide and some element of the light source may be used. A crosslinkable material may be used for attaching the viscoelastic lightguide to some part of  
25 the light source, and subsequently cured using heat and/or light to form the crosslinked material.

The coupling material may comprise silicone gel. The silicone gel may be crosslinked. The silicone gel may be mixed with a silicone oil. The silicone gel may comprise one or more silicone materials such as, for example, dimethylsilicone,  
30 diphenylsilicone, or phenylmethylsilicone. The silicone gel may comprise phenylmethylsilicone moieties that are cross-linked. The silicone gel may comprise

phenylmethylsilicone moieties which are cross-linked and phenylmethylsilicone oil. The silicone gel may comprise phenylmethylsilicone moieties which are cross-linked and phenylmethylsilicone oil in a weight ratio from 0.2:1 to 5:1. The silicone gel may comprise crosslinked phenylmethylsilicone. Exemplary use of silicone gels is described  
5 in U.S. 7,315,418 (DiZio et al.) incorporated herein by reference.

In both front and back configurations, the light source may be optically coupled to the viscoelastic lightguide such that at least some of the light from the light source can enter the lightguide. For example, a light source may be optically coupled to the viscoelastic lightguide such that from about 1 to about 10%, from about 1 to about 20%,  
10 from about 1 to about 30%, from about 1 to about 40%, from about 1 to about 50%, from about 1 to about 100%, from about 1 to about 100%, from about 50 to about 100%, or from about 1 to about 100% of light emitted by the light source enters the viscoelastic lightguide. The light source may emit light having a random or a particular angular distribution.

The light source may comprise any suitable light source. Exemplary light sources  
15 include linear light sources such as cold cathode fluorescent lamps and point light sources such as light emitting diode (LEDs). Exemplary light sources also include organic light-emitting devices (OLEDs), incandescent bulbs, fluorescent bulbs, halogen lamps, UV bulbs, infrared sources, near-infrared sources, lasers, or chemical light sources. In  
20 general, the light emitted by the light source may be visible or invisible. At least one light source may be used. For example, from 1 to about 10,000 light sources may be used. The light source may comprise a row of LEDs positioned at or near an edge of the viscoelastic lightguide. The light source may comprise LEDs arranged on a circuit such that light emitted from the LEDs lights up continuously or uniformly the viscoelastic lightguide  
25 throughout a desired area. The light source may comprise LEDs that emit light of different colors such that the colors can mix within the viscoelastic lightguide. In this way, a graphic could be designed to appear differently at different times during its use.

The light source may be powered by any suitable means. The light source may be powered using a battery, a DC power supply, an AC to DC power supply, an AC power  
30 supply, or a solar photovoltaic cell.

The viscoelastic lightguide may be made using any method or process commonly used for making viscoelastic articles. Typical processes comprise those that are continuous processes such as continuous cast and cure, extrusion, microreplication, and embossing methods. Various types of radiation may be used for processes in which a material needs to be cured, e.g., crosslinked. Conventional molding processes may also be used. Molds may be made by micro-machining and polishing of a mold material to create the desired features, structured surfaces, etc. Laser ablation may be used to structure a surface of the viscoelastic lightguide and molds. Further detailed description of these processes is described in the Sherman et al. references cited above.

Optical articles comprising the viscoelastic lightguide and retroreflective film may be made in a number of ways. In some embodiments, the lightguide and retroreflective film may be made separately, contacted and pressed together using finger pressure, a hand roller, an embosser or a laminator. In some embodiments, the retroreflective film may be formed on the viscoelastic lightguide by coating a retroreflective film material on the lightguide. The retroreflective film material may then be treated to form the retroreflective film. For example, the retroreflective film material may be extruded onto the viscoelastic lightguide in the form of a layer and cooled to solidify the material to form the retroreflective film. Alternatively, the retroreflective film material may be curable and treated by heating and/or applying radiation to form the retroreflective film. The retroreflective film material may include solvent and the retroreflective film is formed by removing the solvent.

In some embodiments, the viscoelastic lightguide may be formed on the retroreflective film by coating a viscoelastic material on the retroreflective film. The viscoelastic material may then be treated to form the viscoelastic lightguide. For example, the viscoelastic material may be extruded onto the retroreflective film in the form of a layer and cooled to solidify the material to form the lightguide. Alternatively, the viscoelastic material may be curable and treated by heating and/or applying radiation to form the lightguide. The viscoelastic material may include solvent and the lightguide is formed by removing the solvent.

In cases where the retroreflective film material or the viscoelastic material is curable, an optical article having a partially cured retroreflective film or lightguide,

respectively, may be made. In cases where the retroreflective film material or the viscoelastic material is curable, chemically curing materials may be used such that the material is crosslinked. In cases where the retroreflective film material or the viscoelastic material is curable, the retroreflective film material may be cured before, after and/or  
5 during contact with another material or the light source.

In cases where the retroreflective film material or the viscoelastic material is curable using light, the light source may be optically coupled to the material and curing carried out by injecting light from the light source.

A retroreflective film may be used to structure a surface of the viscoelastic lightguide, e.g., the viscoelastic lightguide may not be structured by itself, rather, it  
10 becomes structured when contacted with a structured surface of a retroreflective film. It is also possible for the viscoelastic lightguide to have a structured surface such that it deforms a surface of a retroreflective film to create the interface.

The optical articles and optical devices disclosed herein may be provided in any number of ways. The optical articles and optical devices may be provided as sheets or  
15 strips laid flat, or they can be rolled up to form a roll. The optical articles and optical devices may be packaged as single items, or in multiples, in sets, etc. The optical articles and light sources may be provided in an assembled form, i.e., as an optical device. The optical articles and light sources may be provided as kits wherein the two are separate  
20 from each other and assembled at some point by the user. The optical articles and light sources may also be provided separately such that they can be mixed and matched according to the needs of the user. The optical articles and optical devices may be temporarily or permanently assembled to light up.

The optical articles disclosed herein may be altered depending on a particular use.  
25 For example, the optical articles can be cut or divided by any suitable means, e.g., using a scissors or a die cutting method. A particularly useful die cutting method is described in U.S. Provisional Serial No. 61/046813 (64033US002, Sherman et al.) incorporated herein by reference. The optical articles and devices may be cut or divided into different shapes such as alphabetic letters; numbers; geometric shapes such as squares, rectangles,  
30 triangles, stars and the like.

The optical articles and optical devices may be used for signage such as for graphic arts applications. The optical articles and optical devices may be used on or in windows, walls, wallpaper, wall hangings, pictures, posters, billboards, pillars, doors, floormats, vehicles, or anywhere signage is used. Exemplary optical articles a may be  
5 used on curved surfaces as shown in FIG. 19 of 61/169973 filed on April 16, 2009 (64347US008, Sherman et al.).

The optical articles and optical devices may be double-sided such that light can be observed on both sides of a sign, marking, etc. FIG. 6 shows a schematic cross section of exemplary optical device 600 comprising optical article 601 and light sources 605 and  
10 606. In this embodiment, light is observable on both sides of the device as shown by eyes 620 and 621. First viscoelastic lightguides 610 and second viscoelastic lightguide 611 are disposed on opposing sides of third optional layer 650. First retroreflective film 640 is disposed on first viscoelastic layer 610 opposite third optional layer 650. Likewise, second retroreflective film 641 is disposed on second viscoelastic layer 611 opposite third  
15 optional layer 650.

Optical article 601 is an example of a double-sided graphic in which graphics on opposing sides of the third optional layer 650 have back lit configurations. In general, optical articles may be designed to be double-sided for a variety of applications. A  
20 double-sided optical article may have two back lit configurations, two front lit configurations or a combination thereof.

The optical articles and devices may be used for safety purposes wherever light is desired. For example, the optical articles and devices may be used to illuminate one or more steps of a ladder, steps of a stairway, aisles such as in airplanes and movie theatres, walkways, egress, handrails, work zone identification signs and markings. An exemplary  
25 optical article for one of these applications is shown in FIG. 20 of 61/169973 filed on April 16, 2009 (64347US008, Sherman et al.).

The optical articles and optical devices may be used in a variety of items such as reading lights; party and holiday decorations such as hats, ornaments, string lighting, balloons, gift bags, greeting cards, wrapping paper; desk and computer accessories such as  
30 desk mats, mousepads, notepad holders, writing instruments; sporting items such as fishing lures; craft items such as knitting needles; personal items such as toothbrushes;



household and office items such as clock faces, wall plates for light switches, hooks, tools. An exemplary optical article for one of these applications is shown in FIG. 21 of 61/169973 filed on April 16, 2009 (64347US008, Sherman et al.).

5 The optical articles and optical devices may be used on clothing and clothing accessories for decorative and/or safety purposes. For example, the optical articles and optical devices may be used on outerwear for cyclists, or on clothing or headgear for miners. For another example, the optical articles and optical devices may be used on or in straps and wristbands of watches, or on or in watch faces. An exemplary optical article for one of these applications is shown in FIG. 22 of 61/169973 filed on April 16, 2009  
10 (64347US008, Sherman et al.).

The optical articles and optical devices may be used anywhere light is needed or desired. The optical articles and optical devices may be disposed on a top surface of a shelf such that light from the article or device, respectively, is emitted in an upward direction. Likewise, the optical articles and optical devices may be disposed on a bottom  
15 surface of a shelf such that light from the article or device, respectively, is emitted in a downward direction. The optical articles and optical devices may also be disposed on or within a shelf having a light transmissive portion. The articles and devices may be arranged such that light is emitted from the light transmissive portion. An exemplary optical article for one of these applications is shown in FIG. 23 of 61/169973 filed on  
20 April 16, 2009 (64347US008, Sherman et al.).

The optical articles and devices may be used as flashlights. For example, optical articles and optical devices may be disposed on the outside or inside of a battery cover plate or other part of an electronic handheld device. The optical articles and optical devices may or may not be hardwired to the electronic device's battery but could have its  
25 own power source. The electronic device's battery cover may or may not be removable from the rest of the device comprising the display.

The optical articles and optical devices may be used for vehicles such as automobiles, marine vehicles, buses, trucks, railcars, trailers, aircraft, and aerospace vehicles. The optical articles and devices may be used on almost any surface of a vehicle  
30 including the exterior, interior, or any in-between surface. For example, the optical articles and devices may be used to light up door handles on the exterior and/or interior of

a vehicle. The optical articles and devices may be used to illuminate trunk compartments, for example, they may be positioned on the underside of the trunk lid or inside the compartment. The optical articles and devices may be used on bumpers, spoilers, floor boards, windows, on or as tail lights, sill plate lights, puddle lights, emergency flashers, center high mounted stop lights, or side lights and markers. The optical articles and devices may be used to illuminate the inside of engine compartments, for example, they may be positioned on the underside of the hood, inside the compartment, or on an engine part.

The optical articles and devices may also be used on the edge surfaces of vehicular doors between the exterior and interior panels of the doors. These optical articles and devices may be used to provide a variety of information for the user, manufacturer, etc. The optical articles and devices may be used to illuminate the instrument panel of a vehicle where lighted areas are typically displayed. The optical articles and devices may be used on other interior items such as cupholders, consoles, handles, seats, doors, dashboards, headrests, steering wheels, wheels, portable lights, compasses, and the like. The optical articles and devices may be used on back or pass areas for reading light or to provide ambient lighting for inside a vehicle. FIG. 24 61/169973 filed on April 16, 2009 (64347US008, Sherman et al.) shows an exemplary automobile having optical articles 2400 and 2401.

The optical articles and optical devices may be used in the manufacture of an item or as a replacement part of an item. For example, the optical articles and optical devices may be sold to an automobile manufacturer or automobile repair shop for assembly or repair of some specific part of an automobile. FIG. 25 of 61/169973 filed on April 16, 2009 (64347US008, Sherman et al.) shows an exemplary automobile having tail light 2500. An optical article or optical device (not shown) is disposed behind the outside layer of the tail light which is typically red, yellow or clear plastic. The tail light may comprise a cavity with a light bulb or LED as a light source. An optical article or device may be used in the cavity as a replacement for the light source. Alternatively, the tail light may not comprise a cavity or at least comprise a much smaller cavity than is used in today's automobiles. An optical article or optical device may be disposed behind or within the outside layer of the tail light such that the overall size of the tail light is reduced.

The optical articles and optical devices may be used for traffic safety such as for traffic signs, street signs, highway dividers and barriers, toll booths, pavement markings, and work zone identification signs and markings. The optical articles and devices may be used on license plates for decoration, to provide information such as vehicle registration, etc. The optical articles and devices may also be used to provide light near license plates such that the license plates are lit up from the side, top, etc.

The optical articles and optical devices may be used with illumination devices comprising hollow light recycling cavities sometimes referred to as backlight assemblies. Backlight assemblies may be used for signage or general lighting. Exemplary backlight assemblies are disclosed in WO 2006/125174 (Hoffman et al.) and US 2008/0074901 (David et al.) all incorporated herein by reference. The optical articles and optical devices disclosed herein may be used to replace the light sources described in these references.

FIG. 7 shows a schematic cross section of an exemplary backlight assembly 700. The backlight assembly comprises housing 705 having a plurality of internal surfaces 706a-c and two opposing side surfaces 707a and b (not shown) substantially parallel to the plane of the cross section. At least one of these internal surfaces 706a-c and 707a and b is reflective. Backlight assembly 700 also comprises light sources 710 positioned along the bottom of the assembly, however, the light sources may also be positioned along any of the other sides of the housing. Backlight assembly 700 also comprises optical article 720. Housing 705 and optical article 720 form an enclosed backlight. Housing 705 may comprise metal and/or polymer. Reflective internal surfaces may comprise any of the reflectors and reflective surfaces described above.

In this embodiment, optical article 720 comprises multilayer optical film 721, viscoelastic lightguide 722 disposed on the multilayer optical film, retroreflective film 723 disposed on the lightguide opposite the multilayer optical film, and additional layer 724 disposed on the retroreflective film opposite the lightguide. The multilayer optical film may comprise a three-quarter mirror as described above. The viscoelastic lightguide 722 and retroreflective film 723 may each comprise any of those described above. Additional layer 724 may comprise any material that transmits light from inside the enclosed backlight to outside illumination device 700. Additional layer 724 may comprise a polymeric film which may be diffusive and/or translucent. Polymeric film 724 may also

provide an image as described above and in 61/169973 filed on April 16, 2009 (64347US008, Sherman et al.).

The optical articles and optical devices may be used on or in display devices such as cell phones, personal digital devices, MP3 players, digital picture frames, monitors, laptop computers, projectors such as mini-projectors, global positioning displays, televisions, etc. The optical articles may be used in place of conventional lightguides used to backlight a display panel of the display device. For example, the viscoelastic lightguide may be used to replace a solid or hollow lightguide that distributes light from one or more substantially linear or point light sources. The display device can be assembled without the need for adhesives to bond display components to the viscoelastic lightguide. Exemplary display devices include those having LCD and plasma display panels. Exemplary display devices are described in 61/169973 filed on April 16, 2009 (64347US008, Sherman et al.); (US 2008/232135 A1 (Kinder et al.) and US 6,111,696 (Allen et al.).

The optical articles and devices may be used for lighting buttons and keypads in various electronic devices including the display devices described above. In this case, the optical articles and devices are used in place of a conventional lightguide as described in FIG. 28 of 61/169973 filed on April 16, 2009 (64347US008, Sherman et al.); U.S. 7,498,535 (Hoyle); U.S. 2007/0279391 A1 (Marttila, et al.), U.S. 2008/0053800 A1 (Hoyle), and U.S. Serial No. 12/199862 (63619US006, Sahlin, et al.) all incorporated herein by reference.

The optical articles and optical devices disclosed herein may be incorporated into security films or laminates. These security laminates are used to protect documents or packages to ensure that underlying items are not altered. Security laminates may be used to make driver licenses, passports, tamper proof seals and the like. Exemplary security film constructions are described in US 5,510,171 (Faykish); US 6,288,842 (Florczak et al.); and US Serial No. 12/257223 (64812US002, Endle et al.) all incorporated herein by reference.

FIG. 8 shows a schematic cross section of an exemplary optical article 800 comprising viscoelastic lightguide 801 and retroreflective film 802. Retroreflective film 802 may comprise a holographic film. A similar construction is shown in FIG. 1 of

Faykish. Adhesive layer 820 is patterned in the form of an image and this layer is disposed between retroreflective film 802 and adhesive layer 825. Adhesive layer 825 is disposed on document 830 which is a document to be protected. Protective layer 840 protects the surface of the viscoelastic lightguide and/or other layers in between the protective layer and the lightguide. Protective layer 840 is typically a polymeric film or glass. Optical article 800 has a front lit configuration and back lit configurations may be used.

The optical articles and optical devices may be used in the construction of an illuminated license plate. Useful optical articles include the front lit and back lit optical articles described in U.S. 2007/0006493 (Eberwein); U.S. 2007/0031641 A1 (Frisch et al.); U.S. 20070209244 (Prollius et al.); WO 2008/076612 A1 (Eberwein); WO 2008/121475 A1 (Frisch); WO 2008/016978 (Wollner et al.) and WO 2007/92152 A2 (Eberwein); all incorporated herein by reference.

FIG. 9 shows a schematic cross section of exemplary license plate assembly 900 having a back lit configuration. A similar assembly is shown in FIG. 6 of Prollius et al. License plate assembly 900 comprises frame 901 onto which is disposed light source 905. Viscoelastic lightguide 910 is adjacent the light source. Retroreflective film 930 is disposed on top of the viscoelastic lightguide relative to the viewer shown as eye 950. Disposed between the retroreflective film 930 and viscoelastic lightguide 910 is some material 940 having a relatively low refractive index as compared to that of retroreflective film 930. Material 940 may comprise air, a polymer or an aerogel as described above. License plate 960 with indicia 961 are adhered to retroreflective film 930 with adhesive layer 970. Viscoelastic lightguide 910 may comprise a PSA. Useful adhesives include optically clear adhesives, optically diffuse adhesives, radiation cured adhesives, thermal cured adhesives, hot melt adhesives, cold seal adhesives, heat activated adhesives, adhesives that cure at room temperature.

Another exemplary license plate assembly comprises indicia disposed on the retroreflective film, thus eliminating the need for license plate 960 and adhesive layer 970. In this case, the retroreflective film is the license plate.

In embodiments comprising retroreflective sheeting, the sheeting may be “flipped over” such that the sealing film is closer than the body layer to the viewer. In a front lit

configuration, viscoelastic lightguide is adjacent the sealing film. A layer of an optically transmissive film such as polymethylmethacrylate (for protection) may be disposed on the opposite side of the viscoelastic lightguide. A reflector such as a specular reflector may be disposed on the retroreflective sheeting opposite the viscoelastic lightguide. In a back lit configuration, viscoelastic lightguide is adjacent the body layer. A reflector such as a specular reflector may be disposed on the retroreflective sheeting opposite the viscoelastic lightguide.

The terms “in contact” and “disposed on” are used generally to describe that two items are adjacent one another such that the whole item can function as desired. This may mean that additional materials can be present between the adjacent items, as long as the item can function as desired.

### Examples

#### Example 1

A 3-layer laminate was prepared from 3 pieces of tape (VHB™ Acrylic Tape 4910F from 3M Company) comprising a clear acrylic PSA having a nominal thickness 1 mm and a refractive index of 1.473 as measured using an Abbe refractometer. A hand roller was used to prepare the 3-layer laminate. This 3-layer laminate was then laminated to the face surface (viewer's side) of 3M™ Diamond Grade™ Reflective Sheeting from 3M™ Company (4" x 8" area) so that the sheeting was front lit. A side-emitting LED was pressed into the core PSA from one end and light was easily passed through the entire 8 inches of the 3-layer laminate and was able to be visibly seen exiting. Light was also extracted perpendicular to the light source along the white hexagon seal pattern of the sheeting.

25

#### Example 2

An adhesive composition formulated with 90/10 isooctyl acrylate/acrylic acid, 0.3 wt% hexanediol diacrylate and 0.2 wt% IRGACURE 651 photoinitiator (Ciba Specialty) was coated onto a 5 mil mirror film (Vikuiti™ Enhanced Specular Reflector from 3M™ Co.) which had 2 ribbons of side-emitting light emitting diodes (LEDs) attached 9 inches apart (with double stick adhesive). The adhesive composition was coated using a notched

30

bar knife coater and covered with a silicone release liner (CP Films T10 2.0 mil polyester release liner). The adhesive composition was cured using a low intensity UV lamp for 15 minutes. The adhesive composition was coated at a wet thickness of 70 mils to completely encapsulate the LED ribbons. The adhesive had a thickness of 40 mils and a refractive index of 1.474 (as measured on an Abbe refractometer). The adhesive was removed from the ribbons at a connection point so that the LEDs could be powered. 3M™ Diamond Grade™ DG3 Reflective Sheeting (Series 4000) was then laminated on top of this LED embedded lightguide construction (9" x 36" area). The encapsulated side emitting LEDs were powered and light was easily passed through the entire 9 inches of PSA length and was able to be visibly seen exiting through the reflective sheeting.

### Example 3

An adhesive composition formulated with 90/10 isooctyl acrylate/acrylic acid, 0.3 wt% hexanediol diacrylate and 0.2 wt% IRGACURE 651 photoinitiator (Ciba Specialty) was coated onto a 5 mil mirror film (Vikuiti™ Enhanced Specular Reflector from 3M™ Co.) which had 2 ribbons of side-emitting light emitting diodes (LEDs) attached 9 inches apart (with double stick adhesive). The adhesive composition was coated using a notched bar knife coater and covered with a silicone release liner (CP Films T10 2.0 mil polyester release liner). The adhesive composition was cured using a low intensity UV lamp for 15 minutes. The adhesive composition was coated at a wet thickness of 70 mils to completely encapsulate the LED ribbons. The adhesive had a thickness of 40 mils and a refractive index of 1.474 (as measured on an Abbe refractometer). The adhesive was removed from the ribbons at a connection point so that the LEDs could be powered. Flexible reflective sheeting comprising 3M™ Diamond Grade™ Reflective Sheeting without the polycarbonate film was then laminated on top of this LED embedded light guide construction (9" x 36" area). The encapsulated side emitting LEDs were powered and light was easily passed through the entire 9 inches of PSA length and was able to be visibly seen exiting through the reflective sheeting.

What is claimed is:

1. An optical device comprising:  
a light source;  
5 a viscoelastic lightguide, wherein light emitted by the light source enters the viscoelastic lightguide and is transported within the lightguide by total internal reflection;  
and  
a retroreflective film suitable for retroreflecting light, wherein light being transported within the viscoelastic lightguide is extracted from the lightguide and  
10 retroreflected from a structured surface of the retroreflective film.
2. The optical device of claim 1, wherein retroreflected comprises reflected by refraction.
- 15 3. The optical device of claim 1, wherein retroreflected comprises reflected by diffraction.
4. An optical device comprising:  
a light source;  
20 a viscoelastic lightguide, wherein light emitted by the light source enters the viscoelastic lightguide and is transported within the lightguide by total internal reflection;  
and  
a retroreflective film suitable for retroreflecting light, wherein light being transported within the viscoelastic lightguide is extracted from the lightguide and  
25 transmitted through the retroreflective film.
5. The optical device of claim 1 or 4, wherein at least about 80% of light being transported within the viscoelastic lightguide is extracted from the lightguide.
- 30 6. The optical device of claim 1 or 4, wherein the viscoelastic lightguide comprises a pressure sensitive adhesive.



7. The optical device of claim 1 or 4, wherein the device is flexible.
8. The optical device of claim 1 or 4, wherein the viscoelastic lightguide has a light  
5 transmittance of from about 90 to about 100% and a haze value of from about 0.01 to less  
than about 5%.
9. The optical device of claim 1 or 4, wherein the retroreflective film has a refractive  
10 index greater than that of the viscoelastic lightguide.
10. The optical device of claim 1 or 4, wherein the viscoelastic lightguide contacts the  
retroreflective film.
11. The optical device of claim 1 or 4, wherein a polymeric film is disposed between  
15 the viscoelastic lightguide and the retroreflective film.
12. The optical device of claim 1 or 4, wherein the retroreflective film comprises  
prismatic retroreflective sheeting.
- 20 13. The optical device of claim 1 or 4, wherein the retroreflective film is disposed on a  
mirror.
14. The optical device of claim 1 or 4, wherein the viscoelastic layer is disposed on a  
printed graphic film.
- 25 15. The optical device of claim 1 or 4, wherein the viscoelastic layer is disposed on a  
holographic film.
16. The optical device of claim 1 or 4, wherein the viscoelastic lightguide is disposed  
30 on a multilayer optical film comprising a three-quarter mirror.

17. The optical device of claim 1 or 4, wherein the retroreflective film comprises retroreflective sheeting, and the viscoelastic lightguide is disposed between the sheeting and a multilayer optical film comprising a three-quarter mirror.
- 5 18. The optical device of claim 1 or 4, wherein a light diffusing layer is disposed between the retroreflective film and the viscoelastic lightguide.
19. The optical device of claim 4, wherein the viscoelastic lightguide is disposed on a mirror.
- 10 20. The optical device of claim 4, wherein the retroreflective film comprises retroreflective sheeting, and the viscoelastic lightguide is disposed between the sheeting and a mirror.
- 15 21. The optical device of claim 1 or 4, wherein the viscoelastic lightguide is disposed on a release liner.
22. A sign or marking comprising the optical device of claim 1 or 4.
- 20 23. A license plate assembly comprising the optical device of claim 1 or 4.
24. A security laminate comprising the optical device of claim 1 or 4.
- 25 25. A tail light assembly suitable for use with a vehicle, the tail light assembly comprising a housing, a transparent cover and the optical device of claim 1 or 4.
26. An illumination device comprising a housing, a light emitting layer and the optical device of claim 1 or 4.

27. The illumination device of claim 26, wherein the illumination device provides uniform illumination having a minimum brightness that is at least about 70% of a maximum brightness.

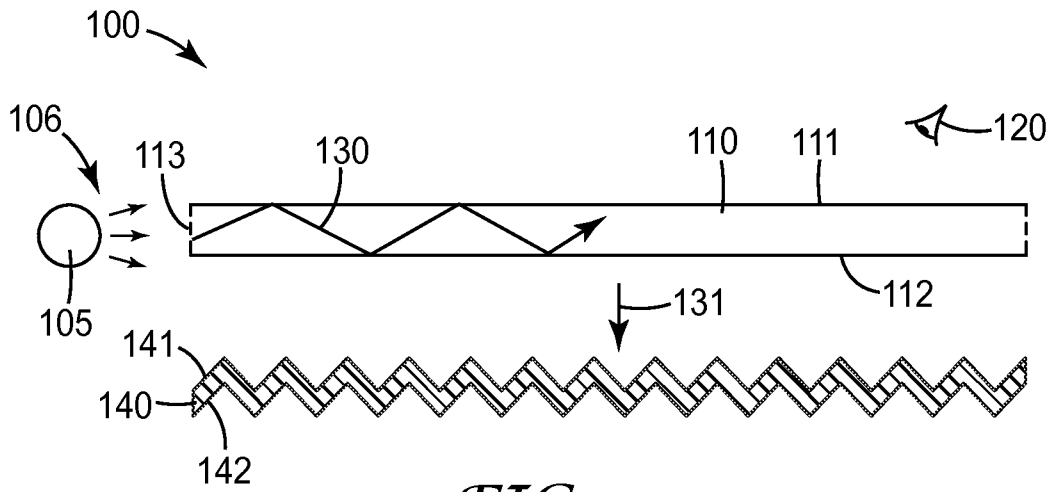

FIG. 1a

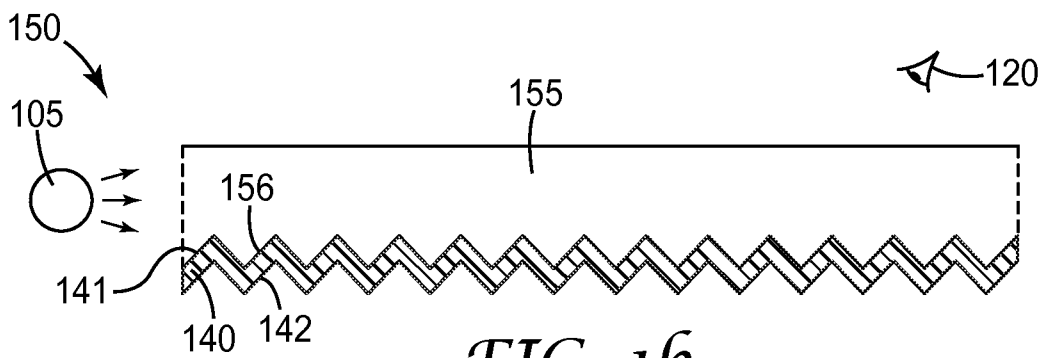

FIG. 1b

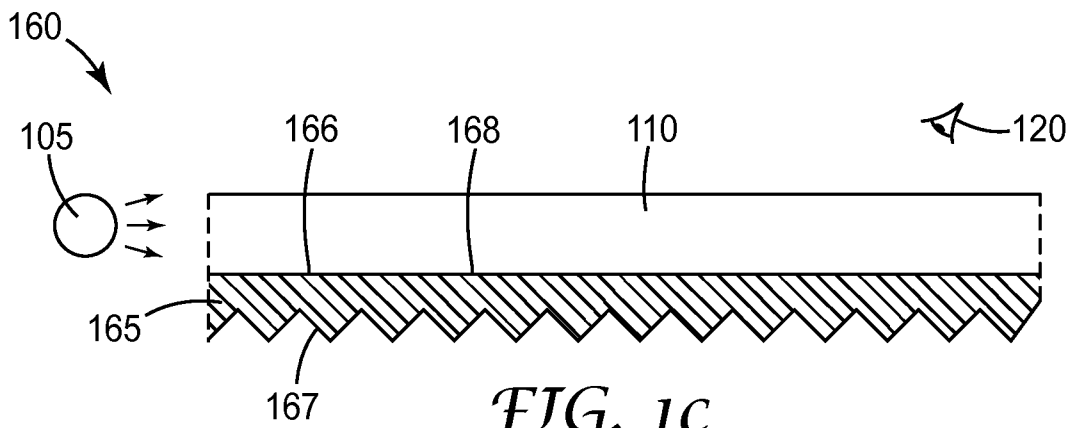

FIG. 1c

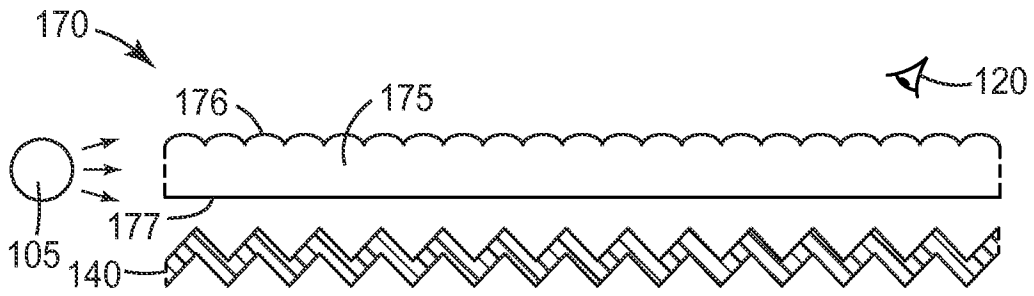

FIG. 1d

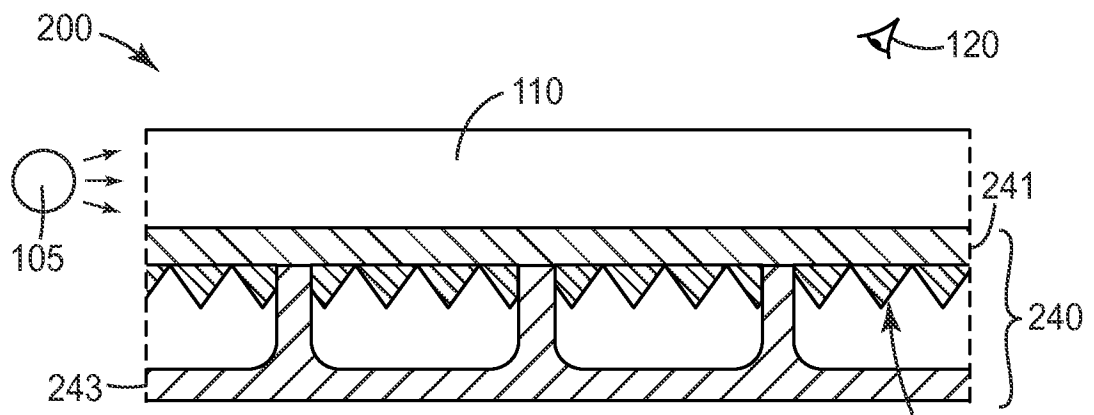

FIG. 2

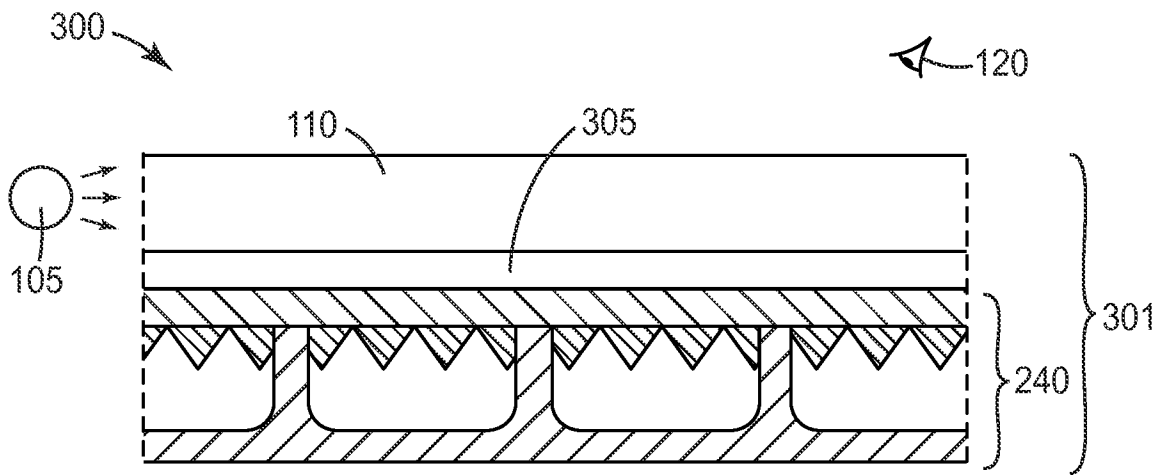

FIG. 3a

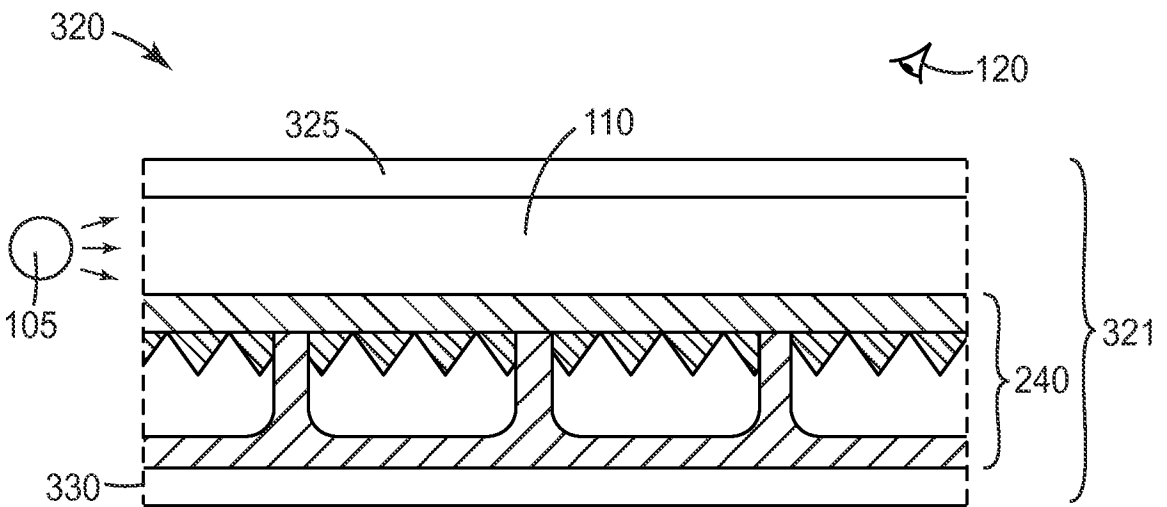

FIG. 3b



FIG. 4a

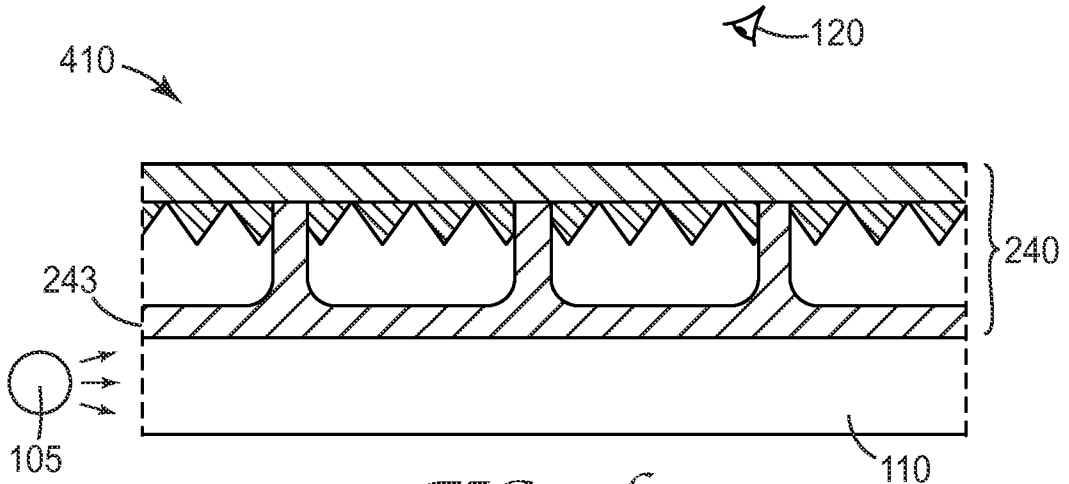

FIG. 4b

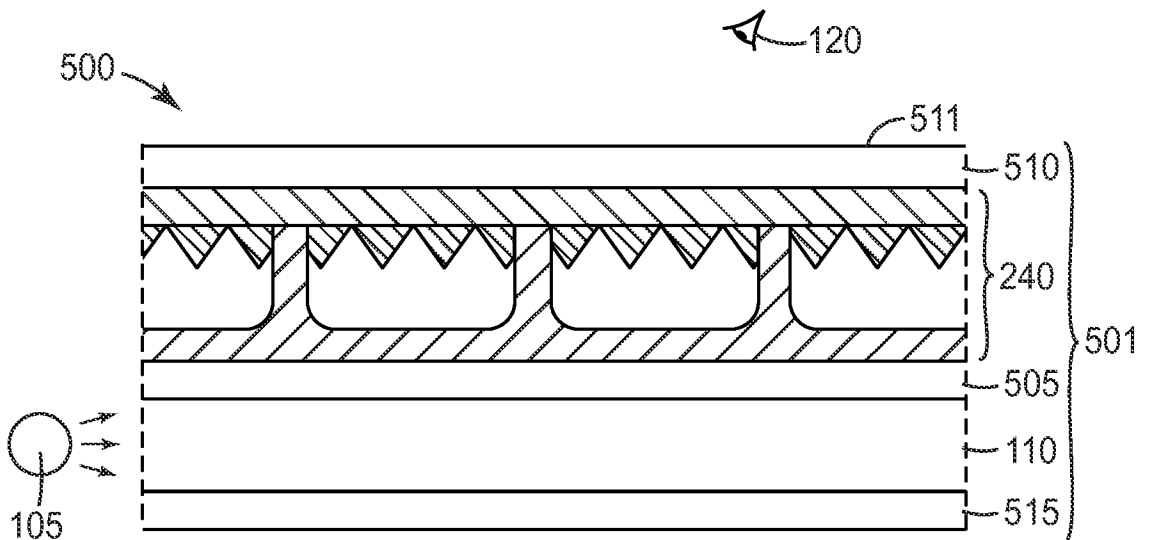

FIG. 5

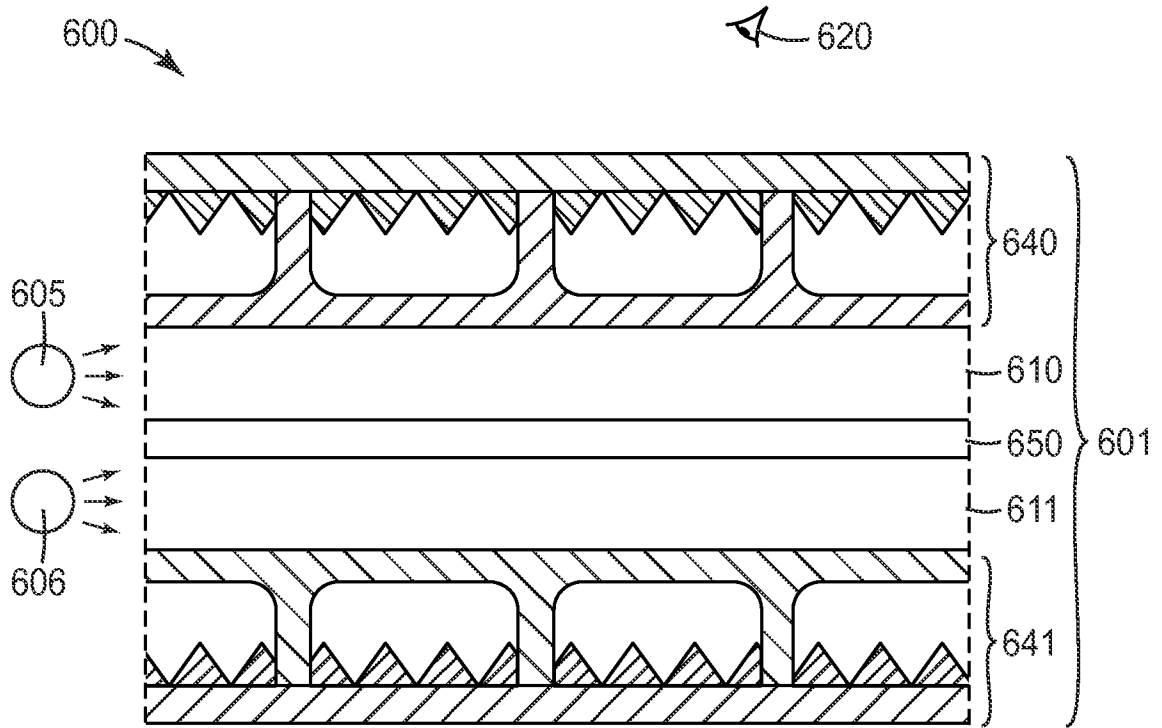

FIG. 6 621

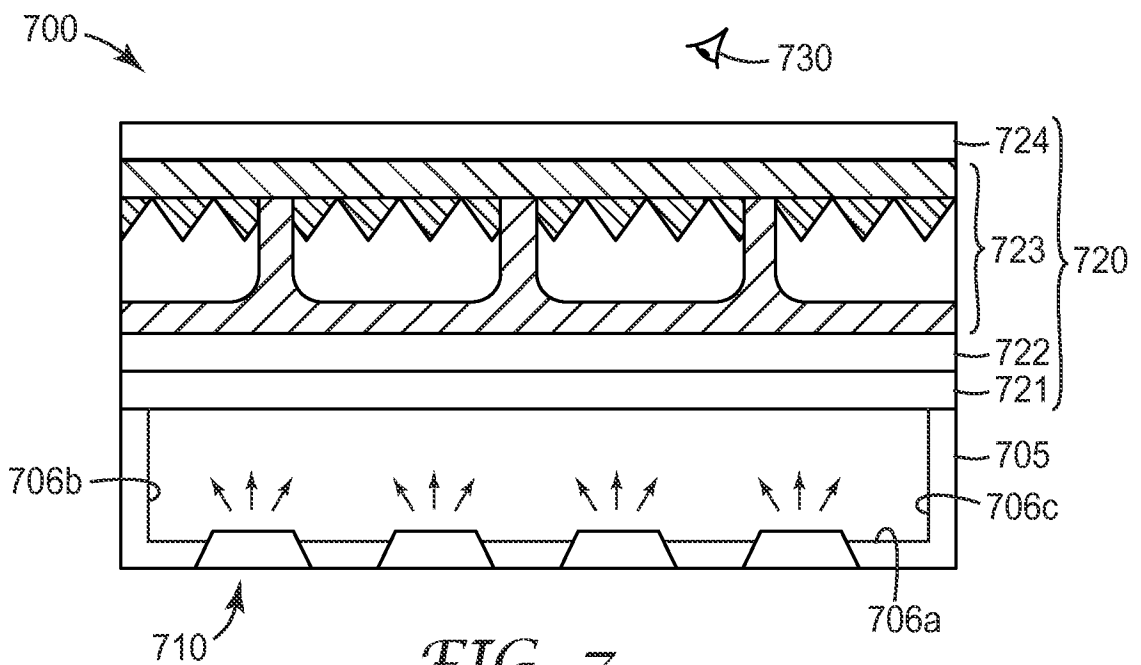

FIG. 7



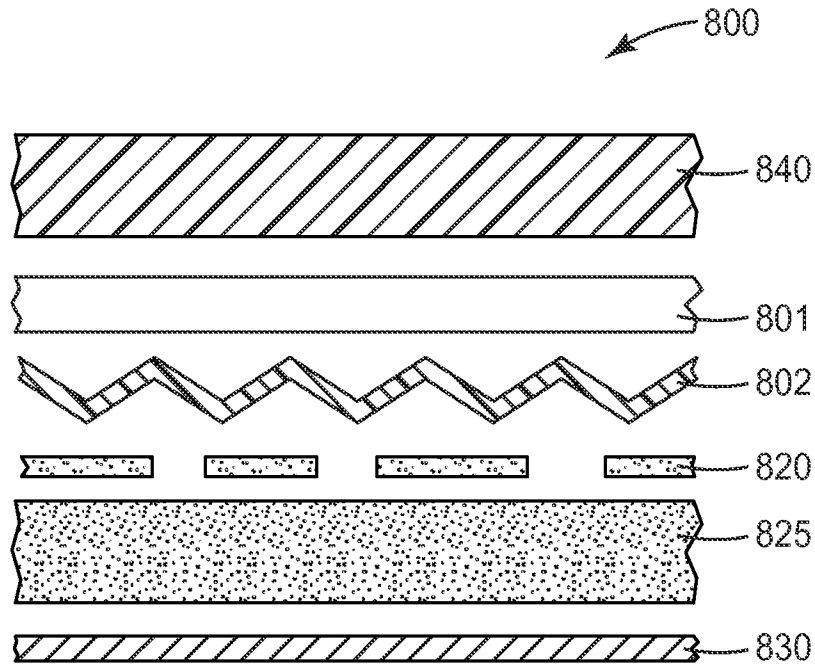

FIG. 8

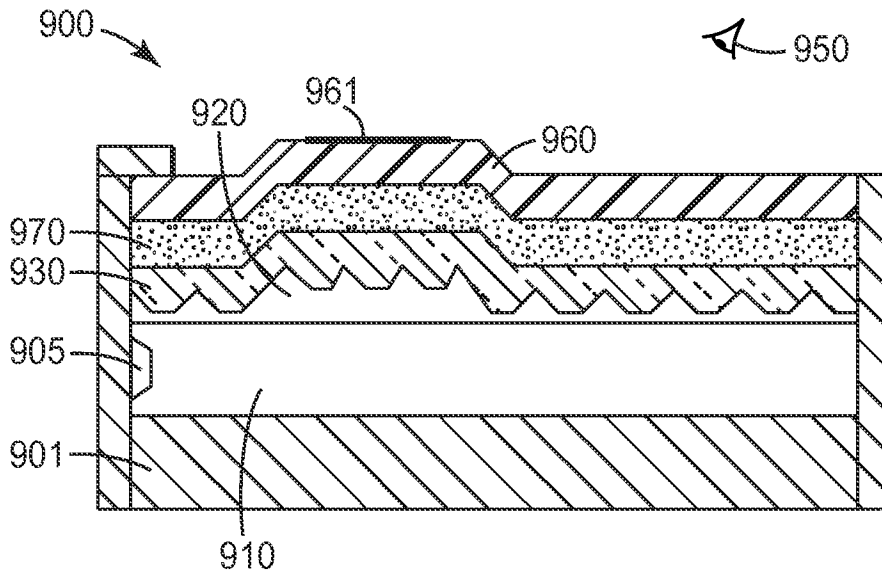

FIG. 9