



US 20050211612A1

(19) **United States**

(12) **Patent Application Publication**

**Mattson, JR. et al.**

(10) **Pub. No.: US 2005/0211612 A1**

(43) **Pub. Date: Sep. 29, 2005**

(54) **WATER SUCTION PURIFICATION DEVICE**

(22) Filed: **Mar. 25, 2004**

(76) Inventors: **Roy W. Mattson JR.**, Longmont, CO (US); **Paulette C. Ogden**, Longmont, CO (US); **Philip I. Ogden**, Longmont, CO (US)

**Publication Classification**

(51) **Int. Cl.<sup>7</sup> .....** E04H 3/16  
(52) **U.S. Cl. ....** 210/169

Correspondence Address:  
**ROY W. MATTSON JR.**  
**1732 SPENCER STREET**  
**LONGMONT, CO 80501 (US)**

(57) **ABSTRACT**

A system to sanitize water through the use of ions for a whirlpool bathtub, spa and other water vessels.

(21) Appl. No.: **10/808,500**

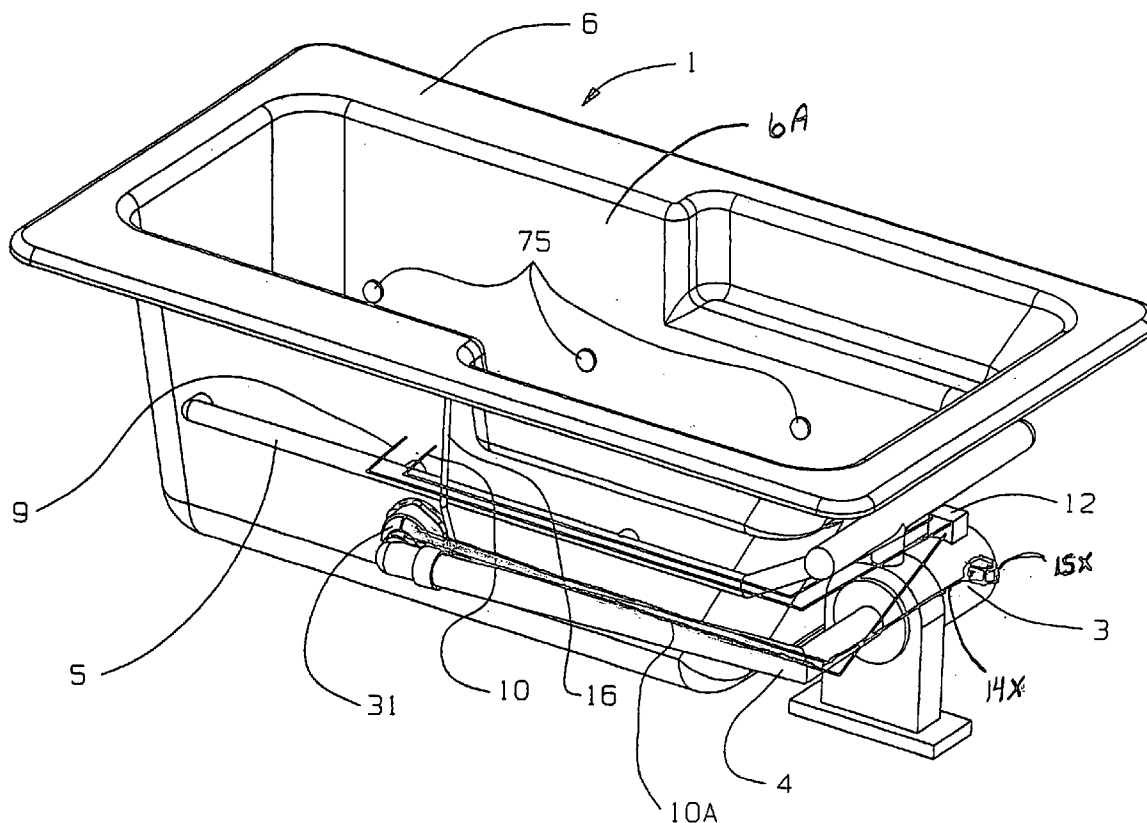

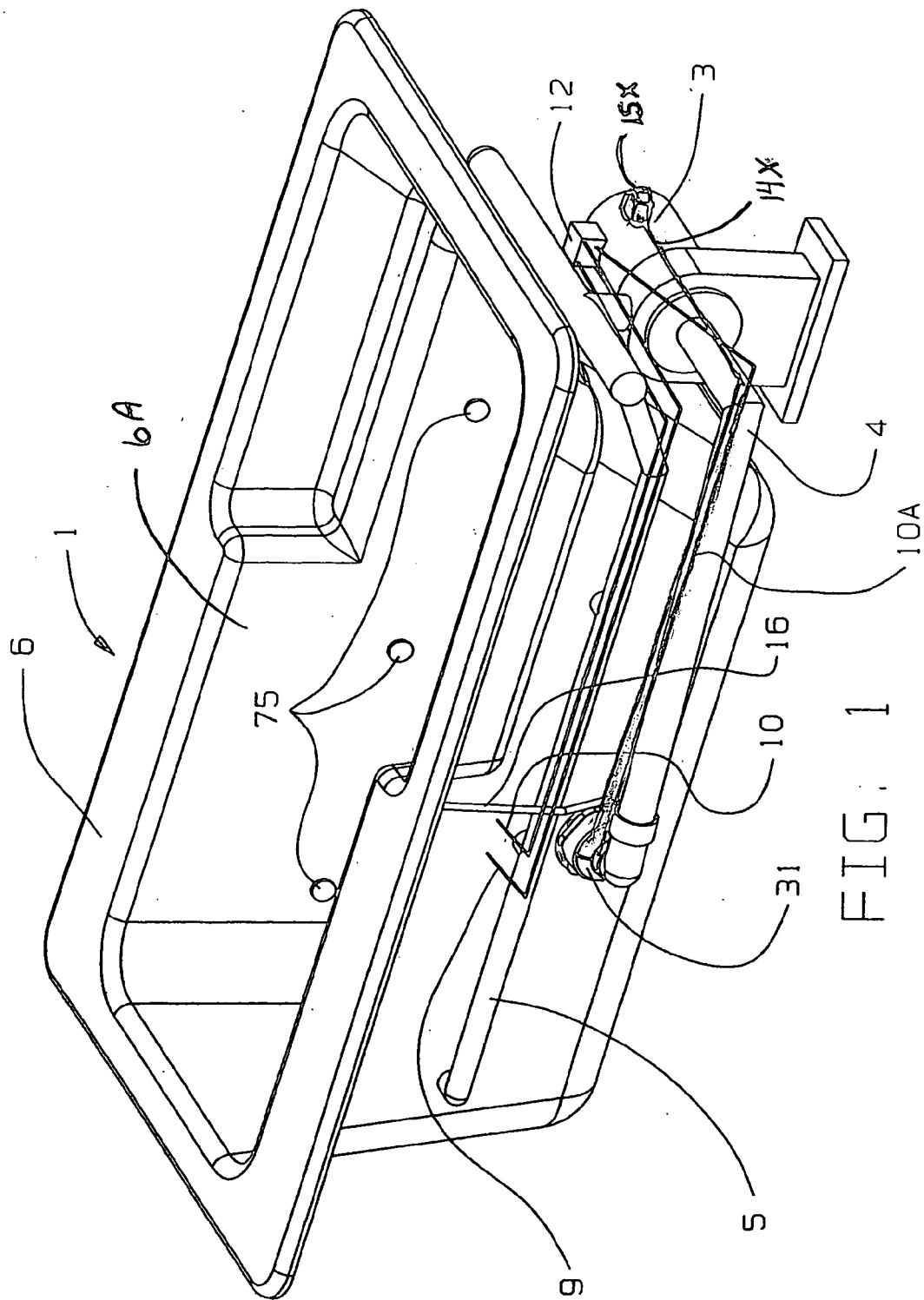

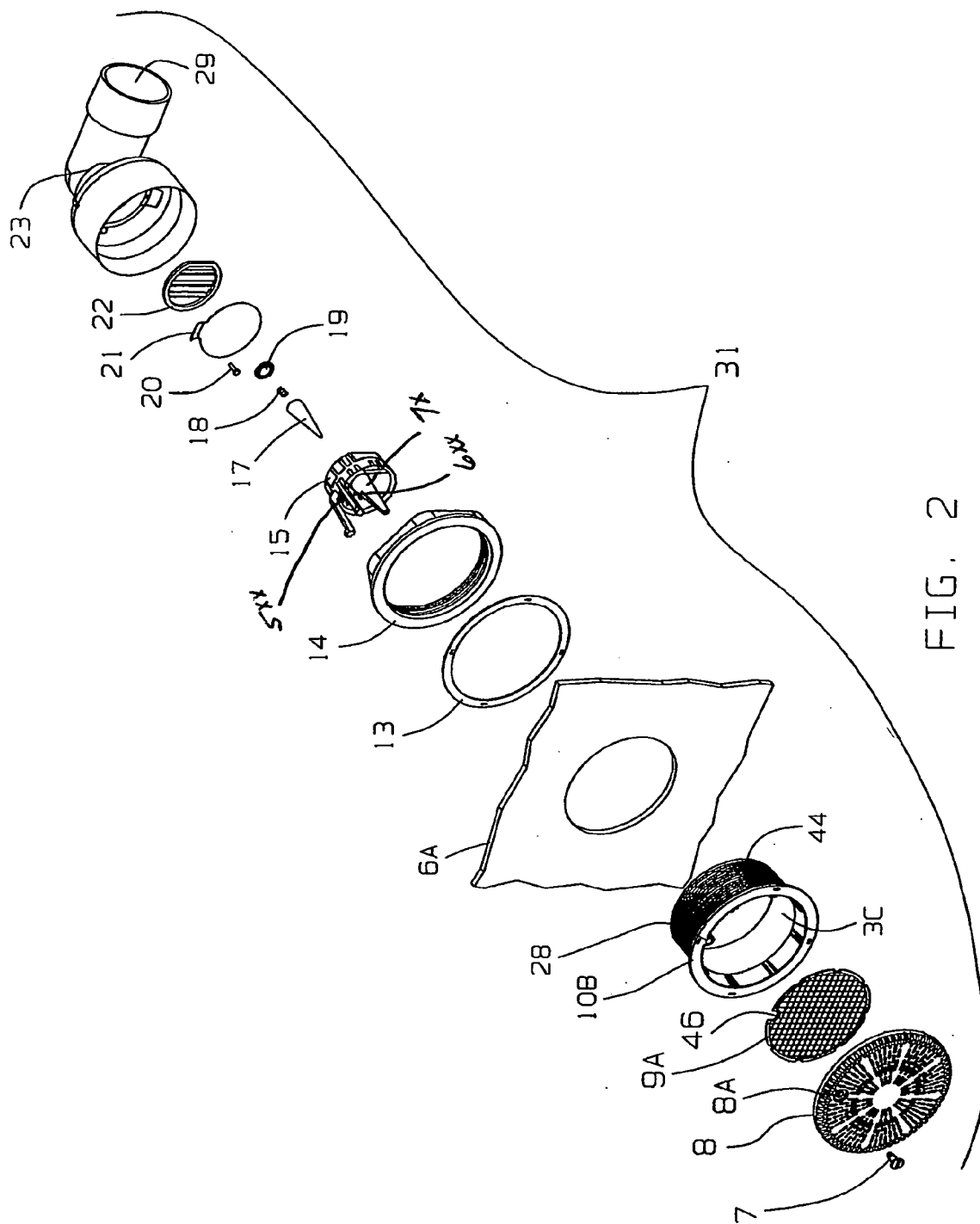
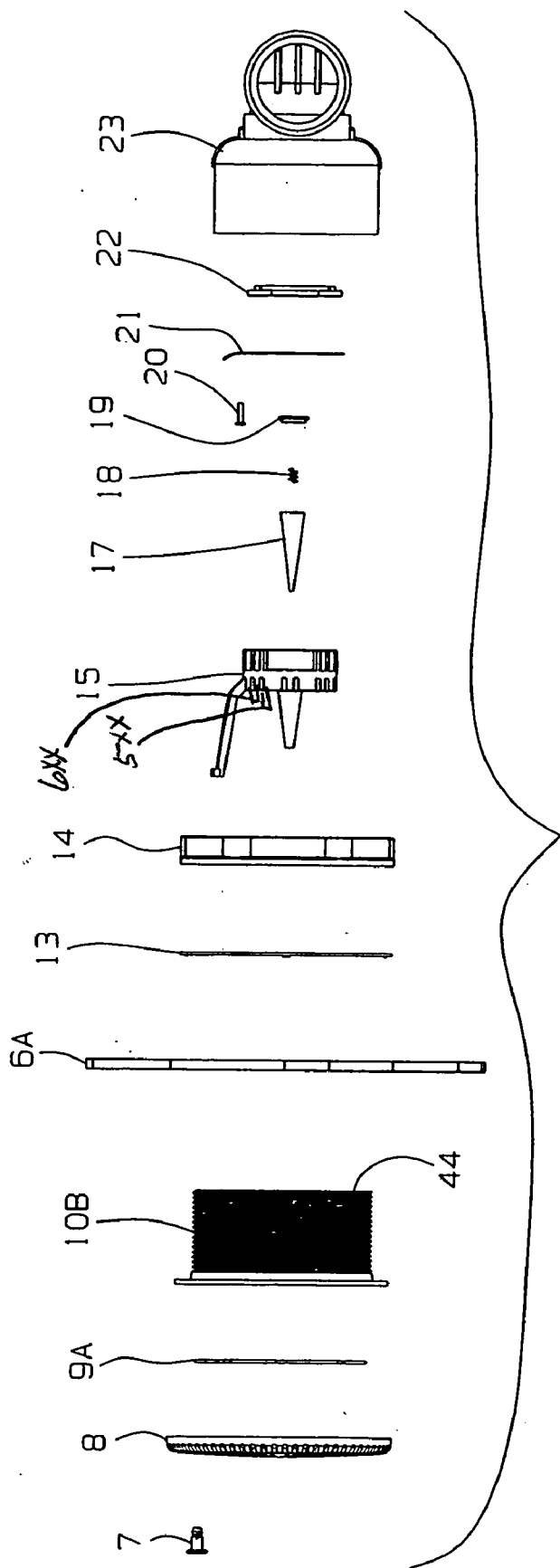

FIG. 2



31  
FIG. 3

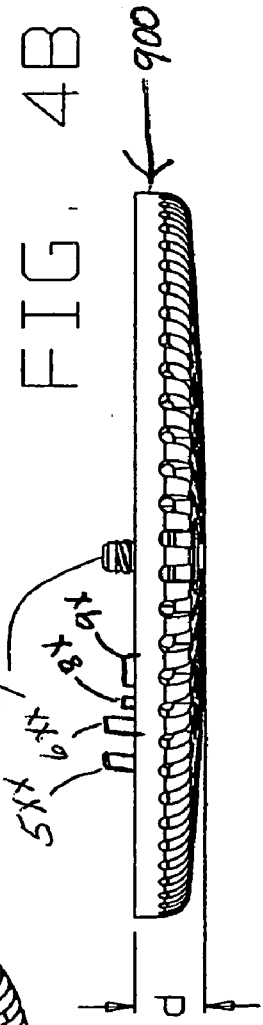
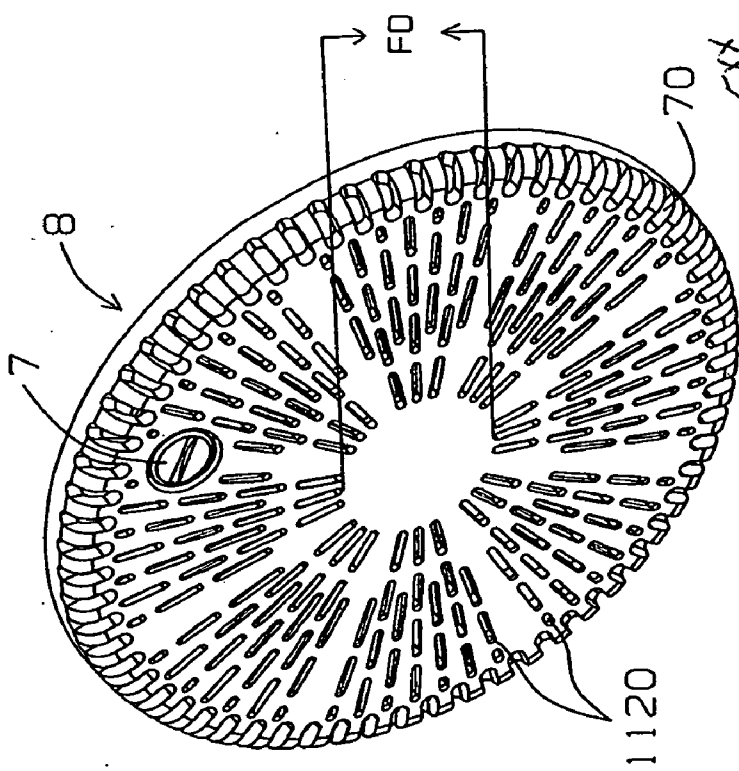
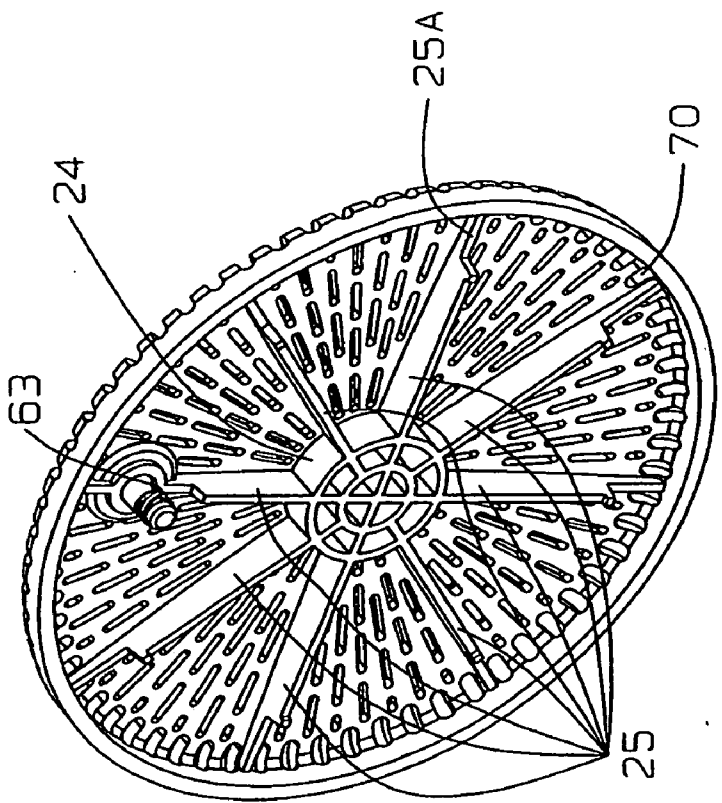

FIG. 4A

FIG. 4B

FIG. 4C

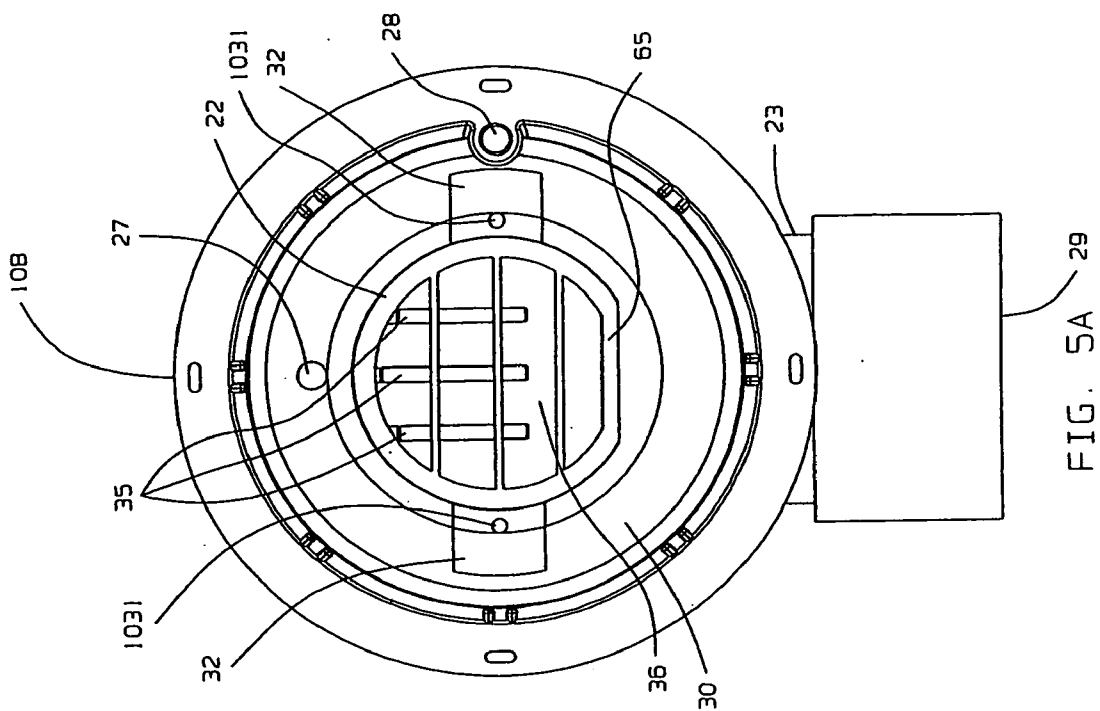

FIG. 5A 29

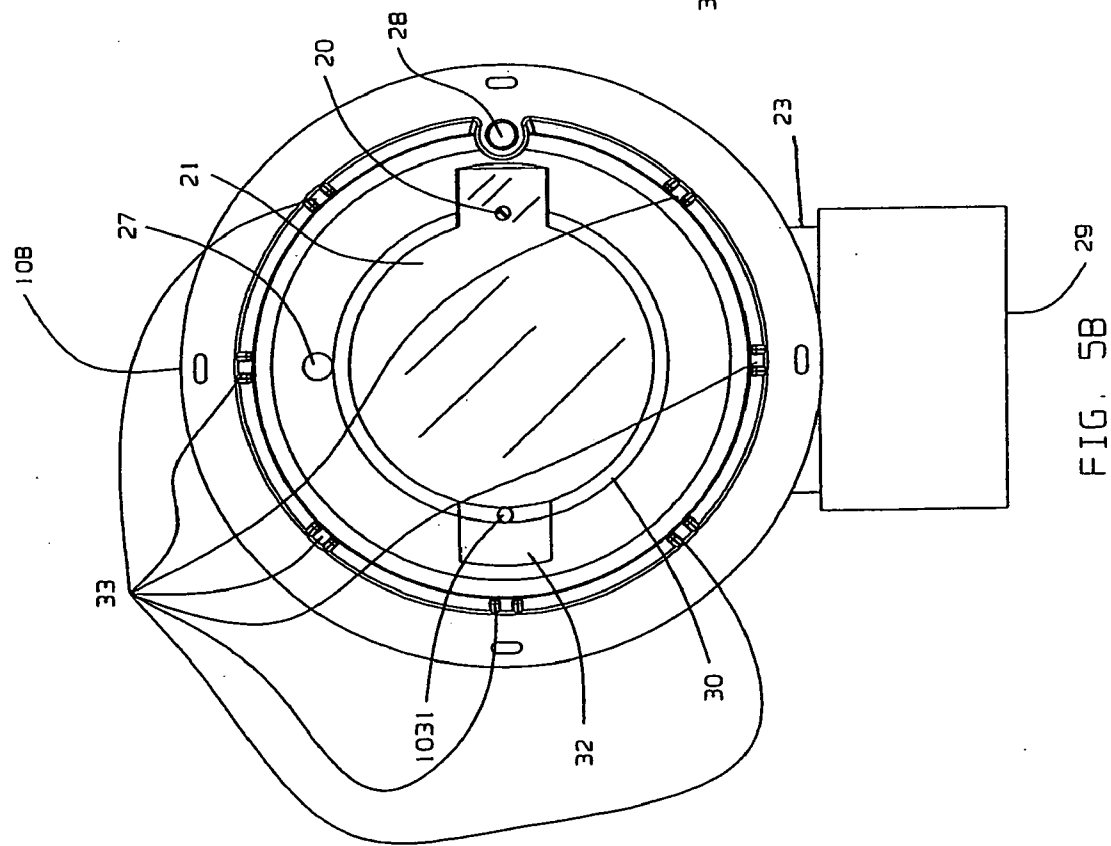

FIG. 5B 29

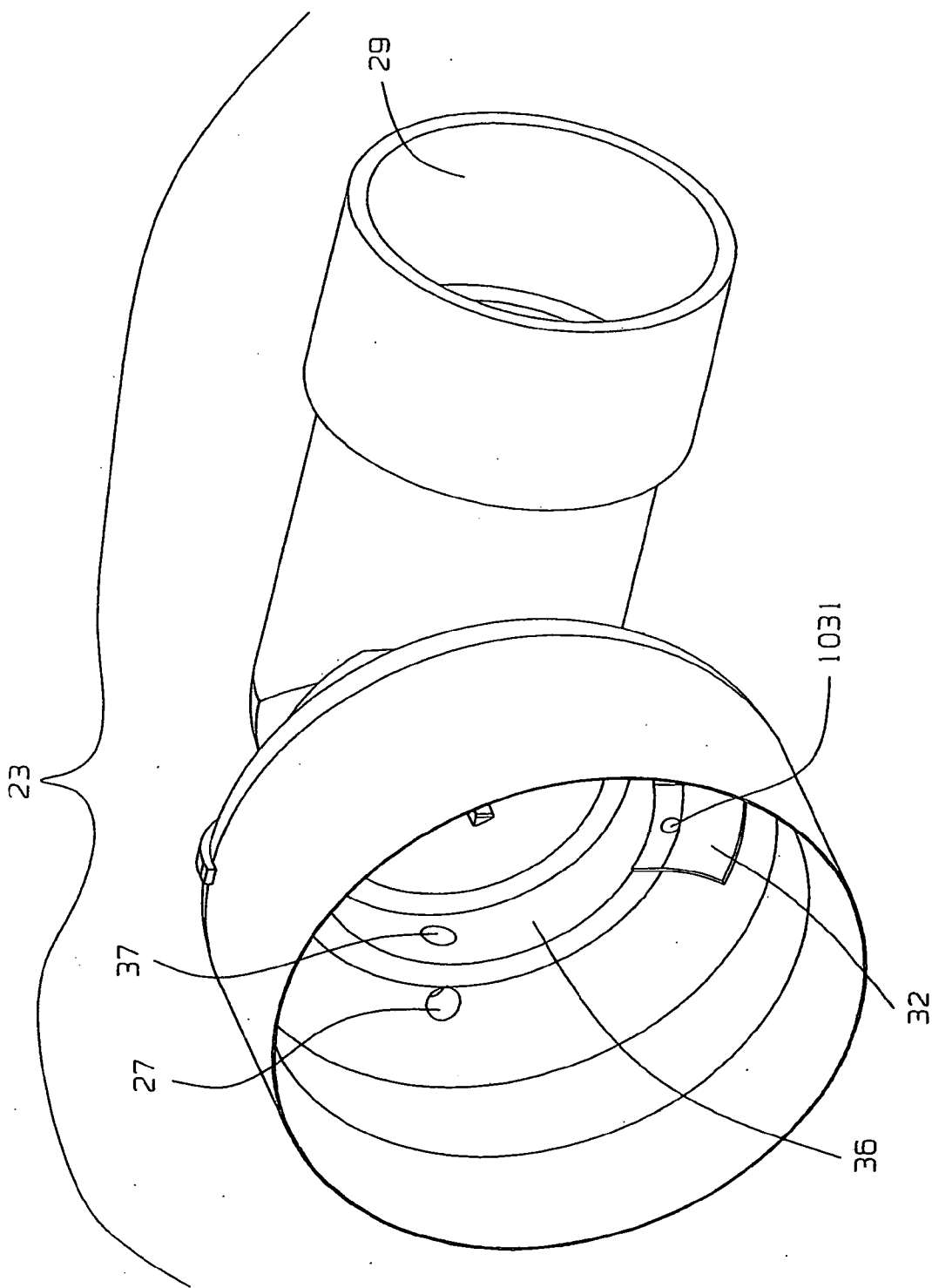

FIG. 6

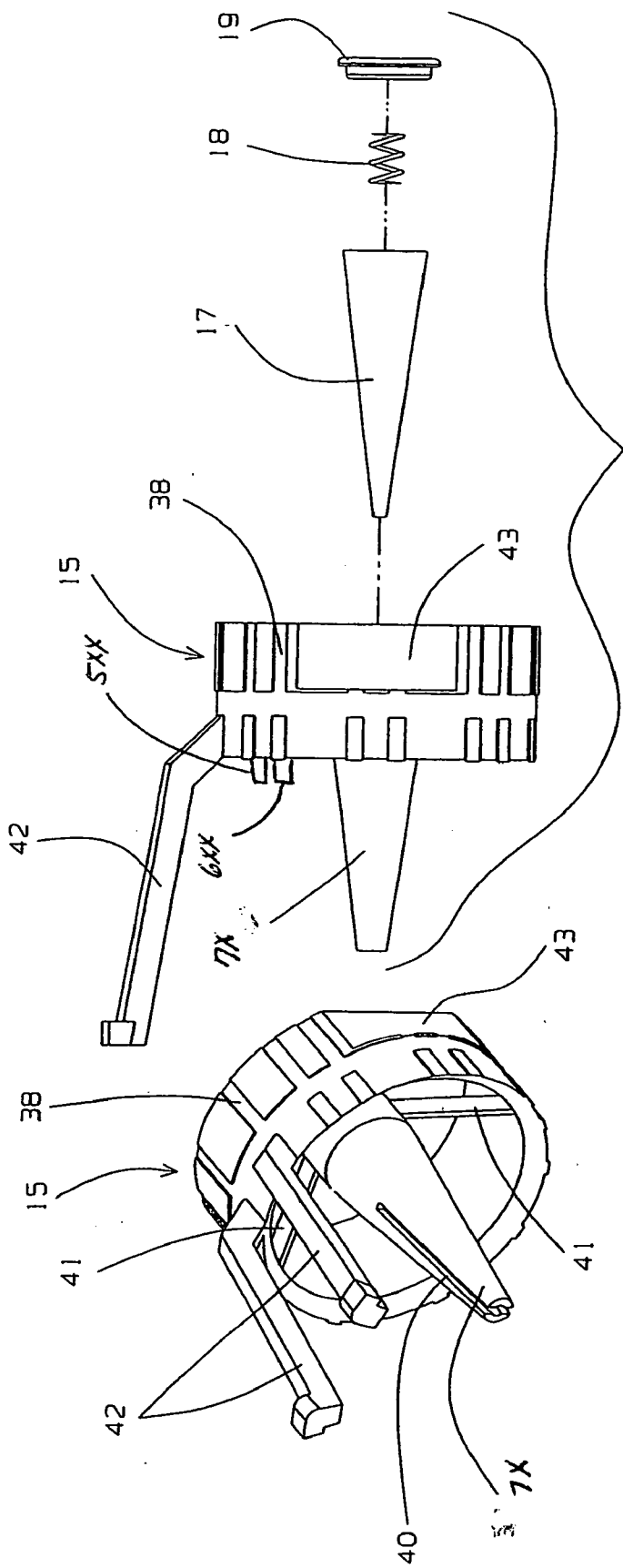

FIG. 7B

FIG. 7A



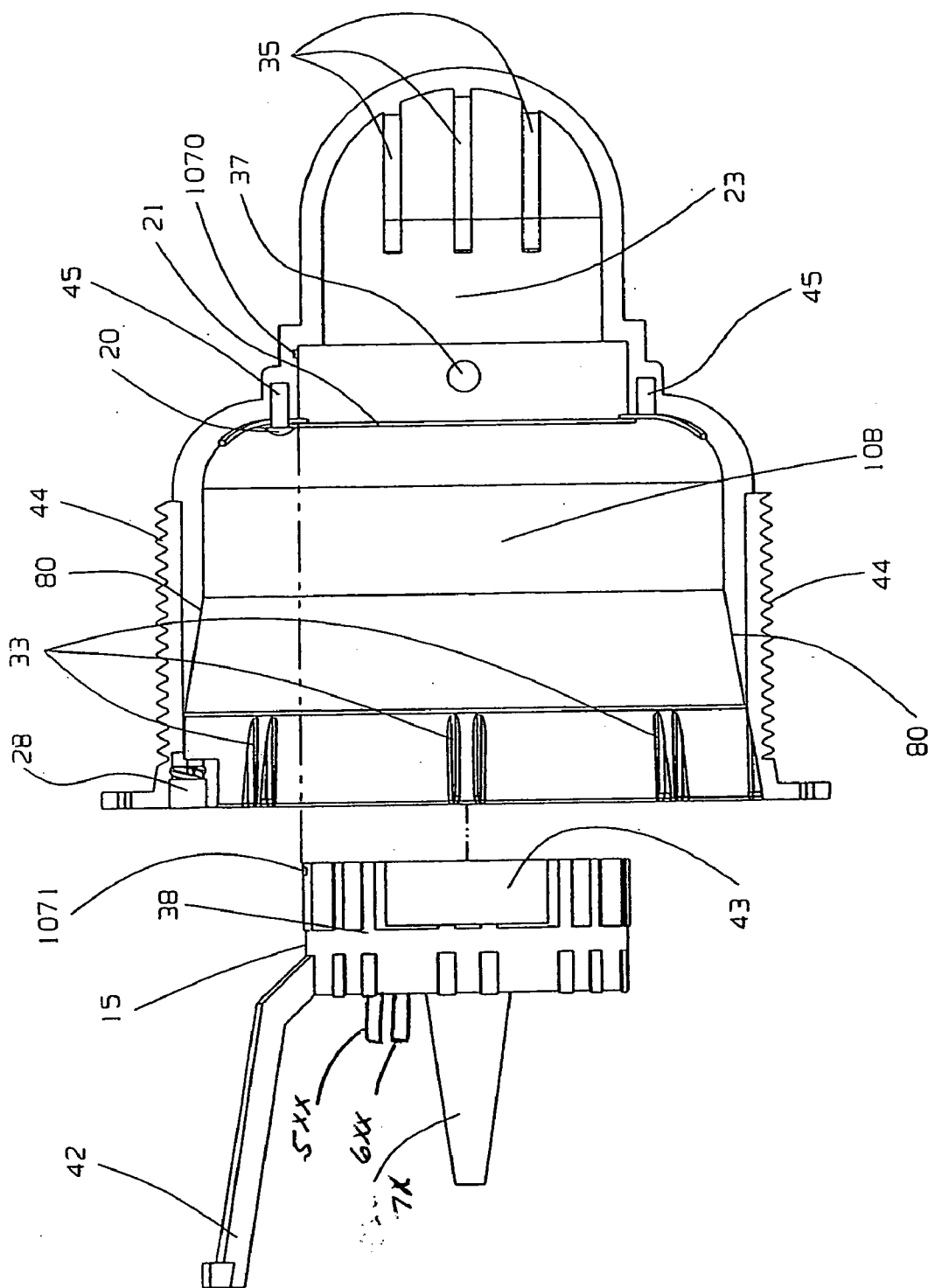

FIG. 8

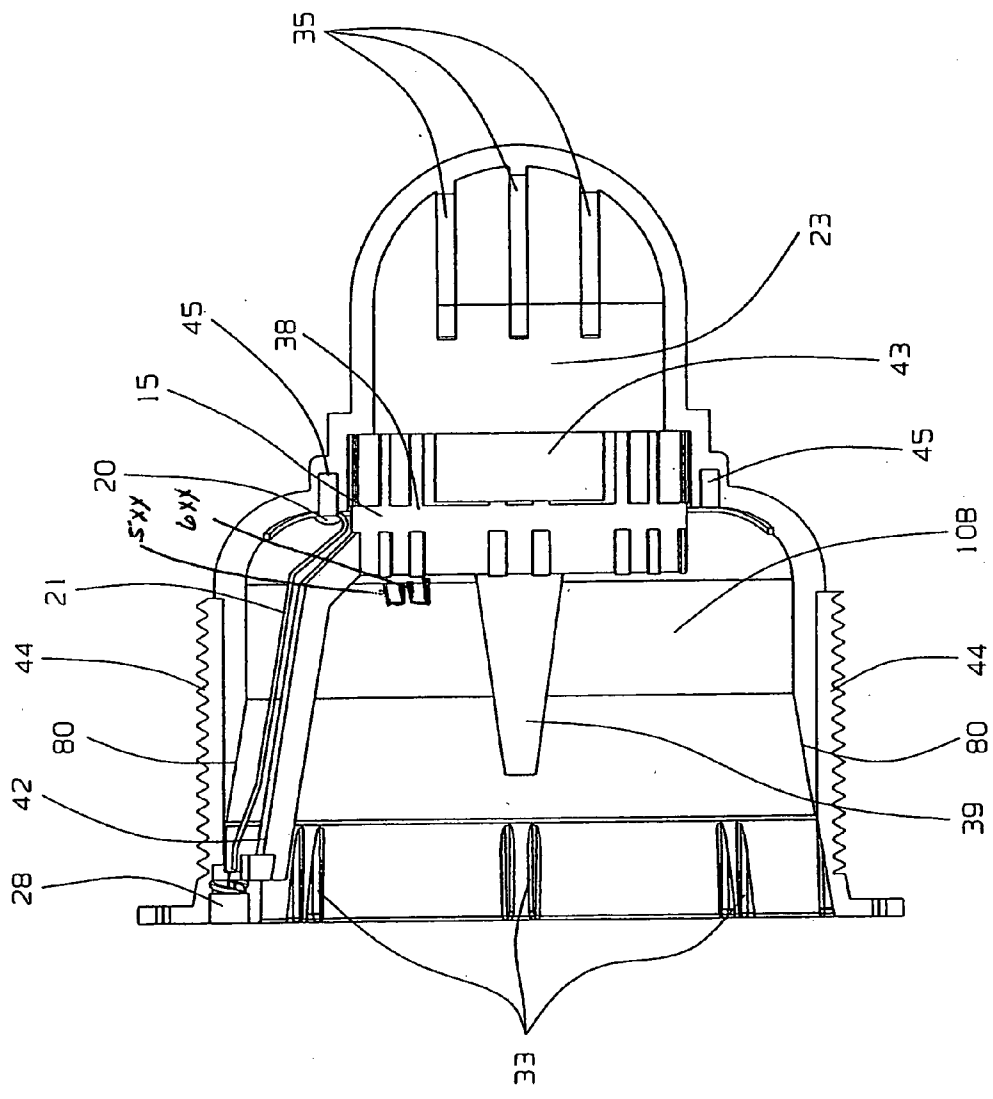

FIG. 9

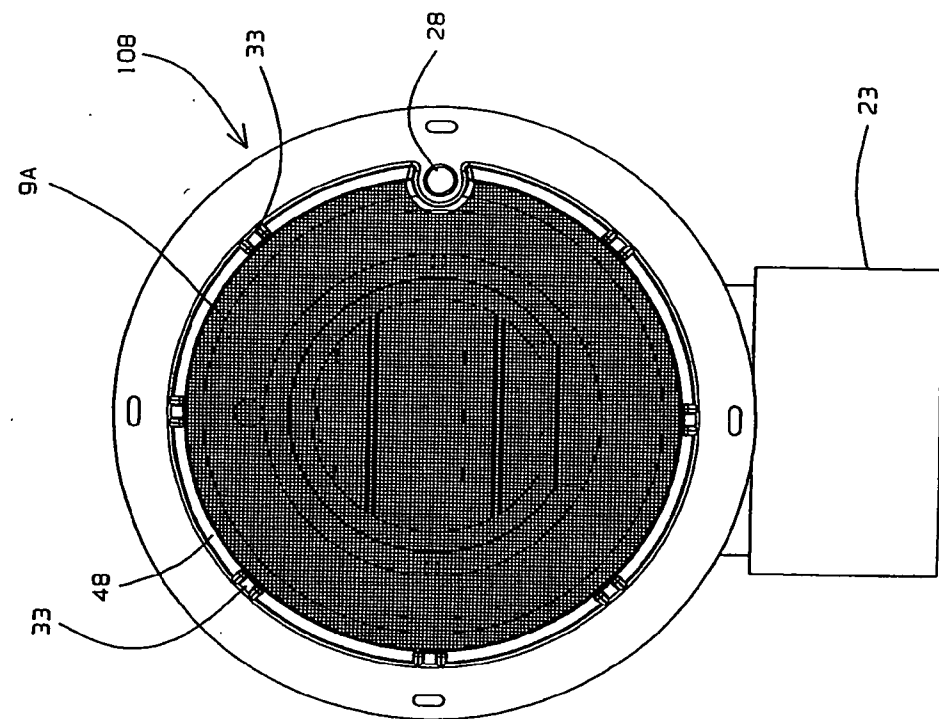

FIG. 10A

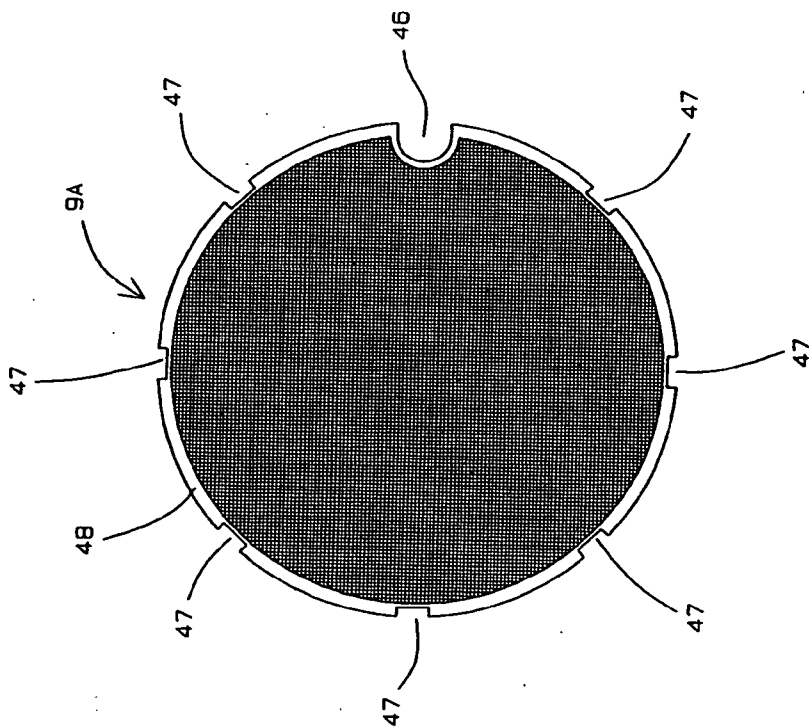

FIG. 10

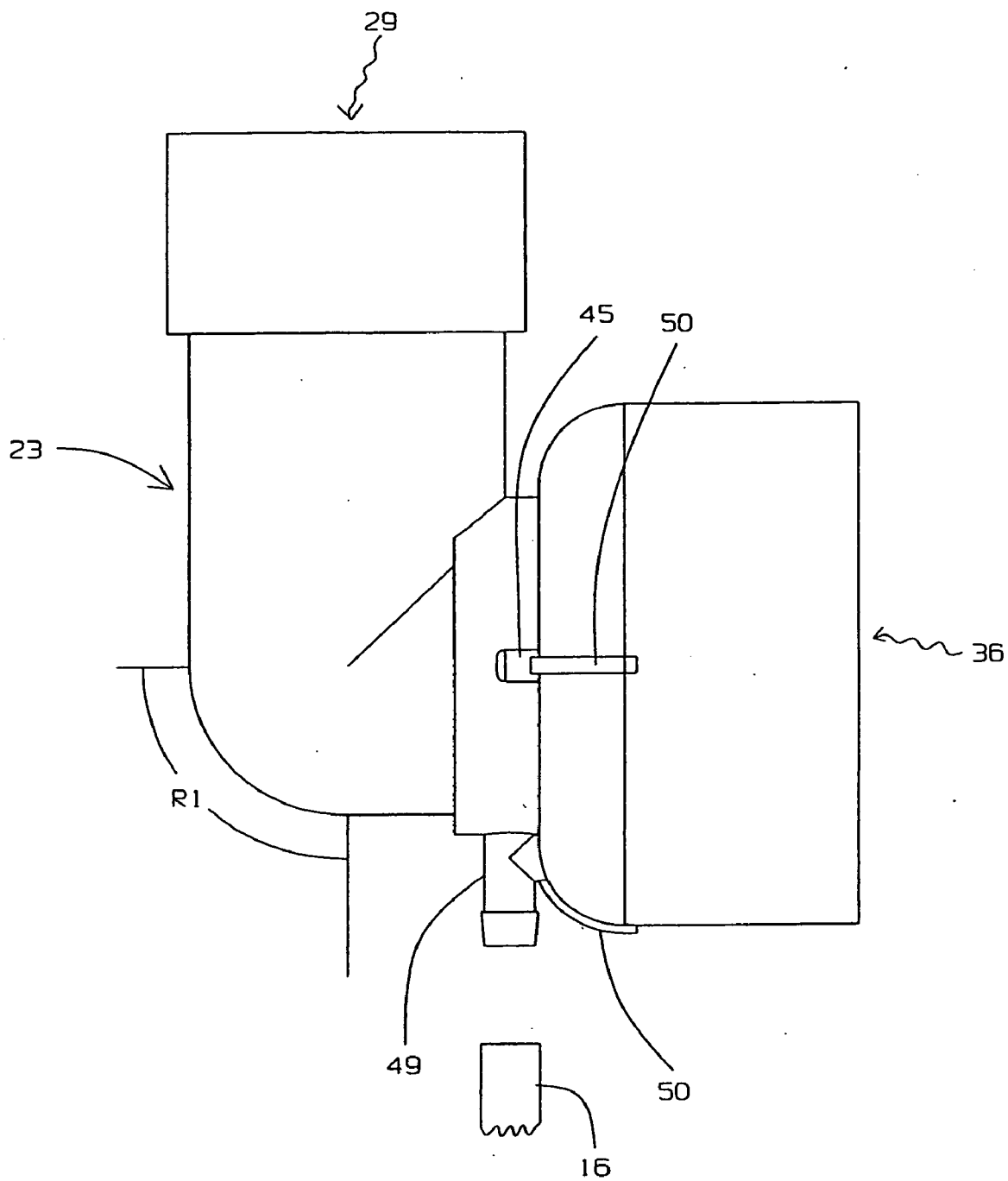

FIG. 11

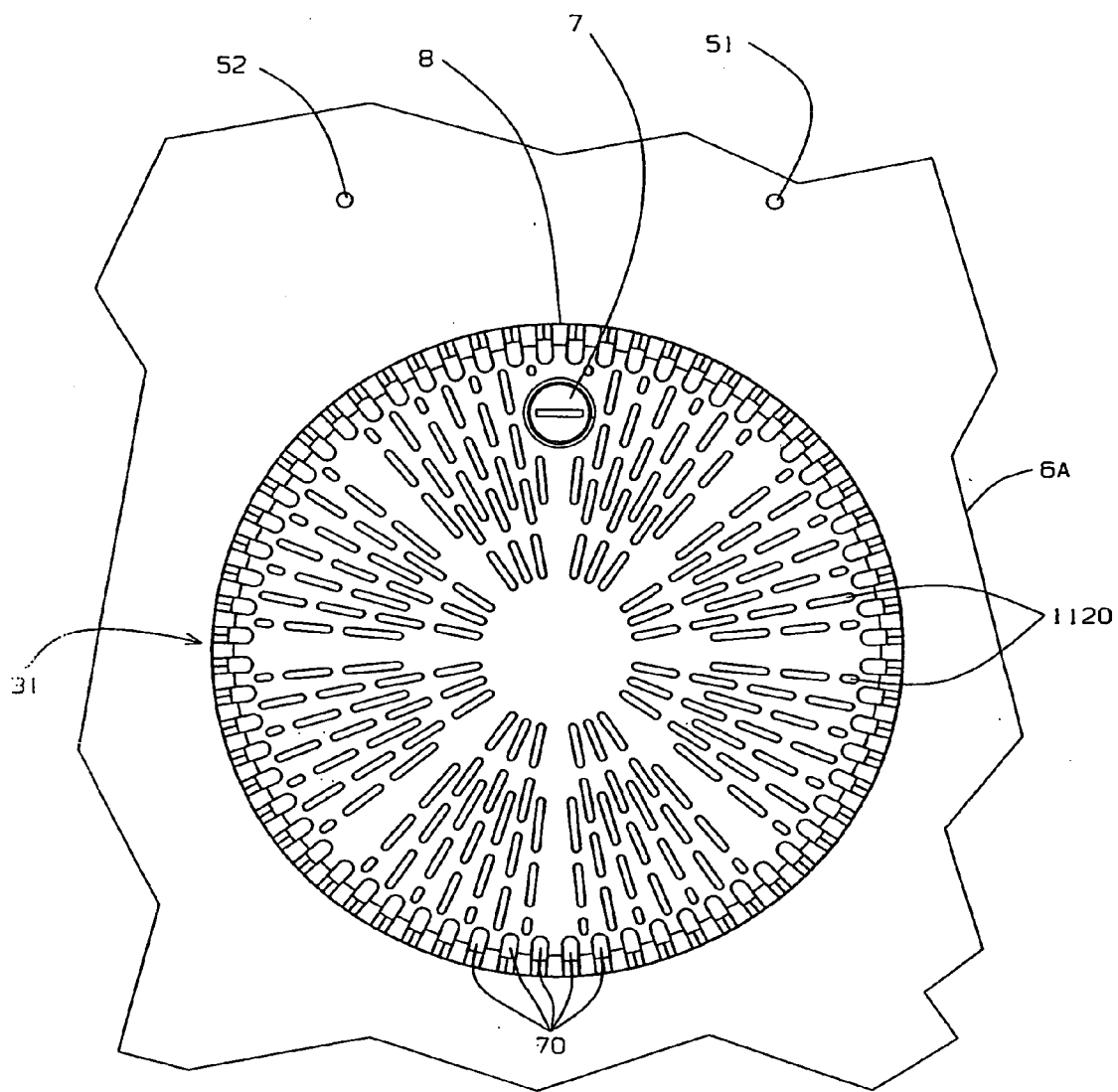

FIG. 12

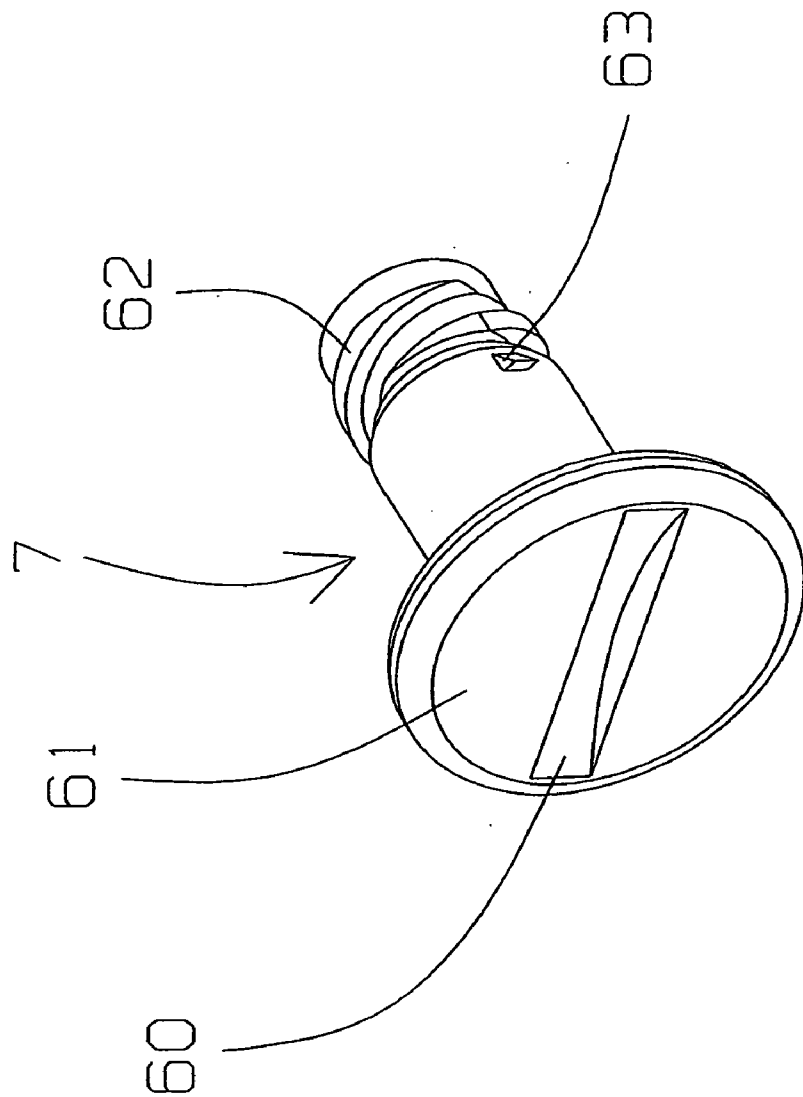

FIG. 13

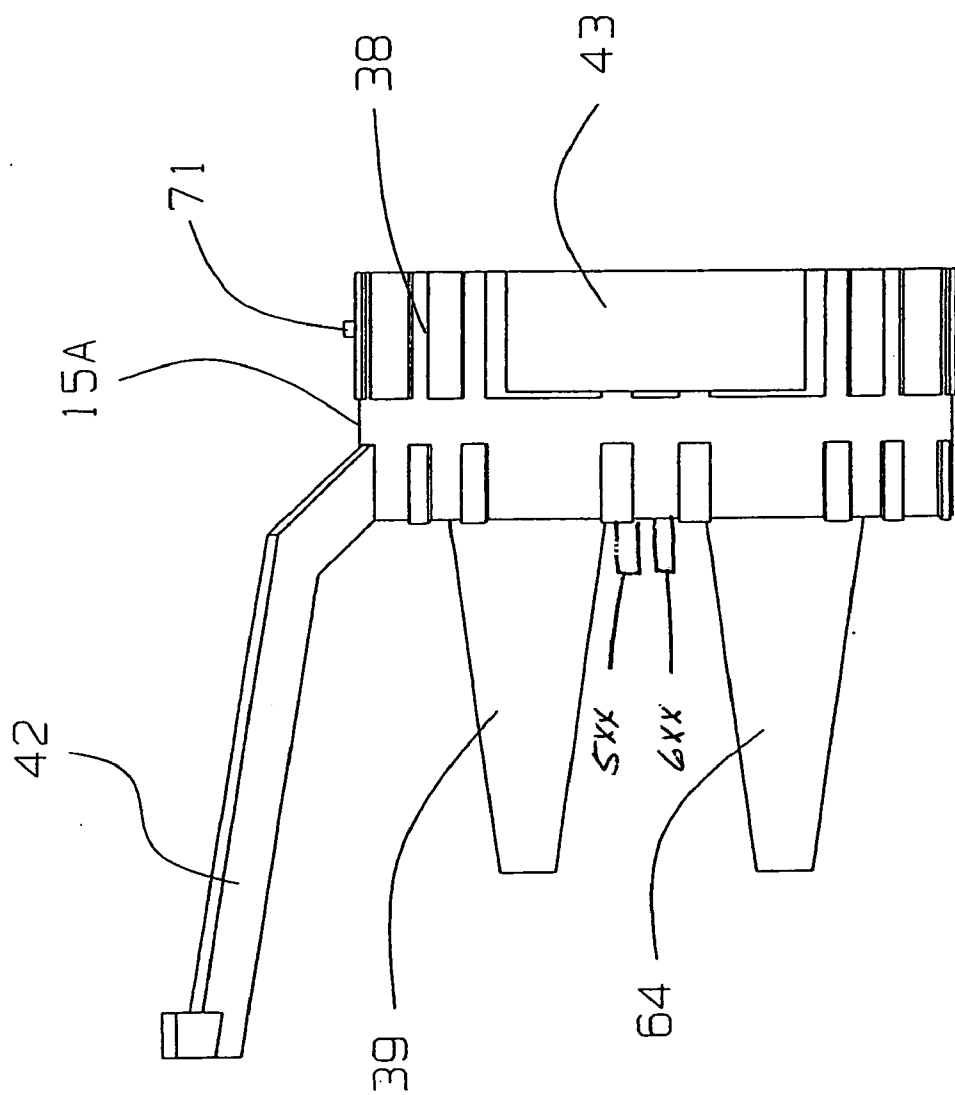

FIG. 14

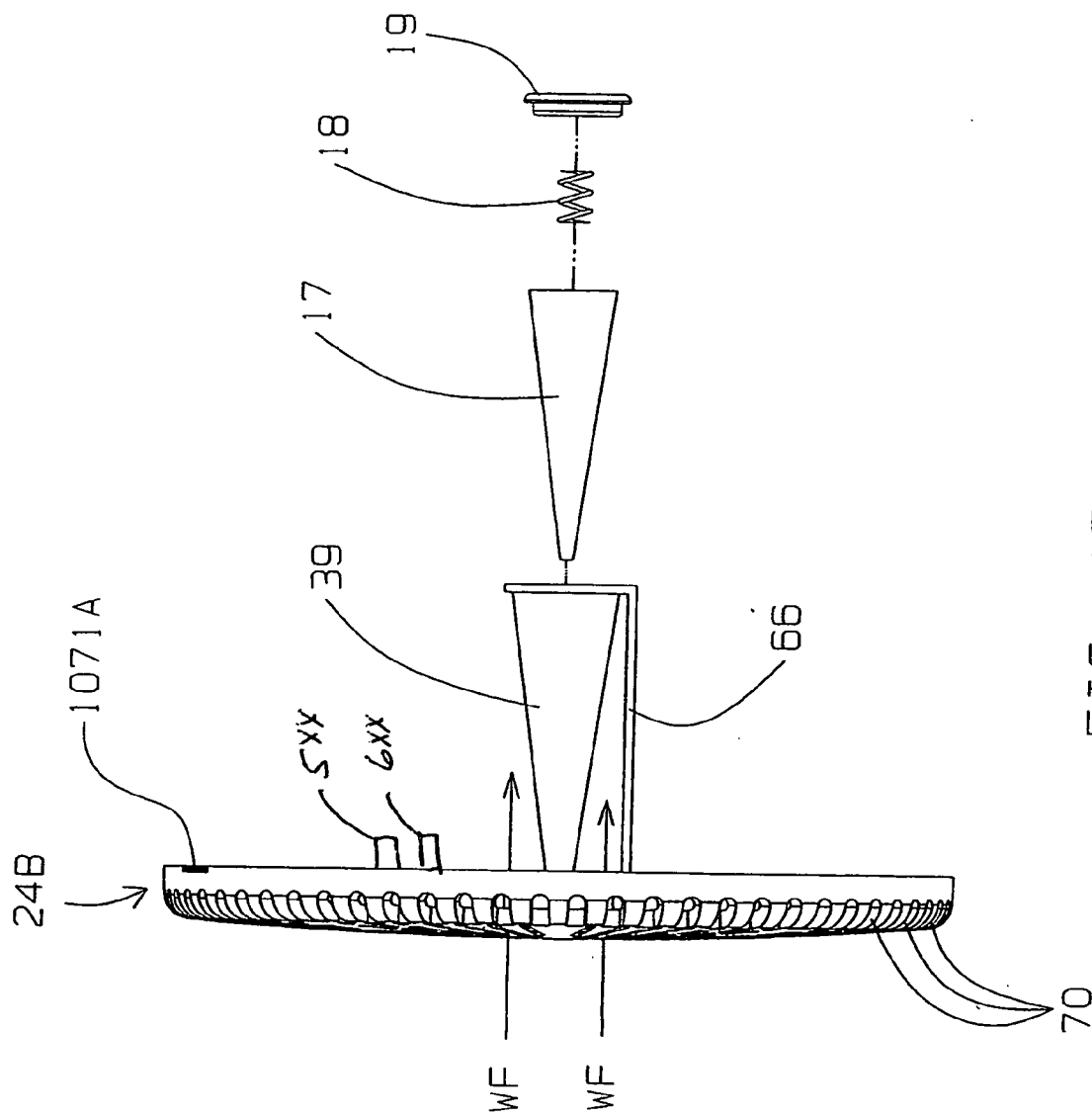

FIG. 15



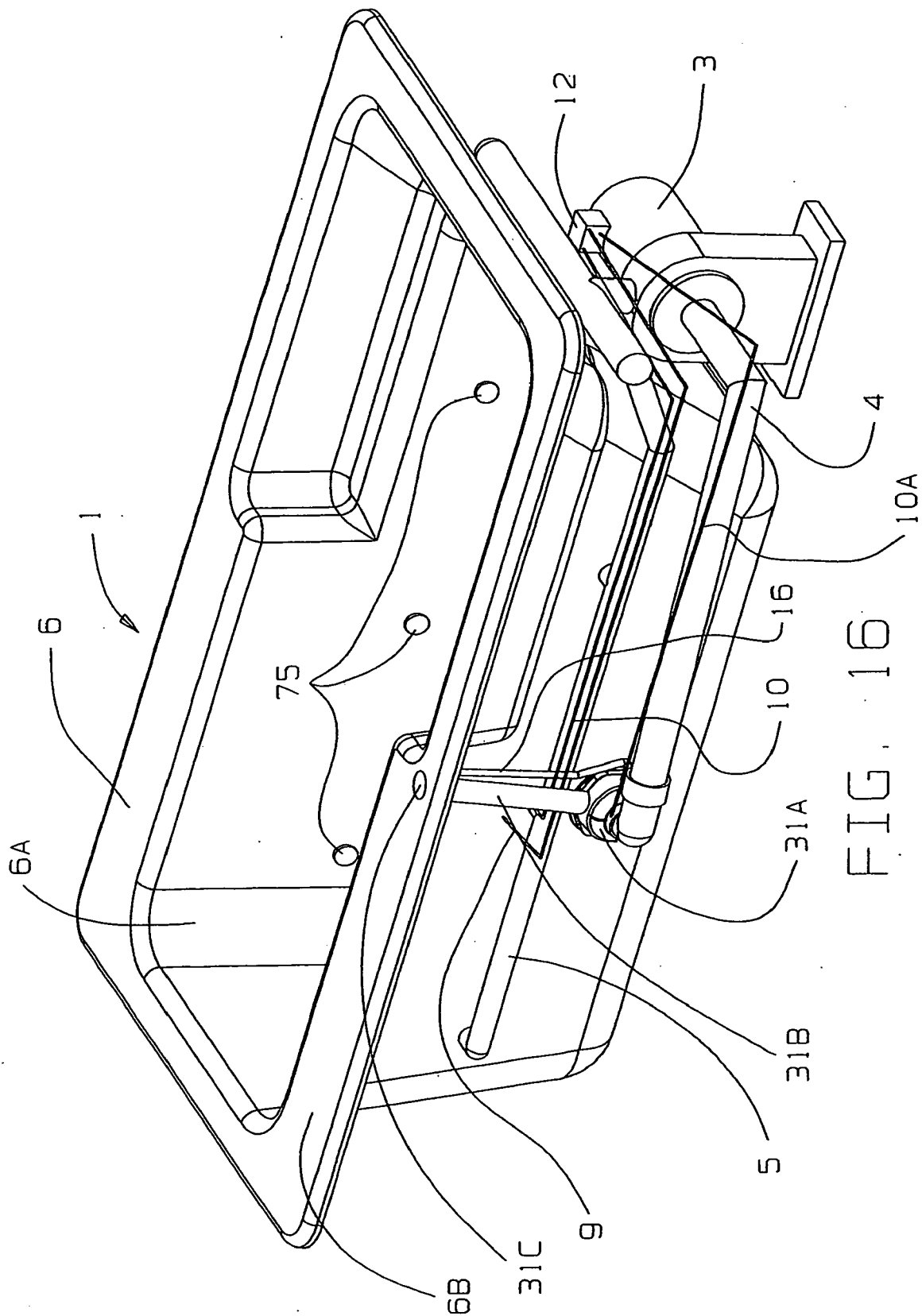

FIG. 16



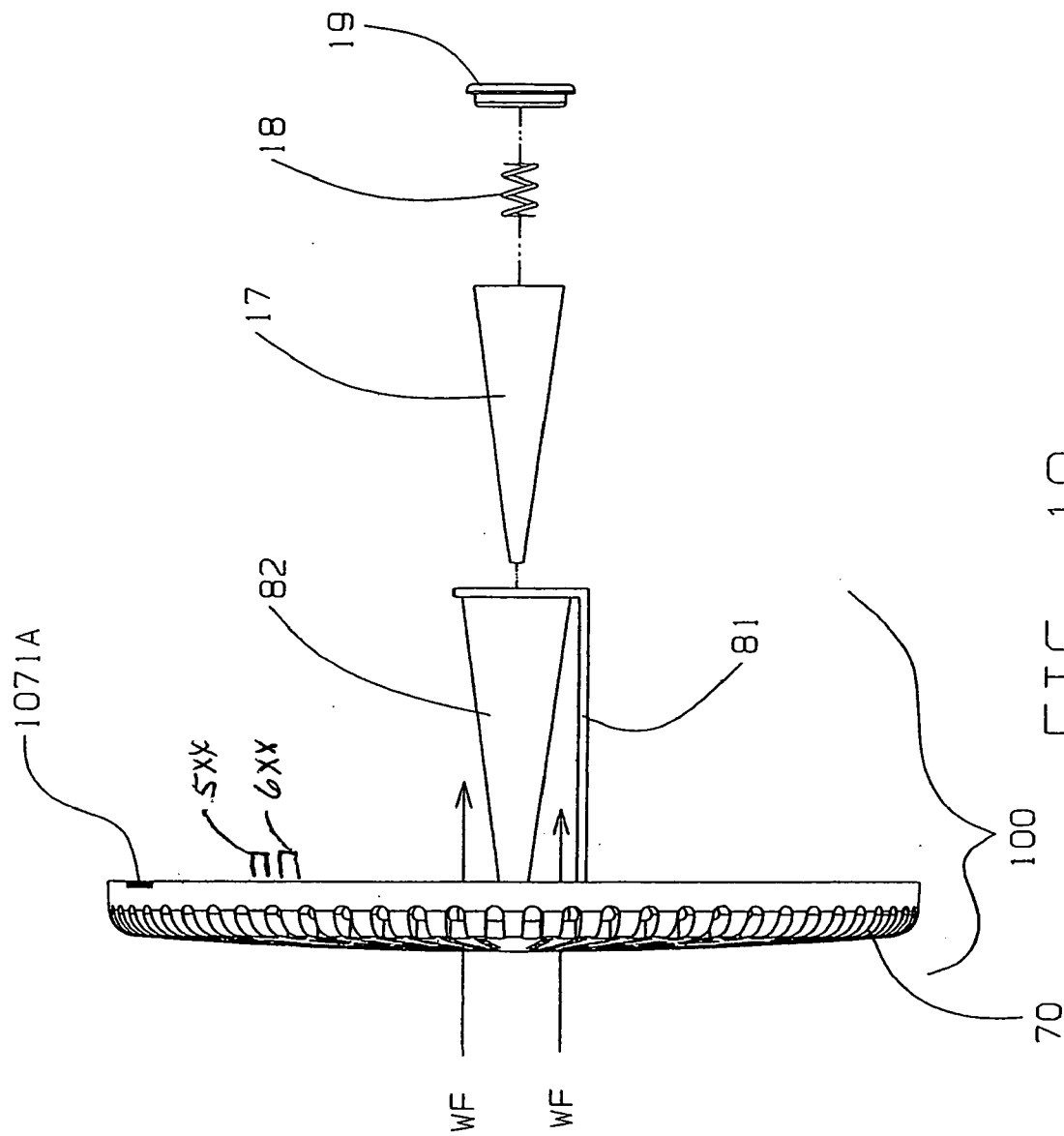

FIG. 18

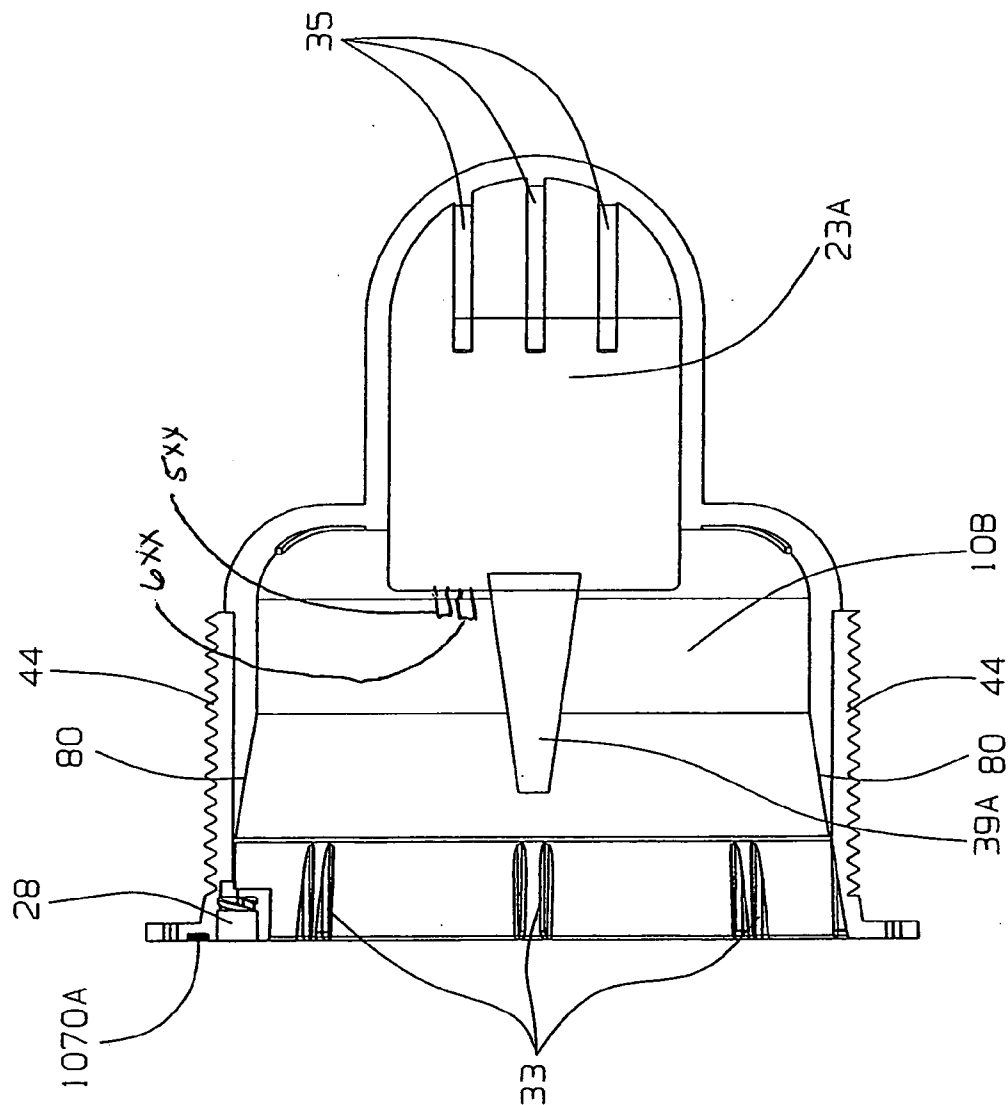

FIG. 19

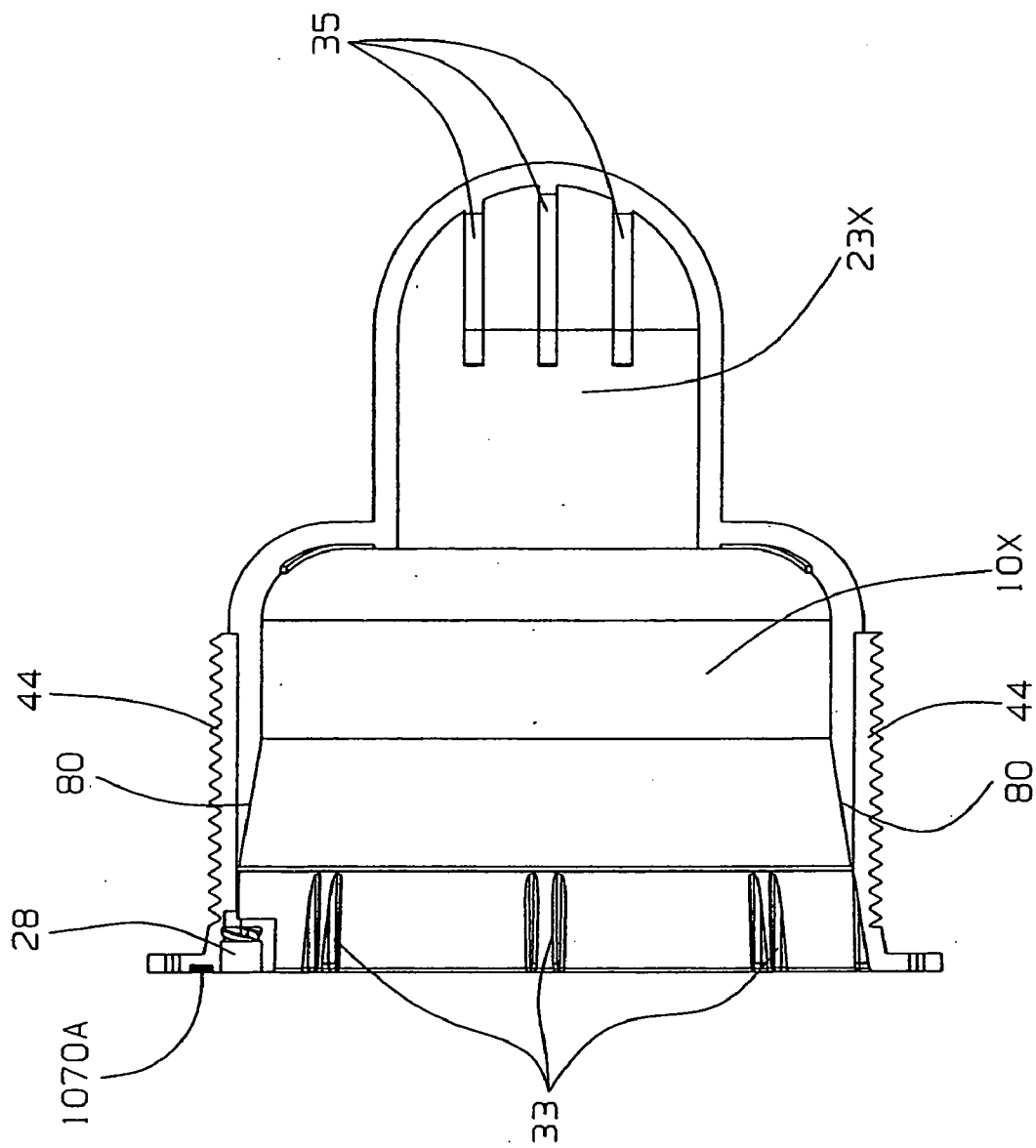

FIG. 20

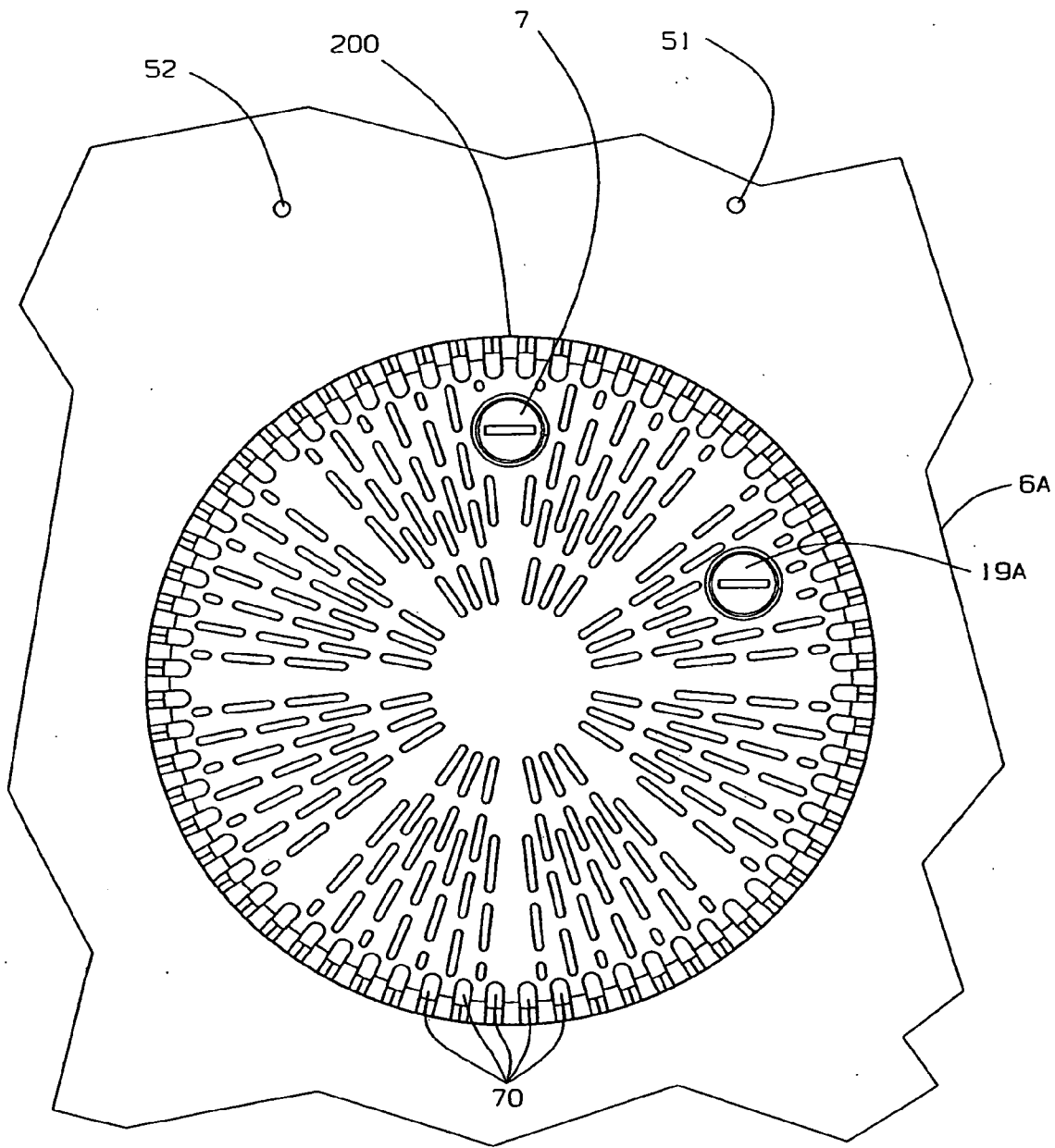

FIG. 21

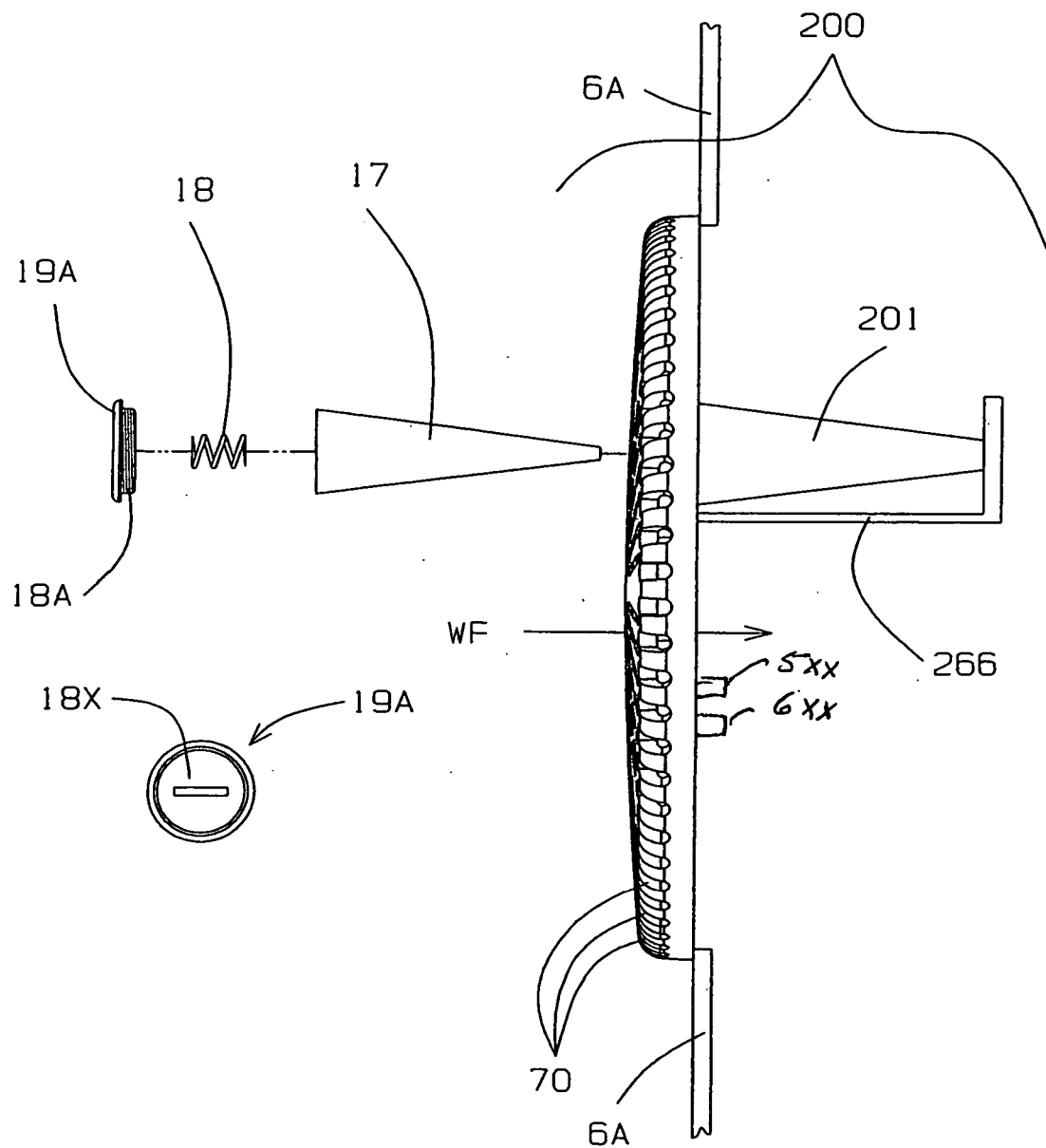

FIG. 22

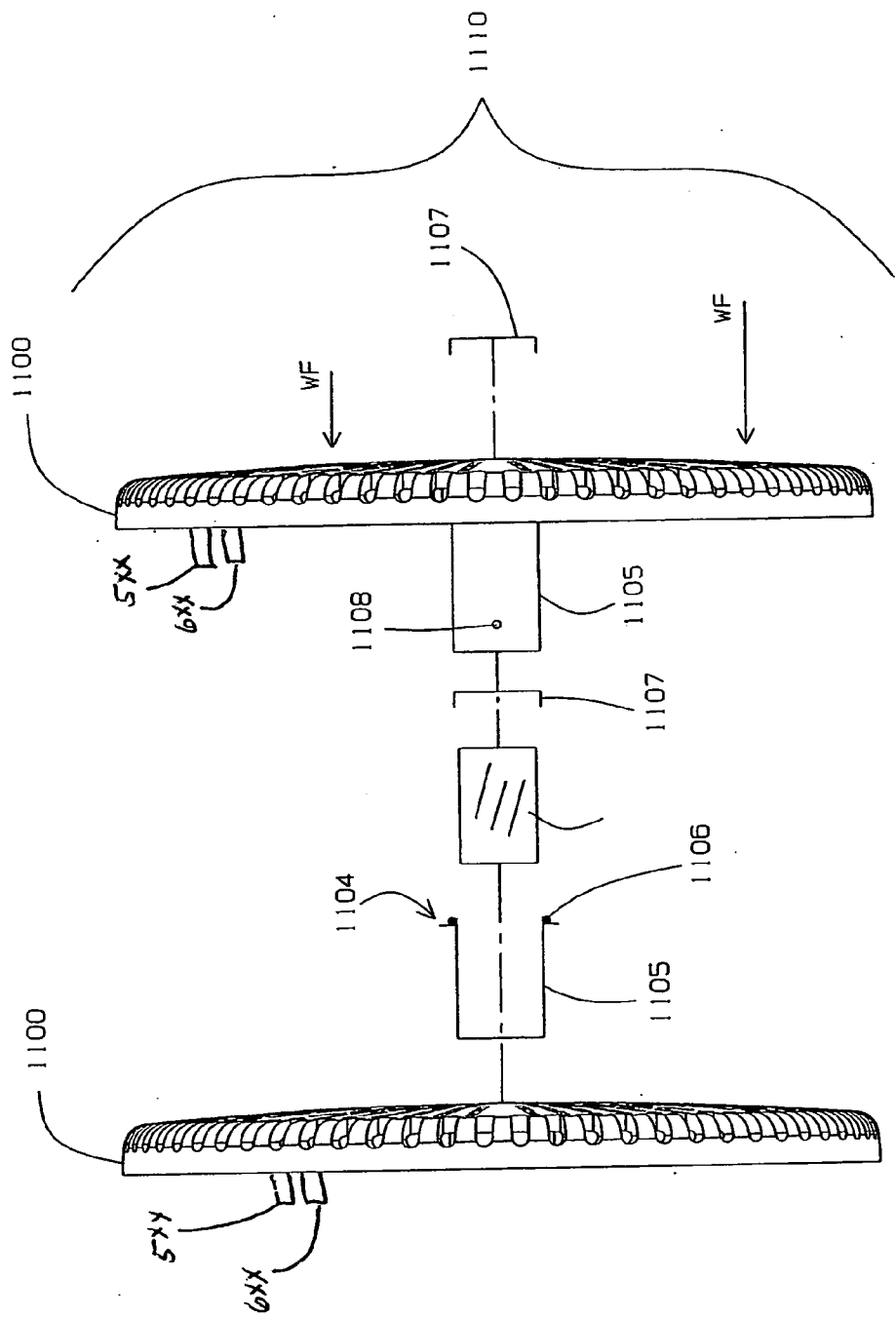

FIG. 23B

FIG. 23A



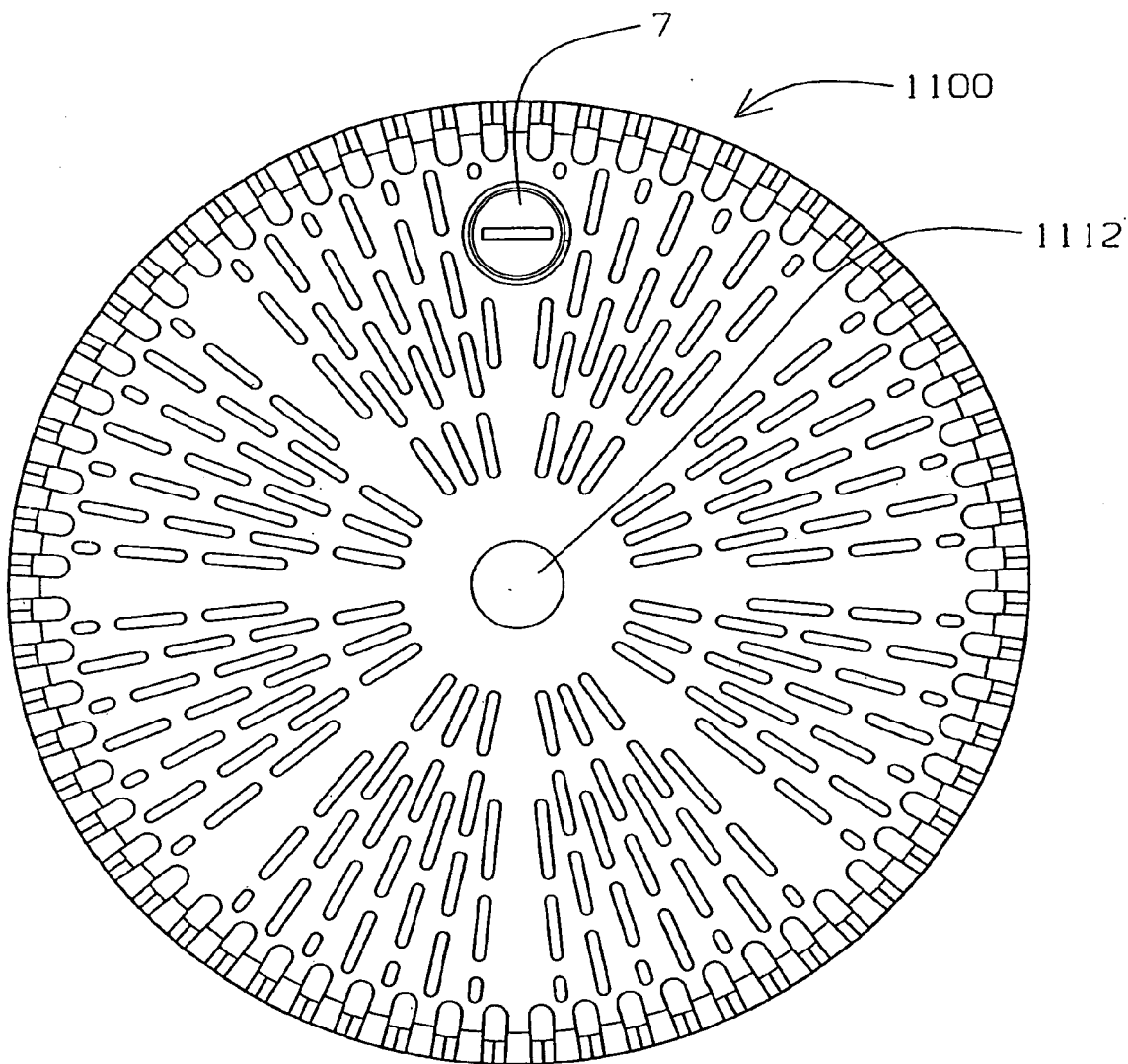

FIG. 24

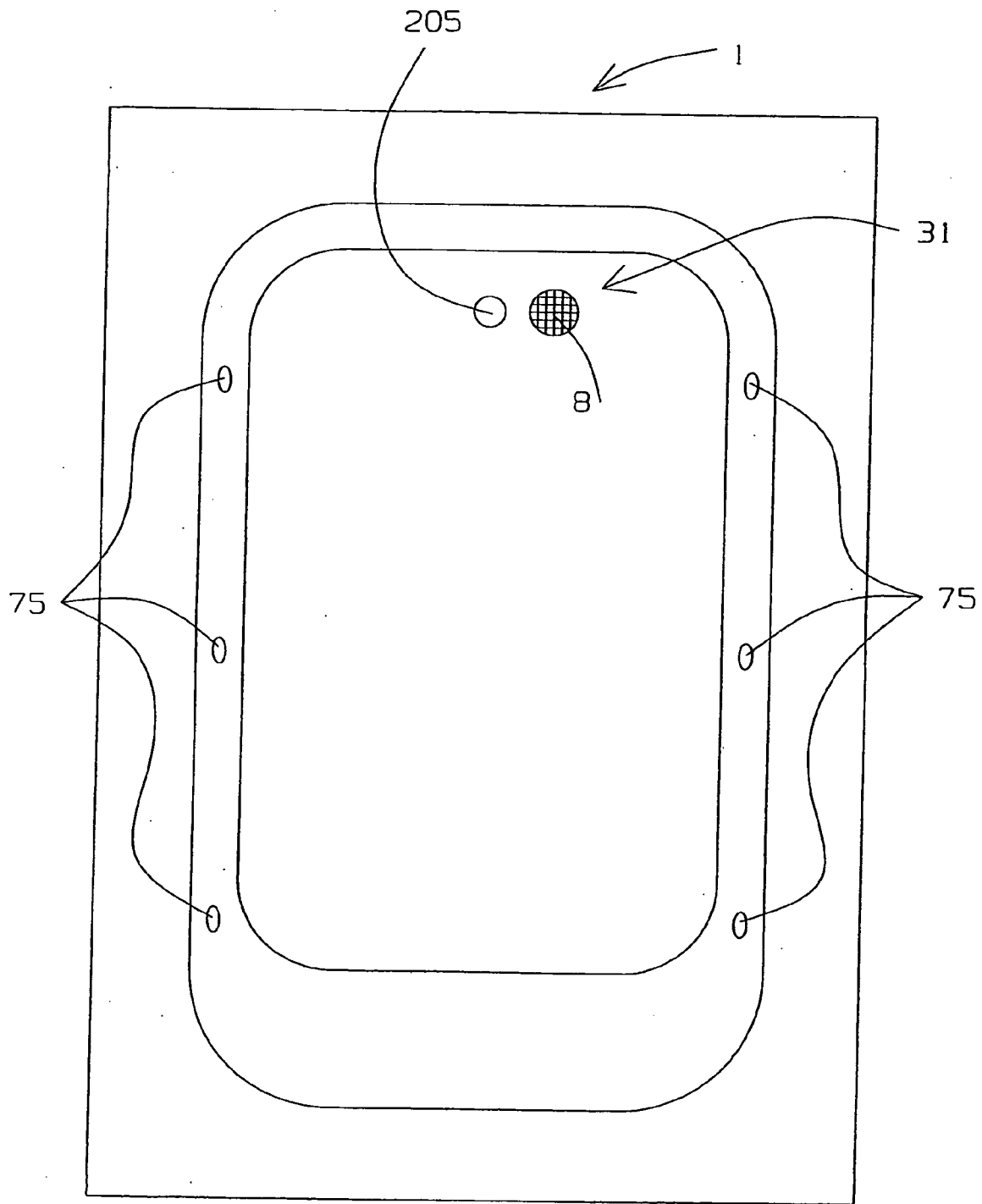

FIG. 25

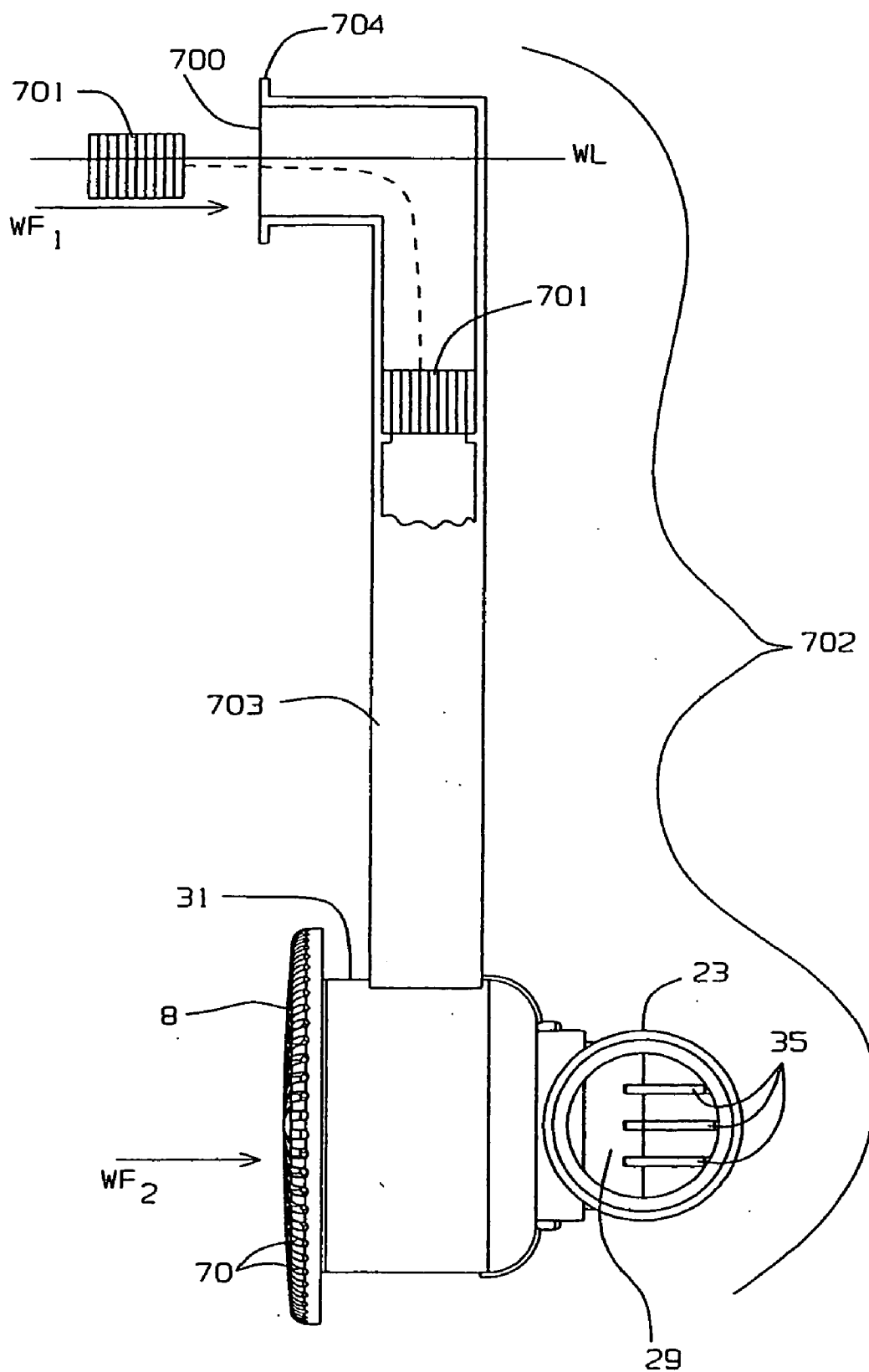

FIG. 26

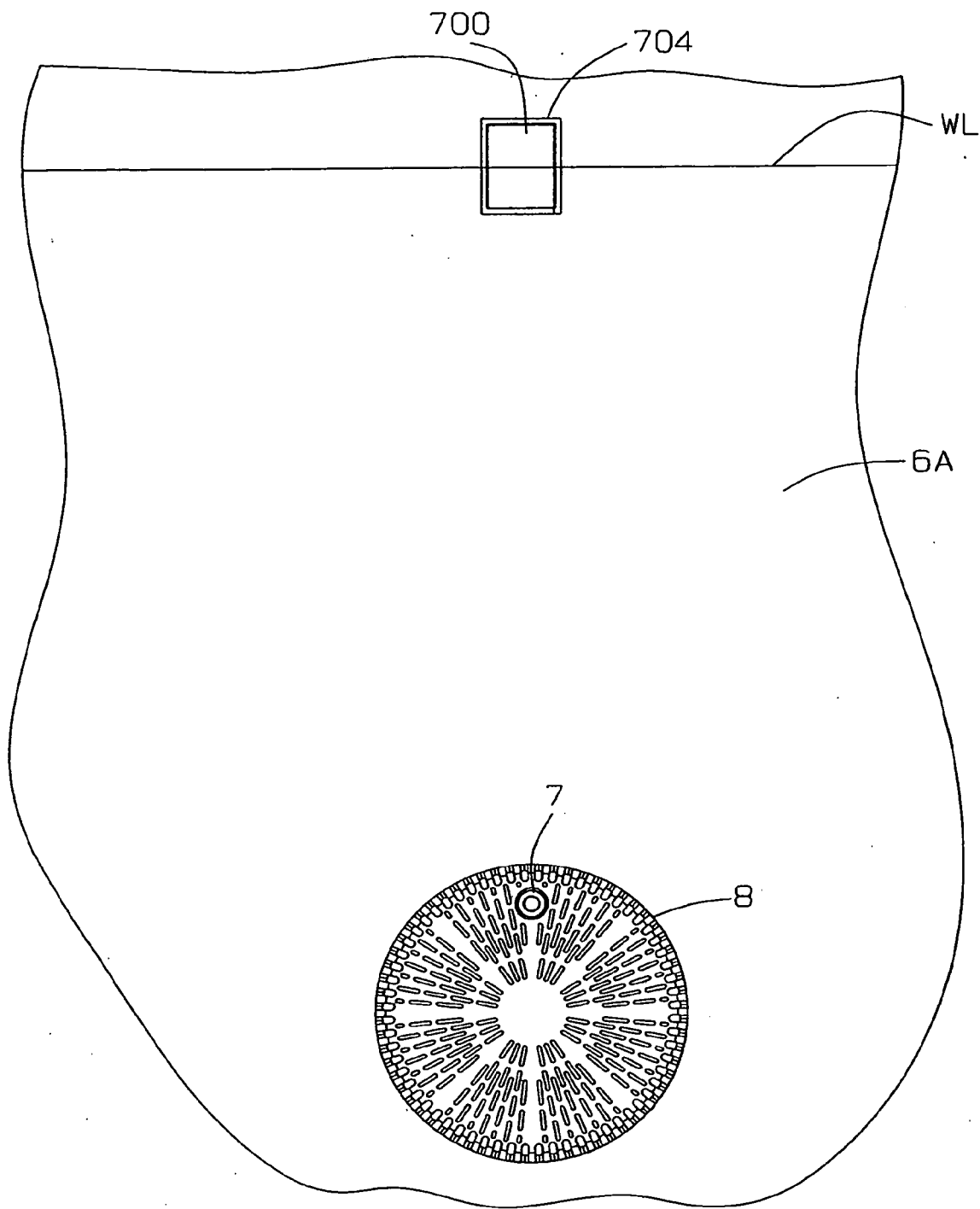

FIG. 27

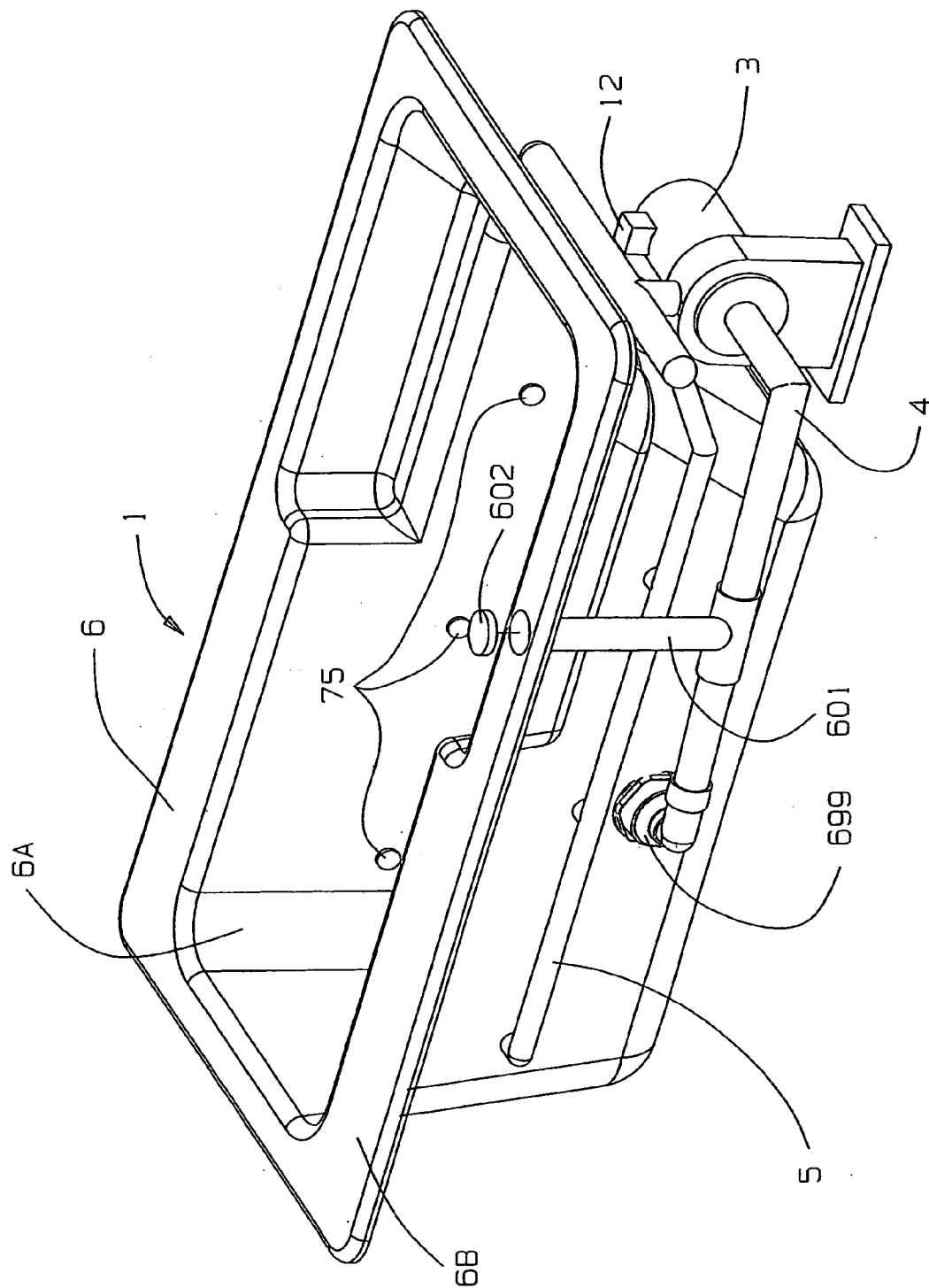

FIG. 28

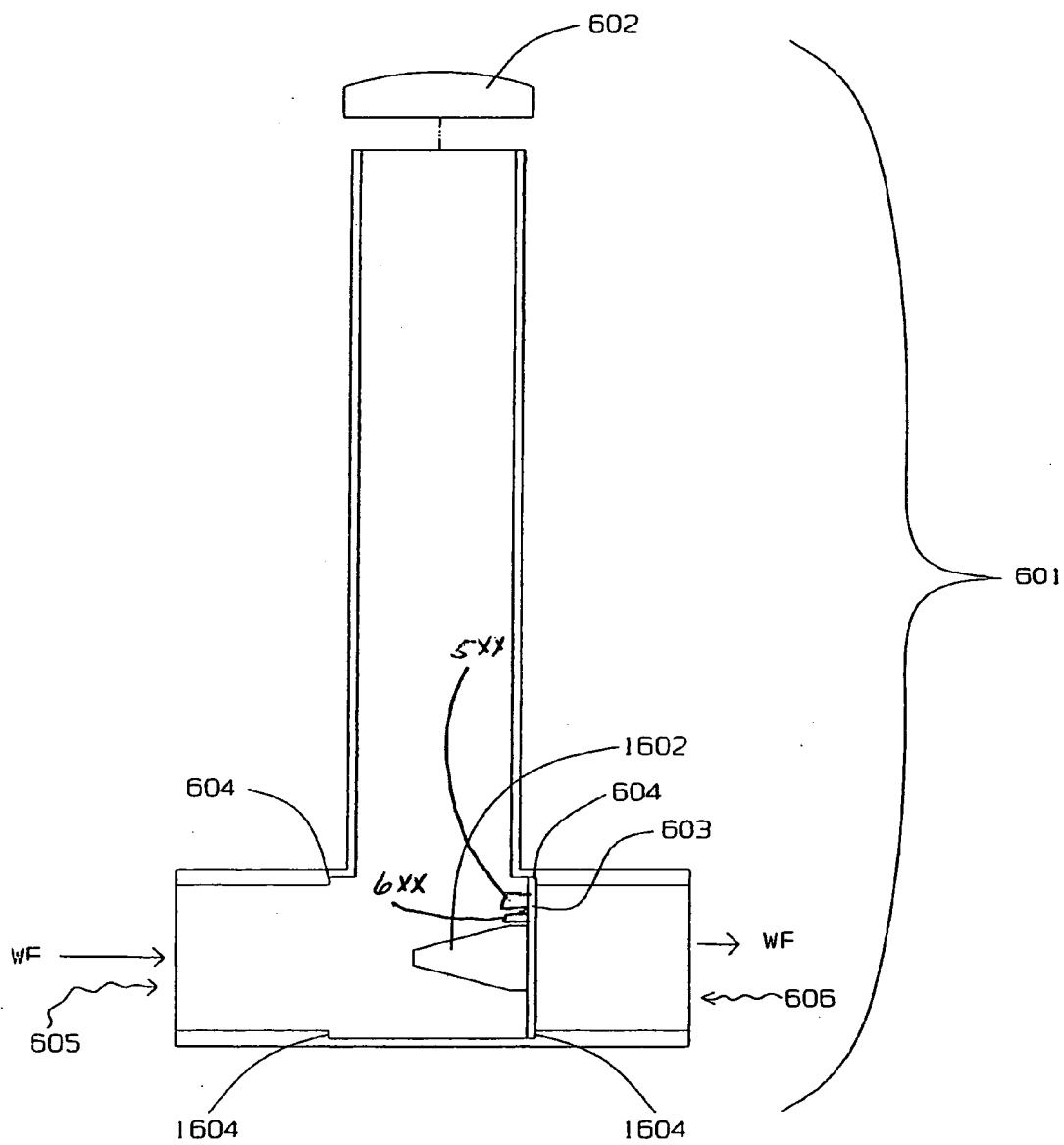
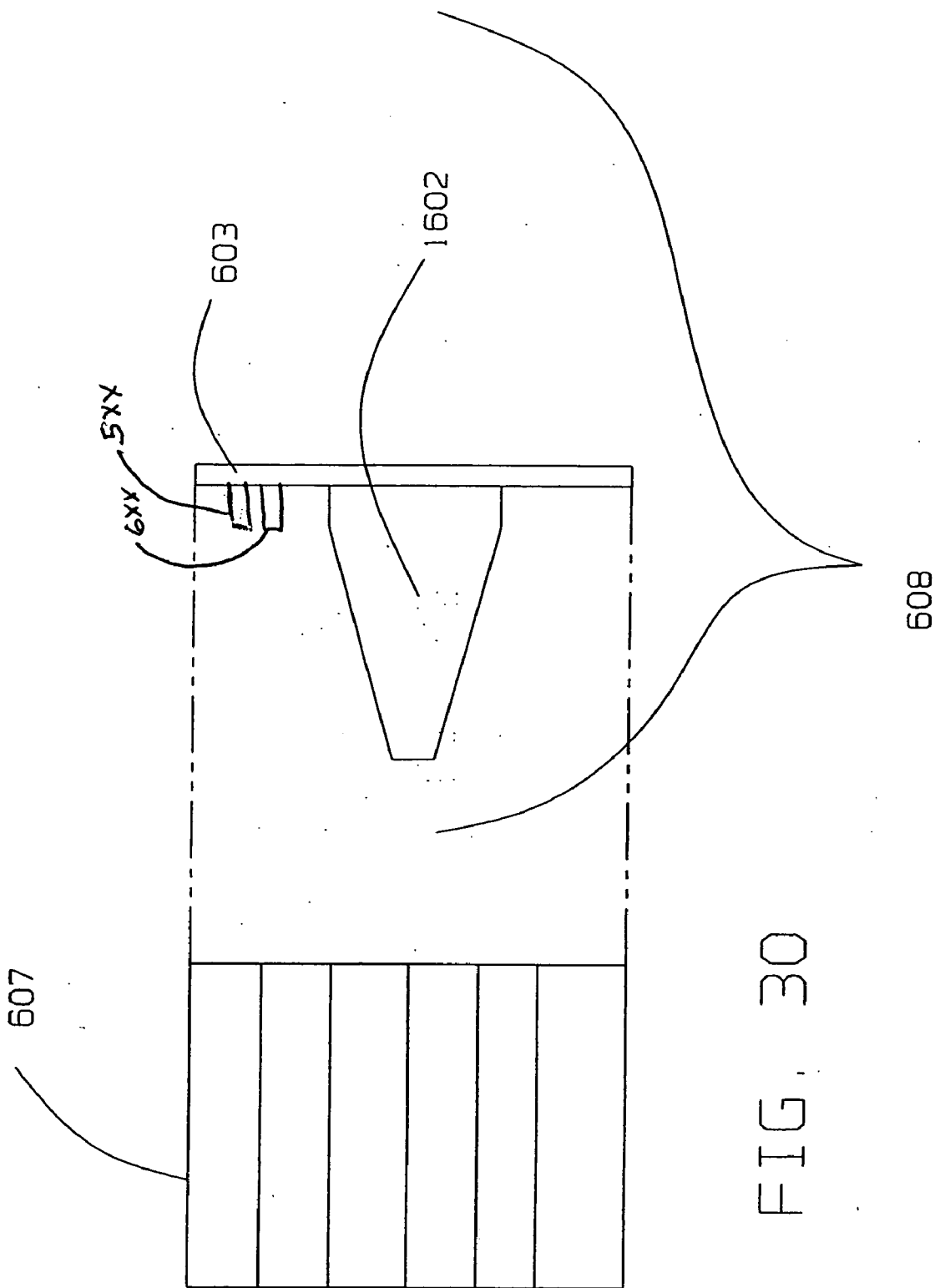

FIG. 29



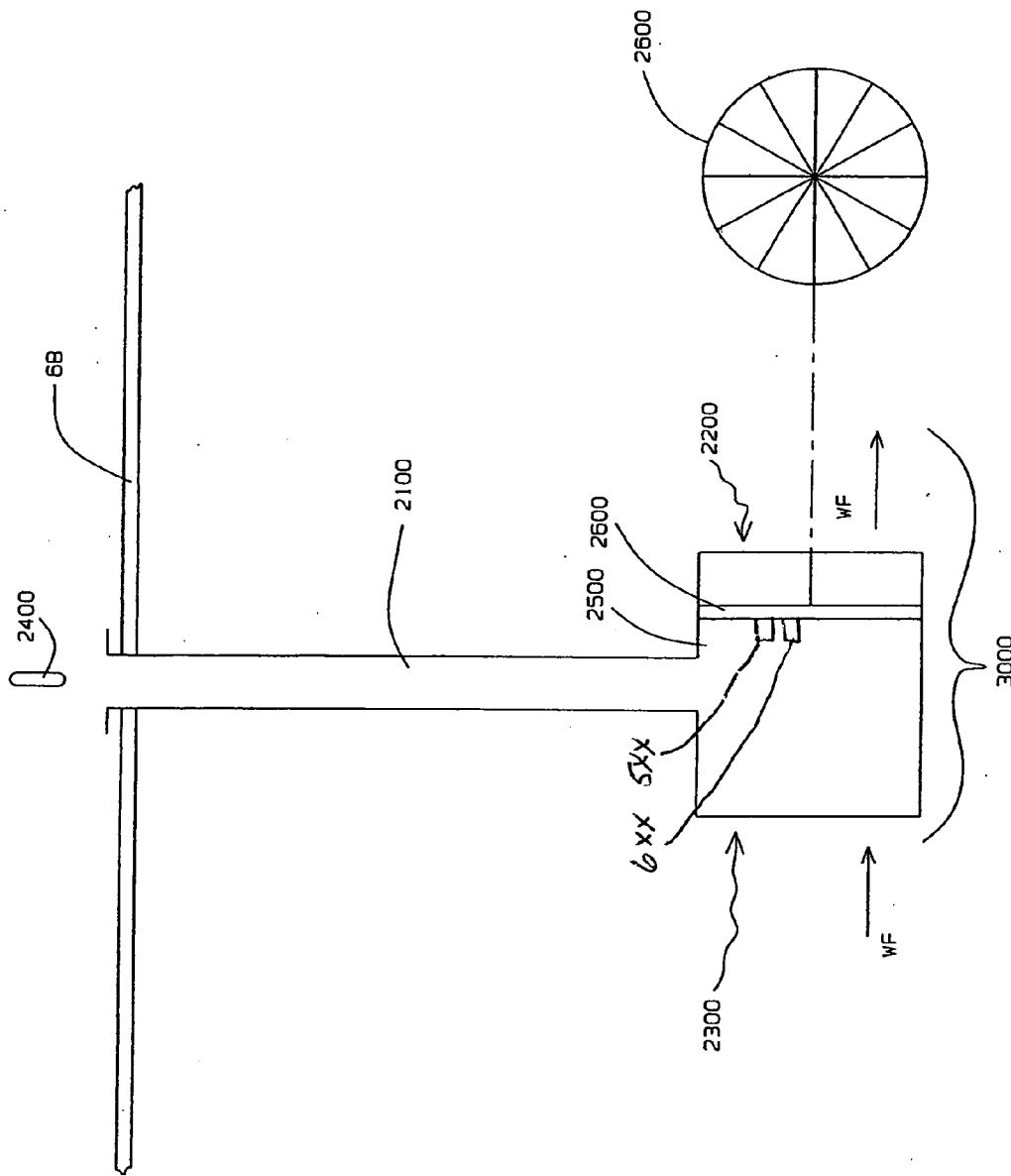

FIG. 31



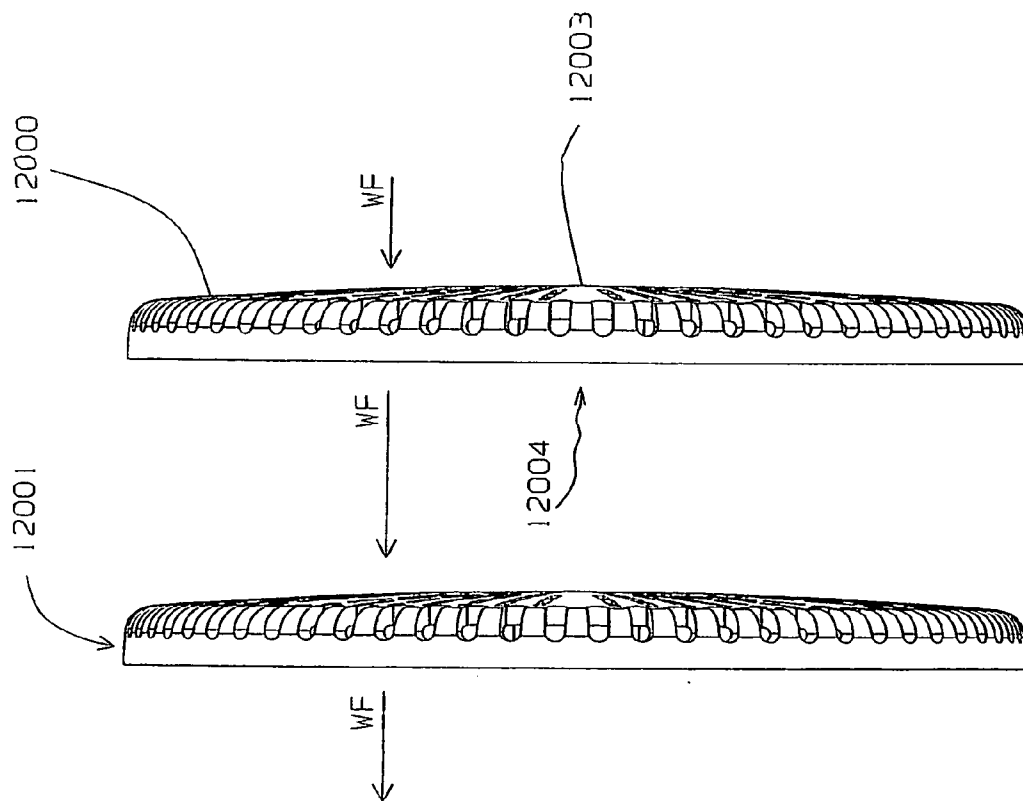

FIG. 32

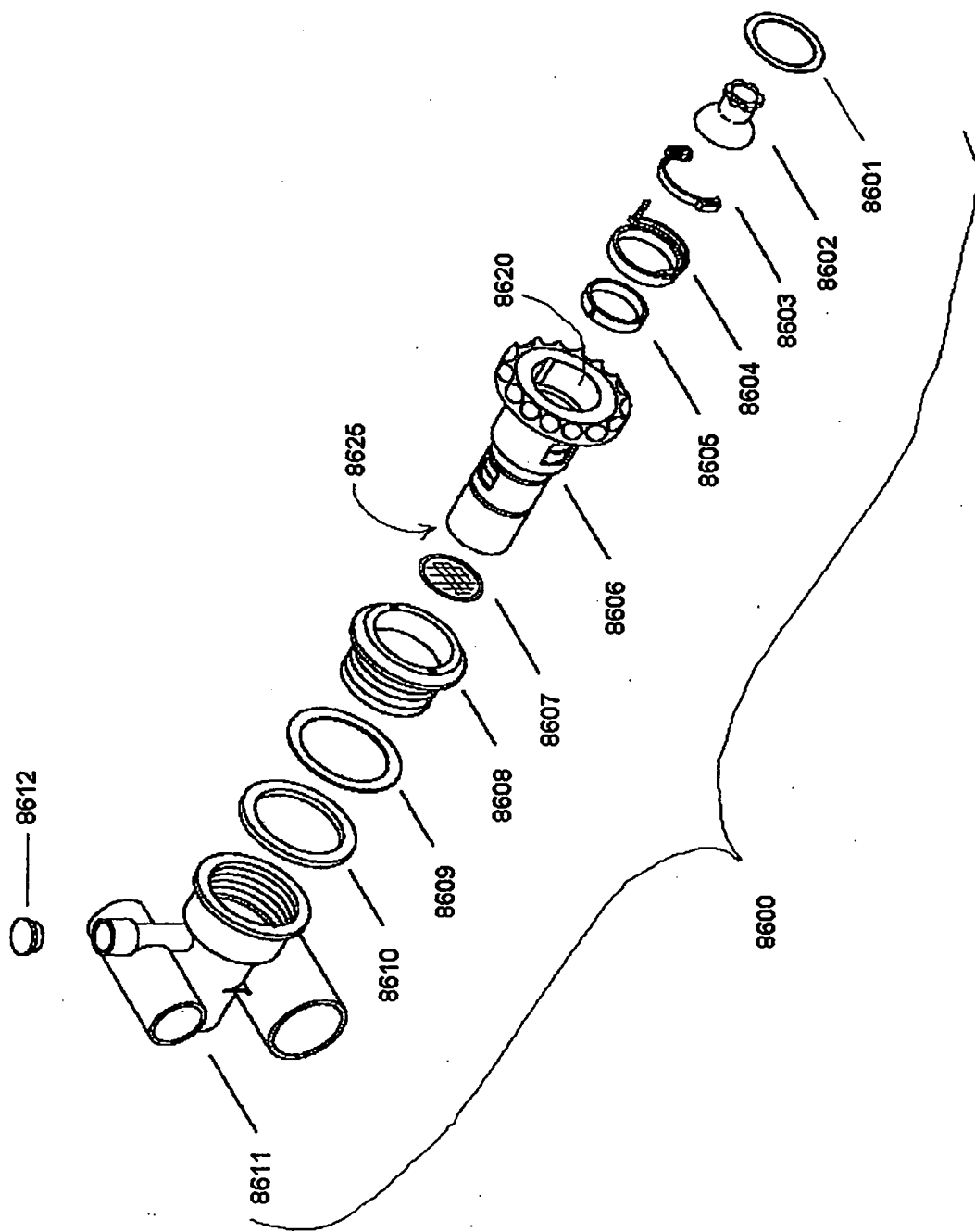

FIG. 33

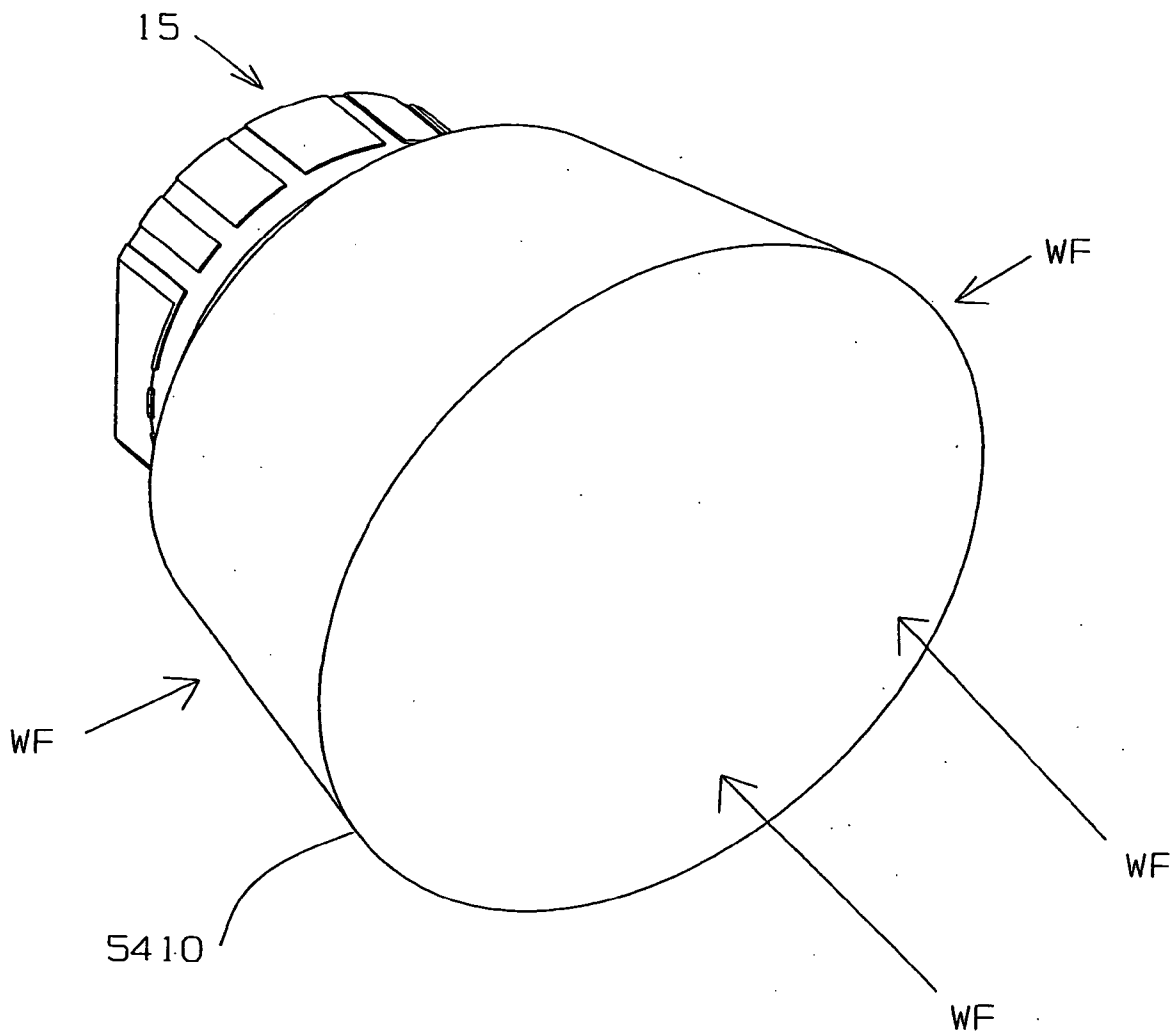

FIG. 34

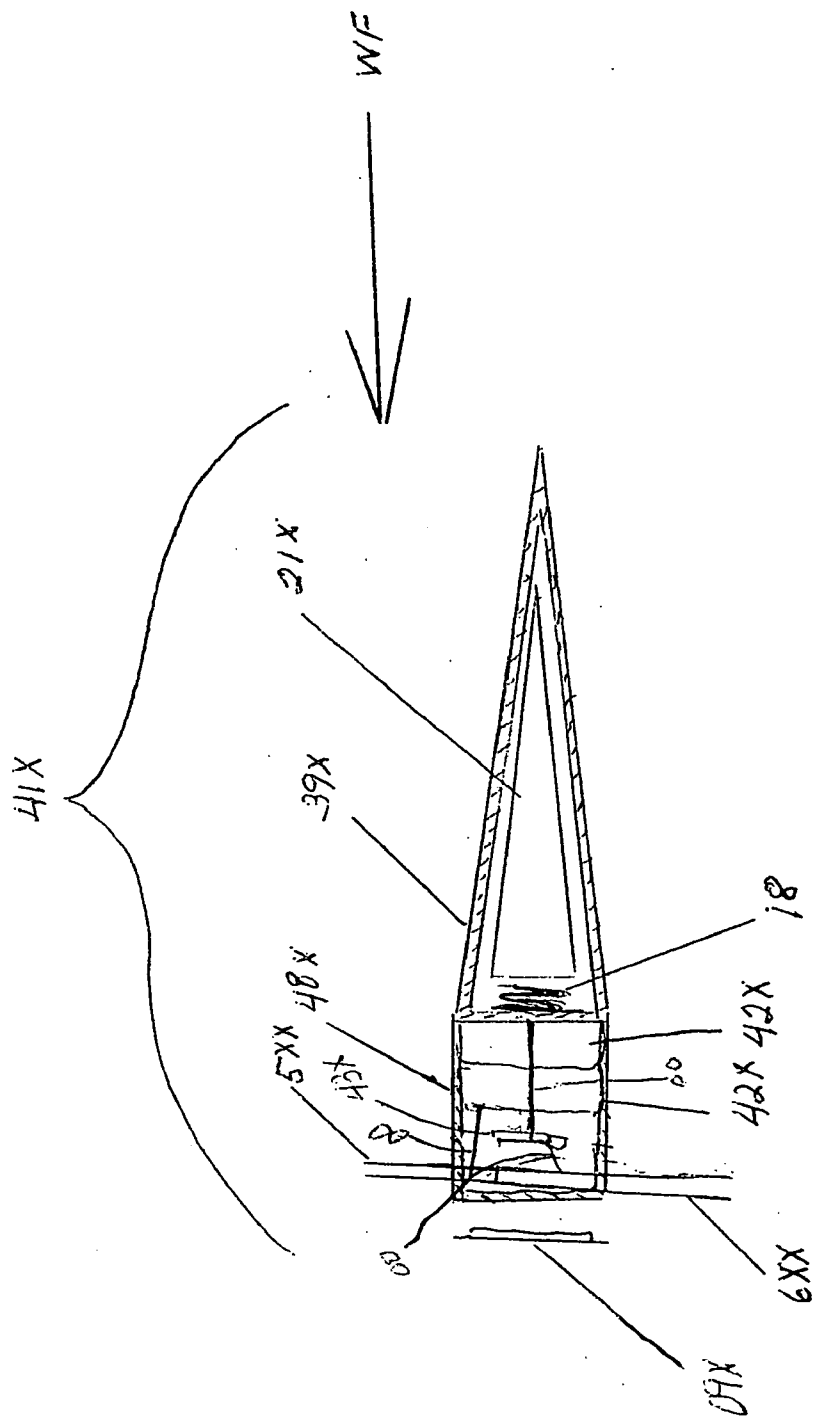

FIG. 35

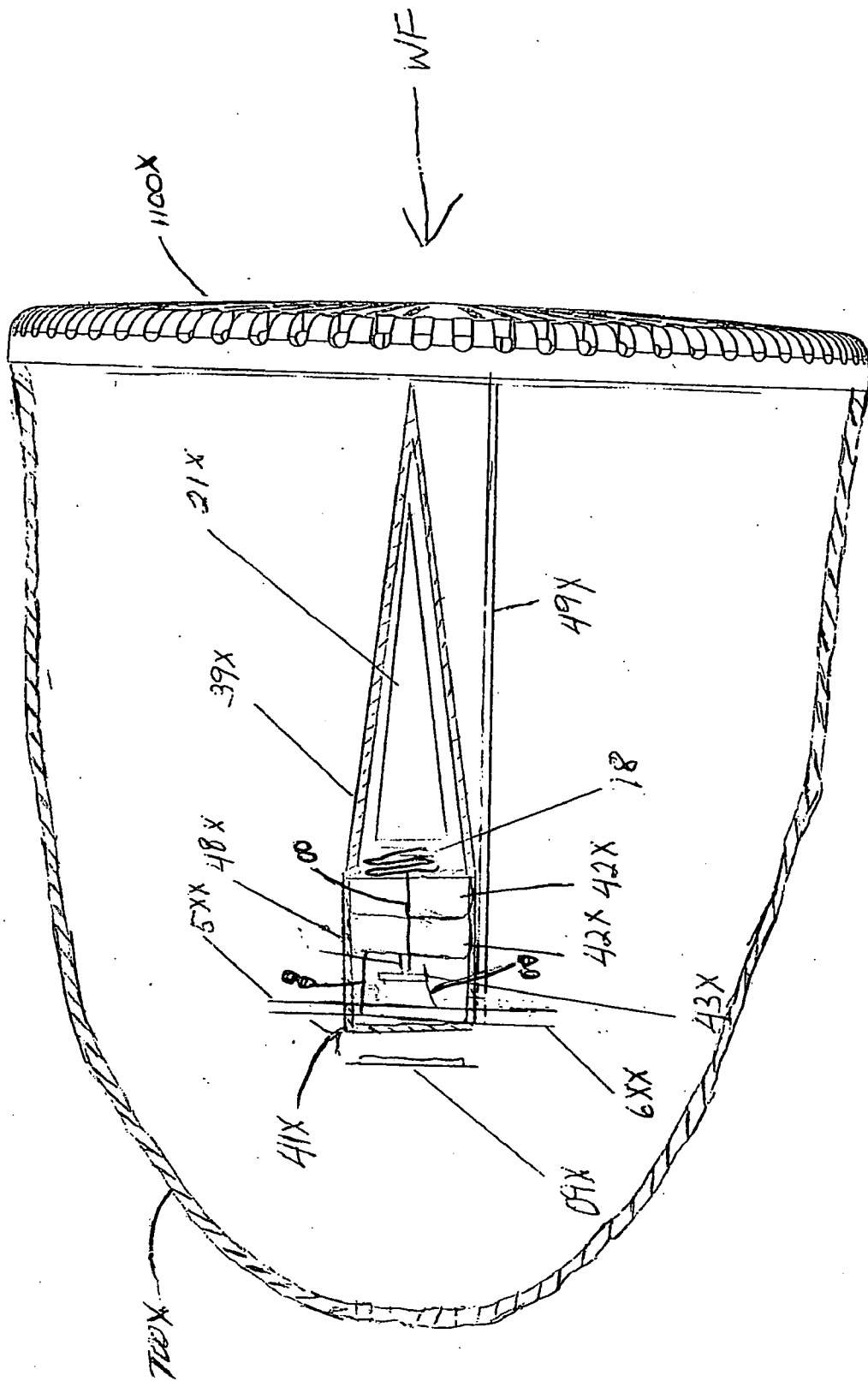

FIG. 36

## WATER SUCTION PURIFICATION DEVICE

### FIELD OF THE INVENTION

[0001] The present invention provides combining a non chemical purification device with a high water low suction device in a closed loop home or hotel whirlpool bath, hydrotherapeutic baths, and other water receptacles. The present invention can be retrofitted to any existing suction fitting for a whirlpool bathtub. The present invention relates to inhibiting bacteria growth in a whirlpool bathtub during use, and more specifically, to inhibiting bacteria growth in the closed looped plumbing system of a whirlpool bathtub after draining and/or between uses. Further, the present invention inhibits and/or prevents biofilm in a closed looped plumbing system. The present invention could also use a chemical.

### BACKGROUND OF THE INVENTION

[0002] Whirlpool-type baths have been employed to treat discomfort resulting from strained muscles, joint ailments and the like. More recently, such baths have been used increasingly as means of relaxing from the daily stresses of modern life. A therapeutic effect is derived from bubbling water and swirling jet streams that create an invigorating hydro massage of the user's body.

[0003] To create the desired whirlpool motion and hydro massage effect, a motorized water pump draws water through a suction fitting in a receptacle, such as a bathtub. The user first fills the bathtub. Then the user activates the closed loop whirlpool system. The closed looped plumbing system is considered to be all parts of a whirlpool bathtub that cannot be opened for cleaning. Thus, the jets, pump, piping system, air controls, sanitation suction device and the like and all components that cannot be opened for cleaning form the inline closed looped plumbing system of a whirlpool bath. The water travels through a piping system and back out jet fittings. Jet fittings are typically employed to inject water at a high velocity into a bathtub. Usually the jet fittings are adapted to aspirate air so that the water discharged into the receptacle is aerated to achieve the desired bubbling effect. (See e.g., U.S. Pat. No. 4,340,039 to Hibbard et al., incorporated herein by reference, and U.S. Pat. No. 6,395,167 to Mattson, Jr. et al. ("Mattson") which is incorporated herein by reference.)

[0004] Generally, whirlpool baths are designed like a normal bathtub to be drained after each use. However, debris in the form of dead skin, soap, hair and other foreign material circulates throughout the closed loop plumbing system. This debris does not completely drain and over time, it accumulates in the closed loop plumbing system. Such debris has been reported by scientists to cause a human health risk.

[0005] Because some liability issues have been raised in regards to the effects of bacteria growth in a whirlpool bathtub and particularly bacteria growth between whirlpool bathtub uses, whirlpool bathtub manufacturers are now recommending expensive and time consuming periodic flushing requirements for their whirlpool bathtubs. Bacteria are a base from which biofilm growth and the present invention also inhibits or prevents biofilm growth in a closed looped plumbing system. For instance, Installation Instructions and Operations and Maintenance Guide LAB-WP-IP-

11/02-20M-WP, published by Lasco Bathware, Inc., 8101 E. Kaiser Blvd., Anaheim, Calif. 92808, instructs a user on how to install, operate, and maintain a jetted bath properly and safely. Page 19 of Lasco's Guide under the heading "Circulating System" states:

[0006] ". . . [W]e recommend that you purge it [whirlpool] at least twice a month, or more depending upon use . . . . Fill the bath with hot water . . . . Add to the hot water, 4(6) tablespoons of low foaming detergent such as liquid Cascade or Calgonite and 24(48) oz. of liquid household bleach . . . . Turn air induction completely off. Run the bath for 5 to 10 minutes. Drain the bath completely and refill with cold water only. Run the whirlpool for 5-10 minutes. Drain the bath completely and refill with cold water only. Run the whirlpool for 5 to 10 minutes, then drain bath completely."

[0007] On its website at [www.sanijet.info/faq.htm](http://www.sanijet.info/faq.htm), Sanijet Corporation, 1462 S. Beltline Road, Coppell, Tex. 75019, publishes information regarding whirlpool bath systems that consumers have a right to know. Sanijet cites Rita Moyes, Ph.D., Director of the Microbiology Laboratory, Texas A&M University, who tested over 40 whirlpool bath water samples from homes and hotels across the country, as having determined that all of the samples tested positive for at least one type of (and frequently more) pathogenic bacteria or fungus.

[0008] "Since December 1998, I have been conducting tests on the microbial content of whirlpool bath water from piped whirlpool baths in homes and hotels across the nation. These tests were conducted on aseptically collected samples sent to me in sterile containers, which were then subjected to standardized laboratory tests to assess relative bacterial numbers. All piped whirlpool bathtubs present identical dangers of microbial propagation because the biofilms, which constitute the bacterial environment, collect and remain on the interior of the piping. All tub samples tested contained microorganisms including enteric organisms, fungi, *Pseudomonas* sp., *Legionella* sp., and *Staphylococcus aureus*. The enteric bacteria cause 30-35% of all septicemias (blood infections), >70% of urinary tract infections, and many intestinal infections. *Pseudomonas aeruginosa* has been implicated in infections of the respiratory tract, bum wounds, urinary tract, ear, and eye. It can also cause *bacteremia*, *endocarditis*, and *gastroenteritis*. All *Pseudomonas* sp. can cause opportunistic infections in immunocompromised patients. *Legionella* is the causative agent of *Legionnaires'* disease (with a 20% mortality rate) and Pontiac fever. *Staphylococcus aureus* causes a number of cutaneous infections including impetigo, folliculitis, furuncles, carbuncles, and wound infections. *S. Aureus* also release a toxin, which is responsible for scalded skin syndrome, toxic shock syndrome, and food poisoning. *S. aureus* is also an etiological agent for bacteremia, endocarditis, pneumonia, empyema (pus in the plural cavity), osteomyelitis, and septic arthritis. This was just a preliminary study and I tested for only a few types of organisms but it should be obvious that the presence of these microorganisms illustrate the potential health risk the bather exposes themselves to upon each entry into the tub."

[0009] “Any piped system will propagate harmful microbes which can and do cause sickness and death in humans.”

[0010] “Due to the presence of pathogenic and potentially pathogenic organisms, education of the public on the hazards of piped whirlpool bathtubs use should become a priority.”

[0011] Rita Moyes, Ph.D., as cited in *Sanijet Frequently Asked Questions, Question No. 6 regarding evidence that shows piped whirlpool circulation systems promote the growth of infectious microorganisms* (visited Jun. 23, 2003) <<http://www.sanijet.cinfo/faq.htm>>.

[0012] Sanijet cites Dr. Jon R. Geiger, Ph.D., Group Leader, Microbiology, Olin Research Center Cheshire, Conn., as stating:

[0013] “I suspect that [air induction systems] may be a reservoir for all kinds of organisms . . . organics provide food and shelter for microorganisms, including possible pathogens.”

[0014] Jon R. Geiger, Ph.D., as cited in *Sanijet Frequently Asked Questions, Question No. 12 regarding the identification of the Legionella organism in piped whirlpool baths* (visited Jun. 23, 2003) <<http://www.sanijet.cinfo/faq.htm>>.

[0015] Sanijet cites William J. Costerton, Ph.D., microbiologist, Director of the Center for Biofilm Engineering (CBE), Montana State University, as stating:

[0016] “The CBE is the premier research institution for the study of the slimy surface aggregations of bacteria called biofilms. I coined the term ‘biofilm’ . . . in an article in *Scientific American* (February 1978), and have since published more than 400 research papers on this topic.”

[0017] William J. Costerton, Ph.D., as cited in *Sanijet Frequently Asked Questions, Question No. 6 regarding evidence that shows piped whirlpool circulation systems promote the growth of infectious microorganisms* (visited Jun. 23, 2003) <<http://www.sanijet.cinfo/faq.htm>>. Further, Dr. Costerton comments on a controlled study of a Jacuzzi piped whirlpool bath by a CBE research engineer:

[0018] “The data summarized in this report show, with scientific certainty, that biofilms are formed on the surfaces of the pipes that feed the jets, and that these biofilms contain very large numbers (hundreds of thousands of cells per square centimeter) of heterotrophic bacteria, including many cells of *Pseudomonas aeruginosa*. This test reconfirms the widely known fact that biofilm forms in piped systems of this nature and it will form similarly in any whirlpool tub that humans use for bathing which utilize a piped circulating system. Irrespective of how well the system drains, water adheres to the interior pipe walls and this is the initial mechanism by which the bacteria are able to attach to the surfaces and thereafter begin the process of forming biofilm. Because small particles are always entrained in bubbles, the whirlpool jets produce an aerosol that contains bacteria from these biofilms, and direct observations of this test system have shown that the aerosol contains sessile bacteria in matrix-enclosed biofilm fragments. It is therefore a scientific certainty that any person using this whirlpool bath, with the jets in operation, would be exposed to airborne biofilm fragments containing pathogenic bacteria. While it cannot be predicted with certainty which bathers will develop overt

pulmonary disease, it can be stated with scientific certainty that all bathers will have been exposed to the potentially hazardous aspiration of biofilm fragments as a result of using this whirlpool bath.”

[0019] “The chance of infection during any given bath cannot be predicted with mathematical precision because contact with, or duration of, the bacteria is a random event depending on many variables. However, it is scientifically certain that all bathers are exposed to an environment conducive to infection and—if they are bathing in the typical nude fashion and having no device filtering the air they breathe—which, of course, is the usual procedure, they are taking no precaution against infection in an environment where they are surrounded by microscopic disease causing organisms and, unbeknownst to them, they should be taking precautions.”

[0020] “Our experience in the cleaning of biofilm colonized pipes, for the re-use of these systems in laboratory experiments, indicates that a 24-hour exposure to bleach (at a sustained hypochlorite concentration of more than 2%) is necessary to kill bacteria in biofilms and to remove the biofilm matrix from these surfaces. If the matrix material is not removed, the regrowth of the biofilms is very rapid (less than 2 days), while perfectly clean surfaces will re-foul in +/-4 days. Because these effective measures would be beyond the resources of even the most fastidious spa owners, there is essentially no way to keep units designed in this way free from biofilms that constitute a real risk to human health.”

[0021] Id.

[0022] It is well-known in the art that biofilms are produced by microorganisms and consist of a sticky rigid structure of polysaccharides and other organic contaminants. This slime layer is anchored firmly to a surface and provides a protective environment in which microorganisms grow. Biofilms generally form on any surface that is exposed to non-sterile water or other liquids and is consequently found in many environmental, industrial and medical systems.

[0023] Sanijet cites Michael Nicar, Ph.D., Epidemiologist, board certified in clinical chemistry and pulmonary function testing, and credentialed in the field of human disease testing and research, as stating

[0024] “The relative risk for transmission of *Legionella* via whirlpools, is significant (*The Lancet* 347:494, 1996), even for people standing next to the whirlpools (they did not even have to get in to the water). The drain and fill whirlpools make aerosols just like the hot tub models. Thus, the transmission of disease is the same between the drain and fill and the constant filled hot tub models.”

[0025] “Physicians need to know that [whirlpool bathtubs] are a source of exposure to *Legionella* bacteria. Otherwise, an erroneous diagnosis and incorrect choice of therapy may result. . . . Delay of appropriate therapy can result in prolonged hospitalization, complications, and death . . .”

[0026] Michael Nicar, Ph.D., as cited in *Sanijet Frequently Asked Questions, Question No. 13 regarding assessments a consumer can make about the health risk of using a piped whirlpool bath* (visited Jun. 23, 2003) <<http://www.sanijet.cinfo/faq.htm>>.

[0027] Sanijet cites Dr. Christine Pasko-Kolva, Ph.D., Environmental Group Leader Perkin Elmer, Foster City, Calif., as stating:

[0028] "I think it is very important to point out that the CDC has used that test [PCR] in other outbreaks in Colorado of a hot tub where the disinfectant level was at the appropriate concentration, yet there was still an outbreak. These protozoans [with *Legionella* engulfed in them] can insist, and once they insist they can be resistant to concentrations up to 50 ppm of free chlorine . . . after exposure to 50 ppm . . . amoeba cysts were able to exit and release the *Legionella*. So disinfection alone is not going to solve the problem. We do know that the infectious dose [of *Legionella*] is considerably low because it's an intracellular infection . . .

[0029] Christine Pasko-Kolva, Ph.D., as cited in *Sanijet Frequently Asked Questions, Question No. 12 regarding the identification of the Legionella organism in piped whirlpool baths* (visited Jun. 23, 2003) <<http://www.sanijet.cinfo/faq.htm>>.

[0030] Sanijet cites E. Tredget, MD et al., "Epidemiology of Infections with *Pseudomonas aeruginosa* in Burn Patients: The Role of Hydrotherapy", *Clinical Infectious Diseases* 1992, as stating:

[0031] "Outbreak of *pseudomonas* infection, including multiple deaths, in burn treatment unit was attributed to hydrotherapy tubs (piped whirlpool baths) despite rigorous disinfectant procedures after each use, leading to the discontinuance of hydrotherapy."

[0032] "*P. Aeruginosa* is a opportunistic gram-negative pathogen that thrives in an aquatic environment and has been identified as the cause of numerous outbreaks of skin infection transmitted to unburned patients and health care workers by medical equipment used for hydrotherapy. Because the organism was recovered from hydrotherapy equipment, this form of treatment was stopped and the strain of *P. aeruginosa* associated with the epidemic was eradicated . . . This outbreak occurred despite weekly surveillance cultures of this equipment and the use of standardized protocols for its disinfections between uses."

[0033] E. Tredget, MD et al., as cited in *Sanijet Frequently Asked Questions, Question No. 6 regarding evidence that shows piped whirlpool circulation systems promote the growth of infectious microorganisms* (visited Jun. 23, 2003) <<http://www.sanijet.cinfo/faq.htm>>.

[0034] In addition, Sanijet cites Canadian Infection Control Guidelines for Long-Term Care Facilities, which emphasize the necessity of having complete component and system disinfection:

[0035] "Single-use recirculating hydrotherapy equipment, such as bath tubs, century tubs, hubbard tanks and whirlpools, must be drained after each resident use. *Pseudomonades*, *legionellae* and other bacteria thrive in the warm, moist, dark environment of the internal plumbing of these units. Given the opportunity, they may form a semi-permanent biofilm, which can provide a never-ending reservoir of bacteria within the system. It is necessary to disinfect all

components of the unit, including the basin, the internal plumbing and the lift chair with a disinfectant-detergent . . . Prior to the first use of the day, it is necessary to disinfect the entire system . . . as *organisms may have survived the disinfection process of the previous day and multiplied.*" (emphasis added.)

[0036] Canadian Infection Control Guidelines for Long-Term Care Facilities, Rev. 1993 (pp. 8-9) as cited in *Sanijet Frequently Asked Questions, Question No. 6 regarding evidence that shows piped whirlpool circulation systems promote the growth of infectious microorganisms* (visited Jun. 23, 2003) <<http://www.sanijet.cinfo/faq.htm>>.

[0037] Therefore, a sanitation system designed for whirlpool baths is desirable. The present invention addresses these concerns and inhibits harmful bacteria growth between bathtub uses. The present invention additionally inhibits and/or prevents biofilm in a closed looped plumbing system using a very low amount of chemical or no chemical at all. Specifically, the present invention provides for a sanitation system, which not only inhibits bacteria growth during whirlpool bathtub activation, but also more importantly, inhibits bacteria growth between whirlpool bathtub activation cycles. The present invention teaches the inhibiting of bacteria in a whirlpool bathtub's closed looped plumbing system both during and/or between whirlpool bathtub usages.

[0038] In practice, copper and silver metals are made into an alloy from which electrodes are cast. When the electrodes are placed in a whirlpool bathtub suction fitting and a small current of electricity is allowed to flow between the two electrodes, copper and silver ions are released into water from the positive electrode (anode). The ions are swept into the closed loop plumbing system of the whirlpool bathtub by the rapid flow of water and become part of the closed loop plumbing system's water and the tubs water. These ions are completely safe to use and provide a residual disinfectant and algacide avidity throughout the whirlpool bathtub to inhibit bacteria and bio film. With just using silver and not the copper or some other bacteria inhibiting alloy, bacteria and biofilm are inhibited. The current invention also has a current limiting device to supply the proper current to the electrodes. The current invention could also have numerous additional features such as a fragrance dispenser, a light source that inhibits bacteria and sound source that inhibits bacteria or other features. All components that make up the purification device can be arranged in any configuration.

[0039] The present invention uses an electrolytic generator consisting of a positively charged anode consisting of the metal(s) to be ionized and a negatively charged cathode. The electrodes are housed in a high water low suction housing through which the water to be purified flows. The anode and cathode are connected to a DC power source of a few volts and a weak electrical current flows between them. This causes the following electrode reactions to occur:



[0040] The metal ion concentration can be precisely controlled by varying the flow rate of the water through the chamber and varying the electrical current to the electrodes. The rate at which metal ions are produced by the electrode is directly proportional to the applied current to the elec-



trodes. The rate at which the ions are removed from the cell is directly proportional to the water flow rate through the cell. The concentration of metal ions in the effluent from the cell is given by:

$$C = k i / F, \tag{10}$$

[0041] where C=Concentration (in ppb),

[0042] i=current

[0043] F=Water flow rate,

[0044] and k=constant.

[0045] To further aid in inhibiting bacteria a small amount of a chemical could be added to the system via a chemical chamber. Silver/copper ion systems allow an 80 percent reduction in the use of bromine or chlorine, extremely harsh chemicals, without any drop in anti-bacterial action. In addition to the marked drop in chlorine and its irritating effects to nose and mucous membranes—including extreme reactions in those allergic to chlorine or bromine—is the advantage that copper and silver ions do not evaporate. Over the heat of summer or inactivity during winter, the anti-bacterial action of these two metals is never lost as is the case with chlorine. These metals seldom leave the water unprotected from bacteria. Other metal alloys such as zinc and the like could be used.

[0046] The recommended sanitizer level will vary depending on the sanitizer used. For chlorine-treated commercial pools, the ideal range is 2 to 4 ppm of available chlorine. Bromine levels should be kept slightly higher at 4 to 6 ppm. However, pools and spas are seldom filled with water, seldom drained and they are usually subjected to a harsher environment than whirlpool bathtubs. The level of chemicals needed in a fill and drain whirlpool bathtub is less than is needed in an outdoor pool. Whirlpool bathtubs need less than about 1 part per million of bromine to inhibit bacteria in a closed loop system.

[0047] Why would chlorine or possibly other chemicals be a problem in a whirlpool bathtub when it has been used for so long in spas and swimming pools? When chlorine and possibly other chemicals escape from water it is diluted in the available air space. The smaller the air volume such as found in bathrooms, the greater the concentration of airborne chloramines (the nasty product of water chlorination). The concentration of chlorine in the air is gradual, being highest at the water surface and least at the greatest distance from the surface. Chlorine concentration is also governed by the movement of air across the water surface (the greater the movement, the less the concentration of chloramines assuming that removed air is replaced by fresh air

[0048] This results in accumulated concentrations of Trihalomethanes (THMs) just above the water surface, that is, in the air that water vessel users continually breathe. Chlorine reacts with bodily proteins to form chloramines; the most volatile and prevalent in the air above swimming pools is nitrogen Trichloride (NCl3). Admittedly, one bath in such a vessel might not produce any health problems in a bather, but frequent users such as competitive age-group, school and college suffer extended periods of exaggerated breathing in the hyper-chlorinated micro atmosphere.

[0049] “Chlorine readily combines with chemicals dissolved in water, microorganisms, small animals, plant material, tastes, odors, and colors. These components “use up” chlorine and comprise the chlorine demand of the treatment system. It is important to add sufficient chlorine to the water to meet the chlorine demand and provide residual disinfection. Chlorine and ionization. As an alternative disinfectant to sole chlorination, electrolytically generated copper and silver ions (400 and 40 micrograms/L copper and silver, respectively) with and without free chlorine (0.3 mg/L) was evaluated over a period of 4 weeks in indoor and outdoor water systems (100 L tap water with natural body flora and urine). Numbers of total coliform, pseudomonas, and staphylococci were all less than drinking water standards in systems treated with copper: silver and free chlorine and systems treated with free chlorine alone (1.0 mg/L). It was concluded that the addition of electrolytic copper and silver to water systems may allow the concentration of free chlorine to be reduced while still providing comparable sanitary quality of the water “(Yahya et al. 1990).

[0050] Therefore, the present invention only needs about 80% of this amount of bromine or about 80% most other antimicrobial chemicals to inhibit bacteria in a closed loop system. Nationally the amount of chlorine mixed with drinking water is about 12 part per million. Some areas have as low as ¼ part per million. Well water is not normally treated with antimicrobial chemicals. In areas that use normal tap water with about ¼ parts per million or less of chlorine the present invention does not require any extra induced chemical to inhibit bacteria growth in a whirlpool bathtub. For users that fill their whirlpool bathtub from a well or other means where the water is not chemically treated, a chemical dispenser could be added to the system. Mattson shows prior art of having a chemical dispenser located inside a suction device. The current invention if used without treated water could have a chemical dispenser. However, the current inventions chemical chamber would be much more efficient. Only 80% of the amount of chemical would be needed to disinfect the system. Suction fittings are very small and therefore the chemical chamber inside a suction fitting needs to be small. Most chemical chambers in a small suction device can only hold enough chemical to sanitize about 30-90 bath cycles before needing replacement or replenishment. The current invention’s chemical chamber with the same amount of chemical housed therein as the Mattson’s prior art chemical chambers would last for over 1 to 365 or more bath cycles before needing replacement or replenishment. Therefore, the chemical chamber would not need to be replaced or replenished but once a year. Additionally, there is a sufficient amount of copper and/or silver to last for a period of over 1 to 365 bath cycles before needing replacement or replenishment. Additionally, the purification device operates when the whirlpool bathtub is activated. However, some users wish to use the whirlpool bath as a tub and not use the system. The chemical would then leach out of the chamber when contacted with water. The current invention could also use a battery to active the electrodes if a normal bath were taken without activating the whirlpool bathtub system.

[0051] Therefore, the current invention is a major breakthrough in inhibiting bacteria and biofilm one replaces the purification component only about every 365 bath cycles depending upon use. The present invention incorporates electrodes made of an alloy that has antimicrobial properties

into a suction housing of a below the water line suction device. Placing a purification device with electrodes into a suction device for a whirlpool bathtub presents a whole range of engineering issues that need to be solved. It also has to be effective with very high water flow rate (gallons per minute, pressure), and it cannot restrict the whirlpool bathtub's jet performance. Due to the extremely high flow rates, it also has to be engineered for safe use. Additionally, it was important to engineer a system whereby it insures that every bath cycle had the proper amount of antimicrobial additives to inhibit bacteria growth. In other words, the whirlpool bathtub would not run without the purification device operating. If the whirlpool bathtub were able to be run without the purification device operating for any period of time, there could be a nominal to excessive amount of bacteria built up in the whirlpool bathtub closed looped plumbing system between usages.

[0052] A few years ago, whirlpool bathtubs typically utilized pumps that pumped over 40 gallons per minute (gpm) of water. Whirlpool bathtubs today typically utilize pumps that pump about 70 to 200 gpm. This creates a tremendous amount of suction force through a sanitation suction device. In the disclosed embodiment of the present invention, the purification device was engineered to be small so as not to restrict or decrease water flow or jet performance. However, it needed to be large enough to supply sufficient antimicrobial to last over a period of cycles, e.g. 365 or more, and it had to be designed to not only limit bacteria growth in the bath water in the tub during use, but also to inhibit bacteria growth in the closed looped plumbing system between usages. The purification device of the present invention fits into the inlet orifice of a suction housing. The purification system is very compact. This reduces restriction to the inlet orifice and allows for higher pressure out of the whirlpool bathtub jets. An alternative embodiment has the purification device positioned away from the inlet orifice so there is no need to increase the diameter of the inlet orifice. This alternate embodiment also does not restrict pressure flow out of the jets.

[0053] The disclosed embodiment utilizes direct water flow electrodes. High pressure water flow (about 70 gpm or higher) surrounds and passes by the electrodes. Current is past between the electrodes releasing ions that are swept into the closed loop plumbing system of the whirlpool bathtub by the rapid water flow and become part of the closed loop plumbing system's water and the tubs water. The ions also release when water is present and not just when water is flowing past the electrodes. An alternate embodiment of the current invention could have the addition of an antimicrobial dispenser as found in Mattson's prior art.

[0054] Another problem that exists in adding a purification device to a suction device for a whirlpool bathtub is compliance with the plumbing standards. Whirlpool baths must meet stringent drain down standard requirements set up by the American Society of Mechanical Engineers (ASME). The standard code that governs whirlpool baths is entitled "Whirlpool Bath Appliances" (ASME A112.19.7M 1995). Section 5 of this standard, incorporated herein by reference, covers water retention and provides: "whirlpool bath appliances shall be of such design as to prevent retention of water in excess of 44 ml. (1½ fl oz) for each jet and suction filter."

Therefore, a sanitation suction device for a whirlpool bathtub must allow for the whirlpool bath to meet the drain down requirements set forth by the plumbing standards.

[0055] The average whirlpool bath has a six-jet system and has one suction fitting. In order to meet code, a six-jet/one suction system configuration may only retain 10½ ounces of water in the complete whirlpool bath system after draining. Most quality whirlpool baths, however, retain less than 4 ounces of water in the whirlpool bath system after draining. Therefore, the sanitation suction device part of the system cannot retain over 6½ ounces of water, because the total water retention would then exceed 10½ ounces. A whirlpool bath having more than six jets, e.g. a 15-jet system, is allowed to retain more water. However, systems having more jets must still meet an appropriate plumbing standard. In a 15-jet/one suction system configuration, the complete system cannot retain over 24 ounces of water. The current inventions purification system retains little water if any.

[0056] Another alternate embodiment of the current invention further comprises a filter to inhibit large debris from entering the closed loop plumbing system of a whirlpool bathtub. The preferred embodiment of the current invention has a sock or cone shaped filter. This filter is shown by way of example and not limitation. Other shaped filters could be used. The filter is similar to a white nylon sock. Such a filter for use in a whirlpool bathtub, spa or swimming pool is not known in prior art. As debris builds up in the sock shape from the debris in the tub being drawn through it, the sock stretches. As the sock stretches the pore openings in the filter expand. The filter is just a means to help control larger debris such a hair and the like from entering the closed loop system and becoming entangled in a pumps impeller. Once debris such as hair becomes trapped in the pumps impeller the pump would need to be taken apart to release the trapped hair. The limiting of debris in the closed looped plumbing system also is thought to limit the food source for bacteria growth. The purification device is the only thing that inhibits bacteria, but it is thought that if the filter is used, the filter allows less antimicrobial to be used to inhibit bacteria. The filter therefore, should not clog for at least 360 bath cycles from normal bathtub debris. The filter additionally is unique in that it never will hold more than 10 grams of debris before needing replacement.

[0057] The current invention provides many safety features to prevent body entrapment and broken bones. The current invention has a safety cavitation port located on the wall of the housing. If the current invention is run without the faceplate attached and a bather were to put any body part near the exposed sanitation device's housing opening, ambient air is drawn into the current invention's housing and directly into the pump of the whirlpool bathtub. This happens nearly instantaneously and the pump cavitates (draws more air than water), and the suction force is inhibited before the bather is harmed.

[0058] The current invention also provides a safety flapper. When the replaceable antimicrobial chamber is in place, the safety flapper is in an open mode. If the replaceable antimicrobial chamber is removed, the safety flapper descends into a closed mode, and covers the inlet orifice of the sanitation suction device elbow, or the point where the antimicrobial chamber is inserted into the sanitation device

elbow. The safety flapper blocks the water to the pump thereby stopping the tremendous sucking action. Therefore, with the current invention, there is no way to run the whirlpool bathtub and potentially suck hair or body parts against or into the inlet orifice of the elbow of the current invention's housing. While the present invention provides a safety flapper to block the inlet orifice, other mechanisms could be used.

[0059] The current invention also has a safety screen located behind the safety flapper to prevent a child from getting a limb entrapped in the sanitation suction device if the whirlpool bathtub were drained and the faceplate and purification device is missing. There is no way a bather could get his/her hair entrapped in this safety screen if the whirlpool bathtub were in operation because the safety flapper covers this safety screen if the purification device is absent. As stated above, the safety flapper descends into a closed mode, and covers the inlet orifice of the suction device elbow if the replaceable purification device is removed.

[0060] It is important that a bather cannot operate the current invention when the purification devices' antimicrobial metals have been spent. Therefore, the present invention provides a means to determine when the antimicrobial metals are spent. Many means could be used but one way is to provide a simple counter that counts each time the whirlpool bathtub is activated.

[0061] To deliver the low volt electrical current to the electrodes there is a wire that attaches to the electrode through the suction fitting. This wire runs to a power supply and could have a step down transformer or an AC/DC converter. An alternative embodiment of the current invention has the purification device attached to the faceplate for insertion into a suction housing. The electrical wire could be configured in a way to extend to the electrodes using this combination. Additionally, the present invention could also use batteries to charge the electrode. The batteries could be of the type that continually charges the electrodes or could have a means that provides that the battery only works when it senses water in the tub. There are various other ways to send a charge to the electrodes and they all would fall into the scope of the present invention. The current disclosed invention could also have a means to clean the electrodes. The electrodes, current limiting device, energy source and chemical chamber or any combination thereof, could also be incorporated onto an attachment member for insertion into a suction housing assembly. Any part of the suction device or purification device could also have a device that sounds an audible sound to indicate when the purification device needs replacing. The device could count bath cycles or use other methods to sound an audible sound at a predetermined time. Let's say the purification device will last for 365 days before needing replacement. The audible device could be set to sound off at the end of 365 days. Further, the present invention could additional have sound device that delivers a sound wave to inhibit bacteria growth. This sound device could use operate as sonic tooth brushes operate or other sound devices that emit a sound that inhibits bacteria formation.

[0062] The electrodes, current limiting device, energy source, optional chemical chamber and optional filter, or any combination thereof, could also be attached to a member for

insertion into a suction housing. The chemical chamber provides on means to release a chemical into water. The chemical chamber is shown by way of example and not limitation as other means to release a chemical are possible. The arrangement of any component of the current invention is shown by way of example and not limitation. As an example one embodiment of the present invention might show the energy source connected to a faceplate component, however, it could also be attached to other components of the current invention or even a component of the device the current invention is attached or installed in or on. Any component of the present invention could have various sizes and shapes. The present invention is also not limited by features shown and described herein. Numerous other features could be added to the present invention. The features could have one or more microprocessors. The present invention could have various monitors, such as monitors for temperature, water flow, pH or other monitors. It could also have a readout mechanism such as an L.E.D. or needle. The current invention could be arranged to emit a variety of different substances or combination of substances having a variety properties. The faceplate could have various means of attaching the faceplate to a suction or housing. The faceplate could have magnets or utilize a snap on configuration or be attached with a screw or any other means to a suction or housing. Also, when ever an opening is shown, such as but not limited to the opening in the chemical chamber, all openings are shown by way of example and not limitation. All openings could be in various locations and in various sizes and in various locations and could be adjustable or no adjustable.

[0063] It is preferable that the current invention operates at high water flow of over 70 gallons per minute, however it is capable of operation when water is present even is the water has no flow rate. Various component of the present invention could double as an electrode. As an example but not limitation, the chemical chamber could be designed to work as an electrode. The present invention could also be configured so the antimicrobial properties or the entire purification device operates for at least five years without needing replacement or replenishment of the antimicrobial properties.

[0064] There is no invention that combines a high water flow suction device that incorporates an ion generator that works with high velocity water flows over 70 gallons per minute except for the present disclosed invention. There is no invention that combines a high water flow suction device that incorporates an ion generator and a chemical chamber that releases a chemical that operates with high velocity water flows over 70 gallons per minute except the present disclosed invention. There is no invention that combines a high water flow suction device that incorporates an ion generator and a chemical chamber that releases a chemical that works with high velocity water flows over 70 gallons per minute and further comprises a filter that works with high velocity water flows of over 70 gallons per minute except for the present disclosed invention.

[0065] The main aspect of the present invention is to provide a suction fixture and non chemical purification device combination apparatus in a whirlpool bath that inhibits bacteria during whirlpool bathtub use and inhibits bacteria formation of biofilm in the whirlpool bathtub closed loop plumbing between uses.

[0066] Another aspect of the present invention is to provide a combination non chemical purification device and suction fitting that is designed to pass all ASME standards to be used on a whirlpool bathtub, such combination device allowing water in a whirlpool bathtub to pass a non chemical purification device at a high velocity/flow and impact an electrode or electrodes and operating to be effective with flow rates over 70 gallons per minute.

[0067] Another aspect of the present invention is to provide a safety flapper or other means to that shuts down suction force in the sanitation suction device if the antimicrobial chamber is absent, or improperly inserted and prevents body entrapment, hair entrapment, and broken bones.

[0068] Another aspect of the present invention is to provide a non-electric safety/sanitation cavitation port to cause cavitation, which shuts down or fractionally limits the suction force in the suction device if the combination purification device and faceplate is removed and/or a user partially blocks the suction device's housing inlet.

[0069] Another aspect of the present invention is to provide for a combination suction and removable purification device that also has a removable chemical chamber, where the chemical releases approximately equal metered low doses of antimicrobial additives over a range of bath cycles.

[0070] Another aspect of the present invention is to provide for a combination suction and non-removable purification device, that releases equal metered low doses of antimicrobial additives over a range of bath cycles and where the antimicrobial dispenser is in axial alignment with the faceplate and is attached to the faceplate.

[0071] Another aspect of the present invention is to provide a removable or non-removable purification device that releases antimicrobial into the whirlpool bathtub to kill bacteria during whirlpool bathtub operation and to inhibit bacteria growth in the whirlpool bath closed loop plumbing system for a polarity of bath cycles before the purification device needs to be replaced or the antimicrobial properties need replenishing.

[0072] Another aspect of the present invention is to provide for a combination suction and removable non chemical purification device and suction device that allows over about 70 gallons per minute flow rates through the sanitation suction device and resists hair entrapment.

[0073] Another aspect of the present invention is to provide for a combination suction and non-removable purification device that allows over about 70 gallons per minute flow rates through the purification device.

[0074] Another aspect of the present invention is to provide an electrical magnetically actuated switch transmitting an electrical signal mechanism to prevent pump operation if the faceplate or combination purification device and faceplate are removed.

[0075] Another aspect of the present invention is to provide a non-electric safety/sanitation cavitation port to cause cavitation, which shuts down whirlpool bath suction force if the purification device is absent or improperly inserted.

[0076] Another aspect of the present invention is to provide a minimal water retention combination purification device and suction device that retains less than 10½ ounces of water after drain down.

[0077] Another aspect of the present invention is to provide for a purification device when inserted into a suction device installed on a whirlpool bathtub will not increase the vacuum to the suction line leading to the pump of the whirlpool bathtub by more than 25 inches of Hg or reduce the jet performance pressure by more than 30%.

[0078] Another aspect of the present invention is to provide a means to prevent whirlpool bath operation when the antimicrobial properties of the purification device have been exhausted using various means and only restart when the used purification device has been removed and replaced.

[0079] Another aspect of the present invention is to provide tub mount indicator lights that notifies the bather when it is time to replace the purification device.

[0080] Another aspect of the present invention is to provide an antimicrobial dispenser that is calibrated to deliver about ⅓ part per million to about 7 parts per million of bromine into the bath water in under a 60-minute timed bath cycle or in a manufacturer-set bath cycle.

[0081] Another aspect of the present invention is to provide for a combination suction and non-removable purification device whereby only the electrodes need to be replenished and not the entire purification device needs replacing.

[0082] Another aspect of the current invention is to provide an alternate embodiment that has a filter media surrounding the purification device.

[0083] Another aspect of the current invention is to provide an alternate embodiment that has a filter media surrounding the purification device where the filter will not clog under normal use for over 90 tub cycles.

[0084] Another aspect of the present invention is to place the non chemical purification device in other locations than in a suction fitting on a whirlpool bathtub.

[0085] Another aspect of the present invention is a retrofit design having the electrodes attached to a faceplate and a battery attached to the faceplate that sends a current to the electrodes.

[0086] Other aspects of this invention will appear from the following description and appended claims, reference being made to the accompanying drawings forming a part of this specification wherein like reference characters designate corresponding parts in the several views

#### BRIEF DESCRIPTION OF THE DRAWINGS

[0087] **FIG. 1** is a top perspective view of a whirlpool bathtub with a combination suction device and purification device installed.

[0088] **FIG. 2** is an exploded view of a combination suction device and purification device.

[0089] **FIG. 3** is a side exploded view of a combination suction device and purification device.

[0090] **FIG. 4A** is a front perspective view of a faceplate screen filter with attachment screw.

[0091] **FIG. 4B** is a rear perspective view of a faceplate screen filter with attachment Screw.

[0092] FIG. 4C is a side view of a faceplate screen filter with attachment screw, electrodes, current limiting device and power source.

[0093] FIG. 5A is a front view of an elbow, housing and safety screen.

[0094] FIG. 5B is a front view of an elbow, housing and safety flapper.

[0095] FIG. 6 is a top perspective view of an elbow.

[0096] FIG. 7A is a top perspective view of an antimicrobial assembly chamber.

[0097] FIG. 7B is a side exploded view of an antimicrobial assembly chamber, antimicrobial additive, spring and antimicrobial chamber cap and electrodes.

[0098] FIG. 8 is a cross sectional view of an elbow and housing, along with a side view of an antimicrobial assembly chamber and electrodes.

[0099] FIG. 9 is a cross sectional view of an elbow with antimicrobial assembly chamber inserted and safety flapper in an open mode to show draft slant of housing and electrodes.

[0100] FIG. 10 is a front view of a removable housing filter screen.

[0101] FIG. 10A is a front view of a removable housing filter screen inserted into a housing.

[0102] FIG. 11 is a side view of an elbow and housing using a standard 90-degree elbow.

[0103] FIG. 12 is a front view of a faceplate filter screen and faceplate filter screen attachment screw installed on a side wall of a whirlpool bath with two antimicrobial replacement indicator lights.

[0104] FIG. 13 is a top perspective view of a faceplate screen filter attachment screw.

[0105] FIG. 14 is a side view of an alternate embodiment of an antimicrobial chamber having a scale chamber and electrodes.

[0106] FIG. 15 is a side exploded view of an alternate embodiment faceplate screen filter having a removable antimicrobial chamber and electrodes.

[0107] FIG. 16 is a top perspective view of an alternate embodiment sanitation suction device with a top refill antimicrobial shaft and top fill electrode shaft.

[0108] FIG. 17 is a top perspective view of an alternate embodiment purification device that can be placed anywhere inline on a whirlpool bathtub.

[0109] FIG. 18 is a side exploded view of a one-piece faceplate and non-removable antimicrobial dispenser and electrode embodiment whereby the faceplate and antimicrobial combination is reusable and only the antimicrobial additives and electrodes need to be replaced.

[0110] FIG. 19 is a cross sectional view of an alternate embodiment one piece elbow and antimicrobial dispenser and electrodes whereby only the antimicrobial additives need to be replaced and the electrodes need to be replaced and not the complete antimicrobial dispenser.

[0111] FIG. 20 is a cross sectional view of an alternate housing and elbow embodiment that receives a one-piece faceplate and antimicrobial chamber and electrodes.

[0112] FIG. 21 is a front view of an alternate embodiment faceplate whereby the replaceable antimicrobial additives can be replaced from within the tub without removing the faceplate.

[0113] FIG. 22 is a side view of the embodiment of FIG. 21.

[0114] FIGS. 23A, 23B are side views of an alternate embodiment faceplate screen that provides a cost-effective retrofit for an existing suction fitting installed on a whirlpool bathtub.

[0115] FIG. 24 is a front view of the embodiment shown in FIGS. 23A, 23B.

[0116] FIG. 25 is an overhead view of the tub showing the present invention installed on the bottom of a whirlpool tub.

[0117] FIG. 26 is a side view of an alternate embodiment having a combination purification device in further combination with a standard pool skimmer.

[0118] FIG. 27 is a front view of the embodiment shown in FIG. 26.

[0119] FIG. 28 is a top perspective view of an alternate embodiment of a purification device having a deck mount that can be placed on the output side of a standard suction fitting.

[0120] FIG. 29 is a side view of the purification device of FIG. 28.

[0121] FIG. 30 is a side view of the antimicrobial chamber assembly and electrodes of the device of FIGS. 28, 29.

[0122] FIG. 31 shows an alternate embodiment antimicrobial dispensing and electrodes device whereby antimicrobial additives are added on a per-use basis.

[0123] FIG. 32 is a side view of an alternate embodiment faceplate screen that covers a standard faceplate screen.

[0124] FIG. 33 is an exploded view of a screen mechanism for a whirlpool bathtub output jet.

[0125] FIG. 34 is a perspective view of a purification device having a filter mounted thereon to screen debris.

[0126] FIG. 35 is a cross section view of a purification mechanism.

[0127] FIG. 36 is a cross section view of a filter attached to a faceplate with the A purification therein.

[0128] Before explaining the disclosed embodiments of the present invention in detail, it is to be understood that the invention is not limited in its application to the details of the particular arrangements shown, since the invention is capable of other embodiments. Also, the terminology used herein is for the purpose of description and not of limitation.

#### DETAILED DESCRIPTION OF DRAWINGS

[0129] Referring first to FIGS. 1, 16, and 17 a whirlpool bath water vessel 1 has a tub 6 with a standard tub wall 6A and a standard tub drain 205 (see FIG. 25). During whirlpool use the pump 3 circulates water via water return line 5,

air mixing pipe (not shown) and jets 75. Water is drawn from the filled tub 6 via suction water line 4 which is connected to the purification device 15 (not shown) mounted within the suction device 31. A system control box 12 activates the pump 3.

[0130] A combination safety cavitation and purification device cavitation air line 16 extends from sanitation suction device 31. See FIG. 1. When line 16 detects that housing 10B is partially blocked, pump 3 cavitates. Electric wire 10A connects to system control box 12. Wire 10A provides a signal from points 1070, 1071 (see FIG. 8), where purification device 15 contacts inlet orifice 30 of housing 10B. A microprocessor counter (not shown) in system control box 12 detects that the number of bath cycles, which can be preset, has been reached thereby indicating that purification device 15 should be replaced and that the electrical contact between points 1070, 1071 should be broken. When the preset limit has been attained, pump 3 receives no power until the contact between points 1070, 1071 is broken; signifying that purification device 15 or antimicrobial additive 17 has been replaced. An electrical line 14X extends from suction device 31 and goes into AC-DC converter box 15X. AC-DC converter box 15X is supplied with electricity from an (electrical source not shown). A current limiting device 0 (not shown) resides in converter box 15X. Current limiting device 0 could also be located in various locations on the whirlpool bathtub or remote from the whirlpool bathtub. Line 14X provides a low DC current to silver and copper electrodes 5XX anode and 6XX cathode. When water is present between the electrodes a small current of electricity (not shown) is allowed to flow between the electrode 5XX and 6XX, copper and silver ions are released into water from the positive electrode (anode). Silver and copper electrodes are shown by way and not example as many different alloys or metals that have antimicrobial properties could be used. Further, any quantity of electrodes could be used. The electrodes could also have many different shapes and sizes. The ions are swept into the closed loop plumbing system of the whirlpool bathtub 1 via suction line 4 by the rapid flow of water and become part of the closed loop plumbing system's water and the tubs water. Silver and copper electrodes are shown by way of example and not limitation. Other electrodes that have antimicrobial properties could also be used. The position of electrode 5XX and 6XX could be in various locations within suction device 31, or possibly in other locations on the whirlpool bathtub. The electrodes could be of various shapes and sizes. It is preferable that the current is less than about 500 milliamps.

[0131] Electric wire 10, 9 for green and red indicator lights 51, 52 respectively, (see FIG. 12) also connect to system control box 12 to a microprocessor counter (not shown). Indicator light 52 (red) indicates that antimicrobial additives 17 (not shown) in purification device 15 (not shown) have been exhausted or that electrode 5XX and 6XX have been exhausted. Conversely, indicator light 51 (green) indicates that purification device 15 contains antimicrobial additives 17 (not shown). While the current invention shows the antimicrobial chamber and chemical combined with electrodes 5XX and 6XX integrated with purification device 15, purification device 15 can operate with just electrode 5XX and electrode 6XX without the antimicrobial chamber 7X or chemical 17. Preferably, green light 51 indicates that 90 to 365 cycles of water or less has been run through purification device 15. Therefore, a green light assumes antimicrobial

assembly chamber 7X has a sufficient amount of antimicrobial additives 17 left in purification device 15 and electrode 5XX and electrode 6XX are operable to continue to sanitize the whirlpool bathtub. When 90-365 cycles has been counted, or any predetermined amount of cycles which can be set by the manufacturer, red light 52 comes on to alert the bather that it is time to change purification device 15 or replace antimicrobial additives 17 in assembly chamber 7X. When red light 52 comes on, the whirlpool bathtub will not operate until the user changes purification device 15 or replaces antimicrobial additives 17 in assembly chamber 7X. Chemical chamber 7X could be located in various locations in suction 31 or in whirlpool bathtub 1 (not shown). While the present invention shows a counter as a means to know when to replace purification device 15 other methods and means could be used and they still would fall into the scope of the present invention.

[0132] Referring next to FIG. 12, the suction device 31 is shown as seen by a bather in the tub of FIG. 1. The only visible portion of the suction device 31 is the faceplate screen 8 attached to the inner tub wall 6A by a half-turn attachment screw 7. The half-turn screw is offered by way of example and not of limitation; any screw or attachment means could be employed. Faceplate screen 8, having hole openings of greater than 1000 microns, acts as a filter. Drain slots 70 on faceplate screen 8 allow water to drain back into the tub after shutdown.

[0133] Two indicator lights are shown placed near the inside wall 6A of the whirlpool bathtub near the faceplate screen 8. However, the lights may be placed anywhere on tub 6. Similarly, the faceplate screen attachment screw 7 may be placed anywhere on the faceplate screen to attach the faceplate screen to the inner tub wall 6A.

[0134] FIGS. 2, 3 are exploded views of an embodiment of the faceplate screen and housing and the disclosed embodiment of suction device 31. The faceplate screen 8 is preferably round but could have any shape. Faceplate screen 8 also serves as a filtering mechanism by preventing large debris from entering the closed loop plumbing system of the whirlpool bathtub.

[0135] The faceplate screen housing 10B is attached to the inside surface of tub wall 6A by mounting the threaded portion 44 of faceplate screen housing 10B through optional gasket 13. Housing 10B is secured in place by housing nut 14 on the outer surface (back side) of tub wall 6A, extending through tub wall 6A via a standard size opening cut. Housing nut 14 is secured to elbow 23 preferably by gluing elbow 23 to the inside of housing 10B. Other means of attaching elbow 23 to housing 10B are possible. Removable housing screen 9A, having hole openings of less than 1000 microns, mounts on the faceplate screen housing 10B, whereby recess 46 of housing screen 9A coordinates with housing hole 28 on faceplate screen housing 10B. Housing hole 28 receives attachment screw 7 as screw 7 passes through hole 8A of faceplate screen 8. Faceplate screen 8 is thus mounted inside tub 6. As assembled and installed, suction device 31 preferably does not protrude beyond the line delineated by the upper lip of whirlpool bath water vessel 1, thereby maximizing installation or placement options of whirlpool bath water vessel 1.

[0136] The disclosed embodiment provides for an outlet orifice 29 having a diameter ranging from about at least 1 to about 3 inches. Guideline B-810 of the New Mexico Sizing of Plastic Pipe, herein incorporated by reference, shows that there is little friction loss when using 3" pipe with high water flow rates. Less restriction provides less of a drop in pressure out whirlpool bathtub jets 75. to further aid water flow, and thus further relieve pressure restriction out jets 75, while delivering over 70 to over 200 gpm through sanitation suction device 31 and meeting ASME hair entrapment standards, an alternate embodiment may have an outlet orifice 29 of over 1 $\frac{7}{8}$ " in diameter and a housing inlet orifice 30 of over 1 $\frac{7}{8}$ " in diameter. The diameter of inlet orifice 30 is sized to compensate for the restriction in water flow caused by the insertion of antimicrobial assembly chamber 15 and its attachment members into inlet orifice 30.

[0137] FIG. 13 illustrates the faceplate screen filter attachment screw 7. Half turn screw threads 62 mate with threads of housing hole 28 on faceplate screen housing 10B. Screw barb 63 secures attachment screw 7 to faceplate screen 8. Screw head 61 is exposed to the user. Slot 60 facilitates the tightening or loosening of screw 7.

[0138] FIGS. 4A, 4B, 4C present different views of faceplate screen 8 having half-turn attachment screw 7 inserted through hole 8A (see FIG. 2) of faceplate screen 8. Attachment screw 7 facilitates the removal of the faceplate screen 8.

[0139] The faceplate screen slots 1120 are designed and engineered in a radiating pattern to allow easier injection molding of screen 8. Faceplate screen 8 preferably has a faceplate center, FD, of greater than  $\frac{1}{4}$ " and a depth, d, of less than  $\frac{1}{2}$ ". Because faceplate screen 8 is designed to protrude less than  $\frac{1}{2}$ " into tub 6 when attached to housing 10B, providing much less protrusion than most current suction devices, more room is provided to the bather in the bathing area of the whirlpool bathtub. Faceplate screen slots 1120 are over 1000 microns in size.

[0140] As shown in FIG. 4B, the rear of the faceplate screen 8 has support ribs (also known as support bars) 25 to strengthen the antivortex center support 24 to prevent crushing. Faceplate support ribs 25 are designed in an X pattern, which offers outstanding structural integrity. The circular ribbing design adds tremendous strength to the center impact point, or the antivortex center support 24, of faceplate screen 8. Screw barb 63 secures attachment screw 7 to faceplate screen 8. Drain slots 70 on faceplate screen 8 allow water to drain back into the tub after shutdown.

[0141] Referring next to FIGS. 10, 10A, removable housing screen 9A has hole openings of less than 1000 microns. Removable housing screen 9A is mounted between faceplate screen 8 and housing 10B to screen smaller debris, i.e., hair, that may pass through the larger openings of faceplate screen 8 and to prevent such smaller debris from entering the closed loop plumbing system. Recess 46 coordinates with housing hole 28 on faceplate screen housing 10B which receives attachment screw 7 as it passes through hole 8A (see FIG. 2) of faceplate screen 8. Recess 47 on housing screen collar 48 coordinates with housing receiving slot 33 on faceplate screen housing 10B. Housing receiving slot 33 receives faceplate screen support 25A (see FIG. 4B) on the rear of faceplate screen 8.

[0142] Referring next to FIG. 4C faceplate 900 has anode 5XX and cathode 6XX with current limiting device 8X and energy source 9X. Energy source 9X could be a battery or another form of energy source. Energy source 9X could be in any shape or size and be located anywhere on a suction device or whirlpool bathtub or a faceplate. Current limiting device 8X could be of any shape or size and could be located anywhere on a suction device or whirlpool bathtub or faceplate. If energy source 9X were a battery, multiple cells or batteries could be used, as necessary to meet dielectric requirements. The anode and cathode are shown as round only by way of example and not limitation. They also could be strips or have various other shapes and be in various sizes. Using strips, the strips could have a stickem or other means to fasten the strips to a part of the purification device. The energy source and current limiting device are preferable sealed in a water tight encasement.

[0143] FIG. 5A illustrates the disclosed embodiment of the elbow 23, housing 10B, and elbow safety screen 22. Water passes through antimicrobial assembly chamber 15 (not shown) and elbow inlet orifice 36, bypasses antivortex vanes 35 and passes through elbow outlet orifice 29, whereby the filtered water circulates back into the water vessel system. See also FIG. 6. Elbow safety screen 22 resides within elbow inlet orifice 36 between the inlet orifice 36 and antimicrobial assembly chamber 15 (see FIG. 2) and prevents the safety flapper 21 from getting sucked into elbow 23. Safety screen 22 also prevents hair and body entrapment if faceplate screen 8 and replaceable antimicrobial assembly chamber 15 are missing in a drained whirlpool bathtub. Flat recess 65 on the housing of elbow 23 preferably receives flat recess 43 on antimicrobial assembly chamber 15. A flat recess on safety screen 22 facilitates the placement of safety screen 22 against flat recess 65 on the housing of elbow 23. Safety cavitation port hole 27 is located on the wall of housing 10B. If a user runs the system without having faceplate screen 8 attached and places any body part near housing inlet orifice 30, ambient air is drawn into port hole 27 directly into pump 3 of the water vessel system, thereby causing pump 3 to draw more air than water and cavitate. Suction ceases before the user is harmed.

[0144] FIG. 5B illustrates the disclosed embodiment of the elbow 23, housing 10B, and safety flapper 21 in the closed mode, thereby enclosing elbow safety screen 22. Safety flapper hole 1031 on elbow 23 receives safety flapper screw 20. Flapper screw 20 secures safety flapper 21 in safety flapper recess 32. See also FIG. 6. Flapper screw 20 screws into safety flapper screw boss 45. See also FIG. 11. Housing receiving slot 33 on faceplate screen housing 10B receives faceplate screen support 25A (see FIG. 4B) on the rear of faceplate screen 8.

[0145] As shown in FIG. 6, purification device cavitation port hole 37 is located behind safety flapper 21 (not shown) in elbow 23 which is attached to the inside of housing 10B (not shown). When purification device 15 is absent or inserted improperly, safety flapper 21 closes and ambient air is pulled into suction line 4 of tub 6 and into pump 3. Without cavitation port hole 37, the seals in pump 3 might burn up at a fast rate when tub 6 were run with flapper 21 in the closed mode. Pump 3 would not only be starved for water, it would also be starved for air. The cavitation feature of the present invention allows air to enter pump 3, thereby allowing for longer run time before damage occurs to pump

3. The safety flapper is shown by way of example and not limitation as other means to inhibit the water suction flow of a pump could be used.

[0146] As seen in FIG. 11, combination safety cavitation and purification device cavitation air line 16 is coupled to safety cavitation port hole 27 (not shown) and purification device cavitation port hole 37 (not shown) by means of barbed combination safety cavitation and antimicrobial cavitation air line port 49. Elbow outlet orifice 29 of elbow 23 is connected to suction line 4 of a water circulation system. Elbow 23 of sanitation suction device 31 is readily installed into a standard size opening cut or formed into tub wall 6A (not shown). Elbow housing stop 50 prevents elbow 23 from protruding too far into housing 10B (not shown).

[0147] FIG. 11 illustrates elbow 23 of sanitation suction device 31 having a 90-degree radius R1 elbow adjacent to outlet orifice 29. Most elbows for standard suction fittings are not part of the suction fitting. They are usually added to the suction fitting by the whirlpool bathtub manufacturer who usually installs a standard 90-degree radius R1 elbow. However, a 90-degree sweep radius elbow may be employed. A sweep elbow provides for less cavitation than a standard 90-degree elbow and, therefore, offers more pressure out bathtub jets 75 for the same amount of pump horsepower exerted.

[0148] FIGS. 7A, 7B illustrate one embodiment of a replaceable purification device 15. Direct flow antimicrobial chamber 7X is shown centered with respect to antimicrobial chamber collar 38 by means of antimicrobial chamber supports 41. Direct flow antimicrobial chamber 7X receives chemical additive 17, e.g., a bromine stick. The bromine stick is offered by way of example and not of limitation; any suitable chemical in solid or granular form could be employed. A liquid chemical additive with a metering system could also be used. Moreover, any suitable chemical having antimicrobial properties could be utilized. Antimicrobial chamber 7X may be of any shape, although the disclosed embodiment described in this document specifies an antimicrobial chamber which is conically shaped. Chamber 7X has at least one opening and the opening could be in any shape or size and in various locations on chamber 7X. Antimicrobial chamber spring 18 or other mechanism pushes chemical additive 17 against the inner portion of chamber 7X. Antimicrobial chamber spring 18 is kept in place by means of antimicrobial chamber cap 19. Water flows through antimicrobial chamber slits or openings 40 at a high pressure and flow and directly impacts chemical additive 17 in chamber 7X, thereby dissolving chemical additive 17 in chamber 7X. Water containing antimicrobial additive 17 flows past antimicrobial chamber 39 and through housing 10B and elbow 23. Water additionally passes electrode 5XX and electrode 6XX. Water containing antimicrobial additive 17 and ions is directly injected into suction line 4 (not shown) of whirlpool bathtub 1 (not shown) and whirlpool bathtub pump 3 (not shown). As chemical additive 17 dissolves within chamber 7X, chamber spring 18 pushes any remaining chemical additive 17 against the inner portion of chamber 7X to keep the same amount of chemical additive 17 exposed to the water.

[0149] The size of each opening 40 can be adjusted by placing some sort of covering, such as tape or other means, over each opening 40, to close or partially close each

opening 40. The tape is offered by way of example and not of limitation; any suitable covering material could be employed. Additionally, there are other ways that the hole-open sizes could be adjusted. By covering each opening 40, each is made smaller to facilitate usage of the present invention with whirlpool bathtubs having smaller capacities or smaller horsepower pumps. Lower water flow (in gpm) results in less water flow over antimicrobial chamber 7X and a smaller release of antimicrobial additive 17. By merely adjusting openings 40, a predetermined, metered dose of chemical additives 17 can be delivered for any combination of whirlpool bathtub capacity or pump size. Moreover, each opening 40 can be custom sized or shaped to administer a desired dosage of additives without having to employ a means of covering the opening 40.

[0150] As stated above, bromine is offered by way of example and not of limitation; any suitable chemical in solid or granular form could be employed. However, using bromine as antimicrobial additive 17, it is preferable that antimicrobial chamber 7X be calibrated to deliver about 1:4 to 7 parts per million (ppm) bromine or another suitable antimicrobial additive into the bath water. This concentration of antimicrobial additives will leave residual antimicrobial additives in the closed loop plumbing system of the whirlpool bathtub after bath drain down. Such a residual concentration of antimicrobial additives inhibits bacteria growth in the whirlpool bathtub system between usages, while providing a desirable non-offensive odor to the bather. Ions (not shown) released from the anode also leaves a residual concentration of ions in the water. It is preferable, however, that the chemical chamber is calibrated to deliver less than 7 ppm of bromine or another suitable antimicrobial additive during a given bath cycle under one hour in duration.

[0151] FIG. 8 is a cross sectional view of elbow 23 and housing 10B, which illustrates how purification device 15 fits therein. The housing of elbow 23 is tapered from front to back to allow water to drain back into the tub after shutdown as shown by sloped drainage ledge 80. Safety flapper 21, which is held in place by means of safety flapper screw 20, is in the closed mode. Flapper screw 20 screws into safety flapper screw boss 45. To accommodate the configuration of pump 3 (not shown), elbow 23 may be installed such that the elbow outlet orifice 29 (not shown) may be oriented to the right or the left. Screw boss 45 is located on two portions of elbow 23 so that preferably safety flapper 21 flaps upwardly towards an upper portion of housing 10B when flapper 21 is in the open mode. In other words, regardless of whether the elbow outlet orifice 29 points toward the right or left on the outside of tub 6 (not shown), flap 21 can be attached by means of screw 20 in a screw boss 45 which is appropriately located on the upper half of elbow 23. Safety flapper support arm 42 holds flapper 21 upwardly towards an upper portion of housing 10B when flapper 21 is in the open mode. Flapper support arm 42 is offered by way of example and not a limitation. Any suitable support could be used.

[0152] Housing 10B is secured in place by housing nut 14 (see also FIG. 2) on the outer surface (back side) of the tub wall 6A. Housing nut 14 is secured to housing 10B. To install purification device 15, safety flapper 21 must be lifted from the closed mode, thereby exposing antimicrobial chamber cavitation port hole 37 which is located behind



safety flapper 21. Antimicrobial purification device collar 38 is inserted into elbow 23 until contact point 1071 on collar 38 meets up with contact point 1070 on the inlet orifice 36 of elbow 23 and collar 38 covers up port hole 37. Flat recess 43 of collar 38 mates up with flat recess 65 of elbow 23. Elbow safety screen 22 (see FIG. 2) may be placed between inlet orifice 36 and purification device 15.

[0153] FIG. 9 is a cross sectional view of elbow 23 and housing 10B, wherein purification device 15 is inserted. Safety flapper 21, which is held in place by means of safety flapper screw 20, is in the open mode. Safety flapper support arm 42 holds flapper 21 upwardly towards an upper portion of housing 10B adjacent to sloped drainage ledge 80 of elbow 23. Purification device collar 38 is shown inserted into housing 10B in contact with inlet orifice 36 of elbow 23. Flat recess 43 of collar 38 is mated up with flat recess 65 (not shown) of elbow 23. Elbow safety screen 22 may be placed between inlet orifice 36 and purification device 15 (see FIG. 2). Direct flow antimicrobial chamber 7X is shown centered with respect to purification device collar 38 in housing 10B and elbow 23. Housing receiving slot 33 on faceplate screen housing 10B receives faceplate screen support 25 (not shown) on the rear of faceplate screen 8 (see FIGS. 2, 5A).

[0154] FIG. 14 is a side view of another embodiment of purification device 15. In addition to direct flow antimicrobial chamber 39, purification device 15A has an anti-scale chamber 64 which houses a scale reducer substance (not shown). Such scale reducers help to prevent scale buildup in the whirlpool bathtub's closed looped plumbing system and inhibits biofilm development in the closed loop system. Additional alternate chambers may be included if desired.

[0155] FIGS. 15, 20 illustrate an alternate embodiment of a faceplate screen filter with a removable antimicrobial chamber and two electrodes, thereby forming a combination faceplate screen/antimicrobial chamber with two electrodes. All embodiments of the current invention could have singular or multiple electrodes. FIG. 15 is a side view of the combination faceplate screen/antimicrobial chamber/electrode. FIG. 20 is a cross-sectional view of elbow 23X and housing 10X, wherein faceplate screen 24B having a removable antimicrobial chamber 39 is inserted. Faceplate screen 24B, having hole openings of greater than 1000 microns, acts as a filter. Water flows through faceplate screen 24B in direction WF at a flow rate of over 70 gpm or so. In this embodiment, removable antimicrobial chamber 39 snaps into support bracket 66 which is an integral and non-removable part of faceplate screen 24B. Electrodes 5XX and 6XX are shown attached to faceplate screen 24B. Drain slots 70 on faceplate screen 24B allow water to drain back into the tub after shutdown. Faceplate screen 24B is inserted into housing 10X until contact point 1071A on faceplate screen 24B meets up with contact point 1070A on the housing 10X of elbow 23X. Housing receiving slot 33 on housing 10X receives faceplate screen support 25A (not shown) on the rear of faceplate screen 24B. Housing hole 28 receives attachment screw 7 (not shown) to attach faceplate screen 24B to the inner tub wall 6A. All embodiments of the current invention do not need the antimicrobial chamber and can just utilize the electrodes. The position and location of the chemical chamber and electrodes are shown by way of example and not limitation. The chemical chamber or additional chemical chambers and the electrode or electrodes could be placed anywhere in the faceplate or in the housing.

[0156] FIG. 18 illustrates an alternate embodiment of a faceplate screen filter with a non-removable antimicrobial chamber and electrodes which may also be used with elbow 23X and housing 10X shown in FIG. 20. In this embodiment, integrated unit 100 is a combination faceplate screen and antimicrobial chamber with electrodes. Non-removable antimicrobial chamber 82 is supported in place by means of antimicrobial chamber holding support 81. Electrodes 5xx and 6xx are attached to the faceplate screen of integrated unit 100. The faceplate screen of integrated unit 100, having hole openings of greater than 1000 microns, acts as a filter. Water flows through faceplate screen of integrated unit 100 in direction WF at a flow rate of over 70 gpm or so. Drain slots 70 on integrated unit 100 allow water to drain back into the tub after shutdown. Integrated unit 100 is inserted into housing 10X until contact point 1071A on integrated unit 100 meets up with contact point 1070A on the housing 10X of elbow 23X. Housing receiving slot 33 on housing 10X receives integrated unit screen support 25X (not shown) on the rear of integrated unit 100. Housing hole 28 receives attachment screw 7 (not shown) to attach integrated unit 100 to the inner tub wall 6A.

[0157] FIG. 19 is a cross sectional view of another embodiment showing a one-piece elbow 23A, housing 10B, and antimicrobial chamber 39A design with electrodes 5XX and 6XX. Whereas FIGS. 15, 18 show combination faceplate screen/antimicrobial chamber/electrodes units, FIG. 19 illustrates an integrated elbow/antimicrobial chamber/electrodes. Antimicrobial chamber 39A is non-removable and electrodes 5XX and 6XX are removable. In this integrated elbow/antimicrobial chamber/electrode configuration, only the antimicrobial additives 17 (not shown) and the electrodes need to be replaced and not the complete antimicrobial dispenser.

[0158] FIGS. 21, 22 illustrate an alternate embodiment of a faceplate screen filter with a non-removable antimicrobial chamber 201 whereby the antimicrobial additives can be replenished from within the whirlpool bathtub without having to first remove the faceplate. In this embodiment, integrated unit 200 is shown attached to inner tub wall 6A by a half-turn attachment screw 7. Indicator lights 51, 52 are shown placed near the inside wall 6A of the whirlpool bathtub near faceplate screen 200. Integrated unit 200, having hole openings of greater than 1000 microns, acts as a filter. Drain slots 70 on integrated unit 200 allow water to drain back into the tub after shutdown.

[0159] With this embodiment, a user removes antimicrobial chamber cap 19A and antimicrobial chamber spring 18. The user then places antimicrobial additives 17 in non-removable antimicrobial chamber 201 of integrated unit 200 and replaces antimicrobial spring 18 so it can push chemical additive 17 against the inner portion of chamber 201. Antimicrobial chamber cap 19A screws into antimicrobial chamber 201 by means of threads 18A. The cap could also have a snap fit configuration. Slot 18X facilitates the tightening or loosening of chamber cap 19A. Antimicrobial chamber 201 can also be removable if desired. In this case, the user need only open up chamber cap 19A, remove a spent antimicrobial chamber 201, insert another antimicrobial chamber 201 containing antimicrobial additives 17, and reinstall chamber cap 19A. With this embodiment, the key is not having to remove the faceplate screen. Here, antimicrobial chamber 201 is shown to be conically shaped and

supported by support bracket 266. However, antimicrobial chamber 201 can be of any configuration and a support bracket need not be used.

[0160] FIG. 32 shows an alternate embodiment faceplate screen that covers a standard faceplate screen. Here, sanitation faceplate screen 12000, having antimicrobial additives (not shown) placed at a back portion 12004 of sanitation faceplate screen 12000, fits over standard faceplate 12001. Water flows in direction WF, passes through hole openings in a front portion 12003 of sanitation faceplate screen 12000, and directly contacts antimicrobial additives (not shown) at back portion 12004. Water containing antimicrobial additives flows through faceplate 12001 in direction WF and into suction line 4 (not shown) of the whirlpool bathtub and the whirlpool bathtub pump. As shown, sanitation faceplate screen 12000 is similar in design to standard faceplate screen; sanitation faceplate screen 12000 snaps on over standard faceplate 12001. However, a similarly designed sanitation faceplate screen is offered by way of example and not of limitation as sanitation faceplate screen may be in various sizes and shapes. Further, sanitation faceplate screen 12000 may be attached to standard faceplate 12001 by any suitable attachments means. As one example, sanitation faceplate screen 12000 could be screwed on over standard faceplate 12001.

[0161] FIGS. 16, 17 present alternate embodiments of the present invention. In FIG. 16, combination safety cavitation and purification device air line 16 extends from sanitation suction device 31A. In this embodiment, sanitation suction device 31A has a shaft 31B which extends to the top of tub 6 at tub deck 6B so antimicrobial additives may be replaced by filling shaft 31B from fill cap 31C at tub deck 6B. The top fill configuration is offered by way of example and not of limitation, as shaft 31B may be installed such that antimicrobial additive replacement takes place at a side mount. In such a case, fill cap 31C would be mounted on a side wall of tub 6. By replacing antimicrobial additives via a fill shaft, liquid chemical additive with a metering system could also be used.

[0162] In FIG. 17, combination safety cavitation and purification air line 16 extends from sanitation suction device 31. In this embodiment, inline purification device 32D is shown installed on water return line 5. However, inline purification device 32D may be placed anywhere in the whirlpool bathtub closed loop plumbing. Inline purification device 32D extends to the top of tub 6 at tub deck 6B so electrodes may be replaced by inserting electrodes into inline device 32D from fill cap 31C at tub deck 6B so that ions may be released into the piping of the whirlpool bathtub system. Again, the top fill configuration is offered by way of example and not of limitation, as inline device 32D may be installed such that electrode replacement takes place at a side mount.

[0163] FIGS. 23A, 23B, 24 illustrate an alternate embodiment of the present invention that provides a cost-effective retrofit for an existing suction fitting installed on a whirlpool bathtub. First, a trade professional, usually a plumber, cuts an opening 1112 into faceplate screen 1100. Here, opening 1112 is shown in the faceplate screen center. However, opening 1112 may be placed anywhere on faceplate screen 1100. Then the trade professional places glue or any attachment means (not shown) behind retrofit antimicrobial cham-

ber 1105 at preferably an edge 1104, behind flange 1106. After inserting retrofit antimicrobial chamber 1105 into opening 1112 of faceplate screen 1100, whereby the glue or other attachment means secures at least edge 1104, behind flange 1106 to faceplate screen 1100, antimicrobial additive 17 is placed into retrofit chamber 1105. To complete the retrofit, the trade professional places retrofit antimicrobial chamber cover 1107 over retrofit antimicrobial chamber 1105 to form a combination faceplate screen and antimicrobial dispenser 1110.

[0164] When the whirlpool bathtub is activated with combination faceplate screen and antimicrobial dispenser 1110, water flow WF passes antimicrobial chamber 1105 which houses antimicrobial additives 17 and antimicrobial release opening 1108 on antimicrobial chamber 1105. Retrofit antimicrobial chamber 1105 could have multiple antimicrobial release openings 1108 that could be in various sizes, shapes, and positions on retrofit chamber 1105. Further, antimicrobial cover 1107 can be a snap on or screw on type of cover. As water passes by or comes into direct contact with antimicrobial additive 17, some of antimicrobial additive 17 is released into the plumbing of the whirlpool bathtub. Although this embodiment is shown using the faceplate screen configuration of faceplate screen 1100, the present invention may be used to retrofit any standard faceplate for a suction fitting. Further, retrofit chamber 1105 can be of any shape.

[0165] Just as the various combinations of faceplate/antimicrobial chamber/electrodes or elbow/antimicrobial chamber/electrode configurations are offered by way of example and not of limitation, the location of the configurations may also vary. The number of chambers and electrodes may also vary. Although the figures typically show the present invention mounted into tub wall 6A, any suitable tub mounting could be employed. FIG. 25 is an overhead view of the tub showing the present invention installed on the bottom of a whirlpool tub wherein only the faceplate screen 8 is visible.

[0166] FIGS. 26, 27 show a combination sanitation suction device 31 in further combination with a standard pool skimmer for low velocity flows, thereby forming combination unit 702. The upper skimmer section of combination unit 702 is presented as a cross-section. Low velocity water at the surface of the tub, or water line WL, flows into skimmer input orifice 700 in direction WF<sub>1</sub>, and through stem 703. This low velocity water flows into combination sanitation suction device 31, whereby it combines with high velocity water flowing in direction WF<sub>2</sub> through faceplate screen 8. The combined water then flows past antimicrobial assembly chamber 15 (not shown) that houses antimicrobial additives 17, past antivortex vanes 35 thereby reducing water vortexing, and into the whirlpool's closed loop plumbing system through output orifice 29 of elbow 23. Debris is skimmed off the water surface WL of tub 6 and collected on optional filter 701. The filter is offered by way of example and not of limitation; any debris-trapping means could be employed. Furthermore, the debris-trapping means could be replaceable. As water contacts antimicrobial additives 17 and electrodes 5XX and 6XX in purification device 15 (not shown), some of the additives leave the antimicrobial chamber and some of the ions leave the electrode and are directly injected into the suction line of the whirlpool bathtub and the whirlpool bathtub pump.

[0167] In FIG. 27, combination unit 702 is shown as seen by a bather. The only visible portions of the combination unit 702 are faceplate screen 8 which is attached to the inner tub wall 6A by a half-turn attachment screw 7 below water line WL, and tub attachment flange 704 of skimmer input orifice 700 at water line WL.

[0168] FIGS. 28, 29, and 30 show a deck-mounted antimicrobial dispensing and ion dispensing device 601 that can be placed on suction line 4 on the output side of a standard suction fitting 699. Water flows into standard suction fitting 699, into suction line 4, through device 601 that houses purification device 608 and passed electrodes 5XX and 6XX having collar 603 and antimicrobial additives (not shown), and through output orifice 606 as it enters the whirlpool's closed loop plumbing system. Purification device 608 is removable and is installed in device 601 by inserting chamber 608 into output orifice 606 until collar 603 seats output orifice receiving brackets 604, 1604. Receiving brackets 604, 1604 prevent antimicrobial assembly chamber 608 from getting sucked into suction line 4. Receiving brackets 604, 1604 are located on two portions of device 601 to facilitate installation. In other words, depending on the configuration or location of pump 3 (at the back or front of tub), device 601 can be installed so that purification device chamber 608 is in output orifice 606, or on the output side. Cap 602 is shown on tub deck 6B covering deck-mounted purification device 601.

[0169] Referring to FIG. 29, high velocity water enters device 601 via input orifice 605 in direction WF. As water contacts antimicrobial additives (not shown) in antimicrobial chamber 1602, some of the additives leave antimicrobial chamber 1602 and are directly injected into suction line 4 of the whirlpool bathtub and the whirlpool bathtub pump. As water contacts electrodes 5XX and 6XX ions are directly injected into suction line 4 of whirlpool bathtub and whirlpool bathtub pump. Optional filter media 607 may be placed over antimicrobial assembly chamber 608 as shown in FIG. 30, for example. FIG. 30 is referred to as an example, as a filter or other debris-trapping means can be placed over any of the alternate embodiment antimicrobial assembly chambers or electrodes of the present invention. As stated above, such debris trapping means could be replaceable. Thus, pump 3 (see FIG. 28) may be a reversible pump with a reversible impeller that backflows water through optional filter media 607 acting to dislodge debris from filter 607. Other types of self-cleaning mechanisms could also be employed.

[0170] Referring next to FIG. 31, a user drops chemical 2400 into receiving chamber 2100 mounted in tub deck 6B as desired. The under deck mount is offered by way of example and not of limitation, as receiving chamber 2100 may be installed at a side mount. Chemical 2400 enters inline holding area 2500. Screen 2600 prevents chemical 2400 from getting sucked into output orifice 2200, suction line 4 (not shown), and into pump 3 (not shown). Electrodes 6XX and 5XX are shown attached to screen 2600. The screen is offered by way of example and not of limitation; any blocking or screening means could be employed. Without screen 2600 or an appropriate blocking or screening means, the high velocity water from tub 6 would force all of chemical 2400 from inline holding area 2500 into the closed looped plumbing system.

[0171] High velocity water enters antimicrobial dispensing device 3000 via input orifice 2300 in direction WF. As water contacts chemical 2400 in inline holding area 2500, some of chemical 2400 leaves inline holding area 2500 and is directly injected into suction line 4 of the whirlpool bathtub and pump 3 (not shown) via output orifice 2200. Input orifice 2300 and output orifice 2200, both having diameters over about 1 inch, are designed for high flow rates over 70 gpm or so.

[0172] A sock shaped filter could also be attached to any of the faceplates of the present invention.

[0173] The present invention teaches the use of an antimicrobial assembly chamber and ion releasing electrodes in combination with a suction device in a whirlpool bathtub system. To further help inhibit bacteria in a whirlpool bathtub, at least one component of the whirlpool bathtub could have antimicrobial additives impregnated into the component. Thus, for optimal protection, it is preferable that all whirlpool bathtub components that come in contact with water, and potentially exposed to microorganism growth, be impregnated with antimicrobial additives. The current invention can be utilized without the chemical chamber and chemical or the optional filter. In other words, the purification device only needs the electrodes to inhibit bacteria in a whirlpool bathtub. The location of the purifying device with the electrodes could be placed in other locations on the whirlpool bathtub besides inside the suction device.

[0174] Referring next to FIG. 33, jet assembly mechanism 8600 comprises jet ring 8601, jet eyeball 8602, swivel brackets, 8603, 8604, assembly ring 1805, which are housed within orifice 8620 of jet assembly 8606. Jet housing nut 8608 and gaskets 8609, 8610 secure jet assembly 8606 to jet body 8611 having air cap 8612. Screen mechanism 8607 prevents large debris (not shown) from flowing back into jets 75 of tub 6 while tub 6 holds water in it during tub inactivation.

[0175] Without screen mechanism 8607, it is possible for debris to enter jet assembly 8600 and the whirlpool bathtub closed looped piping system, thereby creating an environment where microorganisms may grow. Thus, screen mechanism 8607 aids in inhibiting bacteria growth by preventing debris from entering the closed loop plumbing system via jet assembly 8606. Screen mechanism may be installed flush against orifice 8625 of jet assembly 8606. However, it could also be housed within orifice 8625. Preferably, screen mechanism 8607 has holes of less than 4000 microns in size.

[0176] Screen mechanism 8607 could be used in combination with purification device 15 having a filter 5410 that wraps around chamber 15 (see FIG. 34). Water enters filter 5410 in direction WF. As stated above with regard to optional filter media 607, any debris-trapping means can be employed. In addition, such debris-trapping means could be replaceable. Filter 5410 functions as a screening mechanism for debris that passes through screen mechanism 8607 or otherwise enters suction device (not shown). Such a combination could serve as an input and output filter for the closed loop plumbing, further providing a system to inhibit debris from entering the closed loop plumbing bacteria in a whirlpool bathtub from jets 75 or suction device 31.

[0177] Referring next to FIG. 34 purification device 15 has filter media 5410. Water flows in direction WF and passes electrodes 5XX and 6XX not shown. The filter media 5410 is made of a stretch type material. As the filter gathers debris, the debris and water pressure going through the filter media stretches the filter media. This increases the diameter of the pores in the filter media allowing small debris to go through the filter media. The filter media is designed to allow small debris to pass through the media but inhibits larger debris such as hair from entering the closed loop plumbing system. Therefore, the filter media used on the present invention will not clog or decrease the water pressure out the output jets by more than 30 percent over a polarity of bath cycles, e.g. 1 through 365 bath cycles. The filter media could also be impregnated with a metal that has antimicrobial properties.

[0178] Referring next to FIG. 35 purification device 41X is shown as a cross section. Chemical chamber 39X houses chemical tablet 21X. Spring 18 pushing tablet 18X forward in chamber 39X and against chemical release slot 40 in chamber 39X (not shown). Water flows in direction WF and impacts chemical 21X in chamber 39X through chemical release slot 40 (not shown). Some of chemical 21X releases from chemical chamber 39X. Energy source compartment 48X houses energy source 42X and current limiting device 43X. Wires 00 connect current limiting device 00 to electrode 5XX and electrode 6XX. Cap 09X water seals energy source compartment 48X. Water flow WF flows between electrodes 5XX and 6XX. As water flows between electrode 5XX and 6XX current is released. As current flows from electrode 6XX to electrode 5XX, electrode 5XX releases ions. Compartment 48X can be detachable from chemical chamber 39X. Therefore compartment 48X could be attached to a faceplate or any component of the purification device or a suction fitting.

[0179] Referring next to FIG. 36 water flows in direct WF through faceplate 1100X. Support member 49X secures purification device 41X to faceplate 1100X. Filter 700X attached to faceplate 1100X forming a combination. Filter 700X can be removable and replaceable to faceplate 1100X. Water flowing through faceplate 1100X and some of the water flows through chemical release slot 40 (not shown) and contacts chemical 21X in chemical chamber 39X. The water contacting chemical 21X releases chemical 21X from chemical chamber 39X. Water passes between electrodes 6XX and 5XX and 5XX releases ions. All water flows through filter 700X and filter 700X filters debris.

[0180] The present invention shows a direct current supplying energy to the purification devices electrodes. The purification device could also have a means to regulate the amount of current going to the electrodes. The higher the current the more ions are released into water. Also the purification device could supply current from a battery or by some other energy source. At least one battery could be attached to the faceplate along with the electrodes and a current limiting device. This would make the purification device ideal for retrofitting existing suction fittings. The battery could be a long lasting battery that always supplies energy to the electrodes, or the battery could be activated only when water contacts a component of the purification device. The battery is shown by way of example and not limitation. Other energy sources could be utilized. The

current invention could also incorporate a feature to control water pH or the whirlpool bath to have a feature to control water pH.

[0181] Although the present invention has been described with reference to various embodiments, numerous modifications and variations can be made and still the result will come within the scope of the invention. No limitation with respect to the specific embodiments disclosed herein is intended or should be inferred.

1-14. (canceled)

15. A water vessel, the improvement comprising:

a housing assembly having a mounting surface for providing a flush mount to the inside surface of the tub;

said housing assembly having an input orifice and an output orifice, and a shape to enable drainage;

said input orifice having a vertically oriented faceplate;

an ion generator located adjacent to said faceplate or attached to said faceplate;

said ion generator releasing ions into water having a high velocity water flow, whereby said water is directly induced into a suction line of the whirlpool bathtub leading to the water pump; and

wherein said ions inhibits growth of a microorganism in the water vessel during water vessel use or between whirlpool bathtub usages.

16. The apparatus of claim 15, wherein the housing assembly further comprises a non-electric cavitation port to shut down a suction force of the pump if the faceplate screen is removed.

17. The apparatus of claim 15, wherein the housing assembly further comprises a non-electric cavitation port to shut down a suction force of the pump if said input orifice is blocked.

18. The apparatus of claim 15, wherein the housing assembly further comprises a filter located adjacent to said faceplate.

19. The apparatus of claim 15, wherein the faceplate further comprises a chemical dispenser.

20. The apparatus of claim 15, wherein the housing assembly further comprises an electric shut off mechanism to shut down a suction force of the pump if the faceplate screen is removed or said input orifice is blocked.

21. The apparatus of claim 15 further comprising a skimmer to intake a low velocity water flow at the fill line of the tub.

22. The apparatus of claim 15 further comprising a screen mechanism to prevent debris from the tub from flowing into the output jets and entering the closed loop piping system.

23. A water vessel, the improvement comprising:

a housing assembly having a mounting surface for providing a flush mount to the inside surface of the tub;

said housing assembly having an input orifice and an output orifice, and a shape to enable drainage;

said input orifice having a vertically oriented faceplate;

an ion generator located adjacent to said faceplate or attached to said faceplate;

said ion generator having an anode and a cathode;

a power supply that provides current;

said ion generator releasing ions into water having a high velocity water flow, whereby said water is directly induced into a suction line of the whirlpool bathtub leading to the water pump; and

wherein said ions inhibits growth of a microorganism in the water vessel during water vessel use or between whirlpool bathtub usages.

**24.** The apparatus of claim 23, further having a chemical dispenser located adjacent to said faceplate or attached to said faceplate.

**25.** The apparatus of claim 23, further having a filter located adjacent to said faceplate.

**26.** A water vessel, the improvement comprising:

a housing assembly having a mounting surface for providing a flush mount to the inside surface of the tub;

said housing assembly having an input orifice and an output orifice, and a shape to enable drainage;

said input orifice having a vertically oriented faceplate;

an ion generator located adjacent to said faceplate or attached to said faceplate;

said ion generator having an anode and a cathode;

a power supply that provides current;

a current limited device that limits current to electrodes;

said ion generator releasing ions into water having a high velocity water flow, whereby said water is directly induced into a suction line of the whirlpool bathtub leading to the water pump; and

wherein said ions inhibits growth of a microorganism in the water vessel during water vessel use or between whirlpool bathtub usages.

**26.** The apparatus of claim 25, further having a chemical dispenser located adjacent to said faceplate or attached to said faceplate.

**27.** The apparatus of claim 25, further having a filter located adjacent to said faceplate.

**28.** The apparatus of claim 26, said chemical chamber having a single chemical release opening.

\* \* \* \* \*