

Sept. 4, 1962

H. BILL
APPARATUS FOR DELIVERING A LIQUID IN RATIONS
OF ANY AMOUNT UNDER ACTION
OF A COMPRESSED GAS
Filed May 12, 1959

3,052,377

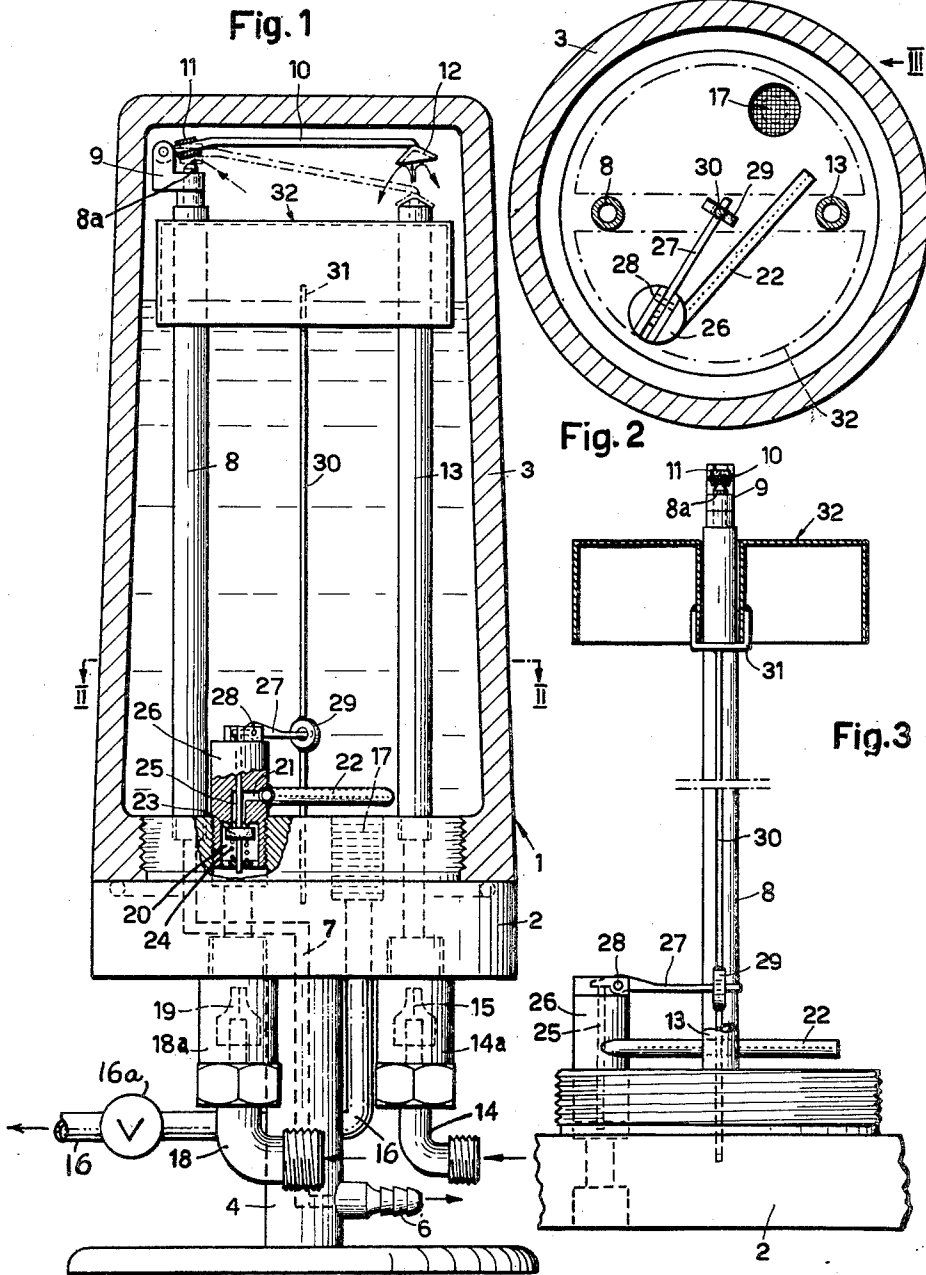

Inventor
Hugo Bill

By
Watson, Cole, Grindle & Watson
Attys.

1

3,052,377

APPARATUS FOR DELIVERING A LIQUID IN RATIONS OF ANY AMOUNT UNDER ACTION OF A COMPRESSED GAS

Hugo Bill, Bruhlbergstrasse 8, Winterthur, Switzerland

Filed May 12, 1959, Ser. No. 812,662

Claims priority, application Switzerland May 16, 1958

5 Claims. (Cl. 222—61)

This invention relates to an apparatus for delivering a liquid in rations of any amount under action of a compressed gas.

The apparatus comprises in known manner a container associated with a source of pressure liquid and a source of pressure gas, and connected to a discharge pipe with a manually operable closing member, means for automatically adjusting the supply of pressure liquid and pressure gas into the container, and an air vent pipe with an automatically closing vent valve, opening into the top of the container.

In an apparatus of the type known heretofore, the vent valve must each time be opened by hand at the same time as the closing member of the discharge pipe, for the purpose of automatically feeding pressure liquid and gas into the container during withdrawal of liquid.

Now it has been found that the vent valve, too, may be operated entirely automatically so that, merely by opening the closing member of the discharge pipe, liquid can be withdrawn from the container, whereby fresh pressure liquid and fresh pressure gas of the required amount are automatically fed to the container.

Through the apparatus according to the invention, this object is principally achieved in that an actuating member of the vent valve is entirely located within the container and so designed and arranged as to be acted upon by the pressure liquid flowing into the container on opening the discharge pipe, and automatically operated for opening the vent valve.

The apparatus may be particularly used for impregnating a liquid with gas and for dispensing in rations the impregnated liquid, say, for preparing and emptying syphons for beverages.

Other objects and features will be apparent from the following description and claims when read in connection with the accompanying drawing, in which there is shown, purely by way of example, one preferred embodiment of the object of invention, namely an apparatus suitable for caterers for preparing and emptying syphons, omitting for clarity of illustration the sources for the pressure liquid and pressure gas, together with a portion of the discharge pipe with the manually operable closing member.

In said annexed drawing:

FIG. 1 shows partly in side view and partly in vertical section essential parts of the apparatus;

FIG. 2 shows a horizontal section on line II—II of FIG. 1;

FIG. 3 is a view of details of the apparatus, partly in vertical section, seen in the direction of the arrow III of FIG. 2.

Referring to FIG. 1, numeral 1 designates the container made up of a base 2 and a substantially bell-shaped member 3 screwed thereon, which is placed on a bearing surface (not shown) by means of a foot 4. A vent 6 leading off the foot 4 is connected through a duct 7, running within foot 4 and base 2, to a vent pipe 8 which extends from the base 2 vertically up to near the top of the member 3, and is provided at its opening with a relatively narrow throttling nozzle 8a. Fitted to this end of the vent pipe 8 is a carrying fork 9 having pivoted thereto a swing arm 10. The latter carries a plug 11 of elastically yielding material, say, rubber, which serves for closing the vent pipe

2

8 and, according to the position of oscillation of the swing arm 10, is seated on the opening of the nozzle 8a or is raised therefrom. The element 6, 7 and 8 together constitute an air vent pipe, and the opening of the nozzle 8a and the plug 11 together constitute a vent valve.

At the free end of the swing arm 10 there is a feeler 12 in the form of a cap which, with its concave open side is directed downwards towards the outlet opening of a liquid supply pipe 13, and can be raised to the solid-line position by the liquid jet issuing from the mouth of the pipe 13. The swing arm 10 and the cap-like feeler 12 together constitute the actuating member of said vent valve 8a, 11 which is entirely located within the container 1 and closes automatically by the force of gravity.

The vertical pipe 13 is also attached to the base 2, in fact diametrically opposite the vent pipe 8. The pipe 13 communicates through an inlet branch 14a, in which a lipped non-return valve 15 is fitted, with a liquid supply pipe 14 (not shown to its full extent) which has to be connected to a source of liquid pressure (not shown) say, the drinking water mains.

A discharge pipe 16, led through the base 2, serves to withdraw liquid from the container 1 and includes, at its opening in the container, a throttling place formed by fittings 17 (not shown in detail) through which the liquid is only permitted to pass if subjected to a pressure above atmospheric. At the other end of the discharge pipe there is a serving cock 16a with a manually operable closing member for the discharge pipe 16.

A source of pressure gas (not shown) say, a carbon dioxide cylinder, is connected, via a lead 18 (only partially shown), a gas inlet 18a and an incorporated lipped non-return valve 19, to the container 1 which has in its base a valve chamber 20 connected to the interior of the container 1 through a duct 21 and a distributing pipe 22 provided with a plurality of lateral apertures. The opening of the duct 21 in chamber 20 is controlled by a gas admission valve 23 held in closed position by a valve spring 24. Said valve 23 is mounted on a stem 25 guided within an insert piece 26 which is screwed into the base 2 and contains at the same time the valve chamber 20. At its top, the stem 25 is pivoted to one arm of a two-armed lever 27 which is pivotally mounted at 28 within the insert 26 and engages with its longer arm a driver ring 29. The driver ring 29 is mounted on a connecting rod 30 which extends somewhat along the axis of the bell-shaped member 3, being guided with its bottom end within a bore in the base 2. The top of said rod 30 is joined to a two-part float 32 by means of a stirrup 31 (cf. also FIG. 3). The two parts of the float 32 are each designed in the form of half a circular disk and vertically movably guided respectively on the vent pipe 8 and pipe 13, when they are one side or the other of said pipes. Further, the elements of the float are hollow and open at their downward side.

Now let it be assumed that the container 1 is already filled with a gas-impregnated liquid, the float 32 being in its top position as shown, and the vent pipe 8 closed (chain-dotted position of the arm 10).

As the feeler 12 is not seated tight on the opening of the pipe 13, the internal pressure prevailing in the container 1 above the liquid surface and produced by the gas enclosed under the member 3, acts upon the liquid column in pipe 13 and, since the internal pressure is higher than the liquid pressure produced by the liquid source, no liquid can enter the container 1. By opening the swivel cock 16a at the discharge pipe 16, impregnated liquid escapes from the container 1, which is forced through the throttling place 17 by the pressure of the gas enclosed under the member 3 and possibly flowing until the valve 23 is closed. Incidentally the internal pressure in container 1 falls below that of the pressure liq-

uid in pipe 13 and inlet branch 14a in front of the non-return valve 15. The pressure liquid then runs out of the pipe 13 into the container 1, whereby the liquid jet forces the feeler 12 upwards so as to cause the arm 10 to swing upwards and the vent valve 8a, 11 to open. Then the gas cushion enclosed under the bell-shaped member 3 can escape through the air vent pipe 8, 7, 6 and more liquid is admitted to the container 1. The liquid surface will rise and the gas cushion enclosed under both parts of the float 32 will be compressed. At a certain definite degree of compression, the float 32 will be suddenly driven upwards, whereby the two halves of the float on both sides of the arm 10 can rise up to the top of the member 3 so that the gas inlet valve 23 will be rapidly and widely opened, and pressure gas will rush at high velocity into the container 1 and impregnate the liquid. In spite of the opened vent valve 8a, 11, the internal pressure in the container will immediately exceed the liquid pressure prevailing in pipe 13, so that the supply of liquid will be stopped automatically. The swing arm 10 then descends immediately with the feeler 12 into the broken line position, the plug 11 closing the vent pipe 8. Gas is further admitted until pressure equilibrium has taken place between the interior of the container and the gas supply pipe. Only at this pressure—and provided that the serving cock has been kept open—will liquid be forced anew through the throttling member 17, and the described process is repeated as often as desired and as long as the discharge pipe 16 is closed. Also thereafter the apparatus will continue to work until an impregnated liquid supply under pressure will be available for withdrawal.

It is thus understood that a withdrawal in rations of liquid may take place by continuous or by temporary opening of the service cock, which is the only element of the apparatus that has to be operated by hand. Moreover, this advantage is supplemented by the fact that for the whole operation controlled by the service cock alone, there are only necessary one water supply pipe, one air vent pipe controlled by the described valve 8a, 11, and the automatic gas inlet valve 23 in the bottom of the container.

In case the liquid shall not be impregnated, the gas inlet is advantageously arranged above the liquid surface. On the other hand, the feed pipe for the liquid may open directly in the bottom of the container, of course, with the swing arm 10 suitably modified in design.

It is understood that the foregoing detailed description is given merely by way of illustration and that variations

may be made therein without departing from the spirit of the invention.

What I claim is:

1. Apparatus for impregnating a liquid with a gas and rationing the liquid by discharge of the desired amount under the action of the gas, comprising a container having a discharge pipe connected thereto, a manually operable closure member connected in the discharge pipe, a liquid feed pipe extending into the container and open to admit liquid thereinto and connected with a source of pressure liquid for feeding liquid into the container automatically when the pressure of the gas is withdrawn from the discharge pipe, a gas inlet pipe extending into the lower part of the container and connected to a source of gas under pressure, a float controlled valve in the container connected to a stem to close and open communication to the gas inlet pipe, a vent pipe extending into the upper part of the container and provided with a self-closing gas valve, and a movable feeler connected with said self-closing valve and arranged adjacent said liquid feed pipe and operative by jet action of the pressure liquid for automatically opening the vent pipe when pressure liquid enters the container.

2. Apparatus according to claim 1, wherein the vent valve includes a pivotally supported arm which carries a feeler movably arranged in front of the outlet of the feed pipe for the pressure liquid, said feeler capable of being thrust back by the admitted pressure liquid.

3. Apparatus according to claim 2, wherein the feeler is designed as a cap which is open towards the outlet of the liquid feed pipe.

4. Apparatus according to claim 2, wherein the vent valve includes a plug which is seated tight on the mouth of the air vent pipe and arranged on a pivotally supported arm.

5. Apparatus according to claim 2, wherein the pivoted arm is supported on a carrying piece attached to a pipe of the air vent.

References Cited in the file of this patent

UNITED STATES PATENTS

671,176	Bangs	Apr. 2, 1901
1,297,458	Garvey	Mar. 18, 1919
1,536,247	Valerius	May 5, 1925
2,188,402	Feis	Jan. 30, 1940
2,809,597	Fowler	Oct. 15, 1957