

June 17, 1930.

S. K. BUSH

1,764,003

PRICE TAG

Filed July 8, 1927

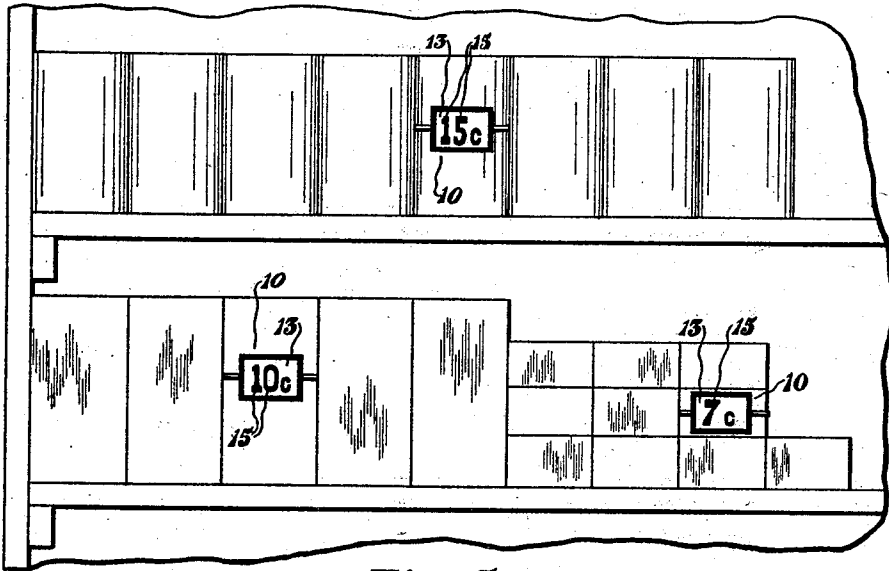

Fig. 5

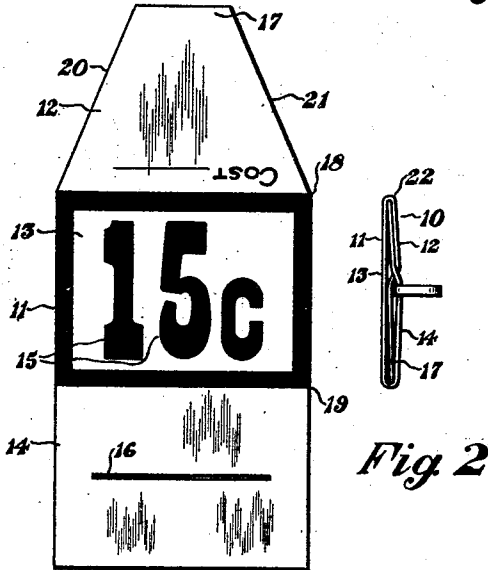

Fig. 2

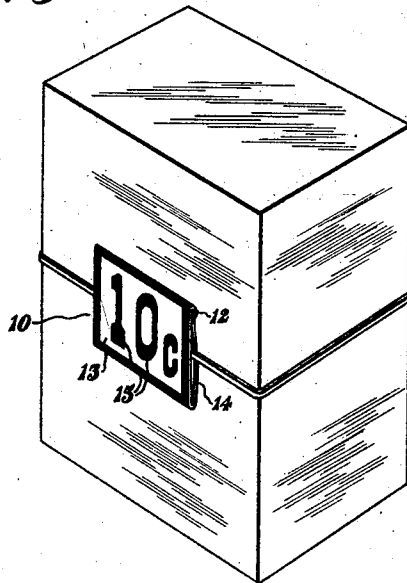

Fig. 1

Fig. 3



Fig. 4

Inventor

Sergins K. Bush

By

Freese and Bond Attorney

UNITED STATES PATENT OFFICE

SERGIN K. BUSH, OF CANTON, OHIO

PRICE TAG

Application filed July 8, 1927. Serial No. 204,265.

My invention relates to price tags for use in retail grocery stores and the like, where it is desired to display different articles of merchandise on shelves in containers ready for sale, such as cans, boxes and wrapped goods, and where it is desired that each different group of articles shall be unmistakably marked with a suitable price, whereby a customer upon entering the store may note the price of the different articles by merely glancing at the displayed price tags and without asking the salespeople the prices thereof.

Price tags have been used which are secured to the shelf beneath the articles or hung on wires adjacent the articles; but for using price tags in this manner, special clips or fasteners are generally required and there is danger that a price tag intended for one group of articles will be displaced sideways to another group of articles, thereby misleading the customer.

Moreover customers unfamiliar with the practice in any particular grocery will find themselves confused as to whether price tags secured to the shelf refer to articles above or below the shelf.

Accordingly, the objects of the present improvement are to provide an economical price tag equipped with means for securing it directly upon an article or container of merchandise having any usual size, shape or outer case, whether of metal, cardboard or the like, whereby a price tag therefore may be applied directly upon one of the group of articles, so that it will not be displaced from the group and will definitely indicate the price for the articles of the group.

These and ancillary objects are attained by a construction and arrangement hereinafter set forth in detail, and which may be described in general terms, as including a price tag having a price designation thereon, and provided with slidable means, preferably an elastic band, for securing the tag upon any desired article or container of merchandise.

A preferred embodiment of the invention is illustrated in the accompanying drawing, forming part hereof, in which

Figure 1 is an isometric view of a package provided with the improved price tag;

Fig. 2, a side elevation of the price tag;

Fig. 3, a developed view of the price tag with the fastening means removed;

Fig. 4, a detached view of the elastic band fastening means; and

Fig. 5, a fragmentary elevation view of shelves in a retail grocery store or the like having different groups of goods thereon and the improved price tags of the present invention applied thereto.

Similar numerals refer to similar parts throughout the several views.

The improved price tag indicated generally at 10 includes a strip 11 preferably of stiff paper or light pasteboard, and which is divided longitudinally into three zones 12, 13 and 14 substantially equal in length; and the central zone 13 has the desired price designating symbols 15 printed or otherwise applied thereon, while one end zone 14 is provided with a preferably centrally located slit 16 adapted to receive the tongue end 17 of the zone 12 when the zones 12 and 13 are folded towards and over each other about their respective intersections 18 and 19 with the central zone 13 as axes.

The zone 12 has its side edges 20 and 21 angled as illustrated to form the tongue end 17 adapted to pass through the slit 16.

The price tags thus formed are adapted to be secured to any usual size article or container of merchandise by means of an elastic band preferably slidably secured thereto by being interposed between the central zone 13, having on its outer face the price designating symbols 15, and the folded zones 12 and 14 secured against unfolding by means of the tongue end 17 passing through the slit 16 in the zone 14, the folded and fastened zones thus forming a sleeve 22, and the preferably centrally located slit 16, cooperating with the tongue end 17 provides means for centering the elastic band in one direction with reference to the sleeve.

By these means an economical and easily adjusted price tag is provided for application directly upon any desired article or container of merchandise, and easily adjusted thereon by reason of the elastic band being slidably enclosed in the sleeve.

55

60

65

70

75

80

85

90

95

100

The price tags thus described are adapted for application not only upon packaged articles, but also upon articles of all descriptions, such as fruit including oranges, apples and the like, vegetables, such as potatoes and the like, brooms and the like, and about which the elastic band may be stretched.

I claim:

1. A price tag for selective placement upon articles, containers and the like of varying size, including a strip having end portions cooperating to form a sleeve, a price designation on the sleeve, an endless elastic band removably slidable in the sleeve, and the cooperating end portions of the sleeve forming means for centering the band in one direction with respect to the sleeve.

2. A price tag for selective placement upon articles, containers and the like of varying size, including a strip having end portions cooperating to form a sleeve, a price designation on the sleeve, an elastic band removably linked with the sleeve, and the cooperating end portions of the sleeve forming means for centering the band in one direction with respect to the sleeve.

In testimony that I claim the above I have hereunto subscribed my name.

SERGINS K. BUSH.

30

35

40

45

50

55

60

65