



(51) International Patent Classification:

G05D 23/19 (2006.01) H02J 7/00 (2006.01)
H02J 15/00 (2006.01) H05B 1/02 (2006.01)

(21) International Application Number:

PCT/CA2015/050156

(22) International Filing Date:

2 March 2015 (02.03.2015)

(25) Filing Language:

English

(26) Publication Language:

English

(30) Priority Data:

61/946,158 28 February 2014 (28.02.2014) US

(71) Applicant: APPAREILS CONNECTÉS CASA LTÉE [CA/CA]; 2395 rue de l'Aéroport, St-Mathieu-de-Beloeil, Québec J3G 0C9 (CA).

(72) Inventors: FASSIER, Martin; 451 Auger, St-Amable, Québec J0L 1N0 (CA). PÉPIN, Patrick; 342 de Grenoble, Ste-Julie, Québec J3E 1A2 (CA).

(74) Agent: ROBIC LLP; Centre CDP Capital, Bloc E - 8th Floor, 1001 Square-Victoria, Montréal, Québec H2Z 2B7 (CA).

(81) Designated States (unless otherwise indicated, for every kind of national protection available):

AE, AG, AL, AM, AO, AT, AU, AZ, BA, BB, BG, BH, BN, BR, BW, BY, BZ, CA, CH, CL, CN, CO, CR, CU, CZ, DE, DK, DM, DO, DZ, EC, EE, EG, ES, FI, GB, GD, GE, GH, GM, GT, HN, HR, HU, ID, IL, IN, IR, IS, JP, KE, KG, KN, KP, KR, KZ, LA, LC, LK, LR, LS, LU, LY, MA, MD, ME, MG, MK, MN, MW, MX, MY, MZ, NA, NG, NI, NO, NZ, OM, PA, PE, PG, PH, PL, PT, QA, RO, RS, RU, RW, SA, SC, SD, SE, SG, SK, SL, SM, ST, SV, SY, TH, TJ, TM, TN, TR, TT, TZ, UA, UG, US, UZ, VC, VN, ZA, ZM, ZW.

(84) Designated States (unless otherwise indicated, for every kind of regional protection available):

ARIPO (BW, GH, GM, KE, LR, LS, MW, MZ, NA, RW, SD, SL, ST, SZ, TZ, UG, ZM, ZW), Eurasian (AM, AZ, BY, KG, KZ, RU, TJ, TM), European (AL, AT, BE, BG, CH, CY, CZ, DE, DK, EE, ES, FI, FR, GB, GR, HR, HU, IE, IS, IT, LI, LU, LV, MC, MK, MT, NL, NO, PL, PT, RO, RS, SE, SI, SK, SM, TR), OAPI (BF, BJ, CF, CG, CI, CM, GA, GN, GQ, GW, KM, ML, MR, NE, SN, TD, TG).

Published:

— with international search report (Art. 21(3))

(54) Title: THERMOSTAT UNIT AND ASSOCIATED SYSTEM AND METHOD

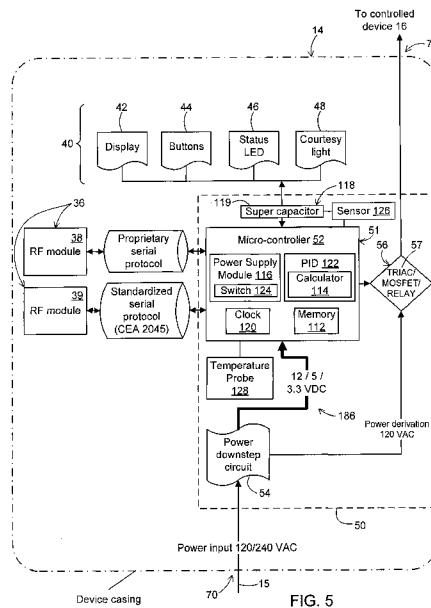

(57) Abstract: The present invention relates to a thermostat system, to a thermostat unit, as well as to a method for managing power supply in a thermostat unit. A thermostat unit is connected between a power supply and a resistive heating element. Input power is received at the thermostat unit. A temperature difference is calculated between a target temperature and a current temperature. The input power is controlled by operating a power supply module between a heating mode wherein in the input power is channelled to the output port for feeding the resistive heating element based on the temperature difference and a regenerative mode wherein the input power is channelled to an energy storage device for charging said energy storage device in order to supply power therefrom to electronic components of the thermostat unit.

WO 2015/127566 A1

THERMOSTAT UNIT AND ASSOCIATED SYSTEM AND METHOD

FIELD

5 The present invention relates to the field of thermostats. More particularly, the present invention relates to a thermostat system, to a thermostat unit, as well as to a method for managing power supply in a thermostat unit.

BACKGROUND

10

Programmable thermostat units are commonly used in cool climates for controlling electric baseboard heaters. It is desirable to further enhance the thermostat units to better manage the energy consumption in a given home or building area. For example, an interface may be added to each thermostat unit to
15 be in communication with each other and/or with a central control system. Moreover, solid-state controls such as TRIACs are not as energy-efficient as other means of switching, making it desirable to implement a better solid-state switching solution.

20

However any additional electronic component or feature added to the thermostat units requires energy from the electric source in order to operate it. Further, as is known, such thermostat units are connected in a 2-wire configuration known as line-to-line, as illustrated in FIG. 1A for electric baseboard heaters. As can be seen, the 2-wire (L_1 and L_2) configuration does not provide a "ground" to allow for
25 a difference of potential to exist. Therefore, it is challenging in such a configuration to provide a stable and reliable flow of energy to the circuit and/or other electronic component(s) of the thermostat. This challenge is further apparent in an "in-line" configuration, where only L_1 or L_2 is available to power the thermostat (i.e. L_1 and L_2 are connected through different electrical boxes).

30

Moreover, it is also desirable for the operative components to remain latent for weeks or months in order to monitor room temperature during periods of the year when heating is not needed. It is also desirable to provide an improved system which is reasonably priced, thereby limiting the hardware-based solutions. It is
5 also desirable to provide a system which is compatible with many communication protocols and that may be retrofitted by a user, both in its physical installation and its communication systems.

Therefore, there is a need for an improved system for electric heater thermostats
10 provided with communication module for centrally controlling the thermostats in a more energy efficient manner. Such centralized control devices are already marketed for furnace-type heating or cooling systems, but those devices are fed DC current by the equipment they are controlling, as shown in FIG. 1B. Also, there is typically a single unit in a centrally-configured system while baseboard-
15 heating operation requires one unit per room and typically one unit per heater thus making the networking capability more important.

Known to the Applicant are United States patents Nos. US 7,476,988 B2 (MULHOUSE et al.); US 7,590,499 B2 (HA et al.); US 8,523,083 B2 (WARREN et
20 al.); US 8,550,370 B2 (BARRETT et al.), and United States patent applications Nos. 2013/0213952 A1 (BOUTIN et al.) and 2014/0000858 A1 (FRANK).

In light of the aforementioned, there is a need for an improved system which, by virtue of its design and components, would be able to overcome some of the
25 above-discussed prior art concerns.

SUMMARY

The object of the present invention is to provide a system which, by virtue of its
30 design and components, satisfies some of the above-mentioned needs and is

thus an improvement over other related systems and/or methods known in the prior art.

In accordance with an aspect, there is provided a method for managing power supply in a thermostat unit connected between a power supply and a resistive heating element, the method comprising: (a) receiving, via an input port, input power from a power supply; (b) providing a target temperature and a current temperature; (c) calculating, by means of a calculator, a temperature difference between the current temperature and the target temperature; (d) controlling the input power by operating a power supply module between a heating mode wherein in the input power is channelled to the output port for feeding the resistive heating element based on the temperature difference and a regenerative mode wherein the input power is channelled to an energy storage device for charging said energy storage device in order to supply power therefrom to electronic components of the thermostat unit.

In accordance with another aspect, there is provided a thermostat unit connectable between a power supply and a resistive heating element, the thermostat unit comprising: an input port for receiving input power from the power supply; a memory for storing a target temperature and a current temperature; a calculator integrated in a controller, for calculating a temperature difference between the current temperature and the target temperature; a power supply module integrated in the controller, for controlling the input power received; an energy storage device connected between the power supply module and electronic components of the thermostat unit; and an output port connected to the power supply module and being connectable to the resistive heating element, wherein the power supply module is operable between a heating mode wherein in the input power is channelled to the output port for supplying power to the resistive heating element based on the temperature difference and a

regenerative mode wherein the input power is channelled to the energy storage device, in order to supply power to said electronic components.

In accordance with yet another aspect, there is provided a thermostat system comprising: a central controller having a communication module for sending a control signal; and a plurality of the above-described thermostat units, wherein each thermostat unit is adapted to receive the control signal from the central controller via the communication module and to operate the power supply module in response to the control signal received.

In accordance with still another aspect, there is provided a non-transitory computer-readable memory storing data and instructions for execution by a processor to manage power supply in a thermostat unit, when the thermostat unit is connected between a power supply to receive input power supply via an input port, and a resistive heating element, said data and instructions comprising: code means for providing a target temperature and a current temperature; code means for calculating, by means of a calculator, a temperature difference between the current temperature and the target temperature; code means for controlling the input power by operating a power supply module of the thermostat unit between a heating mode wherein in the input power is channelled to the output port for feeding the resistive heating element based on the temperature difference and a regenerative mode wherein the input power is channelled to an energy storage device for charging said energy storage device in order to supply power therefrom to electronic components of the thermostat unit.

The objects, advantages and features of the present invention will become more apparent upon reading of the following non-restrictive description of preferred embodiments thereof, given for the purpose of exemplification only, with reference to the accompanying drawings.

BRIEF DESCRIPTION OF THE DRAWINGS

FIG. 1A (prior art) is a circuit diagram of a conventional electronic or mechanical thermostat **T** connected to an electric baseboard heater **B** in an in-line or 2-wire configuration

FIG. 1B (prior art) is a circuit diagram of a conventional thermostat **T** connected to a central heating furnace **F** and fed with DC current from the appliance.

10 FIG. 2A is a schematic diagram showing a thermostat system, in accordance with an embodiment of the present invention.

FIG. 2B is a schematic diagram showing a thermostat system, in accordance with another embodiment of the present invention.

15 FIG. 3 is a schematic diagram showing a portion of the thermostat system shown in FIG. 2A or 2B.

FIG. 4A is a schematic diagram showing a configuration of a thermostat unit
20 connected to a heater and to a breaker panel, in accordance with an embodiment.

FIG. 4B is a schematic diagram showing a configuration of a thermostat unit
25 connected to a heater and to a breaker panel, in accordance with another embodiment.

FIG. 5 is a schematic diagram showing components of a thermostat unit, in accordance with an embodiment.

FIG. 6 is a schematic diagram showing a method for operation a thermostat unit, in accordance with an embodiment.

5 FIG. 7 is an electronic diagram of a central processor unit (CPU) of a thermostat unit, in accordance with an embodiment.

FIG. 8 is an electronic diagram of a flash memory component of a thermostat unit, in accordance with an embodiment.

10 FIG. 9 is an electronic diagram of a CPU Low-DropOut (LDO) regulator component of a thermostat unit, in accordance with an embodiment.

FIG. 10 is an electronic diagram of a Serial Wire Debug (SWD) component of a thermostat unit, in accordance with an embodiment.

15

FIG. 11 is an electronic diagram of a CPU supply and decoupling component of a thermostat unit, in accordance with an embodiment.

20 FIG. 12 is an electronic diagram of a temperature and humidity sensor component of a thermostat unit, in accordance with an embodiment.

FIG. 13 is an electronic diagram of an ambient light control component of a thermostat unit, in accordance with an embodiment.

25 FIG. 14 is an electronic diagram of a liquid-crystal-display (LCD) LDO component of a thermostat unit, in accordance with an embodiment.

FIG. 15 is an electronic diagram of an LCD backlight control component of a thermostat unit, in accordance with an embodiment.

30

FIG. 16 is an electronic diagram of an LCD touchscreen controller component of a thermostat unit, in accordance with an embodiment.

5 FIG. 17 is an electronic diagram of an LCD component of a thermostat unit, in accordance with an embodiment.

FIG. 18 is an electronic diagram of an external universal serial bus (USB) input component of a thermostat unit, in accordance with an embodiment.

10 FIG. 19 is an electronic diagram of a universal smart network access port (USNAP) connector adapter input component of a thermostat unit, in accordance with an embodiment.

15 FIG. 20 is an electronic diagram of a buzzer component of a thermostat unit, in accordance with an embodiment.

FIG. 21 is an electronic diagram of Wifi component of a thermostat unit, in accordance with an embodiment.

20 FIG. 22 is an electronic diagram of a TRIAC assembly component of a thermostat unit, in accordance with an embodiment.

FIG. 23 is an electronic diagram of a power downstep component of a thermostat unit, in accordance with an embodiment.

25

FIG. 24 is an electronic diagram of another USB component of a thermostat unit, in accordance with an embodiment.

30 FIG. 25 is an electronic diagram of a supply measurement component of a thermostat unit, in accordance with an embodiment.

FIG. 26 shows electronic diagrams of a power management component for the supercapacitor of a thermostat unit, in accordance with an embodiment.

5 FIG. 27A is an image of a display screen of the thermostat unit shown in FIG. 5.

FIG. 27B is an image of a command buttons of the thermostat unit shown in FIG. 5.

10 FIG. 27C is an image of components of the thermostat unit shown in FIG. 5.

FIG. 28 is a diagram of features shown in FIG. 27A.

FIG. 29 is a diagram of features shown in FIG. 27B.

15

FIG. 30 is a flow chart of operations executed by the thermostat unit shown in FIG. 5.

20 FIG. 31 is a flow chart of operations executed by the thermostat unit shown in FIG. 5.

FIG. 32 is a flow chart of operations executed by the thermostat unit shown in FIG. 5.

25 **DETAILED DESCRIPTION OF THE DRAWINGS**

In the following description, the same numerical references refer to similar elements. The embodiments, geometrical configurations, materials mentioned and/or dimensions shown in the figures or described in the present description
30 are preferred embodiments only, given for exemplification purposes only.

Broadly described, with reference to the accompanying drawings, a wall-mount thermostat unit replaces existing bimetallic, mercury switch and electronic wall thermostats. The thermostat unit is connected to an electricity supply at 120V per leg and does not require a neutral. One or both legs of the 240VAC circuit may
5 be used to power the device. The device is configured to communicate with a remote management server, via the internet or alternatively with a home automation gateway enabling the homeowner to control all devices from a single location and with neighbouring devices in a mesh network in order to achieve
10 maximum heating capacity and energy conservation.

As better illustrated in FIG. 2A, 3, and 5, there is provided a thermostat system **10** comprising a central controller **12** integrated in a cloud based platform **66** (or cloud-based server), adapted to emit a control signal. The system **10** further
15 comprises a plurality of thermostat units **14** adapted to receiving the control signal from the central controller **12** in order to control the supply of power fed from the thermostat unit **14** to resistive heaters (or resistive heating elements **16**) in response to the control signal.

20 With reference to FIG. 4A and 4B, the resistive heating element **16** may be provided in a resistive heater which may be a line-voltage resistive-type baseboard heater **11** and/or motor driven forced-air resistive heater (fanned air heater). The thermostat unit **14** may be connected in a line-to-line configuration (FIG. 4A), or in an in-line configuration (FIG. 4 B) in relation to the baseboard
25 heater **11** and to a breaker panel **17**.

Referring now to FIG. 3, 5 and 6, each thermostat unit **14** is connectable between a power supply **15** and a resistive heating element **16**. The thermostat unit **14** comprises an input port **70** for receiving **212** input power from the power
30 supply **15**, a memory **112** for storing **214** a target temperature and a current

temperature, a calculator **114** for calculating **216** a temperature difference between the current temperature and the target temperature, a power supply module **116** for controlling **218** the input power received, an energy storage device **118** connected between the power supply module **116** and electronic components **40** of the thermostat unit **14**, and an output port **72** connected to the power supply module **116**. The input port **70** is connectable to the power supply **15** and the output port **72** is connectable to the resistive heating element **16**.

The memory **112**, the calculator **114** and the power supply module **116** are integrated in a controller **51** such as encryption-capable micro-controller **52**.

The power supply module **116** is operable between a heating mode **220** and an energy storage mode **222**. In the heating mode **220**, the input power is channelled to the output port **72** for supplying power to the resistive heating element **16** based on the temperature difference. In the regenerative mode **222**, the input power is channelled to the energy storage device **118** in order to recharge the energy storage device. Advantageously, the power is stored in the energy storage device is supplied to the electronic components **40** of the thermostat unit **14**.

20

In a particular embodiment, the energy storage device **118** comprises a supercapacitor **119**. In alternative embodiments, the energy storage device **118** may comprise one or more rechargeable battery or the like.

25 The electronic components **40** may include a display screen component, a button component, an LED component, a light component, a communication component. The electronic components **40** may further comprise the controller **51**.

The thermostat is equipped with a temperature probe **128** for reading the current temperature. The temperature probe **128** is connected to the micro-controller **52**. The target temperature may be received via the central controller **12** or via the display screen **42**.

5

The thermostat further comprises a proportional-integral-derivative (PID) controller **122** which comprises the calculator **114**. The thermostat further comprises a clock **120** in communication with the power supply module **116** in order to operate the power supply module **116** in the heating mode **220** during a heating period **224**, and to operate the power supply module in the regenerative mode **222** during a regenerative period **226**. The clock is integrated in the micro-controller **52**. The PID controller **122** is adapted to determine the heating period by calculating **228** a proportion of a default period **230** as a function at least of said temperature difference **216**. The PID controller **122** is in communication with the power supply module **116** in order to send to the power supply module **116** the heating period having been calculated **228**.

In addition, the power supply module **116** comprises a switch **124** in order to mutually exclusively engage each of said heating mode **220** and said regenerative mode **222**, that is to say, when the power supply module **116** is operated in the regenerative period, the heating mode **220** is interrupted.

The circuitry of the thermostat **14** further comprises a circuit switching mechanism **56** connected between the power supply module **116** and the output port **72**. The switching mechanism **56** comprises one or more triode for alternating current (TRIAC) **57**. In the heating mode **220**, the power is channelled through the TRIAC assembly **57** and to the output port **72**. Advantageously, the channelled power is switched between TRIACs in order to dissipate heat in an efficient manner. In an embodiment, the TRIAC assembly **57** comprises 6 TRIACs in order to dissipate heat more efficiently. In an alternate embodiment,

the circuit switching mechanism **56** may comprise a metal–oxide–semiconductor field-effect transistor (MOSFET) and/or a relay system, in addition to or as a replacement of said TRIACs.

- 5 The thermostat unit **14** is further equipped with a printed circuit board (PCB) **50** which includes the micro-controller **52**, the supercapacitor **119** and the TRIAC assembly **57**.

Further, the thermostat unit **14** comprises communication module **36** connected
10 to the controller **51**. The communication module comprises a radio-frequency (RF) transceiver **38, 39** which may be adapted to communicate one or more of the following communication protocols: Wi-Fi, Z-Wave, Zigbee™, Bluetooth™, Bluetooth™ LE and cellular. In some embodiments, the communication module **38, 39** is detachable from the thermostat unit **14**, that is to say, the thermostat
15 unit **14** includes a connector configured to receive the communication module **38, 39**, in order to connect and disconnect the communication module **38, 39** thereto.

FIG. 7 to 26 show electronic diagrams of various components of the thermostat unit **14** which are each mounted on the PCB **50**. Namely there are shown an
20 electronic diagram for each of the following components of the thermostat unit **14**:

- a central processor unit (CPU) component **150** (FIG. 7);
- a flash memory component **152** (FIG. 8);
- a CPU Low-DropOut (LDO) regulator component **154** (FIG. 9);
- 25 - a Serial Wire Debug (SWD) component **156** (FIG. 10);
- a CPU supply and decoupling component **158** (FIG. 11);
- a temperature and humidity sensor component **160** (FIG. 12);
- an ambient light control component **162** (FIG. 13);
- a liquid-crystal-display (LCD) LDO component **164** (FIG. 14);
- 30 - an LCD backlight control component **166** (FIG. 15);

- an LCD touchscreen controller component **168** (FIG. 16);
- an LCD component **170** (FIG. 17);
- an external universal serial bus (USB) input component **172** (FIG. 18);
- a universal smart network access port (USNAP) connector adapter input
5 component **174** (FIG. 19);
- a buzzer component **176** (FIG. 20);
- a WI-FI component **178** (FIG. 21);
- a TRIAC assembly component **57** (FIG. 22);
- a power downstep component **180** (FIG. 23);
- 10 - another USB component **182** (FIG. 24);
- a supply measurement component **184** (FIG. 25); and
- a power management component **186** (FIG. 26).

The supply measurement component **184** illustrated in FIG. 25 measures the
15 current (A) consumed by the resistive heating element **16** (see FIG. 3) for a given heating period. From the measured current (in amperes) and duration of the heating period (in seconds) the power consumed by the resistive heating element **16** may be calculated, for example on the cloud platform 66 (see FIG. 2A, for example).

20

The power management circuit **186** illustrated in FIG. 26 allows, for example, monitoring the supercapacitor, controlling the components powered by the supercapacitor, monitoring the CPU and switching off the CPU when the supercapacitor does not have sufficient charge to supply power to the CPU. The
25 power management circuit **186** further prevents backfeed.

As previously mentioned, the thermostat unit **14** may be integrated in a broader thermostat system **10**. With reference to FIG. 2A, the thermostat system **10** comprises a central controller **12** and a plurality of the above-described
30 thermostat units **14**. The central controller **12** is equipped with communication

module for sending a control signal and the thermostat units are each adapted to receive the control signal from the central controller **12** via the communication module and to operate the power supply module **116** in response to the control signal received. For example, the control signal may include data representing the target temperature.

The central controller **12** may be integrated in a central server, a cloud-based server **66**, a home automation gateway **18** (see FIG. 2B), and/or the like. The central controller **12** comprises a memory **13** for storing user settings and rules, and is adapted to control the operation of each thermostat unit **14** based on the user settings and rules.

In some embodiment, the communication module **36** of each thermostat unit **14** is further adapted to enable two-way communication with the central controller **12** and/or other thermostat units **14**.

In operation, FIG. 6, with further reference to FIG. 3 and 5, shows a method **200** for managing power supply in a thermostat unit **14** connected between a power supply **15** and a resistive heating element **16**.

The power supply module **116** is operated alternatively between the heating mode when power is supplied to the resistive heating element **16** for heating and to the regenerative mode when the power is supplied to the energy storage device **118** for storing power to be supplied to the electronic components **40** of the thermostat unit **14**. The heating and regenerative modes are repetitively alternated, resulting in a pulsing of the heating mode **220**. The heating mode **220** is operated during a heating period **224** and the regenerative mode **222** is operated during a regenerative period **226**.

When the demand for heating is high, for example when the current temperature is relatively low in comparison to the target temperature, then it is desirable for the heating period **224** to be relatively long. When the demand for heating is relatively low, for example, when the current temperature is approaching the target temperature or when the current temperature should be maintained (i.e. the current temperature is the same or almost the same as the target temperature), then the heating period **224** should be relatively short in order to avoid overheating. In yet another case, when the current temperature substantially exceeds the target temperature, it may be desirable to skip a heating period **224**, in order to allow lowering the current temperature.

A default period **230** is defined within which the heating mode **220** and the regenerative mode **222** are to be each executed once. The default period may correspond for example to 10 seconds. It is to be understood that the default period may vary depending on embodiments, or may even vary in time for in a particular implementation of the method. It will be readily understood also that the default period **230** may be set at the central controller **12** or within the micro-controller **52**.

Under conditions where maximum heating is required, the heating period may last 9.5 seconds, leaving 0.5 seconds to complete the default period of 10 seconds. A minimum of 0.5 is dedicated to recharge the energy storage device. Thus the maximum heating period is set to 9.5 seconds, that is to say 95% of the default period. For illustrative purposes, such maximum energy heating periods may be required when a current temperature is more than 3°C lower than the target temperature. The 0.5 seconds of operating in the regenerative mode, allows recharging at least in part the energy storage device, which must be kept charged at all times in order to supply power to the electronic components of the thermostat unit. Thus, although maximum power is demanded for the resistive heater, the 5% off-time (i.e. when the heating mode is interrupted) is negligible for

most heating needs in homes and buildings, and advantageously allows recharging the energy storage device.

As the current temperature approaches the target temperature, it is desirable to gradually shorten the heating periods in order to slow down the heating and avoid overshooting the target temperature. For illustrative purposes when the current temperature is about 2°C under the target temperature, the desirable heating period may be about 50% of the default period. In this context, this leaves about 5 seconds to operate the power supply module in the regenerative mode, or until the energy storage device is fully recharged. Finally, when the current temperature reaches the target temperature, a heating period of about 20% may be desirable, leaving even more time for the energy storage device to be recharged. In another case, if the current temperature is higher than the current temperature, for example by about 0.5°C or more, then the heating period should be 0% of the default period, leaving the entire default period to the regenerative mode.

The heating period is preferably gradually adjusted as the current temperature changes. In order to achieve this, a proportional-integral-derivative (PID) controller **122** is used in order to iteratively calculate the heating period demanded (i.e. a percentage or proportion of the default period), on the basis of the current temperature and target temperature. It is to be understood that a proportional-integral (PI) controller may be used as well, in accordance with some embodiments, which is equivalent to a PID controller having a derivative term of 0, as will be readily understood by the skilled person.

In addition, to the normal operation of the thermostat on the basis of the calculated heating period, depending on the usage made of the electronic components, the heating mode may be interrupted before the calculated heating period ends, when the energy storage module requires to be charged. In some

cases the heating mode may even be skipped for one or more iteration. There is thus a monitoring mechanism which forces the power supply module to operate in the regenerative mode when the energy storage device is lower than a threshold level, for example when the charge reaches 3 Volts (V) or lower.

5

The method **200** shown in FIG. 6, will now be described in other words, still with further reference to FIG. 3 and 5. As can be seen, input power is received **212** from a power supply **15** and directed to the power supply module **116**. A target temperature and a current temperature are provided **214** to the PID controller **122**. The PID controller **122** calculates **216**, by means of a calculator **114**, a difference between the current temperature and the target temperature. The input power is then controlled **218** by operating the power supply module **116** between a heating mode **220** in which in the input power is channelled to the output port **72** for feeding the resistive heating element **16** based on the temperature difference **216**, and a regenerative mode **222** wherein the input power is channelled to the energy storage device **118** for charging said energy storage device **118** in order to supply power therefrom to electronic components **40** of the thermostat unit **14**. The method **200** further comprises supplying power from the energy storage device **118** to said electronic components **40** of the thermostat unit **14**.

15
20

The PID controller **122** is adapted to calculate **228** the heating period on the basis of the calculated temperature difference **216**. More particularly, a default period **230** is further provided. The PID calculates a proportion of this default period **230** as a function of the temperature difference **216**. This proportion corresponds to a heating period which is sent to the power supply module **116**. It is to be understood that the calculated heating period **224** may vary at each iteration of the PID controller **122** based on a number of factors, including the difference between the current temperature and the target temperature.

25

30

The method **200** further comprises monitoring **234** a charge level of the energy storage device **118** in order to operate the power supply module **116** based on said charge level of the energy storage device **118**. More particularly, the charge level is captured by a sensor **126** and compared with a minimal threshold, and
5 when the charge level is below the minimal threshold, the power supply module is operated in the regenerative mode. The regenerative mode is engaged for a predetermined period of time, for example 1 second or until the charge level of the regenerative storage device reaches a predetermined level, for example 3V or less. The predetermined level may correspond to a full charge of the energy
10 storage device, according to embodiments. According to embodiment, operating the power supply module in the regenerative mode fully recharges the energy storage device when said regenerative mode is operated for a cumulative duration of about 1 second.

15 Under conditions when the energy storage device **118** is above the minimum threshold value, the power supply module **116** operates in the heating mode **220** during the calculated heating period **224**, and in the regenerative mode **222** during a regenerative period **226** on the basis of the heating period **224**. For example, the regenerative period **222** may begin for a given iteration when the
20 heating period **224** ends. Under such conditions (when the energy storage device does not require emergency recharging), the regenerative period **224** may have a duration corresponding to a difference between the default period **230** and the heating period **222** set, or a duration shorter than said difference.

25 As previously mentioned, the regenerative mode is operated while the heating mode is disengaged (i.e. when the heating mode is not operative), that is to say, the heating mode is interrupted in order to operate the power supply module in the regenerative mode. Thus, the power supply module **116** interrupts the heating mode to engage the regenerative mode, by means of the switch **124**. Similarly,
30 the power supply module **116** interrupts the regenerative mode to engage the

heating mode, by means of the switch **124**. Thus, the heating period and the regenerative period are mutually exclusive at any given time.

The method **200** further comprises transmitting data from the thermostat unit **14**
5 over a wireless network **19** (see FIG. 2A). The data may be transmitted to a cloud platform **66** (see FIG. 2A), for reporting back data to the central controller **12**. Such data may include, for example, a current temperature (i.e. the current temperature having been captured at the thermostat unit **14**), a current power consumption, an ambient lighting status, an owner of the device, a date/time, a
10 time zone, etc. The transmitting may be executed periodically at a set interval of time, for example, every 5 minutes, or in response to receiving a data request, for example, when a user accesses the user interface **42** of the thermostat unit **14**.

Other optional aspects and features

15

Various optional features and examples, and certain components for the thermostat system and operation will be described below. It should be understood that the features and examples described below may be combined with other aspects of the thermostat unit, system and method as described
20 hereinabove in accordance with various embodiments of the present invention.

As better illustrated in FIG. 2B, 3 and 5, there is provided a thermostat system **10** comprising a central controller **12** having a communication module for emitting a control signal. The system **10** further comprises a plurality of thermostat units **14**,
25 each thermostat unit **14** being connectable between a power supply **15** and a resistive heating element **16**, each thermostat unit **14** further comprising a communication module **36** for receiving the control signal from the central controller **12** in order to control the supply of power fed from the thermostat unit **14** to said resistive heater **16** in response to the control signal.

30

There is thus provided a thermostat unit for controlling a power supply to a resistive heater, the thermostat unit comprising: an input port connectable to a power supply; an output port connectable to a resistive heating element, for supplying power thereto; a communication module for receiving a control signal;
5 and a controller for supplying said power in accordance with the control signal.

The resistive heating element may be provided in a resistive heater which may be a line-voltage resistive-type baseboard heater and/or motor driven forced-air resistive heater (fanned air heater).

10

The thermostat comprises electronic components and a power management system for powering said electronic components with the power supply. The electronic components may include the controller, and may further include a display screen.

15

As better illustrated in FIG. 3, the thermostat unit **14** comprises an input port **70** connectable to a power supply; and an output port **72** connectable to the resistive heater **16**, for supplying power thereto.

20

As better illustrated in FIG. 4, the thermostat unit **14** further comprises a user interface **40** including a display screen **42**, command buttons **44**, status light-emitting diode (LED) **46** and a courtesy or night light **48** (LED lights on its bottom side, whose state, color and intensity is controllable either remotely via the interface or locally using the buttons **44**).

25

The thermostat unit **14** is further equipped with a printed circuit board (PCB) **50** which includes an encryption-capable micro-controller **52**.

Moreover, the communication module **36** of the thermostat unit **14** is provided by
30 a radio-frequency (RF) module **38**, **39** to enable two-way communication with

other units **14** and/or with the central controller **12**. The RF module **38, 39** may operate through a proprietary serial protocol and/or under a standardized serial protocol, such as ANSI-CEA 2045, as will be better explained further below.

5 According to a particular embodiment, the communication module **38, 39** of the thermostat unit **14** is a detachable communication component which allows for interchanging communication components of different communication protocols. Indeed, given the diversity of communication protocols available in the context of home automation, it is desirable to allow the user to choose or adapt the device
10 to the desired or required protocol. In one embodiment, the detachable communication component is provided by a ANSI-CEA 2045 compliant "U-Snap" module, changeable by the end user in order to interact with existing networks using Wi-Fi, Z-Wave, Zigbee or other proprietary home automation standards. Through the use of an ANSI-CEA 2045 compliant RF module **39** and micro-
15 controller, the end user has the choice of protocol to either adapt to the existing infrastructure or to create a new dedicated network.

Alternatively, the communication module **36** may be integrated with the thermostat unit **14**.

20

It is to be understood that, in accordance with alternate embodiments, the communication module may operate according to other wireless communication protocols such as Bluetooth™, Bluetooth™ LE, cellular, any suitable proprietary RF protocol put forth by utilities companies, and/or the like.

25

It is to be understood also that in some embodiments a same communication module may allow communication with other thermostat unit as well as with the central controller. In other embodiments, the communication module for communicating between thermostat units is operable in a first communication
30 protocol while the communication module for communicating with the central

controller is operable in a second communication protocol. It is to be understood also that a same communication module may be used to communicate with both other thermostat units and the central controller. It is to be understood also, that the thermostat unit is only in communication with the central controller, in accordance with some embodiments.

In addition, each thermostat unit **14** has a power downstep circuit **54**, which in accordance with some embodiments may comprise a "power stealing" and/or a "power harvesting" mechanism in order to provide sufficient current to power the PCB **50** and the RF module **38, 39** in a reliable and standard-compliant manner. The RF module **38, 39** is managed by the CEA2045 standard of voltage, amperage and duration.

Each thermostat unit **14** further comprises a circuit switching device **56** such as a TRIAC, MOSFET, or relay.

In the embodiment shown in FIG. 2B, a central controller **12** is provided by a home automation gateway **18**, which is further in communication with an internet gateway **20**. The home automation gateway **18** is adapted to communicate with each of the thermostat units **14**, via its communication module and to control the thermostat units **14** to operate in an efficient/optimal manner according to given rules and user settings. It is to be understood that depending on particular embodiment, the home automation gateway may not be necessary, for example when the RF protocol is standardized for internet protocol communication (e.g. WiFi, cellular).

Examples of user settings may include a particular temperature setting for a predetermined schedule. Another user setting may include setting a maximum temperature difference between rooms.

The system **10** thereby allows monitoring and optimization of electrical energy dedicated to heating. An internet gateway **20**, such as an internet router **32**, further allows for remote monitoring and management, for example via a computer device such as a laptop computer **24**, a smartphone **26**, a tablet computer **28**, desktop computer **30**, and/or the like, through a communication network **60** such as the internet **62**, preferably over a secure connection **64** to a cloud platform **66**, as depicted in FIGs. 2A and 2B. It is to be understood that a secure connections exists from the device all the way to the cloud (256b AES).

Advantageously, the networked thermostats **14** may communicate between each other and/or via the central controller **12** to operate in an energy efficient manner. Still advantageously, the thermostat system **10** and each of the thermostat units **14** may be monitored and/or controlled remotely through a computer device as described above, by a user of the thermostat system **10**, such as a home owner, and/or by a power supplier.

Following are some functional features of the thermostat unit **14**:

- pulse heating unit to prevent thermal overshoot (i.e. electronic switching of heating load allows for precise control of heat output, prevents heating beyond the set temperature on the thermostat);
- communicate with central gateway and/or other similar devices to exchange energy usage, room temperature, set point, clock and program information;
- receive local input via physical buttons on device;
- locally display information such as room temperature, set point, connection status;
- optional courtesy nightlight;
- optional room humidity sensor;
- PID logic controller (proportional integral derivative) which in turn controls pulsing of the load;

- “Non-pulsing” switching mode for motors and fan-equipped heaters;
- RF module enables “meshing” of all similar devices in a house, allows for centralized control and energy monitoring;
- Visual feedback RGB LED provide users with clear, non-intrusive feedback to their heating habits;
- Courtesy light built into the device, controlled locally and via remote commands;
- Non-mechanical “Up” button for local input of various controls;
- Non-mechanical “Down” button for local input of various controls;
- Mechanical, PCB-mounted “Reset” button for local input of various controls.

Following are some technical specifications of the thermostat unit **14**:

- 16 amps switched load on 240V, 60 Hz (50H, variation for EU is also to be considered);
- Electronic load switching (no relays);
- Single port for U-Snap/CEA-2045 DC module;
- 1-gang form factor;
- 2-wire configuration, line to line, no neutral;
- back-lit LCD display, LED display, electrophoretic ink display, or pixel matrix display;
- Non-mechanical up/down buttons (e.g. capacitive or resistive or touchscreen); LED courtesy light; and RGB LED visual feedback LED.

Following are certification standards which the thermostat unit **14** is compliant to in accordance with embodiments:

- RoHS
- ANSI-CEA2045 (USNAP)
- UL 60730
- CAN/CSA-C828-06

- CAN/CSA-22.2 NO 24-93
- UL 353

FIG. 27A, with reference to FIG. 28, shows components displayed on the display screen **42** of the thermostat unit **14**. Namely, the data header (a) displays a label "room temperature". This label may appear in a user chosen language which may be set via the display screen **42**. The temperature (b) is read by an onboard sensor, such as a probe mounted on the PCB **50**. The temperature appears in either Celcius or Fahrenheit (c) depending on a user setting. The temperature set point (d) displays the temperature as set by the controller when in an automatic mode or by the user when in a manual mode. The element intensity (e) displays the current state of the TRIAC: "FULL" when full on (not pulsating); "HALF" when pulsating; and "OFF" when no load is applied. A clock (f) displays the time. A manual mode indicator (g) displays an icon when a manual input is made. When the icon is not displayed, this indicates that the operation of the thermostat unit is automated, according to a programmed schedule. When the icon blinks slowly, this indicates that this thermostat unit is operating under a temporary manual mode where the automatic mode will resume at the next programmed event. When the icon blinks at a high frequency, this indicates that the thermostat unit is currently fully operated manually, in that the automated mode will not resume until the manual mode is switched off. An RF indicator (h) displays the state of uplink (or connectivity) via the RF module **38**. When it is not displayed, this indicates that the thermostat unit is not paired or networked. When the indicator blinks fast, the pairing mode is activated and the thermostat unit will be available for networking for the next three-hundred (300) seconds. When the indicator blinks slowly, this indicates an RF transmission error. When the indicator blinks three times quickly, it is an indication that the RF command was acknowledged. A key lock indicator (i) displays when physical up/down buttons have been disabled by the controller **12**.

FIG. 27B, with reference to FIG. 29, shows the functions of the command buttons **44**. The up/down buttons (j/k) are physical buttons operating "up", "down" and combined functions, in accordance with the sequence diagrams shown in FIGS. 10 and 11. More particularly, in FIG. 10, the sequence diagram **80** shows the steps executed by the micro-controller **52** when the up button (j) is pressed. In FIG. 11, the sequence diagram **82** shows the steps executed by the micro-controller **52** when the down button (i) is pressed. The reset button is a physical button operating a "reset" and combined functions, in accordance with the sequence diagram shown in FIG. 12. More particularly, the sequence diagram **84** of FIG. 12 shows the steps executed by the micro-controller **52** when the "reset" button (l) is pressed.

FIG. 27C shows the LED components **46**, **48** and associated functions. Namely, a status LED (m) provides visual feedback of load status and a night light LED (n) is controllable remotely by the interface **34**, **36** or locally using the buttons **44** on the thermostat unit.

In accordance with alternate embodiments, the display screen is a touch screen. In such embodiments, there may or may not be any physical buttons such as **44**. According to an embodiment, the thermostat unit comprises at least a "reset" button (l).

Although the above-described embodiments are directed to resistive heaters, it is to be understood that the thermostat system may alternatively or additionally apply to other heating devices such as water heaters or the like.

The above-described embodiments are considered in all respect only as illustrative and not restrictive, and the present application is intended to cover any adaptations or variations thereof, as apparent to a person skilled in the art. Of course, numerous other modifications could be made to the above-described

embodiments without departing from the scope of the invention, as apparent to a person skilled in the art.

Claims:

1. A method for managing power supply in a thermostat unit connected between a power supply and a resistive heating element, the method comprising:
5
a) receiving, via an input port, input power from a power supply;
b) providing a target temperature and a current temperature;
c) calculating, by means of a calculator, a temperature difference between the current temperature and the target temperature;
10
d) controlling the input power by operating a power supply module between a heating mode wherein in the input power is channelled to the output port for feeding the resistive heating element based on the temperature difference and a regenerative mode wherein the input power is channelled to an energy storage device for charging said energy storage device in order to supply power therefrom to electronic
15
components of the thermostat unit.
2. The method according to claim 1, wherein the controlling step (d) comprises operating the power supply module in the heating mode during a heating
20
period and operating the power supply module in the regenerative mode during a regenerative period.
3. The method according to claim 2, wherein the heating period has a duration of up to about 15 seconds.
- 25
4. The method according to claim 2 or 3, wherein the regenerative period has a duration between about 0.5 second and about 1 second.

5. The method according to any one of claims 2 to 4, further comprising after step (c), determining the heating period for the heating mode of step (d), on the basis of the temperature difference calculated at step (c).
- 5 6. The method according to claim 5, further comprising providing a default period, and wherein said determining the heating period comprises calculating by means of a proportional-integral-derivative (PID) controller a proportion of said default period as a fonction at least of said temperature difference.
- 10 7. The method according to claim 6, wherein the default period has a duration between about 9 second and about 15 seconds.
8. The method according to any one of claims 5 to 7, further comprising
15 monitoring a charge level of the energy storage device, by means of a sensor, wherein the controlling step (d) comprises operating the power supply module based on said charge level of the energy storage device.
9. The method according to claim 8, wherein said monitoring comprises
20 receiving said charge level and comparing said charge level with a minimal threshold, and wherein the controlling of step (d) comprises when the charge level is below the minimal threshold operating the power supply module in the regenerative mode.
- 25 10. The method according to claim 9, wherein said the regenerative mode is engaged for a predetermined period of time or until the charge level of the regenerative storage device reaches a predetermined level.
- 30 11. The method according to claim 10, wherein the predetermined level corresponds to a full charge of the energy storage device.

12. The method according to any one of claims 6 to 11, wherein the regenerative period of the regenerative mode in step (d) is determined based on the heating period of the heating mode.
- 5 13. The method according to claim 12, wherein the regenerative period includes a duration corresponding to a difference between the default period and the heating period set, or a duration shorter than said difference.
- 10 14. The method according to any one of claims 1 to 13, wherein the regenerative mode is operated while the heating mode is disengaged.
- 15 15. The method according to any one of claims 1 to 14, wherein step (d) comprises interrupting the heating mode to engage the regenerative mode.
- 15 16. The method according to any one of claims 1 to 15, wherein step (d) comprises interrupting the regenerative mode to engage the heating mode.
- 20 17. The method according to any one of claims 2 to 16, wherein the heating period and the regenerative period are mutually exclusive at any given time.
- 20 18. The method according to any one of claims 1 to 17, further comprising transmitting data from the thermostat unit over a wireless network.
- 25 19. The method according to claim 18 wherein said transmitting is executed periodically at a set interval of time.
- 25 20. The method according to claim 19 wherein said set interval of time is set to about 5 minutes.
- 30 21. The method according to any one of claims 18 to 20, further comprising receiving a data request and executing said transmitting in response to the data request.

22. The method according to any one of claims 1 to 21, wherein operating the power supply module in the regenerative mode fully recharges the energy storage device when said regenerative mode is operated for a cumulative duration of about 1 second.
- 5 23. The method according to any one of 1 to 22, further comprising supplying power from the energy storage device to said electronic components of the thermostat unit.
- 10 24. A thermostat unit connectable between a power supply and a resistive heating element, the thermostat unit comprising:
- an input port for receiving input power from the power supply;
 - a memory for storing a target temperature and a current temperature;
 - a calculator integrated in a controller, for calculating a temperature difference between the current temperature and the target temperature;
 - 15 - a power supply module integrated in the controller, for controlling the input power received;
 - an energy storage device connected between the power supply module and electronic components of the thermostat unit; and
 - 20 - an output port connected to the power supply module and being connectable to the resistive heating element,
- wherein the power supply module is operable between a heating mode wherein in the input power is channelled to the output port for supplying power to the resistive heating element based on the temperature difference and a regenerative mode wherein the input power is channelled to the energy storage device, in order to supply power to said electronic components.
- 25 25. The thermostat unit according to claim 24, wherein the energy storage device comprises a supercapacitor.
- 30

26. The thermostat unit according to claim 24 or 25, wherein said electronic components comprise the controller.
27. The thermostat unit according to any one of claims 24 to 26, wherein said
5 electronic components comprise at least one of: a display screen component, a button component, an LED component, a light component, a communication component.
28. The thermostat unit according to any one of claims 24 to 28, further
10 comprising one or more triode for alternating current (TRIAC) connected between the power supply module and the output port.
29. The thermostat unit according to claim 28, wherein said one or more TRIAC comprises 6 TRIACs.
- 15 30. The thermostat unit according to any one of claims 24 to 29, further comprising a clock in communication with the power supply module in order to operate the power supply module in the heating mode during a heating period, and to operate the power supply module in the regenerative mode
20 during a regenerative period.
31. The thermostat unit according to claim 30, further comprising a proportional-integral-derivative (PID) controller comprising said calculator, the PID controller being adapted to determining the heating period by calculating a
25 proportion of a default period as a function at least of said temperature difference, the PID controller being in communication with the power supply module to send the heating period having been calculated.
- 30 32. The thermostat unit according to any one of claims 24 to 31, wherein the power supply module comprises a switch in order to mutually exclusively engage each of said heating mode and said regenerative mode.

33. The thermostat unit according to any one of claims 24 to 32, further comprising a communication module connected to the controller.
34. The thermostat unit according to claim 33, wherein the communication
5 module comprises a radio-frequency (RF) transceiver.
35. The thermostat system according to claim 33 or 34, wherein the communication module is adapted to communicate over at least one of the following communication protocols: Wi-Fi, Z-Wave, Zigbee™, Bluetooth™,
10 Bluetooth™ LE and cellular.
36. The thermostat unit according to any one of claims 33 to 35, wherein the communication module is detachable from the thermostat unit.
- 15 37. The thermostat unit according to any one of claims 24 to 36, further comprising a temperature probe for reading said current temperature.
38. A thermostat system comprising:
- a central controller having a communication module for sending a
20 control signal; and
 - a plurality of thermostat units in accordance with any one of claims 33 to 36, wherein each thermostat unit is adapted to receive the control signal from the central controller via the communication module and to operate the power supply module in response to the control signal
25 received.
39. The thermostat system according to claim 38, wherein the communication module of each thermostat unit is adapted to enable two-way communication with at least one of: one or more other thermostat unit and
30 the central controller.

40. The thermostat system according to claim 38 or 39, wherein the central controller is integrated in at least one of: a central server, a cloud-based server and a home automation gateway.
- 5 41. The thermostat system according to any one of claims 38 to 40, wherein the central controller comprises a memory for storing user settings and rules, and wherein the central controller is adapted to control the operation of each thermostat unit based on the user settings and rules.
- 10 42. A non-transitory computer-readable memory storing data and instructions for execution by a processor to manage power supply in a thermostat unit, when the thermostat unit is connected between a power supply to receive input power supply via an input port, and a resistive heating element, said data and instructions comprising:
- 15 i) code means for providing a target temperature and a current temperature;
- ii) code means for calculating, by means of a calculator, a temperature difference between the current temperature and the target temperature;
- 20 iii) code means for controlling the input power by operating a power supply module of the thermostat unit between a heating mode wherein in the input power is channelled to the output port for feeding the resistive heating element based on the temperature difference and a regenerative mode wherein the input power is channelled to an energy storage device for charging said energy storage device in order to
- 25 supply power therefrom to electronic components of the thermostat unit.
43. The non-transitory computer-readable memory according to claim 42, wherein the codes means (iii) comprise code means for operating the power supply module in the heating mode during a heating period and for
- 30 operating the power supply module in the regenerative mode during a regenerative period.

- 5 44. The non-transitory computer-readable memory according to claim 43, wherein the codes means (iii) are configured to operate the power supply module in the heating mode for a heating period having a duration of up to about 15 seconds.
- 10 45. The non-transitory computer-readable memory according to claim 43 or 44, wherein the codes means (iii) are configured to operate the power supply module in the regenerative mode for a regenerative period having a duration between about 0.5 second and about 1 second.
- 15 46. The non-transitory computer-readable memory according any one of claims 43 to 45, wherein the data and instructions further comprise code means for determining the heating period on the basis of the temperature difference calculated by the code means (ii).
- 20 47. The non-transitory computer-readable memory according claim 46, wherein the data and instructions further comprise providing a default period, and wherein said code means for determining the heating period comprises a proportional-integral-derivative (PID) controller for determining the heating period by calculating a proportion of said default period as a fonction at least of said temperature difference.
- 25 48. The non-transitory computer-readable memory according claim 47, wherein the data and instructions are configured to set the default period to a duration between about 9 second and about 15 seconds.
- 30 49. The non-transitory computer-readable memory according to any one of claims 46 to 48, wherein the data and instructions, further comprise code means for monitoring a charge level of the energy storage device, wherein wherein the codes means (iii) are adapted to operate the power supply module based on said charge level of the energy storage device.

50. The non-transitory computer-readable memory according to claim 49, wherein said codes means for monitoring are adapted to receiving said charge level and compare said charge level with a minimal threshold, and
5 wherein the code means (iii) are adapted to operate the power supply module in the regenerative mode when the charge level is below the minimal threshold.
51. The non-transitory computer-readable memory according to claim 50,
10 wherein said codes means (iii) are adapted to engage the regenerative mode for a predetermined period of time or until the charge level of the regenerative storage device reaches a predetermined level.
52. The non-transitory computer-readable memory according to claim 51,
15 wherein the predetermined level corresponds to a full charge of the energy storage device.
53. The non-transitory computer-readable memory according to any one of
20 claims 47 to 52, wherein the data and instructions comprise code means for determining the regenerative period based on the heating period of the heating mode.
54. The non-transitory computer-readable memory according to claim 53,
25 wherein the regenerative period includes a duration corresponding to a difference between the default period and the heating period set, or a duration shorter than said difference.
55. The non-transitory computer-readable memory according to any one of
30 claims 42 to 54, wherein the codes means (iii) are adapted to operate the power supply module in the regenerative mode while the heating mode is disengaged.

56. The non-transitory computer-readable memory according to any one of claims 42 to 55, wherein the codes means (iii) are adapted to interrupt the heating mode to engage the regenerative mode.
- 5 57. The non-transitory computer-readable memory according to any one of claims 42 to 56, wherein the codes means (iii) are adapted to interrupt the regenerative mode to engage the heating mode.
- 10 58. The non-transitory computer-readable memory according to any one of claims 43 to 57, wherein the codes means (iii) are adapted to operate the power supply module such that the heating period and the regenerative period are mutually exclusive at any given time.
- 15 59. The non-transitory computer-readable memory according to any one of claims 42 to 58, further comprising codes means for transmitting data from the thermostat unit over a wireless network.
- 20 60. The non-transitory computer-readable memory according to claim 59 wherein said code means for transmitting data are executed periodically at a set interval of time.
- 25 61. The non-transitory computer-readable memory according to claim 60 wherein said set interval of time is set to about 5 minutes.
- 30 62. The non-transitory computer-readable memory according to any one of claims 59 to 61, further comprising code means for receiving a data request and executing, in response to the data request, said code means for transmitting data.
63. The non-transitory computer-readable memory according to any one of claims 42 to 62, wherein the codes means (iii) when operating the power supply module in the regenerative mode for a cumulative duration of about 1 second, fully recharges the energy storage device.

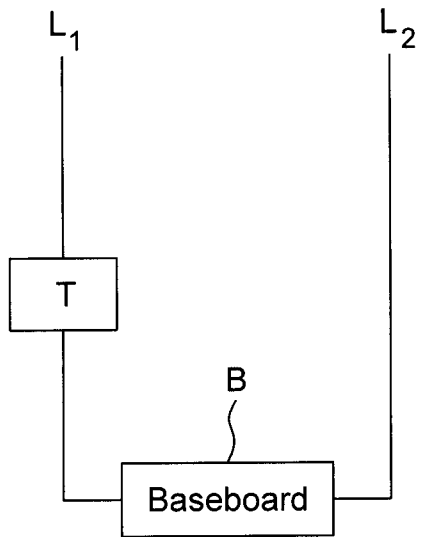

FIG. 1A
(PRIOR ART)

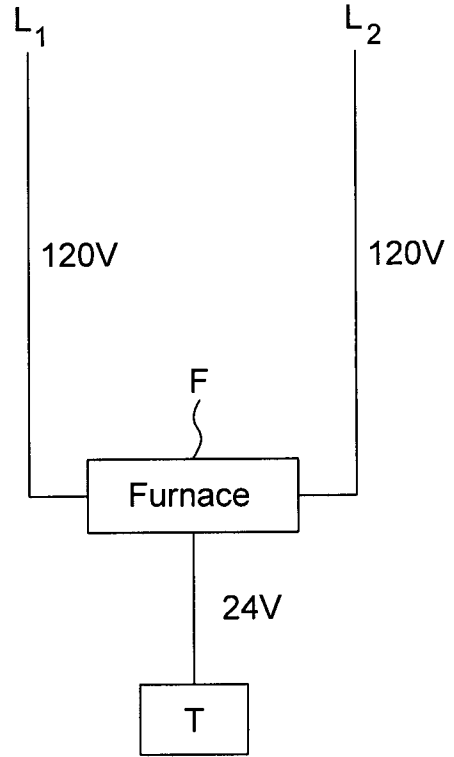

FIG. 1B
(PRIOR ART)

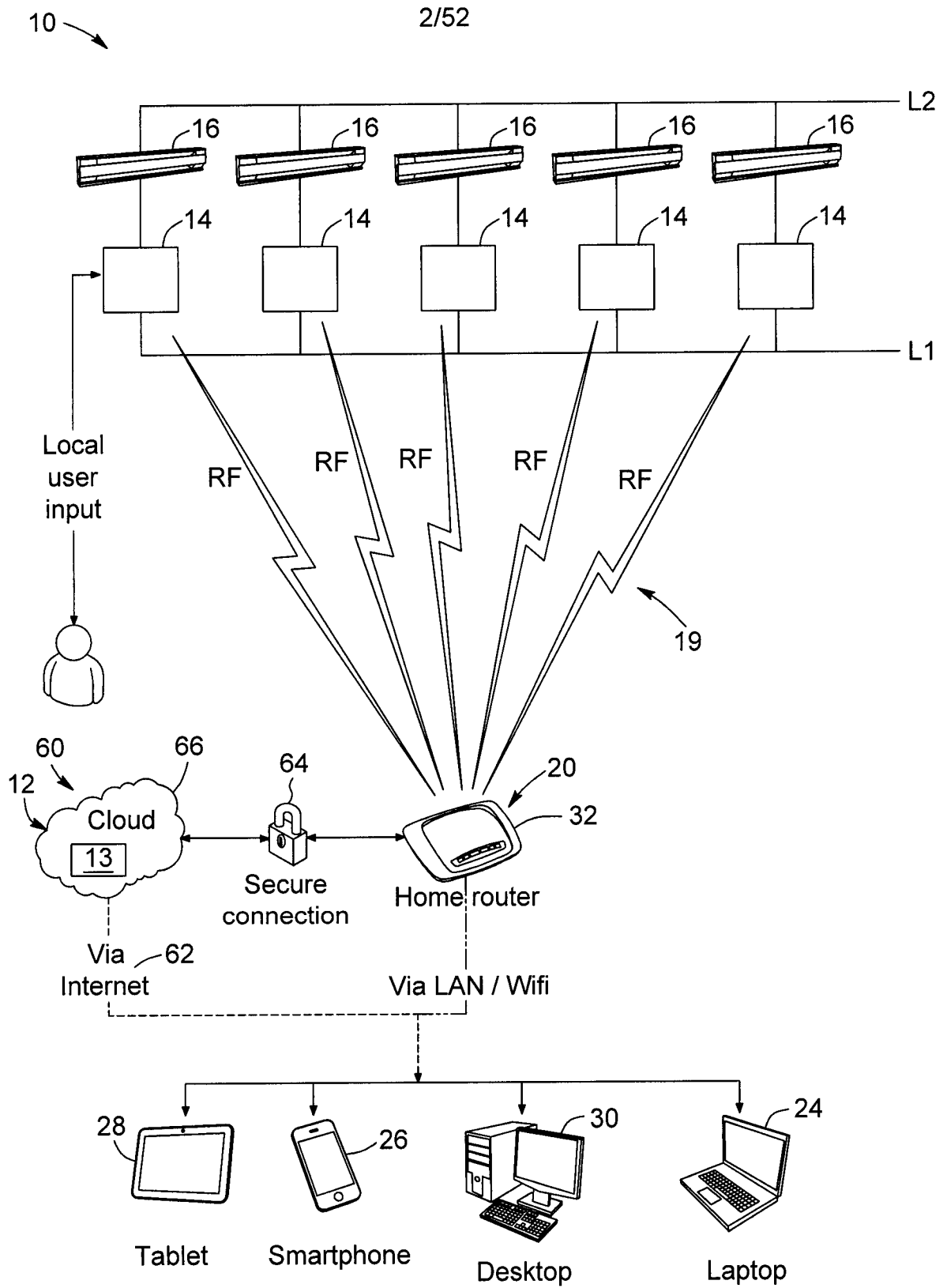

FIG. 2A

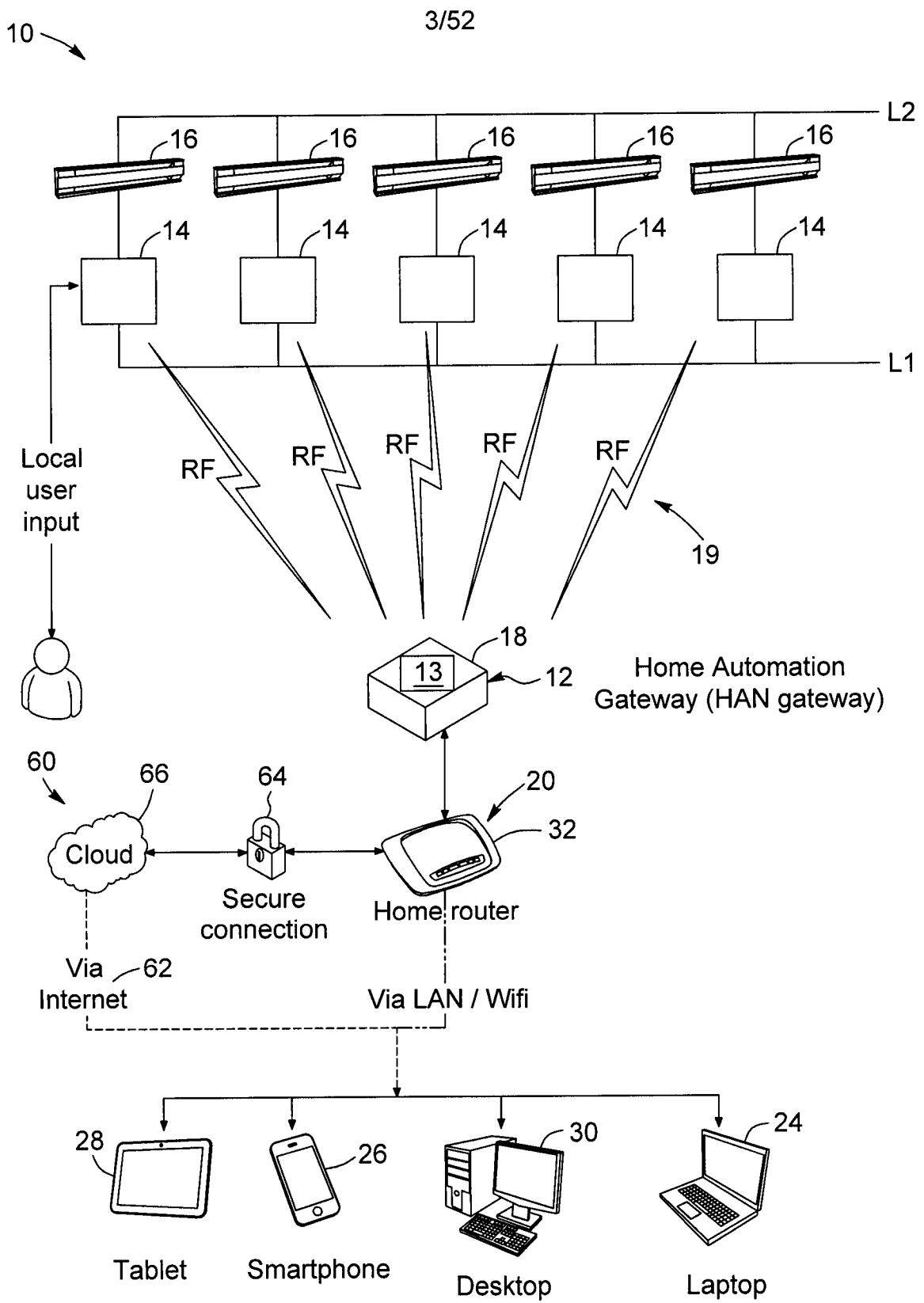

FIG. 2B

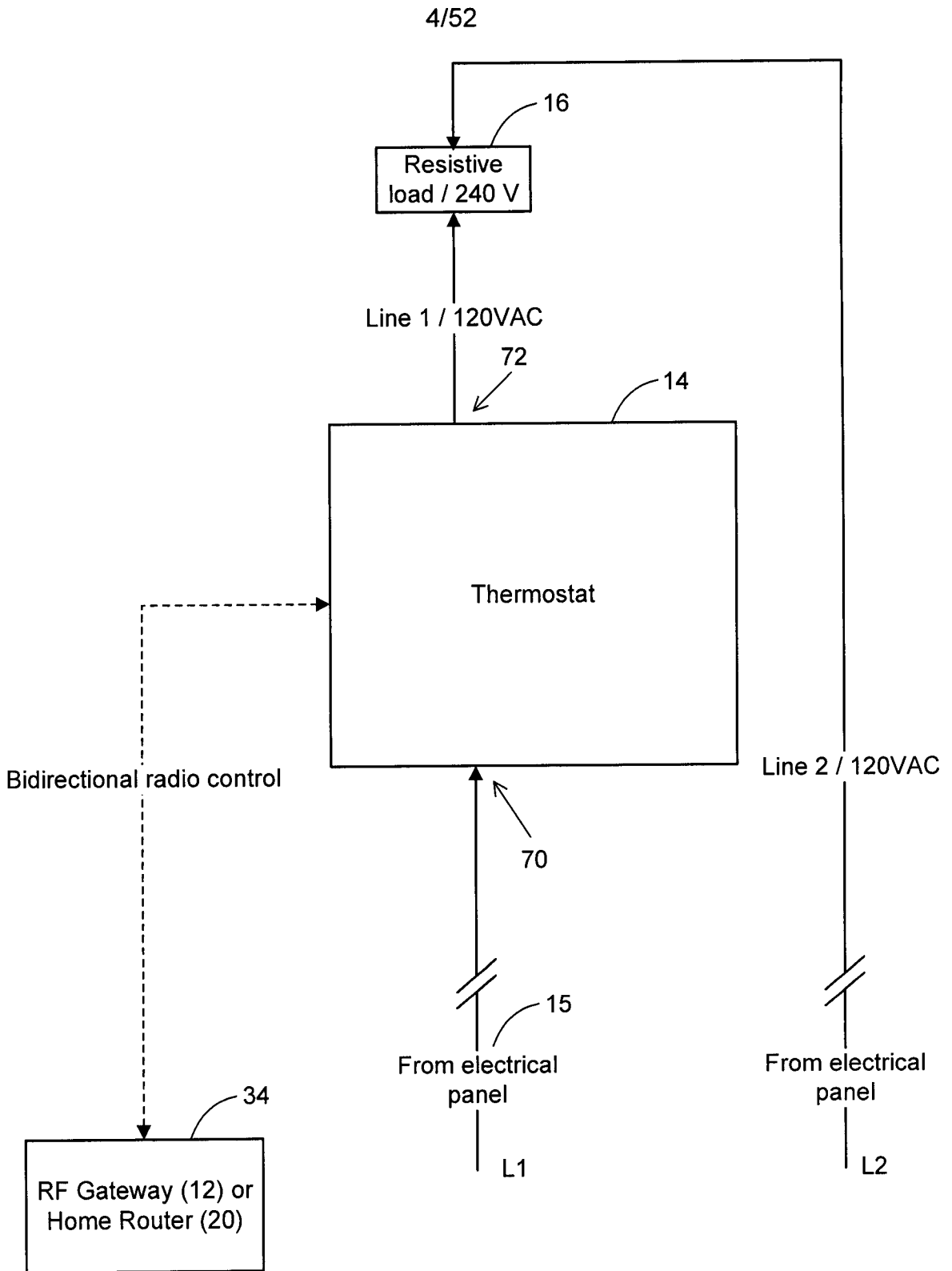

FIG. 3

5/52

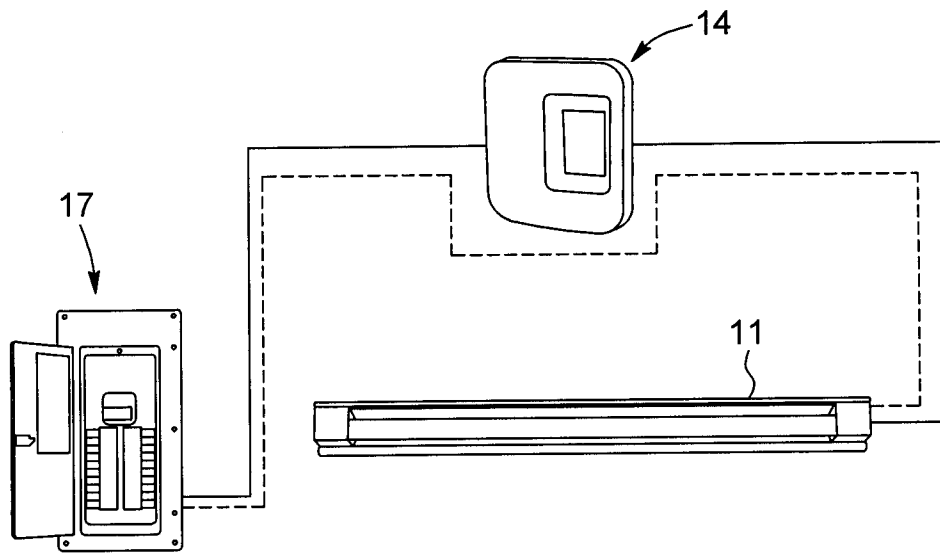

FIG. 4A

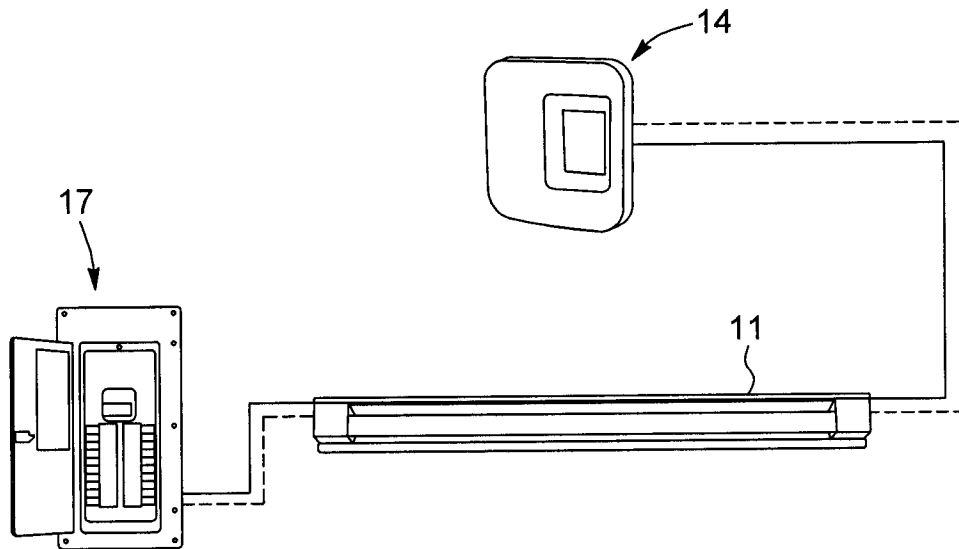

FIG. 4B

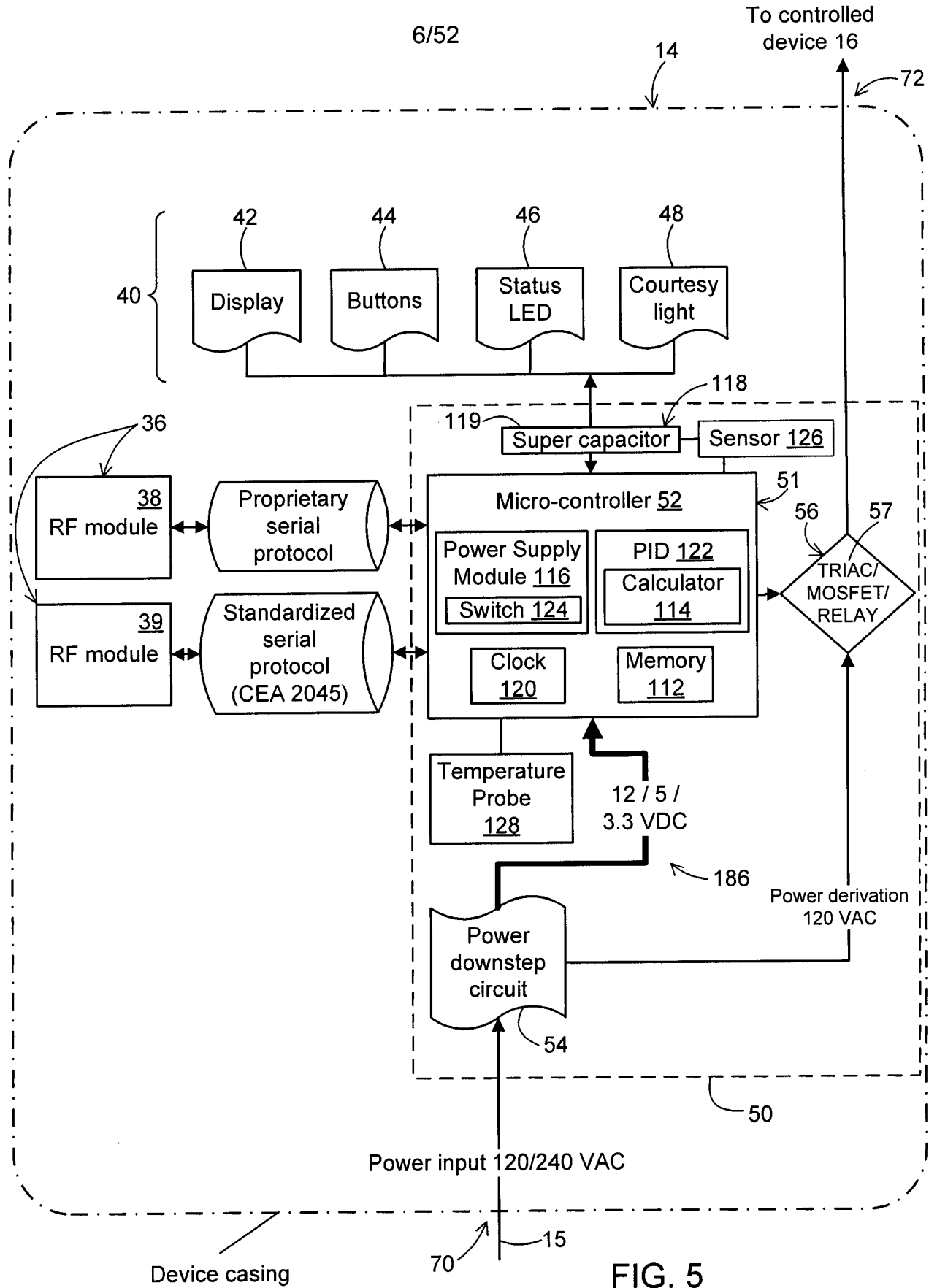

FIG. 5

7/52

200

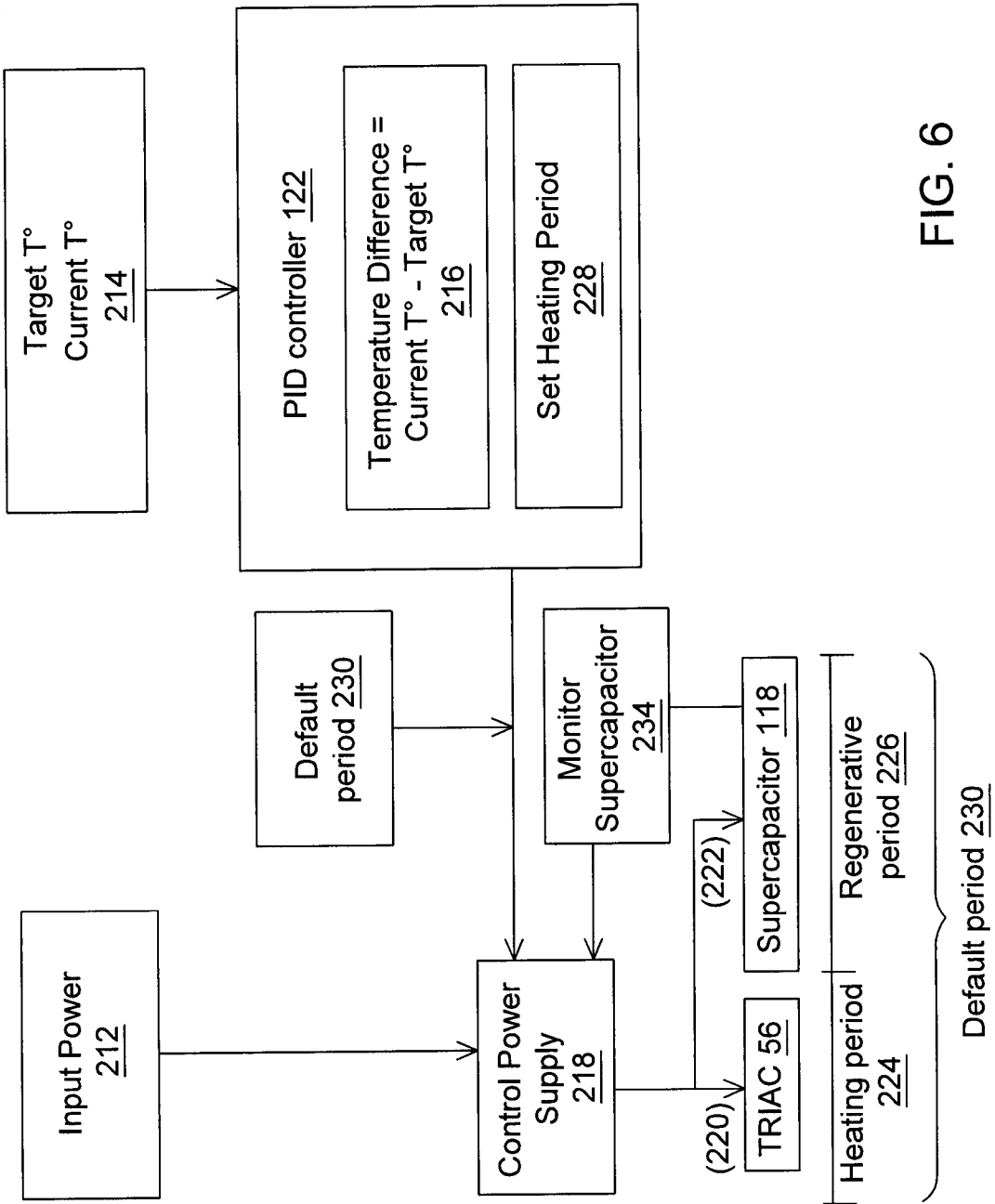

FIG. 6

150

CPU

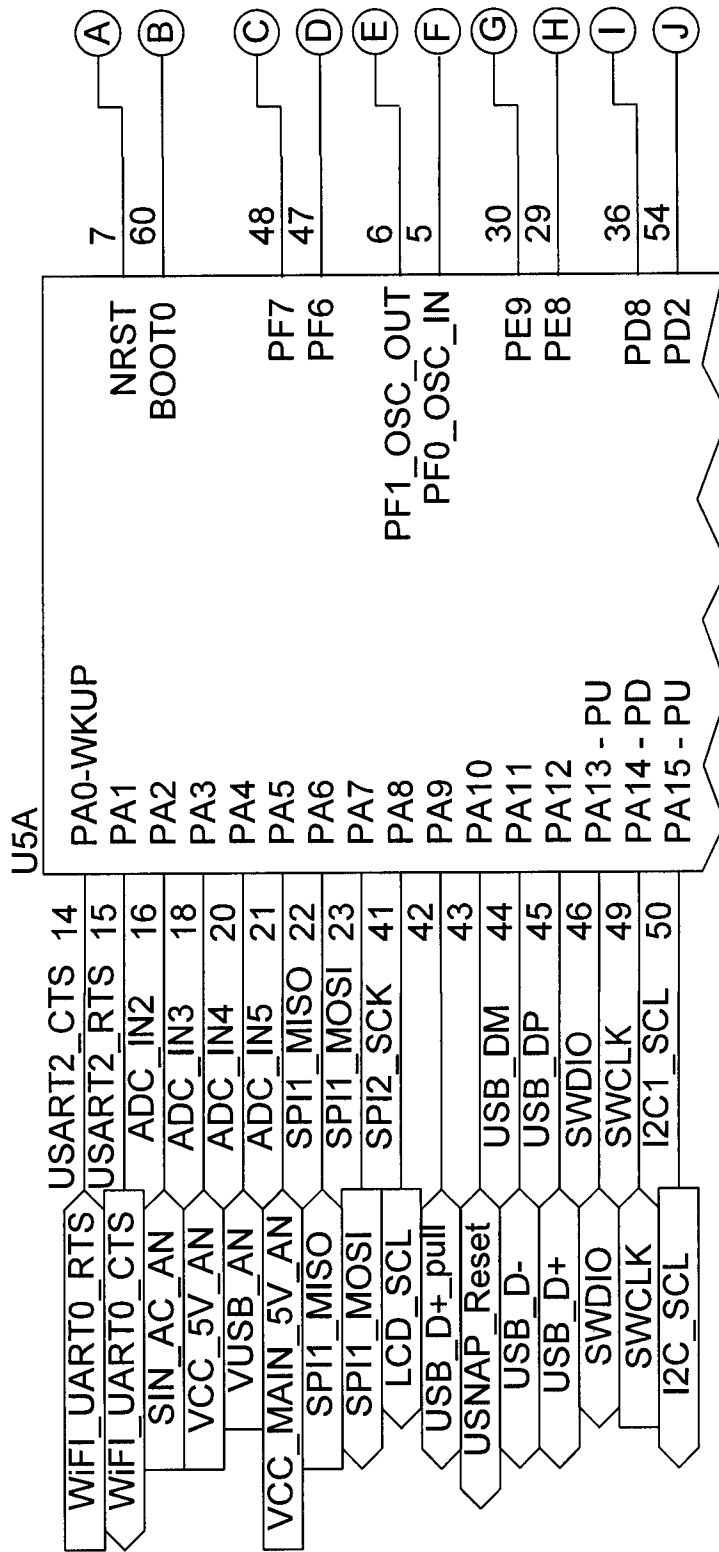

FIG. 7

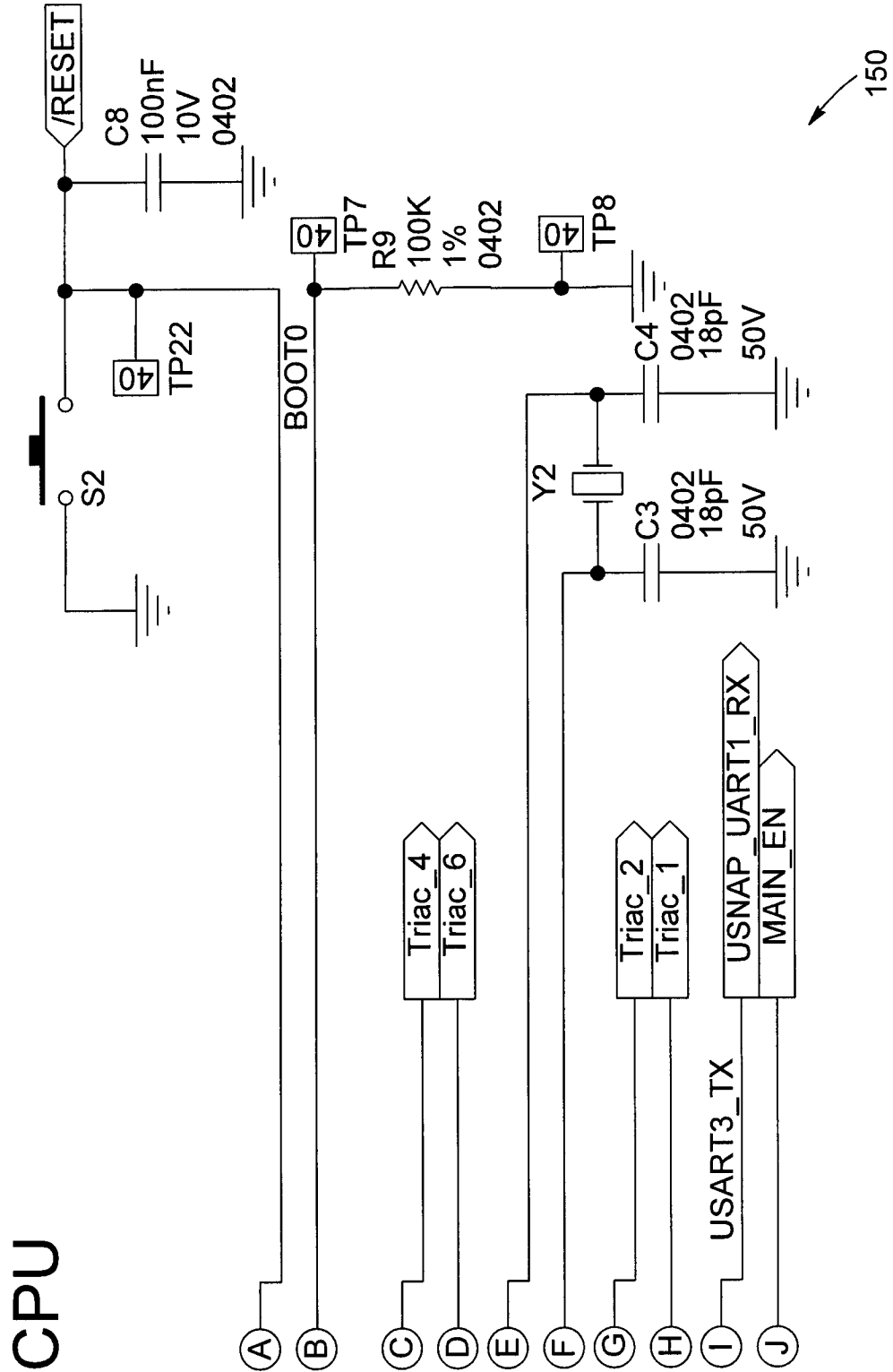

FIG. 7 continued

CPU

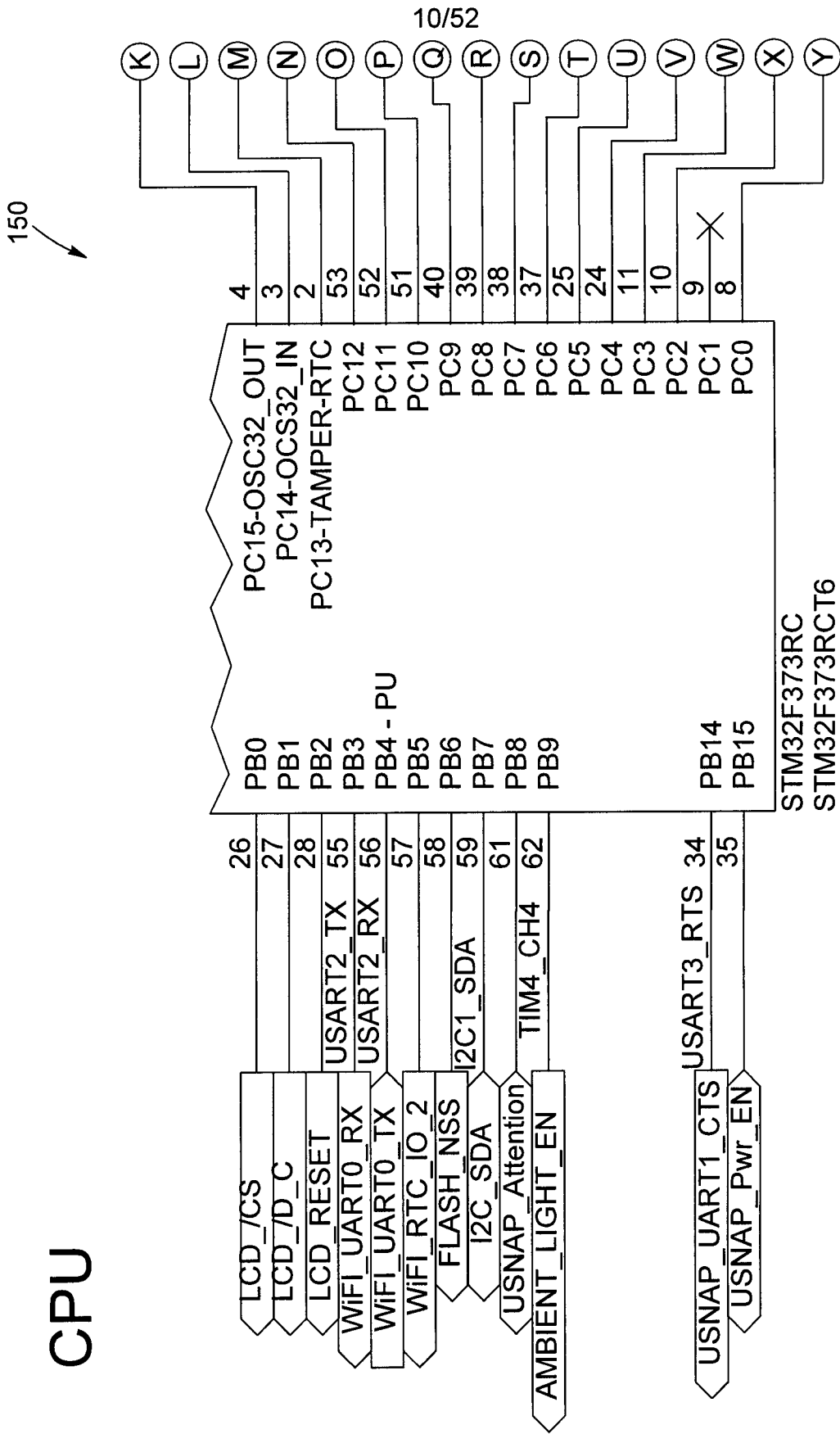

FIG. 7 continued

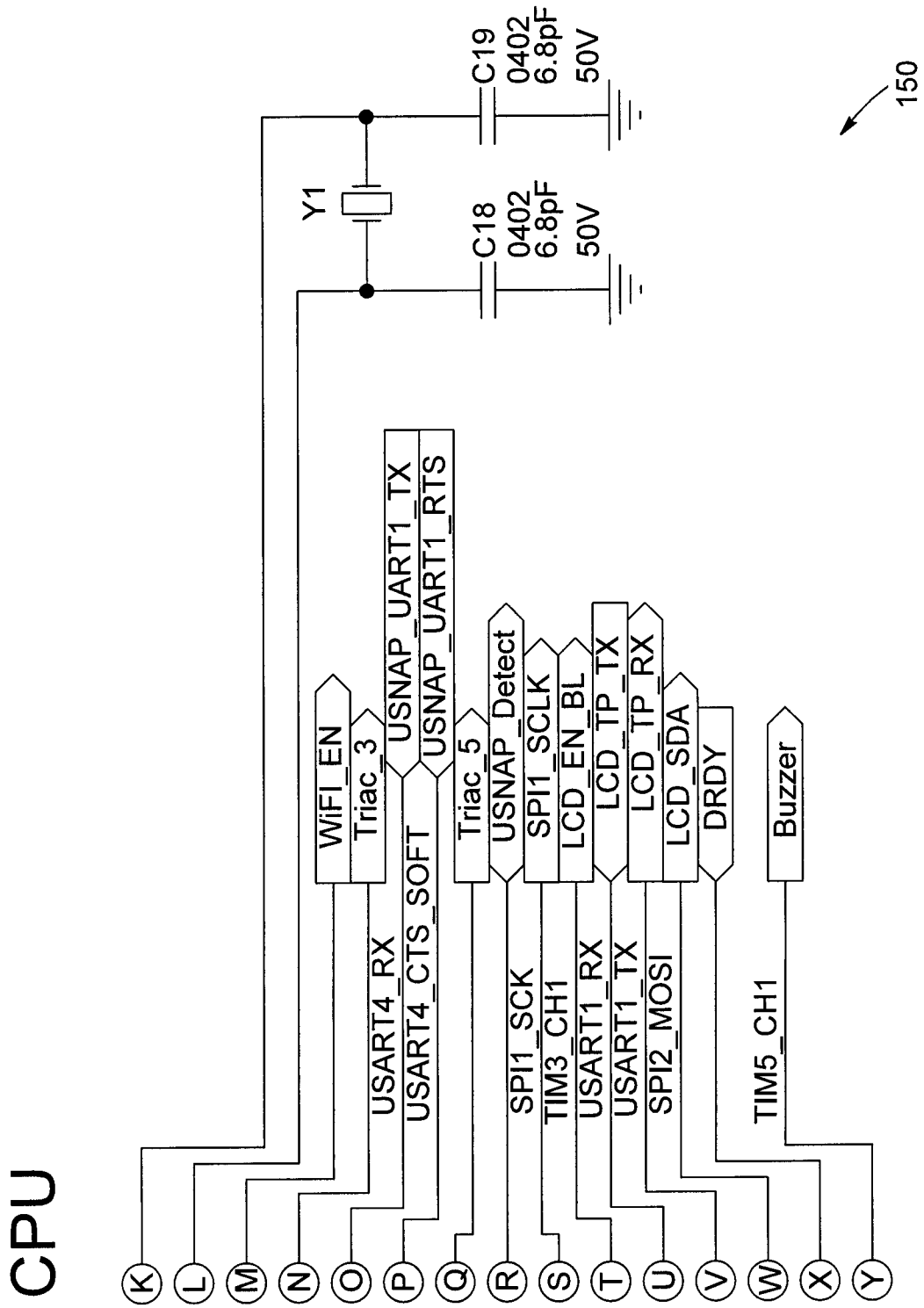

FIG. 7 continued

Flash 16MBits

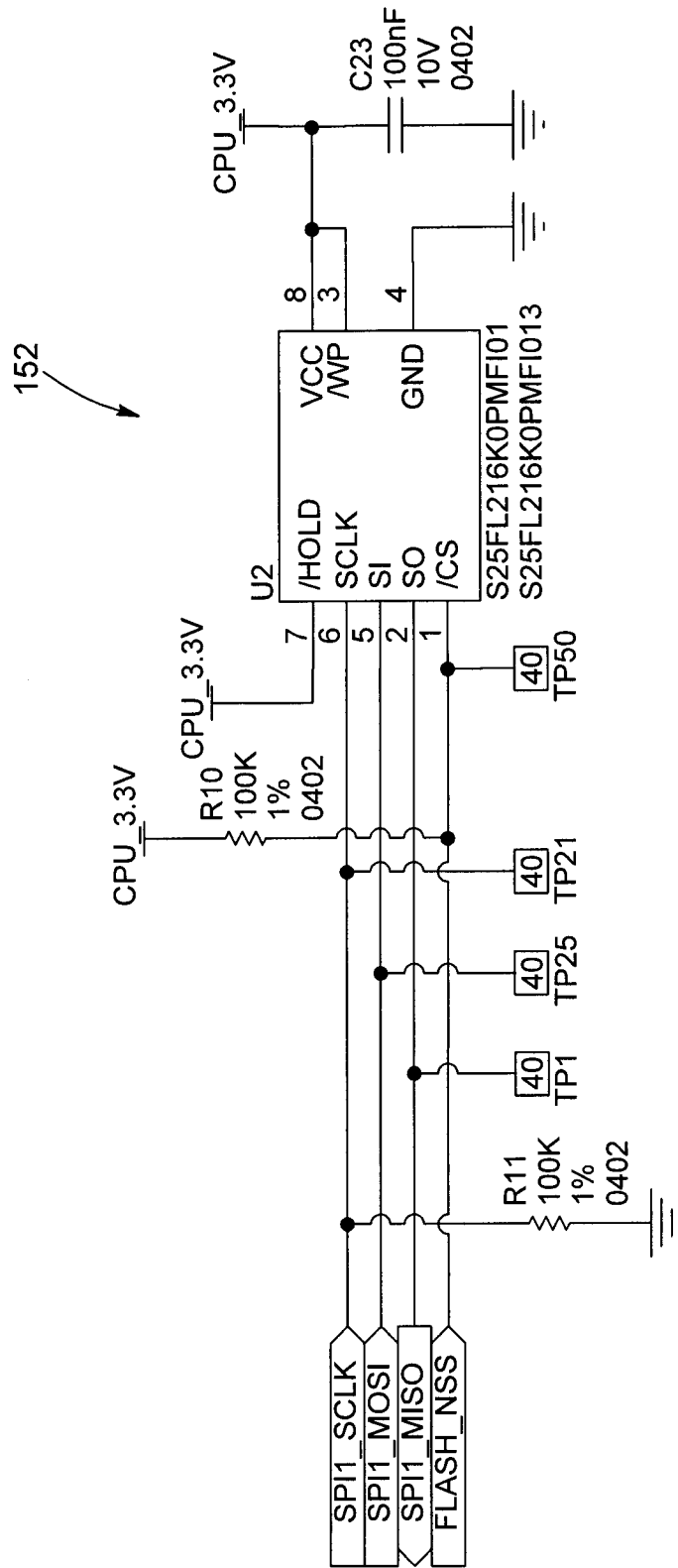

FIG. 8

CPU LDO

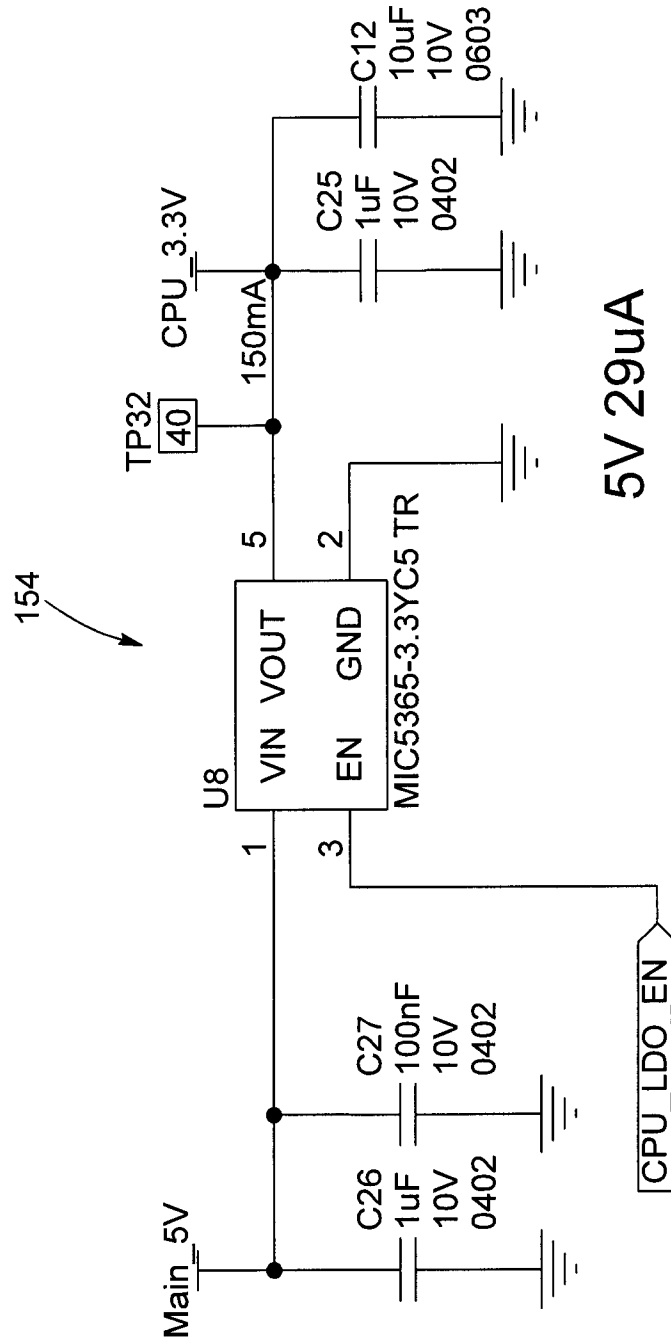

FIG. 9

SWD

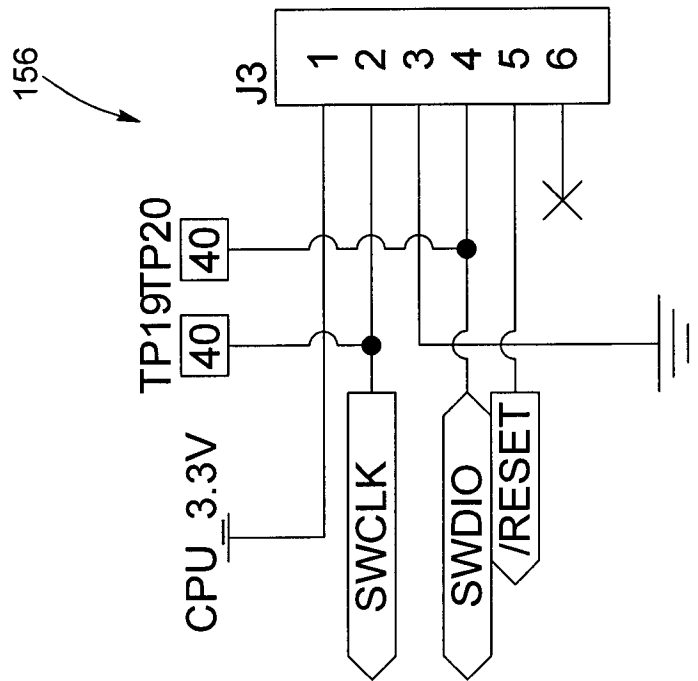
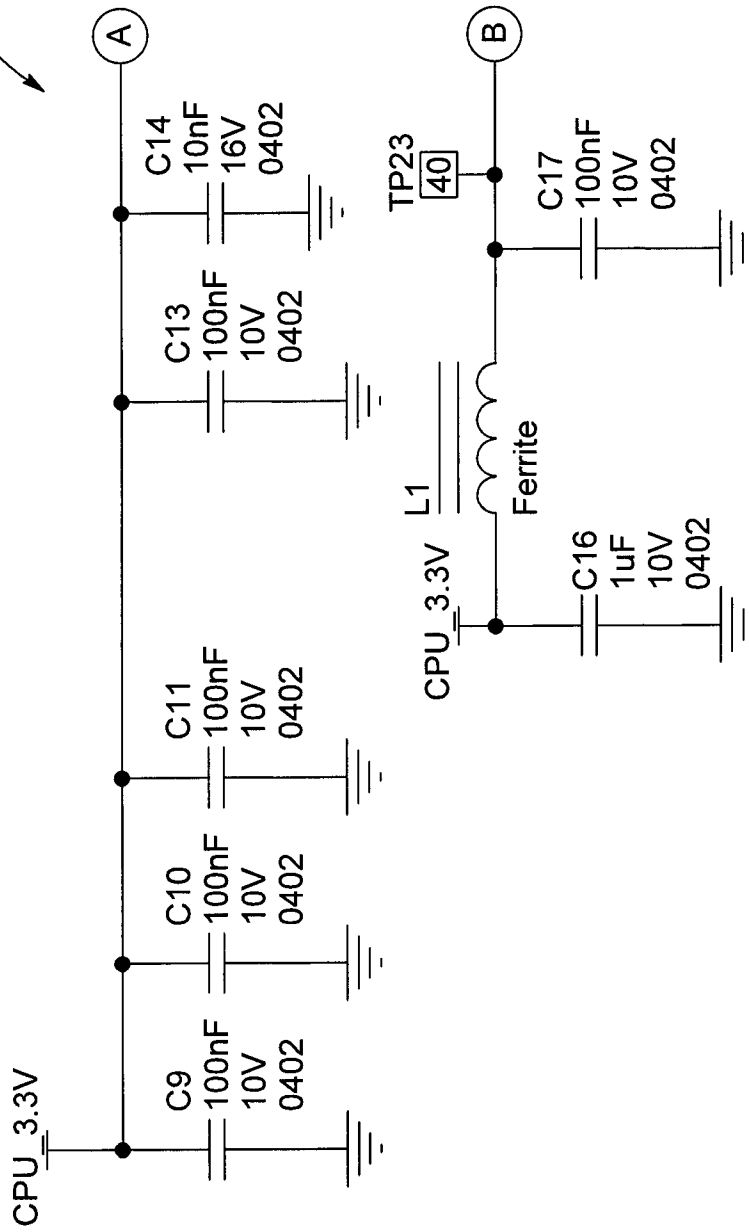

FIG. 10

CPU Supply & Decoupling

158



Full RUN (32MHz): 3.3V 10mA, RTC Mode: 3.3V 1.5uA

FIG. 11

CPU Supply & Decoupling

158

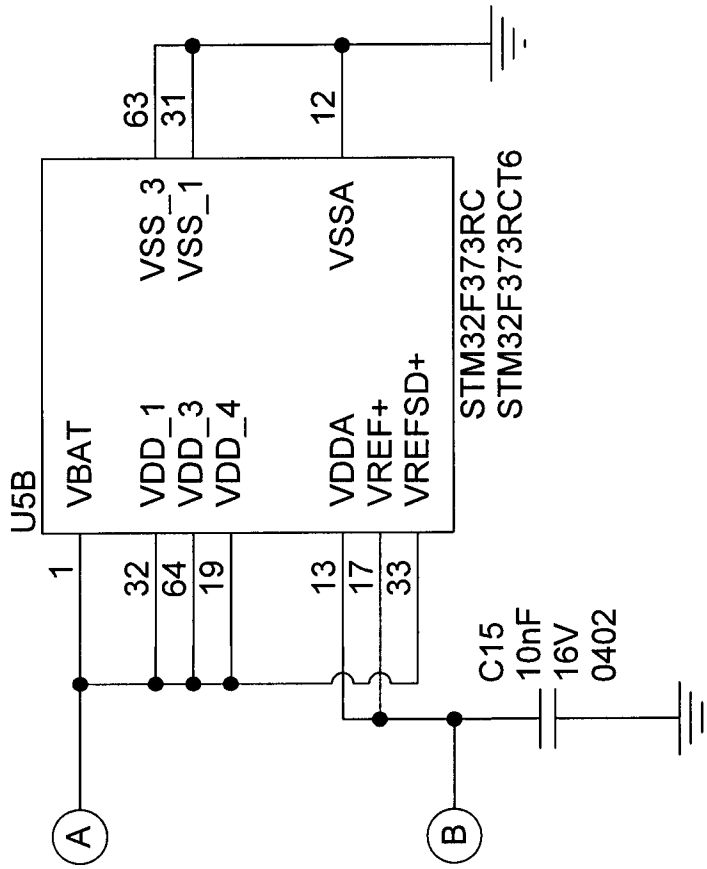

Full RUN (32MHz): 3.3V 10mA, RTC Mode: 3.3V 1.5uA

FIG. 11 continued

Temperature and Humidity Sensor

160

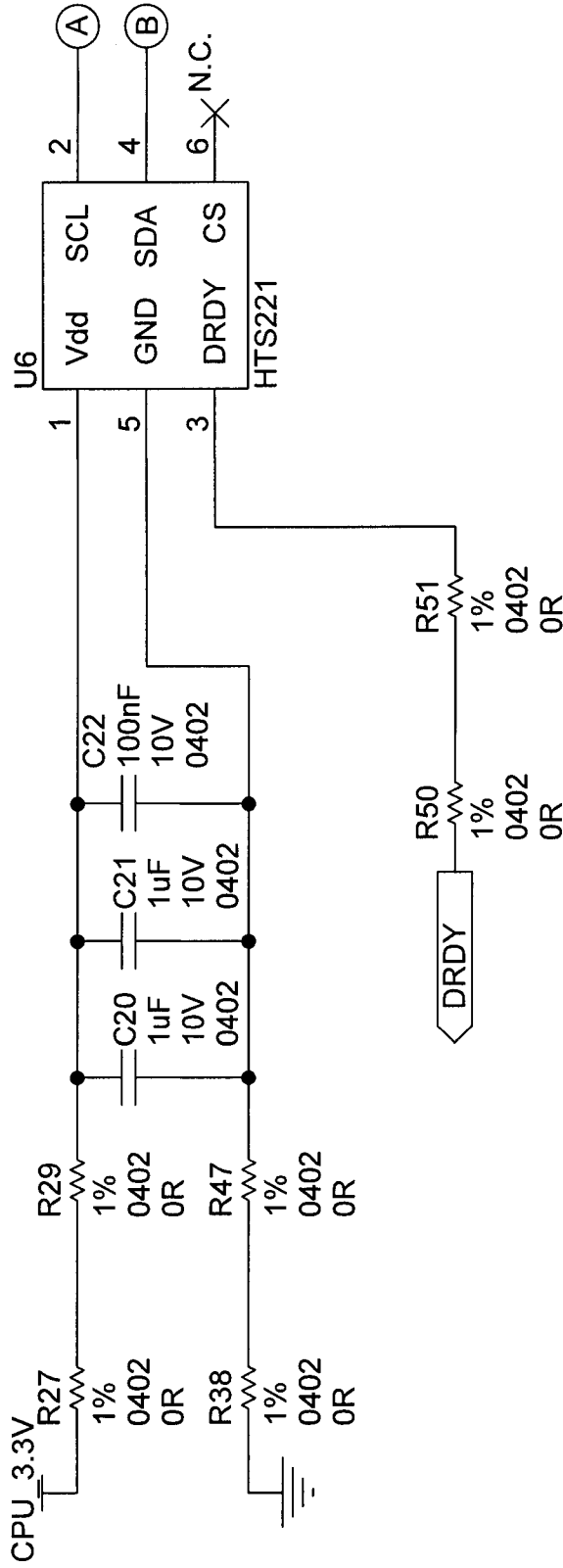

3.3V 20uA, +/-4% Humidity and +/-0.5C

FIG. 12

Temperature and Humidity Sensor

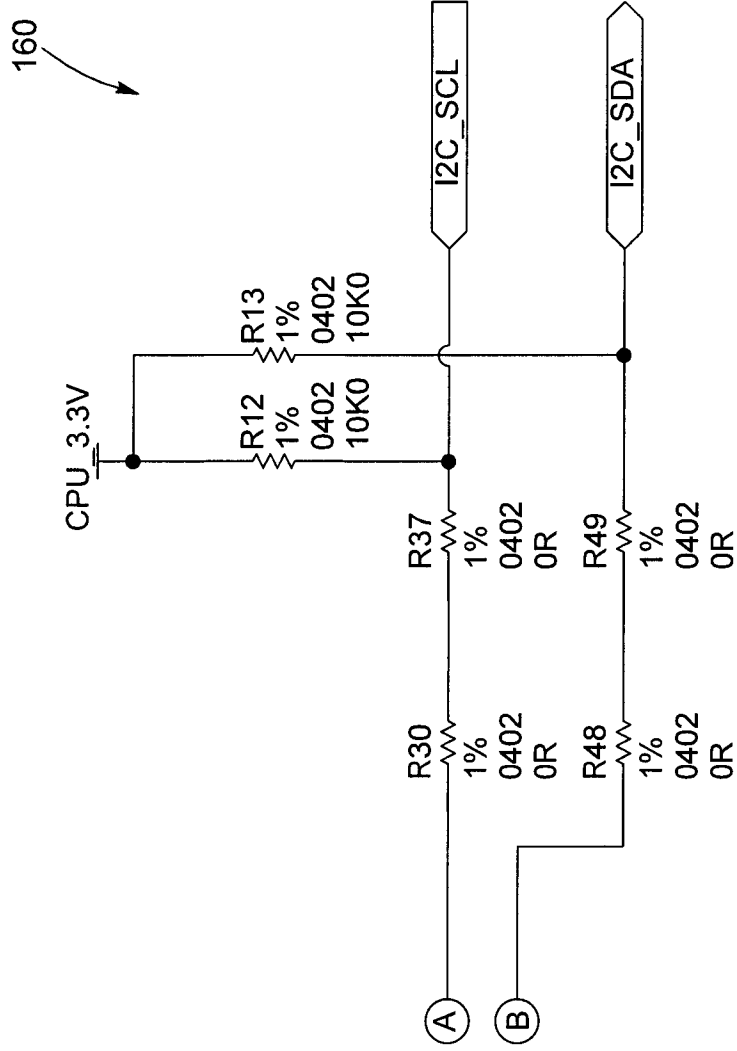

3.3V 20uA, +/-4% Humidity and +/- 0.5C

FIG. 12 continued

Ambient Light Control

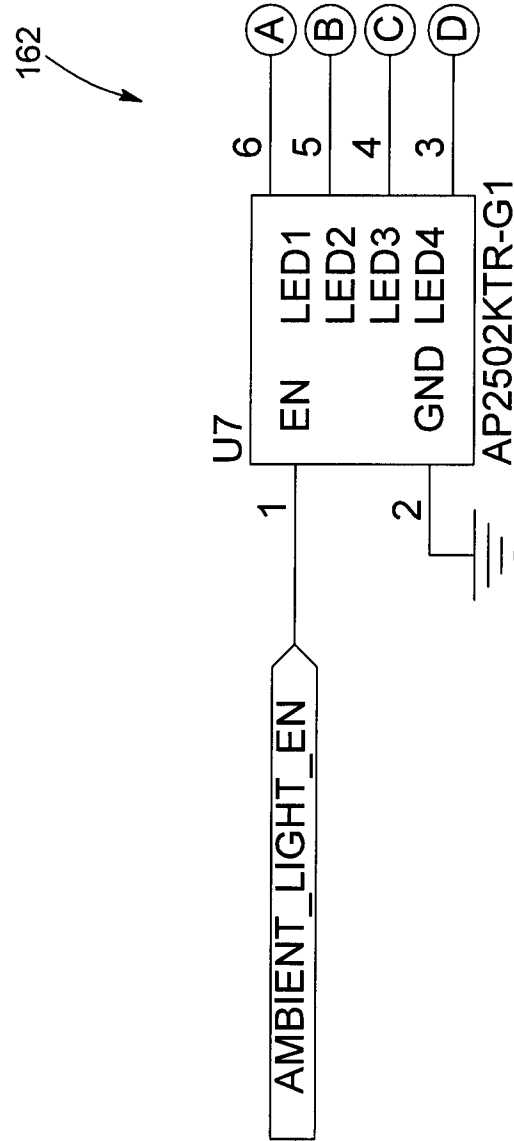

FIG. 13

Ambient Light Control

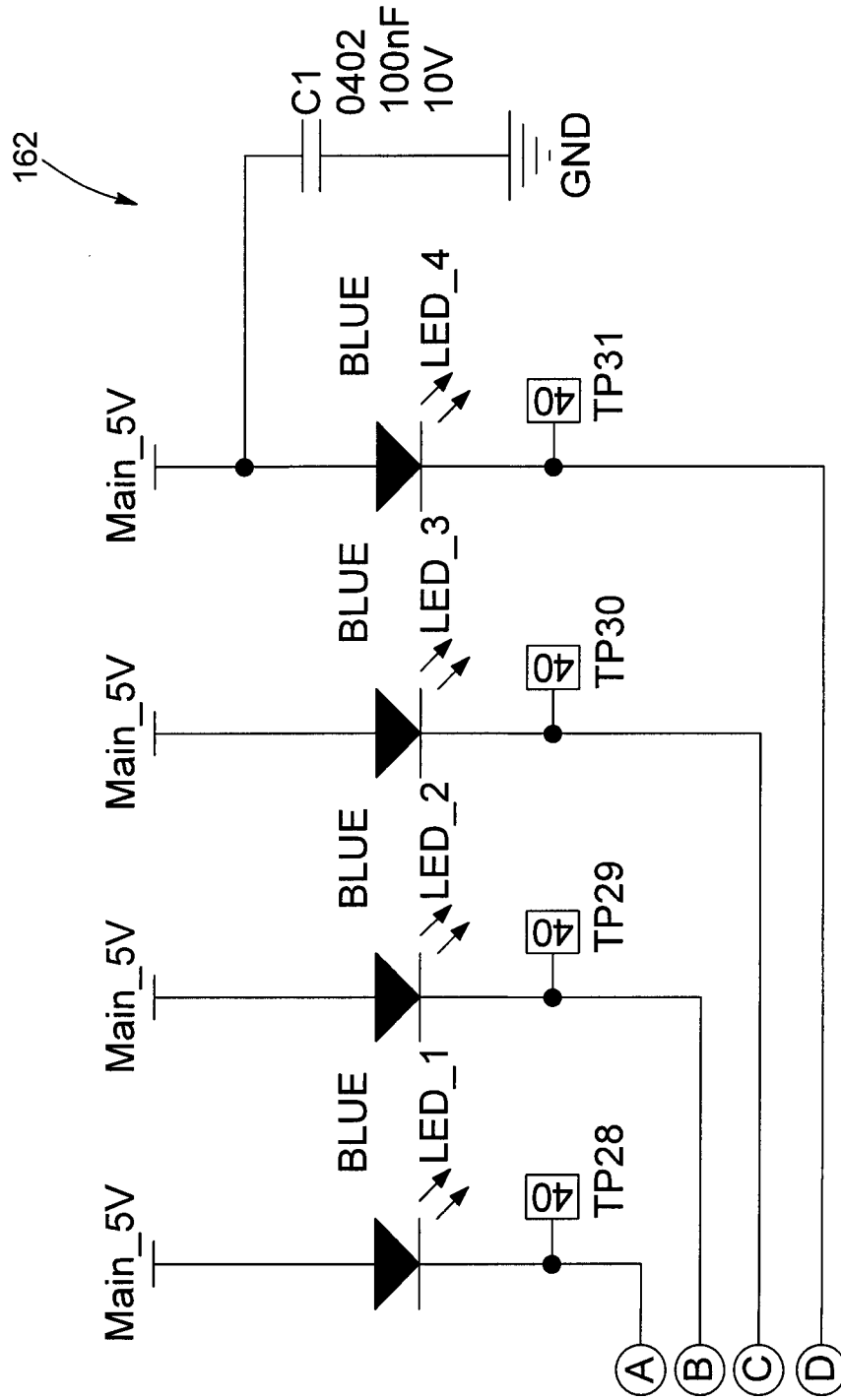
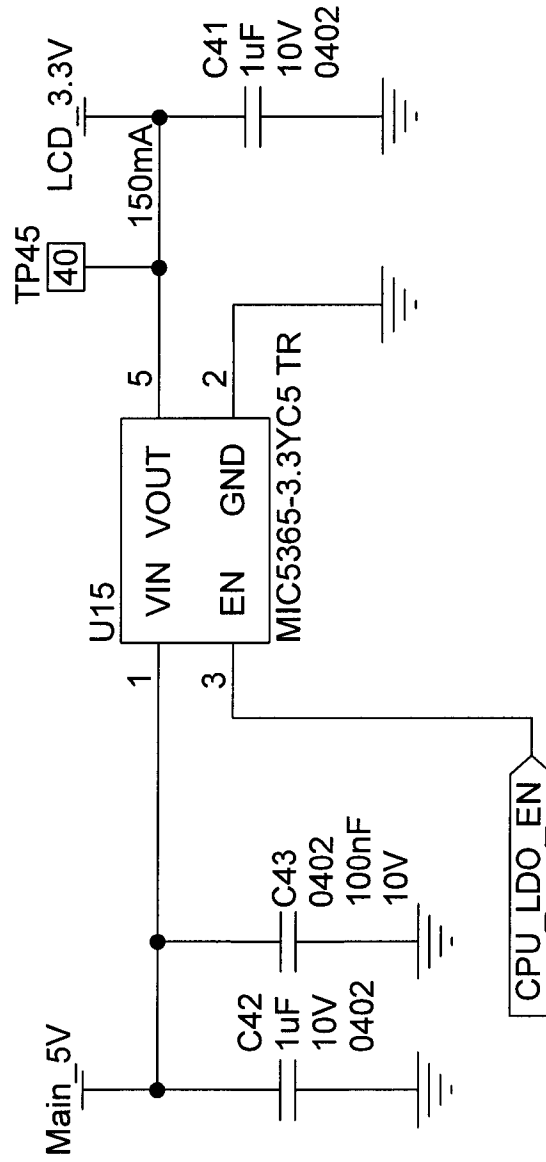

FIG. 13 continued

LCD LDO

164



5V 29uA

FIG. 14

LCD BackLight Control

166

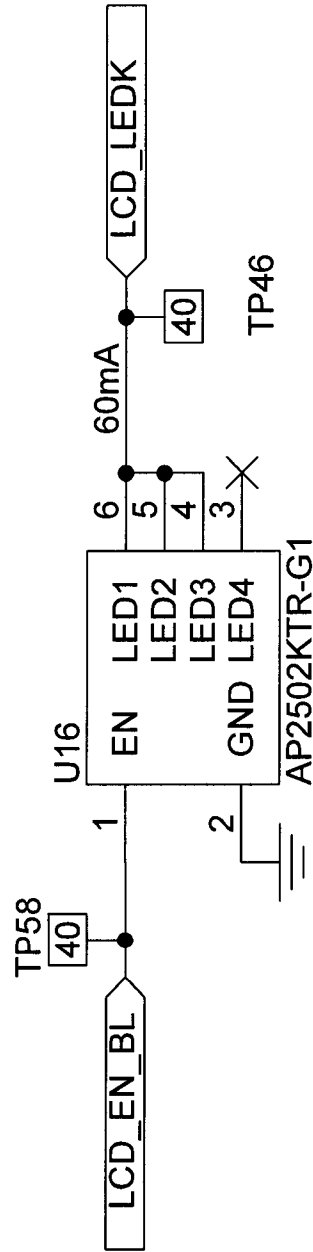

FIG. 15

168

LCD TouchScreen Controller

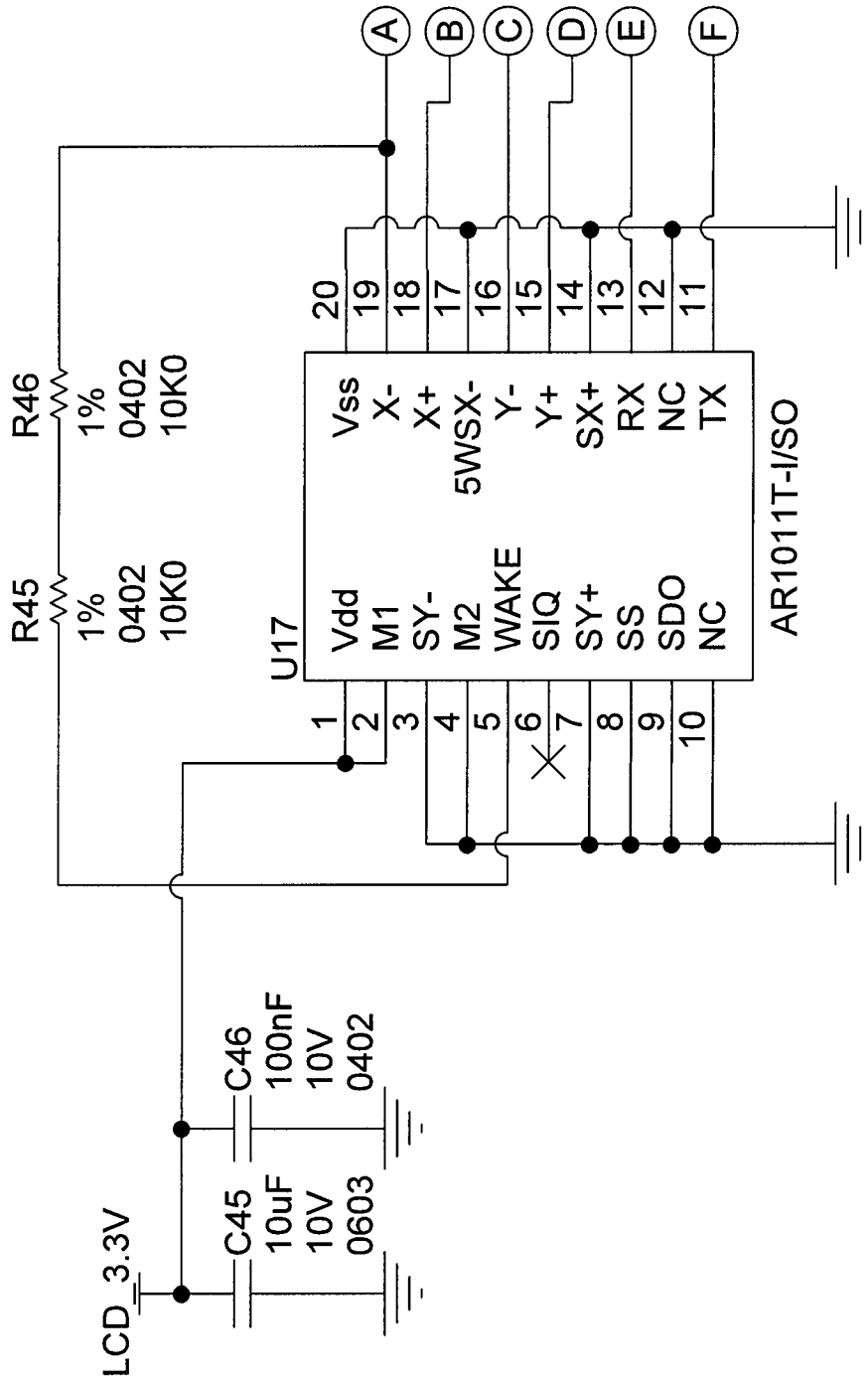

FIG. 16

24/52

LCD TouchScreen Controller

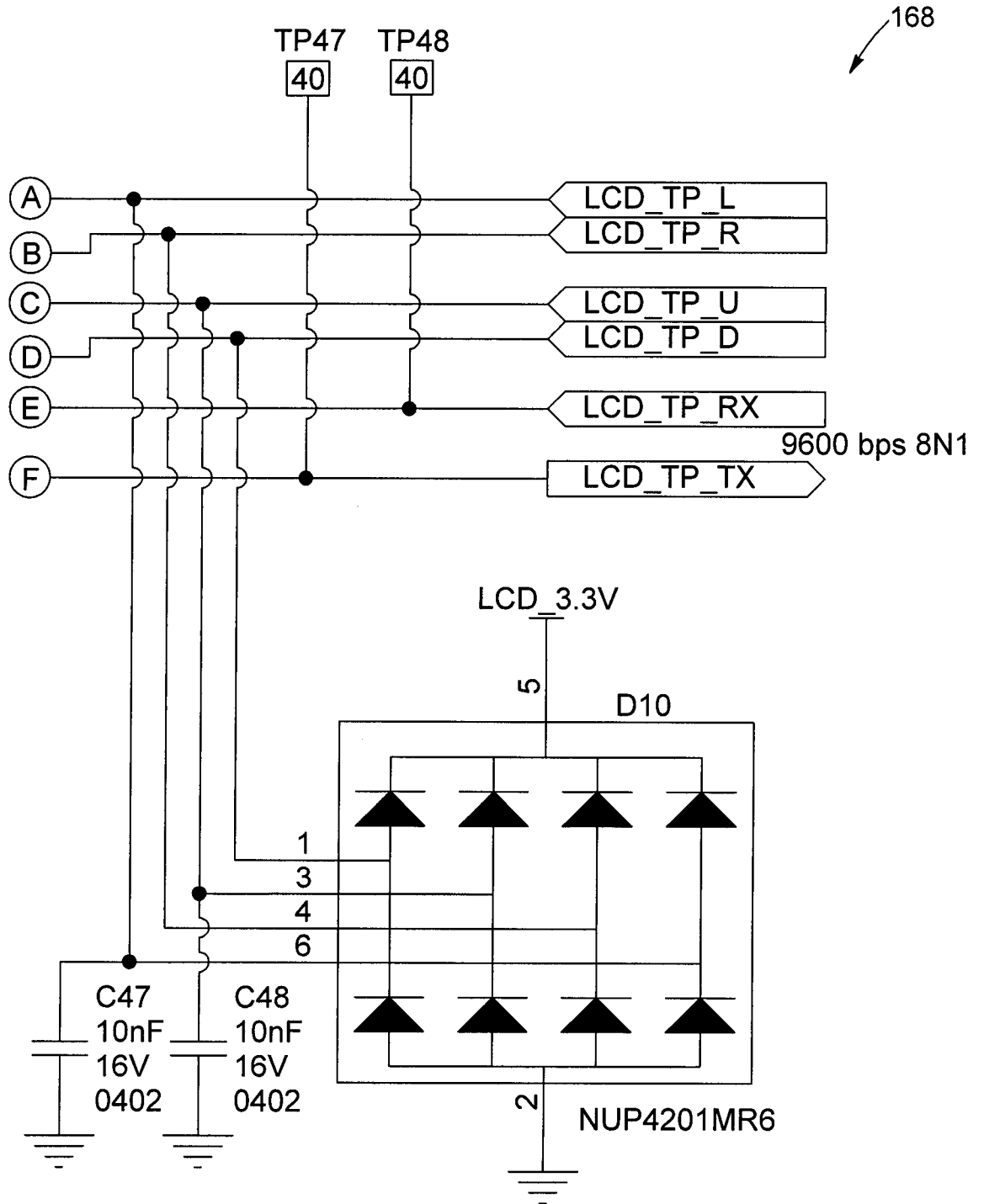

FIG. 16 continued

25/52

LCD

170

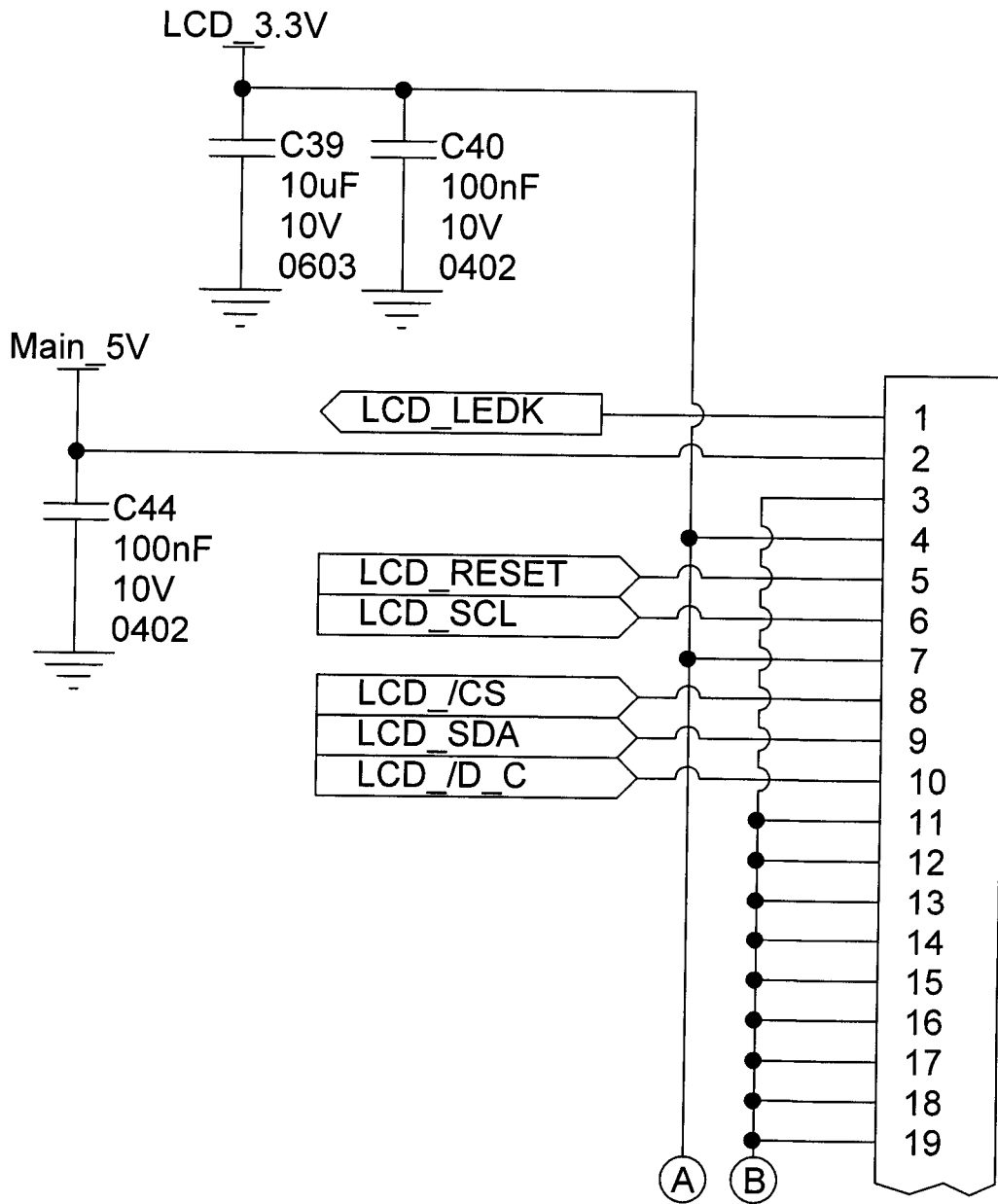

FIG. 17

LCD

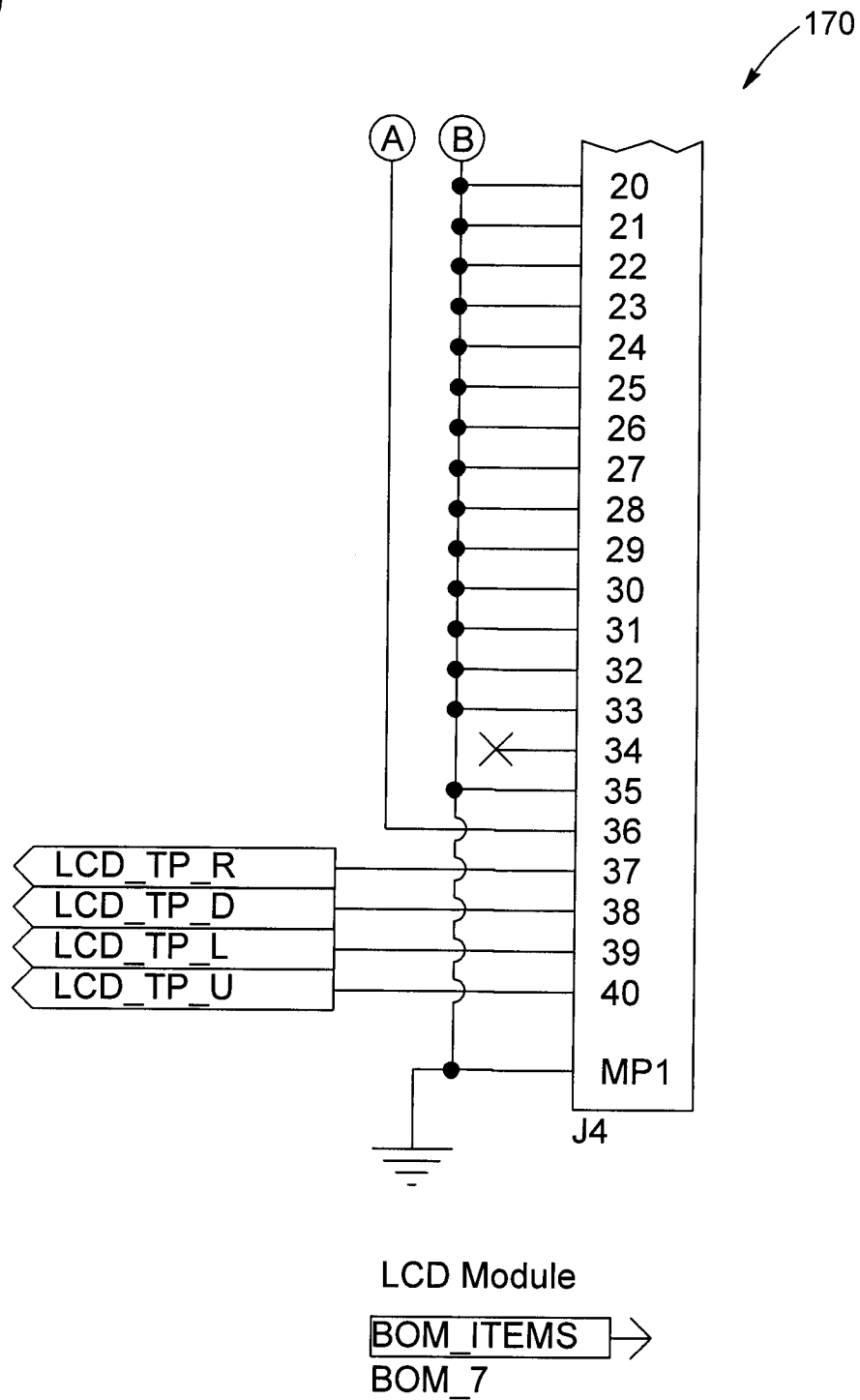

FIG. 17 continued

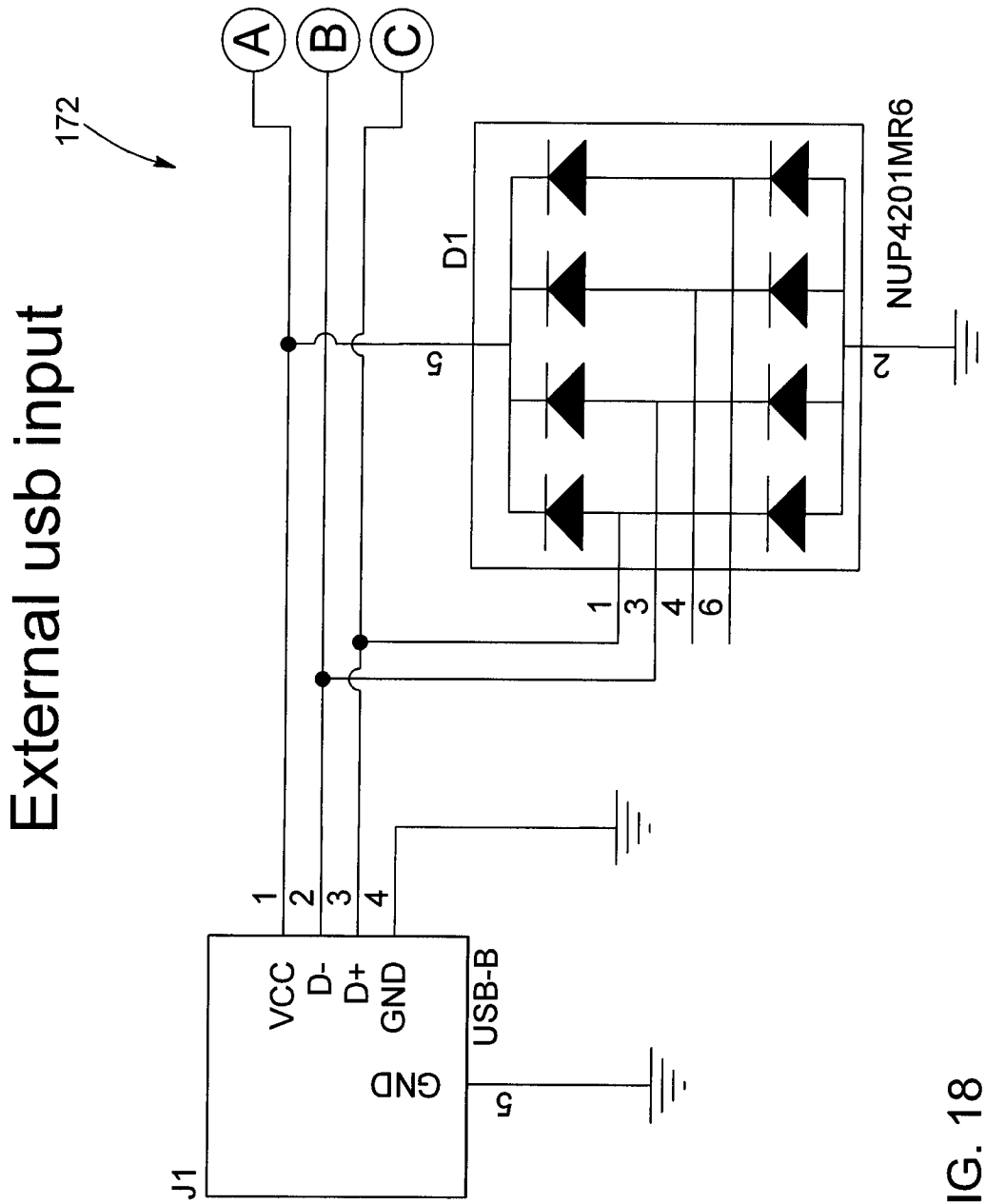

FIG. 18

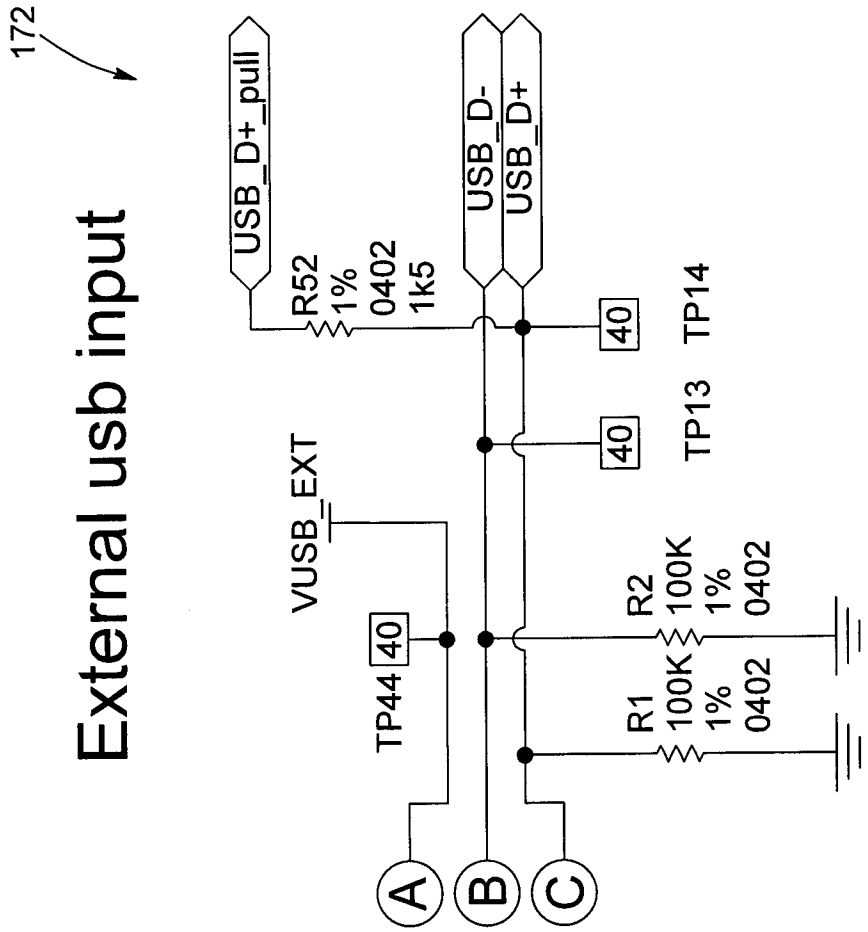

FIG. 18 continued

U_SNAP Connector adapter

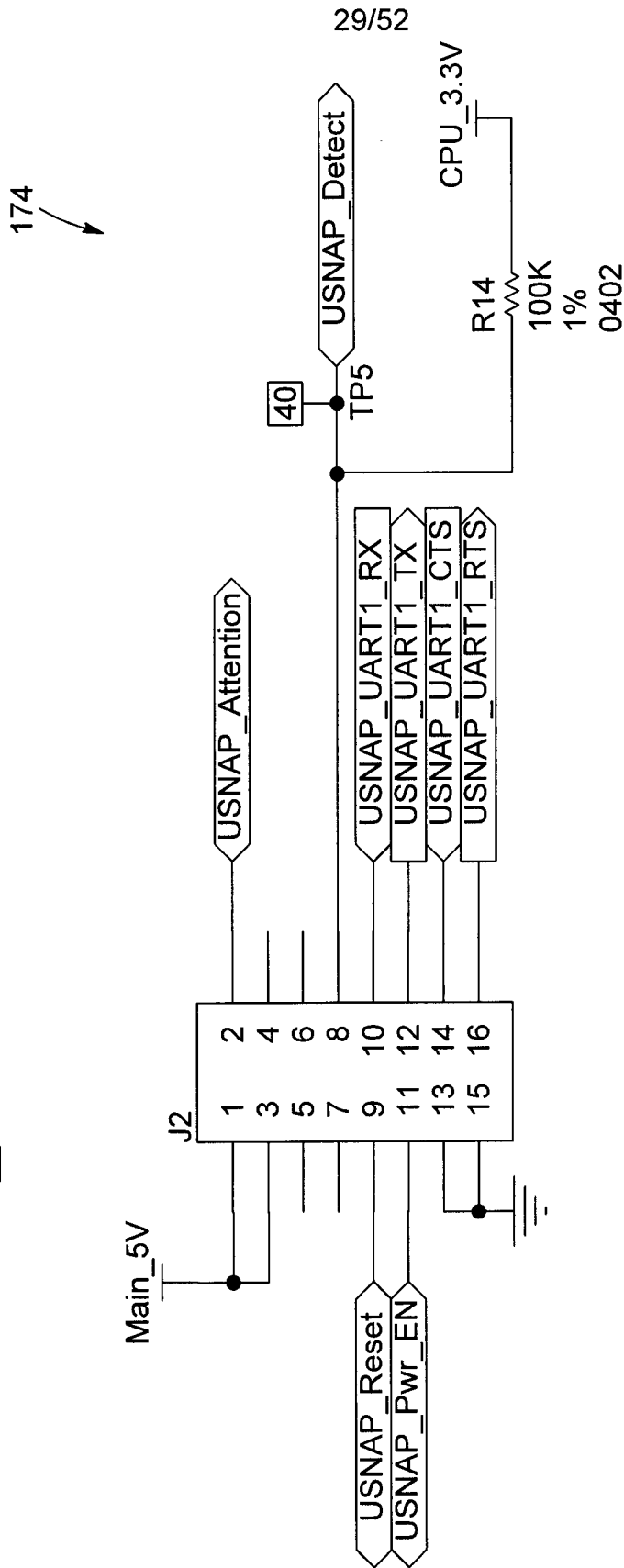

FIG. 19

U_SNAP Connector adapter

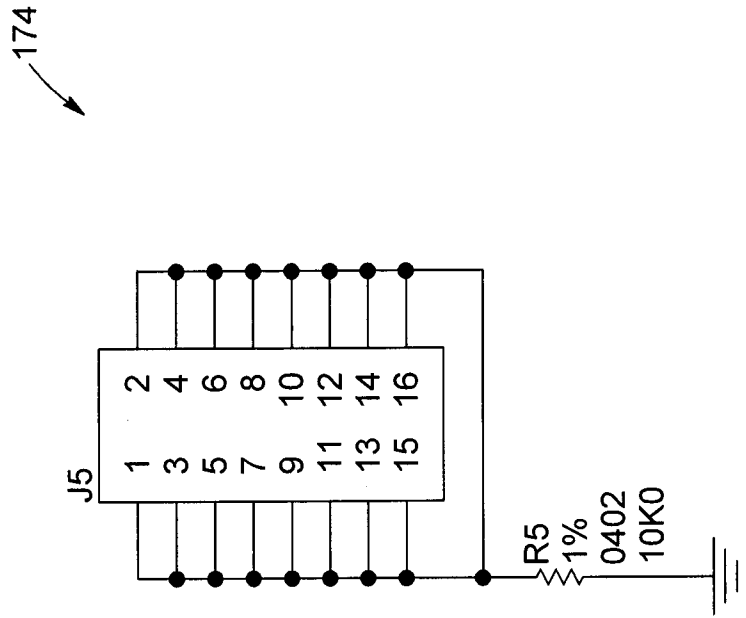

FIG. 19 continued

Buzzer

176

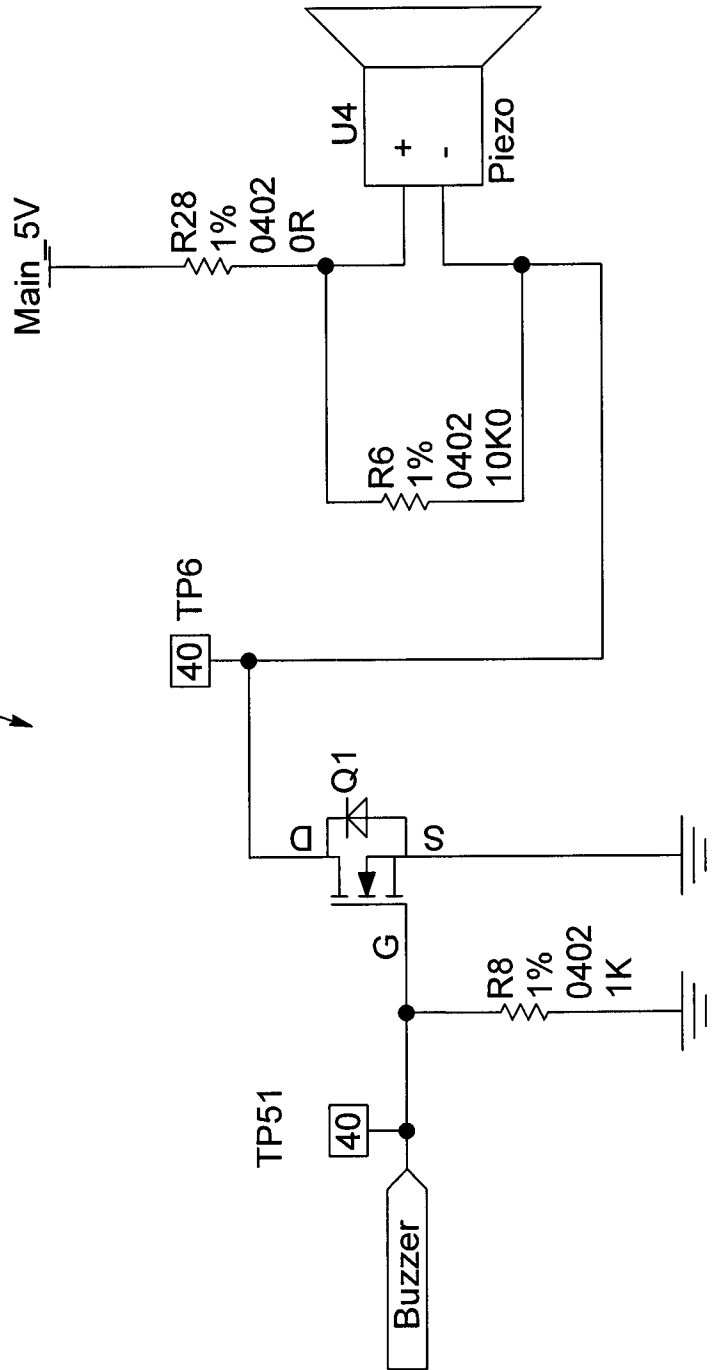

FIG. 20

WiFi

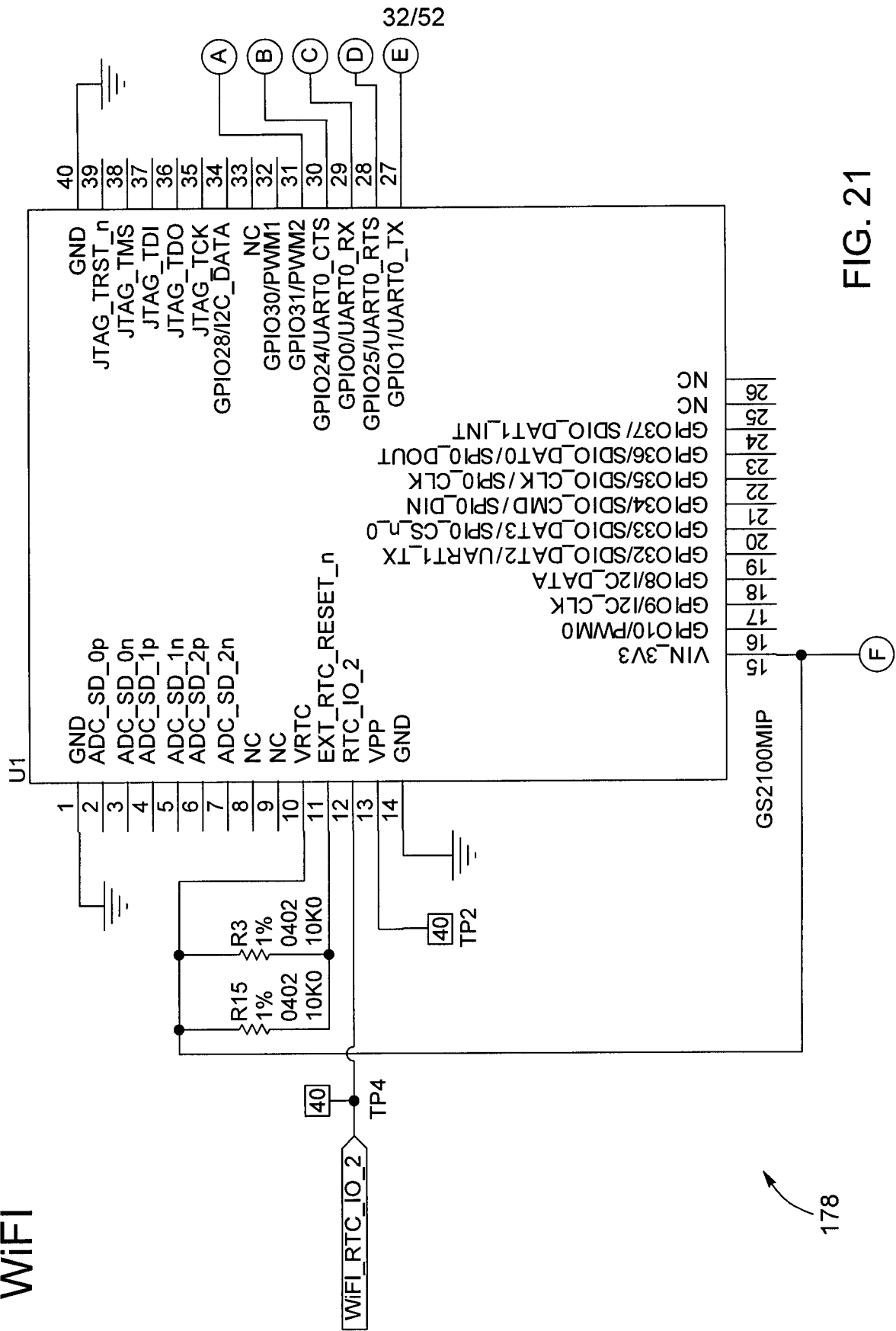
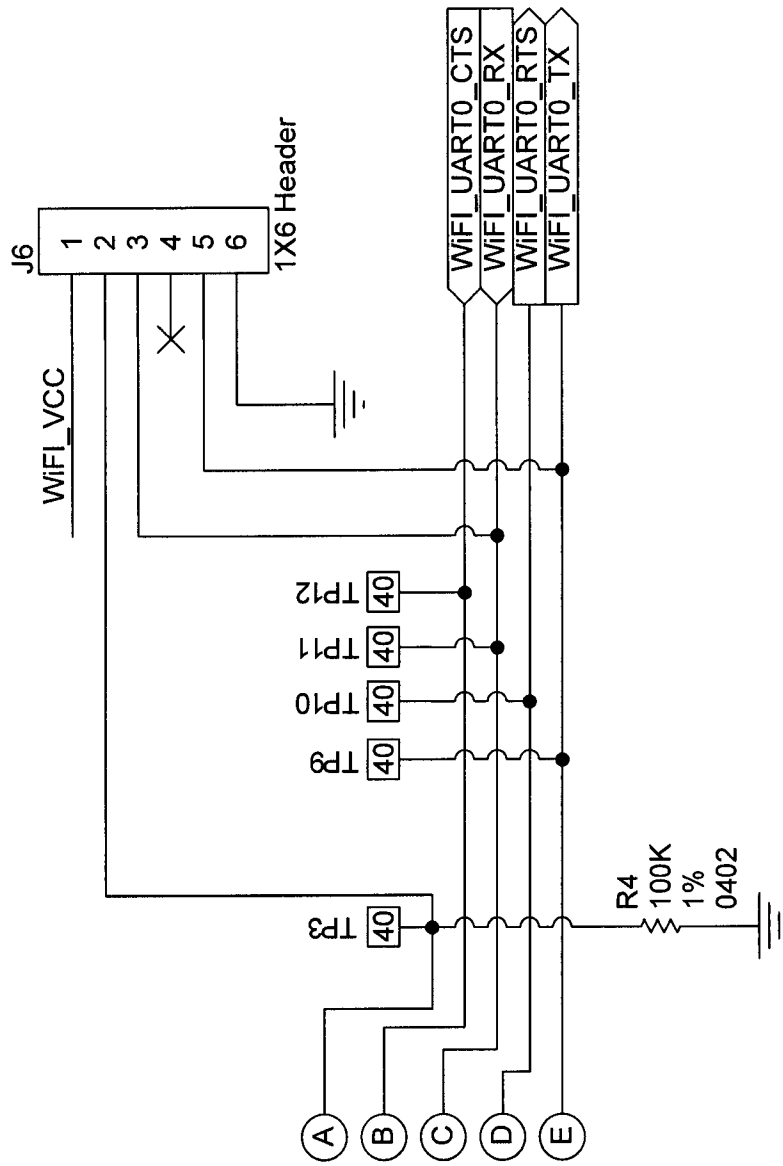

FIG. 21

WiFi



178

FIG. 21 continued

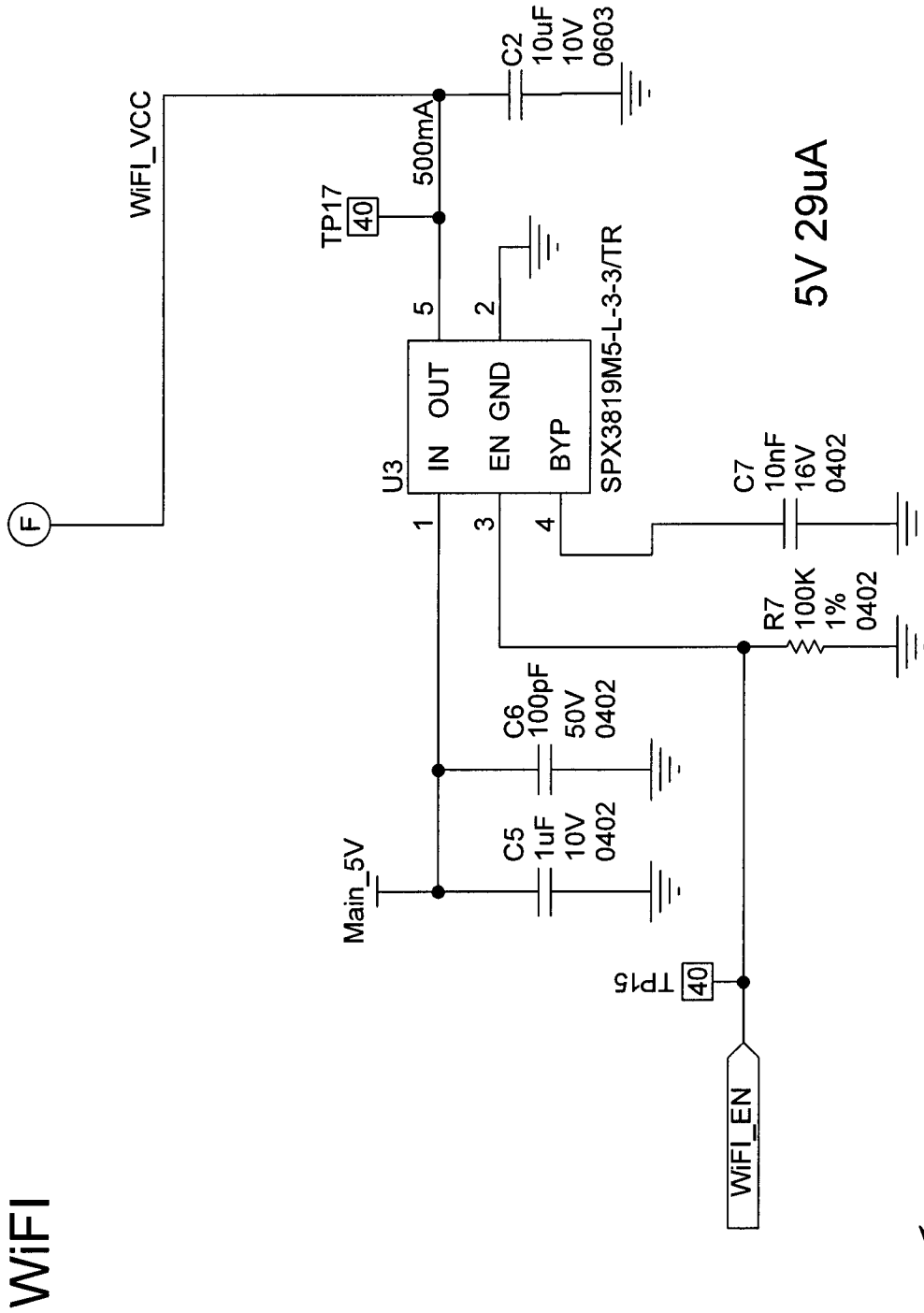
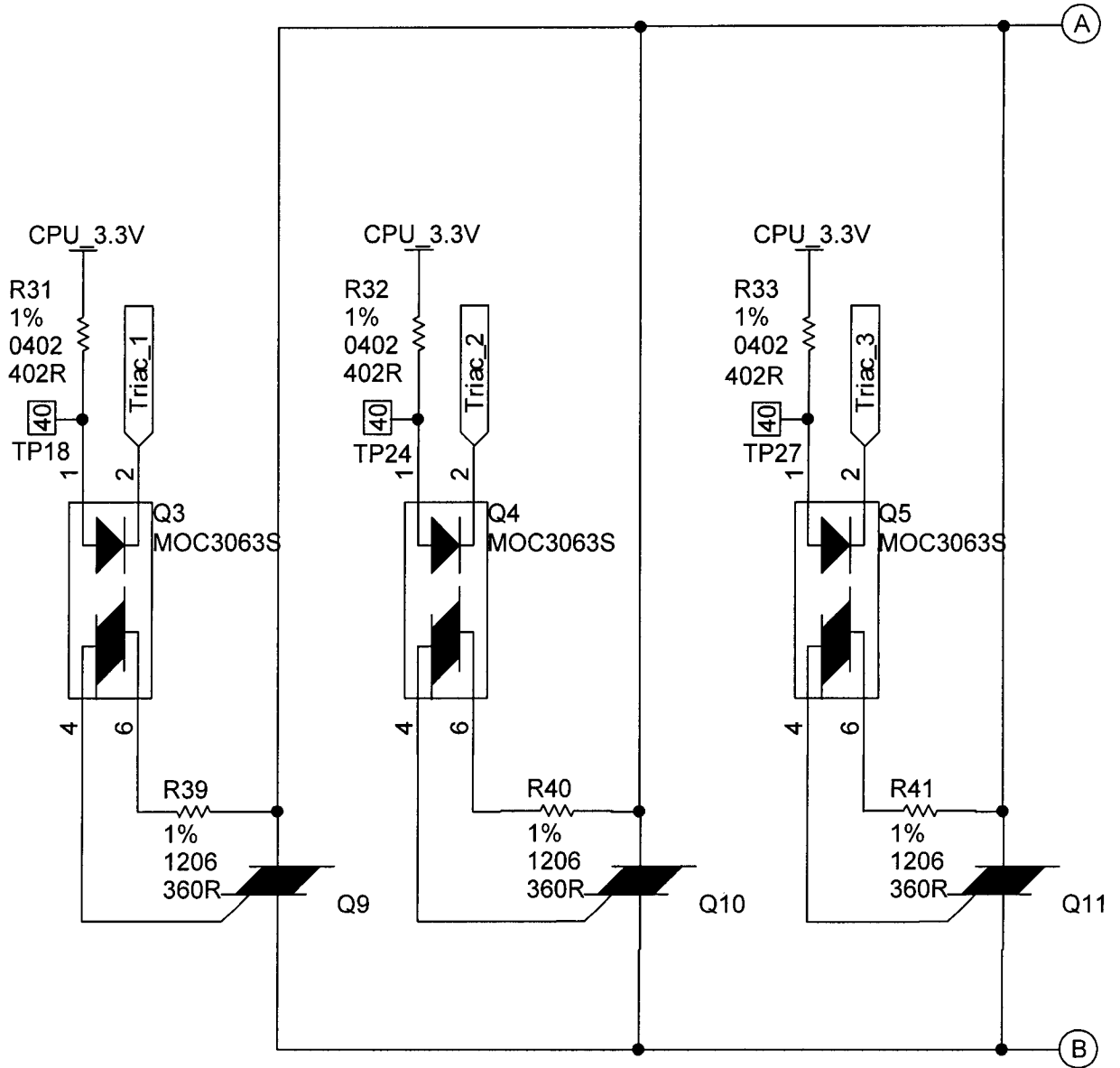
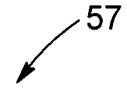

FIG. 21 continued



BOM_1
BOM_ITEMS →
HEATSINK

BOM_2
BOM_ITEMS →
HEATSINK

BOM_3
BOM_ITEMS →
HEATSINK

FIG. 22

57

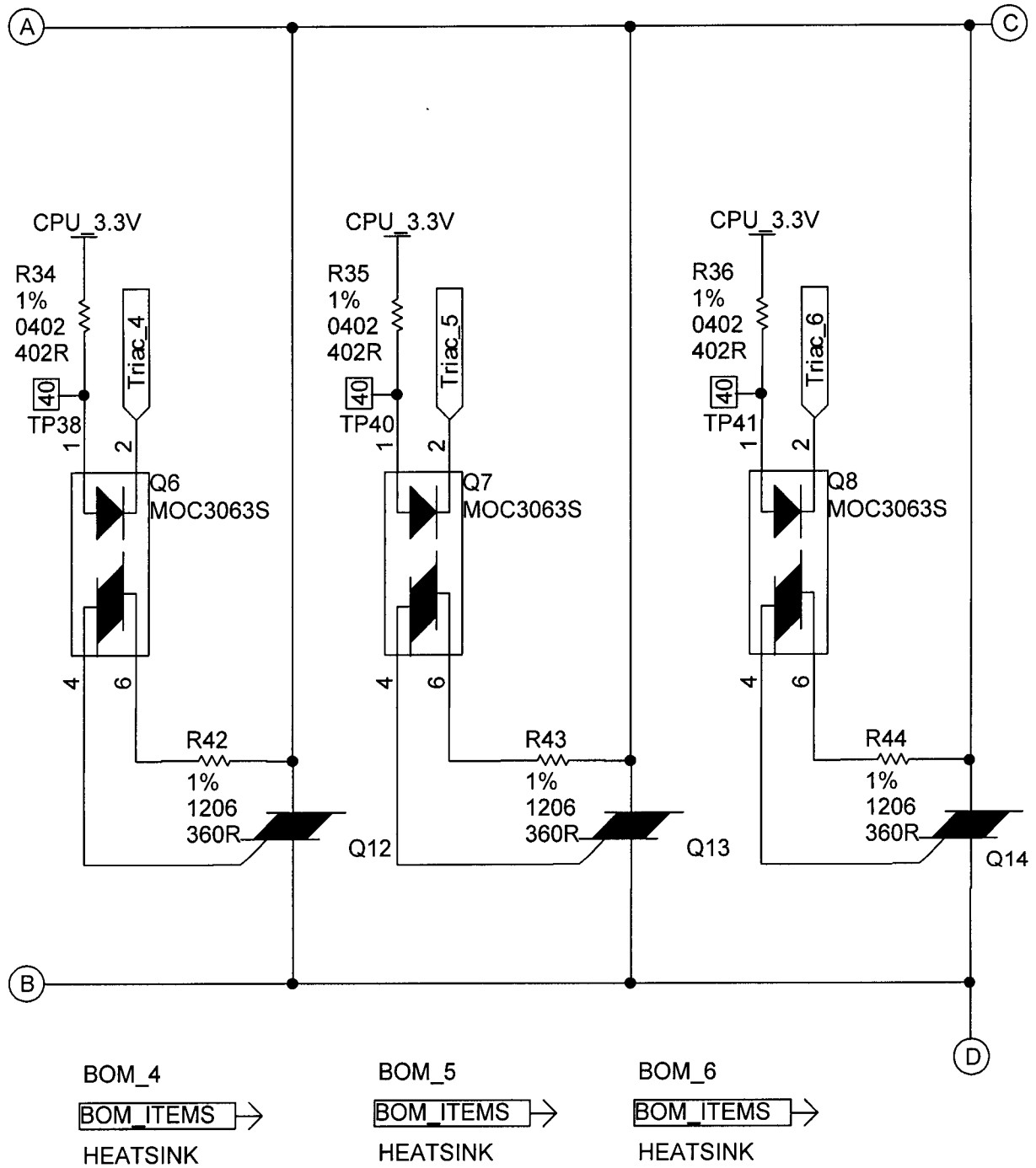

FIG. 22 continued

37/52

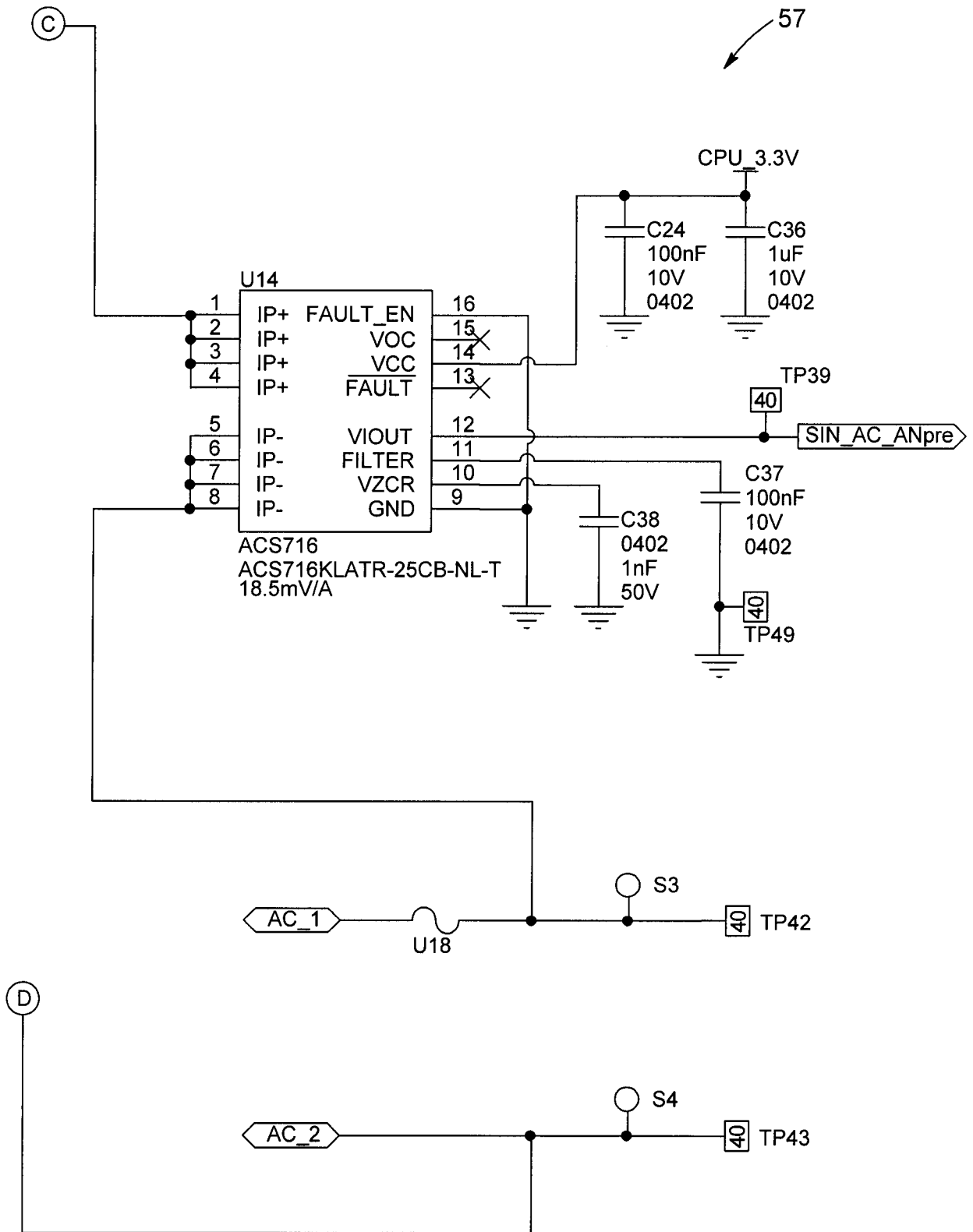

FIG. 22 continued

AC/DC 120VAC - 240VAC to 5V 1A

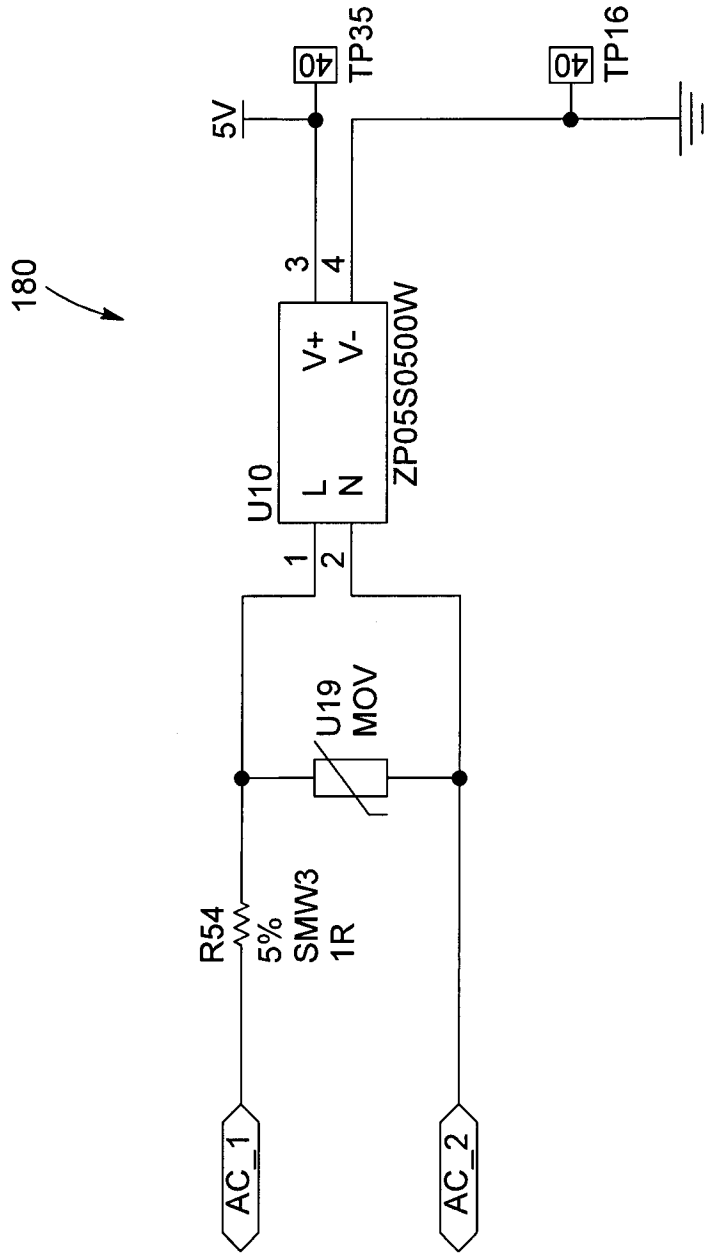

FIG. 23

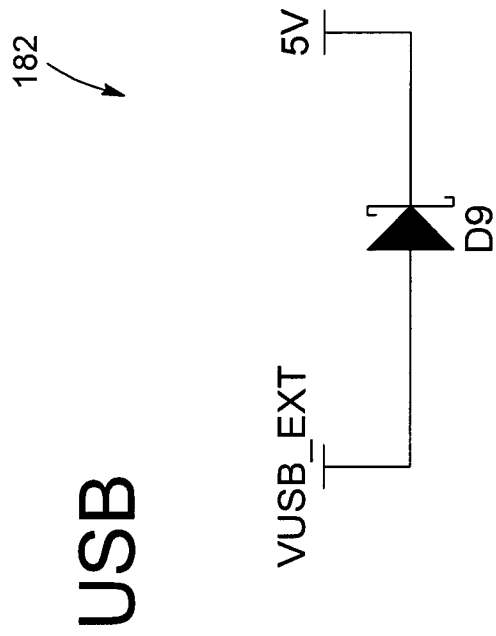

FIG. 24

Supply measure

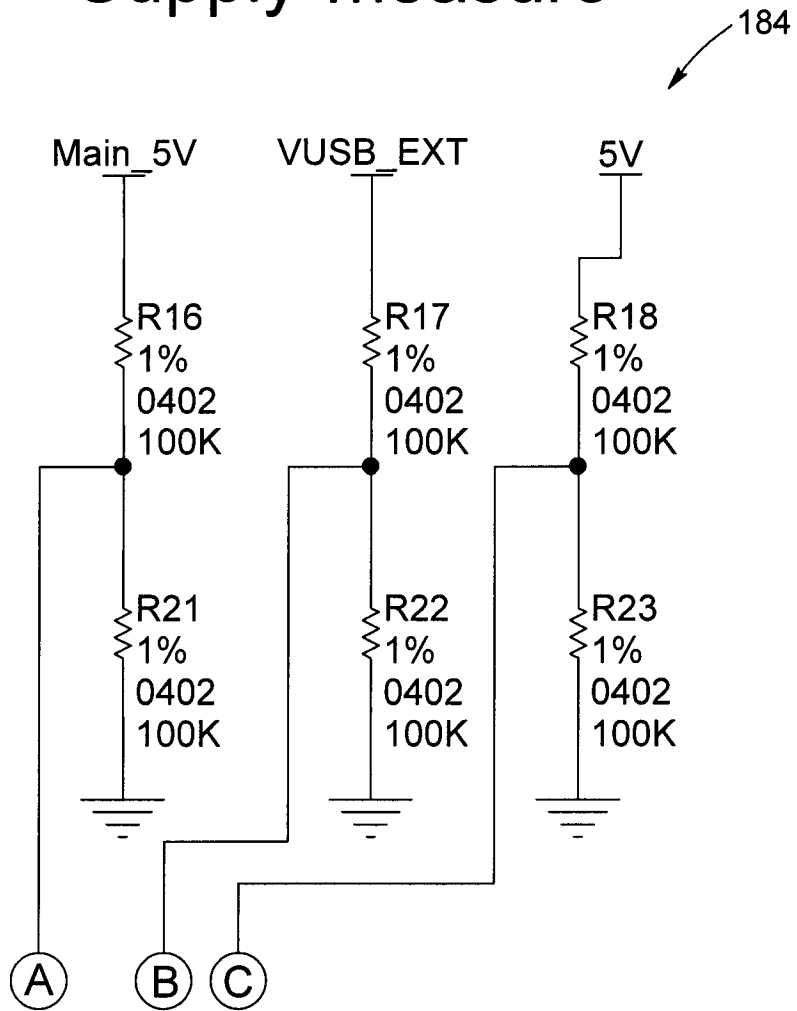

FIG. 25

Supply measure

184

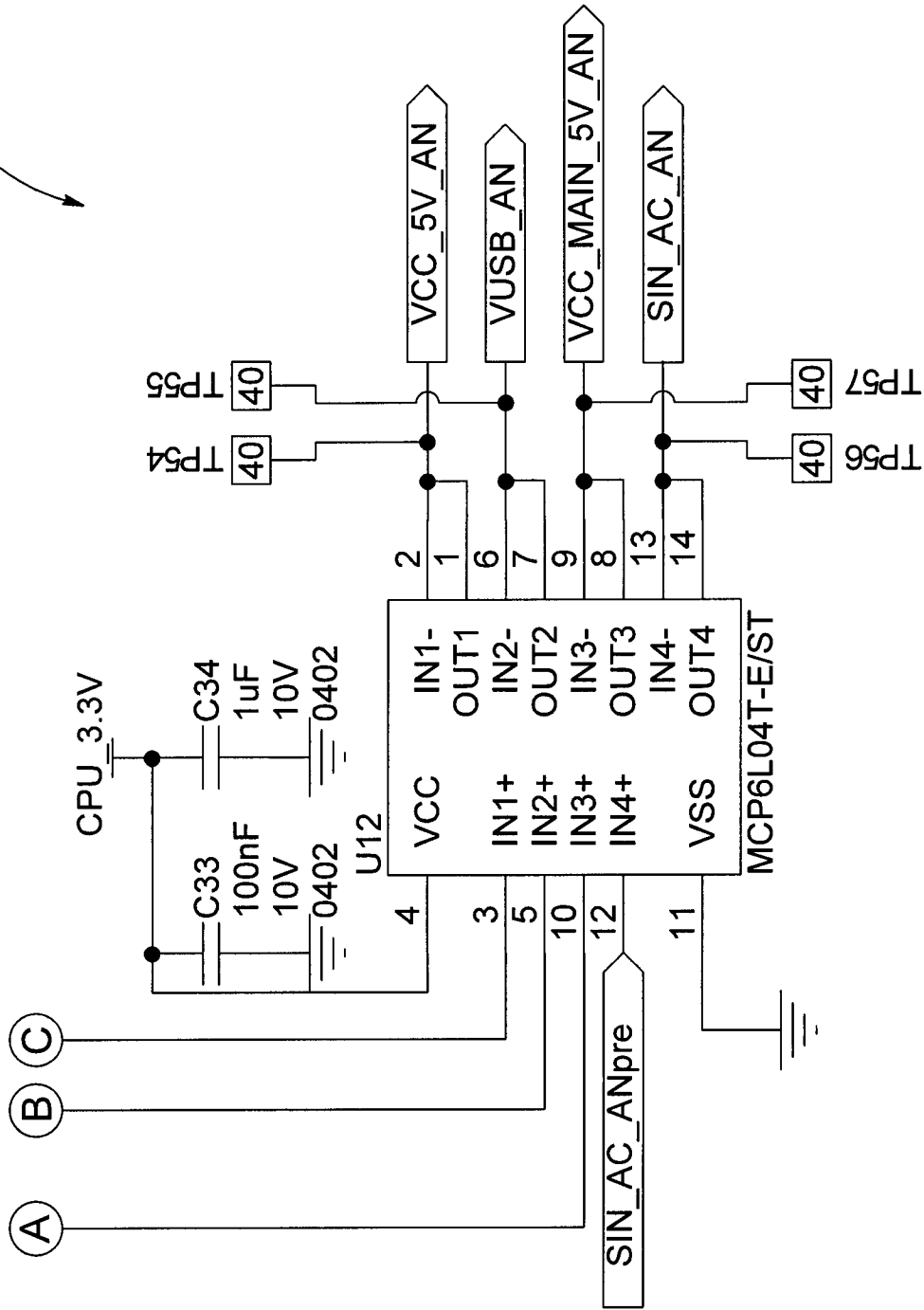
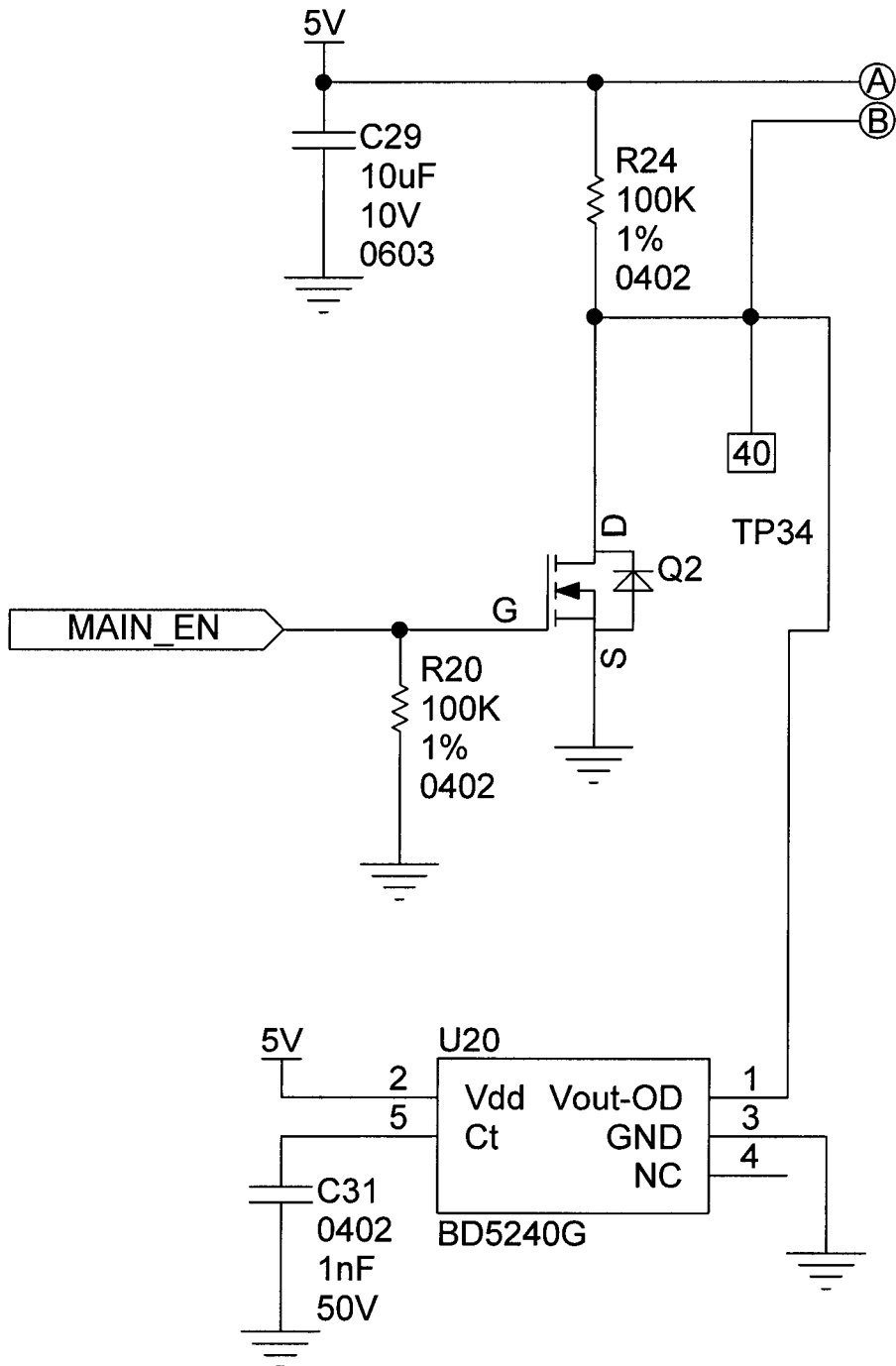

FIG. 25 continued

3.3V 18uA

42/52

186



Switch OFF Backfeed if < 4.0V

FIG. 26

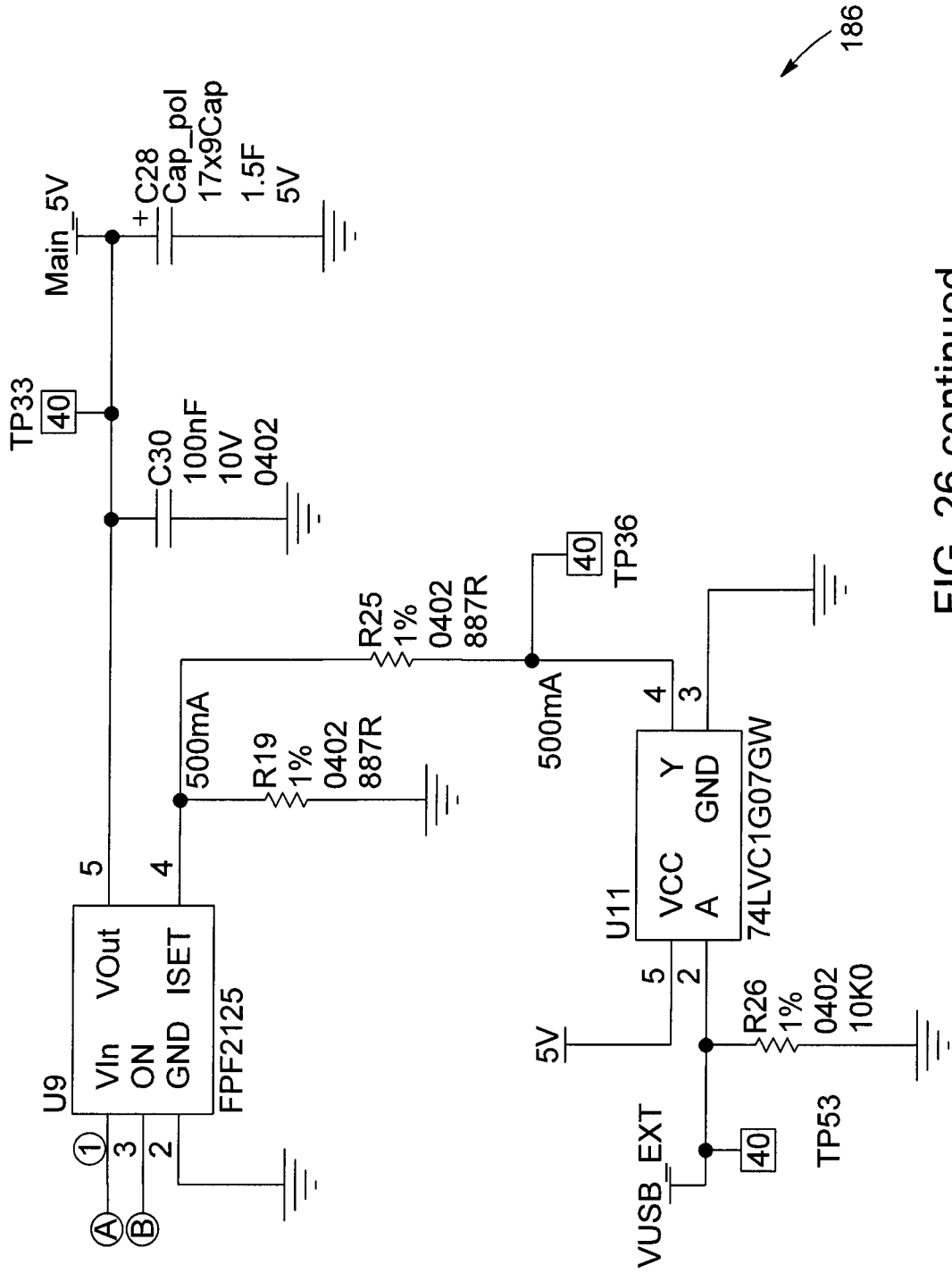

186

FIG. 26 continued

186

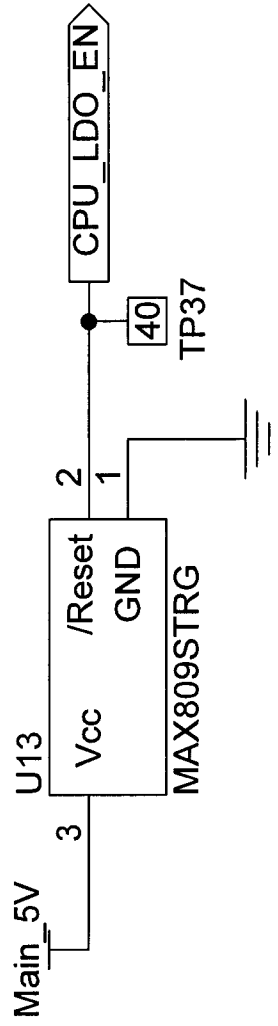

Switch OFF CPU if < 2.9V
Switch ON CPU if > 3V

FIG. 26 continued

45/52

- a: Data header - Language set via interface
- b: Actual temperature as read by onboard sensor
- c: Celsius or Fahrenheit - Locale set via interface
- d: Temperature set point - Via interface or local buttons
- e: Triac load status
- f: Clock - Locale set via interface
- g: Manual mode icon
- h: Connectivity icon
- i: Locked controls icon

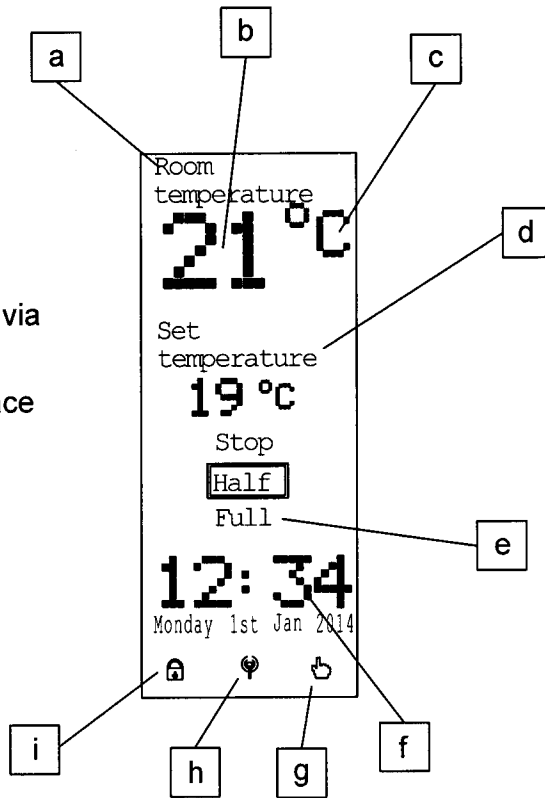

FIG. 27A

- j: UP button - Capacitive button
- k: DOWN button - Capacitive button
- l: RESET button (not shown) - Mechanical recessed button

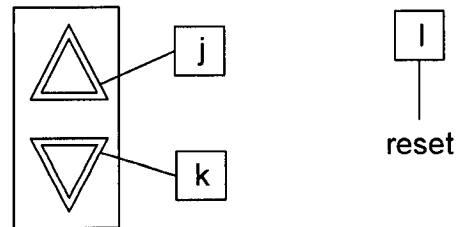

FIG. 27B

- m: Status LED - Visual feedback of load status
- n: Nightlight LED - Controlable via interface or local buttons

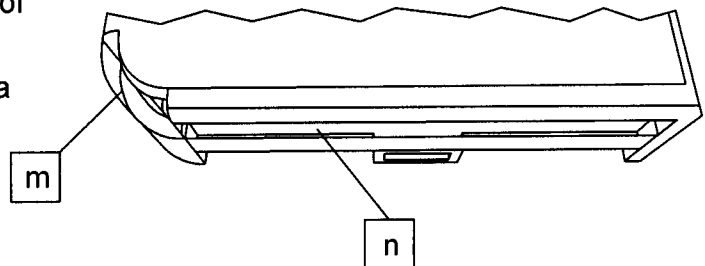

FIG. 27C

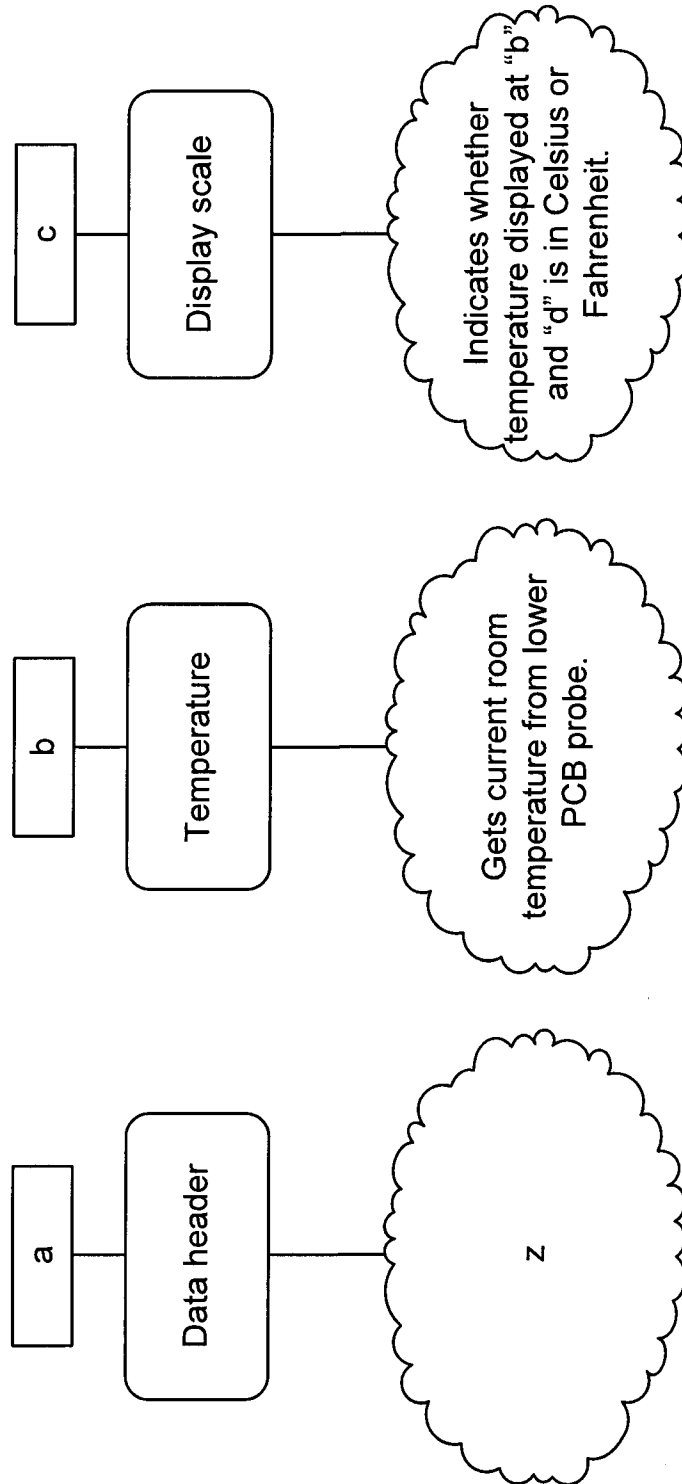

FIG. 28

47/52

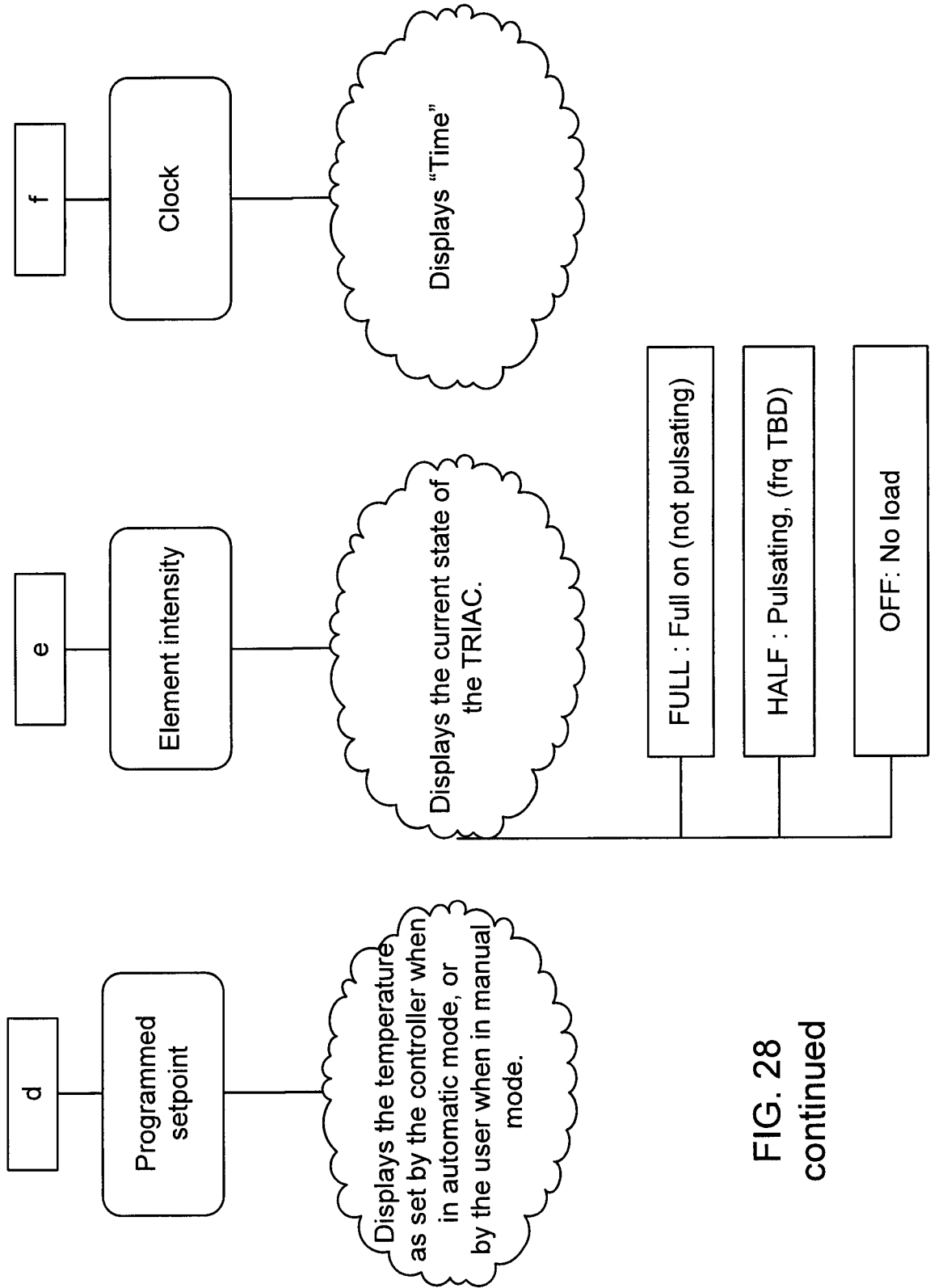

FIG. 28
continued

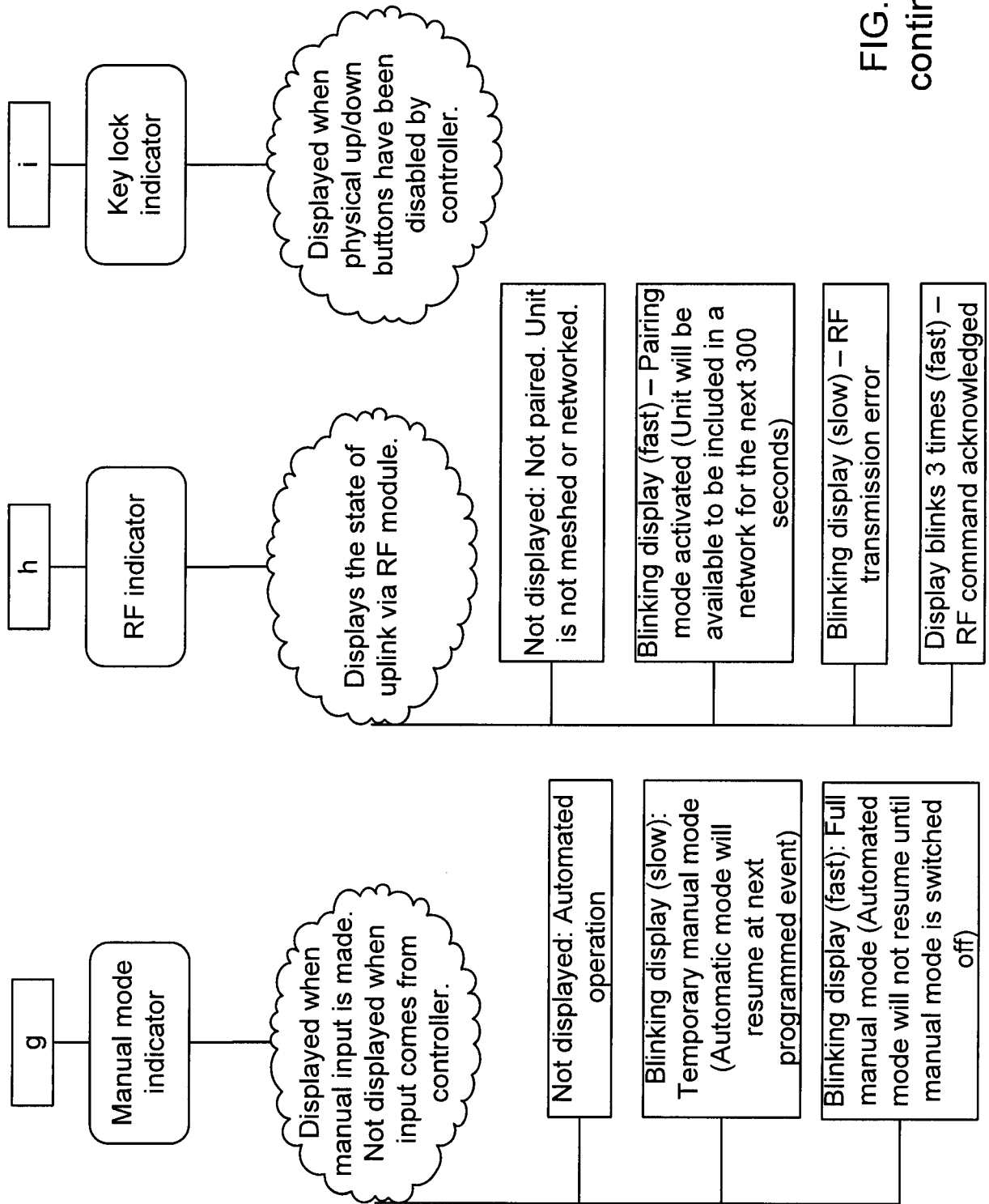

FIG. 28 continued

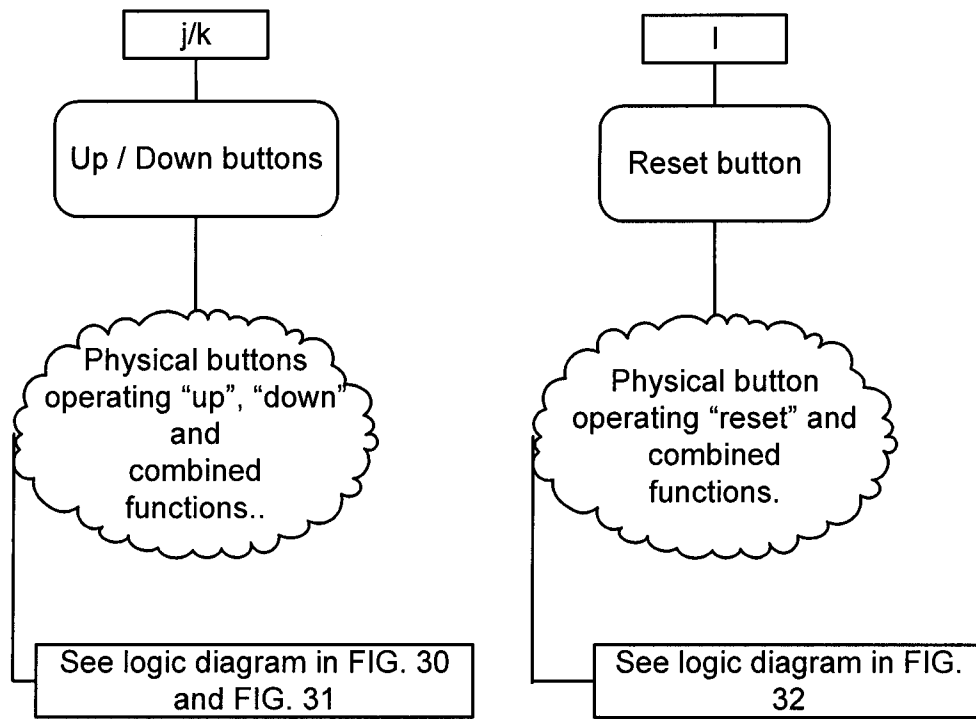

FIG. 29

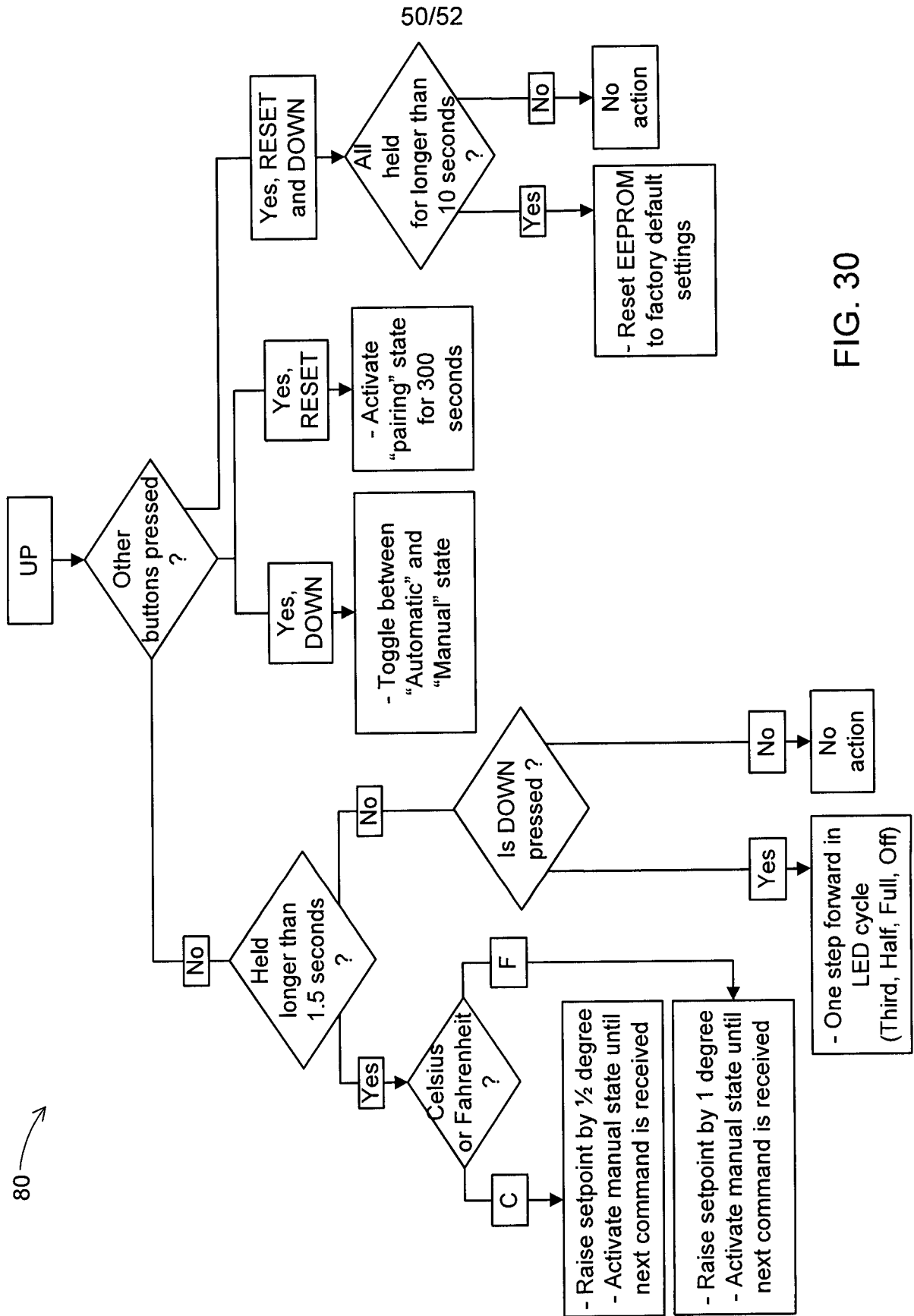

FIG. 30

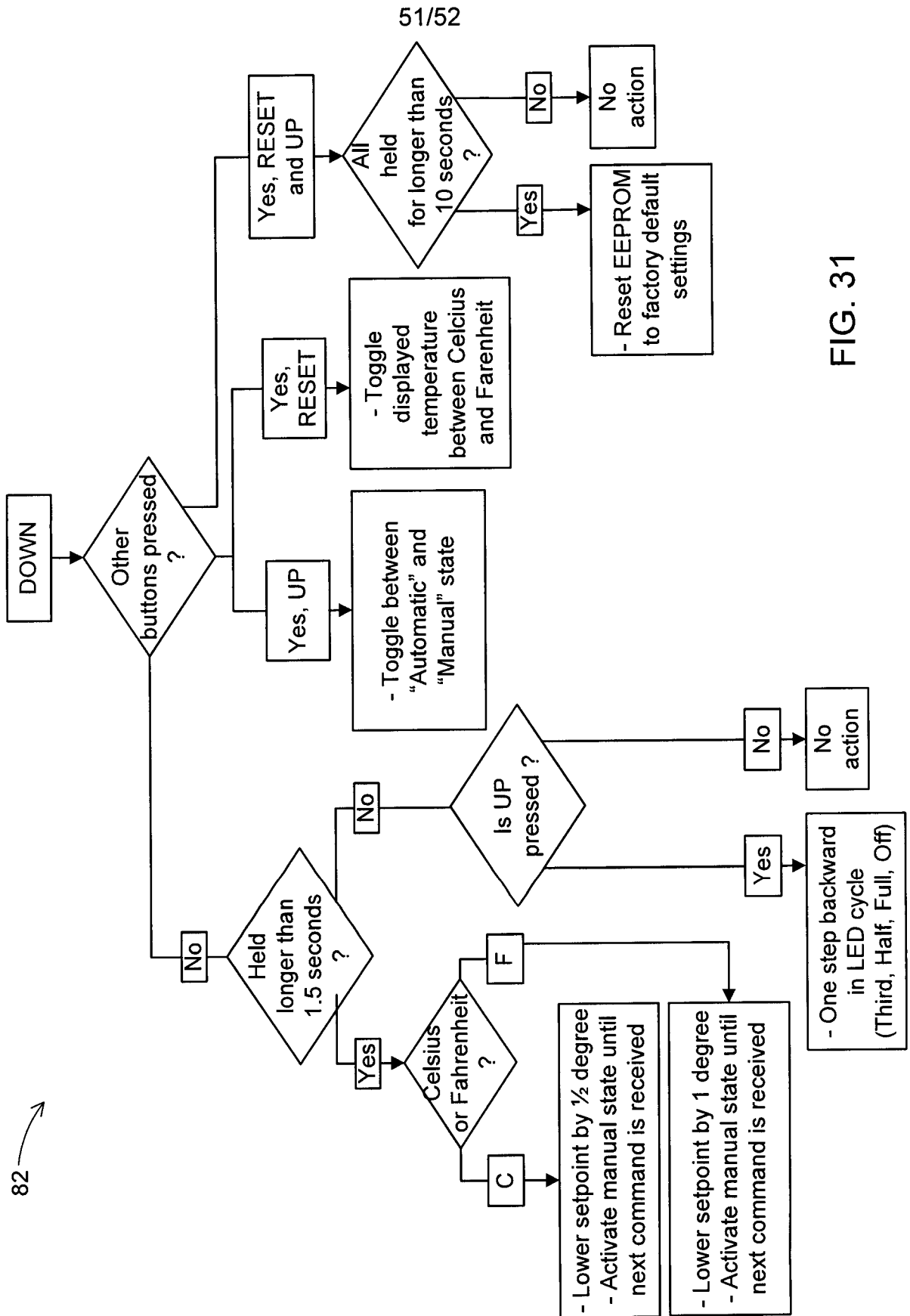

FIG. 31

82 ↗

84 ↗

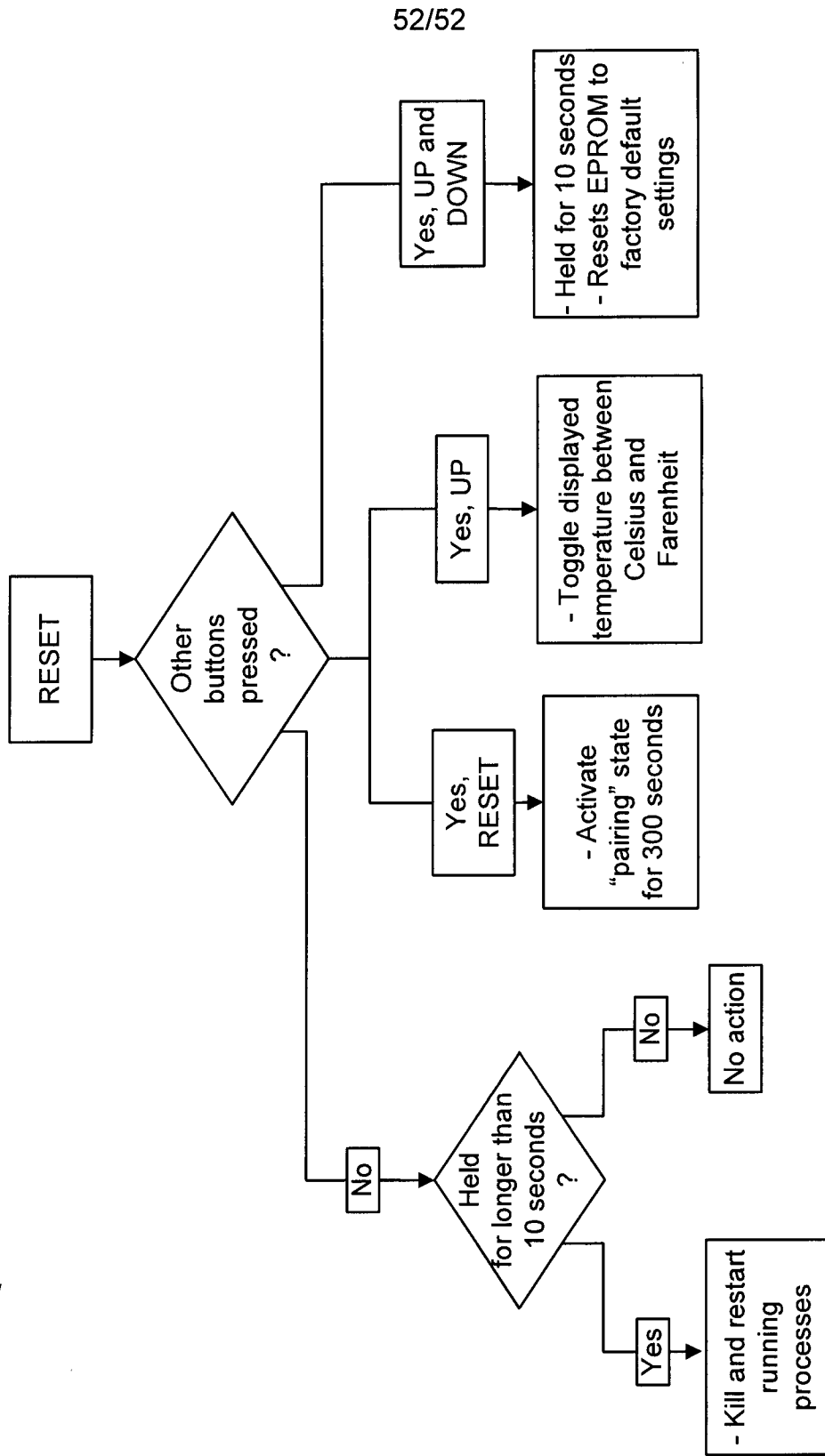

FIG. 32

INTERNATIONAL SEARCH REPORT

International application No.
PCT/CA2015/050156

A. CLASSIFICATION OF SUBJECT MATTER
 IPC: **G05D 23/19** (2006.01), **H02J 15/00** (2006.01), **H02J 7/00** (2006.01), **H05B 1/02** (2006.01)

According to International Patent Classification (IPC) or to both national classification and IPC

B. FIELDS SEARCHED

Minimum documentation searched (classification system followed by classification symbols)
 IPC: **G05D 23/19** (2006.01), **H02J 15/00** (2006.01), **H02J 7/00** (2006.01), **H05B 1/02** (2006.01)

Documentation searched other than minimum documentation to the extent that such documents are included in the fields searched

Electronic database(s) consulted during the international search (name of database(s) and, where practicable, search terms used)

Databases consulted: Questel, Google, IEEE, Canadian Patent Database

Keywords: thermostat, energy storage, battery, charging, temperature, power supply

C. DOCUMENTS CONSIDERED TO BE RELEVANT

Category*	Citation of document, with indication, where appropriate, of the relevant passages	Relevant to claim No.
X	US 4,433,719 28 Feb. 1984 (28-02-1984) Cherry et al. Abstract; col. 1, lines 19-26; Col. 2, lines 3-7 and 18-37;	1 to 63
PA	US 2014/0266669 A1 18 Sep. 2014 (18-09-2014) Fadell et al. *** See whole document ***	1 to 63

Further documents are listed in the continuation of Box C.

See patent family annex.

* Special categories of cited documents:	"T" later document published after the international filing date or priority date and not in conflict with the application but cited to understand the principle or theory underlying the invention
"A" document defining the general state of the art which is not considered to be of particular relevance	"X" document of particular relevance; the claimed invention cannot be considered novel or cannot be considered to involve an inventive step when the document is taken alone
"E" earlier application or patent but published on or after the international filing date	"Y" document of particular relevance; the claimed invention cannot be considered to involve an inventive step when the document is combined with one or more other such documents, such combination being obvious to a person skilled in the art
"L" document which may throw doubts on priority claim(s) or which is cited to establish the publication date of another citation or other special reason (as specified)	"&" document member of the same patent family
"O" document referring to an oral disclosure, use, exhibition or other means	
"P" document published prior to the international filing date but later than the priority date claimed	

Date of the actual completion of the international search
28 April 2015 (28-04-2015)

Date of mailing of the international search report
14 May 2015 (14-05-2015)

Name and mailing address of the ISA/CA
 Canadian Intellectual Property Office
 Place du Portage I, C114 - 1st Floor, Box PCT
 50 Victoria Street
 Gatineau, Quebec K1A 0C9
 Facsimile No.: 001-819-953-2476

Authorized officer
 Francois Ziade (819) 994-7460

INTERNATIONAL SEARCH REPORT
Information on patent family members

International application No.
PCT/CA2015/050156

Patent Document Cited in Search Report	Publication Date	Patent Family Member(s)	Publication Date
US4433719A	28 February 1984 (28-02-1984)	None	
US201426669A1	18 September 2014 (18-09-2014)	CA2885731A1 US2014085092A1 US8994540B2 US2014085093A1 US9007222B2 US2014084165A1 US2015021993A1 US2015021997A1 US2015022026A1 US2015022339A1 US2015022341A1 US2015022345A1 US2015022346A1 US2015022349A1 US2015022367A1 US2015022368A1 US2015061859A1 US2015070181A1 US2015096170A1 US2015096876A1 US2015109104A1 US2015109112A1 US2015109128A1 US2015112885A1 WO2014047501A1 WO2014143936A1 WO2014150284A1 WO2014150667A1 WO2014159131A2 WO2014159131A3 WO2015009908A1 WO2015009924A1	27 March 2014 (27-03-2014) 27 March 2014 (27-03-2014) 31 March 2015 (31-03-2015) 27 March 2014 (27-03-2014) 14 April 2015 (14-04-2015) 27 March 2014 (27-03-2014) 22 January 2015 (22-01-2015) 22 January 2015 (22-01-2015) 22 January 2015 (22-01-2015) 22 January 2015 (22-01-2015) 22 January 2015 (22-01-2015) 22 January 2015 (22-01-2015) 22 January 2015 (22-01-2015) 22 January 2015 (22-01-2015) 22 January 2015 (22-01-2015) 22 January 2015 (22-01-2015) 22 January 2015 (22-01-2015) 22 January 2015 (22-01-2015) 05 March 2015 (05-03-2015) 12 March 2015 (12-03-2015) 09 April 2015 (09-04-2015) 09 April 2015 (09-04-2015) 23 April 2015 (23-04-2015) 23 April 2015 (23-04-2015) 23 April 2015 (23-04-2015) 23 April 2015 (23-04-2015) 27 March 2014 (27-03-2014) 18 September 2014 (18-09-2014) 25 September 2014 (25-09-2014) 25 September 2014 (25-09-2014) 02 October 2014 (02-10-2014) 20 November 2014 (20-11-2014) 22 January 2015 (22-01-2015) 22 January 2015 (22-01-2015)