

(21) Application No: 1116054.6
(22) Date of Filing: 16.09.2011
(30) Priority Data:
(31) 12888005 (32) 22.09.2010 (33) US

(51) INT CL:
A61B 17/17 (2006.01) A61B 17/15 (2006.01)

(56) Documents Cited:
WO 2007/145937 A US 5041117 A
US 4927422 A US 20080161815 A
US 20080114370 A US 20050043806 A
US 20030009171 A1

(71) Applicant(s):
Biomet Manufacturing Corp.
56 E. Bell Drive, Warsaw 46582, Indiana,
United States of America

(58) Field of Search:
INT CL A61B
Other: EPODOC, WPI

(72) Inventor(s):
Nicholas J Katrana
Thomas M Vanasse
Robert Metzger

(74) Agent and/or Address for Service:
Haseltine Lake LLP
5th Floor Lincoln House, 300 High Holborn, LONDON,
WC1V 7JH, United Kingdom

(54) Title of the Invention: **Patient-specific elbow guides and associated methods**
Abstract Title: **Alignment guide for elbow joint**

(57) A patient-specific alignment guide 200 includes a three-dimensional engagement surface 202 customized in a pre-operating planning stage by computer imaging to closely mate and conform to a corresponding bone portion 72 of a patient's elbow joint. The patient-specific alignment guide 200 defines a first longitudinal guiding bore 206 aligned with a reference axis (A) associated with the elbow joint of patient when the alignment guide 200 is mounted onto the corresponding bone portion 72. In another aspect a cutting component (502, Fig 7A) is described with elongate slots 504 and a guiding component 530.

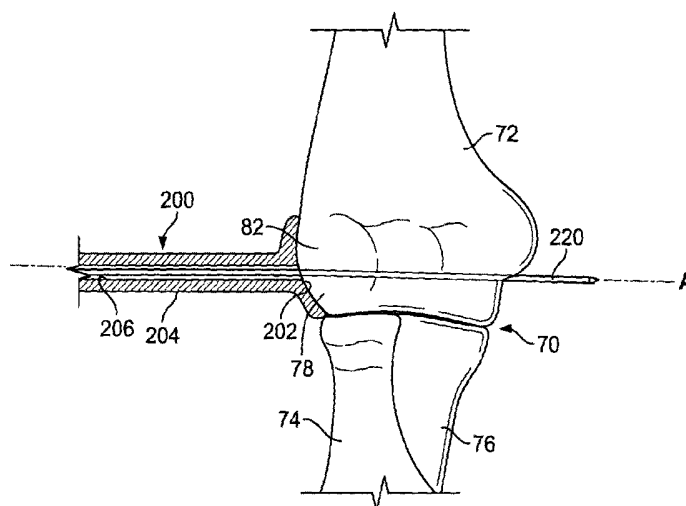

FIG. 3

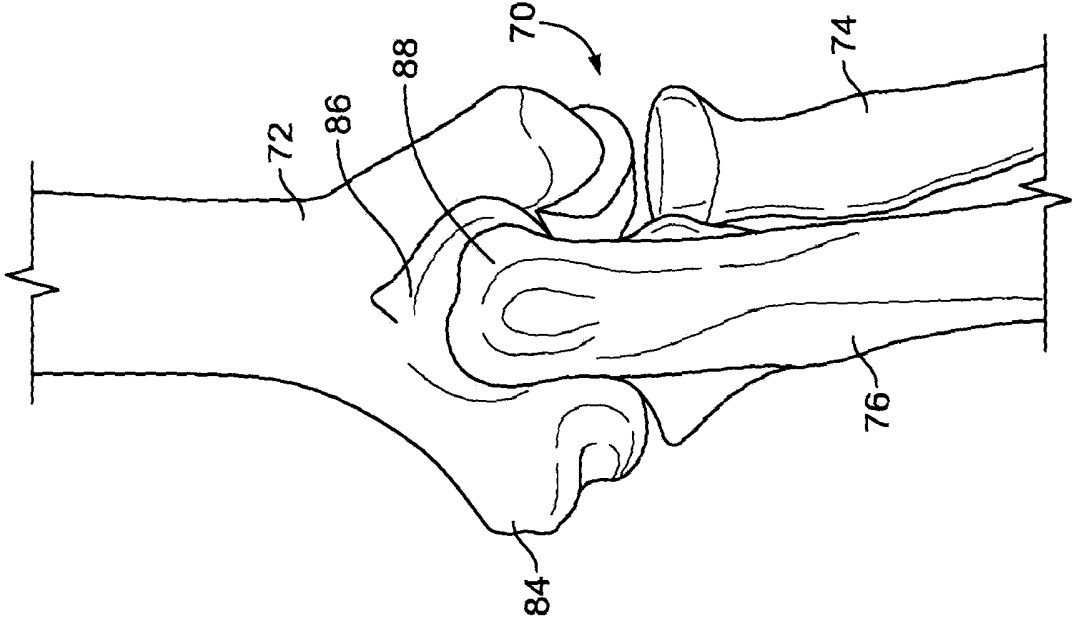

FIG. 1A

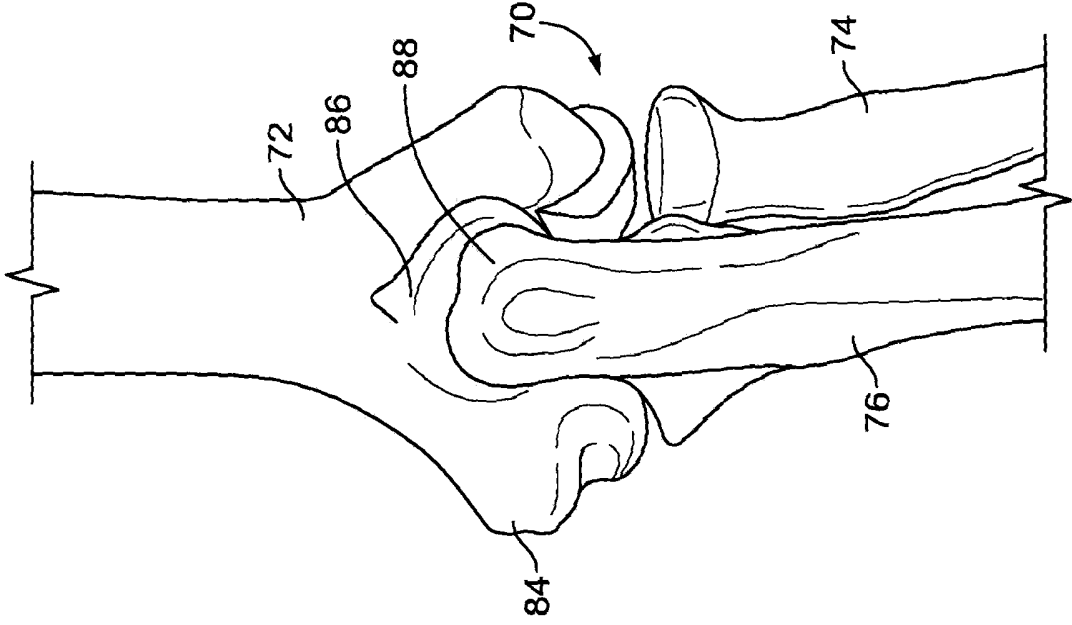

FIG. 1B

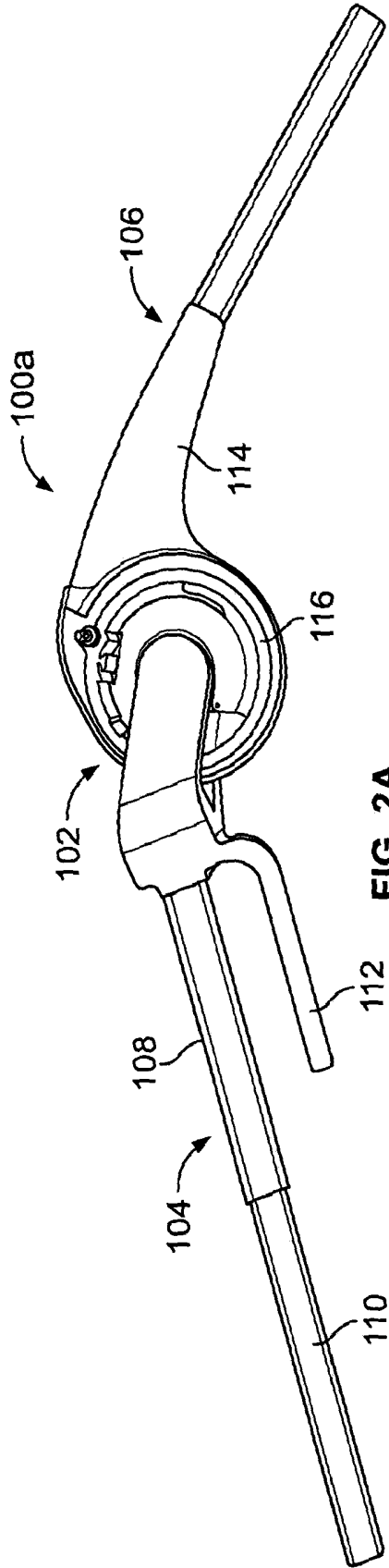

FIG. 2A

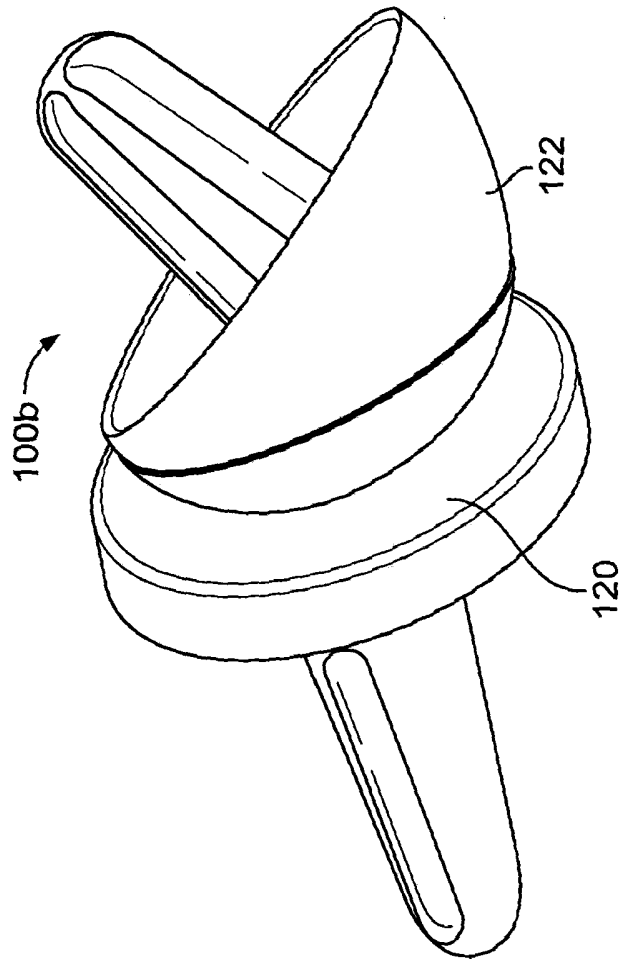

FIG. 2B

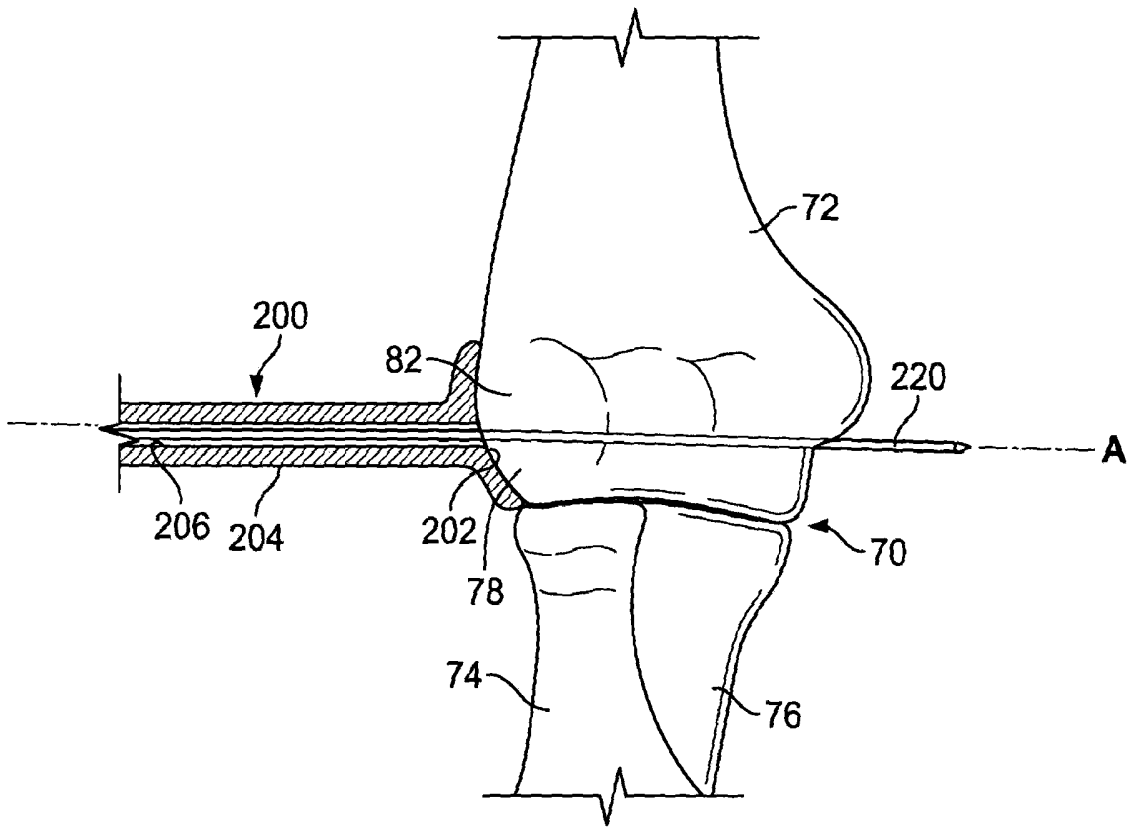

FIG. 3

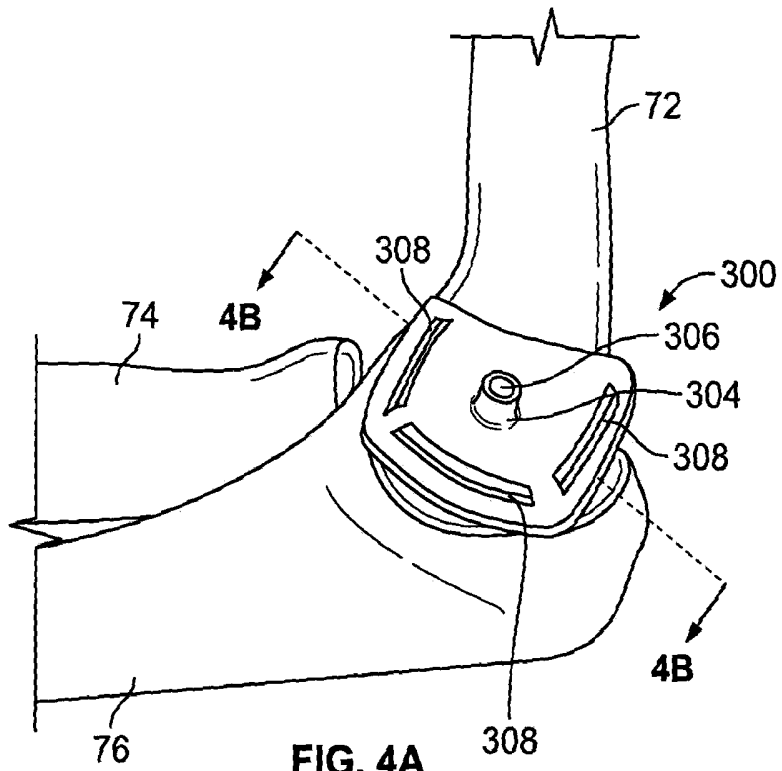

FIG. 4A

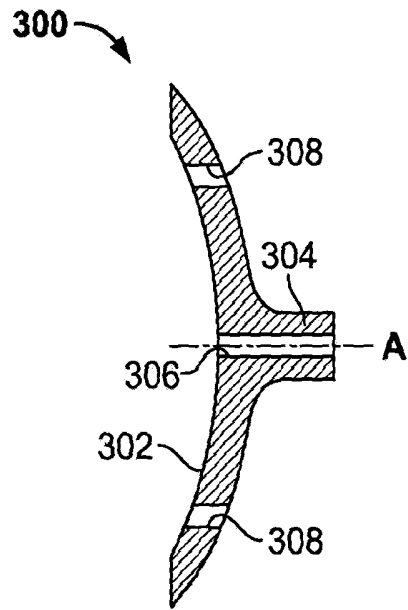

FIG. 4B

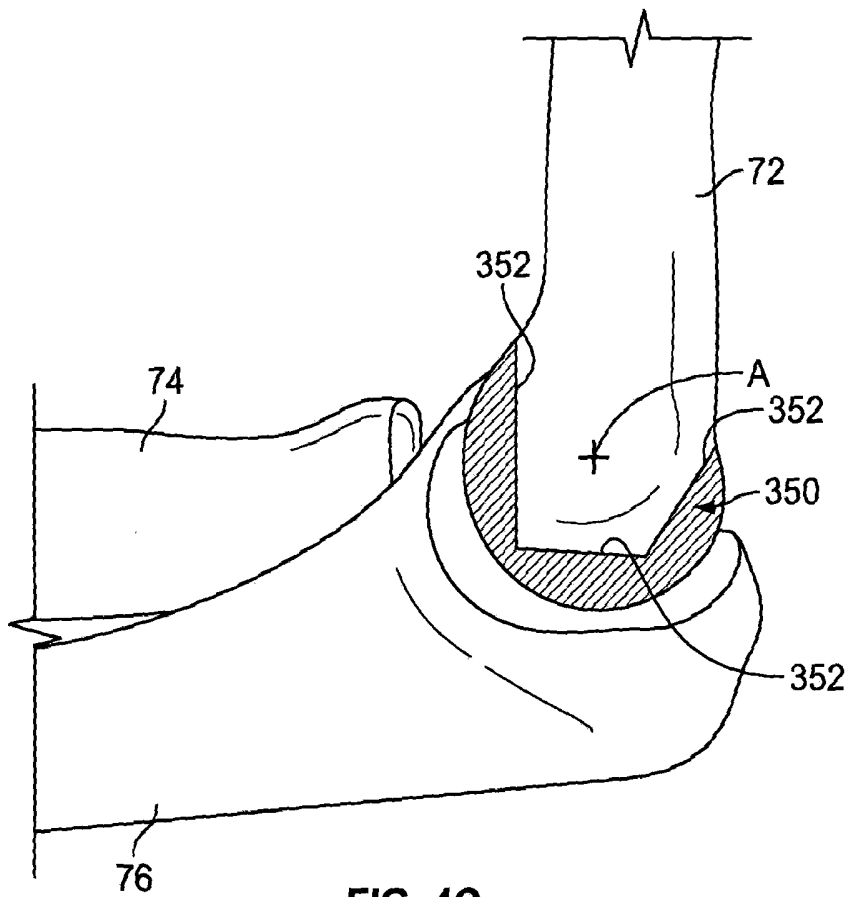

FIG. 4C

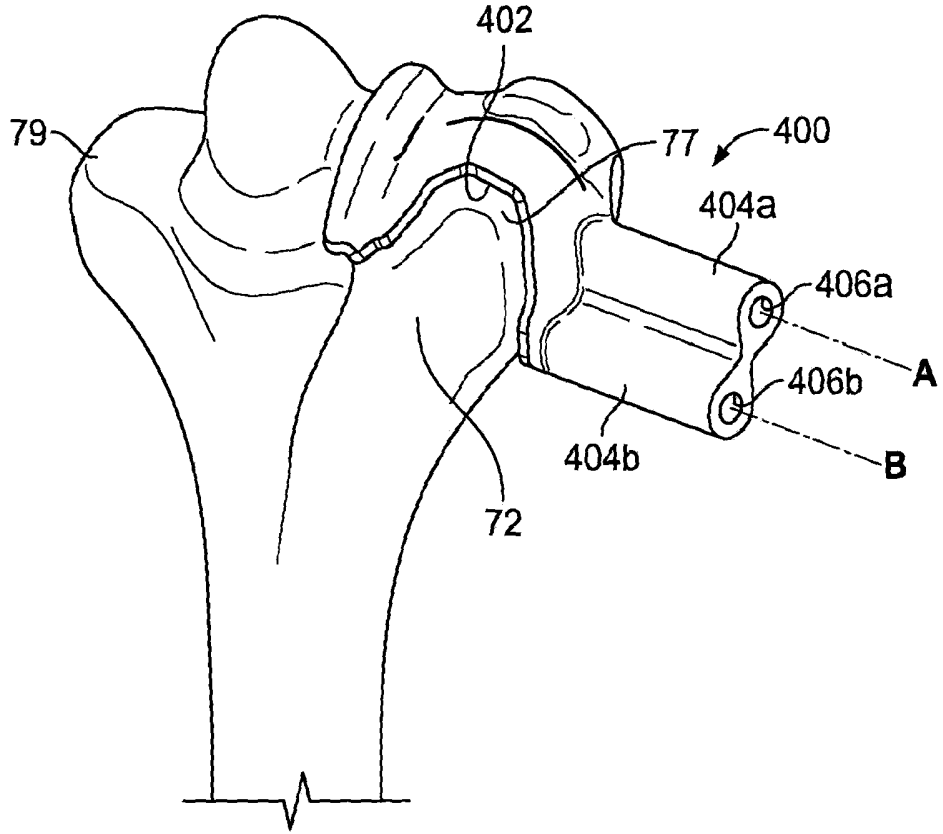

FIG. 5

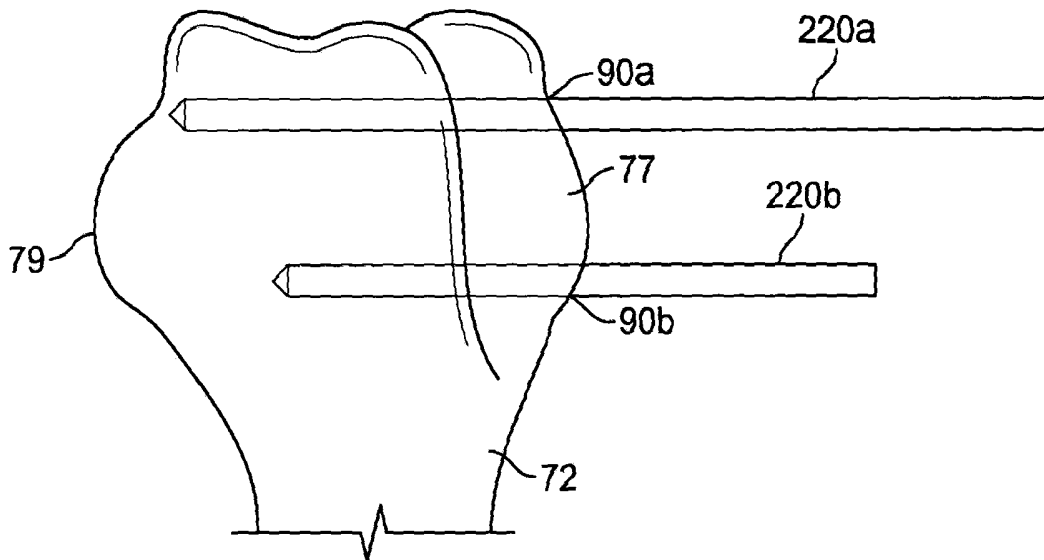

FIG. 6

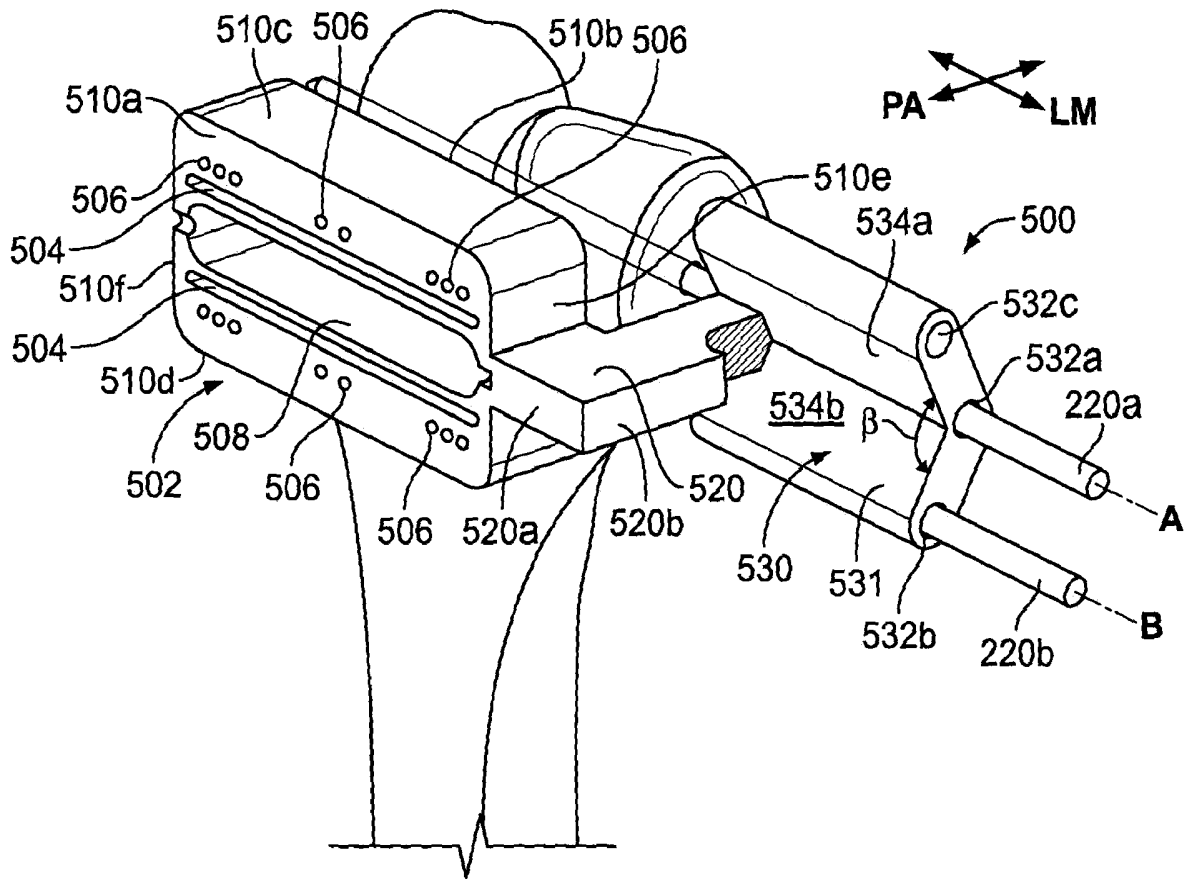

FIG. 7A

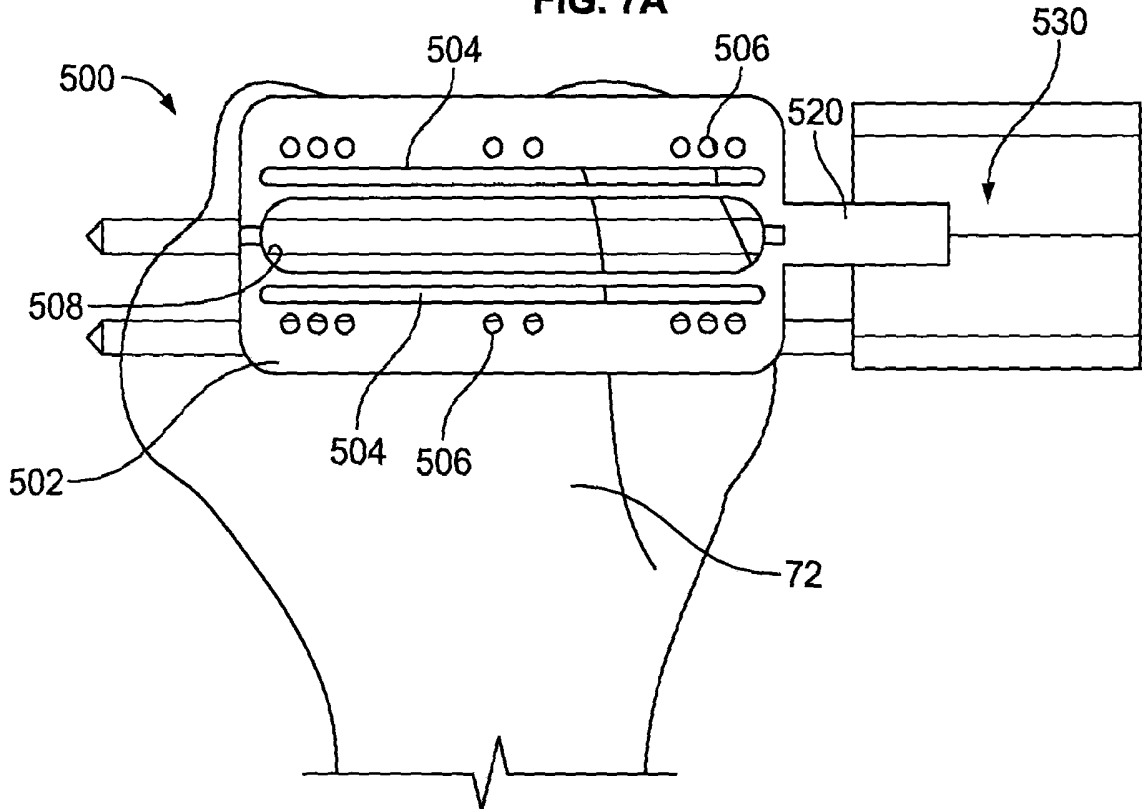

FIG. 7B

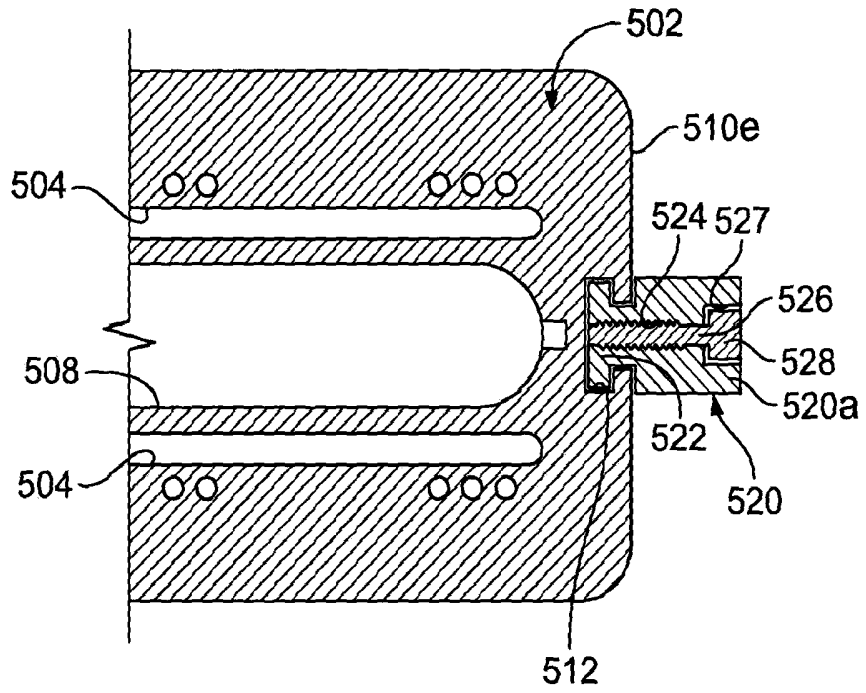

FIG. 7C

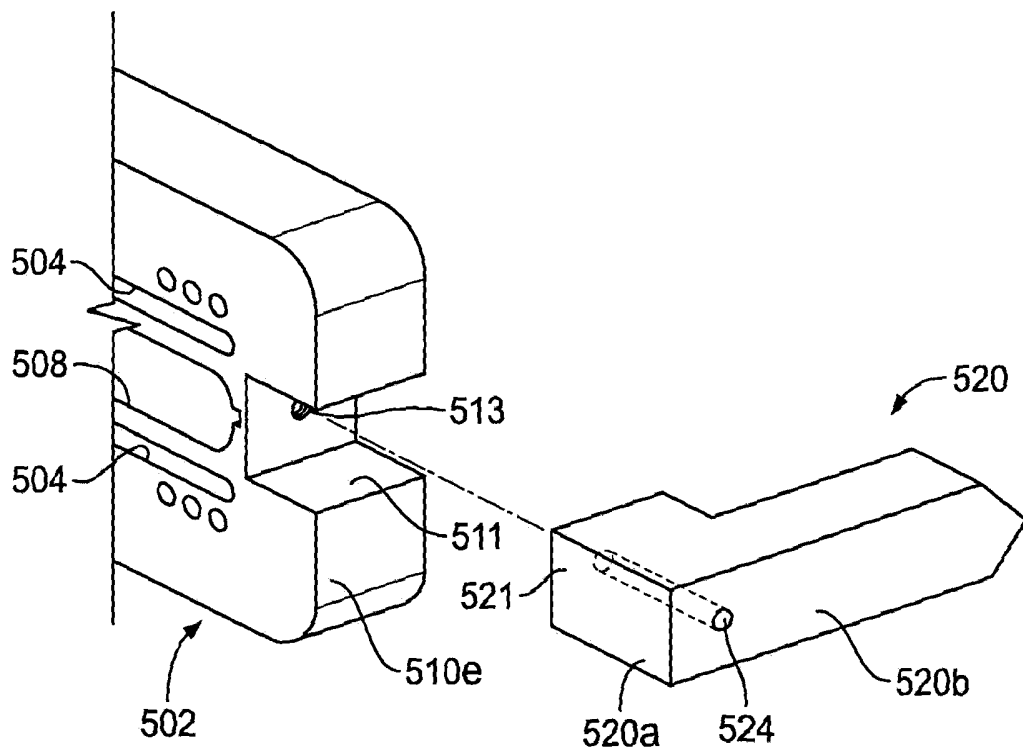

FIG. 7D

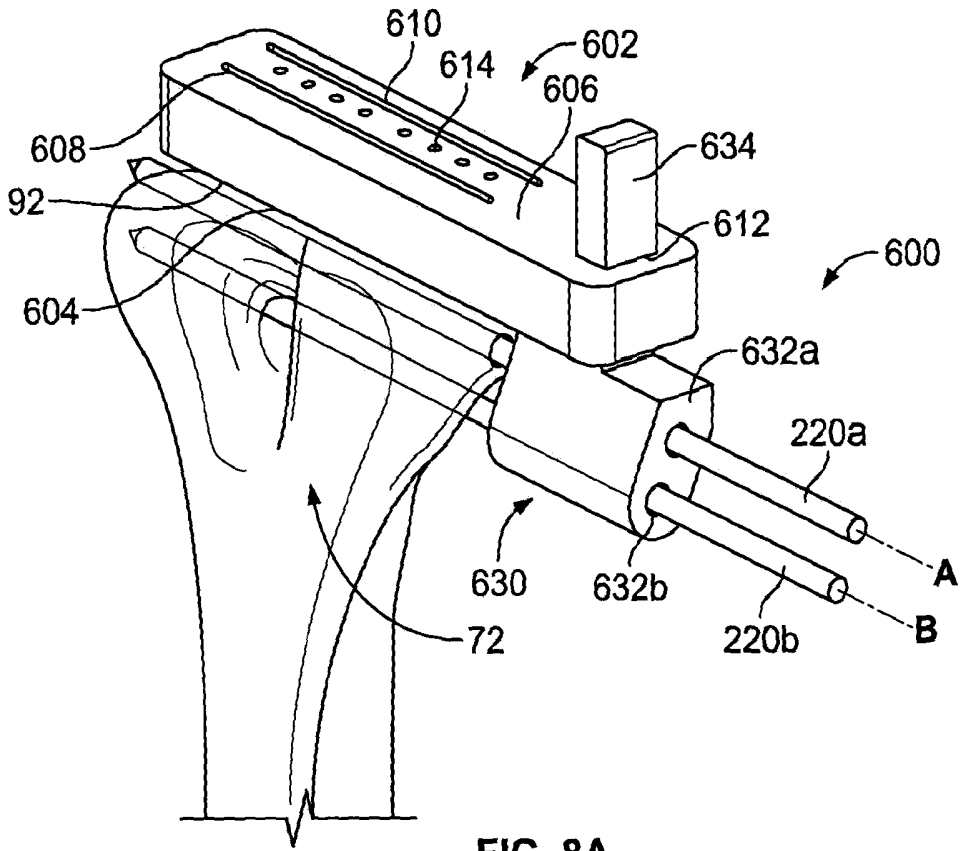

FIG. 8A

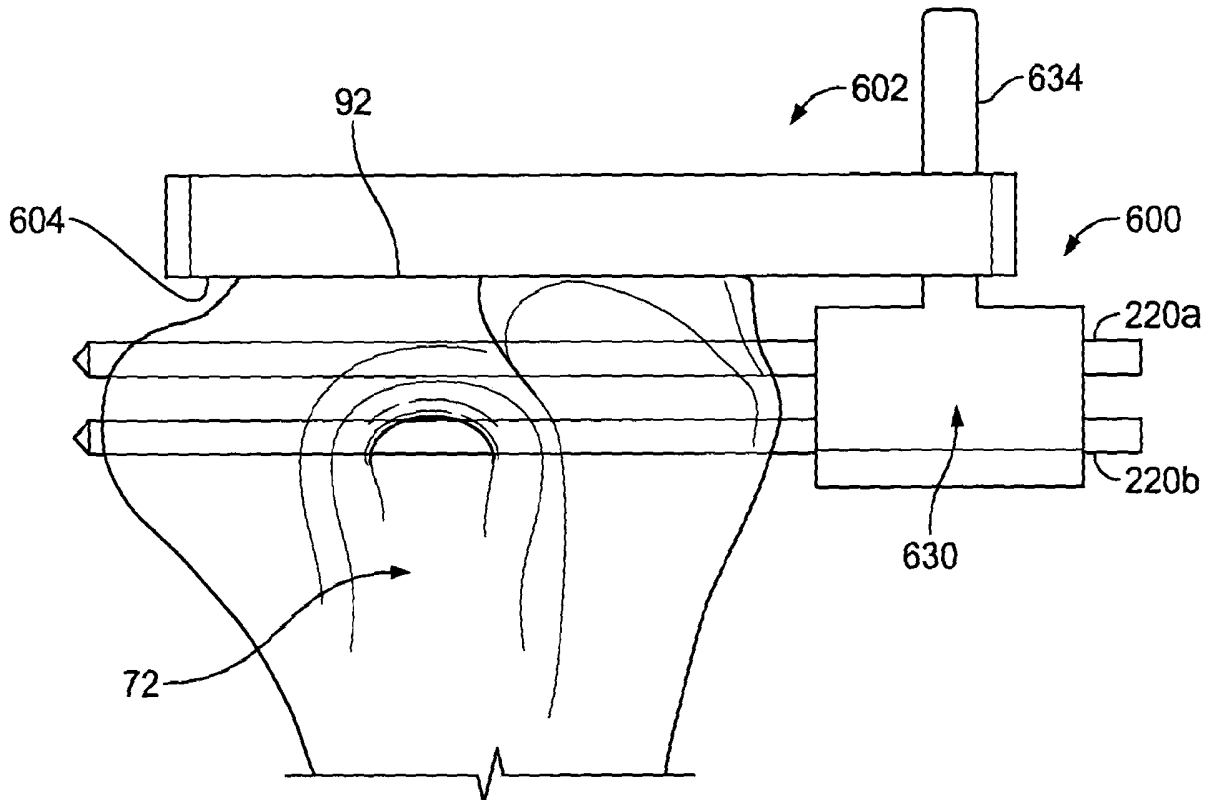

FIG. 8B

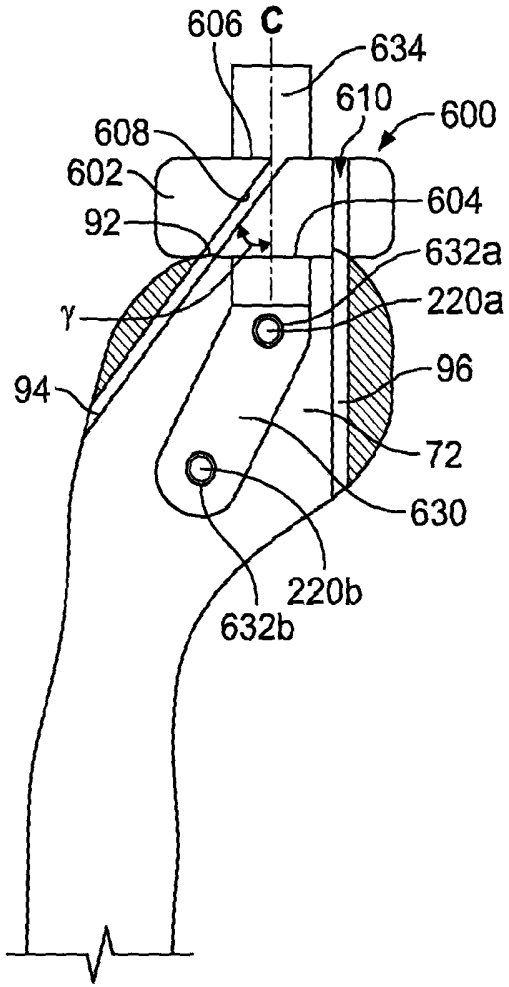

FIG. 8C

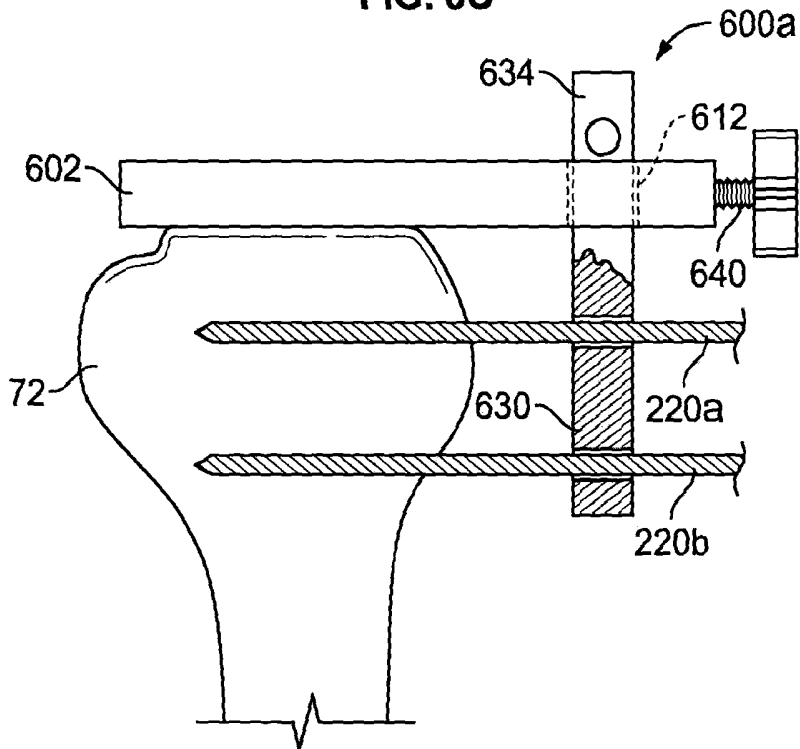

FIG. 9

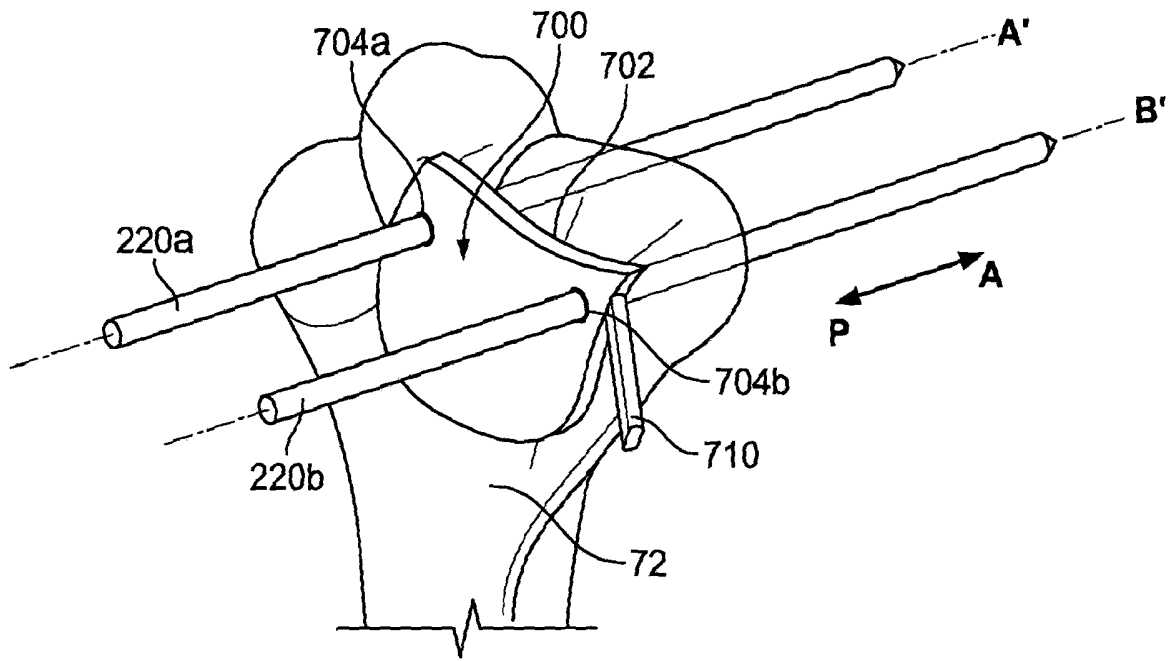

FIG. 10

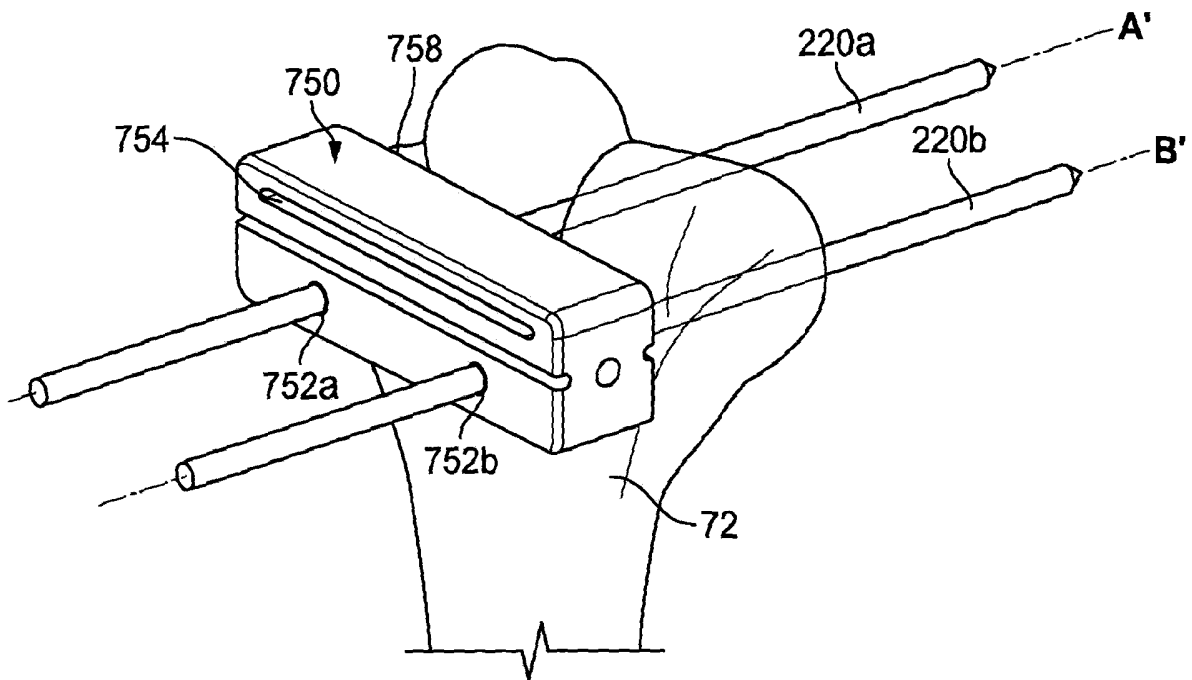

FIG. 11

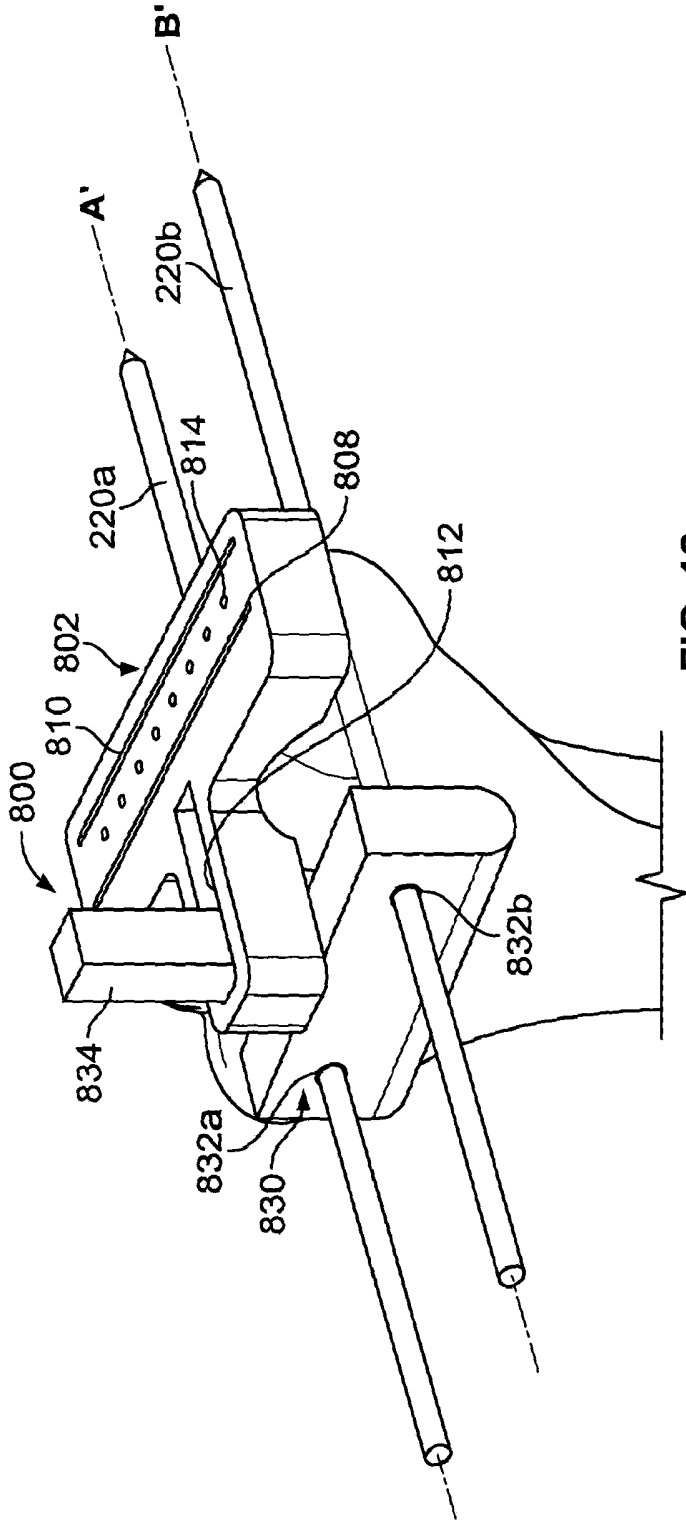

FIG. 12

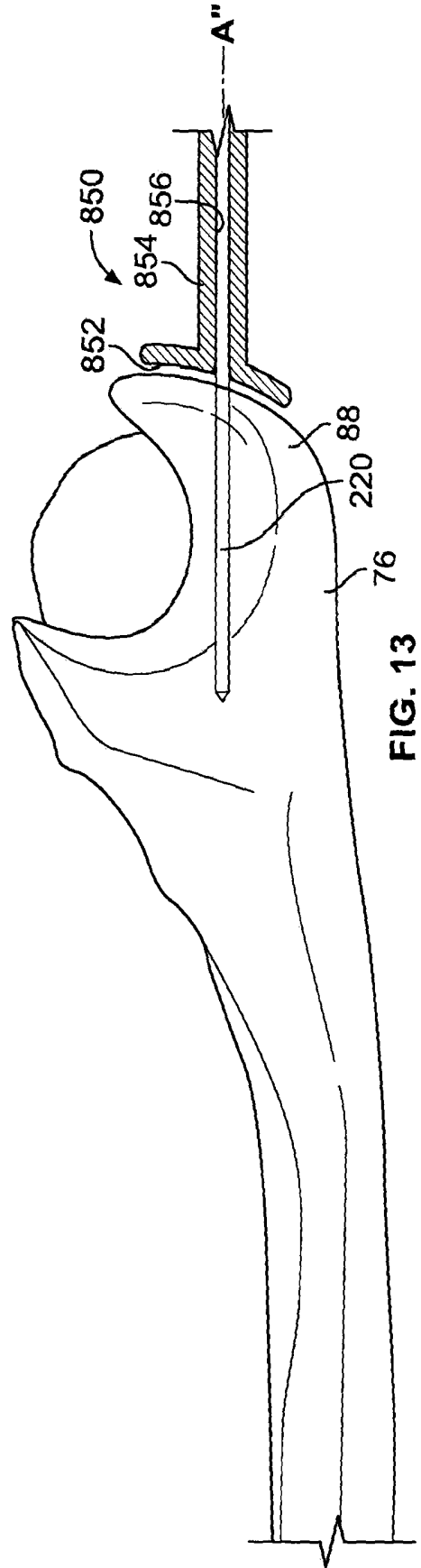

FIG. 13

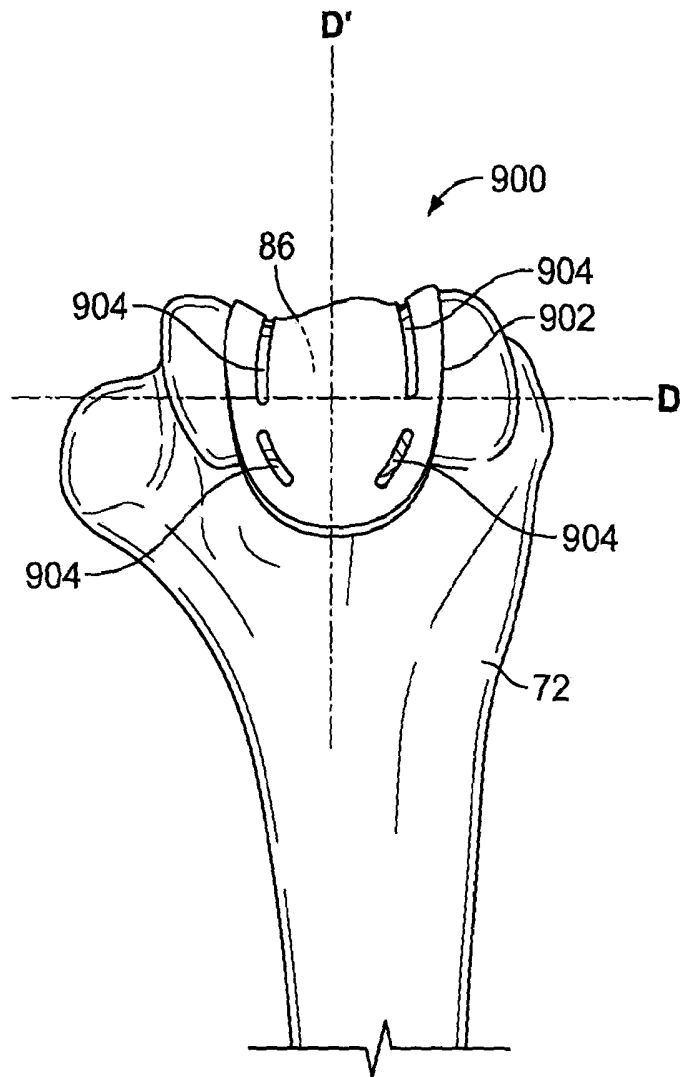
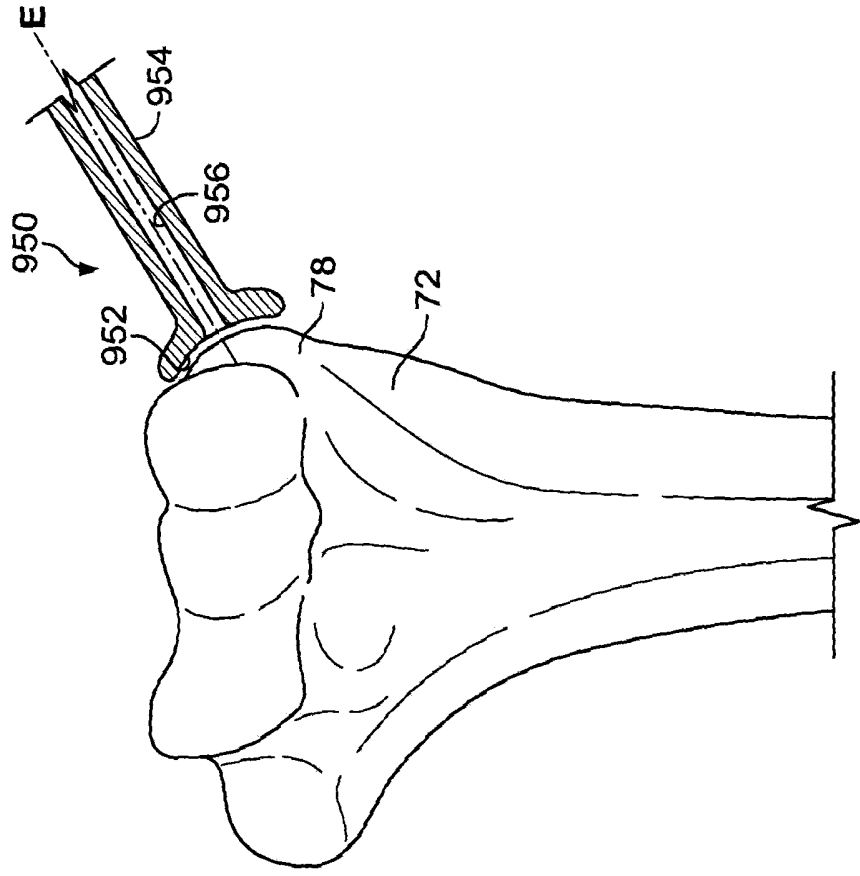
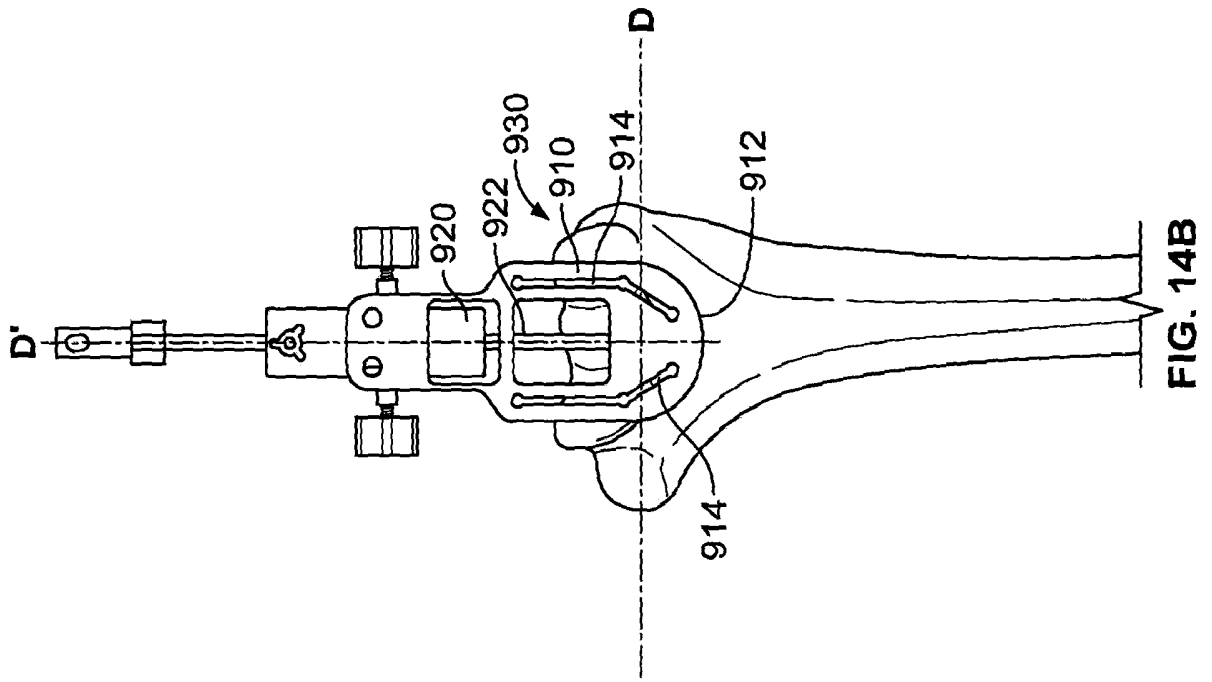

FIG. 14A



PATIENT-SPECIFIC ELBOW GUIDES AND ASSOCIATED METHODS

CROSS-REFERENCE TO RELATED APPLICATIONS

[0001] This application is a continuation-in-part of US Application No. 12/714,023, filed February 26, 2010, which is a continuation-in-part of US Application No. 12/571,969, filed October 1, 2009, which is a continuation-in-part of U.S. Application No. 12/486,992, filed June 18, 2009, and a continuation-in-part of U.S. Application No. 12/389,901, filed February 20, 2009, which is a continuation-in-part of U.S. Application No. 12/211,407, filed September 16, 2008, which is a continuation-in-part of U.S. Application No. 12/039,849, filed February 29, 2008, which: (1) claims the benefit of U.S. Provisional Application No. 60/953,620, filed on August 2, 2007, U.S. Provisional Application No. 60/947,813, filed on July 3, 2007, U.S. Provisional Application No. 60/911,297, filed on April 12, 2007, and U.S. Provisional Application No. 60/892,349, filed on March 1, 2007; (2) is a continuation-in-part U.S. Application No. 11/756,057, filed on May 31, 2007, which claims the benefit of U.S. Provisional Application No. 60/812,694, filed on June 9, 2006; (3) is a continuation-in-part of U.S. Application No. 11/971,390, filed on January 9, 2008, which is a continuation-in-part of U.S. Application No. 11/363,548, filed on February 27, 2006; and (4) is a continuation-in-part of U.S. Application No. 12/025,414, filed on February 4, 2008, which claims the benefit of U.S. Provisional Application No. 60/953,637, filed on August 2, 2007.

[0002] This application claims the benefit of U.S. Provisional Application No. 61/310,752 filed on March 5, 2010.

[0003] This application is also a continuation-in-part of U.S. Application No. 12/483,807, filed on June 12, 2009, which is a continuation-in-part of U.S. Application No. 12/371,096, filed on February 13, 2009, which is a continuation-in-part of U.S. Application No. 12/103,824, filed on April 16, 2008, which claims the benefit of U.S. Provisional Application No. 60/912,178, filed on April 17, 2007.

[0004] This application is also a continuation-in-part of U.S. Application No. 12/103,834, filed on April 16, 2008, which claims the benefit of U.S. Provisional Application No. 60/912,178, filed on April 17, 2007.

[0005] The disclosures of the above applications are incorporated herein by reference.

INTRODUCTION

[0006] Various patient specific templates and other guides are used for knee arthroplasty. The present teachings provide various patient-specific alignment guides, cutting guides and other instruments for the elbow joint.

SUMMARY

[0007] The present teachings provide a patient-specific alignment guide that includes a three-dimensional engagement surface customized in a pre-operating planning stage by computer imaging to closely mate and conform to a corresponding bone portion of a patient's elbow joint.

[0008] In one embodiment, the patient-specific-alignment guide defines a first longitudinal guiding bore aligned with a reference axis

associated with the elbow joint of patient when the alignment guide is mounted onto the corresponding bone portion.

[0009] In another embodiment, the patient-specific-alignment guide defines a guiding bore for guiding a pin along a reference axis and a guiding surface for guiding a blade for a bone-cut along a patient-specific resection plane, wherein the guiding bore and guiding surface are customized for the patient during a preoperative planning stage.

[0010] The present teachings provide a method of preparing an elbow joint for an implant. In one embodiment, the method includes mounting a patient-specific alignment guide including a three-dimensional engagement surface custom-made by computer imaging to a corresponding closely conforming bone portion of a patient's elbow joint, and inserting into the bone portion a first pin along an anatomic axis of the elbow joint through a first longitudinal guiding bore of the patient-specific alignment guide. The method also includes inserting into the bone portion a second pin through a second longitudinal guiding bore of the patient-specific alignment guide, and removing the patient-specific alignment guide without removing the first and second pins. The method further includes slidably mounting a first resection guide over the first and second pins, and resecting the bone portion for receiving an implant.

[0011] In another embodiment, the method includes mounting a patient-specific alignment guide including a three-dimensional engagement surface custom-made by computer imaging to a corresponding closely conforming bone portion of a patient's elbow joint. The method also includes inserting into the bone portion a first pin along an anatomic axis of the elbow

joint through a first longitudinal guiding bore of the patient-specific alignment guide, and resecting the bone portion along a first plane through a first longitudinal slot of the patient-specific alignment guide for receiving an implant.

[0012] The present teachings provide a medical device for an elbow joint including a cutting component and a guiding component. The cutting component includes a planar engagement surface for engaging or contacting a planar resected surface of a bone, a first elongated slot along a first plane perpendicular to the engagement surface for guiding a first planar resection and a second elongated slot along a second plane at an oblique angle relative the first plane for guiding a second planar resection at an oblique angle relative to the first planar resection. The cutting component also includes an aperture. The guiding component includes first and second longitudinal bores aligned along first and second reference axes for receiving first and second alignment pins engageable with the bone. The guiding component includes an extension slidably received through the aperture of the cutting component for orienting the first and second planes of the cutting component in pre-planned orientations relative to the first and second reference axes.

[0013] Further areas of applicability of the present teachings will become apparent from the description provided hereinafter. It should be understood that the description and specific examples are intended for purposes of illustration only and are not intended to limit the scope of the present teachings.

BRIEF DESCRIPTION OF THE DRAWINGS

[0014] The present teachings will become more fully understood from the detailed description and the accompanying drawings, wherein:

[0015] FIG. 1A is an anterior view illustrating the bones of a right elbow;

[0016] FIG. 1B is a posterior view illustrating the bones of a right elbow;

[0017] FIG. 2A is a perspective view of the Discovery[®] Elbow System for total elbow joint replacement commercially available from Biomet Orthopedics, Inc., Warsaw, Indiana, USA;

[0018] FIG. 2B is a perspective view of a Lateral Resurfacing Elbow (LRE[™]) system commercially available from Biomet UK, Ltd, Bridgend, South Wales, UK;

[0019] FIG. 3 is an environmental perspective view of a patient-specific alignment guide illustrated for the distal humerus according to the present teachings;

[0020] FIG. 4A is an environmental perspective view of a patient-specific guide illustrated for the distal humerus according to the present teachings;

[0021] FIG. 4B is a sectional of the patient-specific guide of FIG. 4A taken along line 4B-4B;

[0022] FIG. 4C is an environmental sectional view of an implant fitted to a resected elbow joint;

[0023] FIG. 5 is an environmental perspective view of a patient-specific alignment guide illustrated for the distal humerus according to the present teachings;

[0024] FIG. 6 an environmental sectional view of placement of first and second pins in locations determined by a patient-specific guide according to the present teachings;

[0025] FIGS. 7A and 7B are environmental perspective views illustrating a cutting guide supported on first and second lateral pins for performing a distal cut according to the present teachings;

[0026] FIG. 7C is a detail of a modular posterior cutting guide for performing a distal cut according to the present teachings;

[0027] FIG. 7D is a detail of a modular posterior cutting guide for performing a distal cut according to the present teachings;

[0028] FIGS. 8A and 8B are environmental perspective views illustrating a cutting guide supported on first and second lateral pins for performing an anterior cut and an angled posterior cut according to the present teachings;

[0029] FIG. 8C is an environmental sectional view illustrating a cutting guide supported on a distal resected surface and mounted on first and second lateral pins for performing an anterior cut and an angled posterior cut and the corresponding anterior and angled posterior cuts according to the present teachings;

[0030] FIG. 9 is an environmental sectional view illustrating a cutting guide supported on distal resected surface and mounted on first and

second lateral pins for performing an anterior cut and an angled posterior cut after according to the present teachings;

[0031] FIG. 10 is an environmental perspective view of a patient-specific alignment guide with first and second posterior pins illustrated for the distal humerus according to the present teachings;

[0032] FIG. 11 is an environmental perspective view of a cutting guide supported on first and second posterior pins for performing a distal cut according to the present teachings;

[0033] FIG. 12 is an environmental perspective view of a cutting guide supported on first and second posterior pins for performing an anterior cut and an angled posterior cut according to the present teachings;

[0034] FIG. 13 is an environmental sectional view of a patient-specific guide illustrated for the ulna of an elbow joint according to the present teachings;

[0035] FIG. 14A is an environmental sectional view of a patient-specific alignment guide illustrated for the olecranon fossa of the distal humerus of an elbow joint according to the present teachings;

[0036] FIG. 14B is an environmental perspective view of a patient-specific cutting guide illustrated for the olecranon fossa of the distal humerus according to the present teachings; and

[0037] FIG. 15 is an environmental sectional view of a patient-specific guide illustrated for the capitellum of the distal humerus according to the present teachings.

DESCRIPTION OF VARIOUS ASPECTS

[0038] The present teachings generally provide patient-specific surgical instruments that include, for example, alignment guides, drill guides, templates, cutting/resection guides for use in elbow joint replacement, elbow resurfacing procedures and other procedures related to the elbow joint or the various bones of the elbow joint. The patient-specific instruments can be used either with conventional implant components or with patient-specific implant components prepared with computer-assisted image methods. Computer modeling for obtaining three dimensional images of the patient's anatomy using MRI or CT scans of the patient's anatomy, the patient specific prosthesis components, and the patient-specific guides, templates and other instruments can be provided by various CAD programs and/or software available, for example, by Materialise USA, Ann Arbor, Michigan.

[0039] The patient-specific instruments and associated patient-specific implants disclosed herein can be generally formed using computer modeling based on the patient's 3-D anatomic image generated from image scans. The patient-specific instruments can have a three-dimensional engagement surface that is made to conformingly contact and match a three-dimensional image of the patient's bone surface (imaged selectively with associated soft tissues or without soft tissue, i.e. an actual bone surface), by the computer methods discussed above. The patient-specific instruments can include custom-made guiding formations, such as, for example, guiding bores or cannulated guiding posts or cannulated guiding extensions or receptacles that can be used for supporting or guiding other instruments, such as drill guides, reamers, cutters, cutting guides and cutting blocks or for inserting pins or other fasteners according to a surgeon-approved pre-operative plan.

[0040] In various embodiments, the patient-specific instruments can also include one or more patient-specific cutting guides for receiving and guiding a cutting blade at corresponding patient-specific resection orientations relative to a selected anatomic axis for the specific patient. The patient-specific instruments can also include guiding formations for guiding the implantation of patient-specific or off-the-shelf implants associated with the surgical procedure, such as humeral and ulnar implant components. The geometry, shape and orientation of the various features of the patient-specific instruments, as well as various patient-specific implants, if used, can be determined during the pre-operative planning stage of the procedure in connection with the computer-assisted modeling of the patient's anatomy. During the pre-operative planning stage, patient-specific instruments, custom, semi-custom or non custom implants and other non custom tools, can be selected and the patient-specific components can be manufactured for a specific-patient with input from a surgeon or other professional associated with the surgical procedure, as described in the commonly assigned and co-pending patent applications listed in the cross reference section and incorporated herein by reference.

[0041] In the following discussion, the terms "patient-specific", "custom-made" or "customized" are defined to apply to components, including tools, implants, portions or combinations thereof, which include certain geometric features, including surfaces, curves, or other lines, and which are made to closely conform as mirror-images or negatives of corresponding geometric features of a patient's anatomy obtained or gathered during a pre-operative planning stage based on 3-D computer images of the corresponding

anatomy reconstructed from image scans of the patient by computer imaging methods. Further, patient specific guiding features, such as, guiding apertures, guiding slots, guiding members or other holes or openings that are included in alignment guides, drill guides, cutting guides, rasps or other instruments or in implants are defined as features that are made to have positions, orientations, dimensions, shapes and/or define cutting planes and axes specific to the particular patient's anatomy including various anatomic or mechanical axes based on the computer-assisted pre-operative plan associated with the patient.

[0042] Referring to FIGS. 1A and 1B, anterior and posterior views of an elbow joint 70 are illustrated to highlight areas on which the patient-specific guides of the present teachings are adapted to conform to. The elbow joint 70, including subchondral bone with or without cartilage or other soft tissue depending on surgeon requirements/recommendation of a particular patient, is modeled preoperatively as three-dimensional computer image from a series of scans of the elbow joint 70 of a particular patient. As illustrated schematically for simplicity and without showing any soft tissue for further reference below, the elbow joint 70 includes the bone portions of the distal humerus 72, the proximal radius 74 and the proximal ulna 76. In the anterior view of FIG. 1A, the capitellum (capitulum humeri) is illustrated at 78, the trochlea at 80, and the lateral and medial epicondyles at 82, 84 respectively. In the posterior view of FIG. 1B, the olecranon fossa of the distal humerus 72 is illustrated at 86 and the olecranon of the proximal ulna is illustrated at 88.

[0043] Referring to FIGS. 2A and 2B, exemplary implants 100a, 100b for the elbow joint are illustrated. FIG. 2A illustrates an exemplary total

elbow arthroplasty implant 100a, commercially available from Biomet Orthopedics, Inc., Warsaw, Indiana, USA, as Discovery[®] Elbow System. The elbow arthroplasty implant 100a includes a spherical hinge 102 coupling a humeral component 104 and an ulnar component 106. The humeral component 104 includes a bowed stem 108, a cylindrical base 110 and an anti-rotation flange 112. The ulnar component 106 includes a stem 114 forming an anatomic anterior neck angle and a polyethylene insert 116.

[0044] FIG. 2B illustrates an exemplary elbow resurfacing implant 100b commercially available from Biomet UK, Ltd, Bridgend, South Wales, UK, as Lateral Resurfacing Elbow (LRE[™]) system. This implant 100b is modular and includes a radial head component 120 and a capitellar component 122 with optional implantation of one or both components. Details of the implantation techniques and surgical procedures for the implants are available in the manufacturers' websites.

[0045] Referring to FIG. 3, a patient-specific alignment guide 200 is illustrated. The patient-specific alignment guide 200 can be specific to portions of the lateral epicondyle 82 and/or capitellum 78 of the distal humerus 72 of the patient and includes a three-dimensional engagement surface 202, custom-made by computer imaging to conform to a corresponding portion of a patient's corresponding anatomy, such an area of the epicondyle or capitellum or other area of the distal humerus 72. The alignment guide 200 can include a patient-specific guiding feature 204, which can be computer modeled to be aligned with a reference axis, including an axis of rotation A of the elbow joint 70 of the patient. The guiding feature 204 can be a tubular or partially tubular structure with an elongated guiding bore 206 at a patient-specific orientation

and location for guiding a drill bit, a pin, or other tool to make a hole through the distal humerus 72 at the reference axis A. A guiding/alignment pin 220, such as a Steinmann pin, can be inserted into the distal humerus 72 through the guiding bore 206 when the alignment guide 200 is mounted on the distal humerus 72. It should be noted that because of the patient-specific nature of the engagement surface 202, the alignment guide 200 can fit in a unique position/orientation over the capitellum 78. In some embodiments, the alignment guide 200 can automatically align the guiding bore 206 along the reference axis A, which can also be an axis of rotation of the patient's elbow joint or any other axis.

[0046] Referring to FIGS. 4A and 4B, a patient-specific combined alignment and resection/cutting guide 300 for the distal humerus is illustrated. The combined guide 300 includes a three-dimensional patient-specific engagement surface 302, a tubular guiding feature 304 with an internal guiding bore 306 at a patient-specific orientation and location for a pin and a plurality of elongated guiding slots 308 for guiding a blade to perform the cuts required for inserting an elbow implant. In some embodiments, the guiding bore 306 can reference a selected anatomic axis of the joint or any other axis. Three exemplary guiding slots 308 for distal, anterior and posterior humeral cuts are shown. It should be noted that any number of desired guiding slots 308 may be included in the guide 300. An exemplary humeral implant 350, having inner surfaces 352 corresponding to distal, anterior and posterior humeral cuts, is shown in FIG. 4C.

[0047] Referring to FIGS. 5 and 6, a patient-specific alignment guide 400 for the lateral surface 77 of the distal humerus 72 is illustrated. The

alignment guide 400 includes a three-dimensional patient-specific engagement surface 402 for the lateral surface 77 of the distal humerus 72, optionally including portions of the lateral epicondyle or the capitellum or other anatomic landmarks of the lateral surface 77. The alignment guide 400 can also include a first guiding feature 404a with a first internal guiding bore 406a at a patient-specific orientation and location for a first alignment pin 220a. As discussed above, in some embodiments the guiding bore 406a can reference an anatomic axis (or first axis) A, such as an epicondylar axis or a rotation axis of the elbow joint of the specific patient, or any other selected axis. The alignment guide 400 can include a second guiding feature 404b with a second internal guiding bore 406b for a second alignment pin 220b referencing a second axis B parallel to the first axis A. The second alignment pin 220b can be provided for additional rotational stability and for supporting various resection instruments, as discussed below. The corresponding first and second alignment pins 220a, 220b extend from the lateral surface 77 toward the medial surface 79 of the distal humerus 72 and can be used for guiding osteotomy instruments or other instruments along patient specific orientations and locations of the axes A and B, as discussed below. The first and second guiding features 404a, 404b can be formed as a single integral (monolithic) structure as shown in FIG. 5, or as two separate elongated structures extending from the alignment guide 400.

[0048] After the first and second alignment pins 220a, 220b are fixed on the lateral surface 77 of the distal humerus 72, the alignment guide 400 is slid off the first and second alignment pins 220a, 220b and removed, while the first and second alignment pins 220a, 220b remain attached to the

distal humerus, as illustrated in FIG. 6. Alternatively, first and second holes 90a, 90b can be drilled or marked through the first and second guiding bores 406a, 406b for the first and second alignment pins 220a, 220b, the alignment guide 400 removed, and then the first and second alignment pins 220a, 220b inserted through the pre-drilled or pre-marked holes 90a, 90b.

[0049] Referring to FIGS. 7A and 7B, a posterior resection or cutting guide 500 can be mounted on and aligned by the first and second alignment pins 220a, 220b for performing a distal cut of the distal humerus from a posterior to an anterior surface of the distal humerus. The posterior cutting guide 500 can include a cutting component 502 oriented to abut against the posterior surface of the distal humerus and a guiding component 530 oriented for lateral placement relative to the distal humerus and slidably mounted over the first and second alignment pins 220a, 220b, as illustrated in FIG. 7A. The lateral-medial orientation is illustrated with an arrow LM and the posterior-anterior orientation is illustrated with arrow PA in FIG. 7A. The cutting and guiding components 502, 530 can be modularly or integrally connected via a connector 520, as discussed below.

[0050] The cutting component 502 can be in the form of a cutting block having opposite first and second (front and back/engagement) surfaces 520a, 510b, opposite side surfaces (distal and proximal) 510c, 510d, and opposite end surfaces (lateral and medial) 510e, 510f. The cutting component 502 can include one or more elongated slots 504 extending along the lateral-medial orientation for receiving a saw blade. The elongated slots 504 are automatically aligned along patient-specific positions determined during the preoperative planning stage for the patient when the posterior cutting guide

500 is mounted over the first and second alignment pins 220a, 220b. The cutting component 502 can also include a window elongated in the lateral-medial direction. The cutting component 502 can include a plurality of holes 506 that can be arranged in clusters for locking the cutting guide 500 with pins onto the distal humerus during the cutting operation.

[0051] The guiding component 530 can include a body 531 having first and second longitudinal guiding bores 532a, 532b slidably mounted over the first and second alignment pins 220a, 220b to orient the cutting component 502 in a patient-specific orientation and position for performing the distal cut as determined in the preoperative planning stage. Although the body 531 of the guiding component 530 can have any shape, such as a cylindrical or prismatic bar, some shapes allow the posterior cutting guide 500 to be used in both the right and left humerus without increasing the bulk or size of the components. An exemplary shape of the body 531 for right and left humerus is illustrated in FIG. 7A and includes first and second portions 534a, 543b coupled at an angle β defining a body 501 with an arrow-shaped cross-section. The first guiding bore 532a for the anatomic axis A is positioned at the juncture of the first and second portions 534a, 534b (apex of the angle β). The second guiding bore 534b is defined through the second portion 534b and a third guiding bore 532c is defined through the first portion 534a symmetrically to the second guiding bore 532b. The first and second guiding bores 532a, 532b can, thus, be used for the left humerus, while the first and third guiding bore 532a, 532c can be used for the right humerus in connection with the cutting component 502 which is symmetric about a medial-lateral axis, as illustrated in FIG. 2A.

[0052] As discussed above, the connector 520 can be integrally attached to the cutting and guiding components 502, 530, as illustrated in FIG. 7A. The connector 520 can be a polygonal bar for providing a clearance between the cutting and guiding components 502, 530. For example, the connector 520 can be L-shaped with a first end portion 520a coupled to cutting component 502 and a second end portion 520b coupled to the guiding component 530. Intermediate portions may be included for certain attachment configurations. The first end portion 520a can be attached to any of the surfaces 510e, 510c, 510d.

[0053] The connector 520 can also be removably coupled to the cutting component 502, as illustrated in FIGS. 7C and 7D. In one exemplary embodiment, the first end portion 520a of the connector can be removably coupled to one of the side or end surfaces 510e, 510f, 510c, 510d of the cutting component with T-slot or dovetail or rectangular slot or other quick connect/disconnect connection. FIG. 7C illustrates a T-slot connection at the lateral end surface 510e of the cutting component 502. A split T-shaped extension 522 of the first end portion 520a can be slidably received in a corresponding T-shaped slot 512 defined on lateral end surface 510e of the cutting component 502. A locking or set screw can be threaded through a bore 524 of the first end portion 520a and through the split T-extension 522 to lock the connection. The locking screw 526 can include an enlarged head 528 received in a corresponding recess 527 of the connector 520. Similarly, FIG. 7D illustrates a rectangular slot 511 slidably receiving a corresponding rectangular end 521 of the first portion 520a. A locking screw can be threaded through a bore first end portion 520a and into a corresponding

threaded hole 513 at the base of the rectangular slot 511. It will be appreciated that other slidable, snap or quick connect with locking options can be used to removably interconnect and lock the cutting component 502 and the guiding component 530 therebetween. The distal cut is performed with the cutting guide 500 assembled on the distal humerus.

[0054] Referring to FIGS. 8A-8C and 9, after a distal cut is made using the posterior cutting guide 500, the posterior cutting guide 500 can be slid off or otherwise removed from the first and second alignment pins 220a, 220b. A distal cutting guide 600 (FIGS. 8A-8C) or 600a, FIG. 9) can be mounted over the first and second alignment pins 220a, 220b on the distal resected surface 92 of the distal humerus 72. The distal cutting guide 600 can be made as an integral (monolithic) unit or can be modular including a cutting component 602 and a guiding component 630, as illustrated in FIGS. 8A-8C. The guiding component 630 can include first and second guiding bores 632a, 632b for slidably receiving the first and second alignment pins 220a, 220b. The guiding component 630 can also include an extension 634 for removably supporting the cutting component 602. The extension 634 can be oriented along a third axis C that is substantially perpendicular to the direction of the first and second parallel axes A and B of the alignment pins 220a, 220b. The distal cutting guide 600a of FIG. 9 includes a set screw 640 for locking the cutting component 602 to the guiding component 630.

[0055] The cutting component 602 can be shaped as a cutting block and include a first surface or bone engagement surface 604 and an opposite or second surface 606. The bone engagement surface 604 is substantially planar or flat for positioning the cutting component 602 on the distal resected

surface 92 of the distal humerus 72. The cutting component 602 can include a first elongated planar slot 608 oriented perpendicularly to or at any desired angle relative to the bone engagement surface 604 and a second elongated planar slot 610 at an oblique angle relative to the bone engagement surface 604 for guiding, respectively, a posterior angled cut 94 and an anterior cut 96. As illustrated in FIG. 8C, the first elongated planar slot 608 and the corresponding posterior angled cut 94 are oriented at an oblique angle γ relative to the third axis C. The angle γ is an acute angle, as illustrated in FIG. 8C. The second elongated planar slot 610 and the corresponding anterior cut 96 are oriented parallel to the third axis C and perpendicular to the first and second surfaces 604, 606. The cutting component 602 can include an opening 612 slidably receiving the extension 634 for coupling the cutting component 602 to the guiding component 630 and orienting the first and second elongated slots 608, 610 and the corresponding posterior angled cut 94 and anterior cut 96 in pre-planned orientations and positions relative to the first axis A, which is an anatomic axis for the elbow joint, as discussed above. The opening 612 and the cross-section of the extension 634 can be mating and keyed or have mating non-rotatable shapes, e.g., rectangular, oval or polygonal. In other embodiments, the opening 612 can have a circular or other rotatable shape. The cutting component 602 can also include a plurality of holes 614 for securing the cutting component 602 to the bone during resection.

[0056] In the procedures described above in connection with FIGS. 5-9, the first and second alignment pins 220a, 220b were placed through the lateral surface of the distal humerus 72 extending from the lateral toward the

medial direction. It is also possible to place the first and second alignment pins 220a, 220b posteriorly, i.e., from the posterior toward the anterior surface of the distal humerus 72, as illustrated in FIGS. 10-12. It will be appreciated that the selected axes A' and B' are different anatomic or reference axes than the first and second axes A and B and are oriented in the posterior-anterior direction. The axes A' and B' can be perpendicular to or at any other oblique angle relative to the rotation axis of the elbow joint. As described above, a patient-specific alignment guide 700 can assist in the placement of the first and second alignment pins 220a, 220b. The patient-specific alignment guide 700 includes a three-dimensional patient-specific engagement surface 702 for the posterior surface of the distal humerus 72, and a first and second guiding bores 704a, 704b designed during a preoperative planning stage and based on the patient's anatomy for orienting the first and second alignment pins 220a, 220b along predetermined directions of axes A' and B'. The patient-specific alignment guide 700 can also include a removable or permanently attached handle 710. Similar handles can be used with the other patient-specific alignment guides described herein.

[0057] Referring to FIG. 11, after the patient-specific alignment guide 700 is removed, a posterior resection/cutting guide 750 can be removably mounted over the first and second alignment pins 220a, 220b through corresponding apertures 752a, 752b. The posterior cutting guide 700 can include an elongating slot 754 for guiding the distal cut of the distal humerus 72. In another embodiment, the posterior cutting guide 750 can be combined with the patient-specific alignment guide 700, either integrally or by a modular connection (dovetail, T-slot, etc.). In this regard, the combined

cutting/alignment guide 700/750 can then engage the posterior surface of the distal humerus 72 with an engagement surface 758 which is patient-specific.

[0058] Referring to FIG. 12, after the distal cut is made, the posterior cutting guide 750 is removed and a distal cutting guide 800 is mounted on the resected distal surface of the distal humerus. Similarly to the distal cutting guide 600 discussed above in connection with FIGS. 8A-8C, the distal cutting guide 800 can include a cutting component 802 and a guiding component 830 with first and second bores 832a, 832b for slidably receiving the first and second alignment pins 220a, 220b. The cutting component 802 can include a first elongated planar slot 808 oriented obliquely relative to the reference axes A', B;' and a second elongated planar slot 810 oriented perpendicularly relative to the reference axes A', B;' for guiding, respectively, a posterior angled cut 94 and an anterior cut 96 (see FIG. 8C for exemplary cuts 94, 96). The cutting component 802 can include an opening 812 slidably receiving an extension 834 of the guiding component 830 and orienting the first and second elongated slots 808, 810 and the corresponding posterior angled cut 94 and anterior cut 96 in pre-planned orientations and positions relative to the reference axes A', B'. The opening 812 can be elongated to allow adjustment in the direction of the reference axes A' and B' and can be secured, after adjustment, with a blocking stop inserted in the opening 812 or with pins through the holes 814. It will be appreciated that a complete posterior angled cut 94 can be obstructed by the guiding component 830 in this configuration. Accordingly, after the posterior angled cut is initiated or partially resected, the entire cutting guide 800 and the first and second alignment pins 220a, 220b can be removed and the posterior angled cut 94

finished with a saw blade. Alternatively, the guiding component 830 the first and second alignment pins 220a, 220b can be removed while the cutting component 802 remains secured on the bone with pins through the holes 814 in its original mounted position defined by the first and second alignment pins 220a, 220b.

[0059] Referring to FIG. 13, a patient-specific alignment guide 850 is illustrated. The patient-specific alignment guide 850 is specific to the olecranon 88 of proximal ulna 76 of the patient and includes a three-dimensional engagement surface 852, custom-made by computer imaging to conform and nest to a corresponding portion of a patient's olecranon 88. The alignment guide 850 can include a guiding feature 854, computer modeled to be aligned with an anatomic axis A" of the elbow joint 70 of the patient. The guiding feature 854 can be a tubular or partially tubular structure with an elongated guiding bore 856 for guiding an alignment pin 220 into the proximal ulna 76 when the alignment guide 850 is mounted on the olecranon 88. Because of the patient-specific nature of the engagement surface 852, the alignment guide 850 can fit in a unique position/orientation over the olecranon 88 and automatically align the guiding bore 856 along the anatomic axis A". The alignment pin 220 can be used to reference the anatomic axis A" for additional bone preparation after the alignment guide 850 is removed.

[0060] Referring to FIG. 14A, a patient-specific posterior guide 900 for the olecranon fossa 86 of the distal humerus 72 is illustrated. The patient-specific guide 900 includes a three-dimensional engagement surface 902, custom-made by computer imaging to conform to a corresponding portion of a patient's olecranon fossa 86 (see FIG. 1B). The posterior guide 900 is

designed to reference an axis of rotation D and an intramedullary axis D'. The posterior guide can include a plurality of elongated saw blade slots 904 for resecting the trochlea (see FIG. 1A) in preparation for a humeral implant. The guide 900 can be secured to the bone with one or more pins.

[0061] Referring to FIG. 14B, a modular posterior guide 930 for the olecranon fossa 86 of the distal humerus 72 is illustrated. The modular posterior guide 900 is designed to reference an axis of rotation D and an intramedullary axis D'. The modular posterior guide 930 includes a patient specific cutting guide 910 removable coupled to a guiding component 920. The patient specific cutting guide 910 includes a three-dimensional engagement surface 912, custom-made by computer imaging to conform to a corresponding portion of a patient's olecranon fossa 86 (see FIG. 1B). The cutting guide 910 can include a plurality of elongated saw blade slots 914 for resecting the trochlea (see FIG. 1A) in preparation for a humeral implant. The cutting guide 910 is coupled to the guiding component 920 which is supported on the distal humerus with a rod or pin 922 along the intramedullary axis D'. Because of the patient-specific nature of the engagement surface 912, the cutting guide 910 can fit in a unique position/orientation over the olecranon fossa 86 and automatically align the rod 922 along the anatomic axis D'.

[0062] Referring to FIG. 15, a patient-specific alignment guide 950 is illustrated. The patient-specific alignment guide 950 is specific to the capitellum 78 of the distal humerus 72 of the patient and includes a three-dimensional engagement surface 952, custom-made by computer imaging to conform to a patient's capitellum 78 (or portion thereof). The alignment guide 950 can include a guiding feature 954 including an elongated guiding bore

956 for an alignment pin 220 (similar to the pin shown in FIG. 12), computer modeled to be aligned with an anatomic axis E of the elbow joint, such as an axis center on and perpendicular to the surface of the capitellum. The alignment pin 220 can be used to reference the anatomic axis E for additional bone preparation after the alignment guide 950 is removed.

[0063] The various patient-specific alignment guides can be made of any biocompatible material, including, polymer, ceramic, metal or combinations thereof. The patient-specific alignment guides can be disposable and can be combined or used with reusable non patient-specific cutting and guiding components.

[0064] The foregoing discussion discloses and describes merely exemplary arrangements of the present teachings. Furthermore, the mixing and matching of features, elements and/or functions between various embodiments is expressly contemplated herein, so that one of ordinary skill in the art would appreciate from this disclosure that features, elements and/or functions of one embodiment may be incorporated into another embodiment as appropriate, unless described otherwise above. Moreover, many modifications may be made to adapt a particular situation or material to the present teachings without departing from the essential scope thereof. One skilled in the art will readily recognize from such discussion, and from the accompanying drawings and claims, that various changes, modifications and variations can be made therein without departing from the spirit and scope of the present teachings as defined in the following claims.

CLAIMS:

1. A medical device for an elbow joint comprising:
a patient-specific alignment guide including a three-dimensional engagement surface customized in a pre-operating planning stage by computer imaging to closely mate and conform to a corresponding bone portion of a patient's elbow joint, the alignment guide defining a first longitudinal guiding bore aligned with a reference axis associated with the elbow joint of patient when the alignment guide is mounted onto the corresponding bone portion.
2. The medical device of claim 1, wherein the reference axis is parallel to an axis of rotation of the elbow joint.
3. The medical device of claim 1, wherein the reference axis is an axis of rotation of the elbow joint.
4. The medical device of claim 1, wherein the reference axis is an epicondylar axis of the elbow joint.
5. The medical device of any preceding claim, further comprising a second longitudinal guiding bore substantially parallel to the first bore.

6. The medical device of any preceding claim, wherein the three-dimensional engagement surface is shaped to conform to a capitellum surface of a distal humerus of the elbow joint.

7. The medical device of any of claims 1 to 5, wherein the three-dimensional engagement surface is shaped to conform to an olecranon fossa of a posterior surface of a distal humerus of the elbow joint.

8. The medical device of any of claims 1 to 5, wherein the three-dimensional engagement surface is shaped to conform to a surface of a proximal ulna of the elbow joint.

9. The medical device of claim 8, wherein the reference axis is a central axis of the ulnar canal.

10. The medical device of any preceding claim, wherein the patient-specific alignment guide includes a guiding surface for a planar resection.

11. The medical device of claim 10, wherein the guiding surface is an external surface of the patient-specific alignment guide.

12. The medical device of claim 10, wherein the guiding surface is surface defining by an elongated slot defined by the patient-specific alignment guide.

13. The medical device of any preceding claim, further comprising a plurality of guiding slots defined in the alignment guide for guiding planar cuts for receiving an elbow implant.

14. The medical device of claim 13, wherein the plurality of guiding slots includes three slots configured to guide corresponding distal, anterior and posterior humeral cuts.

15. The medical device of any preceding claim, further comprising a cutting guide including a cutting component and a guiding component, the guiding component slidably coupled to the cutting component, the guiding component slidably mountable to a pin passing through the first longitudinal bore of the patient-specific alignment guide.

16. A medical device for an elbow joint comprising:

a patient-specific alignment guide including a three-dimensional engagement surface customized in a pre-operating planning stage by computer imaging to closely mate and conform to a corresponding bone portion of a patient's elbow joint, the patient-specific-alignment guide defining a guiding bore for guiding a pin along a reference axis, the patient-specific alignment guide defining a guiding surface for guiding a blade for a bone-cut along a patient-specific resection plane, wherein the guiding bore and guiding surface are customized for the patient during a preoperative planning stage.

17. The medical device of claim 16, wherein the guiding surface is an exterior planar surface of patient-specific alignment guide.

18. The medical device of claim 16, wherein the guiding surface is a planar surface defined by an elongated through slot defined in the patient-specific alignment guide.

19. The medical device of claim 16, wherein the guiding surface comprises three slots defined in the patient-specific alignment guide corresponding to three resection cuts of the distal humerus.

20. The medical device of claim 16, wherein the guiding surface comprises at least one slot defined in the patient-specific alignment guide, the slot configured for a corresponding resection cut of the distal humerus.

21. A medical device comprising:

a cutting component including a planar engagement surface for engaging a resected surface of a bone, a first elongated slot along a first plane perpendicular to the engagement surface for guiding a first planar resection and a second elongated slot along a second plane at an oblique angle relative the first plane for guiding a second planar resection at an oblique angle relative to the first planar resection, the cutting component including an aperture; and

a guiding component including first and second longitudinal bores aligned along first and second reference axes for receiving first and second

alignment pins engageable with the bone, the guiding component including an extension slidably received through the aperture of the cutting component for orienting the first and second planes of the cutting component in pre-planned orientations relative to the first and second reference axes.

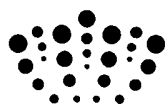

Application No: GB1116054.6

Examiner: Dr Matthew Parker

Claims searched: 1-20

Date of search: 20 December 2011

Patents Act 1977: Search Report under Section 17

Documents considered to be relevant:

Category	Relevant to claims	Identity of document and passage or figure of particular relevance
Y	1-9	WO2007/145937 A (BIOMET), whole document relevant
Y	1-9	US2008/114370 A (BIOMET), whole document relevant
Y	1-9	US2008/161815 A (BIOMET), whole document relevant
Y	1-9	US2003/009171 A1 (TORNIER), see especially Figure 2
Y	1-9	US2005/043806 A (COOK), see Figures 9 and 10
A	1	US5041117 A (ENGELHARDT)
A	1	US4927422 A (US4927422)

Categories:

X	Document indicating lack of novelty or inventive step	A	Document indicating technological background and/or state of the art.
Y	Document indicating lack of inventive step if combined with one or more other documents of same category.	P	Document published on or after the declared priority date but before the filing date of this invention.
&	Member of the same patent family	E	Patent document published on or after, but with priority date earlier than, the filing date of this application.

Field of Search:

Search of GB, EP, WO & US patent documents classified in the following areas of the UKC^X :

--

Worldwide search of patent documents classified in the following areas of the IPC

A61B

The following online and other databases have been used in the preparation of this search report

EPODOC, WPI

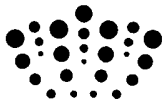

International Classification:

Subclass	Subgroup	Valid From
A61B	0017/17	01/01/2006
A61B	0017/15	01/01/2006