

[54] **COIN OPERATED APPARATUS**
 [75] Inventors: **Roger Propice**, Courbevoie; **Carlos Da Rocha**, Choisy-le-Roi, both of France

[73] Assignee: **Compagnie Industrielle Des Telecommunications Cit-Alcatel**, Paris, France

[22] Filed: **Oct. 20, 1971**

[21] Appl. No.: **190,847**

[30] **Foreign Application Priority Data**
 Oct. 23, 1970 France 7038391

[52] U.S. Cl. **194/99, 133/3 D, 194/100 A**

[51] Int. Cl. **G07f 3/00**

[58] Field of Search 133/3, 8; 194/100 A, 99; 209/78, 104, 87, 83, 97

[56] **References Cited**

UNITED STATES PATENTS

2,906,276 9/1959 Blanchette 133/3 R

1,964,966	7/1934	Troy	194/100 A
2,977,961	4/1961	Buchholz	133/3 R
811,559	2/1906	Hess	133/3 R
1,288,091	12/1918	McPheeters	133/3 R
3,242,932	3/1966	Becker	133/3 R
3,086,536	4/1963	Klopp	133/3 R
2,881,775	4/1959	Miller	133/3 R

FOREIGN PATENTS OR APPLICATIONS

1,154,219 6/1969 Great Britain

Primary Examiner—Robert B. Reeves
Assistant Examiner—Thomas E. Kocovsky
Attorney, Agent, or Firm—Sughrue, Rothwell, Mion, Zinn & Macpeak

[57] **ABSTRACT**

A coin collecting and counting device includes a turntable which directs coins by centrifugal force from a coin inlet to a coin path leading from the turntable periphery to respective coin outlets having coin validators for each type of coin along the path of coin movement.

7 Claims, 5 Drawing Figures

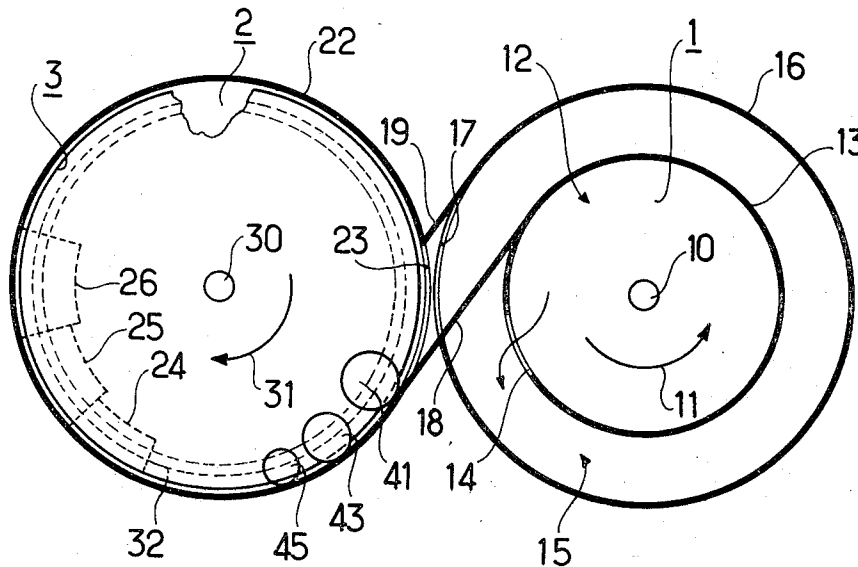

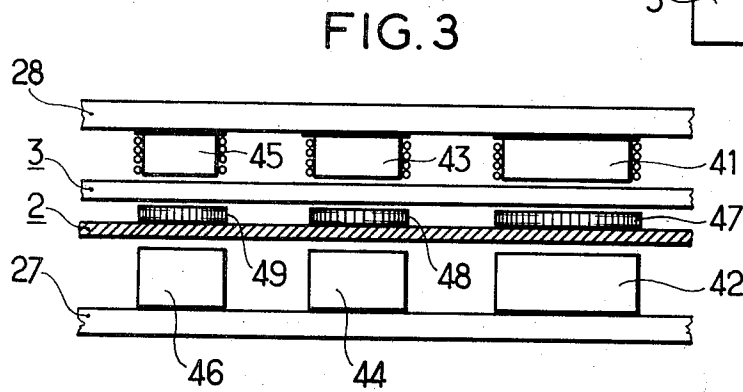
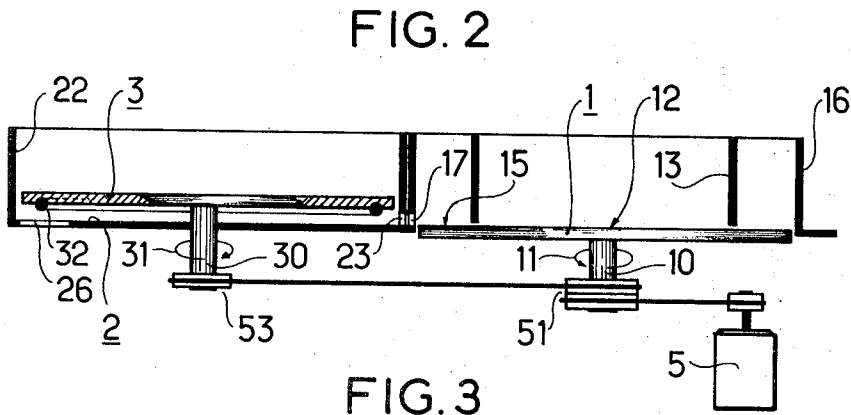
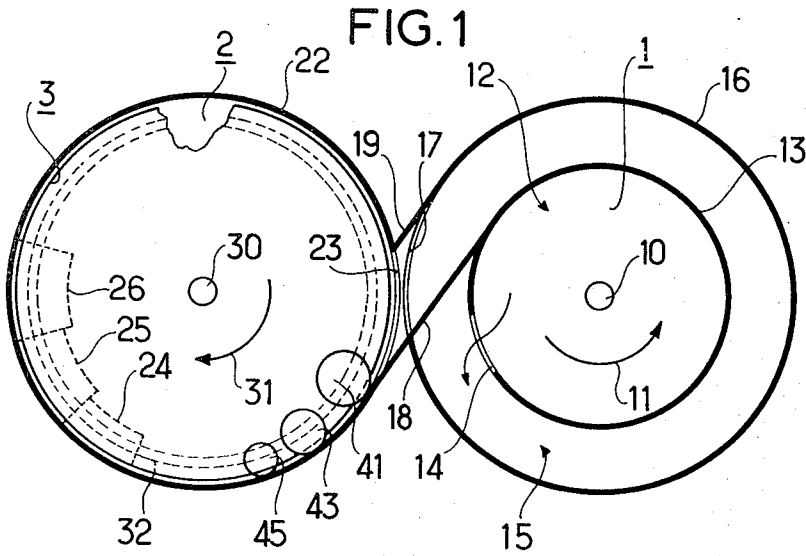

FIG. 4

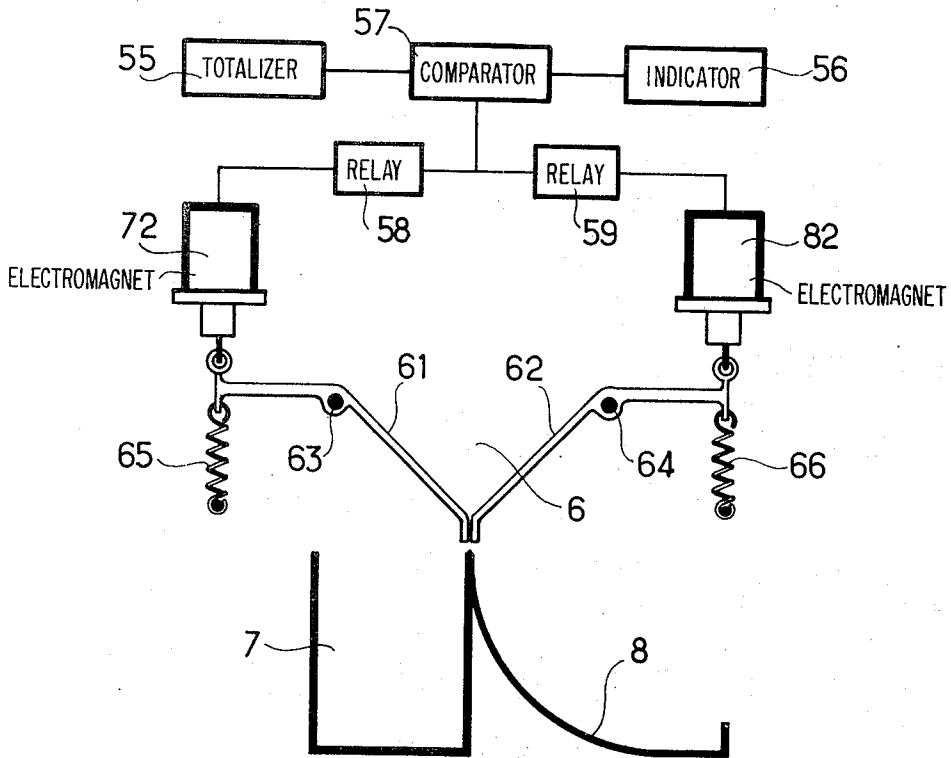
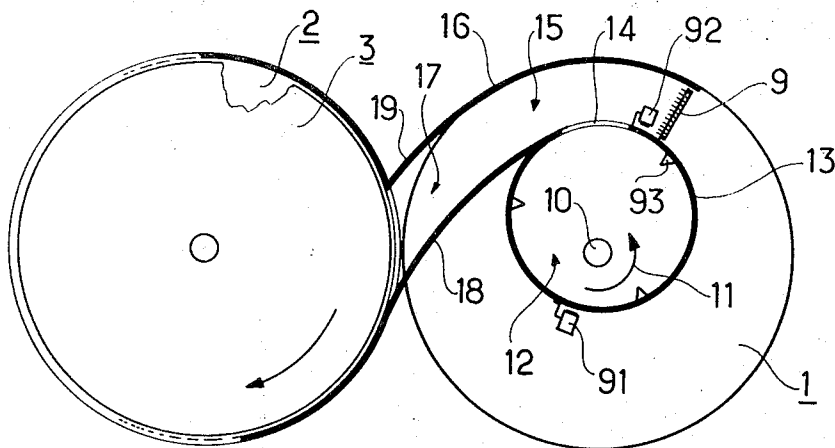

FIG. 5



COIN OPERATED APPARATUS

BACKGROUND OF THE INVENTION

FIELD OF THE INVENTION

The present invention concerns improvements in coin-operated apparatus, and is particularly although not exclusively applicable to machines for automatically collecting tolls payable on entry to a motorway.

Such machines must not only minimize the risk of people avoiding paying the toll but still using the motorway, while ensuring that there is no undue delay on entering the motorway, which might lead to traffic jams.

It will be appreciated that the invention is not limited to this application, but that it will find widespread application where reliable operation at high speed is required.

SUMMARY OF THE INVENTION

In accordance with the present invention, there is provided coin-operated apparatus including a substantially horizontal turntable onto which coins are directed from a coin inlet and from which they are centrifugally directed one at a time to a passage leading from the periphery of the first turntable to a coin path on which they are directed to respective coin outlets, a respective coin validation device for each type of coin being situated on the path of movement of the coins between the outlet of the passage and the first coin outlet and comprising a signal source and a detector of the signal.

The invention will now be described in more detail, by way of examples only and with reference to the accompanying diagrammatic drawings.

BRIEF DESCRIPTION OF THE DRAWINGS

FIG. 1 is a plan view of part of the apparatus of the present invention.

FIG. 2 shows that part of the apparatus in vertical cross-section.

FIG. 3 is an elevational sectional view of the coin validation devices of the apparatus.

FIG. 4 is a schematic view of a further part of the apparatus.

FIG. 5 shows an alternative construction of that part of the apparatus shown in FIG. 1.

DESCRIPTION OF THE PREFERRED EMBODIMENT

Referring to FIG. 1, a substantially horizontal first turntable 1 is driven in rotation about a vertical axis 10 in the direction of the arrow 11. A central zone 12 of this first turntable 1 is situated at the base of a coin-receiving chute (not shown) leading from a coin inlet (not shown) of the apparatus. Coins introduced into the apparatus through the coin inlet are directed onto the central portion 12 of the first turntable 1.

This central coin-receiving portion is limited by a fixed vertical annular wall 13 which is apertured at 14 to provide communication between the coin-receiving portion 12 and a passage indicated generally at 15 leading to a second turntable 2.

The aperture 14 has a length in the plane of the figure which is slightly greater than the diameter of the largest coin accepted by the apparatus. Its height perpendicular to the plane of the figure is slightly greater than the thickness of the thickest acceptable coin.

As coins fall onto the central portion 12, they are centrifugally urged against the fixed wall 13, eventually passing through aperture 14 into the passage 15.

The passage 15 comprises part of the peripheral region of the turntable 1, and is limited on one side by the fixed wall 13 and on the other side by a fixed outer wall 16. The inner wall 13 is continued by a tangential wall portion 18 and the outer wall 16 by a tangential portion 19 parallel to portion 18. These extend the passage 15 to the periphery of a disc 2.

After passing through the aperture 14, each coin is carried around the periphery of the first turntable 1 and is then directed centrifugally between wall portion 18 and 19 onto the disc 2. Peripheral portions 17 and 23 of the turntable 1 and disc 2 respectively, are closely adjacent.

The coin-receiving chute (not shown) is suitably arranged to be readily detachable, and to this end may be attached to the apparatus by means of a magnetic coupling. Thus where the apparatus is used for controlling entry of vehicles to a motorway or the like, should part of one vehicle strike the coin-receiving chute, it will be readily detached from the apparatus without damaging the latter.

Referring to FIGS. 1 and 2, above the disc 2, which is nonrotatable, is a second turntable 3. This is driven in rotation about an axis 30 in the direction shown by arrow 31, that is to say in the opposite direction to that in which turntable 1 rotates. On its lower face, that facing the disc 2, the turntable 3 is provided with a peripheral elastic loop 32 which is intended to drive coins on the disc 2 around its periphery, pressing elastically against the upper surface of each coin. As it leaves the passage 15, each coin arrives on the periphery of the disc 2, is engaged by the elastic loop 32, and begins to move around the disc periphery. This is limited by a vertical annular wall 22 which is apertured at 23 to permit entry of the coins. The outer annular wall 16 associated with turntable 1 is similarly apertured at 17.

It will be supposed that the apparatus is able to distinguish between and accept three types of coins. Consequently, the disc 2 defines three coin outlets 24, 25, and 26, one for each type of coin. These are situated on the periphery of the disc 2 at an appropriate distance from the outlet of the passage 15. Between this outlet and the first coin outlet 24 are disposed three coin validation devices 41, 43 and 45, one for each type of coin.

Turntable 1 carries a pulley 51 and is driven via a belt by a motor 5. A second belt on the pulley 51 is coupled to a pulley 53 carried by the turntable 3. The speed of rotation of the turntable 3 is suitably slightly greater than that of turntable 1.

Referring to FIG. 3, coins 47, 48 and 49 are shown on the disc 3 and progressively decrease in diameter. It will be supposed that the coins are of a magnetic material. Above the disc 2 and turntable 3, on a support 28 are mounted electromagnets 41, 43 and 45 incorporating magnetic cores whose outside diameters are substantially equal to those of the three types of coins. Directly below disc 2, is situated a respective electromagnetic detector on a support 27. These detectors are referenced at 42, 44 and 46.

When the electromagnets are energized with an alternating current, the alternating magnetic flux passes through the turntable 3 and disc 2, which are made of an appropriate material to permit such passage, to gen-

erate in the respective detectors a signal depending on the nature of the coin passing between the electromagnet and the detector. The strength of this signal will depend on the diameter and thickness of the coin, its material and so on.

It will be appreciated that where the coins are non-magnetic, the validation devices will comprise other forms of signal source with appropriate detectors. French Pat. No. 1,465,636 and Canadian Pat. No. 1,154,219 disclose typical non-magnetic validation devices. With metallic coins, for example, devices operating by detecting Foucault currents in the coins may be used.

Whatever type of detector is used, if its output during the passage of a coin lies between two predetermined values, that coin will be taken to be of the value associated with that detector. If the signal lies outside these two values, the coin will be noted as having another value, and may, of course, be recognized by one of the other two detectors.

The detectors may each be connected to a device for recording the total value of the coins of that type passing it in a given period, the three such devices being connected to a totalizer indicating the total value of all three types of coins.

A further check on the coins is provided by the coiner 24, 25 and 26. The radial width of these progressively increase, that of the first 24 being slightly greater than the diameter of the smallest coin 49, that is the next 25 slightly greater than the middle-size coin 48, and that of the last 26 slightly greater than the largest coin 47. As will be apparent from FIG. 1, the largest coins pass over outlets 24 and 25 and drop through outlet 26, the middle-size coins pass over outlet 24 and drop into outlet 25, and the smallest coins drop into outlet 24. Any larger coins will pass over all three outlets and remain on the disc 2. Means for detecting and removing such coins may be provided if required.

As coins will generally begin to drop through the coin outlets before the totalizer has indicated that their total value is correct, each outlet is associated with a respective temporary coin store. These hold the coins from each outlet until their total value has been checked, then passing the accumulated coins to a permanent store or to a refund outlet of the apparatus, from which they may be retrieved by the person inserting them in the apparatus.

FIG. 4 shows one such temporary store. It will be appreciated that three of these are required in the present example, one for each type of coin.

The coins fall into a space 6 defined between pivoted plates 61 and 62. These plates are pivoted about respective horizontal axis 63 and 64, have at their edges opposite to the axis flanges which, with the plates in a "storage" position contact one another to close the space 6. The plates 61 and 62 are biased into this storage position by respective springs 65 and 66.

Plate 61 may be rotated clockwise (as seen in the Figure) about its axis 63 by an electromagnet 72. On such rotation, the space 6 communicates with a coin-receiving hopper 7, into which the coins accumulated in the space 6 naturally fall.

Plate 62 is rotatable anticlockwise (as seen in the Figure) about its axis 64, by an electromagnet 82 so allowing the coins in space 6 to fall into a return chute 8.

The totalizer is represented at 55 and is connected with an element 56 indicating the total amount which

should be inserted to the apparatus to achieve the desired result to a comparator 57. When the totalizer value coincides with the required value, a relay 58 energizes electromagnet 72 to accept the coin. If the final totalized value does not coincide with the required value, or if it exceeds it, a relay 59 energizes electromagnet 82, to pass the coin to the return chute 8.

The cash box 7 may be common to all three temporary coin stores, constituting the permanent coin store. The return chute 8 may also be common to all three temporary stores, or each store may have its own chute, the three chutes leading to a common outlet.

FIG. 5 shows a modified form of the arrangement of the turntable 1 and the disc 2. Elements common to FIGS. 1 and 5 carry the same reference numerals.

The central coin-receiving portion 12 on turntable 1 is eccentric with respect to the turntable axis 10. Furthermore, that portion of the periphery of turntable 1 forming part of the passageway 15 is very much shorter than is the case in FIG. 1, the aperture 14 being situated closely adjacent the wall portions 18 and 19. The passageway 15 is therefore very short.

The combination of the eccentric coin-receiving portion 12 and the short passage 15 effects a considerable reduction in the time required for a coin reaching the turntable 1 to pass to the disc 2.

This arrangement may be further modified by having the central coin-receiving zone concentric with the turntable axis 10, but having only the base of the coin-receiving portion 12 rotatable. In this arrangement, the passage 15 must be made as short as possible.

Returning to the case illustrated in FIG. 5, where the whole turntable 1 is rotatable, a fixed brush 9 is mounted between walls 13 and 16 immediately upstream (in the sense of rotation of the turntable 1) of the aperture 14. This continually sweeps the turntable surface 1, so that the floor of the passage 15 is continually kept clean. A similar brush may be provided in the arrangement shown in FIG. 1, being mounted immediately adjacent the wall portion 18, on its downstream side in the sense of rotation of the turntable.

The brush may be replaced by any other suitable cleaning means, such as a blast of compressed air for example.

The apparatus is provided with a light source 91 mounted opposite a photo-sensitive element 92, the source 91 directing light through an aperture in wall 13, across the coin-receiving portion 12, through a further aperture in the wall 13 onto the element 92. These apertures and the light source and photo-sensitive element are suitably arranged so that coins lying flat in the coin-receiving portion 12 do not obstruct the beam, but that any object whose height exceeds the thickness of the thickest coin acceptable to the apparatus will interrupt the beam to provide an indication of its presence. The apparatus may then be provided with a system (not shown) for removing any such object. This might include, for example, a pivoted portion of the wall 13, immediately upstream of which will be mounted a swinging arm or like device for pushing any such object out of the coin-receiving portion 12 through the opened panel. Means would suitably be provided for returning any coins accidentally removed from portion 12 to the person currently using the apparatus.

Alternately, the ejector system may be so arranged that it does not operate until a complete cycle is finished, so that no coins should be present in portion 12.

In another alternative ejector arrangement, more particularly suitable for the system of FIG. 1, the coin exit slot 14 is replaced by a cutout whose length in the plane of the Figure is greater than the diameter of the largest coin but less than the separation of walls 13 and 16, and whose height perpendicular to this plane is as large as practicable. Consequently, objects larger than the coins but small enough to move along passage 15 leave the coin-receiving portion 12 and enter the passage.

A portion of the outer wall 16 then has an aperture whose length in the plane of the Figure is at least equal to that of the cut-out and which does not extend quite to the turntable surface. Adjacent this aperture is a deflecting arm or the like which is high enough above the turntable surface to allow coins to pass beneath it but arranged to push any larger objects out through the aperture, over the sill extending from the bottom of the aperture to the turntable surface and serving to retain the coins in the passage 15.

It may happen from time to time that a coin falls onto the coin-receiving portion 12 in such a way that it is pressed vertically against the wall 13, with its edge rolling or sliding on the turntable 1. The internal surface of the wall 13 is therefore suitably provided with projections 93 shaped so as to knock over any such coin to lie horizontally on the turntable 1. These projections 93 are suitably mounted above the turntable 1 at a distance slightly greater than the thickness of the thickest coin acceptable to the apparatus.

The coin chute (not shown) leading from the coin inlet to the coin-receiving portion 12 of the turntable 1 may be provided with a grill the apertures of which are slightly larger than the largest coin acceptable to the apparatus. The grill is suitably a two-level one, the two grill sections being separated by a distance slightly greater than the diameter of the largest coin. The chute or the grill may be vibrated. Consequently, all coins of the appropriate size should eventually pass through the grill to the coin-receiving portion 12 of the turntable 1, any larger coins or other objects remaining in the chute supported by the grill. Means may be provided for retrieving any such large coins, and for removing any such objects from the chute.

It will be appreciated that various further modifications may be made to the apparatus, depending on the particular application in each case. For example, where used for automatically receiving tolls, the indicator 56 will in general need to display only one value, that of the fixed toll. In other applications, where the apparatus is required to accept various amounts, the indicator 56 will be arranged to display the particular amount associated with a particular function. For example, if the apparatus were to authorize parking for one hour or two hours, the selection of this period by the user of the apparatus would cause the element 56 to display the appropriate sum to the comparator 57.

While, in this specification, the apparatus has been referred to as coin-operated, it will be appreciated that the invention is equally applicable to token-operated apparatus, that is to say, apparatus which is operated by tokens of one sort or another which must be inserted into the apparatus in the appropriate combination to

secure a given function.

What is claimed is:

1. A coin operated apparatus comprising:
 - a substantially horizontal, first turntable onto which coins are directed and from which they are centrifugally directed,
 - a fixed horizontal surface adjacent said first turntable and generally coplanar therewith,
 - a second rotatable turntable overlying said fixed horizontal surface, spaced slightly from said horizontal surface, and positioned adjacent said first rotatable turntable,
 - a fixed annular wall surrounding both turntables, opposed slots within the sides of said wall permitting passage of said coins from said first turntable to a position on said fixed horizontal surface, beneath said second rotatable turntable adjacent the periphery thereof,
 - means for rotating both turntables,
 - means carried by said second turntable adjacent the periphery thereof for pressing coins passing through said slots between said second turntable and said fixed surface and to drive said coins angularly in the direction of said second turntable rotation and into contact with the wall surrounding the periphery of the second turntable,
 - a plurality of coin outlets within said fixed horizontal surface downstream from said annular slot of said fixed annular wall surrounding said second turntable for respectively receiving coins of a given type, and
 - coin validation devices for each type of coin fixedly situated, in sequence, along the path of movement of said coins between said slots and the first coin outlet, in operative relationship with said moving coins and with each device including a signal source and detector of the signal.
2. The apparatus as claimed in claim 1, wherein each signal source comprises an electromagnet disposed above the path of movement of the coins.
3. The apparatus as claimed in claim 1, wherein the passage includes at least part of the peripheral region of the first turntable outside the annular wall and means for cleaning the peripheral first turntable surface at a point upstream of that at which the coins pass onto it.
4. The apparatus as claimed in claim 3, wherein the cleaning means include a fixed brush.
5. The apparatus as claimed in claim 1, wherein the first turntable has a central coin-receiving portion limited by a fixed inner annular wall, said wall being apertured to provide communication between the coin-receiving portion and the passage inlet.
6. The apparatus as claimed in claim 5, wherein the coin-receiving portion of the first turntable is eccentric with respect to the turntable axis of rotation.
7. The apparatus as claimed in claim 6, wherein the internal surface of the inner annular wall is provided with projections whose distance from the first turntable surface is slightly greater than the thickness of the thickest coin accepted by the apparatus.

* * * * *