

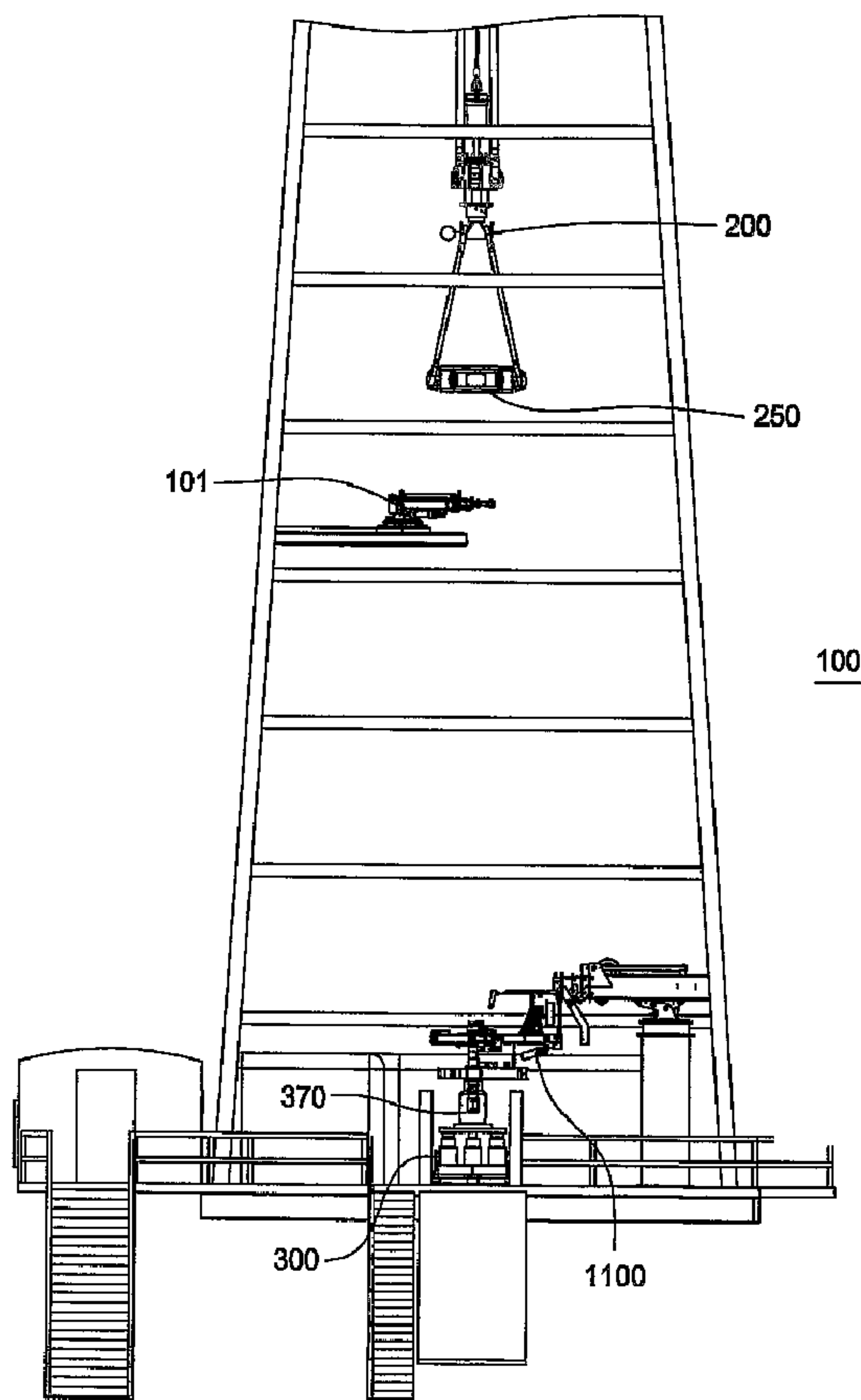

(86) Date de dépôt PCT/PCT Filing Date: 2004/04/05
 (87) Date publication PCT/PCT Publication Date: 2004/10/21
 (45) Date de délivrance/Issue Date: 2010/02/16
 (85) Entrée phase nationale/National Entry: 2005/09/23
 (86) N° demande PCT/PCT Application No.: US 2004/010442
 (87) N° publication PCT/PCT Publication No.: 2004/090279
 (30) Priorité/Priority: 2003/04/04 (US60/460,193)

(51) Cl.Int./Int.Cl. *E21B 19/06* (2006.01),
E21B 19/10 (2006.01)
 (72) Inventeurs/Inventors:
 MCDANIEL, GARY, US;
 THOMAS, ALLEN KEITH, JR., US;
 CUMMINS, PAT, US;
 HILL, TROY, US;
 CUMMINS, TRACY, US;
 BOUTWELL, DOYLE, US;
 HAYES, MICHAEL, US
 (73) Propriétaire/Owner:
 WEATHERFORD/LAMB, INC., US
 (74) Agent: DEETH WILLIAMS WALL LLP

(54) Titre : PROCÉDE ET APPAREIL DE MANIPULATION DE MATERIEL TUBULAIRE POUR Puits DE FORAGE
 (54) Title: METHOD AND APPARATUS FOR HANDLING WELLBORE TUBULARS



(57) Abrégé/Abstract:

Aspects of the present invention provide a tubular handling system for handling wellbore tubulars. In one aspect, the present invention provides a tubular handling system adapted to retain a tubular without damaging the outer surface of the tubular. In

(57) Abrégé(suite)/Abstract(continued):

another aspect, the present invention provides a method of connecting tubulars by remotely controlling the connection process, including joint compensation, alignment, make up, and interlock. In one embodiment, the tubular handling system comprises an elevator (50) adapted to support a tubular utilizing a first portion of an upset of the tubular and a spider (70) adapted to support the tubular utilizing a second portion of the upset. In another embodiment, at least one of the elevator and the spider is remotely controllable. In yet another embodiment, the tubular handling system comprising a joint compensator system (200) adapted to provide fluid communication to the elevator during rotation of the tubular.

(12) INTERNATIONAL APPLICATION PUBLISHED UNDER THE PATENT COOPERATION TREATY (PCT)

(19) World Intellectual Property
Organization
International Bureau



(43) International Publication Date
21 October 2004 (21.10.2004)

PCT

(10) International Publication Number
WO 2004/090279 A1

(51) International Patent Classification⁷: **E21B 19/06,**
19/10

(21) International Application Number:
PCT/US2004/010442

(22) International Filing Date: 5 April 2004 (05.04.2004)

(25) Filing Language: English

(26) Publication Language: English

(30) Priority Data:
60/460,193 4 April 2003 (04.04.2003) US

(71) Applicant (for all designated States except US): **WEATHERFORD/LAMB, INC.** [US/US]; 515 Post Oak Boulevard, Suite 600, Houston, TX 77027 (US).

(72) Inventors; and

(75) Inventors/Applicants (for US only): **MCDANIEL, Gary**

[US/US]; 11909 Spencer Road, FM 529, Houston, TX 77041 (US). **THOMAS, Allen, Keith, Jr.** [US/US]; 11909 Spencer Road, FM 529, Houston, TX 77041 (US). **CUMMINS, Pat** [US/US]; 11909 Spencer Road, FM 529, Houston, TX 77041 (US). **HILL, Troy** [US/US]; 11909 Spencer Road, FM 529, Houston, TX 77041 (US). **CUMMINS, Tracy** [US/US]; 11909 Spencer Road, FM 529, Houston, TX 77041 (US). **BOUTWELL, Doyle** [US/US]; 11909 Spencer Road, FM 529, Houston, TX 77041 (US). **HAYES, Michael** [US/US]; 109 Thornwood Circle, Lafayette, LA 70503 (US).

(74) Agents: **PATTERSON, William, B.** et al.; Moser, Patterson & Sheridan, L.L.P., 3040 Post Oak Boulevard, Suite 1500, Houston, TX 77056 (US).

(81) Designated States (unless otherwise indicated, for every kind of national protection available): AE, AG, AL, AM, AT, AU, AZ, BA, BB, BG, BR, BW, BY, BZ, CA, CH, CN, CO, CR, CU, CZ, DE, DK, DM, DZ, EC, EE, EG, ES, FI,

[Continued on next page]

(54) Title: METHOD AND APPARATUS FOR HANDLING WELLBORE TUBULARS

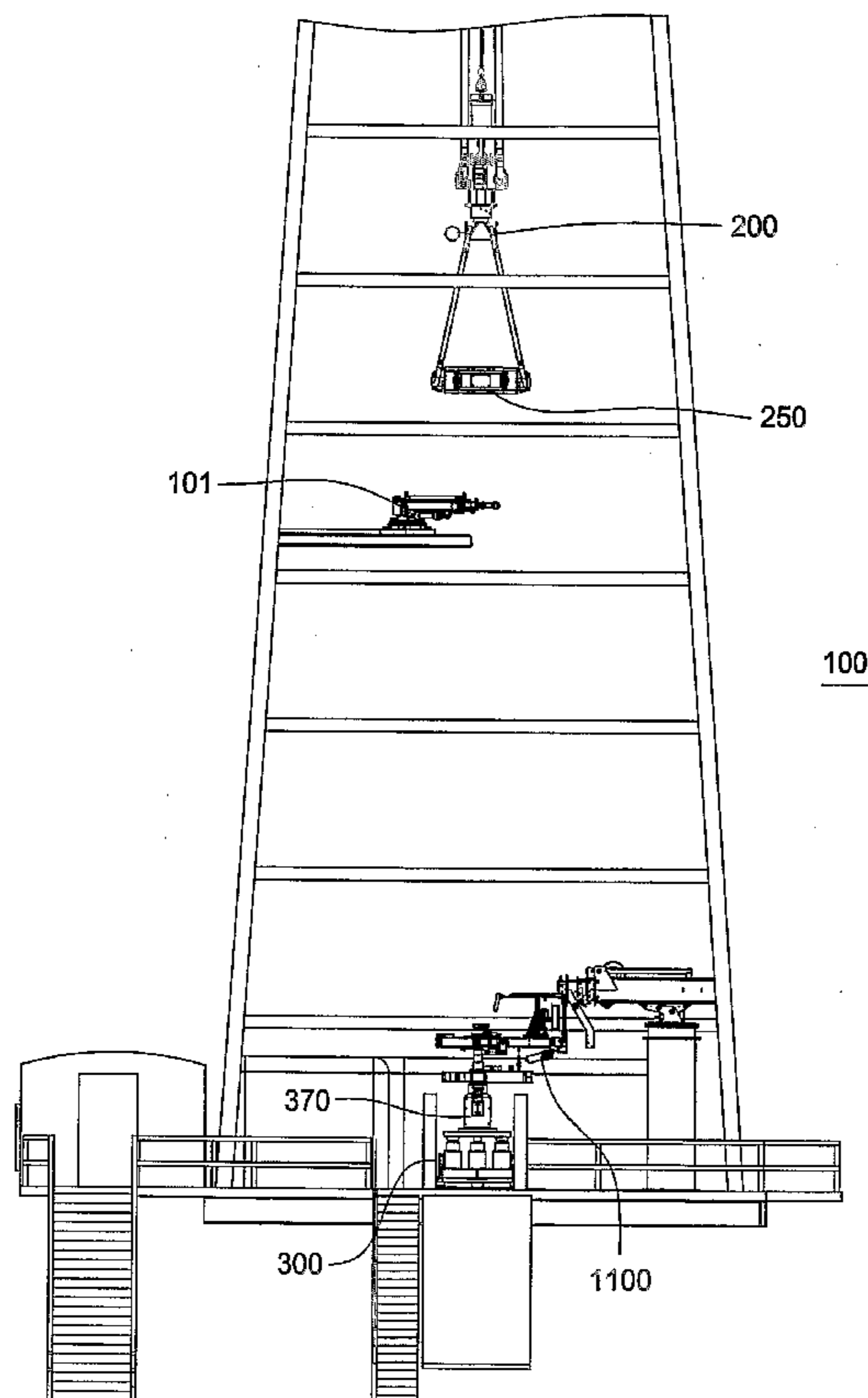

(57) Abstract: Aspects of the present invention provide a tubular handling system for handling wellbore tubulars. In one aspect, the present invention provides a tubular handling system adapted to retain a tubular without damaging the outer surface of the tubular. In another aspect, the present invention provides a method of connecting tubulars by remotely controlling the connection process, including joint compensation, alignment, make up, and interlock. In one embodiment, the tubular handling system comprises an elevator (50) adapted to support a tubular utilizing a first portion of an upset of the tubular and a spider (70) adapted to support the tubular utilizing a second portion of the upset. In another embodiment, at least one of the elevator and the spider is remotely controllable. In yet another embodiment, the tubular handling system comprising a joint compensator system (200) adapted to provide fluid communication to the elevator during rotation of the tubular.

WO 2004/090279 A1

WO 2004/090279 A1

GB, GD, GE, GH, GM, HR, HU, ID, IL, IN, IS, JP, KE, KG, KP, KR, KZ, LC, LK, LR, LS, LT, LU, LV, MA, MD, MG, MK, MN, MW, MX, MZ, NA, NI, NO, NZ, OM, PG, PH, PL, PT, RO, RU, SC, SD, SE, SG, SK, SL, SY, TJ, TM, TN, TR, TT, TZ, UA, UG, US, UZ, VC, VN, YU, ZA, ZM, ZW.

(84) Designated States (*unless otherwise indicated, for every kind of regional protection available*): ARIPO (BW, GH, GM, KE, LS, MW, MZ, SD, SL, SZ, TZ, UG, ZM, ZW), Eurasian (AM, AZ, BY, KG, KZ, MD, RU, TJ, TM), European (AT, BE, BG, CH, CY, CZ, DE, DK, EE, ES, FI, FR, GB, GR, HU, IE, IT, LU, MC, NL, PL, PT, RO, SE, SI, SK,

TR), OAPI (BF, BJ, CF, CG, CI, CM, GA, GN, GQ, GW, ML, MR, NE, SN, TD, TG).

Published:

- *with international search report*
- *before the expiration of the time limit for amending the claims and to be republished in the event of receipt of amendments*

For two-letter codes and other abbreviations, refer to the "Guidance Notes on Codes and Abbreviations" appearing at the beginning of each regular issue of the PCT Gazette.

METHOD AND APPARATUS FOR HANDLING WELLBORE TUBULARS

BACKGROUND OF THE INVENTION

Field of the Invention

5 The present invention relates to methods and apparatus of handling tubulars in and around a wellbore. More particularly, the invention relates to methods and apparatus to facilitate the formation of tubular strings. More particularly still, the invention relates to apparatus and methods for remote controlling the tubular connection process. More particularly still, the invention relates to methods and apparatus for supporting a string of
10 tubular riser for use between an offshore oil and gas platform and the ocean floor.

Description of the Related Art

 Wells are drilled and produced using strings of tubular that are threaded together. For example, wellbore are formed by disposing a drill bit at the end of a drill string. Due to the torsional forces present when rotating a bit at the end of the string that may be
15 thousands of feet long, the connection in drill string include a shoulder that can be torqued to a certain value. Other tubulars that line a borehole or serve as a fluid path for production fluids have a simpler threaded connection that only has to be fluid tight.

 With the advent of offshore drilling, a riser is commonly used to isolate drill string or production tubing from the ocean water. Riser is relatively large diameter tubing that
20 extends between an offshore rig floor and a wellhead at the ocean floor. Because the well is sometimes in hundreds of feet of water, riser can be hundreds of feet long and must bend and sway with the ocean current and in some cases, with the movement and drift of a platform at the surface. In addition to its relatively large diameter, riser typically has a large upset portion at one end where it is threadedly connected to another piece of riser to
25 form a string.

 Due to its function of providing isolation between possible hazardous material and the ocean, it is desirable not to damage, scratch, or mar the outer surface of riser with

tongs or other gripping devices that are typically used to date on a rig floor to connect sequential pieces of tubular pipe. For example, tubular strings are made today at a well site with the use of an elevator that can grasp a piece of tubular, lift it above the well center, and lower it into a threaded portion of another tubular extending from the well.

5 Once the tubulars are connected, the elevator then lowers the entire string to a position where it can be grasped by another gripping apparatus known as a spider.

At any time, either the spider or the elevator or both must be able to retain the string. The prior art elevators and spiders necessarily grasp the outer diameter of the tubulars in order to retain them axially. The spiders and elevators often use a die to
10 enhance their ability to grip the tubulars. However, the die tends to damage, scratch, or mar the outer surface of the tubular body. While the collateral damage to the outside of the tubulars is of little concern with liner or casing, it is often unacceptable with riser.

There is a need therefore, for a method and apparatus for handing tubulars at a well that does not result in damage to the outer surface of the tubulars. There is also a need
15 for remotely controlling the tubular handling or connection process. There is a further need for a method and apparatus that permits the formation of tubular strings without utilizing the outer surface of the tubulars for axial retention.

SUMMARY OF THE INVENTION

Aspects of the present invention provide a tubular handling system for handling
20 wellbore tubulars. In one aspect, the present invention provides a tubular handling system adapted to retain a tubular without damaging the outer surface of the tubular. In another aspect, the present invention provides a method of connecting tubulars by remotely controlling the connection process, including joint compensation, alignment, make up, and interlock.

25 In one embodiment, the tubular handling system comprises a first support member adapted to support a tubular utilizing a first portion of an upset of the tubular and a second support member adapted to support the tubular utilizing a second portion of the upset. In another embodiment, at least one of the first support member and the second support

member is remotely controllable. In yet another embodiment, the first and second support members are adapted to support the tubular at the same time. Preferably, the tubular comprises a riser.

5 In another aspect, the tubular handling system further comprises a joint compensator.

In another aspect still, the tubular handling system further comprises a rotary seal adapted to provide communication between the first support member and a controller. The rotary seal allows a fluid to be transmitted to the first support member during rotation of the tubular.

10 In another aspect still, the tubular handling system further comprises a rotary table for supporting the second support member. Preferably, the rotary table is adapted to absorb a force experienced by the second support member. In one embodiment, the rotary table comprises a polyurethane layer. In another embodiment, the rotary table comprises one or more piston and cylinder assemblies. In another aspect, the rotary table
15 is remotely controllable between an open position and a closed position.

In another aspect still, the tubular handling system further comprises an interlock system for ensuring the tubular is retained by at least one of the first support member and the second support member.

20 In another aspect still, the tubular handling system further comprises a tubular guide member for positioning the tubular. In one embodiment, the tubular guide member comprises a conveying member and a gripping member, wherein the conveying member moves the gripping member into engagement with the tubular.

In another aspect still, the tubular handling system further comprises a tong assembly for connecting the tubular with a second tubular.

25 In another aspect still, the tubular handling system further comprises a tong positioning device. In one embodiment, the tong positioning device comprises a single extendable beam having variable length. In another embodiment, the tong positioning

device comprises a movable frame. In yet another embodiment, the tong positioning device comprises a flexible chain provided with compression members and a flexible locking chain.

5 In another aspect, the present invention provides a method of handling a tubular comprising supporting the tubular along a first portion of an upset using a first support member and supporting the tubular along a second portion of the upset using a second support member. In one embodiment, the method further comprises remotely controlling at least one of the first support member and the second support member. In another aspect, the method includes providing a fluid to first support member during rotation of the
10 tubular.

In another embodiment, the method is used to connect the tubular to a second tubular. To connect the tubulars, the method may further comprise compensating for movement of the tubular during the connection. In another aspect, the method further comprises providing a rotary seal to provide communication between the first support
15 member and a controller. The method may also comprise aligning the tubular with the second tubular using a tubular guide member. The tubulars may be aligned by recalling a memorized position of a previously aligned tubular.

In another aspect, the tubulars are connected by rotating the tubular relative to the second tubular using a tong assembly. The tong for rotating the tubular may be translated
20 into position to connect the tubulars. The method also includes remotely operating the tong assembly.

In another aspect, the method includes absorbing a load experienced by the second support member. In one embodiment, the load is absorbed by the rotary table. The method also includes disposing the second support member on a rotary table. In another
25 embodiment, the method includes remotely opening or closing the rotary table.

In another aspect still, the method of handling the tubular includes ensuring at least one of the first support member or the second support member is retaining the tubular.

In another aspect, the present invention provides a joint compensation system for a wellbore tubular. The joint compensation system includes a joint compensator; an elevator for retaining the tubular, the elevator coupled to the joint compensator; and a rotary seal operatively coupled to the elevator to provide communication between the elevator and a controller. In one embodiment, communication between the elevator and the controller comprises sending a fluid signal or an electric signal. In another embodiment, the rotary seal maintains communication between the elevator and the controller during rotation of the elevator. In yet another embodiment, the elevator is a side door elevator. In yet another embodiment, the elevator comprises a fluid operated piston and cylinder assembly.

In another aspect, the present invention provides a load absorbing table for a tubular gripping member comprising a load absorbing member disposed on a flat support member. In one embodiment, the load absorbing member comprises a polyurethane layer. In another embodiment, the table is movable between an open position and a closed position. In yet another embodiment, the load absorbing member comprises one or more piston and cylinder assemblies. Preferably, the one or more piston and cylinder assemblies are fluid operated. In another embodiment, the table is flush mounted. In yet another embodiment, the table is remotely operable. In yet another embodiment, the table is adapted to compensate for rig movement, thereby maintaining the flat support member in a substantially horizontal position.

BRIEF DESCRIPTION OF THE DRAWINGS

So that the manner in which the above recited features of the present invention are attained and can be understood in detail, a more particular description of the invention, briefly summarized above, may be had by reference to the embodiments thereof which are illustrated in the appended drawings.

It is to be noted, however, that the appended drawings illustrate only typical embodiments of this invention and are therefore not to be considered limiting of its scope, for the invention may admit to other equally effective embodiments.

Figure 1 is a partial view of a rig having a tubular handling system according to aspects of the present invention.

Figure 2 is a view of a joint compensator system suspended from a traveling block.

Figure 3 is a partial cross-sectional view of a rotary seal suitable for use with the
5 joint compensator system of Figure 2.

Figure 4 is a cross-sectional view of a riser supported by an elevator according to aspects of the present invention.

Figure 5 is an isometric view of a riser supported by a tubular handling system according to aspects of the present invention.

10 Figure 6 is a cross-sectional view of a riser supported by a tubular handling system according to aspects of the present invention.

Figure 7 is a cross-sectional view of a riser supported by a spider according to aspects of the present invention.

15 Figure 8 shows a rotary table for supporting a spider according to aspects of the present invention.

Figure 9 is a partial view of the rotary table of Figure 8.

Figure 10 is another embodiment of a rotary table according to aspects of the present invention.

20 Figure 11 is another embodiment of a rotary table according to aspects of the present invention.

Figure 12 is a flow chart illustrating an exemplary interlock system according to aspects of the present invention.

Figure 13 is a top view of a tubular guide member shown in Figure 1.

Figure 14 is a cross-sectional view of the tubular guide member of Figure 13 along line A-A.

Figure 15 is a view of an embodiment of a tong assembly in operation with a tubular string positioned therein.

5 Figure 16 is a side view of the tong assembly showing a detail of gate locks on a power tong and a back up tong and a detail of a rotor lock on the power tong.

Figure 17 is a section view of the power tong illustrating a rotor with jaws according to aspects of the invention.

Figure 18 is a top view of the power tong.

10 Figure 19 is a side view of a motor disposed on a housing of the power tong that operates a pump on the rotor in order to actuate the jaws.

Figure 19A is a view of an end of the motor along line 19A-19A in Figure 19.

Figure 19B is a view of an end of the pump along line 19B-19B in Figure 19.

15 Figure 20 is a schematic of a back up tong hydraulic circuit used to actuate jaws of the back up tong.

Figure 21 is a schematic illustrating engagement of the motor and the pump used in a rotor hydraulic circuit that actuates the jaws of the power tong.

20 Figure 22 is a schematic of a portion of a tong assembly hydraulic circuit that provides a safety interlock between the rotor lock and fluid supplied to operate drive motors.

DETAILED DESCRIPTION OF THE PREFERRED EMBODIMENT

Aspects of the present invention provide a tubular handling system 100 for making up or breaking out tubulars. In one aspect, the tubular handling system 100 is adapted

retain a tubular without damaging the outer surface of the tubular body. In another aspect, at least part of the tubular handling process is remotely controllable.

For clarity purposes, the tubular handling system will be described with respect to the make up process. However, it is understood that the system may also be used to
5 break out tubulars. Additionally, although the make up process is described for a riser, the process is equally applicable to other types of wellbore tubulars such as casing, drill pipe, and tubing.

The tubular handling system includes a variety of apparatus for making or breaking the tubular connection. Figure 1 shows a rig equipped with the tubular handling system for
10 performing wellbore operations that involve picking up/laying down tubulars. Generally, the rig includes a traveling block suspended by cables above the rig floor. An elevator for retaining a riser section is disposed below the traveling block and is axially movable therewith. A joint compensator assembly may be disposed between the traveling block
15 and the traveling block to compensate for the axial movement of the riser section during make up of the threaded connection.

The riser string for connection with the riser section is held in the rig floor by a spider. In one embodiment, the elevator and the spider are adapted to retain the risers without applying a radial gripping force. The rig may also include a tong assembly for
20 rotating the riser section relative to the riser strings to complete the make up. A stabbing guide may also be used to align the riser section to facilitate the connection process.

A. Joint Compensator Assembly

Figure 2 shows an exemplary joint compensator assembly 200 according to aspects of the present invention. Other suitable joint compensators are disclosed in U.S. Patent No. 6,056,060, issued to *Abrahamsen et al.* and U.S. Patent No. 6,000,472, issued to
25 *Albright et al.*, which patents are assigned to the same assignee of the present application. In one embodiment, the joint compensator assembly 200 includes a pair of main bails 205, or links, suspended from the lift eyes 207 of the traveling block 210. The lower ends of the main bails 205 are coupled to the lift eyes 222 of an upper elevator 220. A cable 225

extends from the lower end of the traveling block 210 and connects to a shackle 232 of the joint compensator 230. The joint compensator 230 may be any suitable joint compensator known to a person of ordinary skill in the art. Examples of the joint compensator include air cylinder compensator, hydraulic compensator, and air spring compensator. A swivel 5 235 interconnects the joint compensator 230 to a lift member 240 or becket. The upper end of the lift member 240 extends through the upper elevator 220 and the lower end of the lift member 240 defines a hook end that is releasably connected to two support links 245, which are adapted to support the lower elevator 250. The outer diameter of the upper end of the lift member 240 above the upper elevator 220 is sufficiently sized such that it 10 will not pass through the upper elevator 220. In this respect, the upper elevator 220 may be lifted to contact the bottom portion of the upper end of the lift member 240, thereby transferring the load of the riser from the lift member 240 to the upper elevator 220.

In one aspect, the joint compensator assembly 200 includes a rotary seal 260 disposed between the upper elevator 220 and the hook end of the lift member 240. Any 15 suitable rotary seal known to a person of ordinary skill in the art may be used. Figure 3 shows an exemplary rotary seal 260 according to aspects of the present invention. The rotary seal 260 includes an inner tubular body 262 concentrically disposed within an outer tubular body 265. The outer body 265 is formed by connecting two outer body portions. Two flanges 266 are attached to the upper portion of the outer body 265 to allow the outer 20 body 265 to be connected to the upper elevator 220 using one or more links 268. Because it is connected to the upper elevator 220, the outer body 265 is non-rotational during make up. On the other hand, the inner body 262 is attached to the lift assembly 240, which causes the inner body 262 to rotate with the lower elevator 250 during make up.

25 The rotary seal 260 provides a method for communication with the lower elevator 250. For example, control lines may attach to ports 267 formed in the outer body 265 of the rotary seal 260. Each of the outer ports 267 is communicable with a mating port 268 in the inner body 262. Particularly, the ports 267, 268 are adapted to allow fluid communication between the outer body 265 and the inner body 262 even though the inner 30 body 262 is rotating relative to the outer body 265. Additional control lines are provided to

interconnect the mating ports 268 exiting the inner body 262 to the lower elevator 250. In this manner, the addition of the rotary seal 260 to the joint compensator assembly 200 allows signal transmission to and from the lower elevator 250.

Control lines attached to the lower elevator 250 may be used to operate the lower elevator 250. As shown, the lower elevator 250 is a side door elevator. The lower elevator 250 includes two side doors 251, 252 hingedly attached to the body of the elevator 250. A latch 253 is used to keep the side doors 251, 252 closed. The side doors 251, 252 and the latch 253 may be operated by one or more cylinder assemblies (not shown). The cylinder assemblies are controlled by signals transmitted through the control lines. The cylinder assemblies may be actuated using any suitable manner known, including electrics, mechanics, or fluids such as hydraulics and, preferably, pneumatics. Pneumatic fluid sent through the rotary seal 260 and the control lines may sequentially release the latch 253 and open the side doors 251, 252 to receive a riser section. Specifically, the cylinder assemblies pivot the side doors 251, 252 outward to enable the riser to pass between the side doors 251, 252. In this manner, the rotary seal 260 allows the lower elevator 250 to be remotely controlled or operated.

B. Elevator and Spider Assembly

In another aspect, the lower elevator is used in combination with a spider to handle a riser 10. As shown in Figure 4, the riser 10 includes a riser body 15 and an upset member 20. The upset member 20 contains the connector 25 for connection with another riser. As such, the upset member 20 has a larger outer diameter than the outer diameter of the riser body 15. It is understood that the upset member 20 may attach to the tubular body 15 or formed integral thereto.

In one embodiment, the elevator 50 and spider 70 combination is adapted to take advantage of the large upset member 20 of the riser 10 as illustrated in Figure 5. The elevator 50 defines two half portions 50A, 50B operatively hinged together and having a bore 55 therethrough. Suitable elevators include an elevator 50 hinged on one side and having a latch 58 on another side. Alternatively, an elevator 50 designed to open on two different sides, such as having a hinge on two sides, may be employed. Preferably, the

elevator 50 is a fluidly operated side door elevator 250 as shown in Figure 2. The elevator 50 includes two lift eyes 60 for attachment to a conveying member, such as a bail 245, whereby the elevator 50 may be axially translated.

Referring to Figure 4, the elevator 50 includes a support shoulder 62 to retain an elevator bushing 65. The elevator bushing 65 is partially disposed between the upset member 20 and the elevator 50 to center the upset member 20 in the elevator 50. The elevator bushing 65 also includes a riser support 67 adapted to engage a lower end 30 of the upset member 20. The riser support 67 is adapted to only contact an outer portion of the lower end 30 of the upset member 20. In this respect, elevator 50 engages the outer portion to support the weight of the riser 10, while leaving an inner portion of the lower end 30 of the upset member 20 unengaged. In this manner, the elevator 50 may support and axially translate the riser 10. Preferably, the end of the support shoulder 62 of the elevator 50 is beveled to facilitate the positioning of the spider 70 into contact with the inner portion of the upset member 20. It must be noted that aspects of the present invention are equally applicable to an elevator not equipped with the elevator bushing 65. For example, the support shoulder 62 of the elevator 50 may be adapted to directly engage the upset member 20, thereby supporting the riser 10 without the elevator bushing 65.

Referring to Figure 5, the spider 70 is adapted to engage the inner portion of the lower end 30 to support the weight of the riser 10. The spider 70 is located on the rig floor and defines two half portions 70A, 70B operatively coupled together and having a bore 75 therethrough, as illustrated in Figure 5. In one embodiment, a dual hinge connection 80 is disposed on opposite sides of the spider 70. The dual hinge connection 80 includes a plate 85 that couples the two portions 70A, 70B of the spider 70. A hinge pin 87 is used to movably connect each portion 70A, 70B to the plate 85, thereby allowing each portion 70A, 70B to pivot relative to the plate 85. The hinge pin 87 is removed to open the spider 70. Having a dual hinge connection 80 on each side allows the spider 70 to open on two different sides. It is understood that a single hinge connection may also be used, as well as a spider 70 that opens only from one side, without deviating from aspects of the present invention.

As shown in Figure 6, an upper portion 77 of the spider 70 has an outer diameter that is about the same or smaller than the outer diameter of the unengaged inner portion of the upset member 20. Additionally, the upper portion 77 of the spider 70 is size to fit between the riser support 67 of the elevator 50 and the riser body 15, thereby allowing the elevator 50 and the spider 70 to engage the upset member 20 at the same time.

In another embodiment, the spider 70 may employ a spider bushing 90 to center the riser 10 within the bore 75 of the spider 70, as illustrated in Figure 7. As shown, a portion of the spider bushing 90 is disposed between the riser 10 and the interior of the spider 70. The spider bushing 90 may have a ledge at one end to seat above the upper portion of the spider 70. The ledge of the spider bushing 90 has an outer diameter that is about the same or smaller than the outer diameter of the unengaged inner portion of the upset member 20. In this respect, the spider bushing 90 also allows the spider 70 and the elevator 50 to engage the riser 10 at the same time.

In operation, the elevator 50 is suspended by bails 245 above the spider 70 disposed on the rig floor. As shown in Figure 5, the riser 10 is supported by the elevator 50, and a portion of the riser body 15 is disposed through the bore 75 of the spider 70. Particularly, the elevator 50 is closed around the upset member 20 of the riser 10, and the elevator bushing 65 is employed to center the riser 10 in the elevator 50 as illustrated in Figure 4. In addition, the riser support 67 of the elevator bushing 65 is engaged with the outer portion of the lower end 30 of the upset member 20. In this position, the elevator 50 may be caused to axially translate the riser 10 relative to the spider 70.

Referring to Figure 6, the riser 10 is lowered toward the spider 70 until the inner portion of the upset member 20 engages the spider bushing 90. The beveled support shoulder 62 facilitates the insertion of the spider 70 if the spider 70 and the elevator 50 is slightly out of alignment. As illustrated, the elevator 50 and the spider 70 are adapted to allow the elevator 50 to partially encircle the spider 70, thereby allowing the elevator 50 and the spider 70 to engage the upset member 20 at the same time. In this position, either the elevator 50 or the spider 70 or both may support the riser 10 in the wellbore. Thereafter, the elevator 50 is opened to disengage from the riser 10, thereby transferring the load of the riser 10 entirely onto the spider 70.

The elevator 50 may now retrieve and position a second riser for connection with the riser 10 in the spider 70. After the risers have been connected, the elevator 50 may raise the risers relative to the spider 70 to transfer the load back to the elevator 50. Then the spider 70 is opened sufficiently to allow the riser 10 to be lowered into the wellbore. Once the upset member 20 has passed through the spider 70, the spider 70 is closed around the riser body of the second riser. Thereafter, the upset member of the second riser is lowered into engagement with the spider 70. This cycle of handling risers may be repeated to add additional risers. Because the elevator 50 and the spider 70 do not retain the riser 10 by gripping the riser body 15, the present invention provides methods and apparatus for handling risers without damaging the outer surface of the riser body.

C. Shock Table

In another aspect, the tubular handling system 100 provides a rotary table 300 to support the spider 370 on the rig floor. Preferably, the rotary table 300 is adapted to absorb the shock experienced by the spider 370. Figure 8 shows an exemplary rotary table 300 applicable to running risers. As shown, the spider 370 is attached to a support plate 310, which sits above a plurality of compensating cylinder assemblies 315. The cylinder assemblies 315 are disposed on a base 320 formed by two selectively connected base portions 321, 322. Figure 9 illustrates one of the base portions 321. The two base portions 321, 322 are selectively connected using a remotely controllable pin 325 inserted through the two base portions 321, 322. The cylinder assemblies 315 are adapted to compensate for shock and for any rig movement. In one embodiment, the cylinder assemblies 315 are interconnected and connected to an accumulator. The pressure in the accumulator is regulated with respect to the string weight to promote the optimal compensation. For example, as the rig moves or sways, each of the cylinders 315 may extend or retract to compensate for the rig movement, thereby keeping the support plate 310 horizontally leveled. To facilitate compensation, the upper end 316 of the cylinder assembly 315 is rounded and mates with an arcuate inner surface of a cap 317 disposed between the cylinder assembly 315 and the support plate 310. Relative pivotal movement is allowed by the arcuate inner surface when the respective cylinder 315 is compensating for shock or rig movement.

The base 320 is movably disposed on a shock table 330. Each side of the base 320 may include a base extension 335 that is connected to anchors 340 disposed at each end of the shock table 330. Preferably, a cylinder assembly 345 is used to connect the base extension 335 to the anchors 340. Actuation of the cylinder assemblies 345 moves
5 the respective base portions 321, 322 to and from the well center, thereby allowing the riser to move axially in the wellbore. The shock table 330 includes a hole that is sufficiently sized to accommodate axial movement of the riser without opening or closing. In this respect, the base portions 321, 322 move along the shock table 330 during operation. Attached below the shock table 330 is a cushion plate 350 and a shock
10 absorbing layer 355 disposed therebetween. In one embodiment, the shock absorbing layer 355 defines a polyurethane layer. The shock absorbing layer 355 provides additional shock absorbing capability to the shock table 330.

In another aspect, the shock table 330 may be flushed mounted. For example, the support plate 310 may be disposed directly on the shock table 330, and the compensating
15 cylinder assemblies 315 disposed below shock table 330. In this respect, the operating height of the spider 370 is reduced, thereby allowing easier access to the spider 370.

In another aspect, the spider 370 may sit directly on the polyurethane layer 355 and the cushion plate 350. Figure 10 shows a partial view of the simplified rotary table 300. The cushion plate 350 comprises two body portions secured together using a
20 remotely controllable pin, which is inserted through the pin holes 351 on each side of the rotary table 300. Each half of the spider 370 sits on a respective body portion of the rotary table 300. Support members 360 such as pins are disposed at each end of the cushion plate 350 to provide support to the spider 370 or extensions thereof. A tubular hole 358 is formed through the rotary table 300 to accommodate the riser. The rotary table 300 may
25 be closed to support the riser or opened to allow passage of the riser through the rotary table 300.

Figure 11 partially shows another embodiment of a flush mounted rotary table 300. In this embodiment, the compensating cylinder assemblies 315 are at least partially disposed within the wall 360 of the rotary table 300. The spider 370 may be disposed on a
30 support plate 365 that is operatively connected to the cylinder assemblies 315. The wall

360 of the rotary table 300 may be at least partially disposed in the rig floor to lower the operating height of the spider 370.

D. Interlock System

In another aspect, the tubular handling system 100 includes an interlock system to insure the riser is retained by at least the spider 370 or the elevator 250. A suitable interlock system is disclosed in U.S. Patent No. 7,073,596, which is assigned to the same assignee of the present invention. In one embodiment, the elevator 250 includes an elevator latch sensor 280 (Figure 8) located at the latch 253 to detect when the elevator 250 is opened or closed. Similarly, the spider 370 includes a spider piston sensor 380 (Figure 9) located at the remotely controllable pin 325 to detect when the spider 370 is opened or closed. Sensor data from the sensors 280, 380 are transmitted to a controller 390. Preferably, sensor data 512 from the elevator latch sensor 280 are transmitted to the controller 390 using the control lines connected to the rotary seal 260 of joint compensator assembly 200. In this respect, the rotary seal 260 advantageously allows the remote operation of the elevator 250. It must be noted that the sensors may be placed at any suitable location known to a person of ordinary skill in the art so long as they can detect the status of the elevator or spider. For example, a sensor may be placed at the cylinder assemblies responsible for opening and closing the elevator 250, or a sensor may be placed at the cylinders 345 for opening or closing the spider 370.

The controller 390 includes a programmable central processing unit that is operable with a memory, a mass storage device, an input control unit, and a display unit. Additionally, the controller 390 includes well-known support circuits such as power supplies, clocks, cache, input/output circuits and the like. The controller 390 is capable of receiving data from sensors and other devices and capable of controlling devices connected to it.

One of the functions of the controller 390 is to prevent the opening of the spider 370 and the lower elevator 250 at the same time. Preferably, the spider 370 is locked in the closed position by a solenoid valve that is placed in the control line for the source of fluid power operating the remotely controllable pin 325. Similarly, the elevator 250 is locked in

the closed position by another solenoid valve that controls the fluid source to the cylinder assemblies actuating the elevator latch 253. The solenoid valves are operated by the controller 390, which is programmed to keep the valves closed until certain conditions are met. Although electrically operated solenoid valves are preferred, the solenoid valves may be fluidly or pneumatically operated so long as they are controllable by the controller 390. Generally, the controller 390 is programmed to keep the spider 370 locked until the riser is successfully joined to the riser string and supported by the elevator 250.

Figure 12 is a flow chart illustrating an exemplary interlock system for use with the spider 370 and the elevator 250 to connect one or more risers. Initially, at step 500, the riser string is retained in the wellbore and prevented from axial movement by the spider 370. Sensor data 502 from the spider piston sensor 380 indicating that the spider 370 is closed is transmitted to the controller 390. At step 510, the elevator 250 is moved to engage a riser section to be connected with the riser string. When the elevator 250 is closed around the riser section, the sensor 280 sends a signal 512 to the controller 390.

At step 520, the riser section is moved to the well center for connection with the riser string. A tubular guide member is used to align riser section with the riser string. Next, at step, 530, a tong is moved into position to connect the riser section to the riser string. After the connection is completed, at step 540, the spider 370 disengages from the riser string. At step 550, the extended riser string is then lowered through the spider 370. Thereafter, at step 560, the spider 370 reengages the riser string. After engagement, at step 560, the spider piston sensor 380 transmits the sensor data 562 to the controller 390. After receiving the sensor data 562 indicating that the spider 370, the controller 390 allows the elevator 250 to disengage from the riser string and pick up another riser for connection with the riser string.

E. Tubular Guide Member

In another aspect, the tubular handling system 100 includes a tubular guide member 101 for guiding the riser section into alignment with the riser string, as shown in Figure 1. A suitable tubular guide member 101 is disclosed in U.S. Patent No. 7,140,445. Figures 13-14 depict an exemplary tubular guide member 101 according to aspects of the

present invention. Figure 13 presents a top view of the tubular guide member 101, while Figure 14 presents a cross-sectional view of the tubular guide member 101 along line A-A. The tubular guide member 101 includes a base 105 at one end for attachment to the rig. The gripping member 150 is disposed at another end, or distal end, of the tubular guide member 101. A rotor 110 is rotatably mounted on the base 105 and may be pivoted with respect to the base 105 by a piston and cylinder assembly 131. One end of the piston and cylinder assembly 131 is connected to the base 105, while the other end is attached to the rotor 110. In this manner, the rotor 110 may be pivoted relative to the base 105 on a plane substantially parallel to the rig floor upon actuation of the piston and cylinder assembly 131. In another embodiment, the tubular guide member 101 may be disposed on a rail such that it may move axially relative to the rig.

A conveying member 120 interconnects the gripping member 150 to the rotor 110. In one embodiment, two support members 106, 107 extend upwardly from the rotor 110 and movably support the conveying member 120 on the base 105. Preferably, the conveying member 120 is coupled to the support members 106, 107 through a pivot pin 109 that allows the conveying member 120 to pivot from a position substantially perpendicular to the rig floor to a position substantially parallel to the rig floor. Referring to Figure 14, the conveying member 120 is shown as a telescopic arm. A second piston and cylinder assembly 132 is employed to pivot the telescopic arm 120 between the two positions. The second piston and cylinder assembly 132 movably couples the telescopic arm 120 to the rotor 110 such that actuation of the piston and cylinder assembly 132 raises or lowers the telescopic arm 120 relative to the rotor 110. In the substantially perpendicular position, the tubular guide member 101 is in an unactuated position, while a substantially parallel position places the tubular guide member 101 in the actuated position.

The telescopic arm 120 includes a first portion 121 slidably disposed in a second portion 122. A third piston and cylinder assembly 133 is operatively coupled to the first and second portions 121, 122 to extend or retract the first portion 121 relative to the second portion 122. In this respect, the telescopic arm 120 and the rotor 110 allow the tubular guide member 101 to guide the riser into alignment with the riser in the spider 370

for connection therewith. Although a telescopic arm 120 is described herein, any suitable conveying member known to a person of ordinary skill in the art are equally applicable so long as it is capable of positioning the gripping member 150 at a desired position.

5 The gripping member 150, also known as the "head," is operatively connected to the distal end of the telescopic arm 120. The gripping member 150 defines a housing 151 movably coupled to two gripping arms 154, 155. Referring to Figure 13, a gripping arm 154, 155 is disposed on each side of the housing 151 in a manner defining an opening 152 for retaining a riser. Piston and cylinder assemblies 134, 135 may be employed to actuate the gripping arms 154, 155. One or more centering members 164, 165 may be disposed
10 on each gripping arm 154, 155 to facilitate centering of the riser and rotation thereof. An exemplary centering member 164, 165 is a roller, which may include passive rollers or active rollers having a driving mechanism.

It is understood that the piston and cylinder assemblies 131, 132, 133, 134, and 135 may include any suitable fluid operated piston and cylinder assembly known to a person of
15 ordinary skill in the art. Exemplary piston and cylinder assemblies include a hydraulically operated piston and cylinder assembly and a pneumatically operated piston and cylinder assembly.

In another aspect, the gripping member 150 may be equipped with a spinner 170 to rotate the riser retained by the gripping member 150. As shown in Figure 14, the spinner
20 170 is at least partially disposed housing 151. The spinner 170 includes one or more rotational members 171, 172 actuated by a motor 175. The torque generated by the motor 175 is transmitted to a gear assembly 178 to rotate the rotational members 171, 172. Because the rotational members 171, 172 are in frictional contact with the riser, the torque is transmitted to the riser, thereby causing rotation thereof. In one embodiment, two
25 rotational members 171, 172 are employed and equidistantly positioned relative to a central axis of the gripping member 150. An exemplary rotational member 171 includes a roller. Rotation of the riser will cause the partial make up of the connection between the risers. In another aspect, a rotation counting member 180 may optionally be used to detect roller slip. It is understood that the operation may be reversed to break out a
30 tubular connection.

A valve assembly 190 is mounted on the base 105 to regulate fluid flow to actuate the appropriate piston and cylinder assemblies 131, 132, 133, 134, 135 and motor 175. The valve assembly 190 may be controlled from a remote console (not shown) located on the rig floor. The remote console may include a joystick which is spring biased to a central, or neutral, position. Manipulation of the joystick causes the valve assembly 190 to direct the flow of fluid to the appropriate piston and cylinder assemblies. The tubular guide member 101 may be designed to remain in the last operating position when the joystick is released.

In another aspect, the tubular guide member 101 may include one or more sensors to detect the position of the gripping member 150. An exemplary tubular guide member having such a sensor is disclosed in U.S. Patent No. 7,073,598, assigned to the same assignee of the present invention. In one embodiment, a linear transducer may be employed to provide a signal indicative of the respective extension of piston and cylinder assemblies 131, 133. The linear transducer may be any suitable linear transducer known to a person of ordinary skill in the art, for example, a linear transducer sold by Rota Engineering Limited of Bury, Manchester, England. The detected positions may be stored and recalled to facilitate the movement of the riser. Particularly, after the gripping member 150 has placed the riser into alignment, the position of the gripping member 150 may be determined and stored. Thereafter, the stored position may be recalled to facilitate the placement of additional risers into alignment with the riser string.

F. Tong

In another aspect, a tong may be remotely operated to connect the risers. An exemplary tong is disclosed in U.S. Patent No. 7,281,451, which is assigned to the same assignee as the present invention.

Figure 15 illustrates an embodiment of a tong assembly 1100 suitable for connecting the risers. The tong assembly 1100 includes a power tong 1101 disposed above a back up tong 1102. In operation, the tong assembly 1100 suspends from a handling tool 1104 that positions the tong assembly 1100 around a tubular of a tubular string such as a lower tubular 1108 held by a spider 1106 and a stand or upper tubular

1110. As described in more detail below, the power tong 1101 grips the upper tubular 1110 and the back up tong 1102 grips the lower tubular 1108. Three drive motors 1111 operate to provide torque to the power tong 1101 to rotate the upper tubular 1110. In one embodiment, the tong assembly may apply 1300,000 foot pounds of torque to a riser
5 thread connection in a riser string that is about twenty inches in diameter.

Each of the tongs 1101, 1102 are segmented into three segments such that the front two segments pivotally attach to the back segment and enable movement of the tongs 1101, 1102 between an open and a closed position. In the open position, the front sections pivot outward enabling the tubulars 1108, 1110 to pass between the front
10 sections so that the handling tool 1104 can align the tubulars 1108, 1110 within the tongs 1101, 1102. The tongs 1101, 1102 move to the closed position as shown in Figure 15 prior to make up or break out operations. Pistons 181128 (only one piston is visible) on each side of the power tong 1101 operate to pivot the front segments relative to the back segment in order to open and close a gate between the front segments that is formed
15 where an extension 1132 on one of the front segments mates with a corresponding grooved portion 1134 of the other front section. Similarly, pistons 1130 (again only one piston is visible) on each side of the back up tong 1102 operate to pivot the front segments relative to the back segment in order move the back up tong between the open and closed position. The pistons 181128, 1130 may be operated by a tong assembly hydraulic circuit
20 that supplies fluid pressure to various components of the tong assembly 1100 through a common pressure source. As with all other components of the tong assembly 1100 operated by the tong assembly hydraulic circuit, automated or manually operated valves (not shown) may be used to separately or in combination open and close fluid supply to each component (e.g. the pistons 181128, 1130) at the desired time.

25 A torque bar assembly 1112 located adjacent a counterweight 1120 connects the power tong 1101 to the back up tong 1102. The torque bar assembly 1112 includes two arms 1114 extending downward from each end of a horizontal top bar or suspension 1116. A back end of the power tong 1101 connects to a horizontal shaft 1118 that extends between the arms 1114 below the suspension 1116. The shaft 1118 may fit within
30 bearings (not shown) in the arms 1114 to permit pivoting of the power tong 1101 relative to

the torque bar assembly 1112. Damping cylinders 1400 (shown in Figure 18) connect between a top of the power tong 1101 and the suspension 1116 to prevent free swinging of the power tong 1101 about the shaft 1118. Clamps 1122 on the back up tong 1102 grip a longitudinal recess 1124 in the arms 1114, thereby securing the back up tong 1102 to
5 the torque bar assembly 1112. The clamps 1122 slide along the recess 1124 to permit movement of the back up tong 1102 relative to the power tong 1101 during make up or break out operations. The torque bar assembly 1112 provides a connection between the tongs 1101, 1102 that permits the back up tong 1102 to rise into near contact with the power tong 1101.

10 The torque bar assembly 1112 keeps side forces out of the connection between the tubulars 1108, 1110 by eliminating or at least substantially eliminating shear and bending forces. As the power tong 1101 applies torque to the upper tubular 1110, reaction forces transfer to the torque bar assembly 1112 in the form of a pair of opposing forces transmitted to each arm 1114. The forces on the arms 1114 place the suspension 1116 in
15 torsion while keeping side forces out of the connection. A load cell and compression link 1126 may be positioned between the clamp 1122 and back up tong 1102 in order to measure the torque between the power tong 1101 and back up tong 1102 during make up and break out operations.

Figure 16 shows a side of the tong assembly 1100 and a detail of a power tong gate
20 lock 1200, a back up gate lock 1201 and a rotor lock 1202. The gate locks 1200, 1201 lock the tongs 1101, 1102 in the closed position. The rotor lock 1202 prevents rotation of a rotor 1300 when in the open position and prevents any possible misalignment of parts of the rotor 1300 caused by moving the power tong 1101 to the open position since the rotor may be forced outward in the open position. Thus, the rotor lock 1202 maintains the rotor
25 1300 in position and prevents rotation of the rotor 1300 until the rotor lock 1202 is actuated.

The power tong gate lock 1200 includes an outer shroud 1204 mounted on a housing 1207 of the power tong 1101. The outer shroud 1204 supports a gear profiled bolt 1206 having a lifting member 1208 connected thereto. Rotation of a gear 1216 mated with
30 the gear profiled bolt 1206 lowers and raises the gear profiled bolt 1206 between a power

tong gate locked position and a power tong gate unlocked position. In the power tong gate locked position shown in Figure 16, the gear profiled bolt 1206 inserts downward into an aperture within the extension 1132 and an aperture in the corresponding grooved portion 1134 that form the gate in the housing 1207 of the power tong 1101. Thus, the gear profiled bolt 1206 maintains the power tong 1101 in the closed position by preventing movement between the extension 1132 and the corresponding grooved portion 1134 when in the power tong gate locked position. The gear may be actuated by a hydraulic or electric motor (not shown) controlled by the tong assembly hydraulic circuit.

At the end of the lifting member 1208, a slotted lip 1210 receives a recessed profile 1212 at the top of a rotor bolt 1214. Due to the slotted lip 1210 fitting in the recessed profile 1212, the lifting member 1208 which raises and lowers with the gear profiled bolt 1206 acts to raise and lower the rotor bolt 1214 when the rotor bolt 1214 is aligned below the lifting member 1208. Similar to the housing of the power tong 1101, a rotor 1300 is gated so that the rotor 1300 opens and closes as the power tong 1101 moves between the open and closed positions. Thus, the rotor 1300 includes a rotor extension 1232 and a corresponding rotor grooved portion 1234 that each have an aperture therein for receiving the rotor bolt 1214 which prevents movement between the rotor extension 1232 and the corresponding rotor grooved portion 1234 while in the power tong gate locked position. As the rotor 1300 rotates during make up and break out operations, the recessed profile 1212 of the rotor bolt 1214 slides out of engagement with the slotted lip 1210 and may pass through the slotted lip 1210 with each revolution of the rotor 1300. The rotor bolt 1214 realigns with the lifting member 1208 when the rotor returns to a start position such that the rotor bolt 1214 may be raised to the power tong gate unlocked position. Only when the rotor 1300 is in the start position with segments of the rotor 1300 properly aligned may the power tong 1101 be moved to the open position. Figure 17 further illustrates the power tong 1101 in the start position with the rotor bolt 1214 and the gear profiled bolt 1206 maintaining the power tong 1101 in the closed position.

The back up gate lock 1201 locks the gate on the back up tong 1102 in the closed position similar to the power tong gate lock 1200 for the power tong 1101. A single back up bolt 1218 operated by a gear 1220 moves between a back up gate locked position and

a back up gate unlocked position. Since the back up tong 1102 does not have a front housing or a rotor that rotates, a back up jaw assembly may include a gated section therein with mating features such as the gate of the power tong 1101. Thus, the bolt 1218 in the back up gate locked position prevents movement between members in the gated
5 section of the back up jaw assembly similar to the gear profiled bolt 1206 and rotor bolt 1214 used in the power tong gate lock 1200 on the power tong 1101.

Referring still to Figure 16, the rotor lock 1202 mounts to the housing 1207 of the power tong 1101 and includes a body 1222, a female end 1224, a piston 1225 and a spring 1228. The rotor lock 1202 moves between a rotor locked position and a rotor
10 unlocked position. The rotor lock 1202 normally biases to the rotor locked position and must be actuated by fluid pressure from the tong assembly hydraulic circuit to the rotor unlocked position. In the rotor locked position shown, the female end 1224 coupled to the piston 1225 receives a male member 1226 protruding from the rotor 1300. The male member 1226 aligns below the female end 1224 when the rotor 1300 is in the start
15 position. The engagement between the female end 1224 and the male member 1226 prevents rotation and movement of the portion of the rotor having the male member 1226 thereon. As shown in the top view of the power tong 1101 in Figure 18, the power tong 1101 may include two rotor locks 1202 on each side which may be aligned with pivot points 1304 (shown in Figure 17) where the front segments of both the housing 1207 and
20 rotor 1300 open. Thus, the rotor locks 1202 may engage both front opening segments of the rotor 1300 to secure the segments relative to the housing 1207 of the power tong 1101 when the power tong 1101 is in the open position. Prior to make up or break out operations, the female end 1224 retracts to the rotor unlocked position by fluid pressure applied to the piston 1225 in order to urge the piston 1225 upward against the bias of the
25 spring 1228. Thus, the rotor lock 1202 permits rotation of the rotor 1300 only when in the rotor unlocked position since the female end 1224 and male member 1226 disengage.

Figure 17 illustrates the rotor 1300 within the power tong 1101. The rotor 1300 includes a segmented rotary gear 1302, three active jaws 1306, and support members 1308 disposed between the jaws 1306. The support members 1308 are fixed within the
30 inner diameter of the rotary gear 1302 such that the jaws 1306 and the support members

1308 rotate with the rotary gear 1302. Prior to rotating the rotor 1300, the jaws 1306 move inward in a radial direction from a release position shown to a gripping position with the jaws 1306 in gripping contact with the tubular 1110. A spring (not shown) biases the jaws 1306 to the release position. Each of the jaws 1306 include two pistons 1312 hydraulically operated by a separate rotor hydraulic circuit to push a jaw pad 1314 against the tubular 1110 in the gripping position. Three pinions 1310 driven by the three motors 1111 (shown in Figure 15) mesh with an outer circumference of the rotary gear 1302 in order to rotate the rotor 1300 during make up and break out operations. Since the pivot points 1304 for both the housing 1207 and rotor 1300 are the same, there is no relative movement between the rotor 1300 and housing 1207 as the power tong 1101 moves between the open and closed positions. Consequently, the two motors 1111 on the front segments of the housing 1207 do not move relative to the rotary gear 1302 such that it is not necessary to actuate the two motors 1111 as the power tong 1101 opens and closes.

The rotary gear 1302 may be tensioned prior to assembly such that the rotary gear 1302 is initially deformed. Thus, when the rotary gear 1302 is assembled in the power tong 1101 and when the tubular 1110 is gripped by the jaws 1306, the deformed rotary gear reworks to obtain a circular outer circumference.

Support rollers 1316 hold the rotary gear 1302 in order to axially position the rotor 1300 within the power tong 1101. Each of the pinions 1310 creates a force on the rotary gear 1302 that is perpendicular to the tangential. Due to the 120° spacing of the pinions 1310, these forces are all directed to the center of the rotor 1300 and cancel one another, thereby centrally aligning the rotor 1300. Therefore, the rotor 1300 does not require radial guiding since the rotary gear 1302 centrally aligns itself when a load is placed on the pinions 1310 arranged at 120° around the rotary gear 1302.

The jaws 1306 and support members 1308 laterally support one another throughout a 360° closed circle such that corresponding torque from the rotor 1300 only transmits to the tubular 1110 in a tangential direction without resulting in any tilting of the jaws 1306. During make up and break out operations, a side face of one jaw 1306 having a close contact with a side face of an adjacent support member 1308 transmits force to the adjacent support member 1308 which is in close contact with another jaw 1306. The

closed 360° arrangement effectively locks the jaws 1306 and support members 1308 in place and helps the jaws 1306 and support members 1308 to laterally support one another, thereby inhibiting tilting of the jaws 1306. Thus, load on the tubular 1110 equally distributes at contact points on either side of the jaw pads 1314. Adapters (not shown) for
5 both the support members 1308 and jaws 1306 may be added in order to allow the power tong 1101 the ability to grip tubulars having different diameters.

The jaw assembly (not shown) in the back up tong 1102 may be identical to the rotor 1300. However, the jaw assembly in the back up tong 1102 does not rotate such that an outer ring surrounding jaws in the back up tong may not be geared with motors
10 providing rotation.

The top view of the power tong 1101 in Figure 18 shows a motor 1402 used to operate a pump 1404 that supplies hydraulic pressure to the rotor hydraulic circuit that actuates the jaws 1306. The motor 1402 may be actuated by the tong assembly hydraulic circuit. The motor 1402 mounts on the housing 1207 while the pump mounts on the rotor
15 1300. Therefore, the motor 1402 must disengage from the pump 1404 after the pump 1404 actuates the jaws 1306 in order to allow the pump 1404 to rotate with the rotor 1300 during make up and break out operations.

Figures 19, 19A and 19B illustrate a releasable coupling arrangement between the motor 1402 secured to the housing 1207 and the pump 1404 secured to the rotor 1300.
20 The motor 1402 slides along a guide shaft 1500 between an engaged position toward the pump 1404 and a disengaged position away from the pump 1404. As shown, a spring 1502 biases the motor 1402 to the disengaged position. Hydraulic fluid supplied from the tong assembly hydraulic circuit moves the motor 1402 against the bias of the spring 1502 toward the pump 1404. As the motor 1402 moves toward the pump 1404, a coupling such
25 as a claw 1504 of the motor 1402 engages a mating coupling such as an elongated S-shaped bar 1506 of the pump 1404. The claw 1504 and the S-shaped bar 1506 provide a wide angle for possible engagement with each other. However, the claw 1504 and S-shaped bar 1506 may interferingly hit one another without engaging. To simplify the next engagement of the claw 1504 with the S-shaped bar 1506 due to a missed engagement or
30 for subsequent operations of the pump 1404, the motor 1402 rotates the claw 1504 a small

amount as the motor 1402 slides on the guide shaft 1500 back to the disengaged position. As shown in further detail in Figure 21, pressurized fluid used to fill a piston chamber in order to move the motor 1402 on the guide shaft 1500 toward the pump 1404 flows to the motor 1402 to turn the claw 1504. Since the volume of the piston chamber remains the same, the claw 1504 of the motor 1402 rotates a fixed amount with every movement of the
5 motor 1402 between the engaged and disengaged positions.

Figure 20 illustrates a schematic of a back up tong hydraulic circuit 1600 used to actuate jaws 1602 of the back up tong 1102 in order to grip the lower tubular 1108 as shown in Figure 15. A grip line 1601 from the tong assembly hydraulic circuit selectively
10 supplies fluid pressure to a back up tong motor 1603 that operates a single back up tong pump 1604. The jaws 1602 of the back up tong 1102 connect to the back up tong pump 1604 which supplies an equal volume and pressure of fluid to each of the jaws 1602 through three equal flow outlets 1606. To prevent a stop of the motor/pump 1603, 1604 with only one of the jaws 1602 in gripping contact, the hydraulic circuit 1600 provides a
15 cascade circuit with flow from all three jaws 1602 passing to a single common adjustable pressure limiter 1608, a single common preset safety valve 1610 and a single common release check valve 1612. Due to the arrangement of the two check valves 1614, the pump 1604 continues to supply pressurized fluid even if one of the jaws 1602 grips prior to the other jaws 1602. Pressurized fluid supplied to the jaw gripping prematurely flows to
20 the tank 1616 while the other jaws continue to receive fluid pressure for proper actuation. Therefore, there is no volumetric influence of one of the jaws 1602 with respect to the other jaws. After completing the make up or break out operation, a hydraulic signal through a release line 1618 of the tong assembly hydraulic circuit opens the release check valve 1612 and permits fluid pressure acting on the jaws 1602 to dump to the tank 1616.
25 The back up tong hydraulic circuit 1600 with the pump 1604 may supply high pressures such as greater than 6000 pounds per square inch or 1500 bar.

Figure 21 shows a schematic illustrating engagement of the motor 1402 and the pump 1404 used in a rotor hydraulic circuit 1700 that actuates the jaws 1306 of the power tong 1101. The jaws 1306 actuate through a similar manner as described above with
30 respect to the back up tong hydraulic circuit 1600 in Figure 20. However, a release valve

1702 is opened upon completing the make up or break out operation. The schematic in Figure 21 also illustrates the motor 1402 that is moveable between the engaged and disengaged positions. To move the motor 1402 from the disengaged position to the engaged position, fluid selectively supplied from the tong assembly hydraulic circuit to an engage pump line 1704 passes through check valve 1708 and enters piston chamber 1710 in order to move the motor 1402 toward the pump 1404. The fluid pressure in the engage pump line 1704 closes check valve 1706. However, release of fluid pressure from the engage pump line 1704 permits pressurized fluid from the piston chamber 1710 to pass through check valve 1706 into a motor drive line 1712 in order to rotate a claw 1504 of the motor 1402 as described above when the motor returns from the engaged position to the disengaged position.

Figure 22 illustrates an interlock portion 1800 of the tong assembly hydraulic circuit that provides a safety interlock that includes the rotor locks 1202 and a motor lockout that selectively blocks fluid supplied to operate the drive motors 1111. The interlock portion 1800 includes a normally open pilot valve 1802 having an input from a dump line 1803 and an output to a tank 1816, a first check valve 1804 having an input from a break out supply line 1805 and an output to a reverse drive line 1810, and a second check valve 1806 having an input from a make up supply line 1807 and an output to a forward drive line 1812. An automated or manually operated drive valve 1818 selectively supplies fluid pressure to one of the supply lines 1805, 1807 at the appropriate time. Fluid supplied through the reverse drive line 1810 operates the motors 1111 for break out, and fluid supplied through the forward drive line 1812 operates the motors 1111 in an opposite direction for make up. Thus, the drive motors 1111 only operate when the check valves 1804, 1806 can open to permit fluid flow between one of the supply lines 1805, 1807 and a corresponding one of the drive lines 1810, 1812. A first pilot port line 1809 connects a pilot port of the first check valve 1804 with the break out line 1805, and a second pilot port line 1811 connects a pilot port of the second check valve 1806 with the make up line 1807. The check valves 1804, 1806 only open when the pilot port lines 1809, 1811 supply fluid pressure to the pilot ports. However, the pilot port lines 1809, 1811 do not supply an opening pressure to the pilot ports of the check valves 1804, 1806 when the pilot valve

1802 is open since the pilot port lines 1809, 1811 connect through check valve 1813 to the dump line 1803 that passes fluid to the tank 1816 when the pilot valve 1802 is open.

As described above, the rotor locks 1202 physically block rotation of the rotor 1300 until a fluid pressure is applied to the rotor locks 1202 in order to place the rotor locks 1202 in the rotor unlocked position. Thus, the fluid pressure for placing the rotor locks 1202 in the rotor unlocked position is supplied from the tong assembly hydraulic circuit through a disengage locks line 1808 that may be controlled independently from the supply lines 1805, 1807 by a lock valve 1820. A portion of the fluid from the disengage locks line 1808 is supplied to a pilot port of the pilot valve 1802 in order to close the pilot valve 1802 only when both the rotor locks 1202 are in the rotor unlocked position. Once the pilot valve 1802 closes, fluid pressure from either of the supply lines 1805, 1807 can pressurize a corresponding one of the pilot port lines 1809, 1811 that are no longer open to the tank 1816, thereby permitting opening of a corresponding one of the check valves 1804, 1806. Thus, opening the drive valve 1818 supplies fluid selectively to one of the supply lines 1805, 1807, which are blocked from operating the drive motors 1111 until actuation of the rotor locks 1202 unlocks the interlock that provides the motor lockout. Once both the rotor locks 1202 actuate and the drive valve 1818 is opened to permit fluid flow to the appropriate supply line 1805, 1807, a pressurized fluid is simultaneously supplied to all of the motors 1111 through a corresponding one of the drive lines 1810, 1812 during make up or break out. Further, each motor 1111 produces the same torque and any mechanical parts for "locking" such torque are not necessary as all the motors 1111 simultaneously stop hydraulically due to the check valves 1804, 1806. A gear change 1814 may be used to adjust the suction volume of the motors 1111 in order to adjust the speed of the motors 1111. Additionally, a solenoid valve (not shown) can be activated such that the drive motors 1111 are also immediately stopped, and a pressure limiter 1822 may protect the interlock portion 1800.

In alternative embodiments, the pilot valve 1802 is closed by a signal other than the hydraulic signal from the disengage locks line 1808. For example, the pilot valve 1802 may be controlled to close by an electric signal supplied thereto or may be manually closed. Further, the hydraulic circuit shown for the interlock portion 1800 may be used in

applications and methods other than tong assembly 1100 where there is a desire to block actuation of motors prior to receiving a signal from an interlock.

The tong assembly 1100 described herein may be used in a method of making up a tubular connection between a first tubular 1110 and a second tubular 1108. For clarity, the method is described using the reference characters of the figures described herein when possible. The method includes opening a power tong 1101 and back up tong 1102 of the tong assembly 1100 and positioning the tubulars 1108, 1110 therein. The method further includes, closing the tongs 1101, 1102 around the tubulars 1108, 1110, locking gate locks 1200, 1201 to maintain the tongs 1101, 1102 and a rotor 1300 in the closed position, actuating jaws 1306 of the tongs 1101, 1102 such that the power tong 1101 grips the first tubular 1110 and the back up tong 1102 grips the second tubular 1108, unlocking a rotor lock 1202 to permit rotation of the rotor 1300, and unlocking an interlock including a rotor motor lockout. Additional, the method includes rotating the rotor 1300 by distributing a drive force on the rotor 1300 such as by simultaneous rotation of at least three motors 1111, wherein rotating the rotor 1300 rotates the first tubular 1110 relative to the second tubular 1108 and forms the connection. The method may be used with connections in tubulars having diameters greater than fifteen inches such as risers.

In another aspect, the tong assembly may be suspended from a tong positioning device capable of translating the tong assembly toward the risers to thread the connection. An exemplary tong assembly is disclosed in U.S. Patent No. 6,412,553 assigned to the same assignee as the present application. In one embodiment, the positioning device comprises a single extendable beam having a variable length. A mounting assembly is coupled to one end of the beam for attachment to the rig, and the tong is suspended from the free end of the beam. The positioning device includes a motive assembly such as a piston and cylinder assembly adapted to extend or retract the beam. Extending or retracting the beam moves the tong to and away from the risers. The piston and cylinder assemblies may be operated by hydraulics, pneumatics, electrics, mechanics, and combinations thereof. In the preferred embodiment, the piston and cylinder assembly is adapted for remote controlled operation as is known to a person of ordinary skill in the art.

For example, the power source of the piston and cylinder assemblies may be controlled remotely.

In another aspect, the tong may be placed on a movable frame to transport the tong to and from the well center. Examples of such movable frames are disclosed in U.S. Patent No. 7,028,585, and U.S. Publication No. 2004/0035573. In one embodiment, actuation of the movable frame is remotely controlled.

Another suitable positioning device comprises a flexible chain provided with compression members and a flexible locking chain. The chains are brought into operative engagement to form a rigid member when a hydraulic motor is rotated counter-clockwise. The proximal end of the device is attached to the rig, while the distal end is suspended by a cable connected to the rig. A tong suspended from the distal end of the device may be advanced or withdrawn towards the riser by rotating the motor counter-clockwise or clockwise to extend or dismantle the rigid member. In the preferred embodiment, the hydraulic motor is adapted for remote controlled operation as is known to a person of ordinary skill in the art. Examples of such tong positioning devices are disclosed in U.S. Patent Nos. 6,322,472; 5,667,026; and 5,368,113, which patents are assigned to the same assignee of the present invention.

Referring back to Figure 12, the operation of the tubular handling system will now be discussed in more detail. Initially, at step 500, the riser string is retained in the wellbore and prevented from axial movement by the spider 370. Sensor data 502 from the spider piston sensor 380 indicating that the spider 370 is closed is transmitted to the controller 390. At step 510, the elevator 250 is moved to engage a riser section to be connected with the riser string. When the elevator 250 is closed around the riser section, the sensor 280 sends a signal 512 to the controller 390. The traveling block is then raised to lift the riser section. At this point the weight of the riser section is supported by the joint compensator.

At step 520, the riser section is moved to the well center for connection with the riser string. A tubular guide member 101 is used to align riser section with the riser string. Specifically, the gripping member 120 is extended toward the riser section and closed

around the riser section. Preferably, movement of the gripping member 120 is remotely controlled and performed by recalling a previous position of the gripping member 120. The tubular guide member 101 positions the riser section in alignment with the riser string for connection therewith.

5 Next, at step, 530, a tong assembly 1100 is moved into position to connect the riser section to the riser string. In one embodiment, a single extendable beam type tong positioning device is actuated to translate the tong toward the risers. The piston and cylinder assembly of the beam is remotely controlled to move the tong. Once in position, the backup tong is actuated to engage the riser string and the power tong is actuated to
10 engage the riser section. Thereafter, torque is supplied to the power tong to rotate the riser section relative to the riser string to make up the connection. As the threads are advanced, the joint compensator compensates for the axial movement of the riser section toward the riser string. Also, the rotary seal allows the lower elevator 250 to maintain communication with the remote controller during rotation of the riser section.

15 After the connection is completed, at step 540, the spider 370 disengages from the riser string. The lower elevator 250 is raised to transfer the weight of the extended riser string to the upper elevator 220. Thereafter, the spider is opened to allow passage of the riser string. In one embodiment, the shock table 300 is opened by first releasing the remotely controllable pin 325, and then actuating the cylinder assembly 345 to pull apart
20 the two base portions 321, 322. At step 550, the extended riser string is then lowered through the spider 370. Thereafter, at step 560, the spider 370 reengages the riser string. After engagement, at step 560, the spider piston sensor 380 transmits the sensor data 562 to the controller 390. After receiving the sensor data 562 indicating that the spider 370, the controller 390 allows the elevator 250 to disengage from the riser string and pick up
25 another riser for connection with the riser string. In this manner, the tubular handling assembly may be used to extend the riser string to the desired length. Although only some of the steps in the process is described as being remotely controlled, it must be noted that manipulation of the components of the tubular handling assembly throughout the entire process may be controlled remotely or automated. For example, all of the piston
30 and cylinder assemblies in each of the components may be adapted for remote control

capability. Moreover, the controls may be position in the same small area for easy access to the operator.

In another aspect, a fill up tool may be used with the tubular handling system. In one embodiment, two joint compensators are used to compensate for the thread action. Specifically, the upper end of one of the joint compensators is attached to one side of the upper elevator, and the lower end is coupled to a swivel via a cable. Additionally, cables extending below the swivel connect the lower elevator to the swivel. Before a tubular section is connected to the tubular string retained by the spider, the weight of the tubular section retained by the lower elevator is supported by the joint compensators. After the tubulars are connected, the upper elevator is lowered toward the rig floor to retain the tubulars, thereby supporting the weight of the connected tubulars. In one embodiment, the lower elevator may be a single joint elevator and the upper elevator may be a side door elevator.

A suitable fill up tool is disclosed in U.S. Patent No. 6,460,620, which is assigned to the same assignee of the present invention. In one embodiment, the fill up tool is a mudsaver valve having an elongated tubular main body supporting a tubular mandrel-like mudsaver closure member therein for movement between valve open and closed positions. A coil spring is disposed in the main body member and is engageable with the mudsaver closure member to bias the mudsaver closure member in a valve closed position. The mudsaver closure member includes an axial passage formed therein and ports opening from the axial passage to the exterior of the mudsaver closure member. The mudsaver closure member is engageable with an annular resilient packoff element and is pressure biased to move to an open position wherein the ports pass through the annular packoff element to allow fluid to flow through the valve. A flowback valve is integrated with the mudsaver valve and comprises an annular resistant duckbill type closure member mounted in a second body member attached to the main body member and responsive to pressure fluid in a casing in which the mudsaver valve is disposed to equalize fluid pressure between the interior of the casing or similar conduit and a supply conduit connected to the mudsaver valve.

While the foregoing is directed to the preferred embodiment of the present invention, other and further embodiments of the invention may be devised without departing from the basic scope thereof, and the scope thereof is determined by the claims that follow.

We claim:

1. A tubular handling system, comprising:
 - a first support member adapted to support a tubular utilizing a first portion of a shoulder of the tubular;
 - a second support member adapted to support the tubular utilizing a second portion of the shoulder; and
 - a rotary seal adapted to provide communication between the first support member and a controller while allowing rotation of the first support member.
2. The tubular handling system of claim 1, wherein at least one of the first support member and the second support member is remotely controllable.
3. The tubular handling system of claim 1, further comprising a joint compensator.
4. The tubular handling system of claim 1, wherein the first support member comprises a fluid operated side door elevator.
5. The tubular handling system of claim 4, wherein the side door elevator further comprises a sensor for determining whether the elevator is opened or closed.
6. The tubular handling system of claim 1, further comprising a rotary table for supporting the second support member.
7. The tubular handling system of claim 6, wherein the rotary table is adapted to absorb a force experienced by the second support member.
8. The tubular handling system of claim 7, wherein the rotary table comprises a polyurethane layer.
9. The tubular handling system of claim 7, wherein the rotary table comprises one or more piston and cylinder assemblies.

10. The tubular handling system of claim 9, wherein the rotary table is remotely controllable between an open position and a closed position.
11. The tubular handling system of claim 1, further comprising an interlock system for ensuring the tubular is retained by at least one of the first support member and the second support member.
12. The tubular handling system of claim 1, further comprising a tubular guide member for positioning the tubular.
13. The handling apparatus of claim 1, wherein the first and second support members support the tubular at the same time.
14. The tubular handling system of claim 1, further comprising a tong assembly for connecting the tubular with a second tubular.
15. The tubular handling system of claim 14, further comprising tong positioning device.
16. The tubular handling system of claim 15, wherein the tong positioning device comprises a single extendable beam having variable length.
17. A method of handling a tubular, comprising:
 - providing a rotary seal to provide communication between a first support member and a controller;
 - supporting the tubular along a first downward facing portion of an upset using a first support member;
 - supporting the tubular along a second downward facing portion of the upset using a second support member; and
 - remotely controlling at least one of the first support member and the second support member.
18. The method of claim 17, further comprising compensating for movement of the tubular during connection of the tubular with a second tubular.

19. The method of claim 18, further comprising translating a tong into position to connect the tubulars.
20. The method of claim 19, further comprising remotely operating the tong assembly.
21. The method of claim 17, further comprising providing a fluid to the first support member during rotation of the tubular.
22. The method of claim 17, further comprising absorbing a load experienced by the second support member.
23. The method of claim 22, wherein the load is absorbed by a rotary table.
24. The method of claim 23, further comprising remotely opening or closing the rotary table.
25. The method of claim 17, further comprising ensuring at least one of the first support member or the second support member is retaining the tubular.
26. The system of claim 1, wherein the rotary seal comprises a rotatable portion at least partially disposed in a non-rotatable portion.
27. The system of claim 26, wherein the rotatable portion is in fluid communication with the non-rotatable portion.
28. The system of claim 26, wherein the rotatable portion maintains fluid communication with the non-rotatable portion during rotation of the rotatable portion.
29. The tubular handling system of claim 1, wherein the communication between the first support member and the controller comprises transmitting a fluid signal or an electric signal.

30. The tubular handling system of claim 1, wherein the rotary seal maintains communication between the first support member and the controller during rotation of the first support member.

31. The tubular handling system of claim 3, wherein the communication between the first support member and the controller comprises transmitting a fluid signal or an electric signal.

32. The tubular handling system of claim 3, wherein the rotary seal maintains communication between the first support member and the controller during rotation of the first support member.

33. A tubular handling system, comprising:

a first support member adapted to support a tubular utilizing a first portion of an upset of the tubular;

a second support member adapted to support the tubular utilizing a second portion of the upset;

a rotary seal adapted to provide communication between the first support member and a controller while allowing rotation of the first support member; and

a rotary table for supporting the second support member.

34. The tubular handling system of claim 33, wherein the rotary table is adapted to absorb a force experienced by the second support member.

35. The tubular handling system of claim 34, wherein the rotary table comprises a polyurethane layer.

36. The tubular handling system of claim 34, wherein the rotary table comprises one or more piston and cylinder assemblies.

37. The tubular handling system of claim 36, wherein the rotary table is remotely controllable between an open position and a closed position.

38. A tubular handling system, comprising:

a first support member adapted to support a tubular utilizing a first portion of an upset of the tubular;

a second support member adapted to support the tubular utilizing a second portion of the upset;

a rotary seal adapted to provide communication between the first support member and a controller while allowing rotation of the first support member; and

a tong assembly for connecting the tubular with a second tubular.

39. The tubular handling system of claim 38, further comprising tong positioning device.

40. The tubular handling system of claim 39, wherein the tong positioning device comprises a single extendable beam having variable length.

41. The tubular handling system of claim 1, wherein the first portion and the second portion are radially displaced from each other.

42. The tubular handling system of claim 1, wherein the first portion and the second portion comprise two different locations of the shoulder.

1/22

FIG. 1

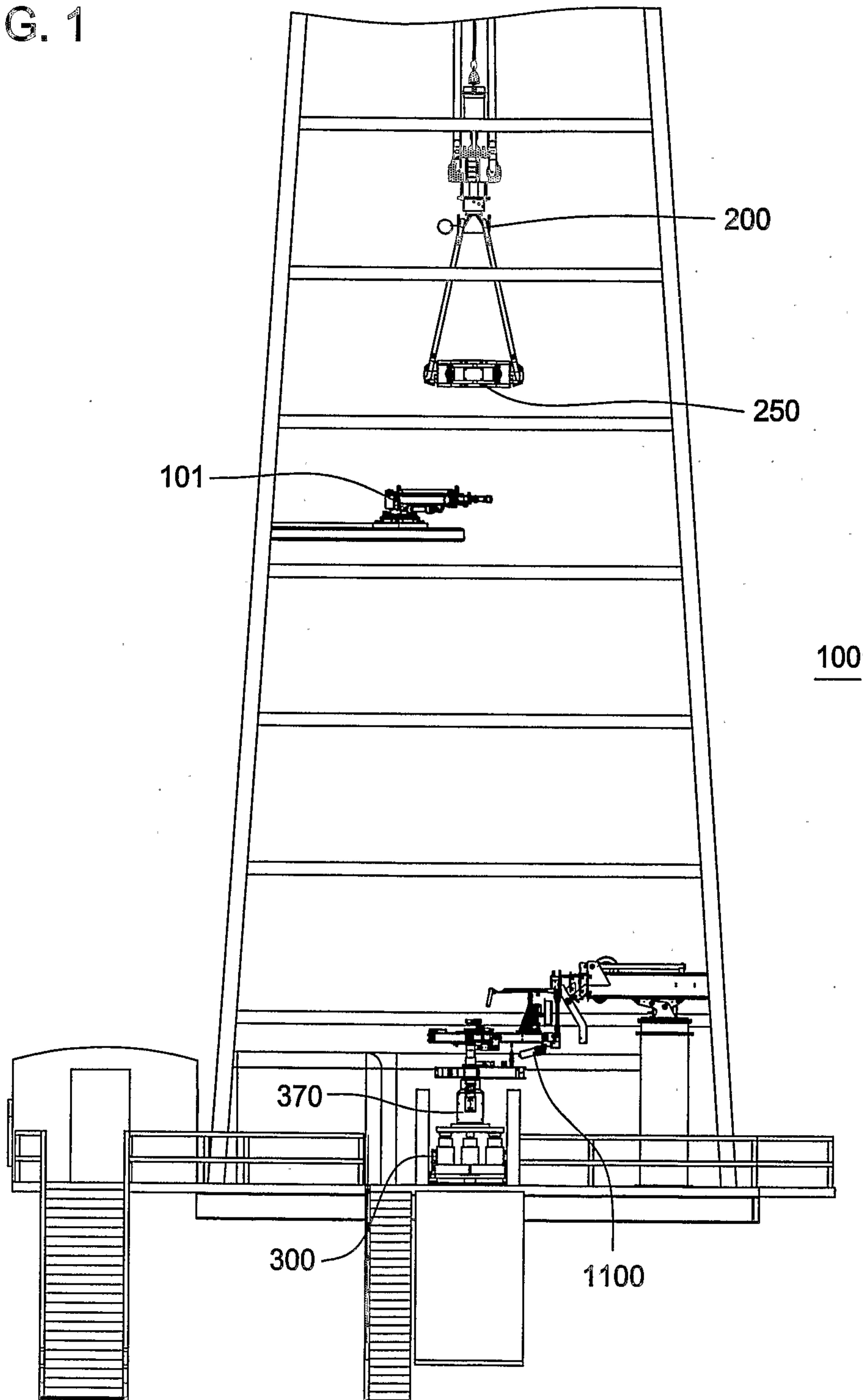

2/22

FIG. 2

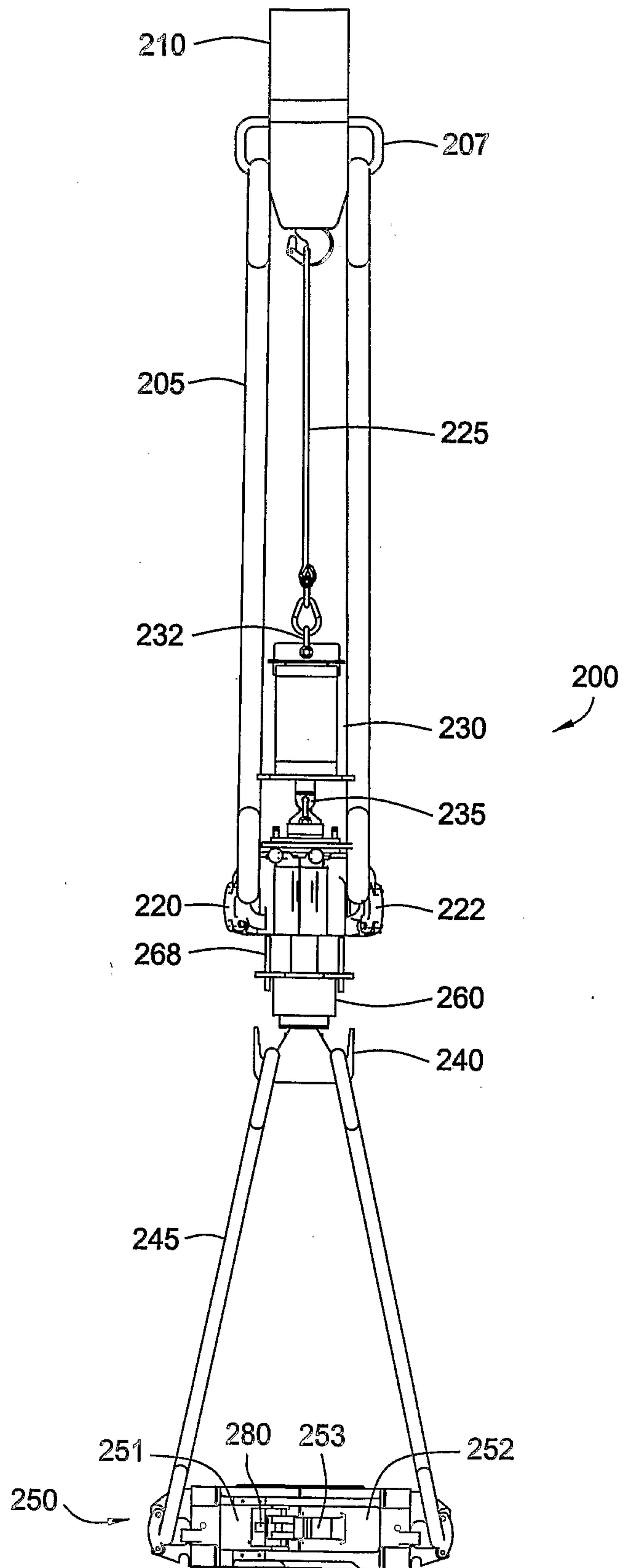

3/22

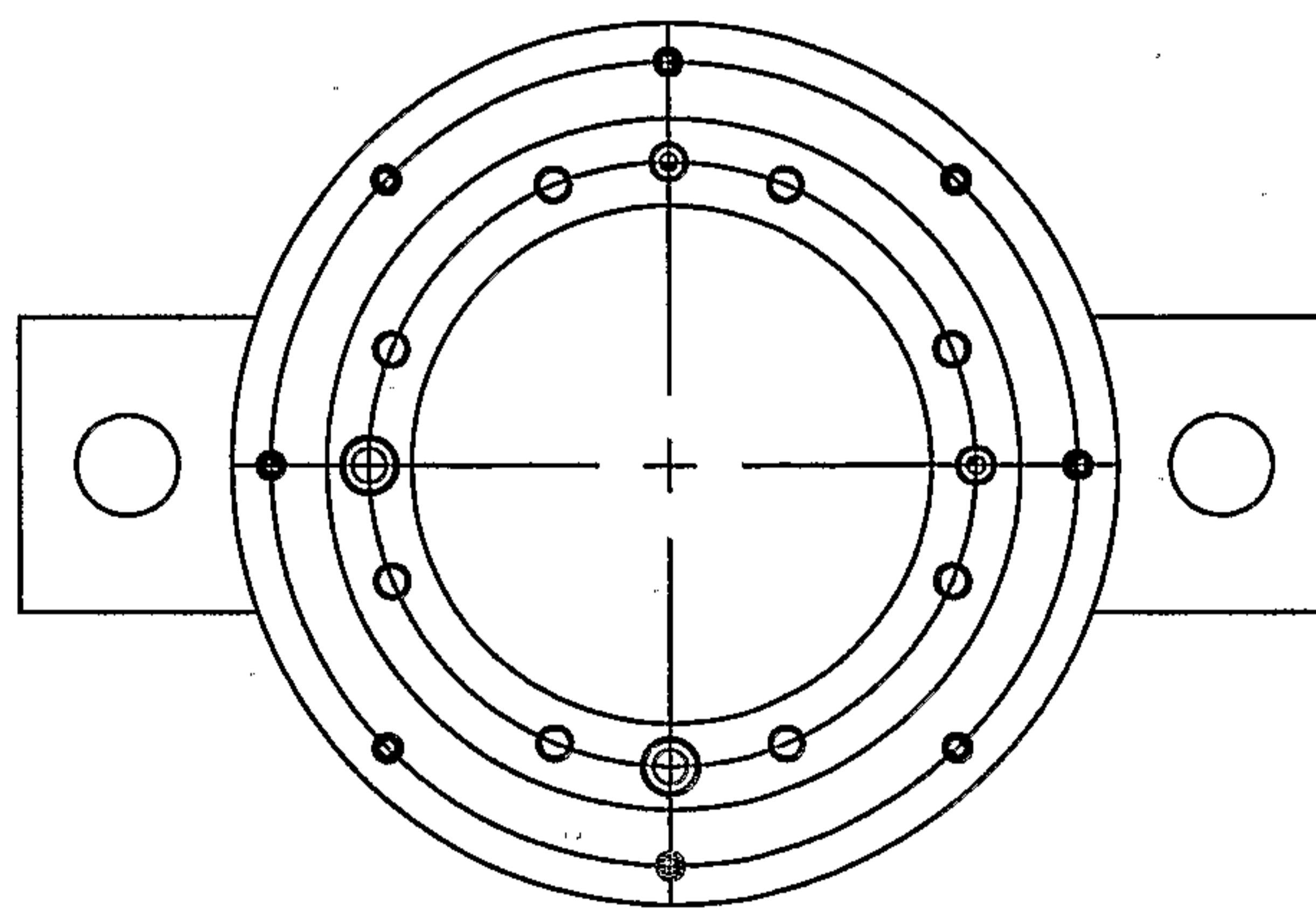
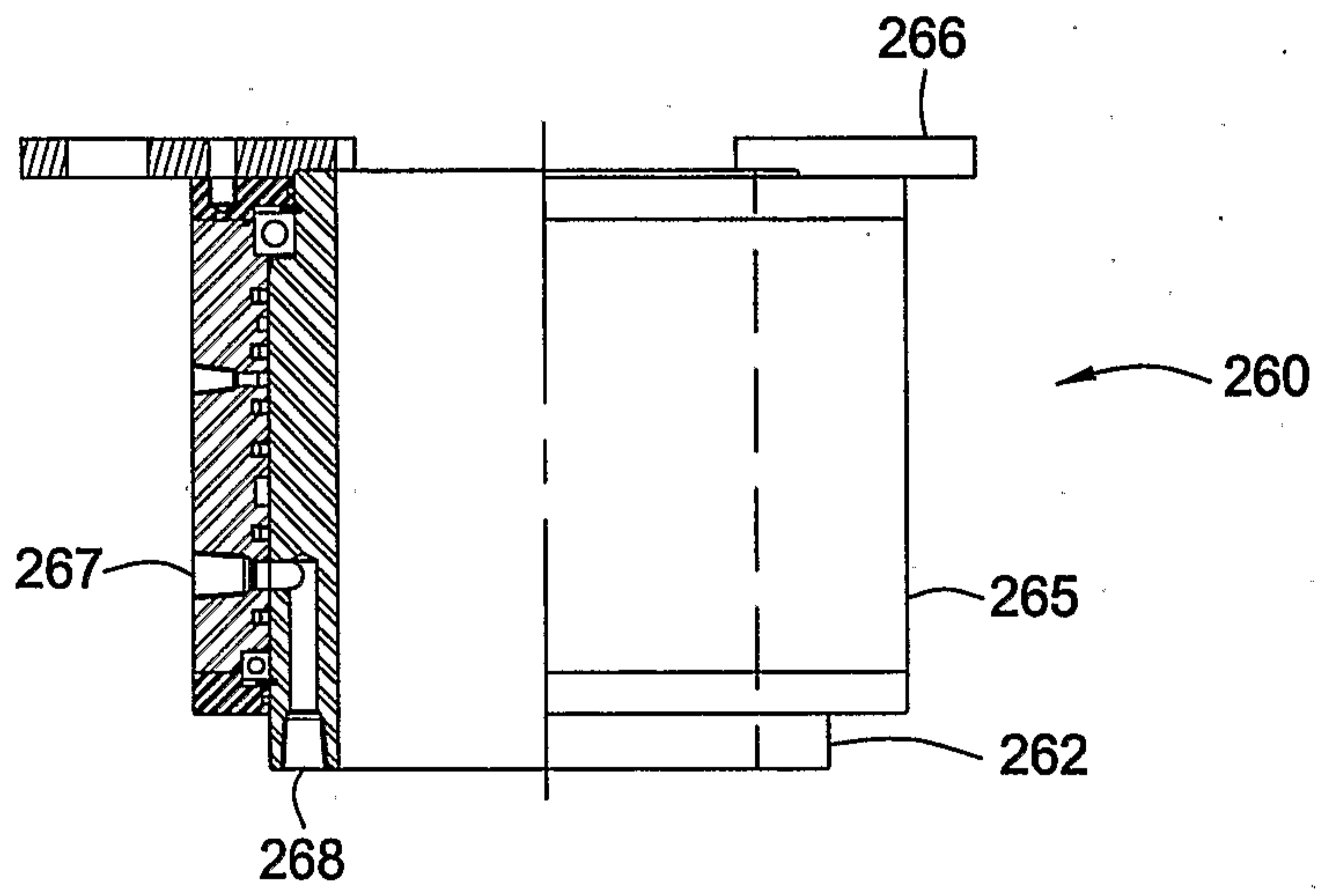
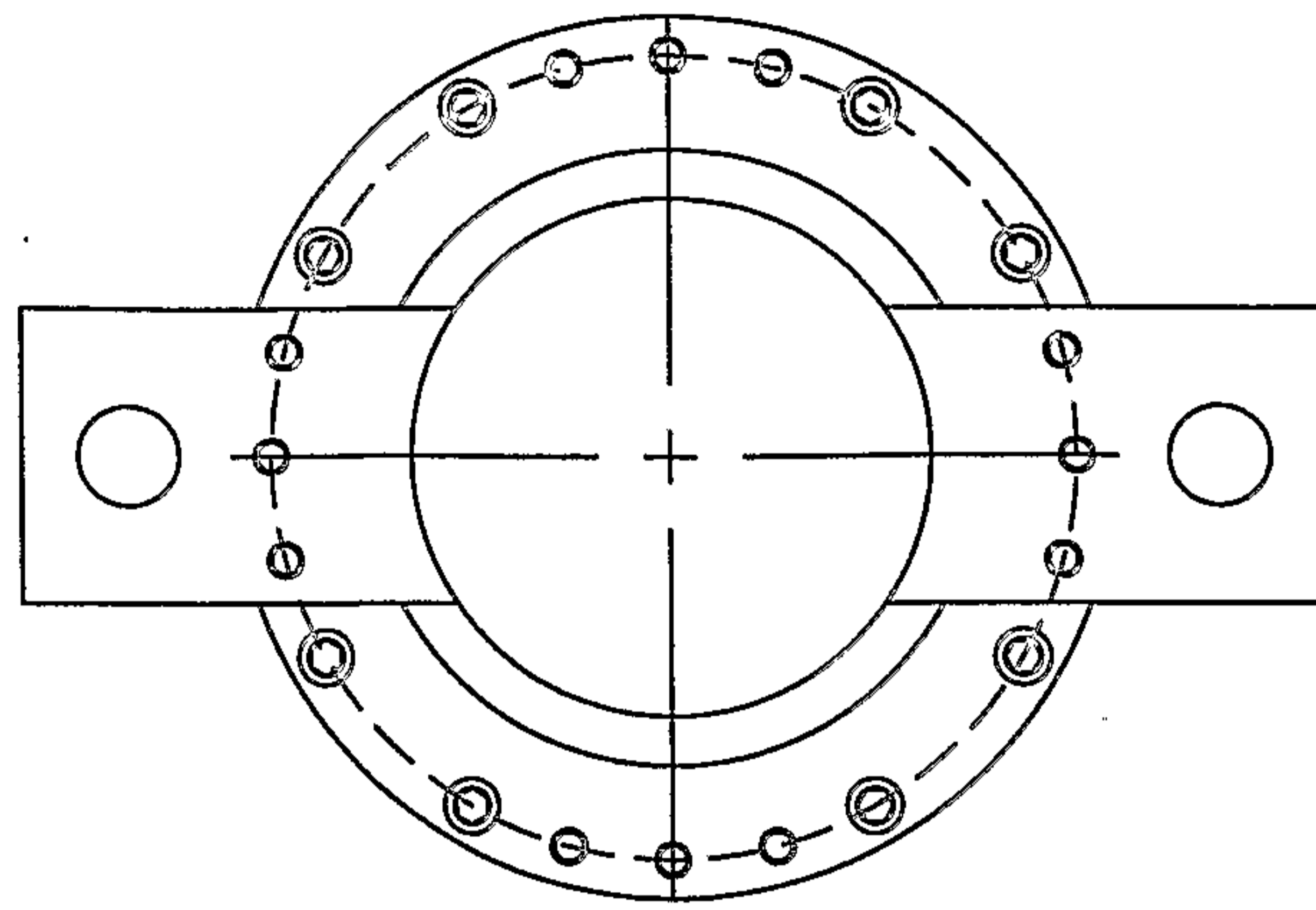

FIG. 3

4/22

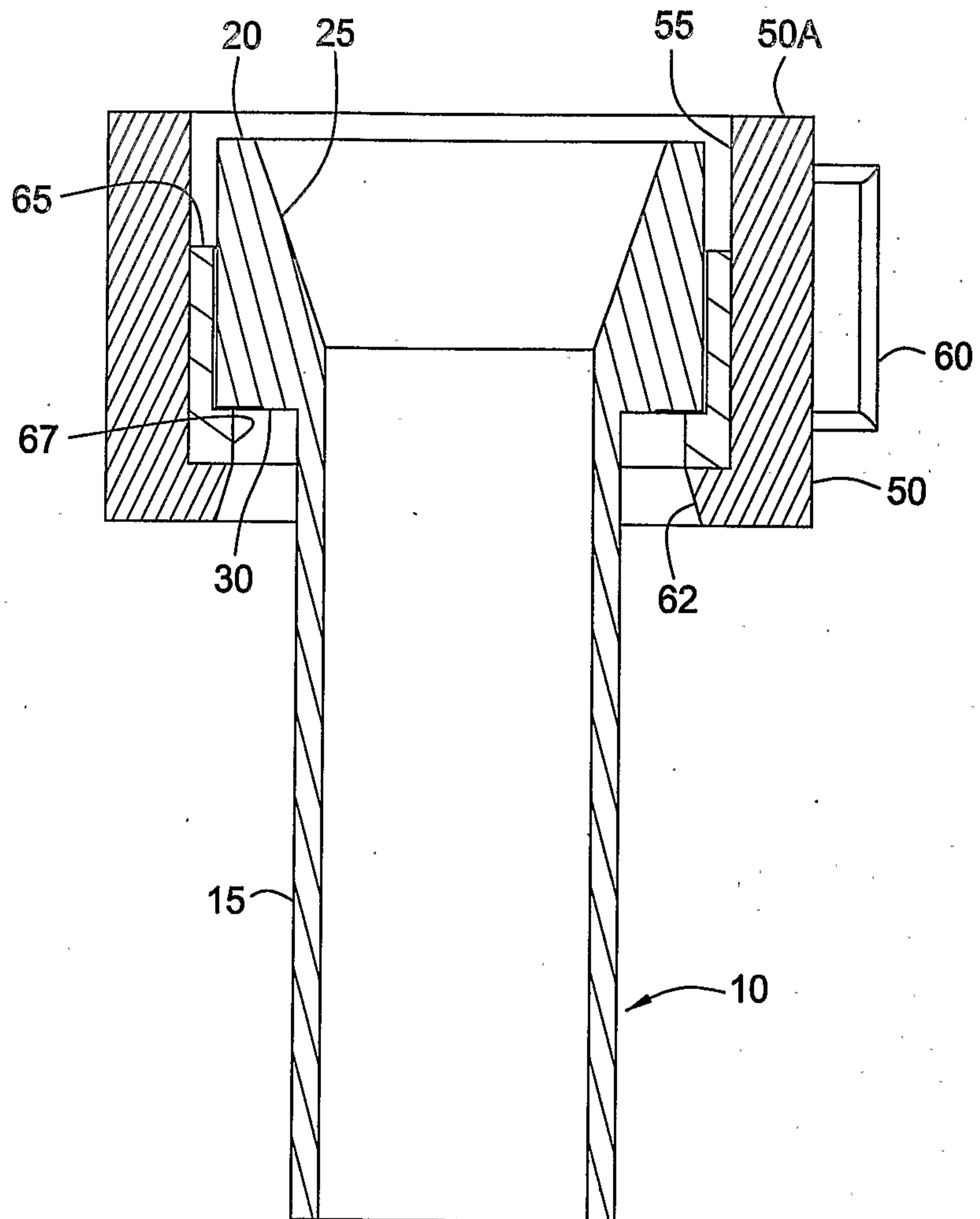

FIG. 4

5/22

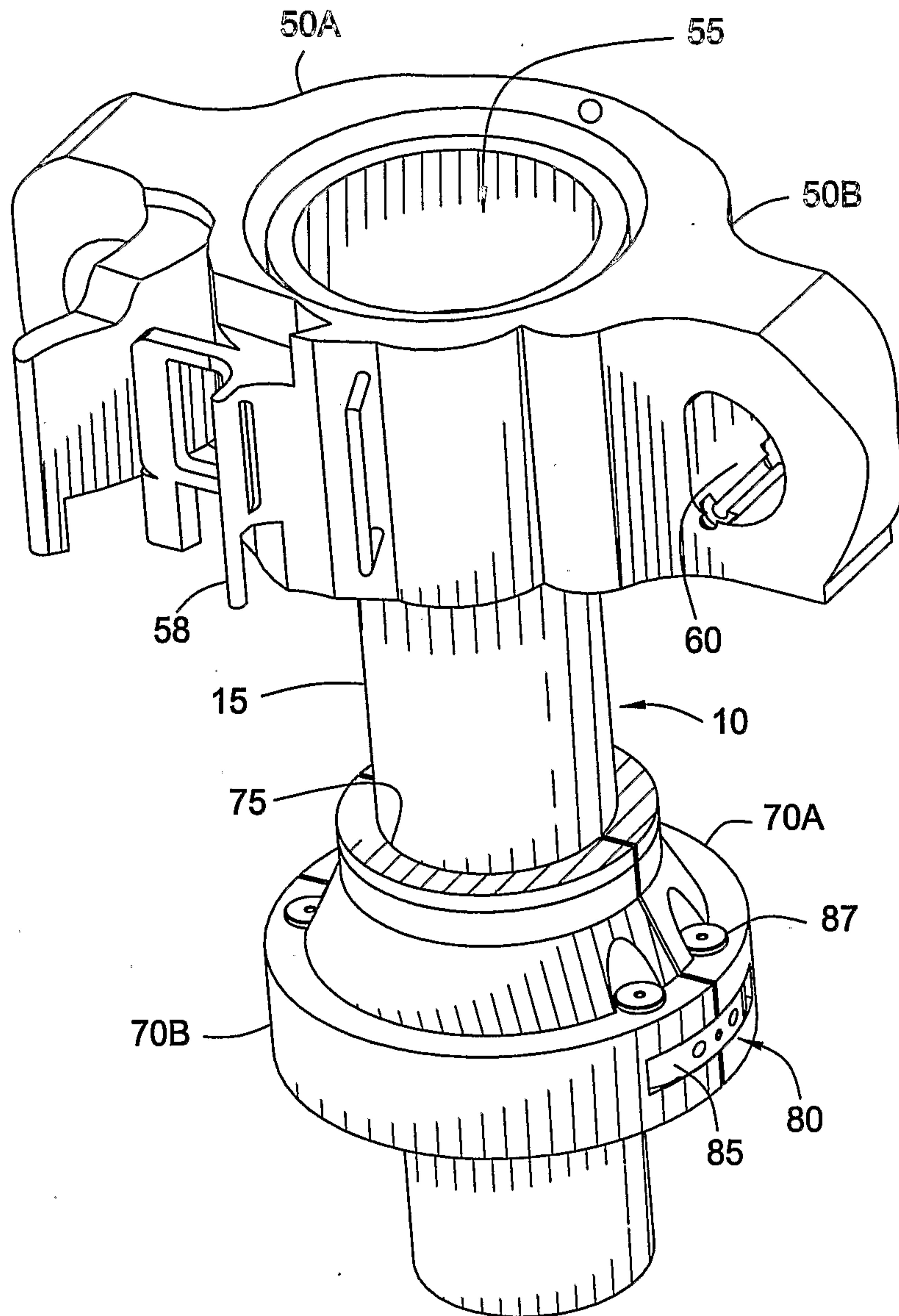

FIG. 5

6/22

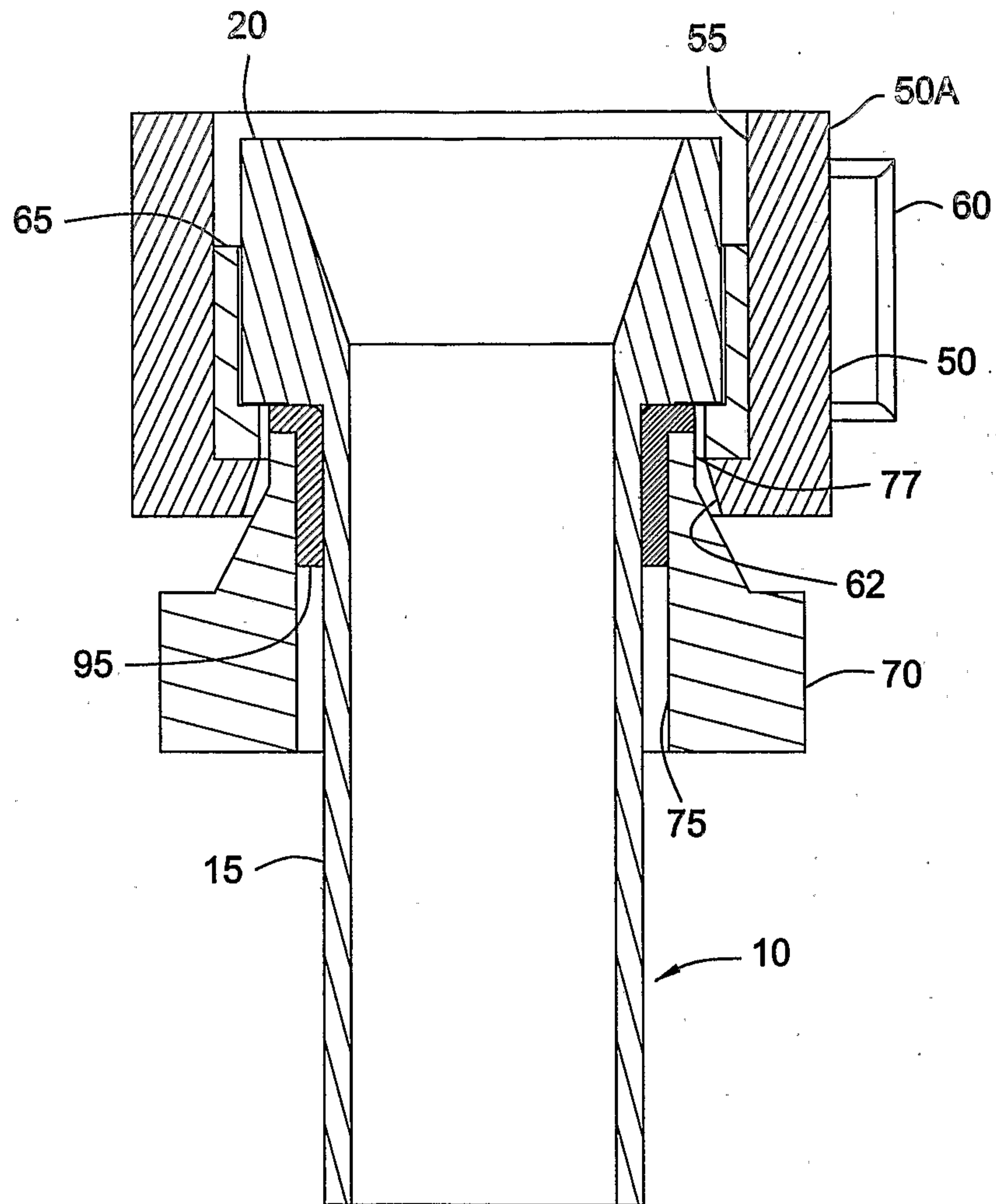

FIG. 6

7/22

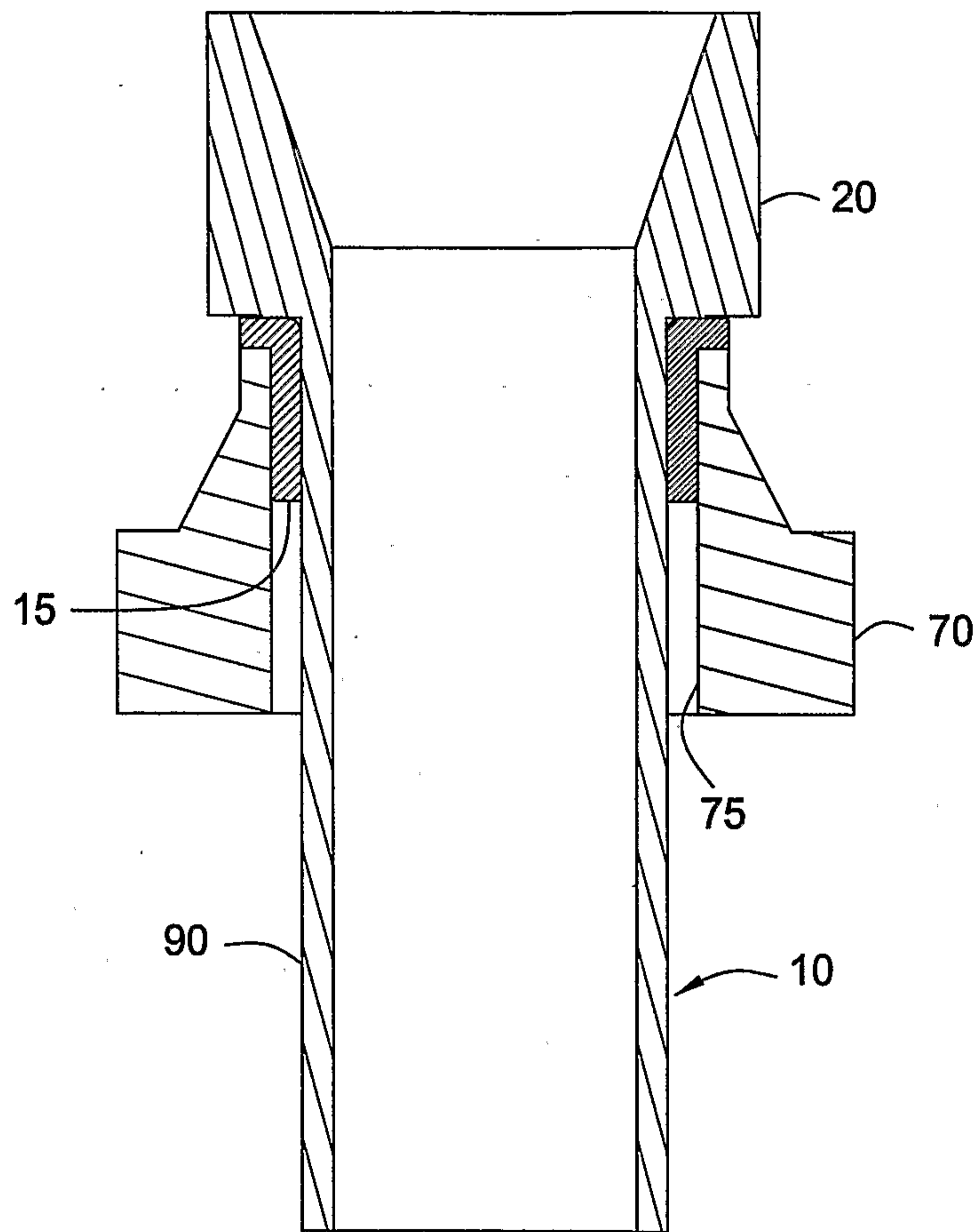

FIG. 7

8/22

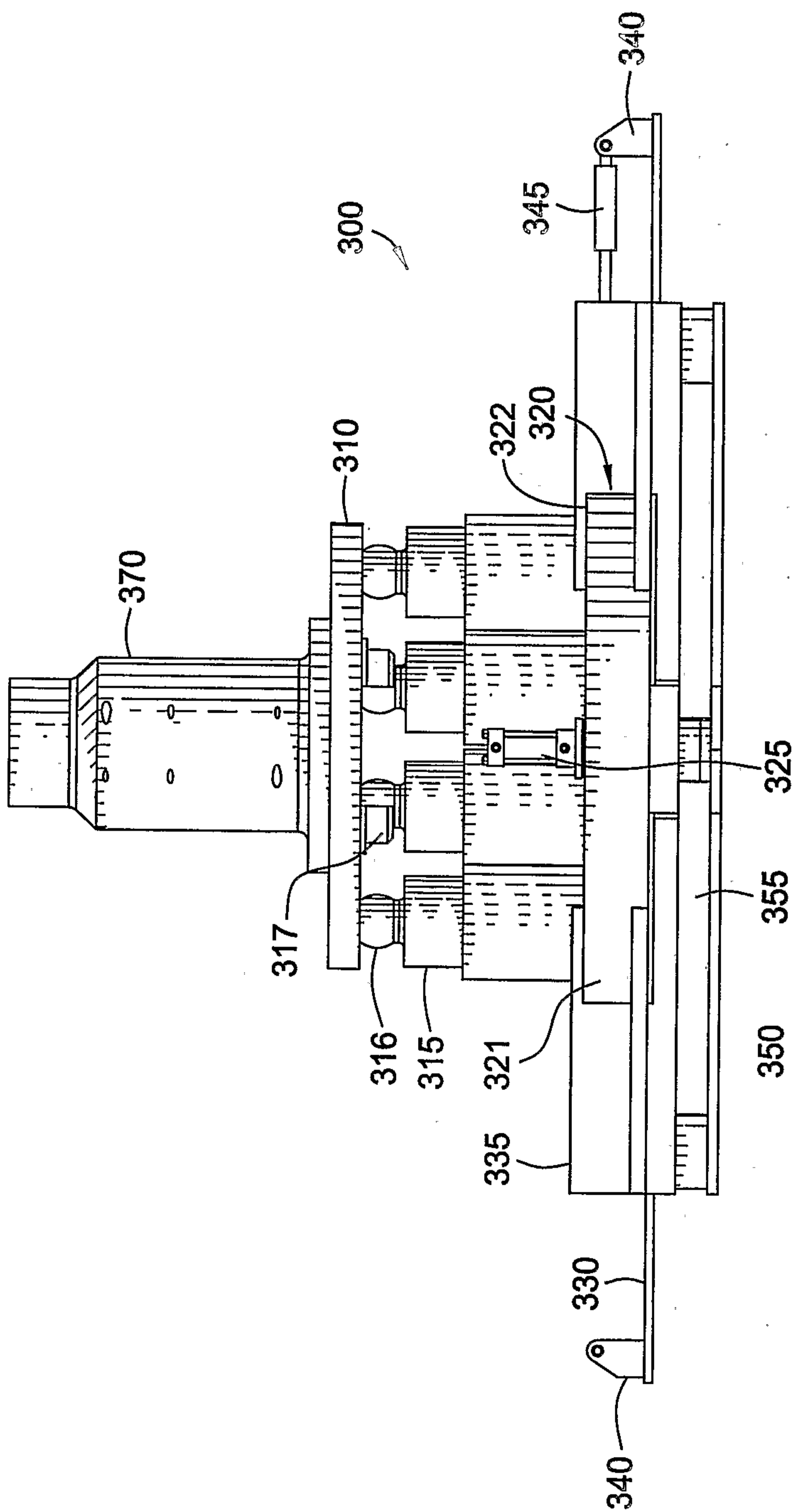

FIG. 8

9/22

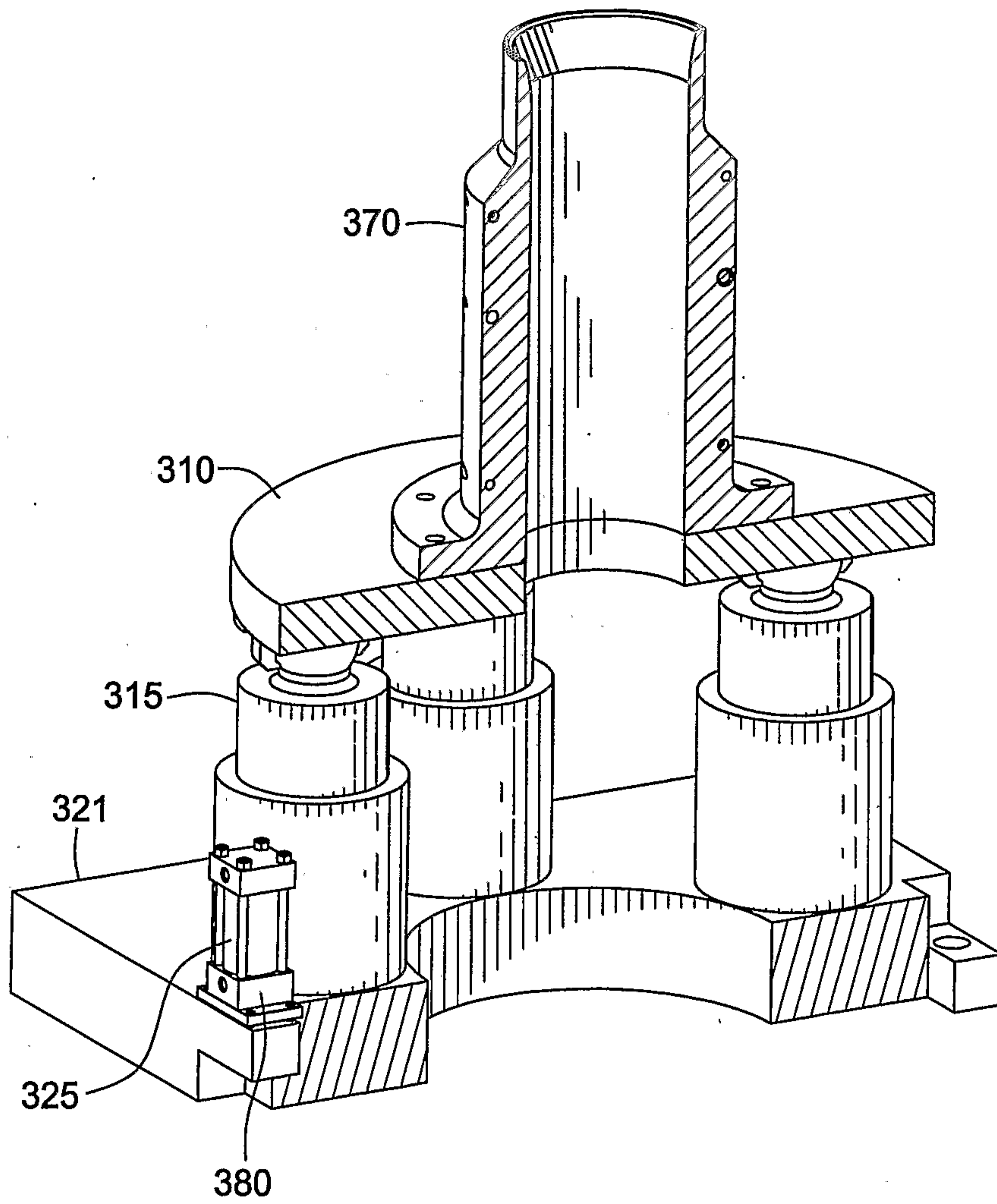

FIG. 9

10/22

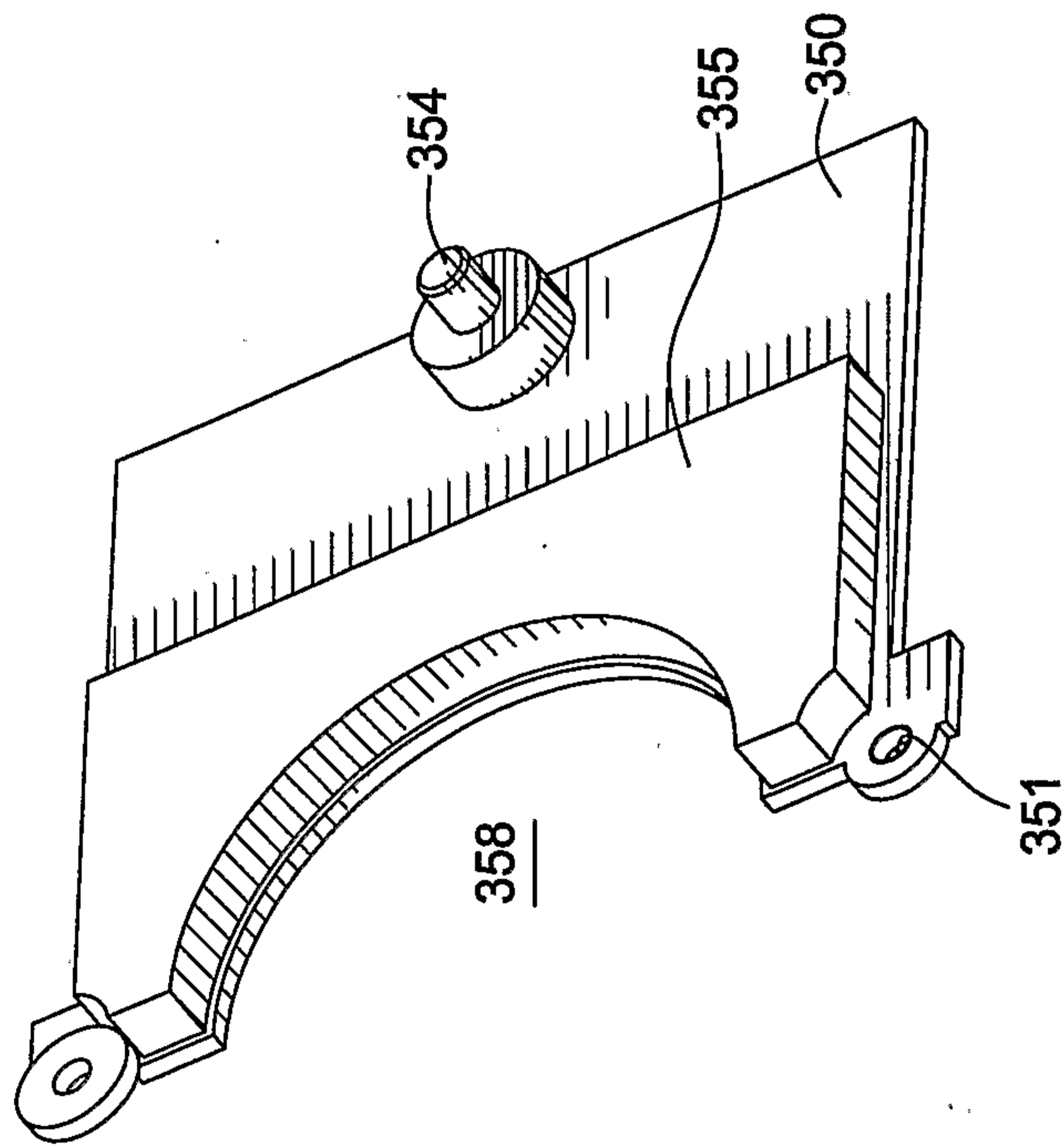

FIG. 10

11/22

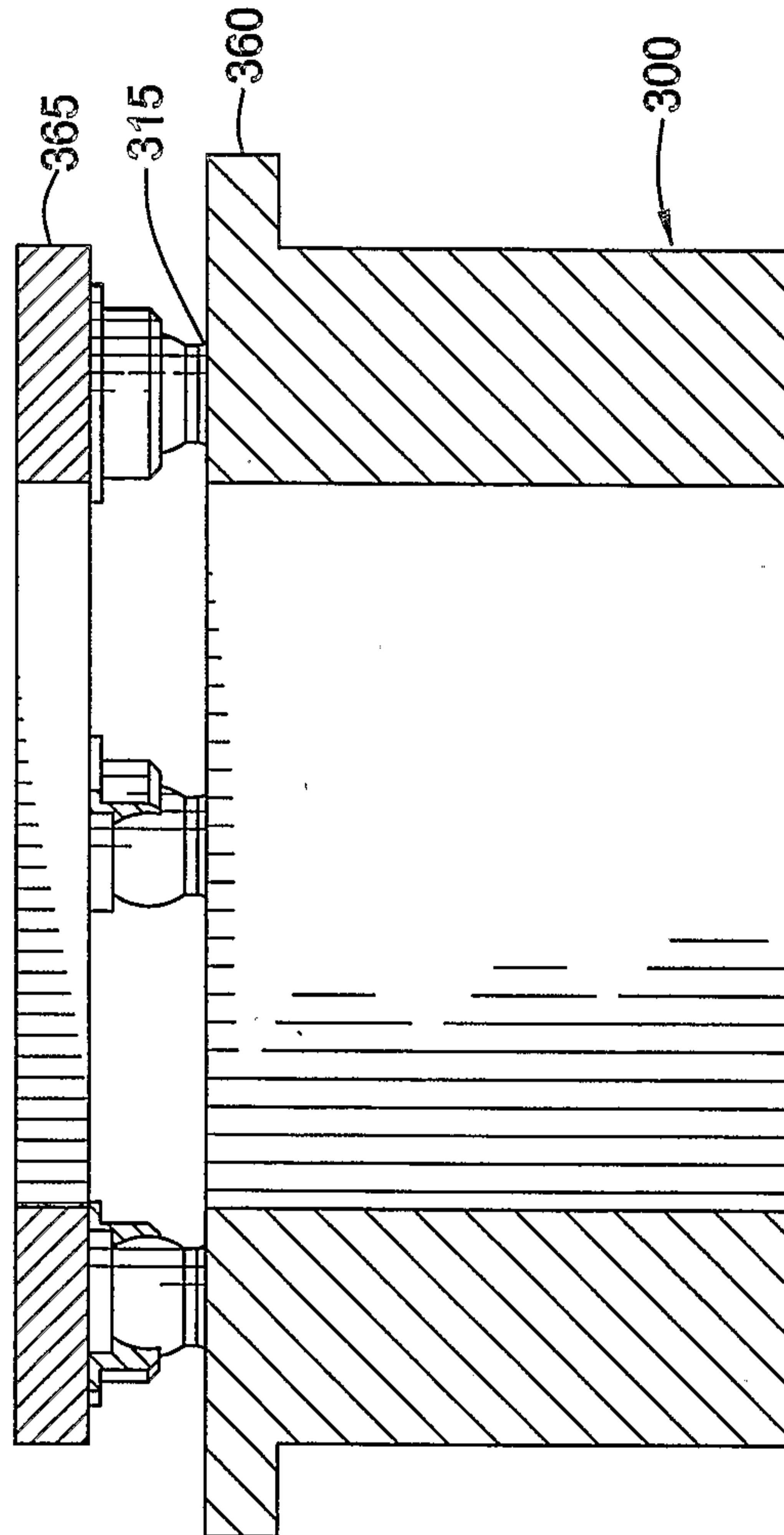

FIG. 11

12/22

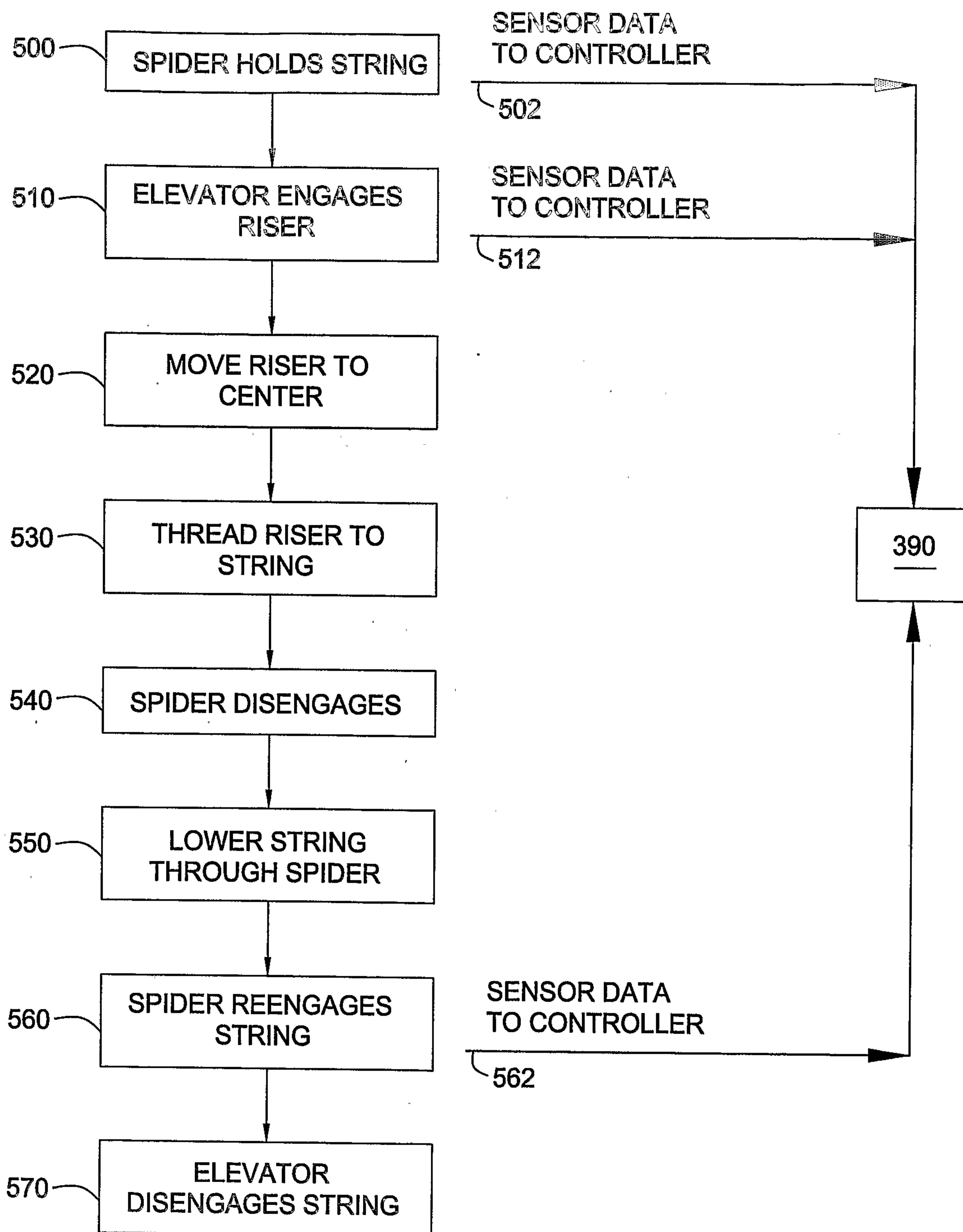
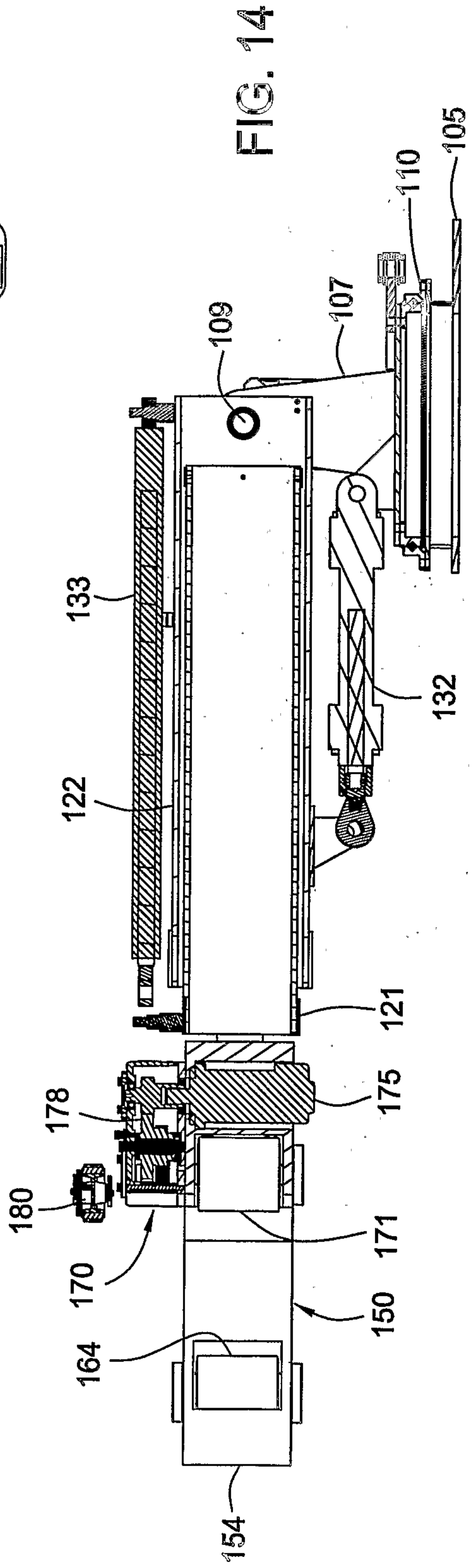
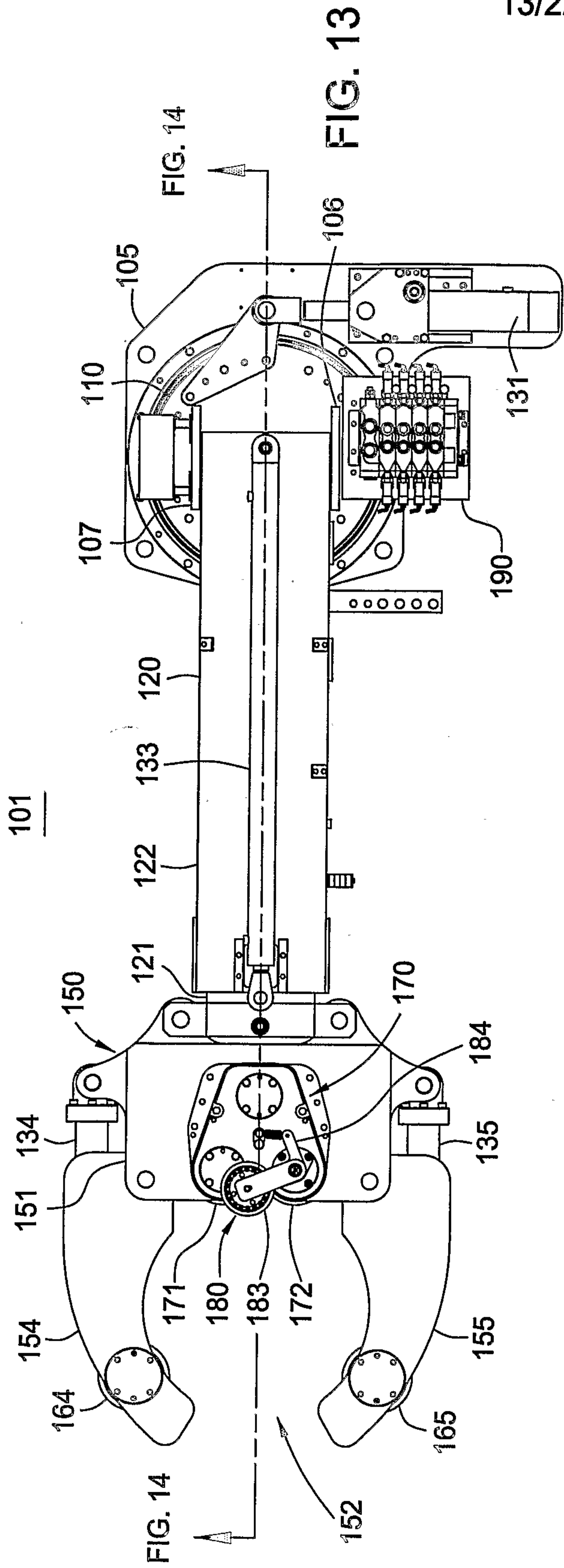

FIG. 12



14/22

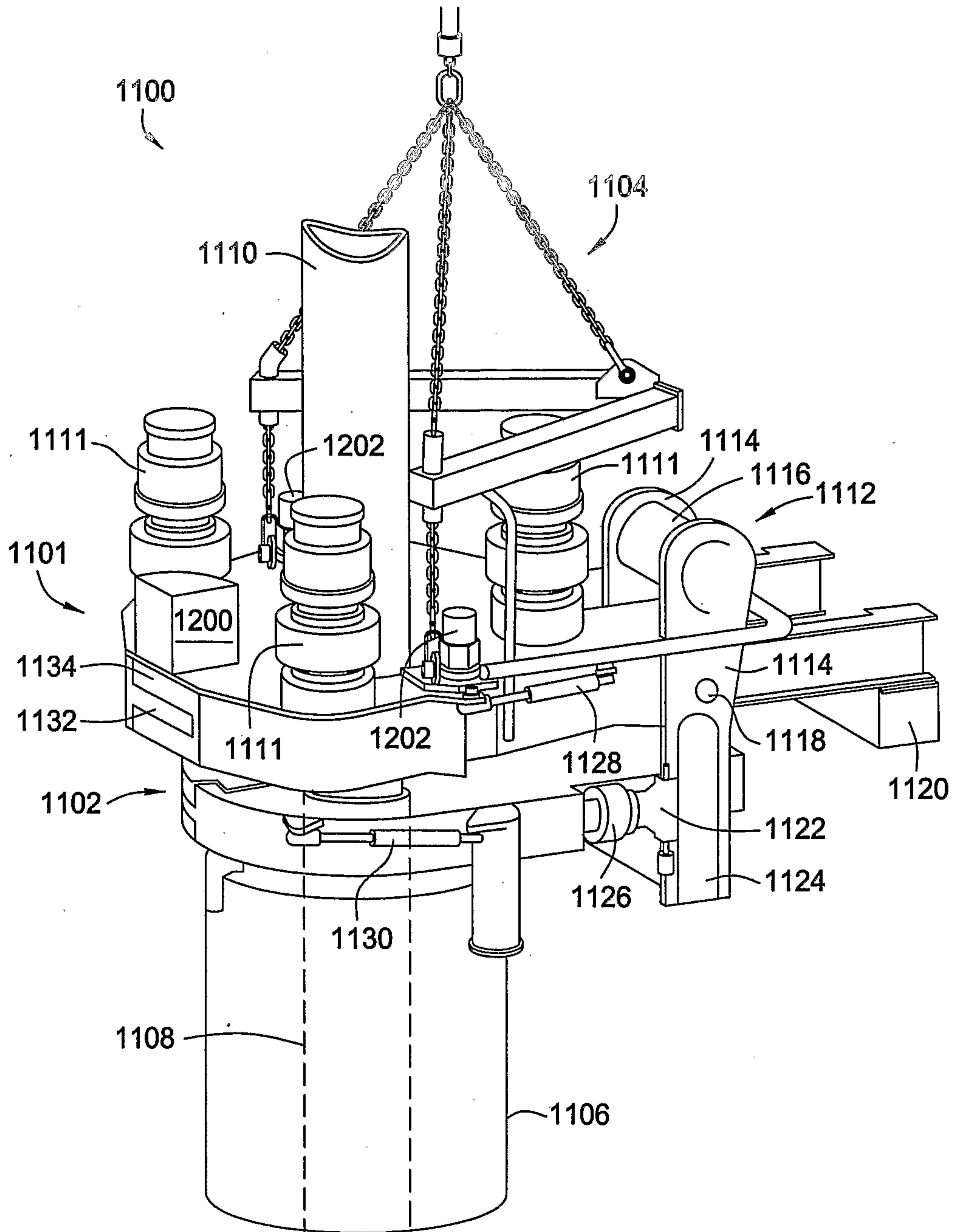

FIG. 15

15/22

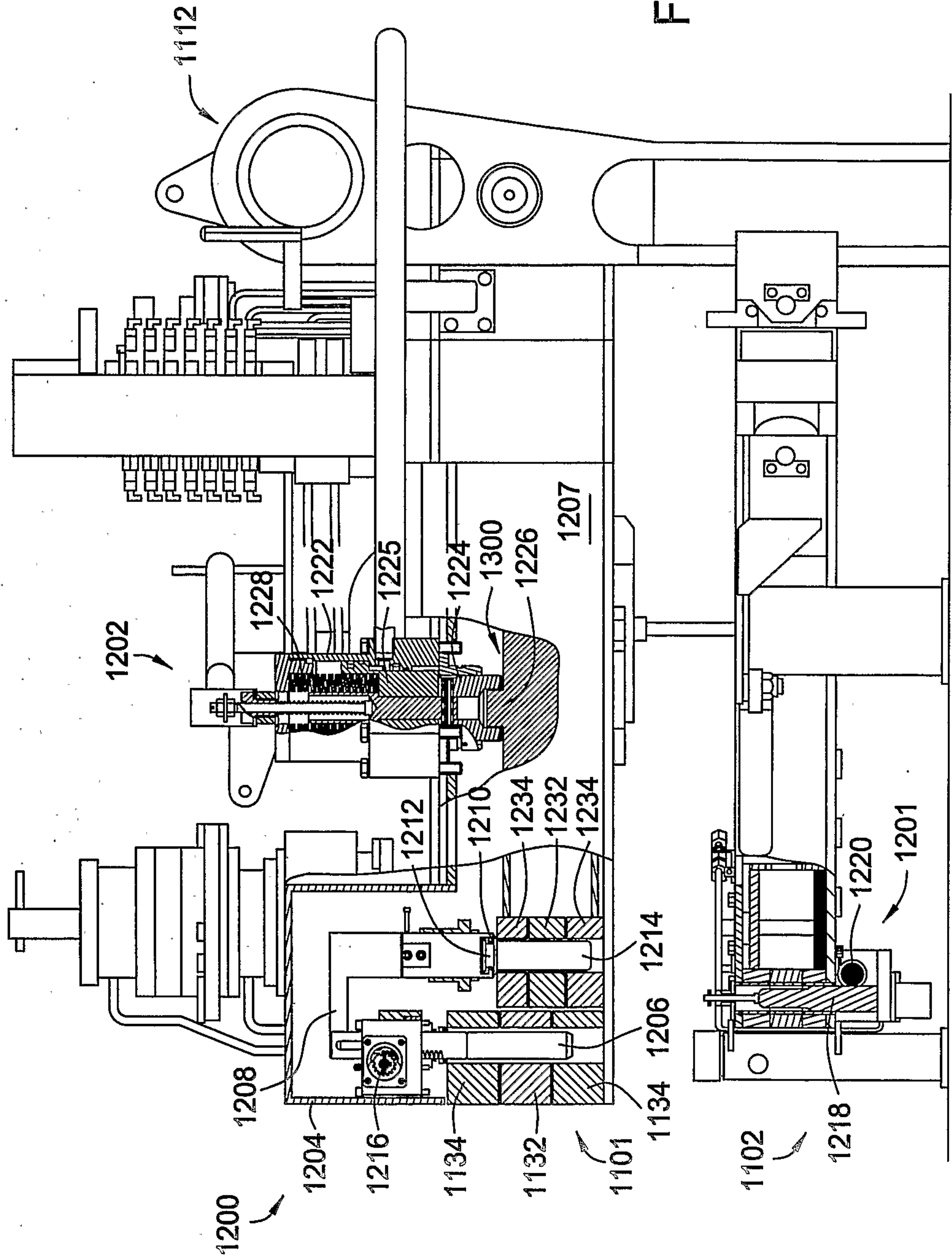

FIG. 16

16/22

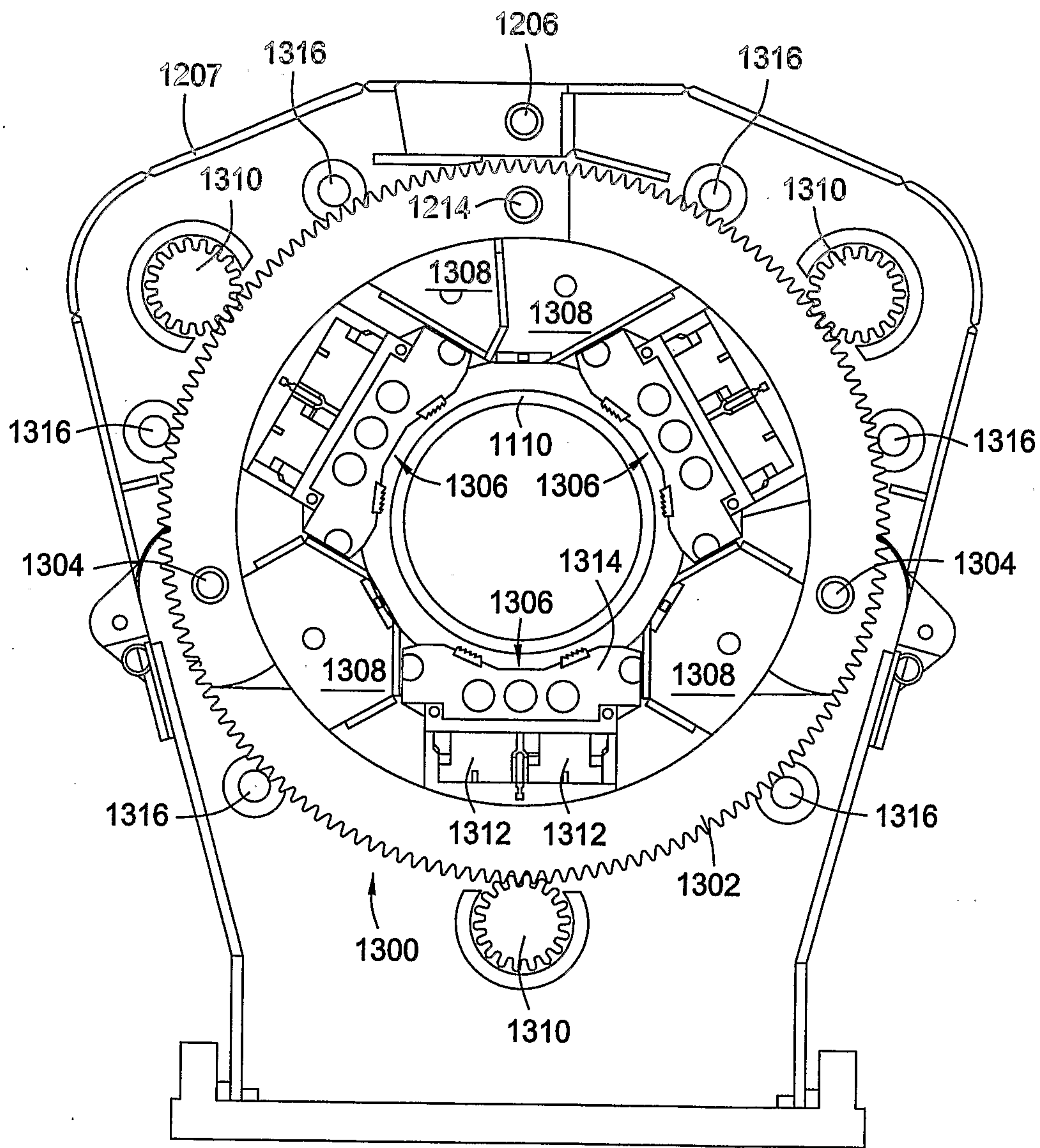

FIG. 17

17/22

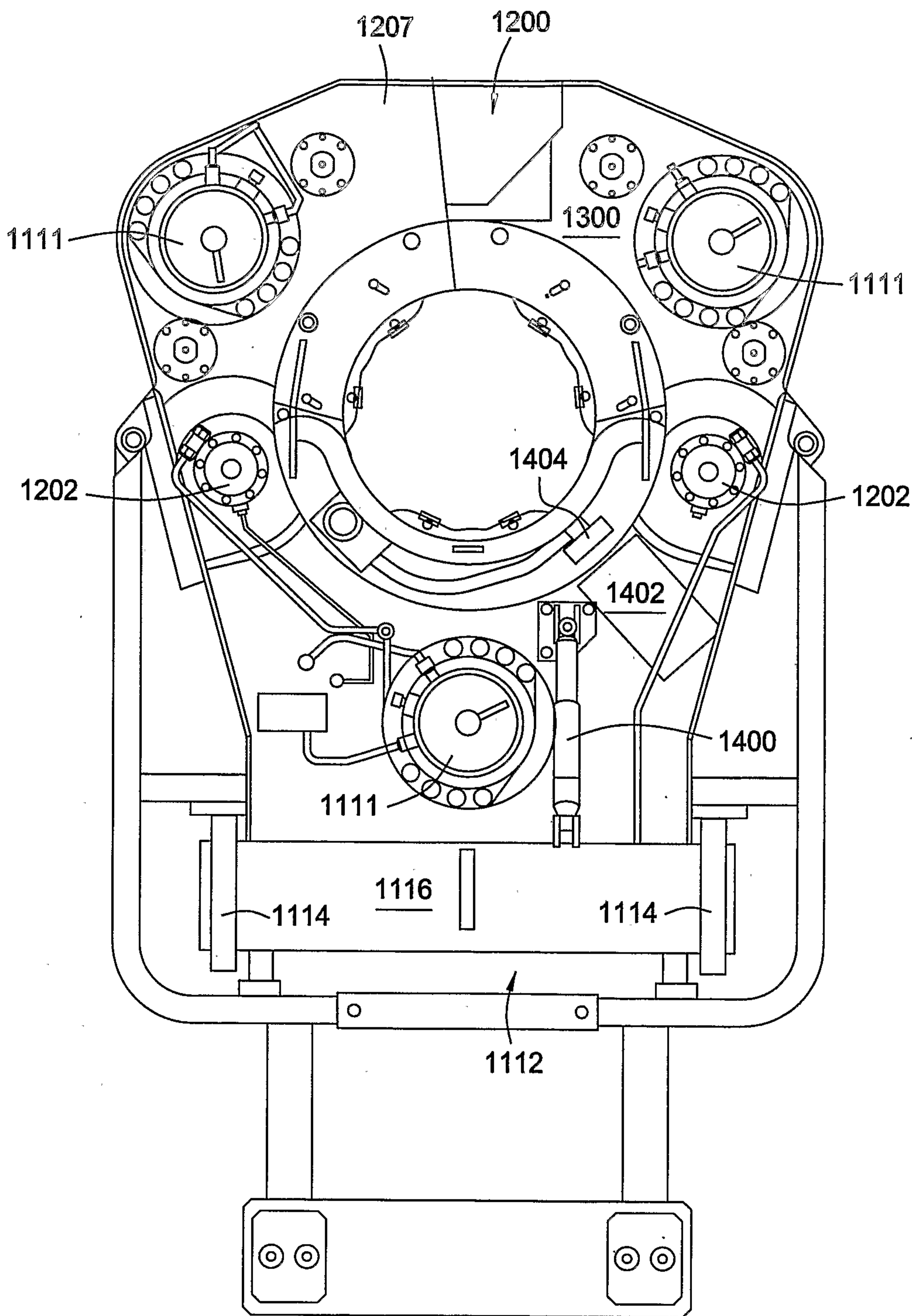

FIG. 18

18/22

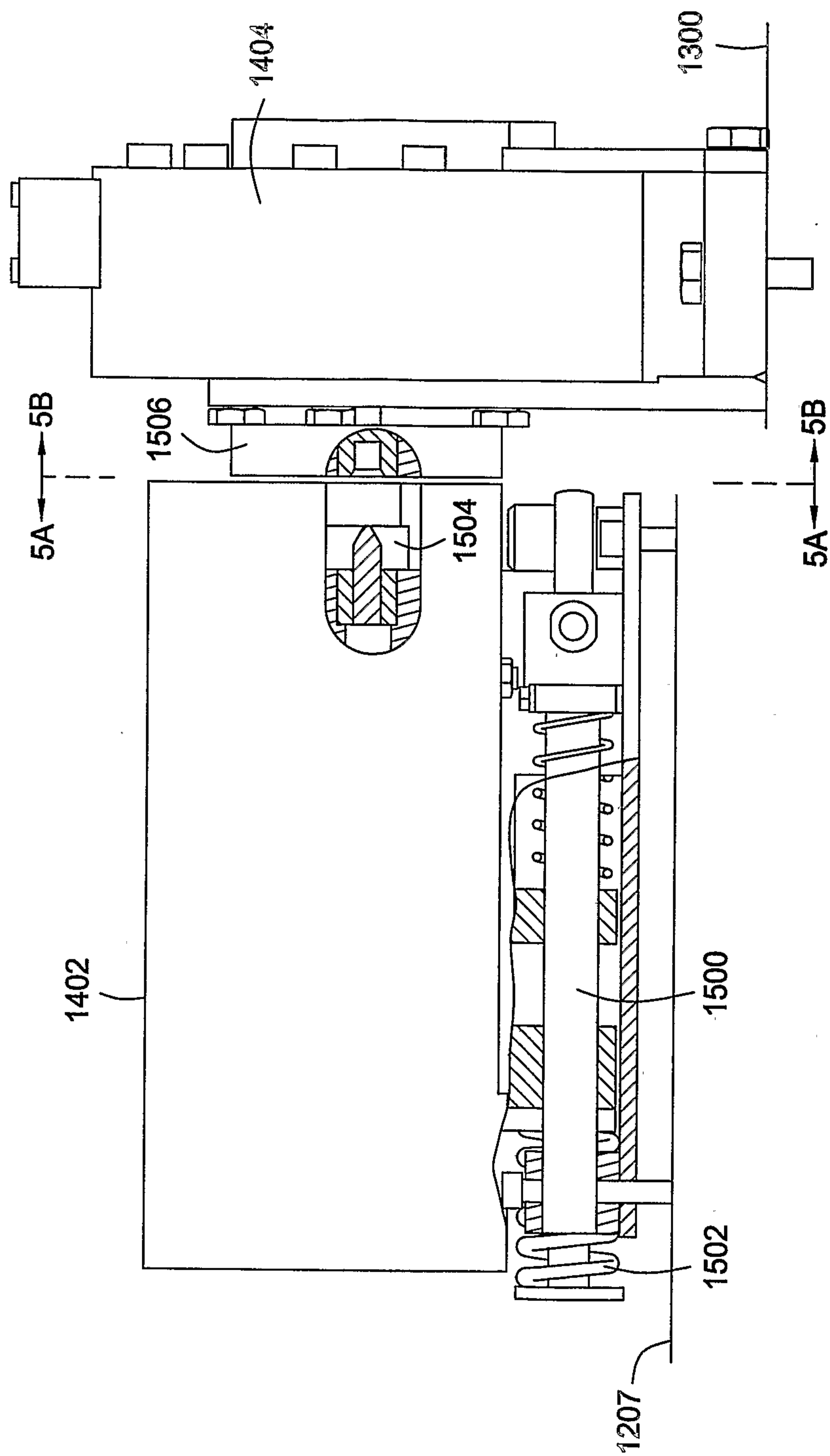

FIG. 19

19/22

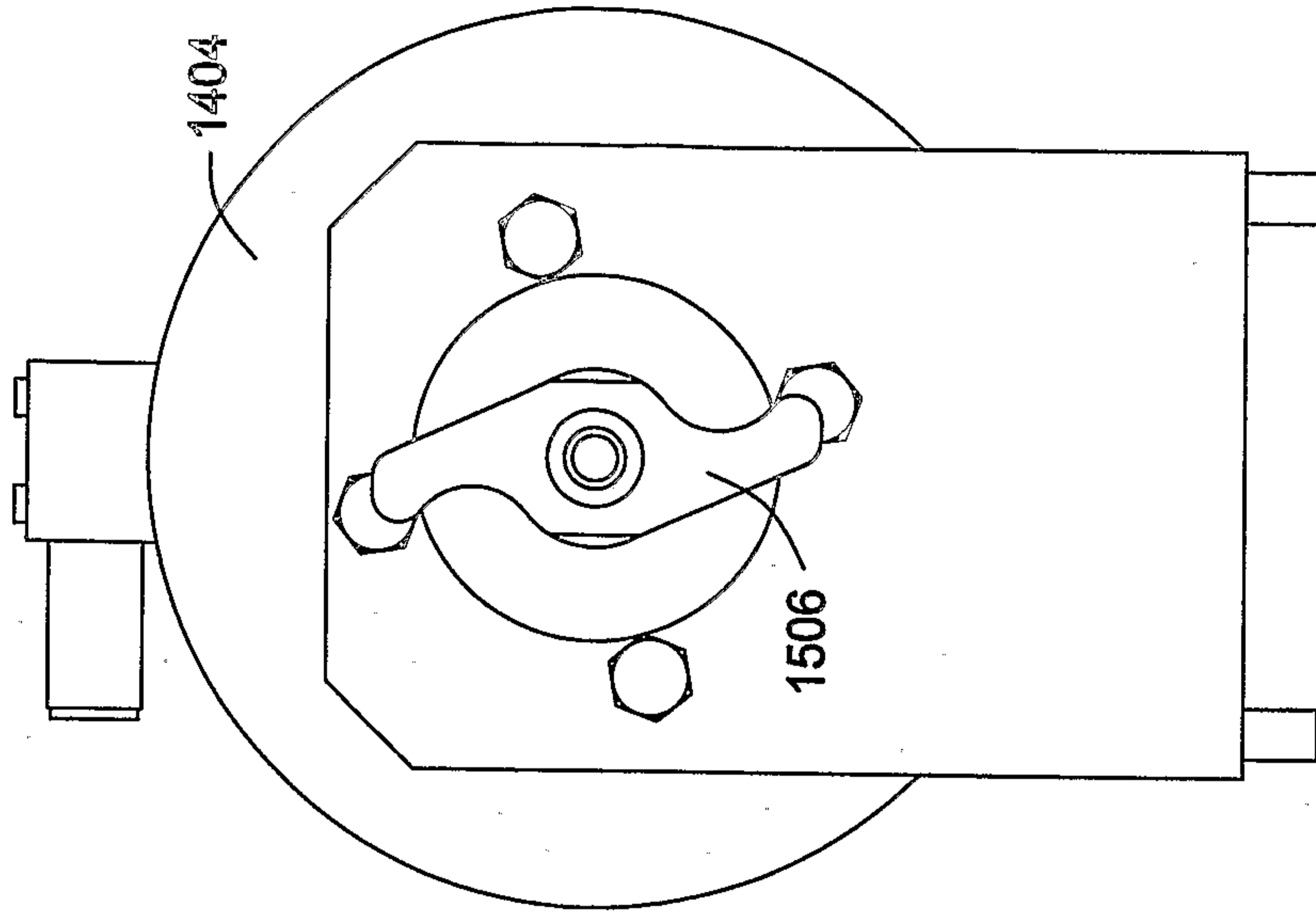

FIG. 19B

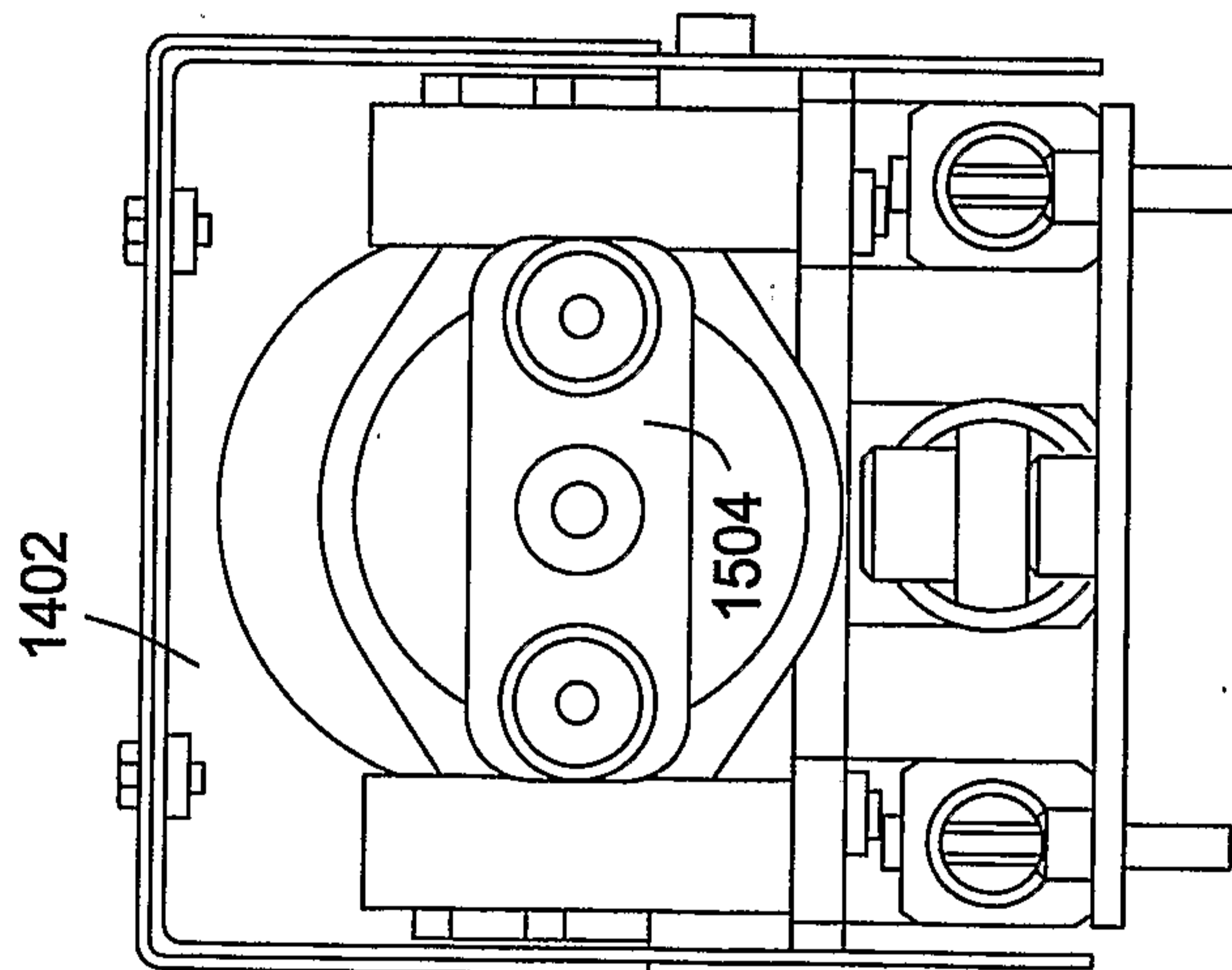

FIG. 19A

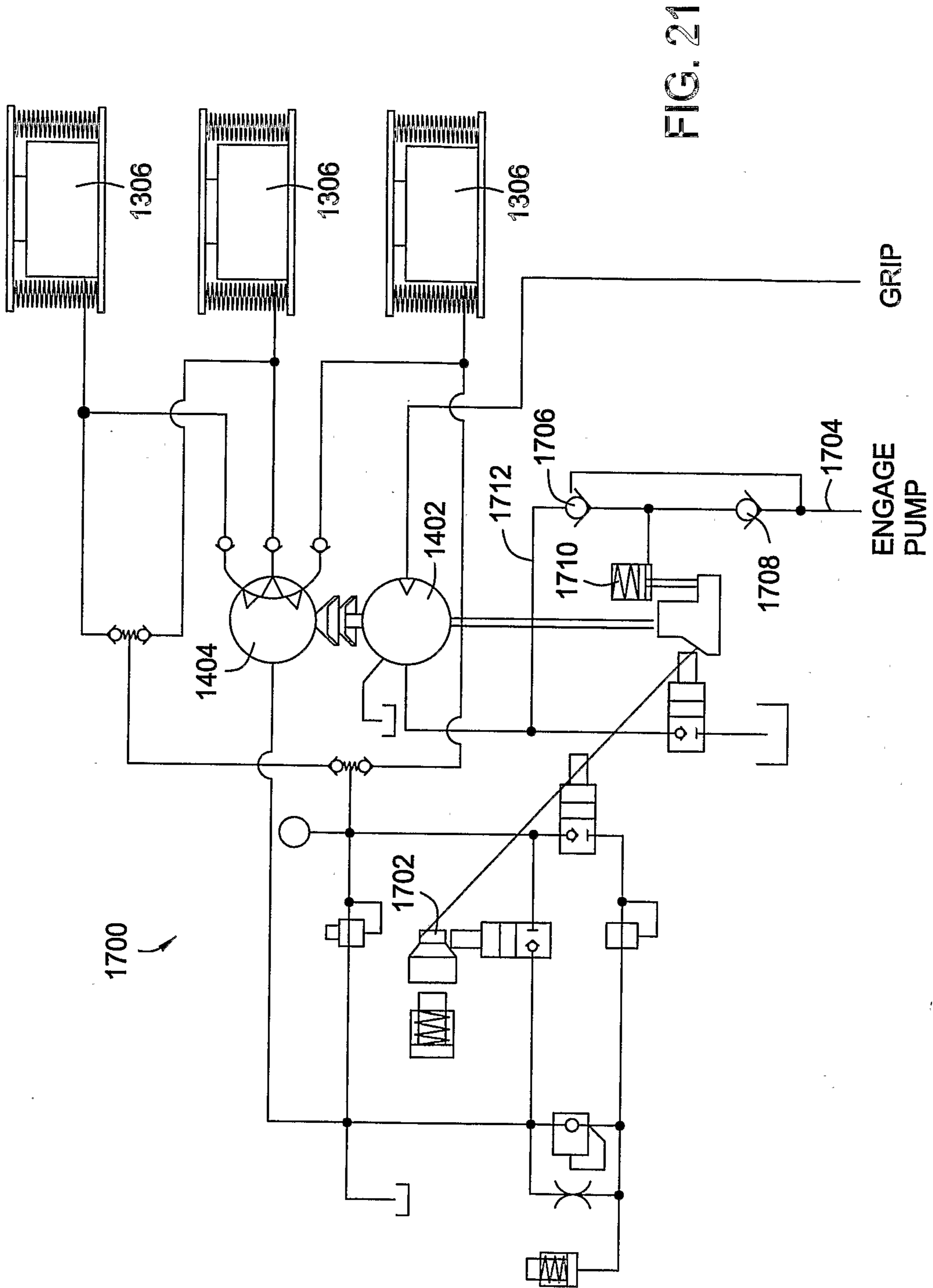

FIG. 21

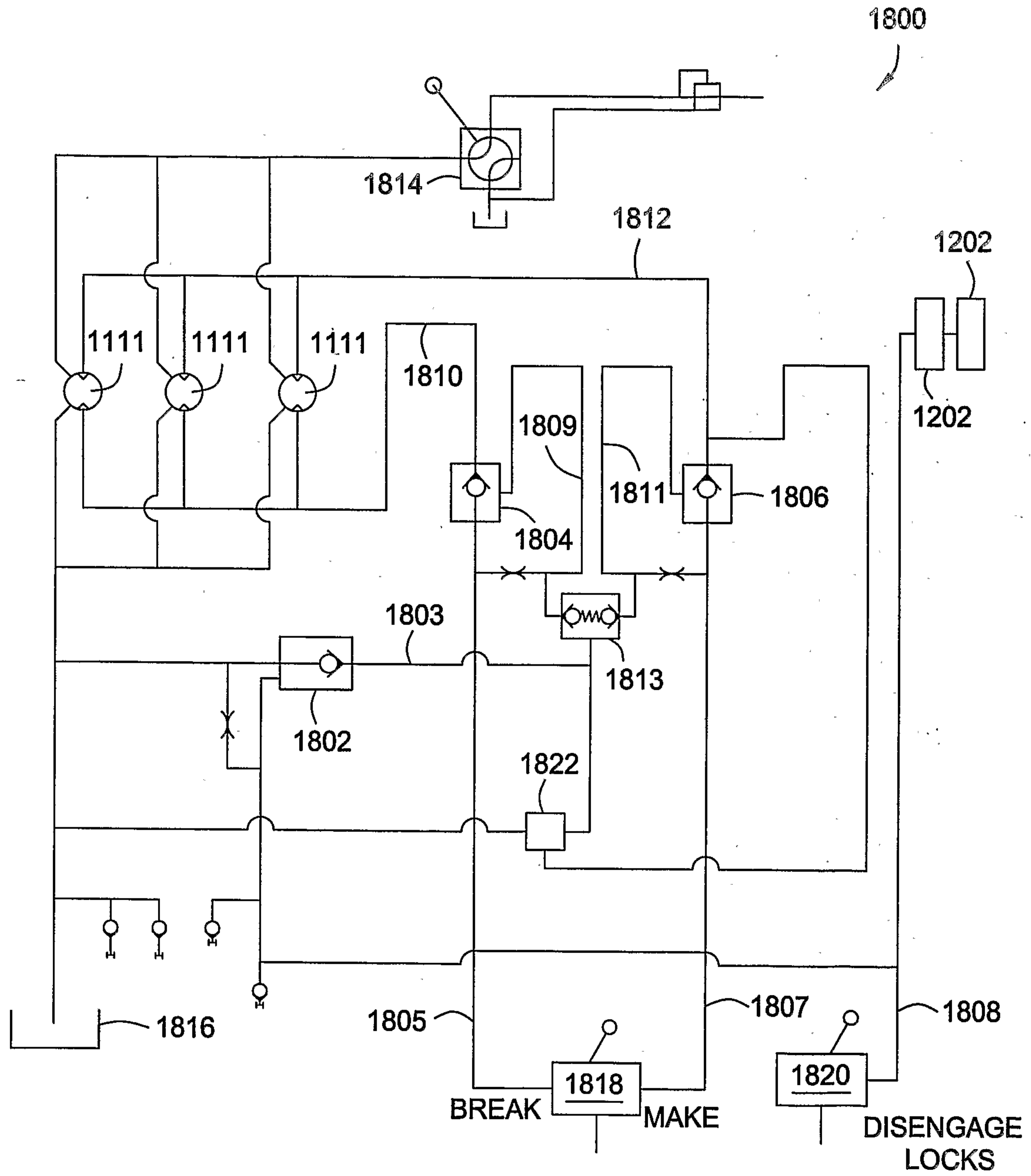

FIG. 22

