

(12) **United States Patent**
Cocagne et al.

(10) **Patent No.:** **US 11,410,019 B1**
(45) **Date of Patent:** ***Aug. 9, 2022**

(54) **VERIFYING SYSTEM REGISTRY FILES IN A STORAGE NETWORK**

(71) Applicant: **Pure Storage, Inc.**, Mountain View, CA (US)

(72) Inventors: **Thomas D. Cocagne**, Elk Grove Village, IL (US); **Jason K. Resch**, Chicago, IL (US)

(73) Assignee: **PURE STORAGE, INC.**, Mountain View, CA (US)

(*) Notice: Subject to any disclaimer, the term of this patent is extended or adjusted under 35 U.S.C. 154(b) by 98 days.

This patent is subject to a terminal disclaimer.

(21) Appl. No.: **16/986,599**

(22) Filed: **Aug. 6, 2020**

Related U.S. Application Data

(63) Continuation of application No. 16/145,481, filed on Sep. 28, 2018, now Pat. No. 10,748,055, which is a (Continued)

(51) **Int. Cl.**
GIIC 29/00 (2006.01)
G06N 3/04 (2006.01)
(Continued)

(52) **U.S. Cl.**
CPC **G06N 3/04** (2013.01); **G06F 3/064** (2013.01); **G06F 3/067** (2013.01); **G06F 3/0619** (2013.01);
(Continued)

(58) **Field of Classification Search**
CPC G06F 11/079; G06F 11/0727; G06F 11/0751; G06F 11/0769; G06F 11/1092; G06F 3/0619; G06F 3/064; G06F 3/067
See application file for complete search history.

(56) **References Cited**
U.S. PATENT DOCUMENTS

4,092,732 A 5/1978 Ouchi
5,454,101 A 9/1995 Mackay et al.
(Continued)

OTHER PUBLICATIONS

Chung; An Automatic Data Segmentation Method for 3D Measured Data Points; National Taiwan University; pp. 1-8; 1998.
(Continued)

Primary Examiner — Samir W Rizk
(74) *Attorney, Agent, or Firm* — Garlick & Markison; Timothy W. Markison; Bruce E. Stuckman

(57) **ABSTRACT**

A method for execution by a dispersed storage and task (DST) execution unit includes receiving system registry integrity data via a network that corresponds to a plurality of system registry files, a request for a subset of the plurality of system registry files is generated for transmission to a dispersed storage network (DSN) unit via the network. The subset of system registry files are received from the DSN unit via the network. Integrity check data is generated based on the received subset of the plurality of system registry files and the system registry integrity data, where the integrity check data includes a verification indicator. The system registry files are stored in memory when the verification indicator indicates that verification was successful.

20 Claims, 7 Drawing Sheets

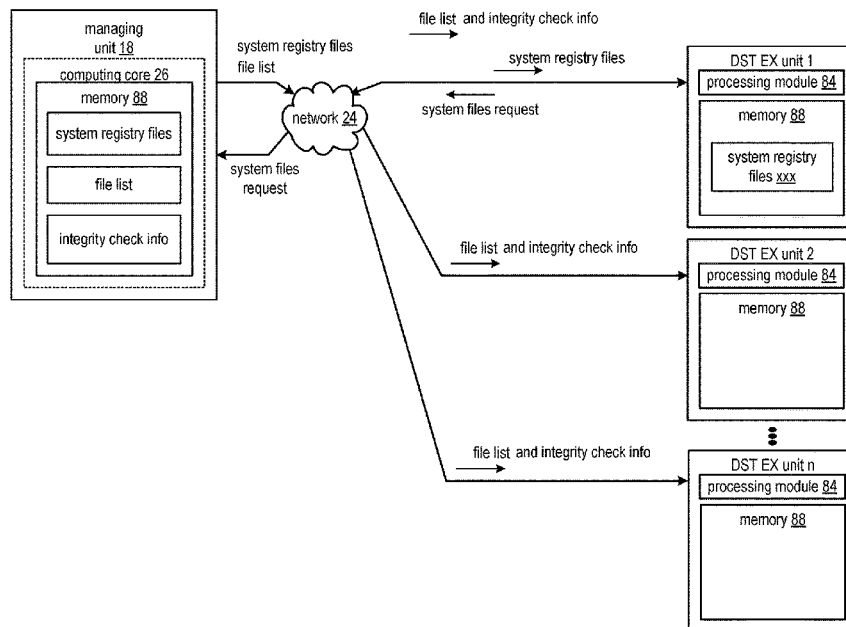

Related U.S. Application Data

continuation of application No. 15/262,808, filed on Sep. 12, 2016, now Pat. No. 10,157,094, which is a continuation-in-part of application No. 15/058,408, filed on Mar. 2, 2016, now Pat. No. 10,037,171.

(60) Provisional application No. 62/154,886, filed on Apr. 30, 2015.

(51) **Int. Cl.**

G06F 11/07 (2006.01)
G06F 3/06 (2006.01)
G06F 16/00 (2019.01)
G06F 11/10 (2006.01)
G06F 16/182 (2019.01)
G06F 16/23 (2019.01)
G06N 3/063 (2006.01)
G06N 3/08 (2006.01)
G06N 3/06 (2006.01)

(52) **U.S. Cl.**

CPC **G06F 11/079** (2013.01); **G06F 11/0727** (2013.01); **G06F 11/0751** (2013.01); **G06F 11/0769** (2013.01); **G06F 11/1092** (2013.01); **G06F 16/00** (2019.01); **G06F 16/182** (2019.01); **G06F 16/2365** (2019.01); **G06N 3/0454** (2013.01); **G06N 3/0635** (2013.01); **G06N 3/08** (2013.01); **G06F 2211/1028** (2013.01); **G06N 3/06** (2013.01)

(56) **References Cited**

U.S. PATENT DOCUMENTS

5,485,474 A 1/1996 Rabin
5,774,643 A 6/1998 Lubbers et al.
5,802,364 A 9/1998 Senator et al.
5,809,285 A 9/1998 Hilland
5,890,156 A 3/1999 Rekieta et al.
5,987,622 A 11/1999 Lo Verso et al.
5,991,414 A 11/1999 Garay et al.
6,012,159 A 1/2000 Fischer et al.
6,058,454 A 5/2000 Gerlach et al.
6,128,277 A 10/2000 Bruck et al.
6,175,571 B1 1/2001 Haddock et al.
6,192,472 B1 2/2001 Garay et al.
6,256,688 B1 7/2001 Suetaka et al.
6,272,658 B1 8/2001 Steele et al.
6,301,604 B1 10/2001 Nojima
6,356,949 B1 3/2002 Katsandres et al.
6,366,995 B1 4/2002 Vilkov et al.
6,374,336 B1 4/2002 Peters et al.
6,415,373 B1 7/2002 Peters et al.
6,418,539 B1 7/2002 Walker
6,449,688 B1 9/2002 Peters et al.
6,567,948 B2 5/2003 Steele et al.
6,571,282 B1 5/2003 Bowman-Amuah
6,609,223 B1 8/2003 Wolfgang
6,718,361 B1 4/2004 Basani et al.
6,760,808 B2 7/2004 Peters et al.
6,785,768 B2 8/2004 Peters et al.
6,785,783 B2 8/2004 Buckland
6,826,711 B2 11/2004 Moulton et al.
6,879,596 B1 4/2005 Dooply
7,003,688 B1 2/2006 Pittelkow et al.
7,024,451 B2 4/2006 Jorgenson
7,024,609 B2 4/2006 Wolfgang et al.
7,080,101 B1 7/2006 Watson et al.
7,103,824 B2 9/2006 Halford
7,103,915 B2 9/2006 Redlich et al.
7,111,115 B2 9/2006 Peters et al.
7,140,044 B2 11/2006 Redlich et al.
7,146,644 B2 12/2006 Redlich et al.
7,171,493 B2 1/2007 Shu et al.

7,222,133 B1 5/2007 Raipurkar et al.
7,240,236 B2 7/2007 Cutts et al.
7,272,613 B2 9/2007 Sim et al.
7,636,724 B2 12/2009 de la Torre et al.
10,037,171 B2* 7/2018 Baptist G06F 3/067
10,157,094 B2* 12/2018 Cocagne G06N 3/0454
10,748,055 B2* 8/2020 Cocagne G06F 3/064
2002/0062422 A1 5/2002 Butterworth et al.
2002/0166079 A1 11/2002 Ulrich et al.
2003/0018927 A1 1/2003 Gadir et al.
2003/0037261 A1 2/2003 Meffert et al.
2003/0065617 A1 4/2003 Watkins et al.
2003/0084020 A1 5/2003 Shu
2004/0024963 A1 2/2004 Talagala et al.
2004/0122917 A1 6/2004 Menon et al.
2004/0215998 A1 10/2004 Buxton et al.
2004/0228493 A1 11/2004 Ma
2005/0100022 A1 5/2005 Ramprashad
2005/0114594 A1 5/2005 Corbett et al.
2005/0125593 A1 6/2005 Karpoff et al.
2005/0131993 A1 6/2005 Fatula
2005/0132070 A1 6/2005 Redlich et al.
2005/0144382 A1 6/2005 Schmisser
2005/0229069 A1 10/2005 Hassner et al.
2006/0047907 A1 3/2006 Shiga et al.
2006/0136448 A1 6/2006 Cialini et al.
2006/0156059 A1 7/2006 Kitamura
2006/0224603 A1 10/2006 Correll
2007/0079081 A1 4/2007 Gladwin et al.
2007/0079082 A1 4/2007 Gladwin et al.
2007/0079083 A1 4/2007 Gladwin et al.
2007/0088970 A1 4/2007 Buxton et al.
2007/0174192 A1 7/2007 Gladwin et al.
2007/0214285 A1 9/2007 Au et al.
2007/0234110 A1 10/2007 Soran et al.
2007/0283167 A1 12/2007 Venters et al.
2009/0094251 A1 4/2009 Gladwin et al.
2009/0094318 A1 4/2009 Gladwin et al.
2010/0023524 A1 1/2010 Gladwin et al.
2010/0169415 A1 7/2010 Leggette et al.
2011/0225204 A1 3/2011 Liguori

OTHER PUBLICATIONS

Harrison; Lightweight Directory Access Protocol (LDAP): Authentication Methods and Security Mechanisms; IETF Network Working Group; RFC 4513; Jun. 2006; pp. 1-32.
Kubiatowicz, et al.; OceanStore: An Architecture for Global-Scale Persistent Storage; Proceedings of the Ninth International Conference on Architectural Support for Programming Languages and Operating Systems (ASPLOS 2000); Nov. 2000; pp. 1-12.
Legg; Lightweight Directory Access Protocol (LDAP): Syntaxes and Matching Rules; IETF Network Working Group; RFC 4517; Jun. 2006; pp. 1-50.
Plank, T1; Erasure Codes for Storage Applications; FAST2005, 4th Usenix Conference on File Storage Technologies; Dec. 13-16, 2005; pp. 1-74.
Rabin; Efficient Dispersal of Information for Security, Load Balancing, and Fault Tolerance; Journal of the Association for Computer Machinery; vol. 36, No. 2; Apr. 1989; pp. 335-348.
Satran, et al.; Internet Small Computer Systems Interface (iSCSI); IETF Network Working Group; RFC 3720; Apr. 2004; pp. 1-257.
Sciberras; Lightweight Directory Access Protocol (LDAP): Schema for User Applications; IETF Network Working Group; RFC 4519; Jun. 2006; pp. 1-33.
Sermersheim; Lightweight Directory Access Protocol (LDAP): The Protocol; IETF Network Working Group; RFC 4511; Jun. 2006; pp. 1-68.
Shamir; How to Share a Secret; Communications of the ACM; vol. 22, No. 11; Nov. 1979; pp. 612-613.
Smith; Lightweight Directory Access Protocol (LDAP): String Representation of Search Filters; IETF Network Working Group; RFC 4515; Jun. 2006; pp. 1-12.
Smith; Lightweight Directory Access Protocol (LDAP): Uniform Resource Locator; IETF Network Working Group; RFC 4516; Jun. 2006; pp. 1-15.

(56)

References Cited

OTHER PUBLICATIONS

Wildi; Java iSCSi Initiator; Master Thesis; Department of Computer and Information Science, University of Konstanz; Feb. 2007; 60 pgs.

Xin, et al.; Evaluation of Distributed Recovery in Large-Scale Storage Systems; 13th IEEE International Symposium on High Performance Distributed Computing; Jun. 2004; pp. 172-181.

Zeilenga; Lightweight Directory Access Protocol (LDAP): Technical Specification Road Map; IETF Network Working Group; RFC 4510; Jun. 2006; pp. 1-8.

Zeilenga; Lightweight Directory Access Protocol (LDAP): Directory Information Models; IETF Network Working Group; RFC 4512; Jun. 2006; pp. 1-49.

Zeilenga; Lightweight Directory Access Protocol (LDAP): Internationalized String Preparation; IETF Network Working Group; RFC 4518; Jun. 2006; pp. 1-14.

Zeilenga; Lightweight Directory Access Protocol (LDAP): String Representation of Distinguished Names; IETF Network Working Group; RFC 4514; Jun. 2006; pp. 1-15.

* cited by examiner

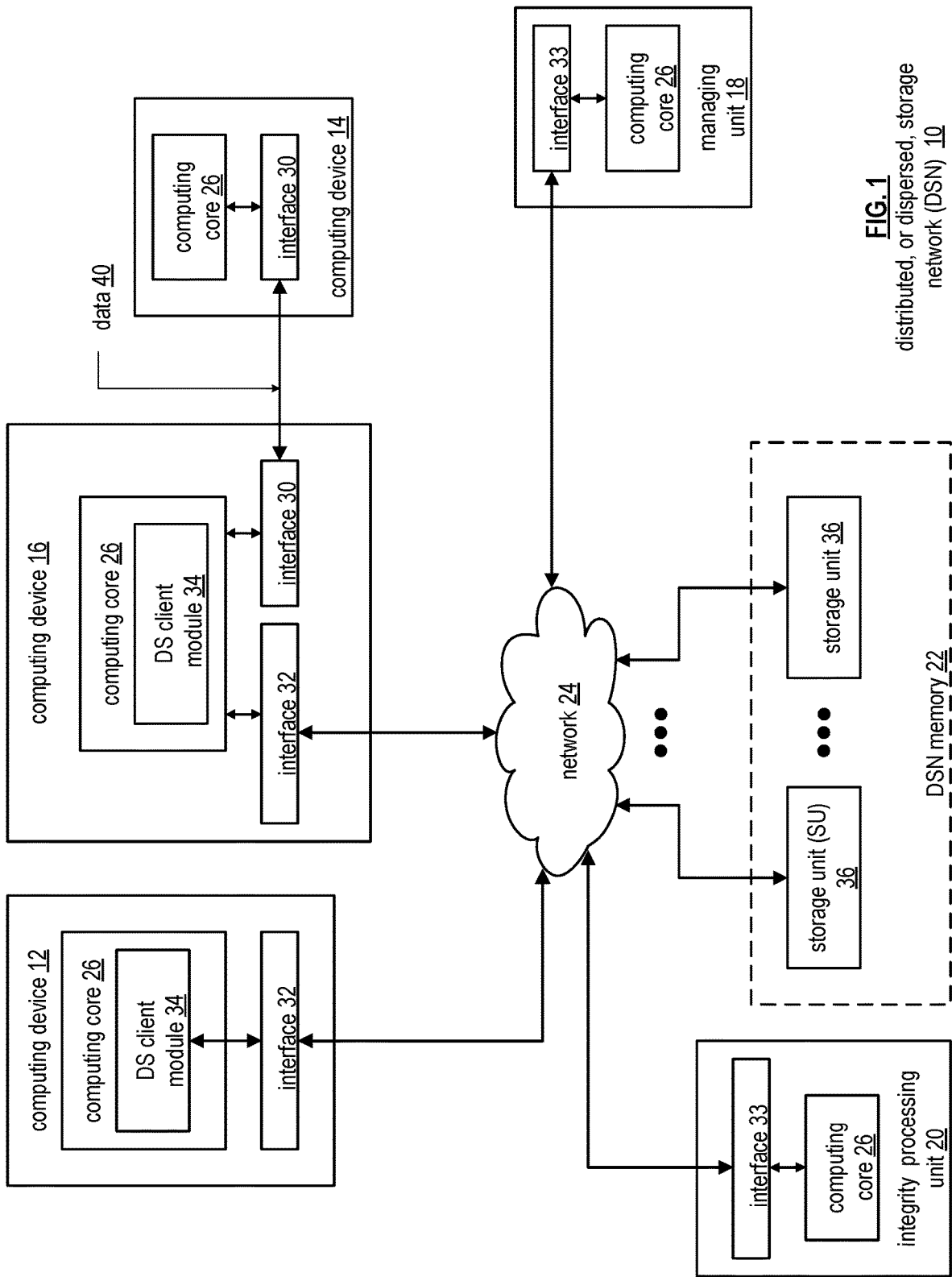

FIG. 1
distributed, or dispersed, storage
network (DSN) 10

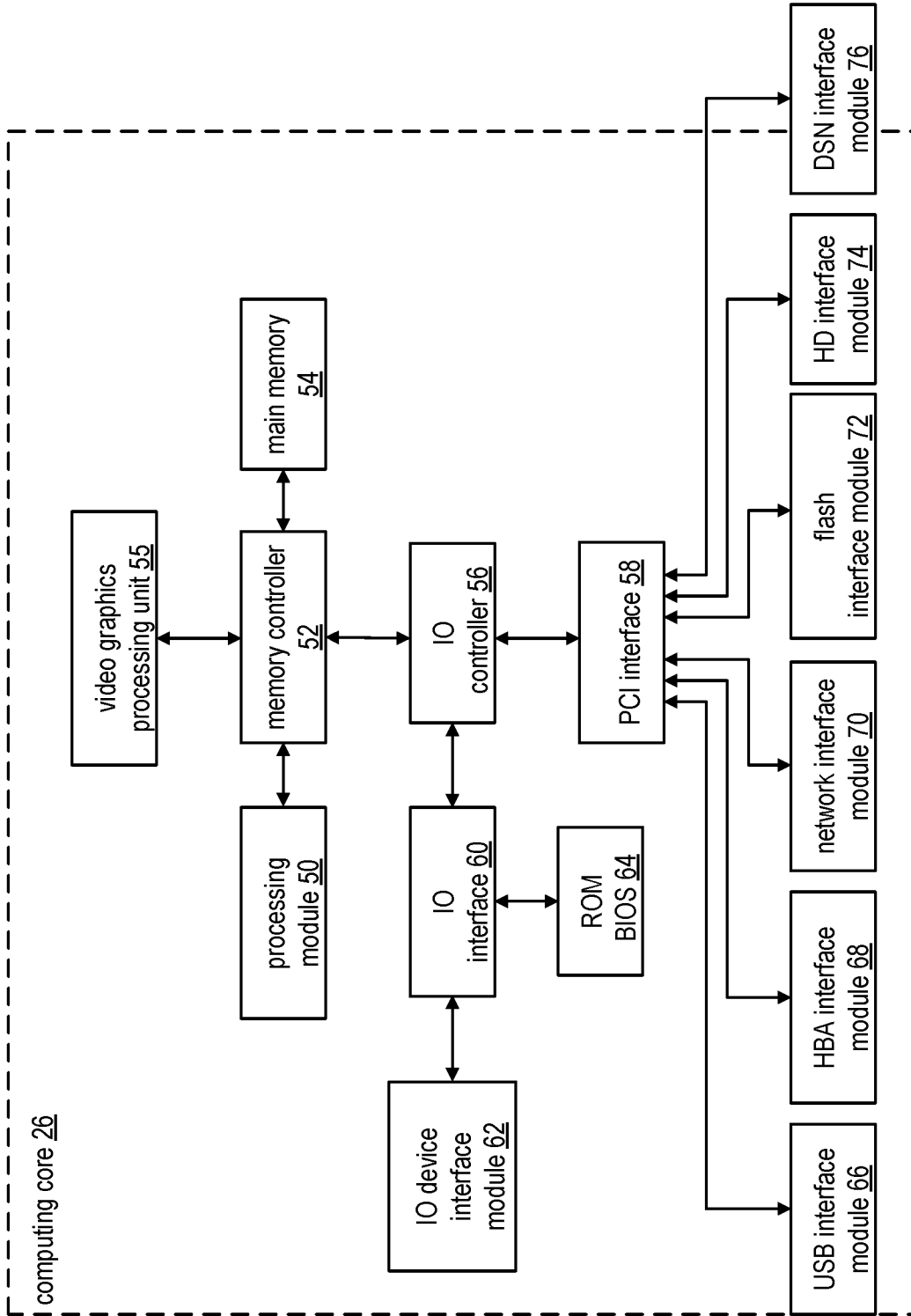
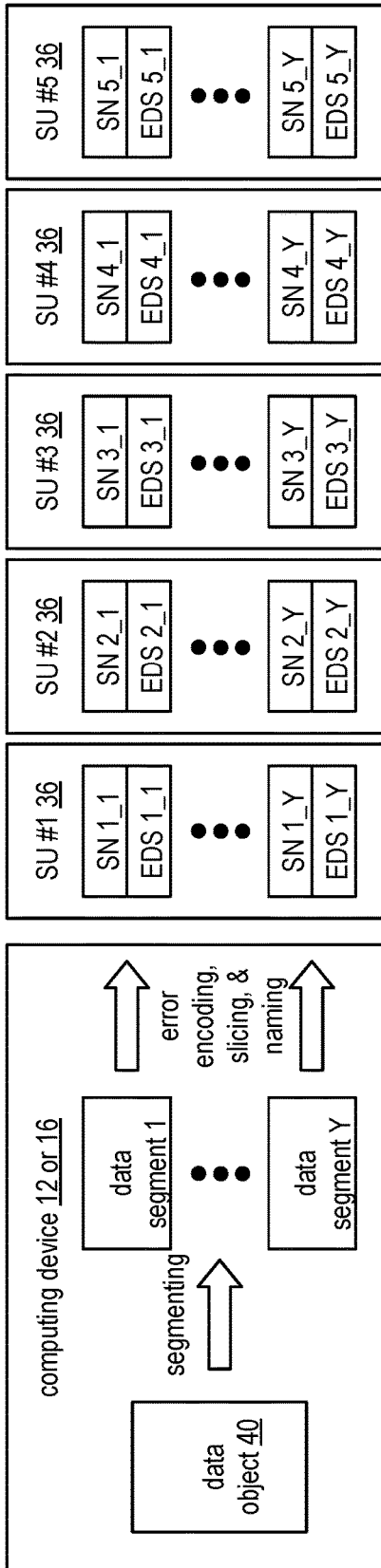

FIG. 2



SN = slice name
EDS = encoded data slice

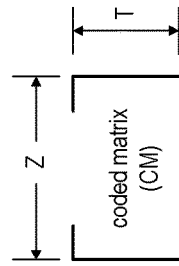

FIG. 3

FIG. 4

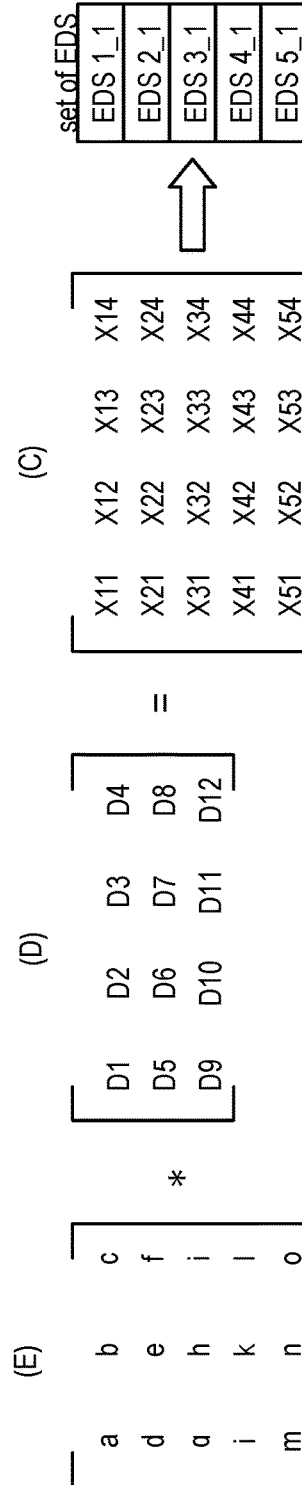

FIG. 5

slice name 80			
pillar #	data segment #	vault ID	data object ID
			rev. info

FIG. 6

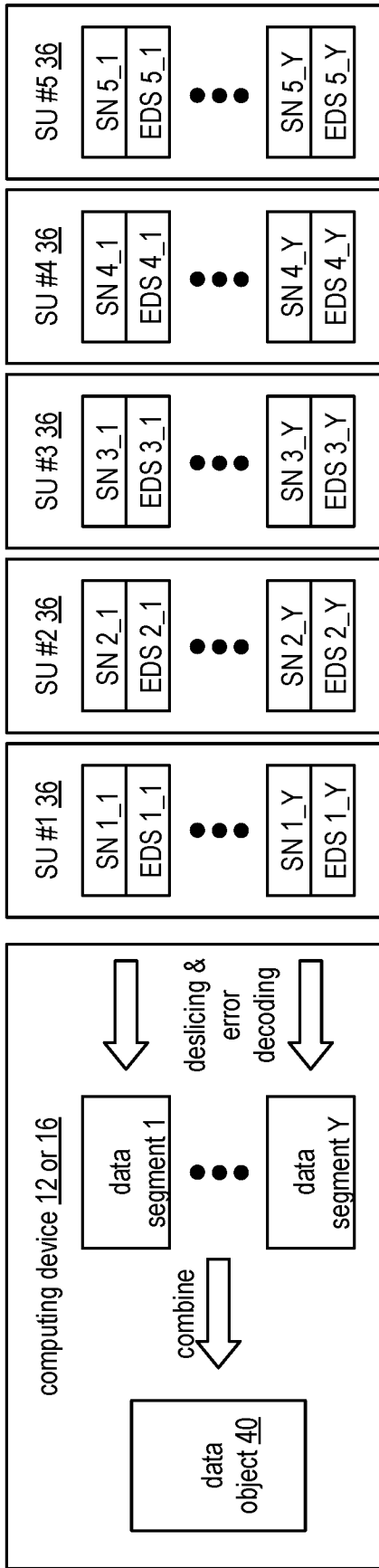

FIG. 7

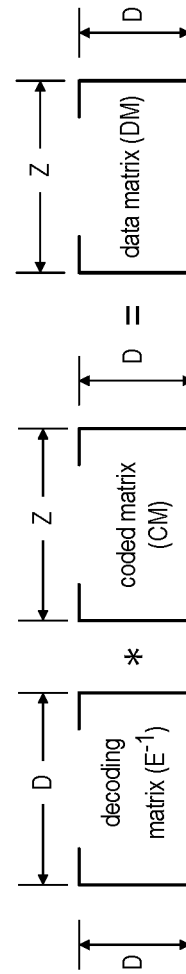

FIG. 8

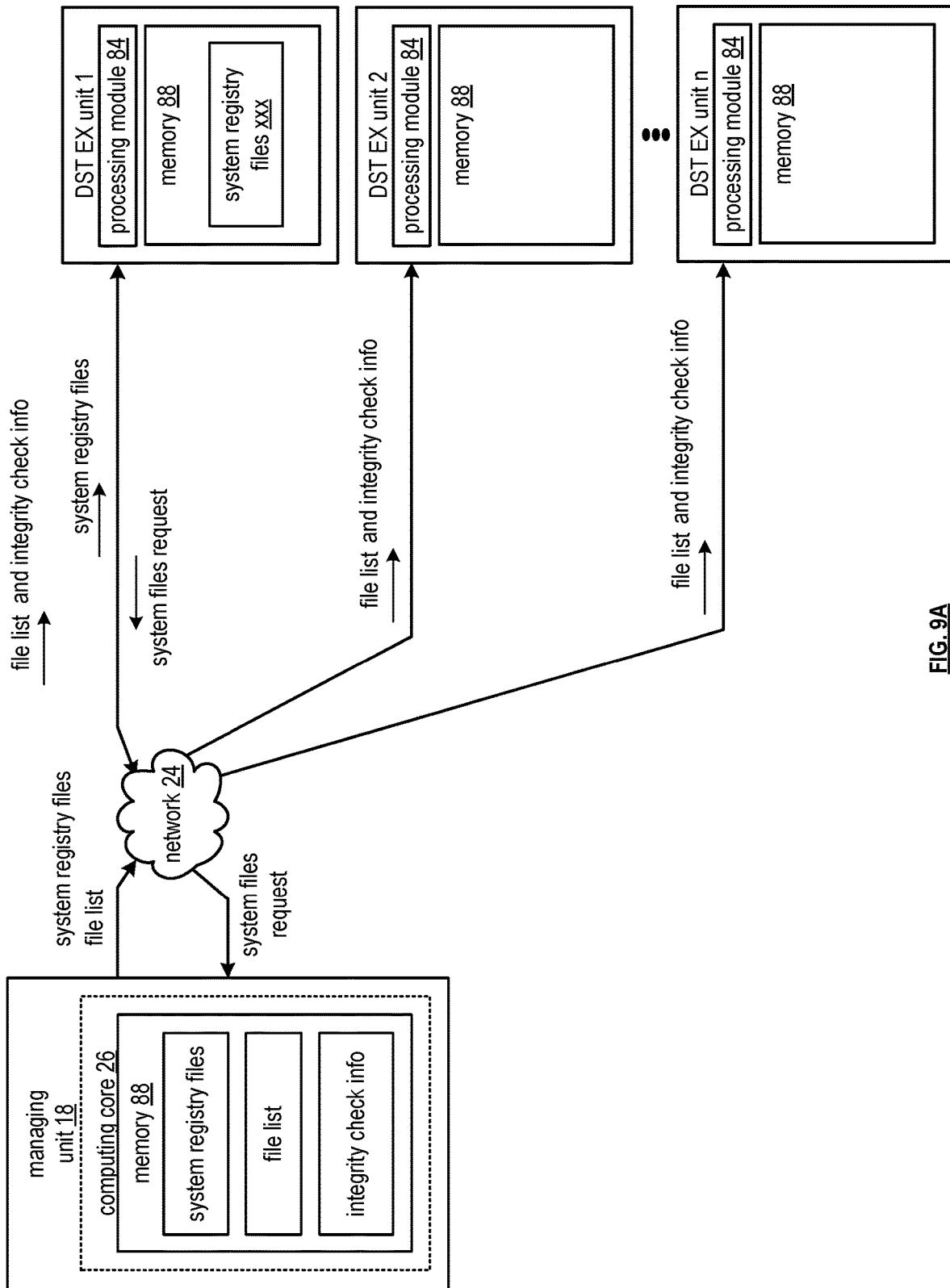

FIG. 9A

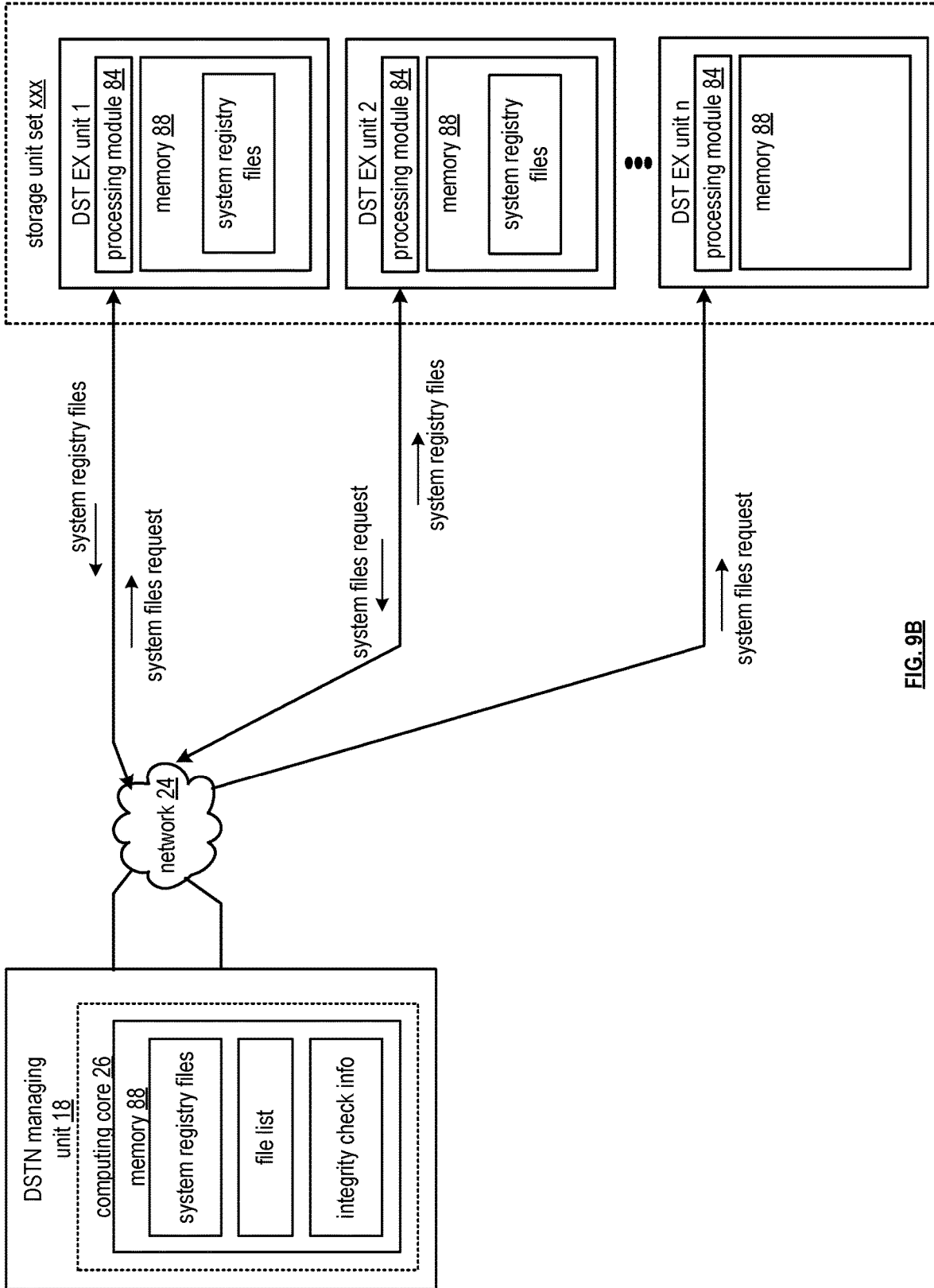

FIG. 9B

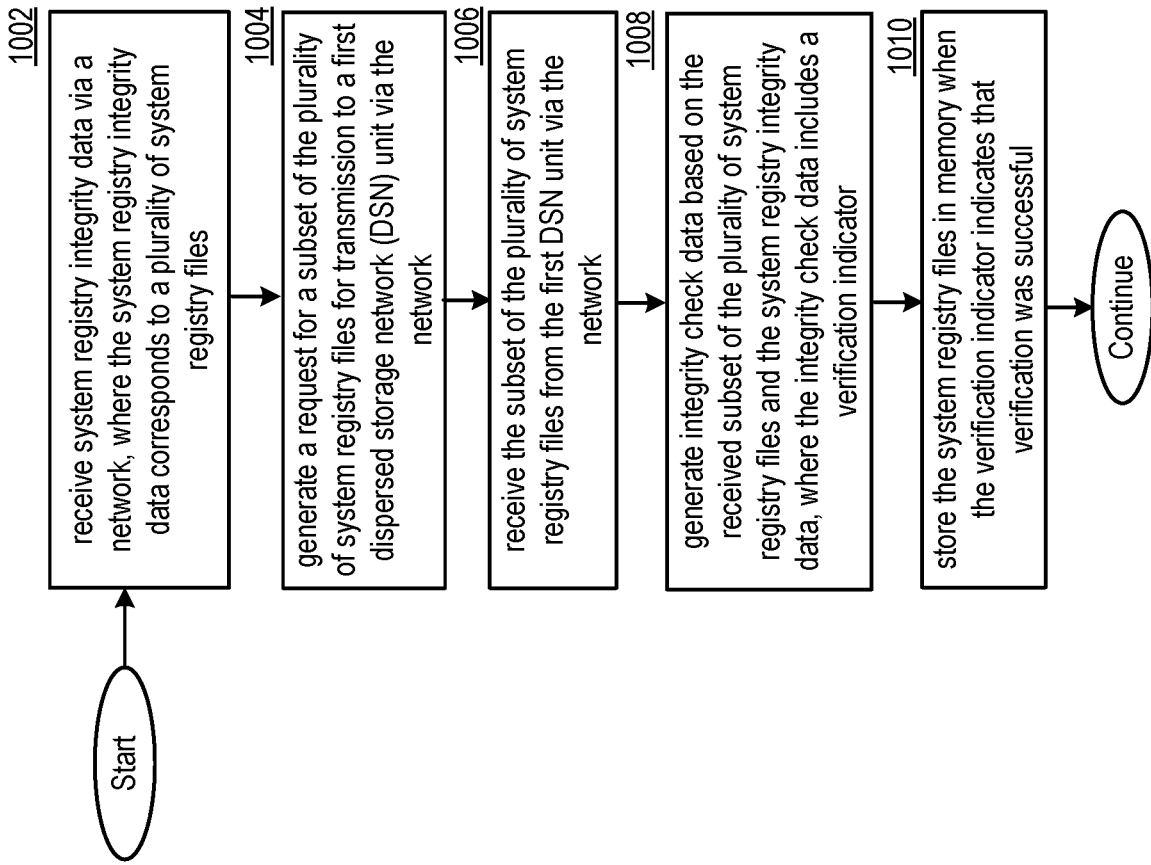

FIG. 10

VERIFYING SYSTEM REGISTRY FILES IN A STORAGE NETWORK

CROSS-REFERENCE TO RELATED APPLICATIONS

The present U.S. Utility Patent application claims priority pursuant to 35 U.S.C. § 120 as a continuation of U.S. Utility application Ser. No. 16/145,481, entitled “VALIDATING SYSTEM REGISTRY FILES IN A DISPERSED STORAGE NETWORK”, filed Sep. 28, 2018, which is a continuation of U.S. Utility application Ser. No. 15/262,808, entitled “VALIDATING SYSTEM REGISTRY FILES IN A DISPERSED STORAGE NETWORK”, filed Sep. 12, 2016, issued as U.S. Pat. No. 10,157,094 on Dec. 18, 2018, which is a continuation-in-part of U.S. Utility application Ser. No. 15/058,408, entitled “ACCESSING COMMON DATA IN A DISPERSED STORAGE NETWORK”, filed Mar. 2, 2016, issued as U.S. Pat. No. 10,037,171 on Jul. 31, 2018, which claims priority pursuant to 35 U.S.C. § 119(e) to U.S. Provisional Application No. 62/154,886, entitled “BALANCING MAINTENANCE AND ACCESS TASKS IN A DISPERSED STORAGE NETWORK”, filed Apr. 30, 2015, all of which are hereby incorporated herein by reference in their entirety and made part of the present U.S. Utility Patent Application for all purposes.

STATEMENT REGARDING FEDERALLY SPONSORED RESEARCH OR DEVELOPMENT

Not applicable.

INCORPORATION-BY-REFERENCE OF MATERIAL SUBMITTED ON A COMPACT DISC

Not applicable.

BACKGROUND OF THE INVENTION

Technical Field of the Invention

This invention relates generally to computer networks and more particularly to dispersing error encoded data.

Description of Related Art

Computing devices are known to communicate data, process data, and/or store data. Such computing devices range from wireless smart phones, laptops, tablets, personal computers (PC), work stations, and video game devices, to data centers that support millions of web searches, stock trades, or on-line purchases every day. In general, a computing device includes a central processing unit (CPU), a memory system, user input/output interfaces, peripheral device interfaces, and an interconnecting bus structure.

As is further known, a computer may effectively extend its CPU by using “cloud computing” to perform one or more computing functions (e.g., a service, an application, an algorithm, an arithmetic logic function, etc.) on behalf of the computer. Further, for large services, applications, and/or functions, cloud computing may be performed by multiple cloud computing resources in a distributed manner to improve the response time for completion of the service, application, and/or function. For example, Hadoop is an

open source software framework that supports distributed applications enabling application execution by thousands of computers.

In addition to cloud computing, a computer may use “cloud storage” as part of its memory system. As is known, cloud storage enables a user, via its computer, to store files, applications, etc. on an Internet storage system. The Internet storage system may include a RAID (redundant array of independent disks) system and/or a dispersed storage system that uses an error correction scheme to encode data for storage.

BRIEF DESCRIPTION OF THE SEVERAL VIEWS OF THE DRAWING(S)

FIG. 1 is a schematic block diagram of an embodiment of a dispersed or distributed storage network (DSN) in accordance with the present invention;

FIG. 2 is a schematic block diagram of an embodiment of a computing core in accordance with the present invention;

FIG. 3 is a schematic block diagram of an example of dispersed storage error encoding of data in accordance with the present invention;

FIG. 4 is a schematic block diagram of a generic example of an error encoding function in accordance with the present invention;

FIG. 5 is a schematic block diagram of a specific example of an error encoding function in accordance with the present invention;

FIG. 6 is a schematic block diagram of an example of a slice name of an encoded data slice (EDS) in accordance with the present invention;

FIG. 7 is a schematic block diagram of an example of dispersed storage error decoding of data in accordance with the present invention;

FIG. 8 is a schematic block diagram of a generic example of an error decoding function in accordance with the present invention;

FIG. 9A is a schematic block diagram of an embodiment of a dispersed or distributed storage network (DSN) in accordance with the present invention;

FIG. 9B is a schematic block diagram of an embodiment of a dispersed or distributed storage network (DSN) in accordance with the present invention; and

FIG. 10 is a logic diagram of an example of a method of validating system registry files in accordance with the present invention.

DETAILED DESCRIPTION OF THE INVENTION

FIG. 1 is a schematic block diagram of an embodiment of a dispersed, or distributed, storage network (DSN) 10 that includes a plurality of computing devices 12-16, a managing unit 18, an integrity processing unit 20, and a DSN memory 22. The components of the DSN 10 are coupled to a network 24, which may include one or more wireless and/or wire lined communication systems; one or more non-public intranet systems and/or public internet systems; and/or one or more local area networks (LAN) and/or wide area networks (WAN).

The DSN memory 22 includes a plurality of storage units 36 that may be located at geographically different sites (e.g., one in Chicago, one in Milwaukee, etc.), at a common site, or a combination thereof. For example, if the DSN memory 22 includes eight storage units 36, each storage unit is located at a different site. As another example, if the DSN

memory **22** includes eight storage units **36**, all eight storage units are located at the same site. As yet another example, if the DSN memory **22** includes eight storage units **36**, a first pair of storage units are at a first common site, a second pair of storage units are at a second common site, a third pair of storage units are at a third common site, and a fourth pair of storage units are at a fourth common site. Note that a DSN memory **22** may include more or less than eight storage units **36**. Further note that each storage unit **36** includes a computing core (as shown in FIG. 2, or components thereof) and a plurality of memory devices for storing dispersed error encoded data.

In various embodiments, each of the storage units operates as a distributed storage and task (DST) execution unit, and is operable to store dispersed error encoded data and/or to execute, in a distributed manner, one or more tasks on data. The tasks may be a simple function (e.g., a mathematical function, a logic function, an identify function, a find function, a search engine function, a replace function, etc.), a complex function (e.g., compression, human and/or computer language translation, text-to-voice conversion, voice-to-text conversion, etc.), multiple simple and/or complex functions, one or more algorithms, one or more applications, etc. Hereafter, a storage unit may be interchangeably referred to as a dispersed storage and task (DST) execution unit and a set of storage units may be interchangeably referred to as a set of DST execution units.

Each of the computing devices **12-16**, the managing unit **18**, and the integrity processing unit **20** include a computing core **26**, which includes network interfaces **30-33**. Computing devices **12-16** may each be a portable computing device and/or a fixed computing device. A portable computing device may be a social networking device, a gaming device, a cell phone, a smart phone, a digital assistant, a digital music player, a digital video player, a laptop computer, a handheld computer, a tablet, a video game controller, and/or any other portable device that includes a computing core. A fixed computing device may be a computer (PC), a computer server, a cable set-top box, a satellite receiver, a television set, a printer, a fax machine, home entertainment equipment, a video game console, and/or any type of home or office computing equipment. Note that each managing unit **18** and the integrity processing unit **20** may be separate computing devices, may be a common computing device, and/or may be integrated into one or more of the computing devices **12-16** and/or into one or more of the storage units **36**. In various embodiments, computing devices **12-16** can include user devices and/or can be utilized by a requesting entity generating access requests, which can include requests to read or write data to storage units in the DSN.

Each interface **30, 32**, and **33** includes software and hardware to support one or more communication links via the network **24** indirectly and/or directly. For example, interface **30** supports a communication link (e.g., wired, wireless, direct, via a LAN, via the network **24**, etc.) between computing devices **14** and **16**. As another example, interface **32** supports communication links (e.g., a wired connection, a wireless connection, a LAN connection, and/or any other type of connection to/from the network **24**) between computing devices **12 & 16** and the DSN memory **22**. As yet another example, interface **33** supports a communication link for each of the managing unit **18** and the integrity processing unit **20** to the network **24**.

Computing devices **12** and **16** include a dispersed storage (DS) client module **34**, which enables the computing device to dispersed storage error encode and decode data as subsequently described with reference to one or more of FIGS.

3-8. In this example embodiment, computing device **16** functions as a dispersed storage processing agent for computing device **14**. In this role, computing device **16** dispersed storage error encodes and decodes data on behalf of computing device **14**. With the use of dispersed storage error encoding and decoding, the DSN **10** is tolerant of a significant number of storage unit failures (the number of failures is based on parameters of the dispersed storage error encoding function) without loss of data and without the need for a redundant or backup copies of the data. Further, the DSN **10** stores data for an indefinite period of time without data loss and in a secure manner (e.g., the system is very resistant to unauthorized attempts at accessing the data).

In operation, the managing unit **18** performs DS management services. For example, the managing unit **18** establishes distributed data storage parameters (e.g., vault creation, distributed storage parameters, security parameters, billing information, user profile information, etc.) for computing devices **12-14** individually or as part of a group of user devices. As a specific example, the managing unit **18** coordinates creation of a vault (e.g., a virtual memory block associated with a portion of an overall namespace of the DSN) within the DSN memory **22** for a user device, a group of devices, or for public access and establishes per vault dispersed storage (DS) error encoding parameters for a vault. The managing unit **18** facilitates storage of DS error encoding parameters for each vault by updating registry information of the DSN **10**, where the registry information may be stored in the DSN memory **22**, a computing device **12-16**, the managing unit **18**, and/or the integrity processing unit **20**.

The DSN managing unit **18** creates and stores user profile information (e.g., an access control list (ACL)) in local memory and/or within memory of the DSN memory **22**. The user profile information includes authentication information, permissions, and/or the security parameters. The security parameters may include encryption/decryption scheme, one or more encryption keys, key generation scheme, and/or data encoding/decoding scheme.

The DSN managing unit **18** creates billing information for a particular user, a user group, a vault access, public vault access, etc. For instance, the DSN managing unit **18** tracks the number of times a user accesses a non-public vault and/or public vaults, which can be used to generate a per-access billing information. In another instance, the DSN managing unit **18** tracks the amount of data stored and/or retrieved by a user device and/or a user group, which can be used to generate a per-data-amount billing information.

As another example, the managing unit **18** performs network operations, network administration, and/or network maintenance. Network operations includes authenticating user data allocation requests (e.g., read and/or write requests), managing creation of vaults, establishing authentication credentials for user devices, adding/deleting components (e.g., user devices, storage units, and/or computing devices with a DS client module **34**) to/from the DSN **10**, and/or establishing authentication credentials for the storage units **36**. Network administration includes monitoring devices and/or units for failures, maintaining vault information, determining device and/or unit activation status, determining device and/or unit loading, and/or determining any other system level operation that affects the performance level of the DSN **10**. Network maintenance includes facilitating replacing, upgrading, repairing, and/or expanding a device and/or unit of the DSN **10**.

The integrity processing unit **20** performs rebuilding of 'bad' or missing encoded data slices. At a high level, the

integrity processing unit **20** performs rebuilding by periodically attempting to retrieve/list encoded data slices, and/or slice names of the encoded data slices, from the DSN memory **22**. For retrieved encoded slices, they are checked for errors due to data corruption, outdated version, etc. If a slice includes an error, it is flagged as a 'bad' slice. For encoded data slices that were not received and/or not listed, they are flagged as missing slices. Bad and/or missing slices are subsequently rebuilt using other retrieved encoded data slices that are deemed to be good slices to produce rebuilt slices. The rebuilt slices are stored in the DSN memory **22**.

FIG. 2 is a schematic block diagram of an embodiment of a computing core **26** that includes a processing module **50**, a memory controller **52**, main memory **54**, a video graphics processing unit **55**, an input/output (IO) controller **56**, a peripheral component interconnect (PCI) interface **58**, an IO interface module **60**, at least one IO device interface module **62**, a read only memory (ROM) basic input output system (BIOS) **64**, and one or more memory interface modules. The one or more memory interface module(s) includes one or more of a universal serial bus (USB) interface module **66**, a host bus adapter (HBA) interface module **68**, a network interface module **70**, a flash interface module **72**, a hard drive interface module **74**, and a DSN interface module **76**.

The DSN interface module **76** functions to mimic a conventional operating system (OS) file system interface (e.g., network file system (NFS), flash file system (FFS), disk file system (DFS), file transfer protocol (FTP), web-based distributed authoring and versioning (WebDAV), etc.) and/or a block memory interface (e.g., small computer system interface (SCSI), internet small computer system interface (iSCSI), etc.). The DSN interface module **76** and/or the network interface module **70** may function as one or more of the interface **30-33** of FIG. 1. Note that the IO device interface module **62** and/or the memory interface modules **66-76** may be collectively or individually referred to as IO ports.

FIG. 3 is a schematic block diagram of an example of dispersed storage error encoding of data. When a computing device **12** or **16** has data to store it disperse storage error encodes the data in accordance with a dispersed storage error encoding process based on dispersed storage error encoding parameters. Here, the computing device stores data object **40**, which can include a file (e.g., text, video, audio, etc.), or other data arrangement. The dispersed storage error encoding parameters include an encoding function (e.g., information dispersal algorithm (IDA), Reed-Solomon, Cauchy Reed-Solomon, systematic encoding, non-systematic encoding, on-line codes, etc.), a data segmenting protocol (e.g., data segment size, fixed, variable, etc.), and per data segment encoding values. The per data segment encoding values include a total, or pillar width, number (T) of encoded data slices per encoding of a data segment i.e., in a set of encoded data slices; a decode threshold number (D) of encoded data slices of a set of encoded data slices that are needed to recover the data segment; a read threshold number (R) of encoded data slices to indicate a number of encoded data slices per set to be read from storage for decoding of the data segment; and/or a write threshold number (W) to indicate a number of encoded data slices per set that must be accurately stored before the encoded data segment is deemed to have been properly stored. The dispersed storage error encoding parameters may further include slicing information (e.g., the number of encoded data slices that will be created for each data segment) and/or slice security information (e.g., per encoded data slice encryption, compression, integrity checksum, etc.).

In the present example, Cauchy Reed-Solomon has been selected as the encoding function (a generic example is shown in FIG. 4 and a specific example is shown in FIG. 5); the data segmenting protocol is to divide the data object into fixed sized data segments; and the per data segment encoding values include: a pillar width of 5, a decode threshold of 3, a read threshold of 4, and a write threshold of 4. In accordance with the data segmenting protocol, the computing device **12** or **16** divides data object **40** into a plurality of fixed sized data segments (e.g., 1 through Y of a fixed size in range of Kilo-bytes to Tera-bytes or more). The number of data segments created is dependent of the size of the data and the data segmenting protocol.

The computing device **12** or **16** then disperse storage error encodes a data segment using the selected encoding function (e.g., Cauchy Reed-Solomon) to produce a set of encoded data slices. FIG. 4 illustrates a generic Cauchy Reed-Solomon encoding function, which includes an encoding matrix (EM), a data matrix (DM), and a coded matrix (CM). The size of the encoding matrix (EM) is dependent on the pillar width number (T) and the decode threshold number (D) of selected per data segment encoding values. To produce the data matrix (DM), the data segment is divided into a plurality of data blocks and the data blocks are arranged into D number of rows with Z data blocks per row. Note that Z is a function of the number of data blocks created from the data segment and the decode threshold number (D). The coded matrix is produced by matrix multiplying the data matrix by the encoding matrix.

FIG. 5 illustrates a specific example of Cauchy Reed-Solomon encoding with a pillar number (T) of five and decode threshold number of three. In this example, a first data segment is divided into twelve data blocks (D1-D12). The coded matrix includes five rows of coded data blocks, where the first row of X11-X14 corresponds to a first encoded data slice (EDS 1_1), the second row of X21-X24 corresponds to a second encoded data slice (EDS 2_1), the third row of X31-X34 corresponds to a third encoded data slice (EDS 3_1), the fourth row of X41-X44 corresponds to a fourth encoded data slice (EDS 4_1), and the fifth row of X51-X54 corresponds to a fifth encoded data slice (EDS 5_1). Note that the second number of the EDS designation corresponds to the data segment number.

Returning to the discussion of FIG. 3, the computing device also creates a slice name (SN) for each encoded data slice (EDS) in the set of encoded data slices. A typical format for a slice name **80** is shown in FIG. 6. As shown, the slice name (SN) **80** includes a pillar number of the encoded data slice (e.g., one of 1-T), a data segment number (e.g., one of 1-Y), a vault identifier (ID), a data object identifier (ID), and may further include revision level information of the encoded data slices. The slice name functions as, at least part of, a DSN address for the encoded data slice for storage and retrieval from the DSN memory **22**.

As a result of encoding, the computing device **12** or **16** produces a plurality of sets of encoded data slices, which are provided with their respective slice names to the storage units for storage. As shown, the first set of encoded data slices includes EDS 1_1 through EDS 5_1 and the first set of slice names includes SN 1_1 through SN 5_1 and the last set of encoded data slices includes EDS 1_Y through EDS 5_Y and the last set of slice names includes SN 1_Y through SN 5_Y.

FIG. 7 is a schematic block diagram of an example of dispersed storage error decoding of a data object that was dispersed storage error encoded and stored in the example of FIG. 4. In this example, the computing device **12** or **16**

retrieves from the storage units at least the decode threshold number of encoded data slices per data segment. As a specific example, the computing device retrieves a read threshold number of encoded data slices.

To recover a data segment from a decode threshold number of encoded data slices, the computing device uses a decoding function as shown in FIG. 8. As shown, the decoding function is essentially an inverse of the encoding function of FIG. 4. The coded matrix includes a decode threshold number of rows (e.g., three in this example) and the decoding matrix is an inversion of the encoding matrix that includes the corresponding rows of the coded matrix. For example, if the coded matrix includes rows 1, 2, and 4, the encoding matrix is reduced to rows 1, 2, and 4, and then inverted to produce the decoding matrix.

FIG. 9A illustrates steps of an example of operation of secure distribution of one or more files amongst one or more computing devices that have already established trust. The managing unit 18 can issue a file list and integrity check information to devices of the DSN, where the file list includes an identifier list of system registry files for distribution and where the integrity check information includes an integrity value, such as a cryptographic hash value, for each file and/or all system registry files associated with the file list. The issuing includes obtaining the file list, generating the integrity check information over corresponding system registry files associated with the file list, and sending, via the network 24, the file list and integrity check information to the devices of the DSN. Such DSN units can include, for example, storage units 36, integrity processing unit 20, and/or computing devices 12-16. In FIG. 9A, the DSN units include dispersed storage and task (DST) execution units 1-n, which can be implemented by utilizing storage units 36 of FIG. 1, for example, operating as a distributed storage and task (DST) execution unit as described previously, operable to store dispersed error encoded data and/or to execute, in a distributed manner, one or more tasks on data.

Having received the file list, a DSN unit can issue a system files status request to one or more other DSN units affiliated with the DSN unit when the DSN unit requires the system registry files associated with the file list (e.g., the system registry files are absent from the DSN unit). Issuing a system files request includes selecting the one or more other DSN units generating the files based on the file list, and sending the files request to the selected one or more other DSN units. The selecting can be based on proximity with respect to the DSN unit (e.g., selecting DSN units that are closest), an expected network loading level, a DST execution unit performance level, a network performance level, and/or DSN configuration information. For example, the processing module 84 of the DST execution unit 1 issues, via the network 24, a system files status request to the other DST execution units and to the managing unit 18 when the other DST execution units in the managing unit 18 are located within a proximity threshold of the DST execution unit 1.

Having issued the system files status request, the DSN unit, within a response timeframe, can select a transmitting DSN unit based on a corresponding files response. For example, the DST execution unit 1 selects the managing unit 18 when receiving a favorable files response (e.g., indicating that the system registry files are available) from the managing unit 18 and receiving one or more unfavorable files responses (e.g., indicating that the system registry files are not available) from the other DST execution units.

Having selected the transmitting DSN unit, the DSN unit can send a system files transmission request to the selected transmitting DSN unit. For example, the DSTN execution

unit 1 generates and sends, via the network 24, the system files transmission request to the DSTN managing unit 18. In response to the system files transmission request, the DSN unit receives the system registry files for storage. For example, the DST execution unit 1 receives, via the network 24, the system registry files from the DSTN managing unit 18.

Having received the system registry files, the DSN unit can validate the received system registry files based on one or more of the integrity check information and the file list. The validating includes indicating valid when a calculated integrity check value compares favorably with a received integrity check value for a portion of the system registry files. When the system registry files are validated, the DSN unit facilitates local storage of the received system registry files. For example, as shown in FIG. 9A, the processing module 84 of the DST execution unit 1 can store the validated received system registry files in the memory 88 of the DST execution unit 1. The processing module 84 and memory 88 can be implemented utilizing the computing core of FIG. 2, for example, by specifically utilizing the processing module 50 and main memory 54 of the computing core. This protocol is secure against a DSN unit receiving an invalid file, assuming that no one can determine a different file that has the same hash value as one of the common files. This is an assumption for algorithms classified as cryptographically secure hash functions. In various embodiments, the DSN unit can send a status transmission to other DSN units indicating that these system registry files are available. In various embodiments, the DSN unit can send a verification error notification, for example for transmission to the monitoring unit 18, when validation was unsuccessful.

FIG. 9B illustrates further steps of the example of operation of the distributing of the one or more files, where a second DSN unit issues a files request to one or more other DSN units affiliated with the second DSN unit. For example, the processing module 84 of the DST execution unit 2 can issue, via the network 24, another system files status request to the remaining DST execution units of the set of DST execution units. Having sent the system files status request, within the response timeframe, the second DSN unit can select another transmitting DSN unit that is storing the system registry files based on a corresponding files response. For example, the DST execution unit 2 selects the DST execution unit 1 based on a favorable system files response from the DST execution unit 1 indicating that the system registry files are stored in the memory 88 of the DST execution unit 1.

Having selected this second transmitting DSN unit, the second DSN unit sends another system files transmission request to this selected transmitting DSN unit. For example, the DST execution unit 2 can send, via the network 24, this system files transmission request to the DST execution unit 1 to initiate transmission of the system registry files. Having sent this system files transmission request, the second DSN unit can receive the system registry files for storage. Having received the system registry files, the second DSN unit can validate the received system registry files based on the integrity check information and/or the file list. When validated, the second DSN unit can store the validated received system registry files in a local memory associated with the second DSN unit. For example, the processing module 84 of the DST execution unit 2 stores the validated received system registry files in the memory 88 of the DST execution unit 2.

In various embodiments, a processing system of a dispersed storage and task (DST) execution unit includes at least one processor and a memory that stores operational instructions, that when executed by the at least one processor cause the processing system to receive system registry integrity data via a network, where the system registry integrity data corresponds to a plurality of system registry files. A request for a subset of the plurality of system registry files for is generated for transmission to a first dispersed storage network (DSN) unit via the network. The subset of the plurality of system registry files are received from the first DSN unit via the network. Integrity check data is generated based on the received subset of the plurality of system registry files and the system registry integrity data, where the integrity check data includes a verification indicator. The system registry files are stored in memory when the verification indicator indicates that verification was successful.

In various embodiments, the system registry integrity data includes a plurality of file identifiers corresponding to the plurality of system registry files and a plurality of integrity values corresponding to the plurality of system registry files. In various embodiments, the plurality of integrity values are cryptographic hash values corresponding to the plurality of system registry files. In various embodiments, the integrity check data is generated by calculating at least one integrity check value by performing a function on the received subset of the plurality of system registry files, and comparing the at least one integrity check value to a corresponding at least one of the plurality of integrity values of the system registry integrity data. The verification indicator indicates that verification was successful when the at least one integrity check value compares favorably to the corresponding at least one of the plurality of integrity values.

In various embodiments, a system files status request is generated for transmission to a set of DSN units via the network, where the system files status request indicates the subset of the plurality of system registry files. A plurality of system file statuses are received via the network from at least one of the set of DSN units. The first DSN unit is selected from the set of DSN units based on the plurality of system file statuses. In various embodiments, the set of DSN units are selected from a plurality of DSN units further based on proximity to the DST execution unit, an expected network loading level, a DST processing unit performance level, a network performance level, and/or DSN configuration information. In various embodiments, the first DSN unit is selected from the set of DSN units in response to a one of the plurality of system file statuses corresponding to the first DSN unit indicating that the subset of the plurality of system registry files are available. In various embodiments, a second DSN is selected from the set of DSN units, where a first one of the plurality of system file statuses corresponding to the first DSN unit and a second one of the plurality of system file statuses corresponding to the second DSN unit indicate that a first portion of the subset are available from the first DSN unit and a second portion of the subset are available from the second DSN unit. The first portion and the second portion collectively include all of the system registry files of the subset. A request for the second portion of the subset is generated for transmission via the network to the second DSN, and the second portion of the subset is received in response via the network.

In various embodiments, a verification error notification is generated for transmission via the network when the verification indicator indicates that verification was unsuccessful. In various embodiments, a system file status update is

generated for transmission via the network to a plurality of DSN units when the verification indicator indicates that verification was successful. The system file status update indicates that the subset of the plurality of system registry files are available.

FIG. 10 is a flowchart illustrating an example of validating system registry files. In particular, a method is presented for use in association with one or more functions and features described in conjunction with FIGS. 1-9, for execution by a dispersed storage and task (DST) execution unit that includes a processor or via another processing system of a dispersed storage network that includes at least one processor and memory that stores instruction that configure the processor or processors to perform the steps described below. Step 1002 includes receiving system registry integrity data via a network, where the system registry integrity data corresponds to a plurality of system registry files. Step 1004 includes generating a request for a subset of the plurality of system registry files for transmission to a first dispersed storage network (DSN) unit via the network. Step 1006 includes receiving the subset of the plurality of system registry files from the first DSN unit via the network. Step 1008 includes generating integrity check data based on the received subset of the plurality of system registry files and the system registry integrity data, where the integrity check data includes a verification indicator. Step 1010 includes storing the system registry files in memory when the verification indicator indicates that verification was successful.

In various embodiments, the system registry integrity data includes a plurality of file identifiers corresponding to the plurality of system registry files and a plurality of integrity values corresponding to the plurality of system registry files. In various embodiments, the plurality of integrity values are cryptographic hash values corresponding to the plurality of system registry files. In various embodiments, the integrity check data is generated by calculating at least one integrity check value by performing a function on the received subset of the plurality of system registry files, and comparing the at least one integrity check value to a corresponding at least one of the plurality of integrity values of the system registry integrity data. The verification indicator indicates that verification was successful when the at least one integrity check value compares favorably to the corresponding at least one of the plurality of integrity values.

In various embodiments, a system files status request is generated for transmission to a set of DSN units via the network, where the system files status request indicates the subset of the plurality of system registry files. A plurality of system file statuses are received via the network from at least one of the set of DSN units. The first DSN unit is selected from the set of DSN units based on the plurality of system file statuses. In various embodiments, the set of DSN units are selected from a plurality of DSN units further based on proximity to the DST execution unit, an expected network loading level, a DST processing unit performance level, a network performance level, and/or DSN configuration information. In various embodiments, the first DSN unit is selected from the set of DSN units in response to a one of the plurality of system file statuses corresponding to the first DSN unit indicating that the subset of the plurality of system registry files are available. In various embodiments, a second DSN is selected from the set of DSN units, where a first one of the plurality of system file statuses corresponding to the first DSN unit and a second one of the plurality of system file statuses corresponding to the second DSN unit indicate that a first portion of the subset are available from the first DSN unit and a second portion of the subset are available

from the second DSN unit. The first portion and the second portion collectively include all of the system registry files of the subset. A request for the second portion of the subset is generated for transmission via the network to the second DSN, and the second portion of the subset is received in response via the network.

In various embodiments, a verification error notification is generated for transmission via the network when the verification indicator indicates that verification was unsuccessful. In various embodiments, a system file status update is generated for transmission via the network to a plurality of DSN units when the verification indicator indicates that verification was successful. The system file status update indicates that the subset of the plurality of system registry files are available.

In various embodiments, a non-transitory computer readable storage medium includes at least one memory section that stores operational instructions that, when executed by a processing system of a dispersed storage network (DSN) that includes a processor and a memory, causes the processing system to receive system registry integrity data via a network, where the system registry integrity data corresponds to a plurality of system registry files. A request for a subset of the plurality of system registry files for is generated for transmission to a first dispersed storage network (DSN) unit via the network. The subset of the plurality of system registry files are received from the first DSN unit via the network. Integrity check data is generated based on the received subset of the plurality of system registry files and the system registry integrity data, where the integrity check data includes a verification indicator. The system registry files are stored in memory when the verification indicator indicates that verification was successful.

It is noted that terminologies as may be used herein such as bit stream, stream, signal sequence, etc. (or their equivalents) have been used interchangeably to describe digital information whose content corresponds to any of a number of desired types (e.g., data, video, speech, audio, etc. any of which may generally be referred to as 'data').

As may be used herein, the terms "substantially" and "approximately" provides an industry-accepted tolerance for its corresponding term and/or relativity between items. Such an industry-accepted tolerance ranges from less than one percent to fifty percent and corresponds to, but is not limited to, component values, integrated circuit process variations, temperature variations, rise and fall times, and/or thermal noise. Such relativity between items ranges from a difference of a few percent to magnitude differences. As may also be used herein, the term(s) "configured to", "operably coupled to", "coupled to", and/or "coupling" includes direct coupling between items and/or indirect coupling between items via an intervening item (e.g., an item includes, but is not limited to, a component, an element, a circuit, and/or a module) where, for an example of indirect coupling, the intervening item does not modify the information of a signal but may adjust its current level, voltage level, and/or power level. As may further be used herein, inferred coupling (i.e., where one element is coupled to another element by inference) includes direct and indirect coupling between two items in the same manner as "coupled to". As may even further be used herein, the term "configured to", "operable to", "coupled to", or "operably coupled to" indicates that an item includes one or more of power connections, input(s), output(s), etc., to perform, when activated, one or more its corresponding functions and may further include inferred coupling to one or more other items. As may still further be used herein, the term "associated with", includes direct

and/or indirect coupling of separate items and/or one item being embedded within another item.

As may be used herein, the term "compares favorably", indicates that a comparison between two or more items, signals, etc., provides a desired relationship. For example, when the desired relationship is that signal 1 has a greater magnitude than signal 2, a favorable comparison may be achieved when the magnitude of signal 1 is greater than that of signal 2 or when the magnitude of signal 2 is less than that of signal 1. As may be used herein, the term "compares unfavorably", indicates that a comparison between two or more items, signals, etc., fails to provide the desired relationship.

As may also be used herein, the terms "processing module", "processing circuit", "processor", and/or "processing unit" may be a single processing device or a plurality of processing devices. Such a processing device may be a microprocessor, micro-controller, digital signal processor, microcomputer, central processing unit, field programmable gate array, programmable logic device, state machine, logic circuitry, analog circuitry, digital circuitry, and/or any device that manipulates signals (analog and/or digital) based on hard coding of the circuitry and/or operational instructions. The processing module, module, processing circuit, and/or processing unit may be, or further include, memory and/or an integrated memory element, which may be a single memory device, a plurality of memory devices, and/or embedded circuitry of another processing module, module, processing circuit, and/or processing unit. Such a memory device may be a read-only memory, random access memory, volatile memory, non-volatile memory, static memory, dynamic memory, flash memory, cache memory, and/or any device that stores digital information. Note that if the processing module, module, processing circuit, and/or processing unit includes more than one processing device, the processing devices may be centrally located (e.g., directly coupled together via a wired and/or wireless bus structure) or may be distributedly located (e.g., cloud computing via indirect coupling via a local area network and/or a wide area network). Further note that if the processing module, module, processing circuit, and/or processing unit implements one or more of its functions via a state machine, analog circuitry, digital circuitry, and/or logic circuitry, the memory and/or memory element storing the corresponding operational instructions may be embedded within, or external to, the circuitry comprising the state machine, analog circuitry, digital circuitry, and/or logic circuitry. Still further note that, the memory element may store, and the processing module, module, processing circuit, and/or processing unit executes, hard coded and/or operational instructions corresponding to at least some of the steps and/or functions illustrated in one or more of the Figures. Such a memory device or memory element can be included in an article of manufacture.

One or more embodiments have been described above with the aid of method steps illustrating the performance of specified functions and relationships thereof. The boundaries and sequence of these functional building blocks and method steps have been arbitrarily defined herein for convenience of description. Alternate boundaries and sequences can be defined so long as the specified functions and relationships are appropriately performed. Any such alternate boundaries or sequences are thus within the scope and spirit of the claims. Further, the boundaries of these functional building blocks have been arbitrarily defined for convenience of description. Alternate boundaries could be defined as long as the certain significant functions are appropriately performed. Similarly, flow diagram blocks

may also have been arbitrarily defined herein to illustrate certain significant functionality.

To the extent used, the flow diagram block boundaries and sequence could have been defined otherwise and still perform the certain significant functionality. Such alternate definitions of both functional building blocks and flow diagram blocks and sequences are thus within the scope and spirit of the claims. One of average skill in the art will also recognize that the functional building blocks, and other illustrative blocks, modules and components herein, can be implemented as illustrated or by discrete components, application specific integrated circuits, processors executing appropriate software and the like or any combination thereof.

In addition, a flow diagram may include a “start” and/or “continue” indication. The “start” and “continue” indications reflect that the steps presented can optionally be incorporated in or otherwise used in conjunction with other routines. In this context, “start” indicates the beginning of the first step presented and may be preceded by other activities not specifically shown. Further, the “continue” indication reflects that the steps presented may be performed multiple times and/or may be succeeded by other activities not specifically shown. Further, while a flow diagram indicates a particular ordering of steps, other orderings are likewise possible provided that the principles of causality are maintained.

The one or more embodiments are used herein to illustrate one or more aspects, one or more features, one or more concepts, and/or one or more examples. A physical embodiment of an apparatus, an article of manufacture, a machine, and/or of a process may include one or more of the aspects, features, concepts, examples, etc. described with reference to one or more of the embodiments discussed herein. Further, from figure to figure, the embodiments may incorporate the same or similarly named functions, steps, modules, etc. that may use the same or different reference numbers and, as such, the functions, steps, modules, etc. may be the same or similar functions, steps, modules, etc. or different ones.

Unless specifically stated to the contra, signals to, from, and/or between elements in a figure of any of the figures presented herein may be analog or digital, continuous time or discrete time, and single-ended or differential. For instance, if a signal path is shown as a single-ended path, it also represents a differential signal path. Similarly, if a signal path is shown as a differential path, it also represents a single-ended signal path. While one or more particular architectures are described herein, other architectures can likewise be implemented that use one or more data buses not expressly shown, direct connectivity between elements, and/or indirect coupling between other elements as recognized by one of average skill in the art.

The term “module” is used in the description of one or more of the embodiments. A module implements one or more functions via a device such as a processor or other processing device or other hardware that may include or operate in association with a memory that stores operational instructions. A module may operate independently and/or in conjunction with software and/or firmware. As also used herein, a module may contain one or more sub-modules, each of which may be one or more modules.

As may further be used herein, a computer readable memory includes one or more memory elements. A memory element may be a separate memory device, multiple memory devices, or a set of memory locations within a memory device. Such a memory device may be a read-only memory, random access memory, volatile memory, non-

volatile memory, static memory, dynamic memory, flash memory, cache memory, and/or any device that stores digital information. The memory device may be in a form a solid state memory, a hard drive memory, cloud memory, thumb drive, server memory, computing device memory, and/or other physical medium for storing digital information.

While particular combinations of various functions and features of the one or more embodiments have been expressly described herein, other combinations of these features and functions are likewise possible. The present disclosure is not limited by the particular examples disclosed herein and expressly incorporates these other combinations.

What is claimed is:

1. A method for execution by a processing system that includes a processor, the method comprises:
 - generating a request for a plurality of system registry files; receiving the plurality of system registry files via a network;
 - generating integrity check data based on the plurality of system registry files and system registry integrity data corresponding to the plurality of system registry files, wherein the integrity check data includes a verification indicator; and
 - storing the system registry files in memory when the verification indicator indicates that verification was successful.
2. The method of claim 1, wherein the system registry integrity data includes a plurality of file identifiers corresponding to the plurality of system registry files and a plurality of integrity values corresponding to the plurality of system registry files.
3. The method of claim 2, wherein the plurality of integrity values are cryptographic hash values corresponding to the plurality of system registry files.
4. The method of claim 2, wherein the integrity check data is generated by calculating at least one integrity check value by performing a function on the plurality of system registry files, and comparing the at least one integrity check value to a corresponding at least one of the plurality of integrity values of the system registry integrity data, and wherein the verification indicator indicates that verification was successful when the at least one integrity check value compares favorably to the corresponding at least one of the plurality of integrity values.
5. The method of claim 1, further comprising:
 - generating a system files status request for transmission to a set of storage units via the network, wherein the system files status request indicates the plurality of system registry files;
 - receiving a plurality of system file statuses via the network from at least one of the set of storage units;
 - selecting a first storage unit from the set of storage units based on the plurality of system file statuses; and
 - transmitting the request for the plurality of system registry files to the first storage unit.
6. The method of claim 5, further comprising:
 - selecting the set of storage units from a plurality of storage units further based on at least one of: proximity to the processing system, an expected network loading level, a processing system performance level, a network performance level, or storage network configuration information.
7. The method of claim 5, wherein the first storage unit is selected from the set of storage units in response to a one of the plurality of system file statuses corresponding to the first storage unit indicating that the plurality of system registry files are available.

15

8. The method of claim 5, further comprising:
 selecting a second storage unit from the set of storage units, wherein a first one of the plurality of system file statuses corresponding to the first storage unit and a second one of the plurality of system file statuses corresponding to the second storage unit indicate that a first portion of the plurality of system registry files are available from the first storage unit and a second portion of the plurality of system registry files are available from the second storage unit, and wherein the first portion and the second portion collectively include all of the system registry files of the plurality of system registry files; and
 generating a request for the second portion of the plurality of system registry files for transmission via the network to the second storage unit and receiving the second portion of the plurality of system registry files in response via the network.
9. The method of claim 1, further comprising:
 generating a verification error notification for transmission via the network when the verification indicator indicates that verification was unsuccessful.
10. The method of claim 1, further comprising:
 generating a system file status update for transmission via the network to a plurality of storage units when the verification indicator indicates that verification was successful, wherein the system file status update indicates that the plurality of system registry files are available.
11. A processing system of a dispersed storage and task (DST) execution unit comprises:
 at least one processor;
 a memory that stores operational instructions, that when executed by the at least one processor cause the processing system to:
 generate a request for a plurality of system registry files;
 receive the plurality of system registry files via a network;
 generate integrity check data based on the plurality of system registry files and system registry integrity data corresponding to the plurality of system registry files, wherein the integrity check data includes a verification indicator; and
 store the system registry files in memory when the verification indicator indicates that verification was successful.
12. The processing system of claim 11, wherein the system registry integrity data includes a plurality of file identifiers corresponding to the plurality of system registry files and a plurality of integrity values corresponding to the plurality of system registry files.
13. The processing system of claim 12, wherein the plurality of integrity values are cryptographic hash values corresponding to the plurality of system registry files.
14. The processing system of claim 12, wherein the integrity check data is generated by calculating at least one integrity check value by performing a function on the plurality of system registry files, and comparing the at least one integrity check value to a corresponding at least one of the plurality of integrity values of the system registry integrity data, and wherein the verification indicator indicates that verification was successful when the at least one integrity check value compares favorably to the corresponding at least one of the plurality of integrity values.

16

15. The processing system of claim 11, wherein the operational instructions, when executed by the at least one processor, further cause the processing system to:
 generating a system files status request for transmission to a set of storage units via the network, wherein the system files status request indicates the plurality of system registry files;
 receiving a plurality of system file statuses via the network from at least one of the set of storage units;
 selecting a first storage unit from the set of storage units based on the plurality of system file statuses; and
 transmitting the request for the plurality of system registry files to the first storage unit.
16. The processing system of claim 15, wherein the operational instructions, when executed by the at least one processor, further cause the processing system to:
 select the set of storage units from a plurality of storage units further based on at least one of: proximity to the processing system, an expected network loading level, a processing system performance level, a network performance level, or storage network configuration information.
17. The processing system of claim 15, wherein the first storage unit is selected from the set of storage units in response to a one of the plurality of system file statuses corresponding to the first storage unit indicating that the plurality of system registry files are available.
18. The processing system of claim 15, wherein the operational instructions, when executed by the at least one processor, further cause the processing system to:
 select a second storage unit from the set of storage units, wherein a first one of the plurality of system file statuses corresponding to the first storage unit and a second one of the plurality of system file statuses corresponding to the second storage unit indicate that a first portion of the plurality of system registry files are available from the first storage unit and a second portion of the plurality of system registry files are available from the second storage unit, and wherein the first portion and the second portion collectively include all of the system registry files of the plurality of system registry files; and
 generate a request for the second portion of the plurality of system registry files for transmission via the network to the second storage unit and receiving the second portion of the plurality of system registry files in response via the network.
19. The processing system of claim 11, wherein the operational instructions, when executed by the at least one processor, further cause the processing system to:
 generate a verification error notification for transmission via the network when the verification indicator indicates that verification was unsuccessful.
20. A non-transitory computer readable storage medium comprises:
 at least one memory section that stores operational instructions that, when executed by a processing system of a storage network that includes a processor and a memory, causes the processing system to:
 generate a request for a plurality of system registry files;
 receive the plurality of system registry files via a network;
 generate integrity check data based on the plurality of system registry files and system registry integrity

data corresponding to the plurality of system registry files, wherein the integrity check data includes a verification indicator; and
store the system registry files in memory when the verification indicator indicates that verification was 5
successful.

* * * * *