



- (51) International Patent Classification:  
A43C 1/00 (2006.01)
- (21) International Application Number:  
PCT/US2014/013458
- (22) International Filing Date:  
28 January 2014 (28.01.2014)
- (25) Filing Language: English
- (26) Publication Language: English
- (30) Priority Data:  
61/757,692 28 January 2013 (28.01.2013) US
- (71) Applicant: BOA TECHNOLOGY INC. [US/US]; 3459  
Ringsby Court, Suite 300, Denver, Colorado 80216 (US).
- (72) Inventor: NEILEY, Roger T.; 4 N. Vista de la Luna, La-  
guna Beach, California 92651 (US).
- (74) Agent: WEIGHT, Clark F.; c/o Kilpatrick Townsend &  
Stockton LLP, Eighth Floor, Two Embarcadero Center,  
San Francisco, CA 94111 (US).
- (81) Designated States (unless otherwise indicated, for every  
kind of national protection available): AE, AG, AL, AM,  
AO, AT, AU, AZ, BA, BB, BG, BH, BN, BR, BW, BY,  
BZ, CA, CH, CL, CN, CO, CR, CU, CZ, DE, DK, DM,

DO, DZ, EC, EE, EG, ES, FI, GB, GD, GE, GH, GM, GT,  
HN, HR, HU, ID, IL, IN, IR, IS, JP, KE, KG, KN, KP, KR,  
KZ, LA, LC, LK, LR, LS, LT, LU, LY, MA, MD, ME,  
MG, MK, MN, MW, MX, MY, MZ, NA, NG, NI, NO, NZ,  
OM, PA, PE, PG, PH, PL, PT, QA, RO, RS, RU, RW, SA,  
SC, SD, SE, SG, SK, SL, SM, ST, SV, SY, TH, TJ, TM,  
TN, TR, TT, TZ, UA, UG, US, UZ, VC, VN, ZA, ZM,  
ZW.

- (84) Designated States (unless otherwise indicated, for every  
kind of regional protection available): ARIPO (BW, GH,  
GM, KE, LR, LS, MW, MZ, NA, RW, SD, SL, SZ, TZ,  
UG, ZM, ZW), Eurasian (AM, AZ, BY, KG, KZ, RU, TJ,  
TM), European (AL, AT, BE, BG, CH, CY, CZ, DE, DK,  
EE, ES, FI, FR, GB, GR, HR, HU, IE, IS, IT, LT, LU, LV,  
MC, MK, MT, NL, NO, PL, PT, RO, RS, SE, SI, SK, SM,  
TR), OAPI (BF, BJ, CF, CG, CI, CM, GA, GN, GQ, GW,  
KM, ML, MR, NE, SN, TD, TG).

**Published:**

- with international search report (Art. 21(3))
- before the expiration of the time limit for amending the  
claims and to be republished in the event of receipt of  
amendments (Rule 48.2(h))

(54) Title: LACE FIXATION ASSEMBLY AND SYSTEM

102

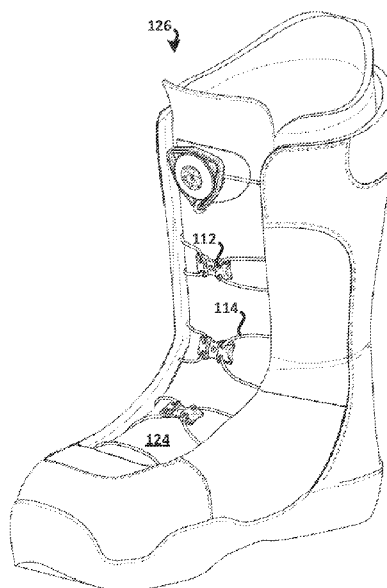

FIG. 8A

(57) Abstract: A lace closure system may include a low friction guide that defines the turning radius and direction of a lace which, though tension, pulls two or more panels toward each other. The lace closure system may include a fixator that defines a slot into which the lace is led, containing multiple engagement surfaces that, when the lace is wrapped into the slot, serve to engage the lace preventing unwanted loosening. The lace closure system may include a ring onto which the lace is attached, to assist in applying manual tension to the lace. The ring may be shaped and sized to removably attach to an outer perimeter of the fixator after excess lace has been wrapped into the slot.



## LACE FIXATION ASSEMBLY AND SYSTEM

### 5 CROSS-REFERENCE TO RELATED APPLICATION

This application claims the benefit of U.S. Provisional Patent Application Number 61/757,692, filed January 28, 2013, entitled LACE FIXATION SYSTEM WITH LOW FRICTION GUIDES, the entirety of which is incorporated by reference for all purposes.

### 10 SUMMARY

Various lace fixation assemblies and systems beneficial to both manufacturers and users. In particular, the lace fixation assemblies and systems of the present disclosure may provide an easy to understand and easy to use means of adjusting and securing the closure of an article of footwear or other item. The lace fixation assemblies and systems of the present disclosure may further allow the use of small-diameter, low-friction lace material that does not require gripping by hand to secure or tighten. The lace fixation assemblies and systems of the present disclosure may further provide a convenient means to store excess lace after tightening while allowing quick and easy release and refastening of the fixation for secondary tension adjustment. The lace fixation assemblies and systems of the present disclosure may further be of a design and material such as plastic or other synthetic material that is economical to produce and to incorporate into existing manufacturing methods.

For example, in a first aspect, a lacing system for tightening an article is disclosed. The lacing system may include or comprise a fixation member coupled to the article, the fixation member having at least one entry aperture and an exit aperture with a lumen extending therebetween, the fixation member also having a spool with a fixation post. In this example, the fixation member may be rigidly fastened to the article. The lumen may include or comprise of a passage, a cavity, a tube structure, or the like. Further, the spool may include or comprise of a flanged cylinder whereby an element may be wound around or to the post. Other embodiments are possible.

30 The lacing system may further include or comprise a tension member having an intermediate portion slidably disposed within the lumen of the fixation member such that a proximal portion of the tension member is positioned on a proximal side of the fixation member and a distal portion of the tension member is positioned on a distal side of the fixation member and such that a length of the proximal portion and a length of the distal

portion is adjustable via sliding of the tension member within the lumen. In this example, the tension member may include or comprise a lace or lacing that has a particular diameter. The tension member may generally be laced to the fixation member, and a length of the tension member protruding or exiting from the fixation member may be adjusted as desired. Other  
5 embodiments are possible.

The lacing system may further include or comprise a plurality of guide members coupled to the article on the proximal side of the fixation member to guide the proximal portion of the tension member along the article to the fixation member. In this example, the tension member may generally be laced to each of the plurality of guide members. Other  
10 embodiments are possible. The lacing system may further include or comprise a tensioning component coupled to the distal portion of the tension member to effect sliding of the tension member within the lumen and thereby tighten the article by adjusting the length of the proximal portion of the tension member, and to maintain a tightness of the article by winding of the tension member about the fixation post, wherein the tensioning component is securable  
15 to the spool of the fixation member. In this example, the tension member together with other elements or features of the example lacing system may be used to tighten the article whereby the tension may be stored to the spool. Other embodiments are possible.

Additionally, or alternatively, the fixation member of the lacing system may include a flange shaped complementary to the panel, so that the fixation member may be properly  
20 fitted to the fixation member. Additionally, or alternatively, the lumen of the lacing system may extend between the entry aperture and the exit apertures in an arcuate configuration, so that the lumen may be guided through the fixation member in a gentle manner with minimized frictional resistance. Additionally, or alternatively, the plurality of guide members the lacing system may be configured to direct lacing along the panel of the article with or  
25 without overlap to the at least one lacing entry aperture and through the lacing exit aperture. Such a feature may be selected as desired and may be implementation-specific. Additionally, or alternatively, the tensioning component of the lacing system may be a ring-shaped element that may be snap-fit coupleable to the spool protrusion. Additionally, or alternatively, the spool protrusion and the tensioning component of the lacing system may each comprise a  
30 plurality of traction members that when engaged inhibit rotation of the tensioning component when the tensioning component is secured to the spool protrusion. Such a feature may prevent unwanted or undesired loosening of the tension member when the tensioning component is positioned to the spool protrusion. Other embodiments are possible.

In another aspect, a lacing system for tightening an article is disclosed. The lacing system may include or comprise first plate coupleable to a first panel of the article and defining at least one lacing entry aperture, a lacing exit aperture, and a keyed protrusion that is positioned to a complementary recess of a second plate of the lacing system to form a groove with a lacing fixation post. In this example, the keyed protrusion and complementary recess may facilitate secure coupling of the first plate with the second plate. Other embodiments are possible. The lacing system may further include or comprise a lacing tensioner coupleable to lacing protruding from the lacing exit aperture and to a periphery of the groove so that the lacing tensioner is securable to the groove when lacing protruding from the lacing exit aperture is wound to the lacing fixation post for tightening the article by pulling together a second panel and a third panel of the article. Other embodiments are possible.

Additionally, or alternatively, the first plate of the lacing system may further define a first plurality of ridged flutes extending radially from the keyed protrusion in a spoke pattern, and the second plate further defining a second plurality of ridged flutes extending radially from the recess in the spoke pattern and offset the first plurality of ridged flutes. Such a feature may maintain lacing tension when lacing protruding from the lacing exit aperture is wound to the lacing fixation post for tightening the article. Additionally, or alternatively, the lacing system may include a plurality of lacing guide members coupleable to the first panel to direct lacing along the first panel to the at least one lacing entry aperture and through the lacing exit aperture. Additionally, or alternatively, the lacing system may include a fastener positioned through an aperture of the keyed protrusion and an aperture of the recess to rigidly secure the keyed protrusion to the recess. Other embodiments are possible.

In another aspect, a method for tightening an article using a lacing system is disclosed. The lacing system may include one or more of the features: a fixation member coupled to the article, the fixation member having at least one entry aperture and an exit aperture with a lumen extending therebetween, and also having a spool with a fixation post; a tension member having an intermediate portion slidably disposed within the lumen of the fixation member so that a proximal portion of the tension member is positioned on a proximal side of the fixation member and a distal portion of the tension member is positioned on a distal side of the fixation member; a plurality of guide members coupled to the article on the proximal side of the fixation member to guide the proximal portion of the tension member along/about the article to the fixation member; and a tensioning component coupled to the distal portion of the tension member. Further, the method may include or comprise tensioning

the tension member via the tensioning component to effect sliding of the tension member within the lumen and thereby tighten the article by shortening the length of the proximal portion of the tension member. The method may further include or comprise winding the tension member about the fixation post via the tensioning component to maintain a tightness  
5 of the article, wherein the tensioning component is securable to the spool of the fixation member.

Additionally, or alternatively, the method may include or comprise securing the tensioning component to the spool of the fixation member. Such a feature may allow for storage of the tensioning component when not in use. Additionally, or alternatively, the  
10 method may include or comprise positioning the tension member to the lumen of the fixation member to lace the tension member to the fixation member. Additionally, or alternatively, the method may include or comprise positioning the tension member to the plurality of guide members to lace the tension member to the plurality of guide members with or without overlap of the tension member. Additionally, or alternatively, the method may include or  
15 comprise positioning the tension member to the tensioning component to couple the tension member to the tensioning component. Additionally, or alternatively, the method may include or comprise winding the tension member within a gap about the fixation post that includes a plurality of radially offset ridged flutes to engage and maintain tension to the tension member. Additionally, or alternatively, the method may include or comprise winding excess  
20 length of the tension member within a gap about the fixation post to store the excess length of tension member about the fixation post. Other embodiments are possible.

Although not so limited, an appreciation of the various aspects of the present disclosure along with associated benefits and/or advantages may be gained from the following discussion in connection with the drawings.

25

### DESCRIPTION OF THE DRAWINGS

**FIG. 1** shows a first lace fixation assembly.

**FIG. 2** shows a first plate of the assembly of **FIG. 1**.

**FIG. 3** show a first view of a first and second plate of the assembly of **FIG. 1**.

30

**FIG. 4** shows a second plate of the assembly of **FIG. 1**.

**FIG. 5** show a second view of a first and second plate of the assembly of **FIG. 1**.

**FIG. 6** shows a tensioning component of the assembly of **FIG. 1**.

**FIGS. 7A-C** show various views of a guide member of a first lace fixation system.

**FIGS. 8A-C** show various views of a first lace fixation system.

**FIG. 9** shows a view of another lace fixation system.

**FIGS. 10A-D** show various views of a second lace fixation assembly.

**FIGS. 11A-C** show various exploded views of the assembly of **FIG. 9**.

**FIGS. 12A-C** show multiple embodiments of the assembly of **FIG. 9**.

5 **FIG. 13** shows a first cross-section A-A of the assembly of **FIG. 9**.

**FIG. 14** shows a second cross-section B-B of the assembly of **FIG. 9**.

**FIG. 15** shows a view of still another lace fixation system.

**FIGS. 16A-B** show various views of still another lace fixation system.

**FIG. 17** shows a view of still another lace fixation system.

10 **FIG. 18** shows a view of still another lace fixation system.

**FIGS. 19A-E** show various views of still another lace fixation system.

**FIG. 20** shows a view of still another lace fixation system.

**FIG. 21** shows a view of still another lace fixation system.

**FIG. 22** shows a view of still another lace fixation system.

15 **FIGS. 23A-C** show various views of a third lace fixation assembly.

**FIGS. 24A-B** show various views of a fourth lace fixation assembly.

**FIG. 25** shows various views of a fifth lace fixation assembly.

In the appended figures, similar components and/or features may have the same numerical reference label. Further, various components of the same type may be distinguished by following the reference label by a letter that distinguishes among the similar components and/or features. If only the first numerical reference label is used in the specification, the description is applicable to any one of the similar components and/or features having the same first numerical reference label irrespective of the letter suffix.

## 25 **DETAILED DESCRIPTION**

Different methods for closing or tightening shoes or boots and other flexible or semi-rigid panels have evolved over the years. Conventional laces whether led through metal eyelets, webbing loops, or low friction guides, have stood the test of time and remain popular. Mechanical systems using rotary dials, serrated grip surfaces and other designs may provide alternatives to knot-secured laces. Hook and loop engagements as well as elastic straps may also serve well in some applications. Currently available designs though present certain drawbacks. For example, conventional laces require the tying of a knot to secure the tightened adjustment, which obligates the user to untie the knot before any secondary adjustment can be made, unless or until the knot loosens of its own accord, requiring retying.

Conventional lace systems are also limited to the use of relatively large diameter laces that are comfortable to grip by hand, the opposite desired characteristics for low-profile, efficient and effective closure. Rotary dials and other mechanical systems eliminate the knot problem and can make use of small diameter laces, but tend to be expensive to manufacture, to the point that they can represent up to 50% of the cost of a given pair of footwear. Some knotless fixation systems self-store excess lace while others require excess lace to be gathered and placed into a pocket on the boot, which is an inconvenient and inelegant solution.

Given the harsh environment of daily use, often in climate extremes, mechanical system latching performance may also be problematic, often when a secure closure is needed most. Hook and loop and elastic systems also suffer performance loss in wet and/or freezing conditions, while being limited in the adjustment range and security of their closure. In addition to fixation issues, many lace systems suffer from excessive friction which can prevent the lace from exerting sufficient closure force in the area farthest from the point where tension is applied. This friction can have many causes including the lace material characteristic, the lace turning guides, the sliding of the lace over high friction surfaces, and also the points at which opposing laces cross over one another. In this aspect of lace function, the dilemma becomes one in which the more tension applied to tighten the closure, the more frictional force is created and the more difficult it becomes to obtain the desired closure. The present disclosure addresses these and other issues by providing a non-complex, inexpensive, non-mechanical, low-friction, knotless closure system with self-storage of excess lace.

For instance, referring now collectively to **FIGS. 1-8**, first lace fixation assembly **100** and first lace fixation system **102** are shown in accordance with the present disclosure. In general, first assembly **100** includes first plate **104**, second plate **106**, tensioning component **108**, and fastener **110**. **FIG. 1** for example illustrates these respective components of first assembly **100** in an assembled configuration. First system **102** includes first assembly **100**, guide members **112**, and tension member **114**. **FIG. 8A** for example shows these respective components of first system **102** in an assembled configuration. In the example embodiment, tension member **114** is laced through first plate **104** of first assembly **100** via arcuate slots **116** that guide ends of tension member **114** from entry apertures **118** to exit aperture **120**. **FIG. 2** for example illustrates entry apertures **118** and exit aperture **120**, and **FIG. 3** for example illustrates arcuate slots **116**. Tension member **114** is further laced through guide members **112** via opposing grooves **122** so that tension member **114** does not overlap onto itself when laced thereto. Both first assembly **100**, at least in part, and guide members **112** are coupled to front panel **124** of boot **126**, and tensioning end **128** of tension member **114** is

coupled to tensioning component **108** at notch **130** of tensioning component **108**. **FIGS. 8A-B** for example illustrate coupling of first assembly **100** and guide members **112** to boot **126** as well as tension member **114** to tensioning component **108**.

In practice, tightening of boot **126** is performed or perfected by application of pulling  
5 force to tensioning component **108**, forcing first side panel **132** and second side panel **134** of  
boot **126** together. While maintaining pulling force, tensioning component **108** is used to  
wrap tension member **114** into channel or groove **136** that is formed between first plate **104**  
and second plate **106**. **FIG. 5** for example illustrates groove **136** formed between first plate  
**104** and second plate **106**. Here, initial wrapping of tension member **114** into groove **136**  
10 forces tension member **114** into friction gap **138** that has surfaces along the length of which  
imparts force on tension member **114** when positioned thereto so that tension is generally  
maintained on tension member **114** when pulling force is removed, as discussed further  
below. Further wrapping of tension member **114** into groove **136** forces portions of tension  
member **114** into storage gap **140**. Storage gap **140** within groove **136** is therefore generally  
15 wider than friction gap **138** as storage gap **140** serves a different purpose than friction gap  
**138** in that it is used to store excess length of tension member **114**. Tension member **114** as  
wrapped onto itself though within both friction gap **138** and storage gap **140** imparts force on  
itself when positioned thereto, so that tension is generally maintained on tension member **114**  
when pulling force is removed.

20 Wrapping of tension member **114** into groove **136** proceeds until length of tension  
member **114** protruding from exit aperture **120** is substantially wound into groove **136**.  
Tensioning component **108** is then generally snap-coupled onto first assembly **100** at groove  
**136**. Tensioning component **108** may be decoupled from first assembly **100** by application of  
leverage similar to that applied when opening a bottle having a cap, and may be used to  
25 unwind tension member **114** thereby loosening first side panel **132** and second side panel **134**  
of boot **126**. First side panel **132** and/or second side panel **134** may then be opened to allow  
exit, or tension reapplied to tension member **114** as desired. Such an implementation may be  
beneficial or advantageous in many respects. For example, knotting of tension member **114** is  
not required, excess length of tension member **114** is stored to first assembly **100** without  
30 additional steps, and through the use of tensioning component **108**, there is no need for a user  
to physically touch tension member **114**. Still other benefits and/or advantages are possible as  
well.

Referring now specifically to **FIGS. 1-6**, first lace fixation assembly **100** is shown in  
accordance with the present disclosure. As mentioned above, first assembly **100** includes first



plate **104**, second plate **106**, tensioning component **108**, and fastener **110**. When assembled, axle- or post-like keyed portion **142** formed on protrusion **144** of first plate **104**, as shown for example in **FIG. 2**, is positioned to complementary recess **146** of second plate **106**, as shown for example in **FIG. 4**. Additionally, fastener **110** is positioned to both second plate aperture **148** that is adjacent to recess **146** and first plate aperture **150** that is formed within keyed portion **142** to secure first plate **104** with second plate **106**. In the example embodiment, keyed portion **142** and recess **146** are star-shaped in cross-section. Other embodiments are however possible, and shape of keyed portion **142** and recess **146** may be implementation-specific. Further, as mentioned above, tensioning component **108** is generally snap-fit coupleable to groove **136** that is formed between first plate **104** and second plate **106**. Rotational movement of tensioning component **108** is limited or restricted when positioned to groove **136** by interlock of bumps or ridges **152** formed on both second plate **106** and tensioning component **108**, illustrated for example at **FIG. 4** and at **FIG. 6**.

Friction gap **138** within groove **136** is defined by first ridged flutes **154** that extend in a spoke pattern from keyed portion **142** of first plate **104**, and second ridged flutes **156** that extend in the spoke pattern from recess **146** of second plate **106**. **FIG. 2** for example illustrates first ridged flutes **154**, and **FIG. 4** for example illustrates second ridged flutes **156**. It is contemplated that more or fewer ridged flutes may be utilized in any pattern as desired, and further number and shape of first ridged flutes **154** and second ridged flutes **156** may be implementation-specific. In the example embodiment, when first plate **104** is coupled with second plate **106**, first ridged flutes **154** and second ridged flutes **156** are rotationally offset from each other so as to form a path for tension member **114** similar to that formed by an interdigitated comb structure. In this instance, however, fingers of the comb structure are interdigitally arranged along a circle. In this manner, first ridged flutes **154** and second ridged flutes **156** are configured and arranged to impart force on tension member **114** when tension member **114** is positioned to friction gap **138** within groove **136**, so that tension is generally maintained on tension member **114** when pulling force is removed.

Referring now specifically to **FIGS. 7A-C**, a particular one of guide members **112** is shown in accordance with the present disclosure. As mentioned above, tension member **114** is laced through guide members **112** via opposing grooves **122** so that tension member **114** does not overlap onto itself. In general, grooves **122** positioned on each side of mounting aperture **158** provide a curved low-friction pathway for tension member **114** as it interfaces with panels **124**, **132**, and **134** of boot **126**, similar to arcuate slots **116** of first plate **104** that provide a low-friction pathway for tension member **114** from entry apertures **118** to exit

aperture **120**. Whereas a typical lacing pattern may route laces back and forth between opposing panels, with laces crossing each other at various points along the center line of a particular panel, guide members **112** eliminate lace crossing and resulting friction that which may impede closure. It is contemplated that any number of guide members **112** may be employed to realize desired closure characteristics while maintaining the lowest possible lace system friction.

In the present example, with guide members **112** attached to center portion of front panel **124**, tension member **114** is guided from first side panel **132** through a particular one of guide members **112**, and back to first side panel **132**. Similarly, tension member **114** is guided from second side panel **134** through a particular one of guide members **112**, and back to second side panel **134**. Tension member **114** thus does not overlap onto itself and does not bind, chafe, or create excess friction. It is contemplated that body **160** of guide members **112** may be curved to generally match the shape of front panel **124** or other intermediate panel onto which they are coupled. Further, profile or thickness **162** of guide members **112** may be defined such that tension member **114** is raised above a surface of an intermediate panel to further reduce friction. Various methods may be employed to attach guide members **112** to front panel **124**, such as in a manner that allows guide members **112** to self-align under loads presented by tension member **114**. Further, in order to facilitate injection molding with minimal tooling complexity, in one embodiment the bearing surface of the guide members **112** may be formed by alternating grooves in top and bottom surfaces. This arrangement may sufficiently capture tension member **114**, keeping tension member **114** bearing upon the desired radius surface, while not requiring any sliding elements in the injection mold.

Referring now to **FIG. 9**, another lace fixation system **902** is shown in accordance with the present disclosure. System **902** is similar to first lace fixation system **102** as described above in many respects. For example, system **902** includes first lace fixation assembly **100** of at least **FIG. 1** coupled to front panel **904** of boot **906**. In the example embodiment, however, tension member **908** is laced through guide members **910** so as to overlap or cross itself. Guide members **910** in **FIG. 9** are webbing or fabric strips that are sewn or otherwise coupled to panels of the article. The webbing or fabric strips **910** include loops through which the tension member **908** is inserted. The webbing or fabric strips **910** may be angled or directed to guide the tension member **908** about the article as desired. In practice though, tightening of boot **906** using first assembly **100** may be performed in a manner similar to that described above. Further, **FIG. 9** demonstrates flexibility of first assembly **100** in that tensioning component **108** may be coupled to groove **136** (e.g., see **FIG.**

5) that is formed between first plate **104** and second plate **106** without orientation-specific keying. In other words, tensioning component **108** may be coupled to groove **136** in any particular orientation. For example, **FIG. 8C** illustrates tensioning component **108** positioned to groove **136** so that notch **130** is orientated towards guide members **112**. In contrast, **FIG. 9** illustrates tensioning component **108** positioned to groove **136** so that notch **130** is orientated away from guide members **910**.

Referring now to **FIGS. 10A-16B**, second lace fixation assembly **1000** and second lace fixation system **1002** are shown in accordance with the present disclosure. In general, second assembly **1000** includes plate **1004** and tensioning component **1006**. **FIG. 10B** for example illustrates these respective components of second assembly **1000** in an assembled configuration. Second system **1002** includes second assembly **1000**, guide members **1008**, and tension member **1010**. **FIG. 15** for example illustrates these respective components of second system **1002** in an assembled configuration. In the example embodiment, tension member **1010** is laced through plate **1004** of second assembly **1000** via plate apertures **1011** that guide tension member **1010** through plate **1004**, and further is laced through guide members **1008** so that tension member **1010** overlaps onto itself. **FIG. 12C** for example illustrates plate apertures **1011**, and **FIG. 15** and **FIG. 16A** for example illustrate lacing of tension member **1010** through guide members **1008** that are coupled to boot **1014**, and lacing of tension member **1010** through plate **1004**, respectively. Other embodiments though are possible. For example, it is contemplated that guide members **112** as discussed above may be used in place of guide members **1008**.

Both second assembly **1000**, at least in part, and guide members **1008** are coupled to front panel **1012** of boot **1014**, and tensioning end **1016** of tension member **1010** is coupled to tensioning component **1006** at component apertures **1018**. **FIGS. 11A-B** for example illustrate component apertures **1018** of tensioning component **1006**, and **FIG. 16A** for example illustrates tensioning end **1016** of tension member **1010** coupled to tensioning component **1006**. In the example embodiment, component apertures **1018** flare open into elongated slots on bottom side **1005** of tensioning component **1006** to gently guide tension member **1010** therethrough, and plate **1004** includes primary surface **1007** that may be curved to at least partially conform to shape of panel **1012** of boot **1014**, similar to first plate **104** of first assembly **100** shown at least in **FIG. 1**.

In practice, tightening of boot **1014** is performed or perfected by application of pulling force to tensioning component **1006**, forcing first side panel **1020** and second side panel **1022** of boot **1014** together. While maintaining pulling force, tensioning component

1006 is used to wrap tension member 1010 into channel or groove 1024 formed by plate 1004. FIG. 10B for example illustrates groove 1024 formed by plate 1004. Wrapping of tension member 1010 tightly onto itself within groove 1024 fixes tension member 1010 in place, so that tension is generally maintained on tension member 1010 when pulling force is removed. Wrapping of tension member 1010 into groove 1024 proceeds until length of tension member 1010 protruding from component apertures 1018 is substantially wrapped into groove 1024. Tensioning component 1006 is then snap-coupled onto flange 1026 of plate 1004 so that locking surface 1028 of at least one flexible tab 1030 of tensioning component 1006 engages with locking surface 1032 of flange 1026 adjacent to groove 1024. FIG. 14 in a particular instance illustrates tensioning component 1006 snap-coupled onto flange 1026 of plate 1004. In the example embodiment, tensioning component 1006 may subsequently be decoupled from plate 1004 by application of leverage to tensioning component 1006 similar to that of opening certain types of aspirin containers for example, and may be used to unwind tension member 1010, thereby releasing force imparted on first side panel 1020 and second side panel 1022 of boot 1014. First side panels 1020 and/or second side panel 1022 may then be opened to allow exit, or tension reapplied to tension member 1010 as desired. Such an implementation may be beneficial or advantageous in many respects, including at least those discussed above in connection with first assembly 100.

Further, referring now specifically to FIGS. 16A-B, flexibility of second assembly 1000 is demonstrated in that tension member 1010 may be laced through plate 1004 of second assembly 1000 in a particular direction as desired. For example, FIG. 16A illustrates tension member 1010 laced through plate 1004 of second assembly 1000 in a direction extending away from front end of shoe 1014, so that tightening of shoe 1014 is perfected by application of pulling force generally in direction A. In contrast, FIG. 16B illustrates tension member 1010 laced through plate 1004 of second assembly 1000 in a direction extending towards front end of boot 1014, so that tightening of boot is perfected by application of pulling force generally in direction B.

Referring now specifically to FIGS. 11-14, second lace fixation assembly 1000 is shown in accordance with the present disclosure. FIGS. 12A-C in particular show second assembly 1000 in varying dimension, generally increasing in size from FIG. 12A proceeding in order to FIG. 12C. As mentioned above, second assembly 1000 includes plate 1004 and tensioning component 1006. When assembled, keyed aperture 1034 formed within flange 1026 of plate 1004 is positioned to complementary post 1036 of tensioning component 1006. FIG. 11A and FIG. 11B for example illustrate keyed aperture 1034 formed within flange

1026 of plate 1004, and post 1036 of tensioning component 1006. In the example embodiment, keyed aperture 1034 and post 1036 are peripherally notched. Other embodiments are however possible. Tensioning component 1006 is snap-fit coupleable to keyed aperture 1034 formed within flange 1026 of plate 1004 by at least one flexible tab  
5 1030 of tensioning component 1006 that has locking surface 1028 that engages with locking surface 1032 of flange 1026 adjacent groove 1024. FIG. 14 for example illustrates flexible tab 1030 of tensioning component 1006 that has locking surface 1028 that engages with locking surface 1032 of flange 1026 adjacent to groove 1024. In the example embodiment, rotational movement of tensioning component 1006 when coupled to plate 1004 is limited or  
10 restricted because post 1036 is rigidly fixed to plate 1004 at mounting surface 1038.

Referring now to FIG. 17, still another lace fixation system 1702 is shown in accordance with the present disclosure. System 1702 is similar to second lace fixation system 1002 as described above in many aspects. For example, system 1702 includes second lace fixation assembly 1000 of at least FIG. 10 coupled to panel 1704 of item 1706. In this  
15 example, however, second assembly 1000 is not coupled to a central panel of item 1706, and further tension member 1708 is alternately laced through guide members 1710 terminating at end 1712. In practice though, tightening of item 1706 using second assembly 1000 may be performed in a manner similar to that described above. Further, FIG. 17 demonstrates flexibility of second assembly 1000 in that second assembly 1000 may generally be coupled  
20 to a particular item at any location as desired, such as to an eyestay of a shoe as illustrated in FIG. 17. Termination at end 1712 as shown in FIG. 17 may increase the tension imparted to tension member 1708 as the system is used to close item 1706. Still other lace fixation systems embodiments are possible.

For example, referring now to FIG. 18, still another lace fixation system 1802 is  
25 shown in accordance with the present disclosure. System 1802 is similar to second lace fixation system 1002 as described above in many aspects. For example, system 1802 includes first instance 1000a of second lace fixation assembly 1000 of at least FIG. 10 coupled to first panel 1804 of item 1806. In this example, however, system 1802 further includes second instance 1000b of second lace fixation assembly 1000 coupled to second panel 1808 of item  
30 1804, and tension member 1810 is coupled to fixed guide 1812 positioned to central panel 1814 of item 1806. In some embodiments, first instance 1000a of second assembly 1000 and second instance 1000b of second assembly 1000 may be sized differently, for example as illustrated in FIG. 12. Such an implementation as shown in FIG. 18 may be an example of a zone or zonal tightening system, whereby tension imparted on first length 1816 of tension

member **1808** may be controlled by first instance **1000a** of second assembly **1000**, and tension imparted on second length **1818** of tension member **1808** may be controlled by second instance **1000b** of second assembly **1000**. Tension member **1810** may be fixedly coupled with fixed guide **1812** (i.e., the tension member **1810** may be prevented from sliding through guide **1812**) to allow zonal tensioning of a proximal and distal portion of item **1806**. Still other lace fixation system embodiments are possible.

For example, referring now to **FIGS. 19A-E**, still another lace fixation system **1902** is shown in accordance with the present disclosure. System **1902** is similar to second lace fixation system **1002** as described above in many aspects. For example, system **1902** includes embodiment **1000a** of second lace fixation assembly **1000** of at least **FIG. 10** coupled to panel **1904** of item **1906**. In this example, however, system **1902** includes tension member **1908** coupled to fixed guide **1910** positioned to central panel **1912** of item **1906**. As shown in the sequence of **FIGS. 19A-E**, tension member **1908** may be positioned to guide members **1914** and fixed guide **1910** so that tension member **1908** may be wrapped and coupled to embodiment **1000a** of second assembly **1000** in a manner such as described above. In particular, tension member **1908** may be initially laced to guide member **1914a** and guide member **1914b** positioned in a lower portion of the item, and then laced through fixed guide **1910** as shown in **FIG. 19C**, such as by inserting tension member **1908** through a lumen of fixed guide **1910**. Tensioning component **1006** may then be pulled in direction X to apply tension to first length **1916** of tension member **1908**, thereby pulling the lower portion of side panel **1918** and side panel **1920** together. Tension member **1908** may then be wrapped around a post of fixed guide **1910** to lock or maintain a tension of first length **1916** of tension member **1908** and thereby secure the lower portion in a tightened arrangement. Tension member **1908** may then be laced to guide member **1914c** and guide member **1914d** in an upper portion of the item. Tensioning component **1006** may then be pulled in direction Y to apply tension to second length **1922** of tension member **1908**, thereby pulling the upper portion of side panel **1918** and side panel **1920** together. Tension member **1908** may then be wrapped into channel or groove **1024** formed by plate **1004** to lock or maintain a tension of second length **1922** of tension member **1908** and thereby secure the upper portion in a tightened arrangement. Such an implementation as shown in **FIGS. 19A-E** may be an example of a zone or zonal tightening system, whereby tension imparted on first length **1916** of tension member **1908** may be controlled or maintained due to coupling of tension member **1908** to fixed guide **1910**, and tension imparted on second length **1922** of tension member

**1908** may be controlled or maintained due to coupling of tension member **1908** to plate **1004**. Still many other lace fixation system embodiments are possible.

Referring now to **FIG. 20**, still another lace fixation system **2002** is shown in accordance with the present disclosure. System **2002** is similar to both first lace fixation system **102** and second lace fixation system **1002** as described above in many respects. For example, system **2002** includes first lace fixation assembly **100** of at least **FIG. 1** coupled to first panel **2004** of item **2006**, and also includes second lace fixation assembly **1000** of at least **FIG. 10** coupled to second panel **2008** of item **2006**. In this example, however, system **2002** includes first tension member **2010** coupled to first assembly **100** in a manner similar to that described above, and also includes second tension member **2012** coupled to second assembly **1000** in a manner similar to that described above. Here, second tension member **2012** is shown partially in phantom line as a portion of second tension member **2012** is routed generally underneath outer shell **2014** of item **2006**, such as through tubing positioned under the upper of a boot. Such an implementation may be another example of a zone or zonal tightening system, whereby tension imparted on first tension member **2010** may be controlled by first assembly **100**, and tension imparted on second tension member **2012** may be controlled by second assembly **1000**. In the illustrated embodiment, first tension member **2010** and first assembly **100** is used to tighten an upper portion of a boot while second tension member **2012** and second lace fixation assembly **1000** is used to tighten a lower portion of a boot. Still other lace fixation system embodiments are possible.

Referring now to **FIG. 21**, still another lace fixation system **2102** is shown in accordance with the present disclosure. System **2102** is similar to second lace fixation system **1002** as described above in many respects. For example, system **2102** includes second lace fixation assembly **1000** of at least **FIG. 10** coupled to panel **2104** of item **2006**. In this example, however, second assembly **1000** is not coupled to a central or offset panel of item **2106**, and instead is coupled to rear portion **2108** of item **2106**, such as heel portion of a shoe. Further, tension member **2110** is laced to second assembly **1000** at a point furthest possible from guide members **2112** of item **2106**, such as by being routed through tubing coupled with and/or positioned under an upper material layer of the shoe. In practice though, tightening of item **2106** using second assembly **1000** may be performed in a manner similar to that described above. Further, **FIG. 21** demonstrates flexibility of second assembly **1000** in that second assembly **1000** may generally be coupled to a particular item at any location as desired. Still other lace fixation system embodiments are possible.

Referring now to **FIG. 22**, still another lace fixation system **2202** is shown in accordance with the present disclosure. System **2202** is similar to lace fixation system **2002** of **FIG. 20** as described above in many respects. In this example, however, system **2202** exhibits an alternate embodiment of first lace fixation assembly **100**. In particular, lace  
5 fixation assembly **2204** coupled to first panel **2206** of item **2208** includes reel assembly mechanism **2210** having a knob or dial component **2212** that is rotatable in a first direction (e.g., clockwise) to wind the tension member **2216** about a channel or groove of a spool (not shown) positioned under the knob **2212** and within a housing **2214** of the reel assembly mechanism **2210**. The tension member **2216** is laced and/or positioned around one or more  
10 guides of an upper portion of item **2208** (i.e., boot). The reel assembly mechanism **2210** is used to tighten the upper portion of item **2208** by tensioning the tension member **2216** via reel assembly mechanism **2210**. In some embodiments, the reel assembly mechanism **2210** may be rotated in a second direction (i.e., counter-clockwise) to loosen the tension in tension member **2216** and thereby loosen the upper portion of item **2208**. In other embodiments, the  
15 knob **2212** may be grasped and moved axially upward to disengage internal components of reel assembly mechanism **2210** and thereby release the tension on tension member **2216**. Second assembly **1000** may be used to tension a lower portion of item **2208** as described in the embodiment of **FIG. 20**. Still other lace fixation assembly embodiments are possible.

For example, referring now to **FIGS. 23A-C**, third lace fixation assembly **2300** is  
20 shown in accordance with the present disclosure. In the example embodiment, tension member **2302** is laced through plate **2304** of third assembly **2300** via lumen or passage **2306** that guides tension member **2302** through plate **2304**, and tensioning end **2308** of tension member **2302** is coupled to tensioning component **2310** at component apertures **2312**. As shown in particular by the sequence of **FIG. 23C**, tensioning component **2310** may initially  
25 be pulled in direction C so that tension member **2302** in turn is pulled through passage **2306**. Tensioning component **2310** may then be flipped or positioned back over plate **2304** whereby portions of tension member **2302** are engaged with ridged friction surfaces **2314** within channel **2316** of plate **2304**. The ridged friction surfaces **2314** engage with tension member **2302** to lock or otherwise maintain the tension member **2302** in a tensioned stated.

**FIG. 23A** and **FIG. 23B** too for example illustrates portions of tension member **2302**  
30 engaged with ridged friction surfaces **2314** within channel **2316** of plate **2304**. Tensioning component **2310** may then be pulled in direction D that is generally opposite direction C so that slack of tension member **2302** is taken up and portions of tension member **2302** are fully engaged with ridged friction surfaces **2314** within channel **2316** to lock or otherwise maintain



the tension member **2302** in the tensioned state. Tensioning component **2310** may then be used to wrap tension member **2302** within second channel **2318** of plate **2304** in rotational direction E and then snap-coupled to flange **2138** of plate **2304** in a manner similar to that described above in connection with tensioning component **1006**. Second channel **2318** may be separated from channel **2316** via a flange or other partition member. In the example embodiment, plate **2304** and tensioning component **2310** of at least **FIG. 23** are configured in a manner substantially similar to plate **1004** tensioning component **1006** of at least **FIG. 10A-D**, with at least the exception of ridged friction surfaces **2314**. Still other lace fixation assembly embodiments are possible.

Referring now to **FIGS. 24A-B**, fourth lace fixation assembly **2400** is shown in accordance with the present disclosure. In the example embodiment, fourth assembly **2400** is substantially similar to second lace fixation assembly **1002** as described above. Fourth assembly **2400** though is configured to exhibit coiler functionality. As shown in particular by the sequence of **FIG. 24B**, tensioning component **1006** may initially be pulled in direction F so that tension member **1010** in turn is pulled through plate **1004**. Post **2402** of plate **1004** may then be rotated in direction G to pull and wind tension member **1010** to groove **1024** formed by plate **1004** (e.g., see **FIG. 10**). Tensioning component **1006** may then be snap-coupled onto flange **1026** of plate **1004** in manner as described above. In the example embodiment, post **2402** of plate **1004** may be configured and arranged as a rotary dial having a clock spring or spiral-wound torsion spring so that tension member **1010** may be automatically wound to groove **1024** formed by plate **1004** without a user having to use tensioning component **1006** to wrap tension member **1010** to groove **1024** as describe above. In this manner, the user may simply pull tensioning component **1006** in direction F and then release tensioning component **1006** or gently guide tensioning component **1006** as post **2402** automatically rotates in direction G to wind tension member **1010** about groove **1024**. In other embodiments, the user may rotate post **2402** in direction G to wind the tension member **1010** about groove **1024**. In some embodiments, post **2402** may further be configured and arranged to exhibit push-to-lock/pull-to-unlock functionality whereby when tension member **1010** is fully wrapped to groove **1024** tensioning component **1006** may be pressed to lock second assembly **1002**. A reverse operation may be performed to unlock second assembly **1002** so that tension member **1010** may be unwound from groove **1024**. Still other lace fixation assembly embodiments are possible.

Referring now to **FIG. 25**, fifth lace fixation assembly **2500** is shown in accordance with the present disclosure. In the example embodiment, fifth lace fixation assembly **2500** is

substantially similar to second lace fixation assembly **1002** as described above. Fifth assembly **2500** though is configured to exhibit incremental tightening/loosening functionality. For example, as shown in particular by the sequence of **FIG. 25**, tensioning component **1006** may initially be pulled in direction H so that tension member **1010** in turn is pulled through plate **1004**. Tensioning component **1006** may then be used to wrap tension member **1010** to groove **1024** and then snap-coupled onto flange **1026** of plate **1004** in manner as described above. Subsequently, a fine tuning operation may be performed to increase or release tension on tension member **1010**. In particular, tensioning component **1006** may be incrementally rotated in a clockwise direction in a fixed ratcheting motion to increase tension on tension member **1010**, or incrementally rotated in a counterclockwise direction in the fixed ratcheting motion to release tension on tension member **1010**. In the example embodiment, post **2402** of plate **1004** (e.g., see **FIG. 24**) may be configured and arranged as a ratcheted rotary dial so that tension on tension member **1010** may be increased or decreased as desired, without having to decouple tensioning component **1006** from plate **1004**.

Although the various disclosed lace fixation assemblies and systems are described in the context of a closure system for footwear or other panels desired to be closed toward one another, it will be appreciated that the designs may be optimized for a variety of other uses in which a lace or cord is desired to be removably secured at various tension levels or adjustment lengths. Examples include: a) fixation of high tensile rigging aboard ships, allowing for easy adjustment of a given line with secure fixation, b) orthopedic bracing products, c) garment closures, d) equestrian accessories, e) wakeboard boots, f) kitesurfing line adjustments, g) backpack and luggage closures.

Having described several embodiments, it will be recognized by those of skill in the art that various modifications, alternative constructions, and equivalents may be used without departing from the spirit of the invention. Additionally, a number of well-known processes and elements have not been described in order to avoid unnecessarily obscuring the present invention. Accordingly, the above description should not be taken as limiting the scope of the invention.

As used herein and in the appended claims, the singular forms “a”, “an”, and “the” include plural referents unless the context clearly dictates otherwise. Thus, for example, reference to “a process” includes a plurality of such processes and reference to “the device” includes reference to one or more devices and equivalents thereof known to those skilled in the art, and so forth. Also, the words “comprise,” “comprising,” “include,” “including,” and “includes” when used in this specification and in the following claims are intended to specify

the presence of stated features, integers, components, or steps, but they do not preclude the presence or addition of one or more other features, integers, components, steps, acts, or groups.

**WHAT IS CLAIMED IS:**

1. A lacing system for tightening an article, comprising:
  - a fixation member coupled to the article, the fixation member having at least one entry aperture and an exit aperture with a lumen extending therebetween, the fixation member also having a spool with a fixation post;
  - a tension member having an intermediate portion slidably disposed within the lumen of the fixation member such that a proximal portion of the tension member is positioned on a proximal side of the fixation member and a distal portion of the tension member is positioned on a distal side of the fixation member and such that a length of the proximal portion and a length of the distal portion is adjustable via sliding of the tension member within the lumen;
  - a plurality of guide members coupled to the article on the proximal side of the fixation member to guide the proximal portion of the tension member along the article to the fixation member; and
  - a tensioning component coupled to the distal portion of the tension member to effect sliding of the tension member within the lumen and thereby tighten the article by adjusting the length of the proximal portion of the tension member, and to maintain a tightness of the article by winding of the tension member about the fixation post, wherein the tensioning component is securable to the spool of the fixation member.
2. The system of claim 1, wherein the fixation member further includes a flange shaped complementary to the panel.
3. The system of claim 1, wherein the lumen extending between the entry aperture and the exit apertures includes an arcuate configuration.
4. The system of claim 1, wherein the plurality of guide members direct the tension member along the panel of the article without overlap to the at least one entry aperture.
5. The system of claim 1, wherein the plurality of guide members direct the tension member along the panel of the article with overlap to the at least one entry aperture.
6. The system of claim 1, wherein the tensioning component is ring-shaped.

7. The system of claim 1, wherein the tensioning component is snap-fit coupleable about the spool.

8. The system of claim 1, wherein the spool and the tensioning component each comprise a plurality of traction members that when engaged inhibit rotation of the tensioning component when the tensioning component is secured about the spool.

9. A lacing system for tightening an article, comprising:

a first plate coupleable to a first panel of the article and defining at least one lacing entry aperture, a lacing exit aperture, and a keyed protrusion that is positioned to a complementary recess of a second plate of the lacing system to form a groove with a lacing fixation post; and

a lacing tensioner coupleable to lacing protruding from the lacing exit aperture and to a periphery of the groove so that the lacing tensioner is securable to the groove when lacing protruding from the lacing exit aperture is wound to the lacing fixation post for tightening the article by pulling together a second panel and a third panel of the article.

10. The system of claim 9, the first plate further defining a first plurality of ridged flutes extending radially from the keyed protrusion in a spoke pattern, and the second plate further defining a second plurality of ridged flutes extending radially from the recess in the spoke pattern and offset the first plurality of ridged flutes, to maintain lacing tension when lacing protruding from the lacing exit aperture is wound to the lacing fixation post for tightening the article.

11. The system of claim 9, further comprising a plurality of lacing guide members coupleable to the first panel to direct lacing along the first panel to the at least one lacing entry aperture and through the lacing exit aperture

12. The system of claim 9, further comprising a fastener positioned through an aperture of the keyed protrusion and an aperture of the recess to rigidly secure the keyed protrusion to the recess.

13. A method for tightening an article, comprising:

for a lacing system having:

a fixation member coupled to the article, the fixation member having at least one entry aperture and an exit aperture with a lumen extending therebetween, and also having a spool with a fixation post;

a tension member having an intermediate portion slidably disposed within the lumen of the fixation member so that a proximal portion of the tension member is positioned on a proximal side of the fixation member and a distal portion of the tension member is positioned on a distal side of the fixation member;

a plurality of guide members coupled to the article on the proximal side of the fixation member to guide the proximal portion of the tension member about the article to the fixation member; and

a tensioning component coupled to the distal portion of the tension member;

tensioning the tension member via the tensioning component to effect sliding of the tension member within the lumen and thereby tighten the article by shortening the length of the proximal portion of the tension member, and

winding the tension member about the fixation post via the tensioning component to maintain a tightness of the article, wherein the tensioning component is securable to the spool of the fixation member.

**14.** The method of claim **13**, further comprising securing the tensioning component to the spool of the fixation member.

**15.** The method of claim **13**, further comprising positioning the tension member to the lumen of the fixation member to lace the tension member to the fixation member.

**16.** The method of claim **13**, further comprising positioning the tension member to the plurality of guide members to lace the tension member to the plurality of guide members without overlap of the tension member.

**17.** The method of claim **13**, further comprising positioning the tension member to the plurality of guide members to lace the tension member to the plurality of guide members with overlap of the tension member.

**18.** The method of claim **13**, further comprising positioning the tension member to the tensioning component to couple the tension member to the tensioning component.

**19.** The method of claim **13**, further comprising winding the tension member within a gap about the fixation post that includes a plurality of radially offset ridged flutes to engage and maintain tension to the tension member.

**20.** The method of claim **13**, further comprising winding excess length of the tension member within a gap about the fixation post to store the excess length of tension member about the fixation post.

100

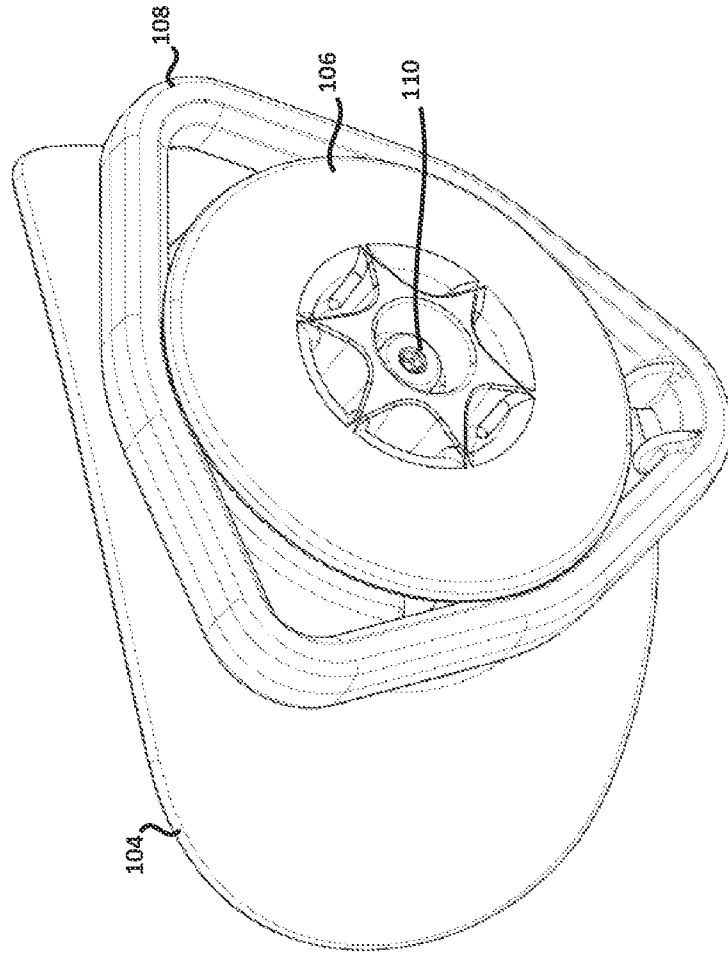

FIG. 1



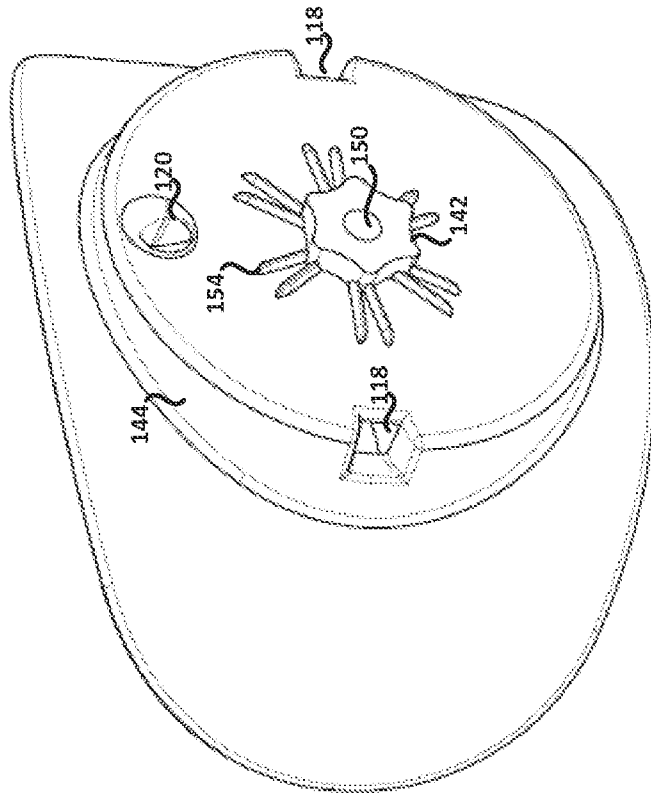

FIG. 2

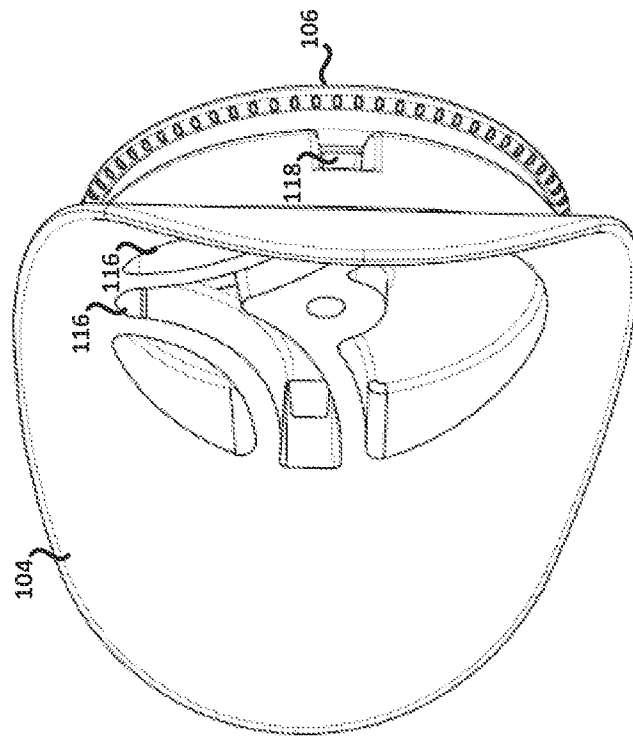

FIG. 3

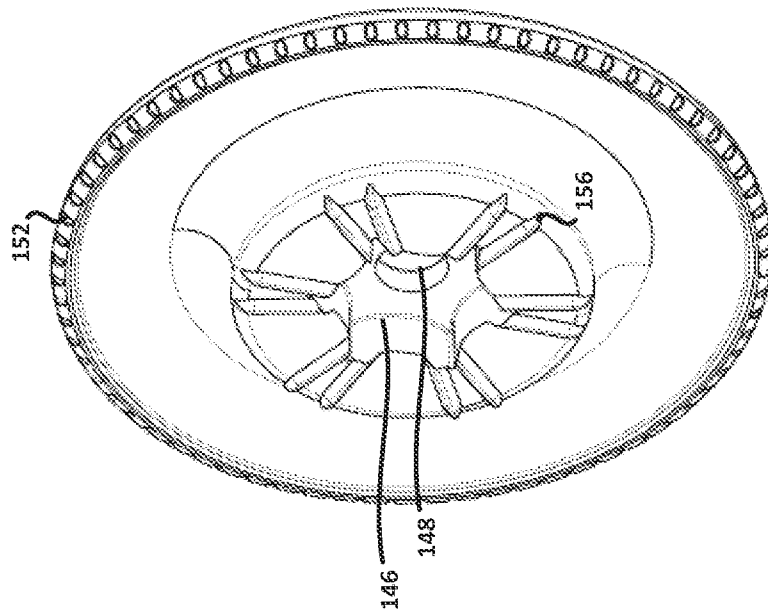

FIG. 4

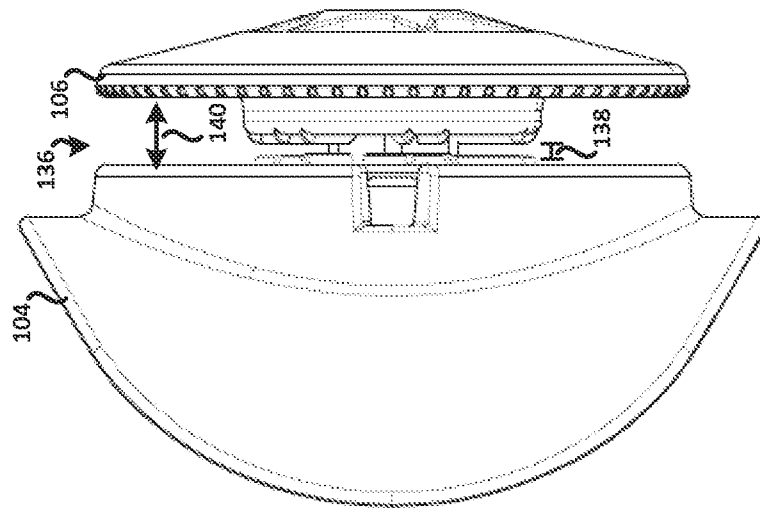

FIG. 5

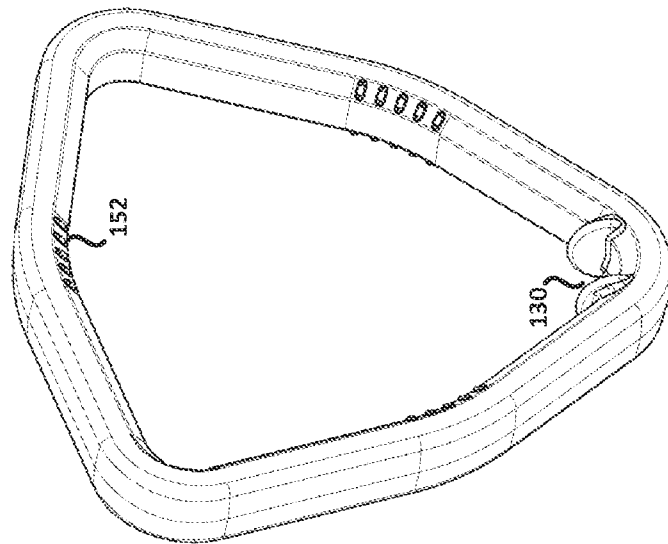
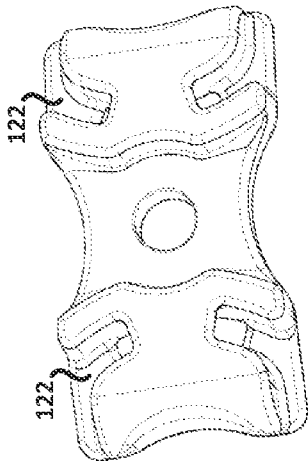
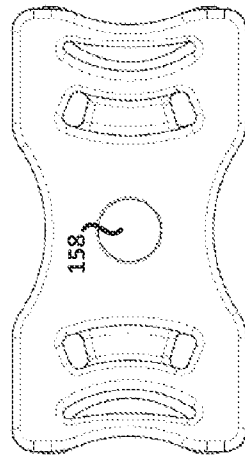

FIG. 6



**FIG. 7A**



**FIG. 7B**

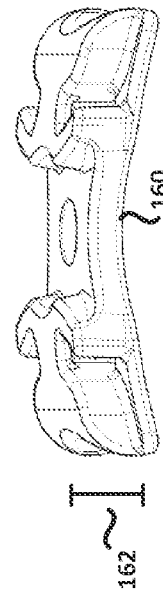

**FIG. 7C**

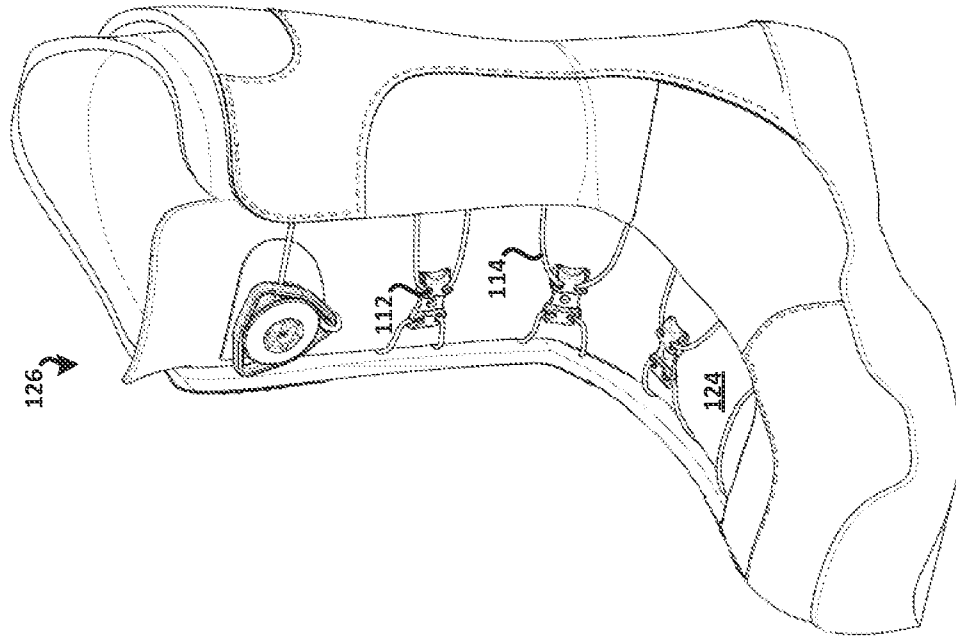

FIG. 8A

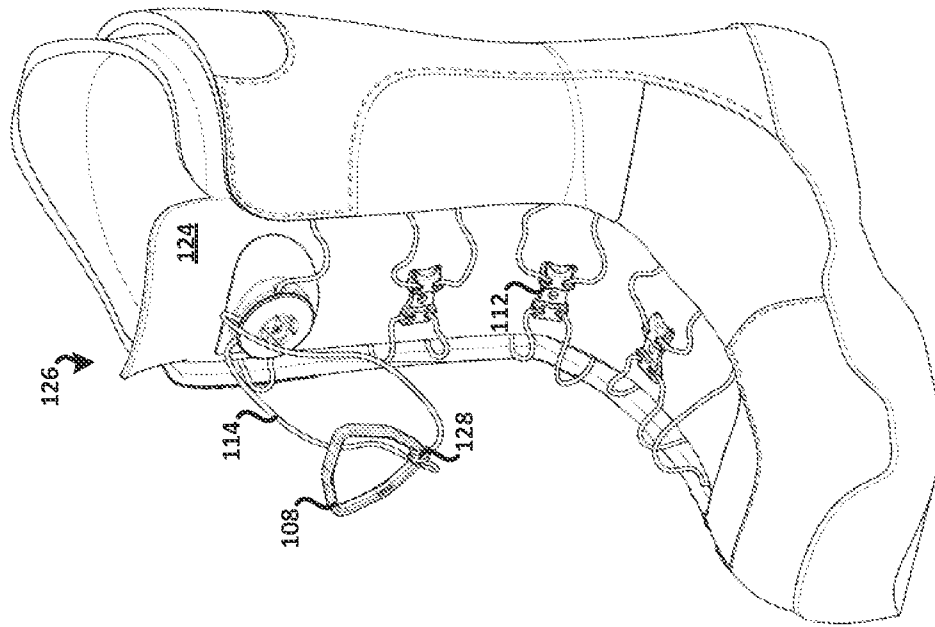

FIG. 8B



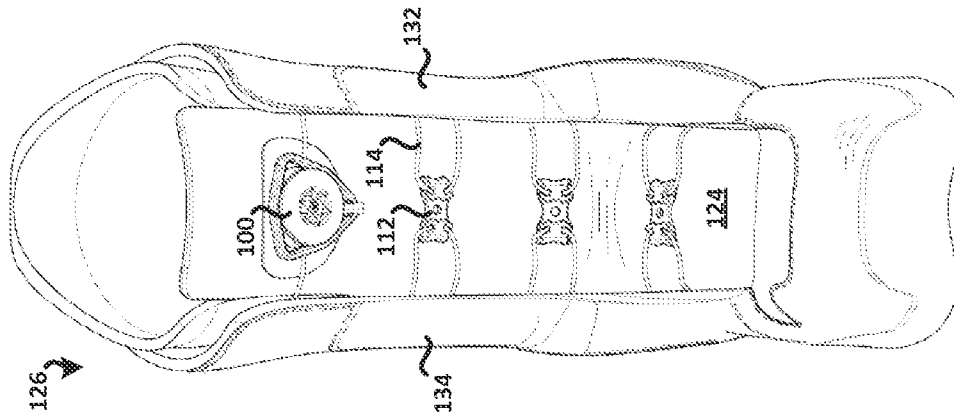

FIG. 8C

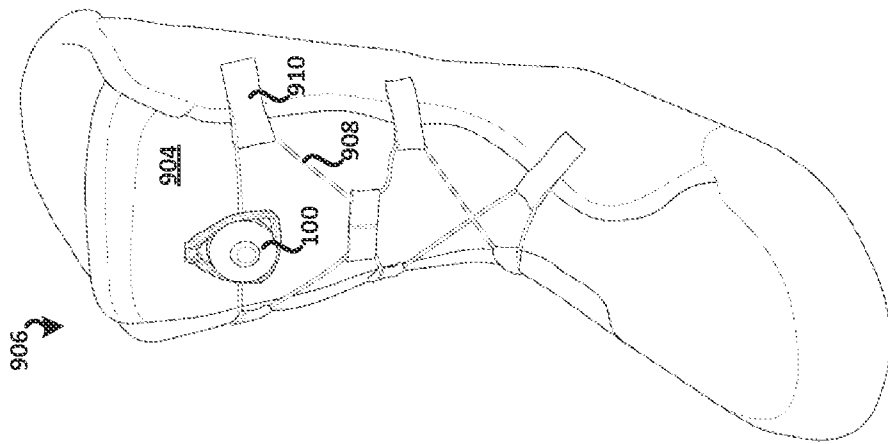

FIG. 9

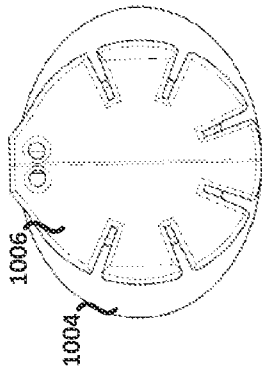

FIG. 10A

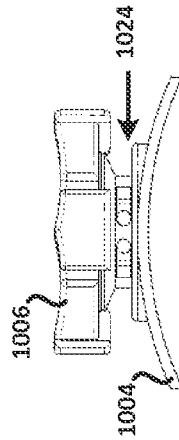

FIG. 10B

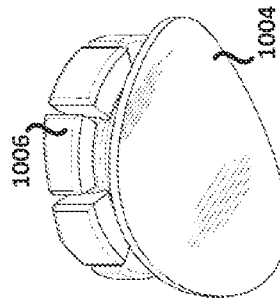

FIG. 10C

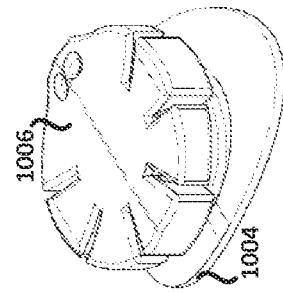

FIG. 10D

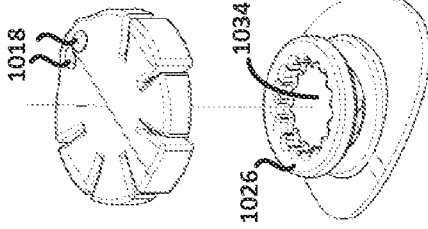

FIG. 11A

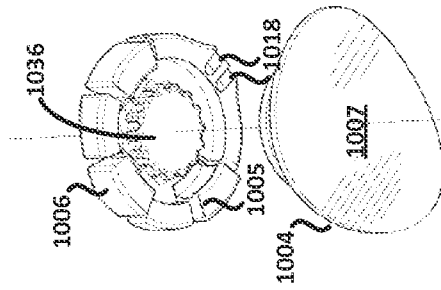

FIG. 11B

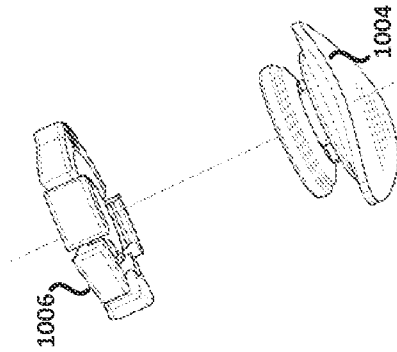
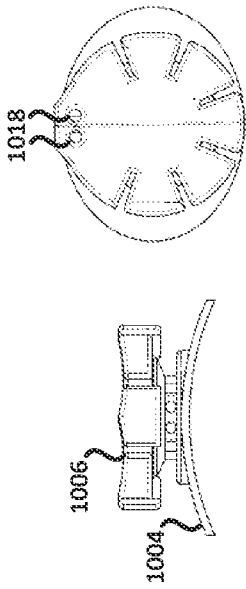
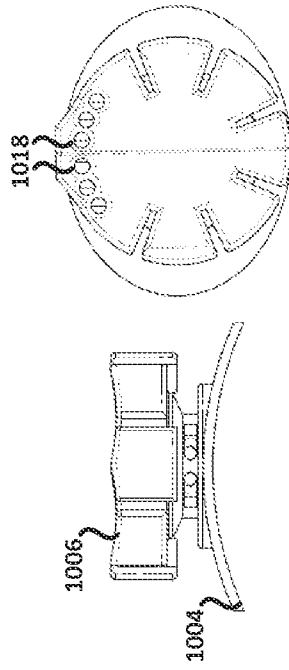

FIG. 11C



**FIG. 12A**



**FIG. 12B**

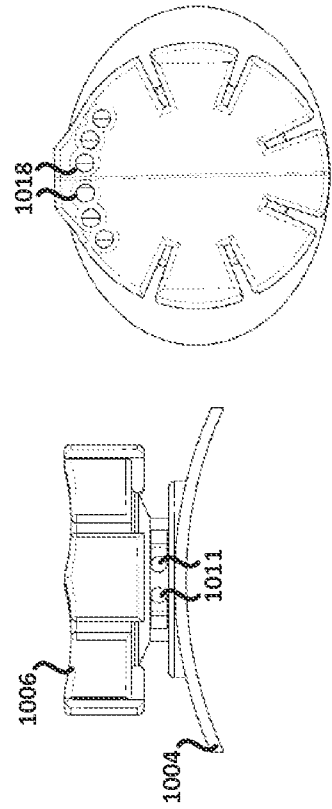

**FIG. 12C**

1000

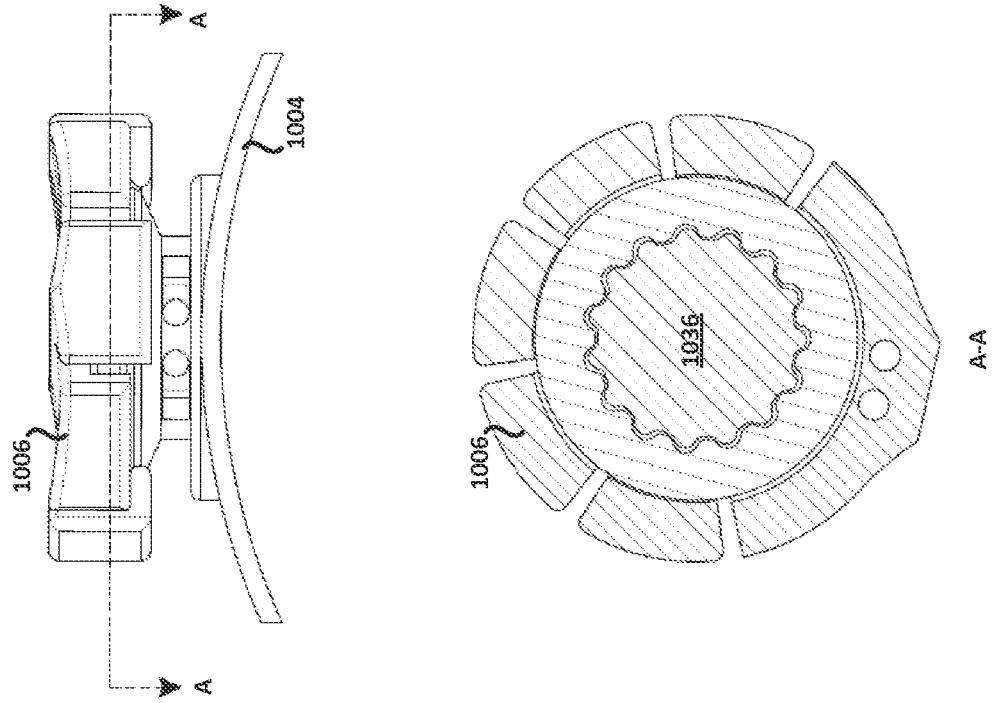

FIG. 13

1000

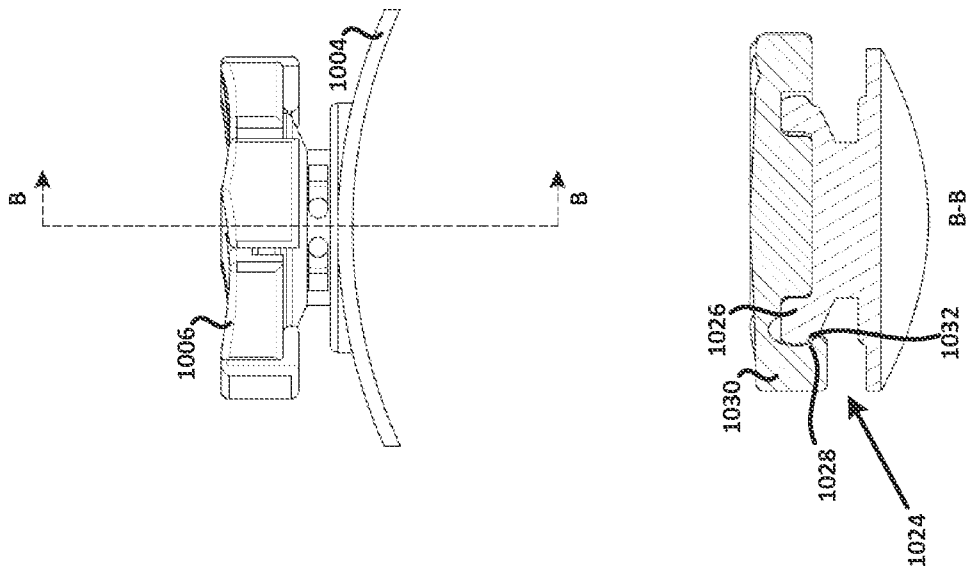

FIG. 14

1002

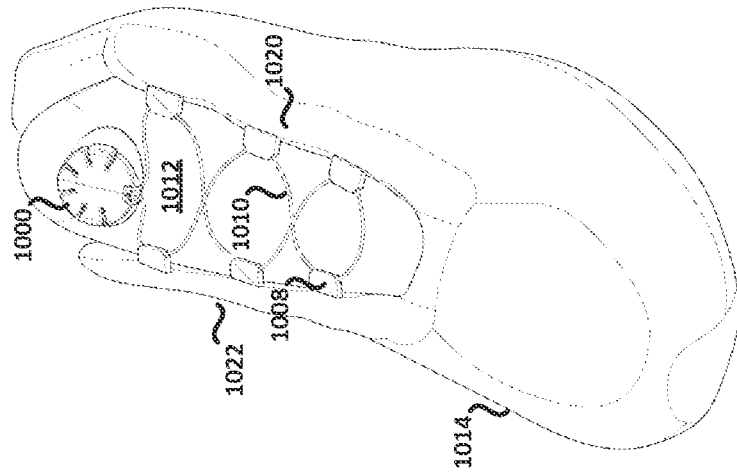

FIG. 15



1002

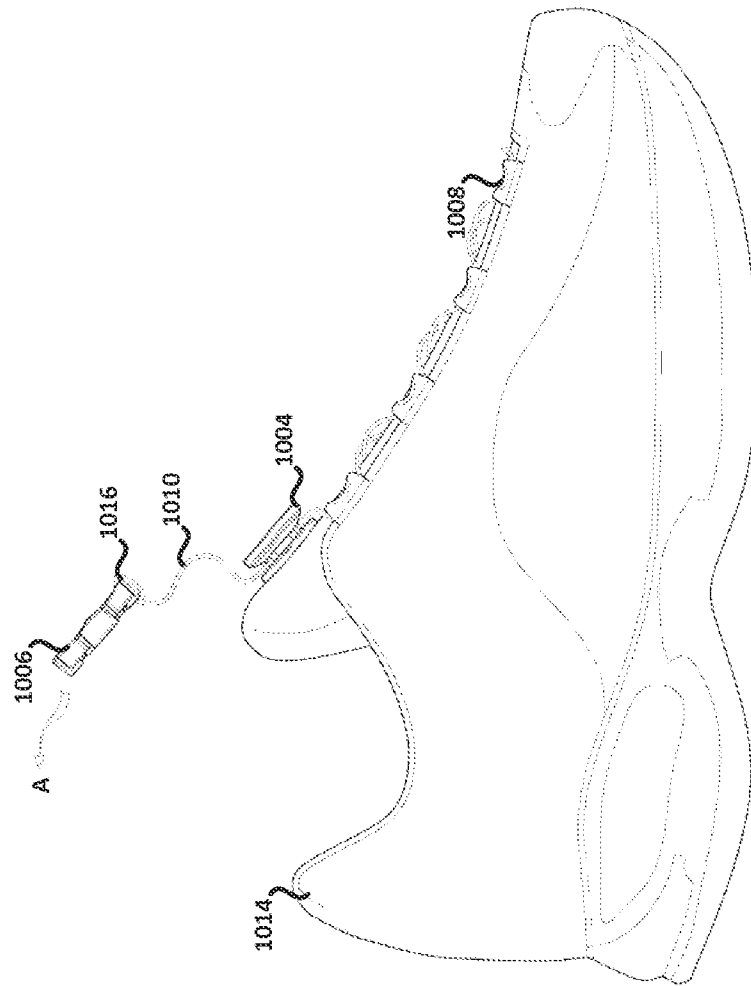

FIG. 16A

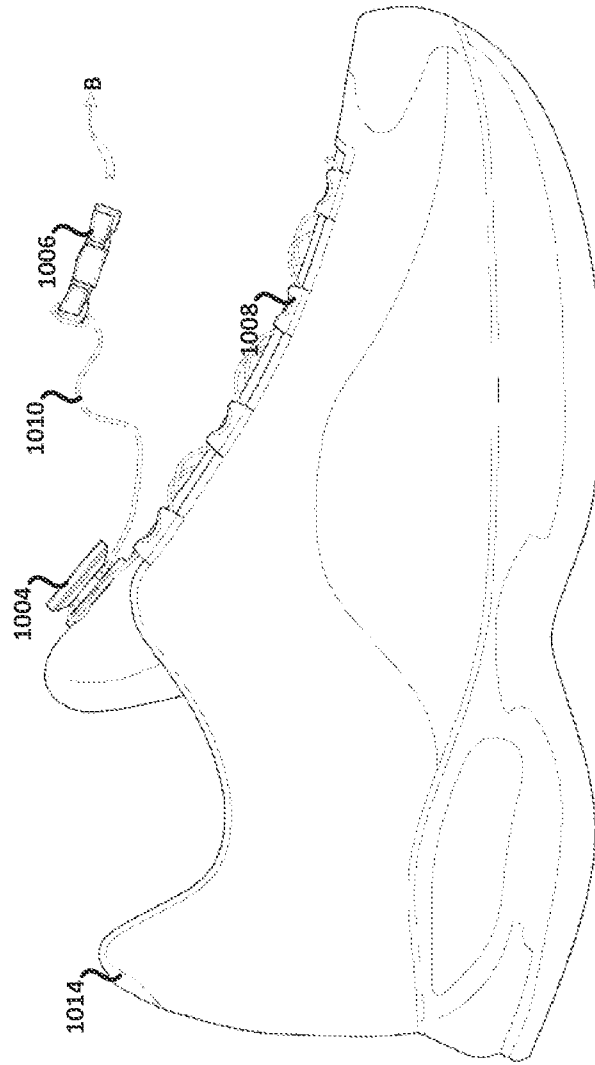

FIG. 16B

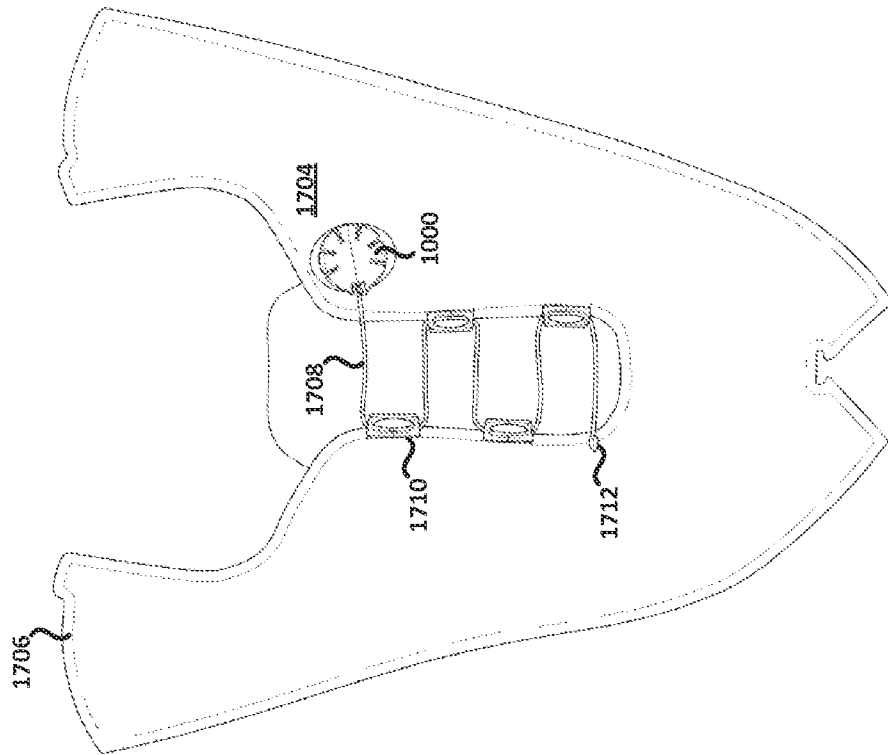

FIG. 17

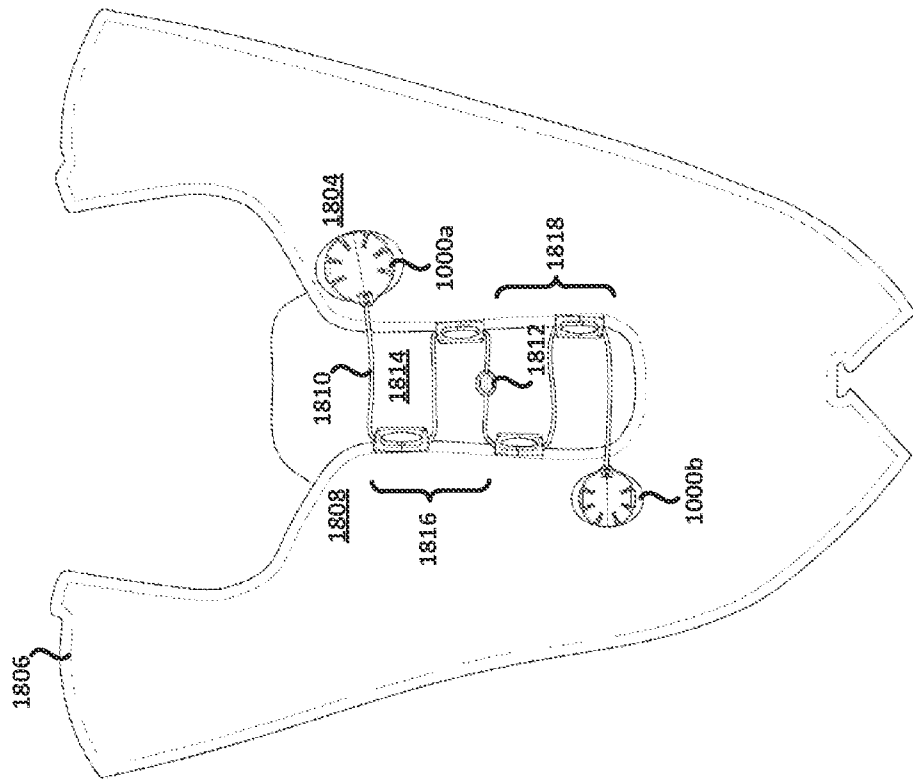

FIG. 18

1902

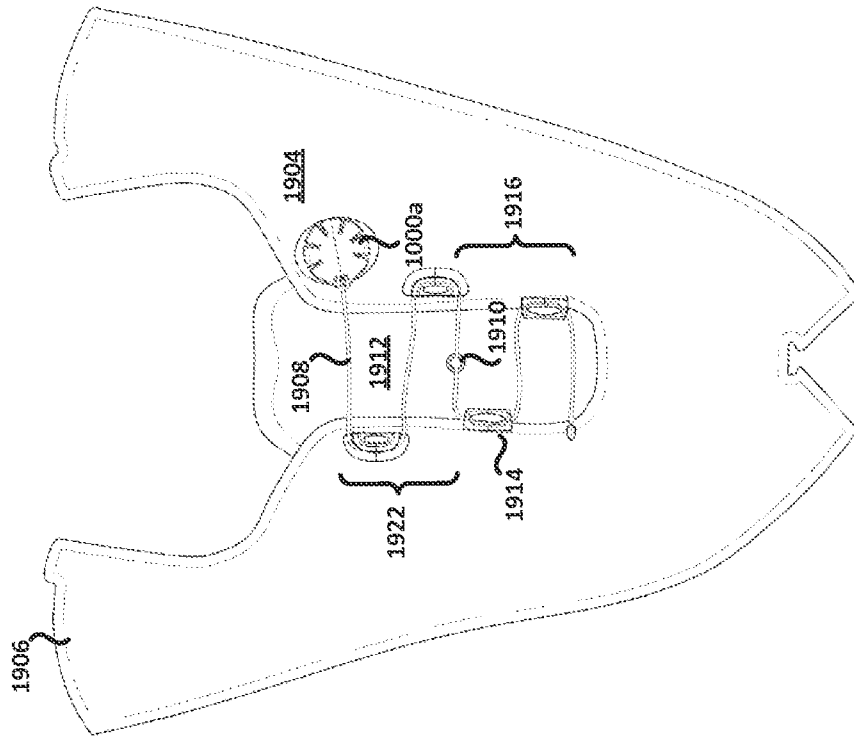

FIG. 19A

1902

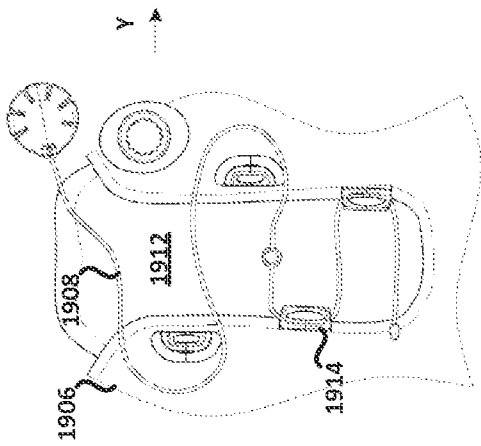

FIG. 19B

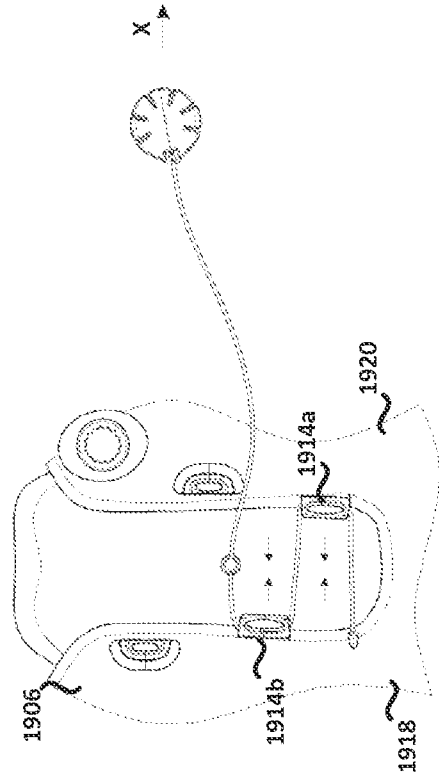

FIG. 19C

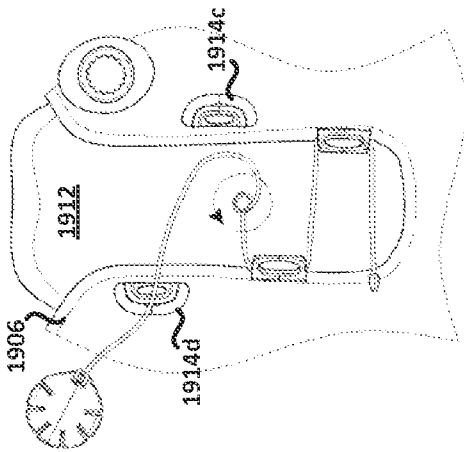

FIG. 19D

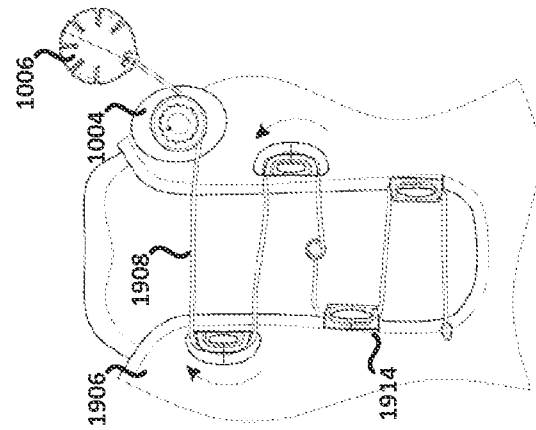

FIG. 19E

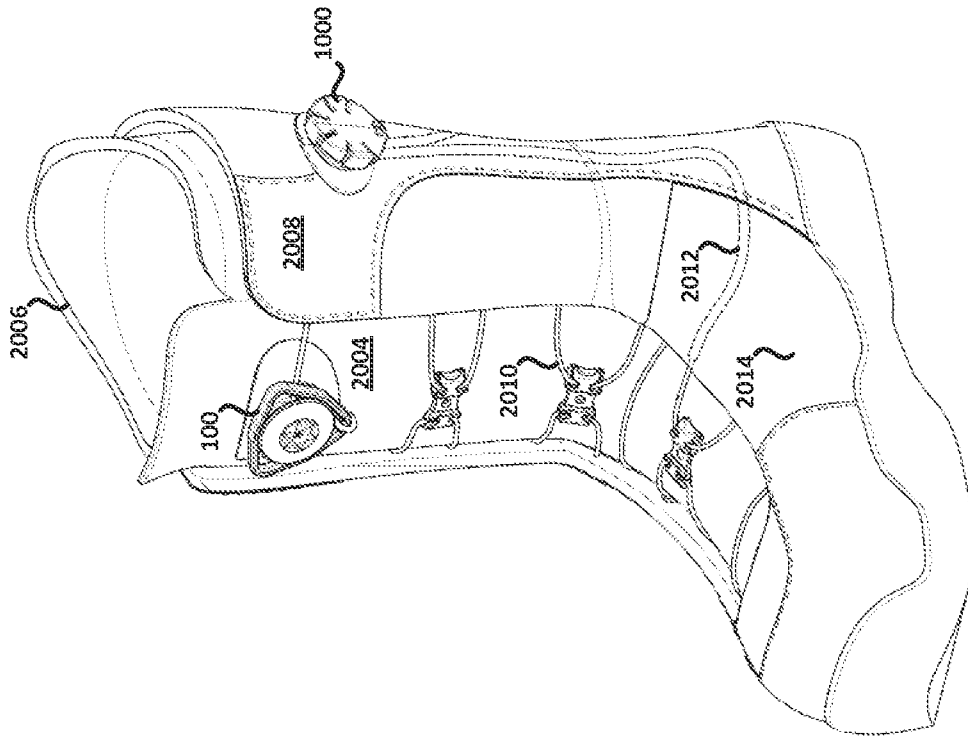

FIG. 20



2102

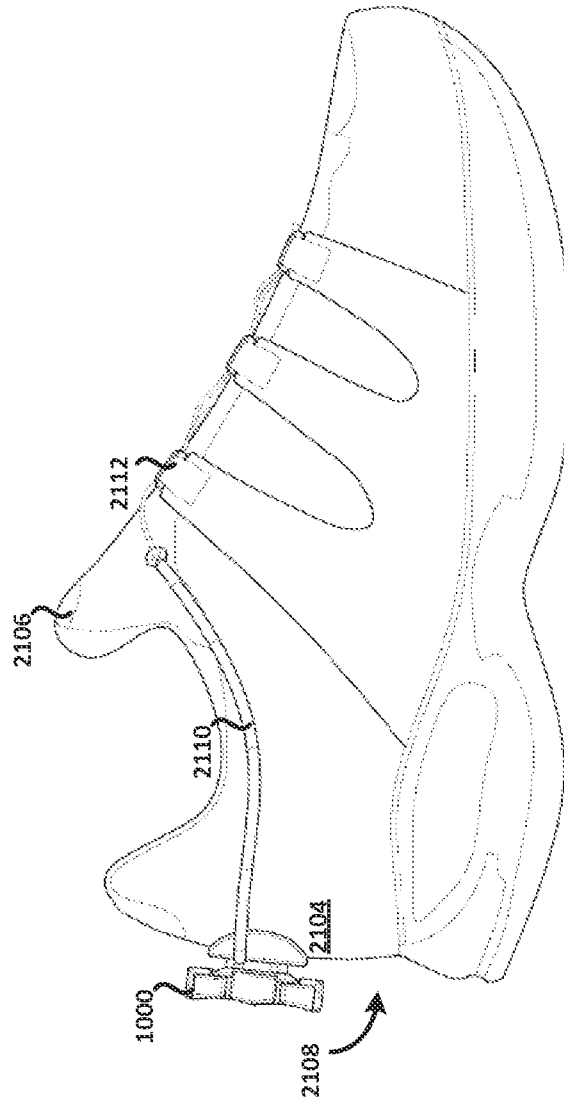

FIG. 21

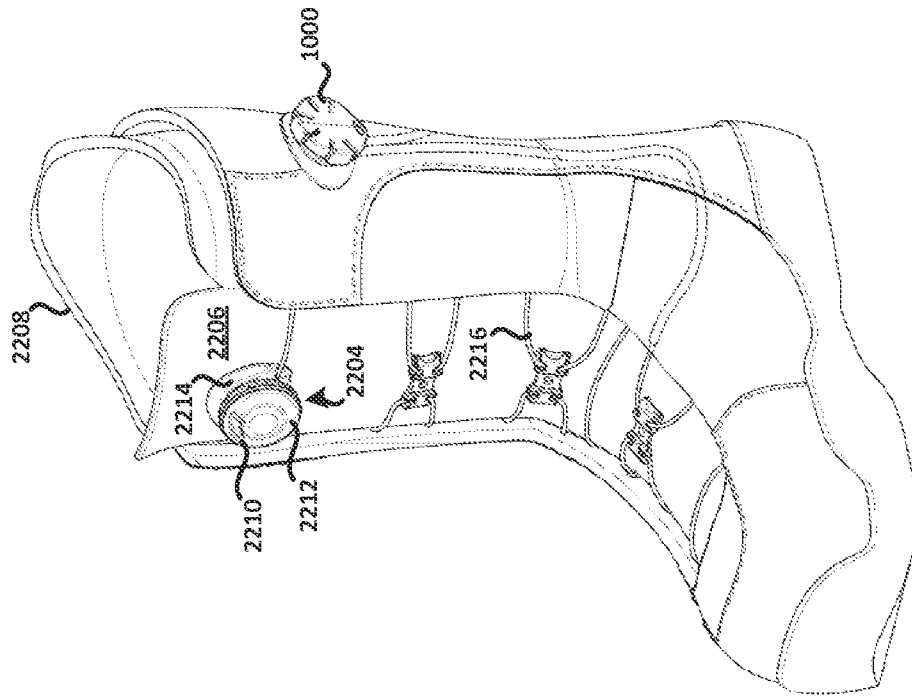

FIG. 22

2300

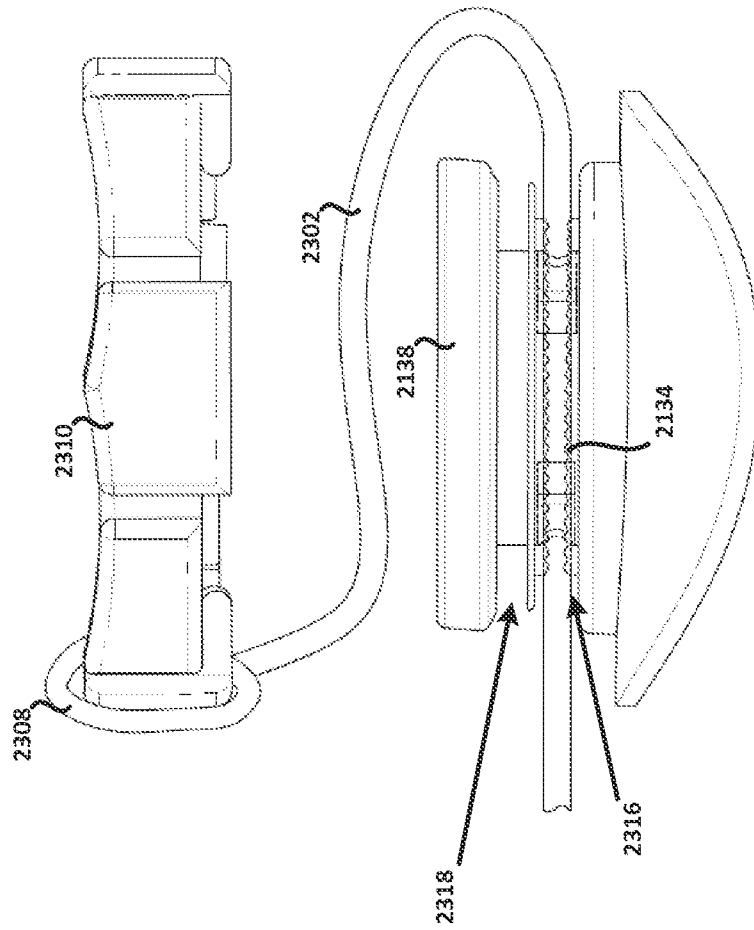

FIG. 23A

2300

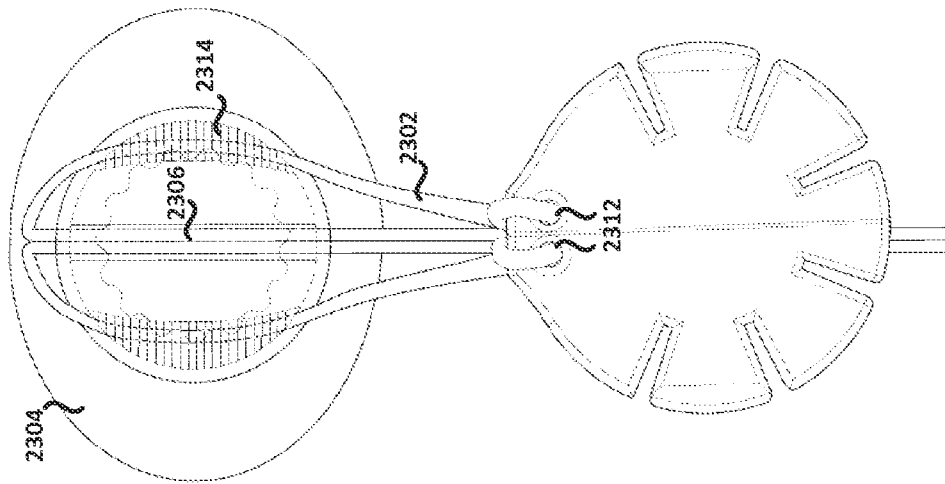

FIG. 23B

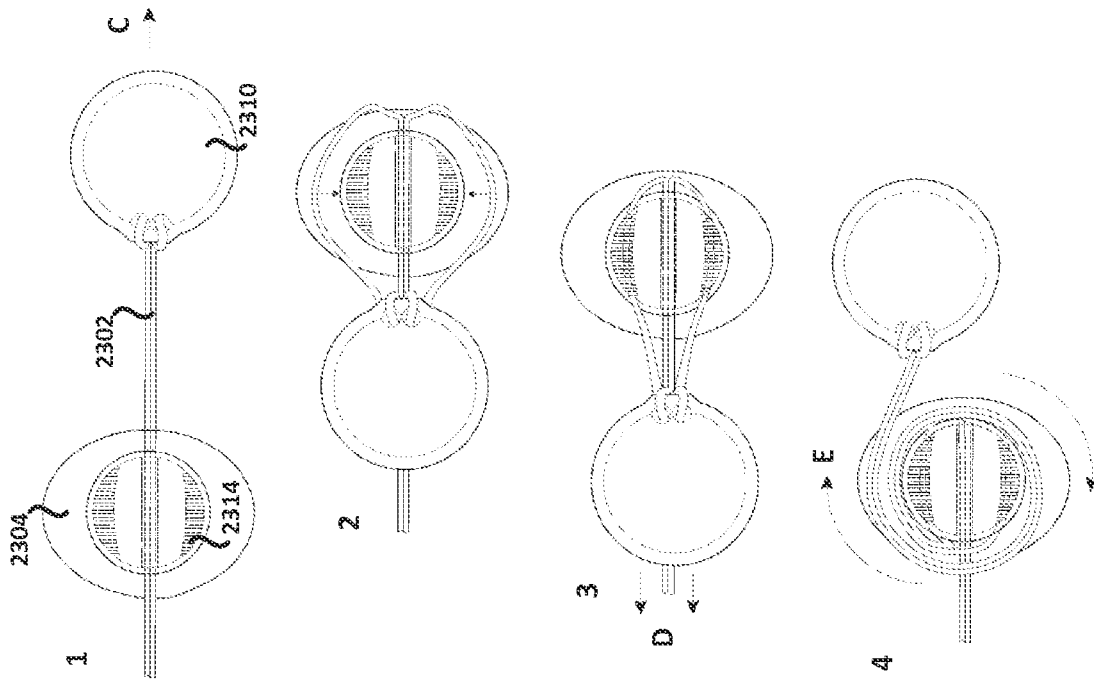

FIG. 23C

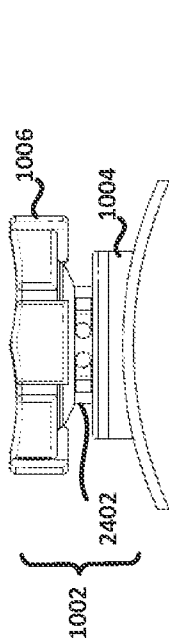

FIG. 24A

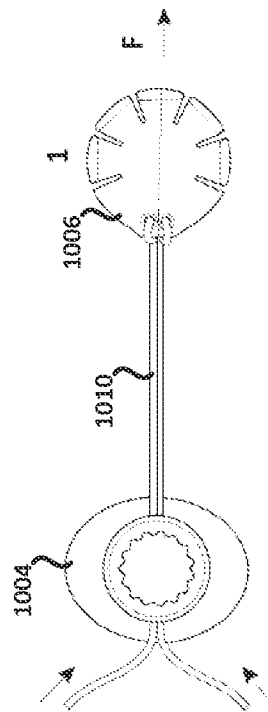

FIG. 24B

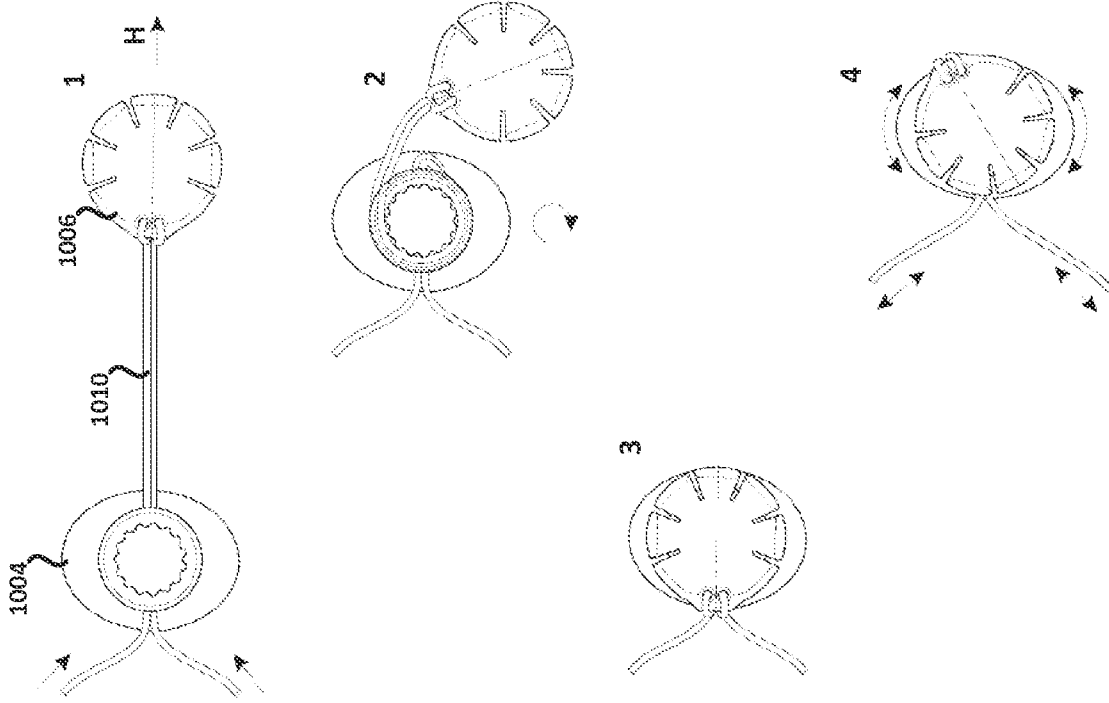

FIG. 25

INTERNATIONAL SEARCH REPORT

International application No.

PCT/US2014/013458

A. CLASSIFICATION OF SUBJECT MATTER

IPC(8) - A43C 1/00 (2014.01)

USPC - 24/712.9

According to International Patent Classification (IPC) or to both national classification and IPC

B. FIELDS SEARCHED

Minimum documentation searched (classification system followed by classification symbols)

IPC(8) - A43C 1/00, 7/00, 11/00, 11/12, 11/16 (2014.01)

USPC - 24/114.4, 130, 712.1, 712.5, 712.6, 712.7, 712.9, 713.2, 713.5; 36/50.1

Documentation searched other than minimum documentation to the extent that such documents are included in the fields searched  
CPC - A43C 1/00, 7/00, 11/165 (2014.02)

Electronic data base consulted during the international search (name of data base and, where practicable, search terms used)

PatBase, Google Patents, Google

C. DOCUMENTS CONSIDERED TO BE RELEVANT

Category*	Citation of document, with indication, where appropriate, of the relevant passages	Relevant to claim No.
X	US 6,502,286 B1 (DUBBERKE) 07 January 2003 (07.01.2003) entire document	1-3,5-9,11-15,17-20
Y		4,16
Y	US 5,117,567 A (BERGER) 02 June 1992 (02.06.1992) entire document	4,16
Y	US 2005/0172463 A1 (ROLLA) 11 August 2005 (11.08.2005) entire document	1-20
Y	US 5,315,741 A (DUBBERKE) 31 May 1994 (31.05.1994) entire document	1-20

Further documents are listed in the continuation of Box C.

\* Special categories of cited documents:

"A" document defining the general state of the art which is not considered to be of particular relevance

"E" earlier application or patent but published on or after the international filing date

"L" document which may throw doubts on priority claim(s) or which is cited to establish the publication date of another citation or other special reason (as specified)

"O" document referring to an oral disclosure, use, exhibition or other means

"P" document published prior to the international filing date but later than the priority date claimed

"T" later document published after the international filing date or priority date and not in conflict with the application but cited to understand the principle or theory underlying the invention

"X" document of particular relevance; the claimed invention cannot be considered novel or cannot be considered to involve an inventive step when the document is taken alone

"Y" document of particular relevance; the claimed invention cannot be considered to involve an inventive step when the document is combined with one or more other such documents, such combination being obvious to a person skilled in the art

"&" document member of the same patent family

Date of the actual completion of the international search

05 May 2014

Date of mailing of the international search report

19 MAY 2014

Name and mailing address of the ISA/US

Mail Stop PCT, Attn: ISA/US, Commissioner for Patents  
P.O. Box 1450, Alexandria, Virginia 22313-1450

Facsimile No. 571-273-3201

Authorized officer:

Blaine R. Copenheaver

PCT Helpdesk: 571-272-4300  
PCT OSP: 571-272-7774