

[54] HIP FIXATION DEVICE

[76] Inventor: Richard F. Wagner, 62 San Jacinto Way, San Francisco, Calif. 94127

[22] Filed: Nov. 12, 1973

[21] Appl. No.: 414,711

[52] U.S. Cl. .... 128/92 BB, 128/92 B

[51] Int. Cl. .... A61f 5/04

[58] Field of Search ..... 128/92 BB, 92 B, 92 R, 128/92 BC, 92 CA, 92 C, 92 D, 83

[56] References Cited

UNITED STATES PATENTS

2,397,545	4/1946	Hardinge.....	128/92 B
2,414,882	1/1947	Longfellow .....	128/92 BB
2,952,254	9/1960	Keating.....	128/92 BB
3,489,143	1/1970	Halloran .....	128/92 R

Primary Examiner—Richard A. Gaudet  
 Assistant Examiner—J. Yasko  
 Attorney, Agent, or Firm—Townsend and Townsend

[57] ABSTRACT

A hip fixation device for reconstructing fractures of the upper end of the femur comprising a spoon-shaped plate having a handle portion which extends laterally along the top of the femur shaft and a bowl portion which conforms to the lower portion of the greater trochanter. A plurality of bores transverse the bowl portion for receiving hip screws adapted to be driven into the upper end of the femur generally parallel to the long axis of the femur head and a flat headed boss surrounds the outer opening of each bore against which the undersides of the screw heads seat. A cover plate is attached tightly over the outer side of the bowl portion against the screw heads by means of bolts. It has a raised section on its inner side which fits down between the screw heads to keep them from rotating. A pair of bending tools for bending the spoon shaped plate so that it conforms to the femur contour and a driving tool for driving the hip screws into the femur are also disclosed.

9 Claims, 12 Drawing Figures

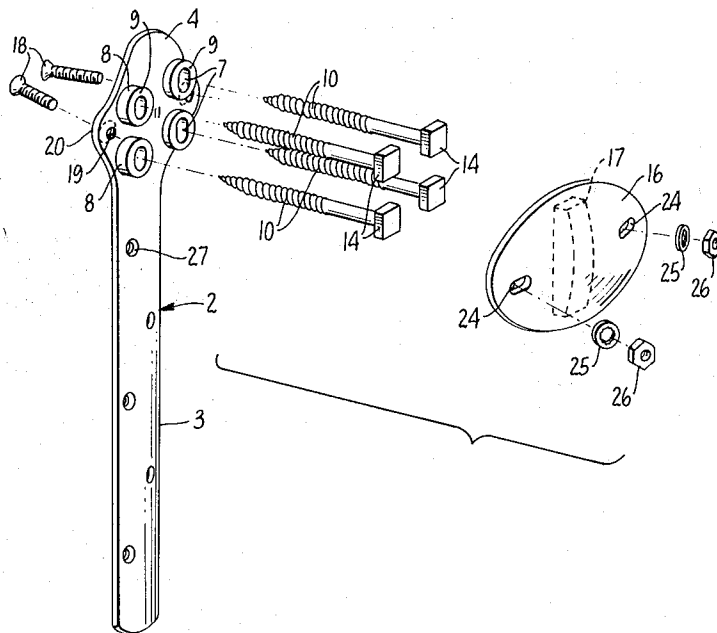

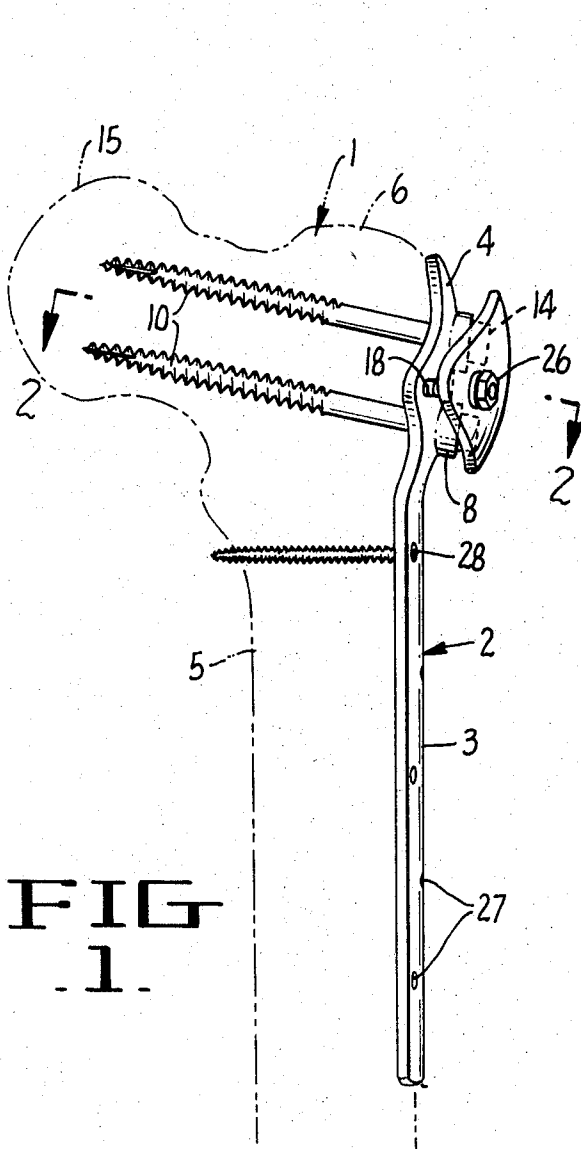

FIG. 1.

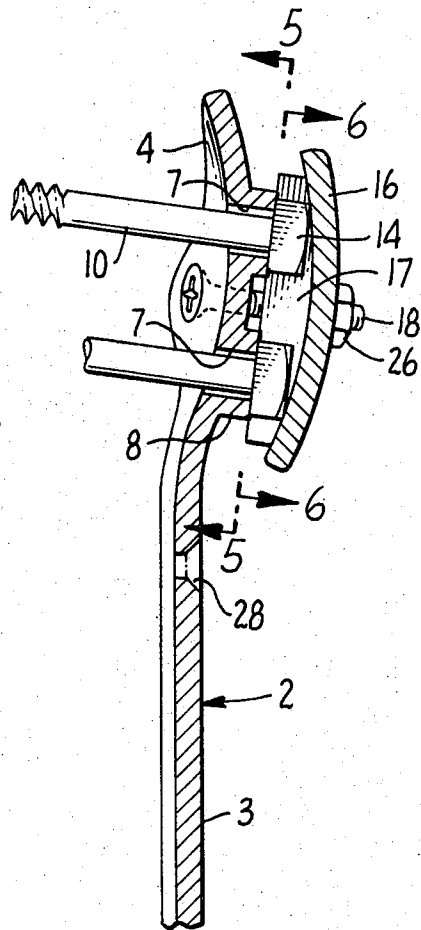

FIG. 3.

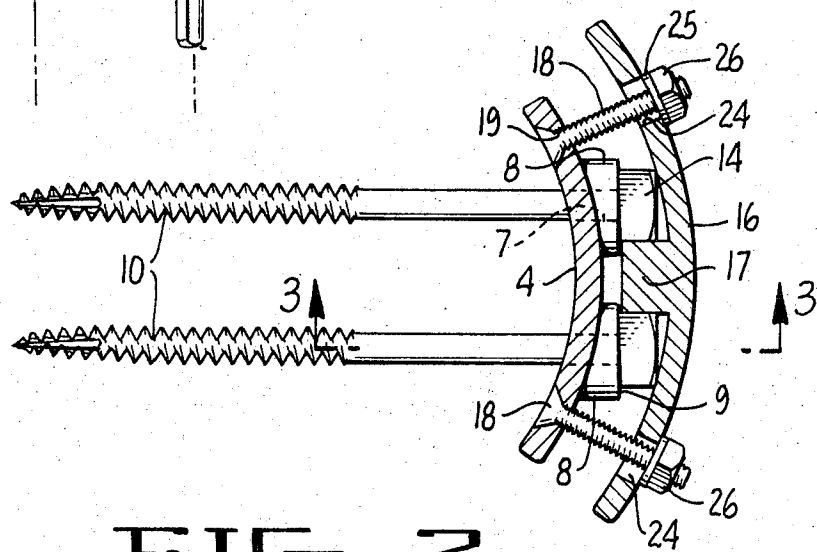

FIG. 2.

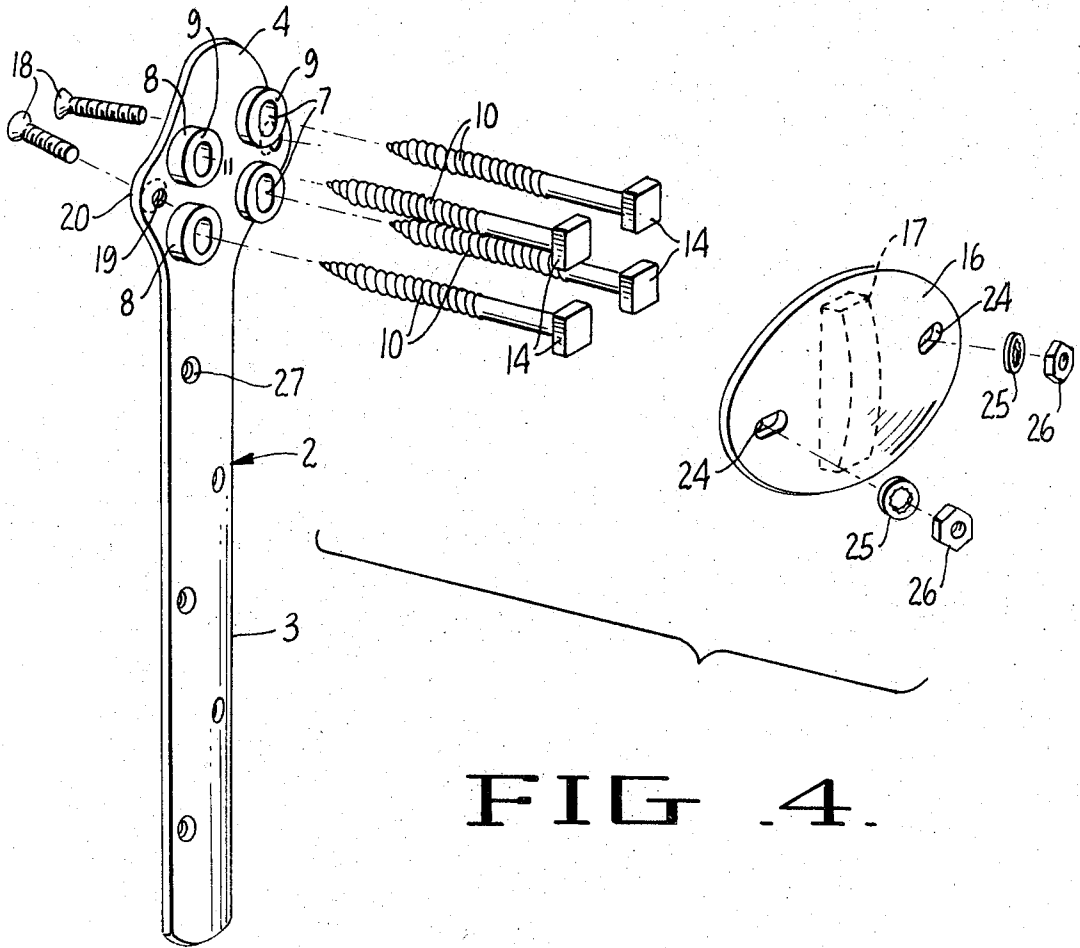

FIG. 4.

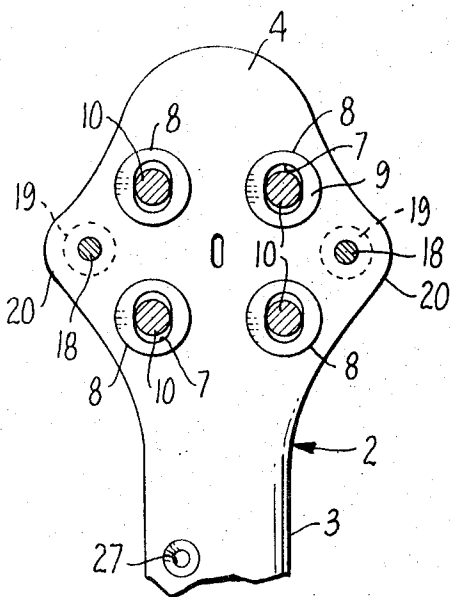

FIG. 5.

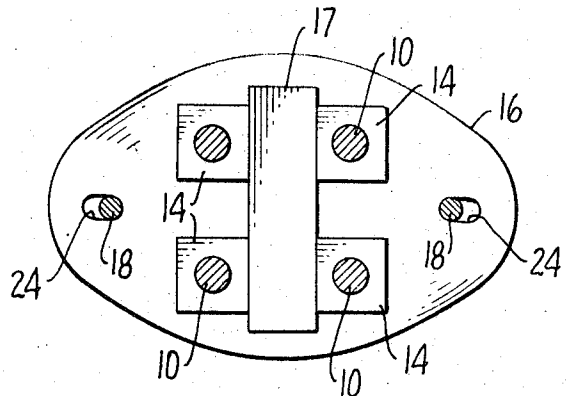

FIG. 6.

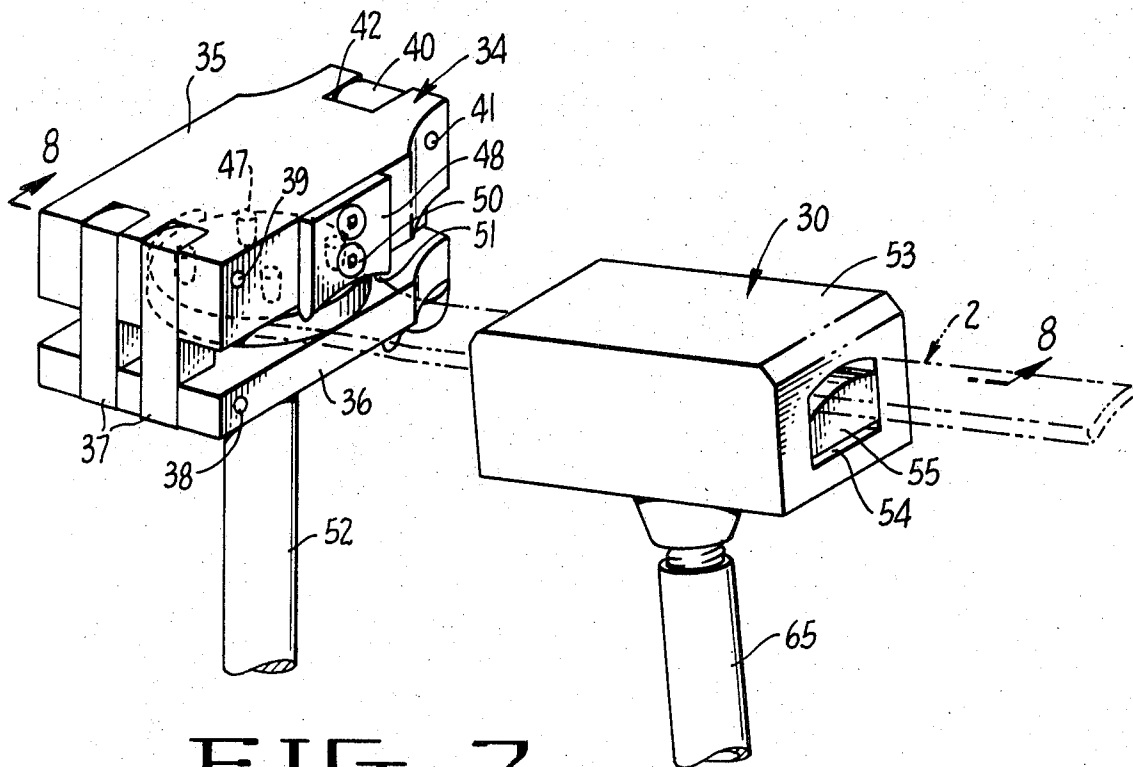

FIG. 7.

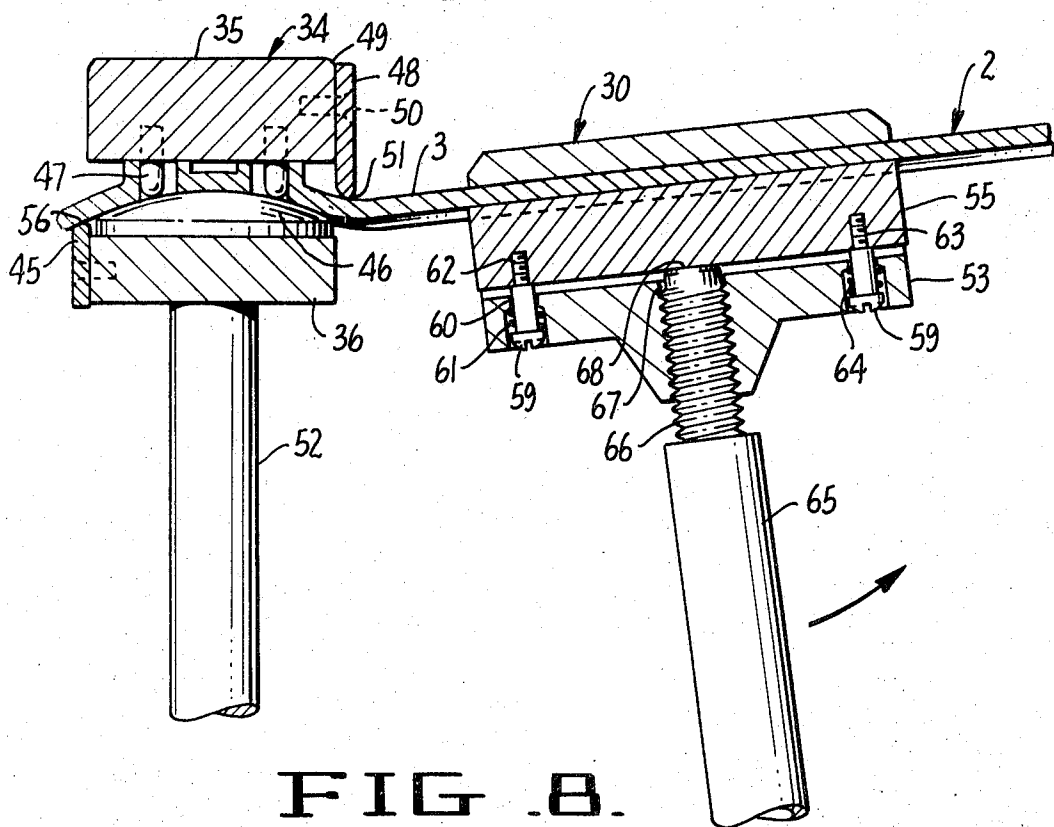
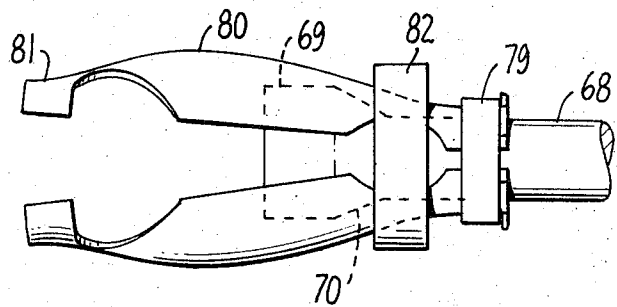
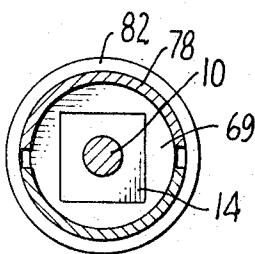
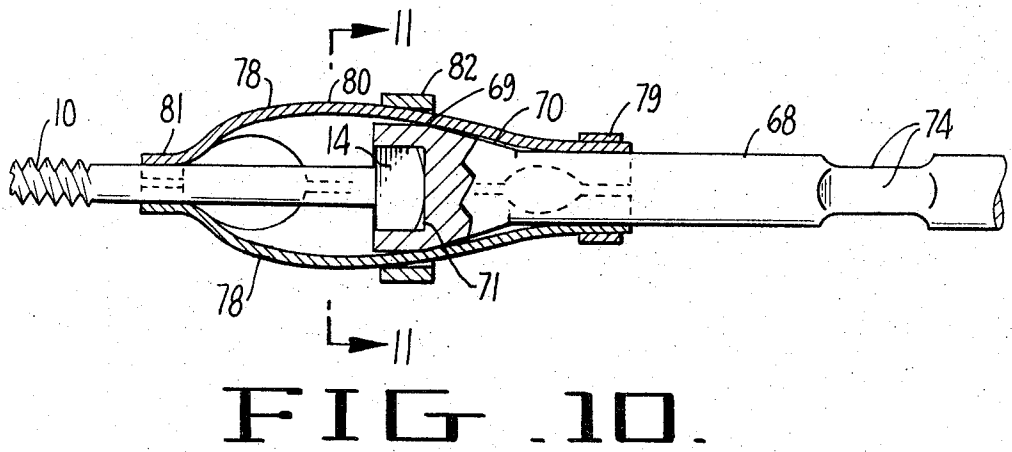
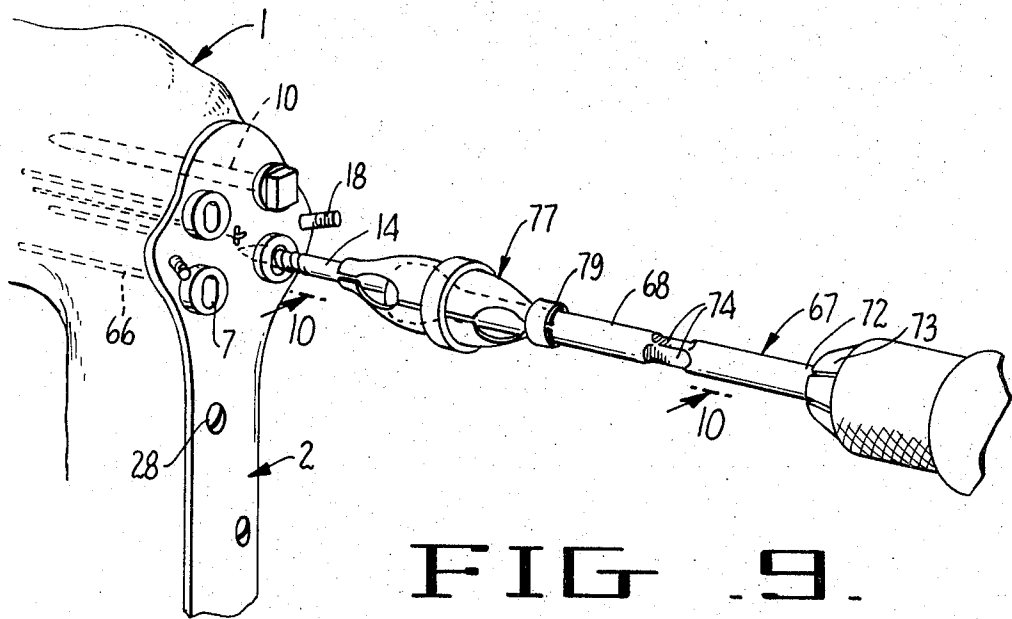

FIG. 8.



## HIP FIXATION DEVICE

## BACKGROUND OF THE INVENTION

## 1. Field of the Invention

This invention relates to a hip fixation device and tools which are used to conform and affix that device to a femur.

## 2. Description of the Prior Art

A great variety of plates, nails, pins, screws and combinations thereof are presently used in performing reconstructions of fractures of the upper end of the femur. In general the presently used plates extend along the upper portion of the shaft and curve up and around a portion of the greater trochanter. They have a plurality of transverse bores through which bone screws are screwed into the shaft and upper end of the femur. The screws which extend into the upper end of the femur are skewed relative to each other because of the curvature of the plate about the greater trochanter. Such skewed fixation is less desirable than fixation along several lines parallel to the long axis of the femur head. It is believed that the only devices which permit fixation along such parallel lines are pins and nails which are inserted independently of each other and have no associated plate.

All of the prior art fixation elements which are screwed or driven into the upper end of the femur are susceptible to loosening or backing out which weakens or, in chronic instances, totally destroys the fixation.

## SUMMARY OF THE INVENTION

The present invention is a novel hip fixation device for use in reconstructing fractures of the upper end of the femur which permits fixation along a plurality of lines parallel to the long axis of the femur head and inherently prevents the fixation elements from loosening from or backing out of the upper end of the femur. It comprises a spoon-shaped plate having an elongated handle portion which extends along the upper portion of the femur shaft and a bowl portion which is shaped to conform to the lower portion of the greater trochanter. The bowl portion of the plate has a plurality of spaced bores, preferably four in a rectangular configuration, extending transversely through it for receiving the fixation elements. The outer opening of each bore has a boss surrounding it. The heads of the bosses are flat and parallel to each other so that when the heads of the fixation elements are driven into the femur flush to the heads of the bosses, the shanks of the elements will be parallel to each other. The device also includes a cover plate which is placed over the outer side of the bowl portion of the spoon-shaped plate and means for attaching it tightly thereover so as to exert positive compression on the heads of the fixation elements to prevent them from loosening from the femur. The inside of the cover plate has a raised section which fits between the heads of the fixation elements to prevent them from turning and backing out of the femur.

Additional features of the invention are a pair of bending tools which are used to bend the spoon-shaped plate so that it closely conforms to the contour of the femur and a driving tool for driving the fixation elements into the upper end of the femur.

## BRIEF DESCRIPTION OF THE DRAWINGS

In the drawings FIGS. 1-6 illustrate an embodiment

of the device of this invention and FIGS. 7-12 illustrate tools which are used to affix said device to a femur. Specifically:

FIG. 1 is a dimetric view of a hip fixation device according to this invention attached to a femur;

FIG. 2 is an enlarged sectional view taken along line 2-2 of FIG. 1;

FIG. 3 is a sectional view taken along line 3-3 of FIG. 2;

FIG. 4 is an exploded, enlarged view of the hip fixation device shown in FIG. 1;

FIG. 5 is a sectional view taken along line 5-5 of FIG. 3;

FIG. 6 is a sectional view taken along line 6-6 of FIG. 3;

FIG. 7 is a dimetric view of a bending tool being used to bend the hip fixation device of FIG. 1;

FIG. 8 is a sectional view taken along line 8-8 of FIG. 7;

FIG. 9 is a dimetric view of a tool used to attach the hip fixation device of FIG. 1 to a femur;

FIG. 10 is an enlarged sectional view taken along line 10-10 of FIG. 9;

FIG. 11 is a sectional view taken along line 11-11 of FIG. 10; and

FIG. 12 is an enlarged view of the head of the tool shown in FIG. 9 in position to receive a screw for affixing the hip fixation device to a femur.

## DETAILED DESCRIPTION OF EMBODIMENT SHOWN IN DRAWINGS

As seen in FIG. 1 the illustrated device is designed to accomplish an anatomical reconstruction of a fracture of the upper end of a femur, generally designated 1, such as an intracapsular, intercervical or intertrochanteric fracture. It may also be employed in femoral arthrodeses and osteotomies.

The main component of the device is a spoon-shaped plate, generally designated 2, comprising an elongated handle portion 3 and a bowl portion 4. The handle portion 3 is convexly curved so that it generally conforms to the curvature of the upper portion of shaft 5 of femur 1. The bowl portion 4 is similarly curved and angled from the handle portion so that it generally conforms to the curvature of the lower portion of the greater trochanter 6 of femur 1.

Bowl portion 4 has four equidistantly spaced, ovalar bores 7 running transversely through it. Desirably bores 7 form either a 3/4 inch square configuration or a 5/8 inch square configuration, which dimensions are, respectively, ideal for use with adult male and women or children patients. The outer opening of each of bores 7 has a boss 8 surrounding it, the head 9 of which is flat. Bores 7 receive four hip screws 10 having square heads 14 the flat undersides of which seat flush against the heads 9. As shown in FIGS. 1 through 3 hip screws 10 are adapted to extend through the upper end of femur 1 axially to the long axis of the head 15 thereof (FIG. 1) in parallel relationship to each other with their square heads 14 aligned (FIG. 6) in a square configuration.

A curved, ovalar cover plate 16 fits over the outer side of bowl portion 4 and is seated against the top sides of heads 14 of hip screws 10. The inner side of ovalar cover plate 16 has a rectangular raised section 17 (FIGS. 4 and 6) formed along its short axis which extends snugly between the opposed sides of the aligned

heads 14 of hip screws 10 (FIGS. 2, 3 and 6). When so positioned, section 17 prevents hip screws 10 from rotating. Cover plate 16 is secured to bowl portion 4 by two plow bolts 18 which are threadedly received through two countersunk, threaded bores 19 which transverse bowl portion 4 at flared sections 20 thereof. Cover plate 16 has two elongated holes 24 at opposite ends of its long axis through which bolts 18 pass. Lock washers 25 and nuts 26 are threaded onto the shafts of bolts 18. By tightening nuts 26 positive compression is exerted on the heads 14 of screws 10 thereby keeping them in place and preventing them from backing out of the femur.

The handle portion 3 of plate 2 has a plurality of countersunk bores 27 transversing it through which bone screws 28 pass for purposes of securing handle portion 3 to the shaft 5 of the femur.

The above described hip fixation device is used as follows. The surgeon first drills a guide bore into the upper end of the femur along a preselected line. (The hip is usually X-rayed at this point to make sure the line of the guide bore is proper.) A guide wire or pin is then inserted into the guide bore. Bowl section 4 of plate 2 has a central hole 29 for receiving the guide wire and plate 2 is slipped over the guide wire up against the femur. In the event the angle between handle portion 3 and bowl section 4 is not such that permits a snug fit of the plate against the shaft 5 and greater trochanter 6, plate 2 must be removed and bent. Bending tools, generally designated 30, 34 and shown in FIGS. 7 and 8, are used for this purpose.

As seen in FIGS. 7 and 8 tool 30 is adapted to grip the handle portion 3 of plate 2, whereas tool 34 is adapted to grip bowl portion 4. Bending tool 34 operates on a principal similar to that of a vise. It includes an upper jaw 35 and a lower jaw 36 pivotally interconnected at their one ends by a pair of bars 37 and pins 38, 39. Their other ends are releasably interconnected by a swing bolt 40, one end of which is journalled on a pin 41 within a way 42 in said other end of upper jaw 35. Lower jaw 36 has a way (not shown) in its said other end for receiving the other end of swing bolt 40. Said other end of swing bolt 40 is threaded and fitted with a wing nut and collar (not shown) which are adapted to slide under the bottom side of lower jaw 35 when it and jaw 36 are closed. The jaws 35, 36 are secured tightly together by merely tightening said wing nut.

The inner surface of lower jaw 36 has a dome shaped protrusion 46 (FIG. 8) of the same curvature as the bowl portion 4. Correspondingly the inner surface of upper jaw 36 has four spaced nipples 47 formed on it which register with bores 7 of bowl portion 4. As shown in FIG. 8 the bowl portion 4 is placed between jaws 35, 36 with the inner surface thereof against dome shaped protrusion 46. When the jaws are closed nipples 47 are slidably engaged within bores 7. In this manner said bowl portion is held firmly between the jaws.

Upper jaw 35 has an anvil plate 48 mounted on its side adjacent the location at which handle portion 3 emerges from between the jaws. Screws 50 secure plate 48 to said side. The lower edge 51 of plate 50 has the same curvature as handle portion 3 and is adapted to engage handle portion 3 at the point at which it joins bowl portion 4. A second anvil plate 45 is mounted on lower jaw 36 at the side opposite anvil plate 48 for bending of plate 2 when it is positioned in tool 34 with

handle portion 3 extending in the direction opposite that shown in FIGS. 7 and 8. The upper edge 56 of anvil plate 45 is convexly curved so as to engage the concave surface of handle portion 3 at the point of its juncture with bowl portion 4.

Lower jaw 36 has a handle 52 attached to its bottom surface.

Bending tool 30 operates similarly to a positive, lock action compression wrench. It comprises a generally rectangular housing 53 having a longitudinal channel 54 extending through its entire length. The surface defining the upper side of channel 54 has the same curvature as handle portion 3. Otherwise channel 54 is rectangular. Disposed within channel 54 is a jaw member 55 adapted for vertical movement within channel 54. The top side of jaw member 55 also has the same curvature as handle portion 3 and is spaced from said surface defining the upper side of channel 54. Otherwise, it too is rectangular. A pair of screws 59 interconnect housing 53 and jaw member 55. As shown in FIG. 8 screws 59 are received through bores 60 and counterbores 61 which combined extend from the bottom of housing 53 through to channel 54. Screws 59 have decreased diameter, threaded end portions 62 which are screw threadedly received within bores 63 in the bottom of jaw member 59. A compression spring 64 is seated within each counterbore 61, one end of which bears on the shoulder of the counterbore and the other end of which bears on the bottom of the head of screw 59.

Tool 30 is equipped with a handle 65 having a threaded end 66 (FIG. 8). Threaded end 66 is screw threadedly received within a threaded bore 67 located in the center of the bottom of housing 53 and opening through said bottom to the channel 54. End 66 has a flat head 68 which is adapted to bear against the bottom of jaw member 55. Jaw member 55 is raised and lowered within channel 54 by turning handle 65. By tightening handle 65 head 68 is moved upwardly against the bottom of jaw member 55. Further tightening forces member 55 upwardly within channel 54. When handle 65 is backed off the weight of jaw member 55 and compression springs 64 force member 55 downwardly in channel 54.

Plate 2 is bent by locking bowl portion 4 within tool 34 and inserting handle portion 3 longitudinally through the space in channel 54 between the curved top of jaw member 55 and the curved surface defining the upper side of channel 54 and tightening handle 65. Such tightening forces jaw member 55 up against handle portion 3 thereby locking it within channel 54. Handles 52 and 65 are then gripped and pulled in opposite directions thereby forcing the joint between handle portion 3 and bowl portion 4 against the lower edge 51 of anvil plate 50 and bending said joint thereagainst.

After plate 2 is bent to conform to the femur it is replaced over the guide wire as described above. Using bores 7 and the guide wire as guides four parallel holes 66 (FIG. 9) are drilled with a bone drill in the upper end of the femur. These holes are for the purpose of starting hip screws 10. Hip screws 14 may be screwed into the femur and driven home with a screw driver, generally designated 67 and shown partially in FIGS. 9 through 12. Screw driver 67 comprises a shaft 68 having an end 69 which is flared at 70 and has a box socket 71 in it for receiving head 14 of hip screw 10. The other end 72 of shaft 68 is adapted to fit into a chuck 73 of a conventional drill or screw driver handle. At a point

along shaft 68 a series of four skived surfaces 74 are formed to define a rectangular cross-section. The rectangle so defined is in alignment with the surfaces of box socket 71 so that the surfaces may be used to ascertain the position of heads 14 of hip screws 10 for assuring correct seating of the heads with respect to cover plate 16. A tempered steel spring retainer collar, generally designated 77, fits around end 69. Collar 77 comprises a pair of clamping prongs 78 which are slidably secured at one end about shaft 68 by means of a collar 79. Each prong 78 has a bowed central section 80 which extends out around the flaring 70 on end 69 and a semicircular nipper 81 at its other end.

FIG. 12 shows retainer collar 77 in a retracted position with the driver ready to receive a screw 10. As shown the clamping prongs 78 are slightly spread apart due to their inherent spring tension. FIGS. 10 and 11 show the retainer collar 77 in its operative position, holding a screw 10 in place within socket 71 of driver 67. As shown the head 14 of screw 10 is secured within socket 71 and prongs 78 are clamped together snugly about end 69 with nippers 81 gripping the shaft of screw 10. Prongs 78 are held clamped together by a collar 78 which is slid about bowed section 80.

As shown in FIG. 9 after the screw 10 is inserted into the driver 67 and the retainer collar is slid into its operative position with collar 82 about bowed section 80 the screw 10 is inserted through a bore 7 in plate 2 into the corresponding start hole 66 and screwed into the femur. After the screw has been screwed in up to the nippers 81 the collar 82 is slid off bowed section 80, causing the prongs 78 to spread and the retainer collar is slid back on shaft 68 exposing the remainder of the screw 10. Screw 10 is then driven home with its head 14 aligned with the heads of the other screws 10 as described above. The cover plate 16 is then put into position and tightened down as described above.

The fixation is finished by screwing bone screws 28 through holes 27 into the shaft 5 of the femur.

Thus, the fixation device of this invention provides fixation along a multiplicity of parallel lines extending through the upper end of the femur in which the primary fixation elements, i.e. the hip screws, are held within the upper end of the femur under positive compression and in a manner which prevents them from backing out of the femur and weakening or even destroying the fixation.

Various modifications of the above described hip fixation device and tools may be made without departing from the spirit or scope of the invention. Means other than said flat-headed bosses, such as a single continuous flat plate surface, might be used to ensure that the hip screws remain parallel within the femur. Also, the undersides of the screw heads might be appropriately contoured or the bores in the bowl portion might have contoured counterbores. Likewise, means other than bolts and nuts might be used to attach the cover plate to the spoon-shaped plate. Further, the raised section which keeps the hip screws from rotating could be independent of the cover plate and separately attachable to the spoon-shaped plate. These modifications and other modifications which are obvious to one of ordinary skill in the mechanical arts are intended to be within the scope of the following claims.

I claim:

1. A hip fixation device comprising:

- a. a spoon-shaped plate comprising an elongated handle portion adapted to extend laterally along and conform to the upper portion of the shaft of a femur and a bowl portion adapted to conform to the lower portion of the greater trochanter of said femur;
  - b. a plurality of spaced bores transversing the bowl portion said bores being adapted to receive hip screws therethrough in substantially parallel relationship to each other;
  - c. a flat plate surface surrounding the outer opening of each of the bores, against which the heads of the hip screws are adapted to seat;
  - d. a cover plate adapted to be attached over the outer side of the bowl portion and against the heads of said hip screws;
  - e. a raised portion on the inner side of the cover plate adapted to fit between the heads of said hip screws and prevent rotation thereof; and
  - f. means for attaching the cover plate over the outer side of the bowl portion whereby pressure is exerted against the heads of the screws to keep them from loosening from the femur.
2. The hip fixation device according to claim 1 in which the handle portion has a plurality of bores transversing it for receiving bone screws therethrough.
3. The hip fixation device of claim 1 including:
- g. a boss surrounding the outer opening of each of the bores, against which the heads of the hip screws are adapted to seat.
4. The hip fixation device according to claim 1 in which there are four of said bores in a square configuration sized to the dimensions of the neck of said femur.
5. The hip fixation device according to claim 1 wherein said raised portion is a vertical, generally rectangular bar.
6. The hip fixation device according to claim 1 wherein said means for attaching the cover plate over the outer side of the bowl portion includes:
- g. a pair of bolts adapted to be received through said bowl portion and cover plate; and
  - h. a pair of nuts adapted to be screw threadedly received on the shanks of said bolts.
7. The hip fixation device according to claim 3 in which said bores are oval and the tops of the bosses are planar whereby the substantially parallel relationship of the hip screws is permitted and maintained.
8. A hip fixation device comprising:
- a. a spoon-shaped plate comprising an elongated handle portion adapted to extend laterally along and conform to the upper portion of the shaft of a femur and a bowl portion adapted to conform to the lower portion of the greater trochanter of the femur;
  - b. four oval bores transversing said bowl portion said bores being in a square configuration sized to the dimensions of the neck of said femur and being adapted to receive hip screws therethrough in substantially parallel relationship to each other;
  - c. a boss surrounding the outer opening of each of said bores, the tops of said bosses being flat and planar and against which the heads of the hip screws are adapted to seat whereby said substantially parallel relationship is maintained;



7

- d. a cover plate adapted to be attached over the outer side of the bowl portion and against the heads of said hip screws;
- e. a vertical bar on the inner side of said cover plate adapted to fit between the heads of the hip screws and prevent rotation thereof; 5
- f. a plurality of bolts adapted to be received through said bowl portion and cover plate; and
- g. a plurality of nuts adapted to be screw threadedly

8

received on the shanks of said bolts whereby said cover plate is secured to said bowl portion and pressure is exerted against the heads of said hip screws to keep them from loosening from the femur.

9. The hip fixation device according to claim 8 in which the handle portion has a plurality of bores transversing it for receiving bone screws therethrough.

\* \* \* \* \*

10

15

20

25

30

35

40

45

50

55

60

65