

June 24, 1930.

K. E. SCHUBERT
AUTOMATIC WINDOW CLEANER

1,766,550

Filed March 2, 1929

3 Sheets-Sheet 1

Fig. 1

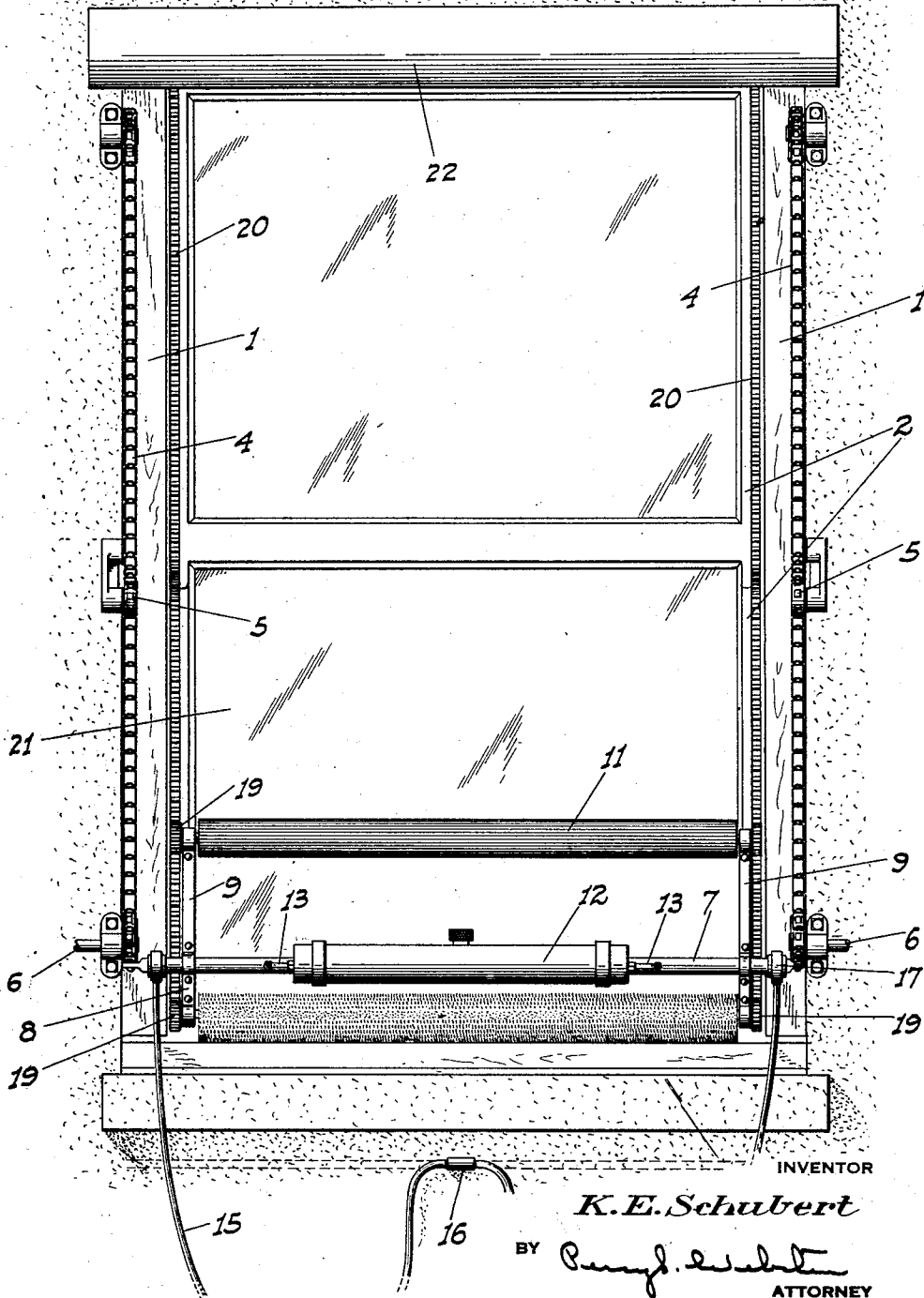

June 24, 1930.

K. E. SCHUBERT

1,766,550

AUTOMATIC WINDOW CLEANER

Filed March 2, 1929

3 Sheets-Sheet 2

Fig. 2

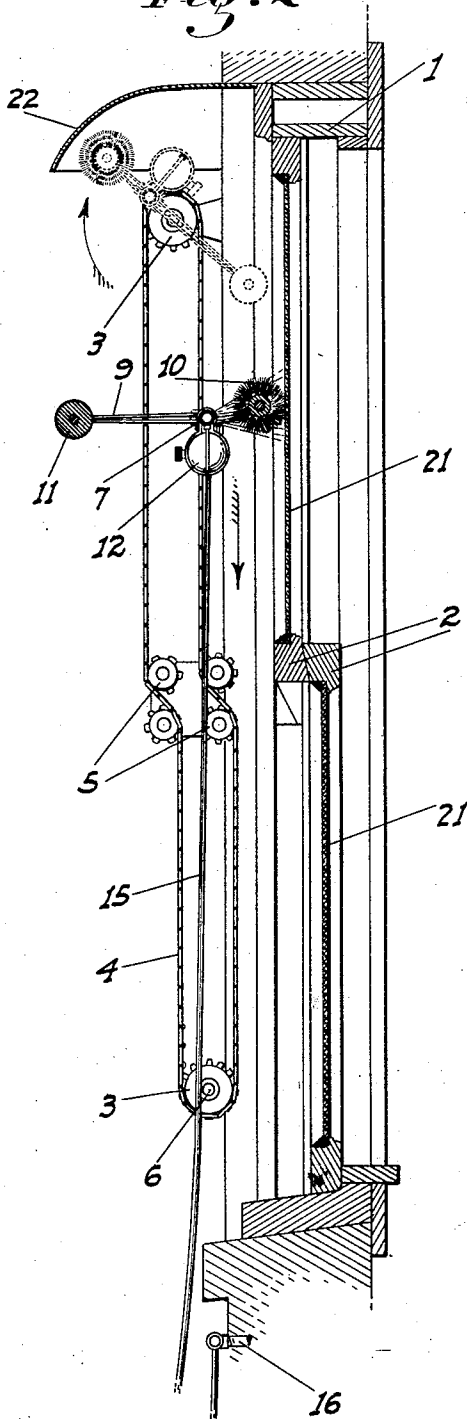
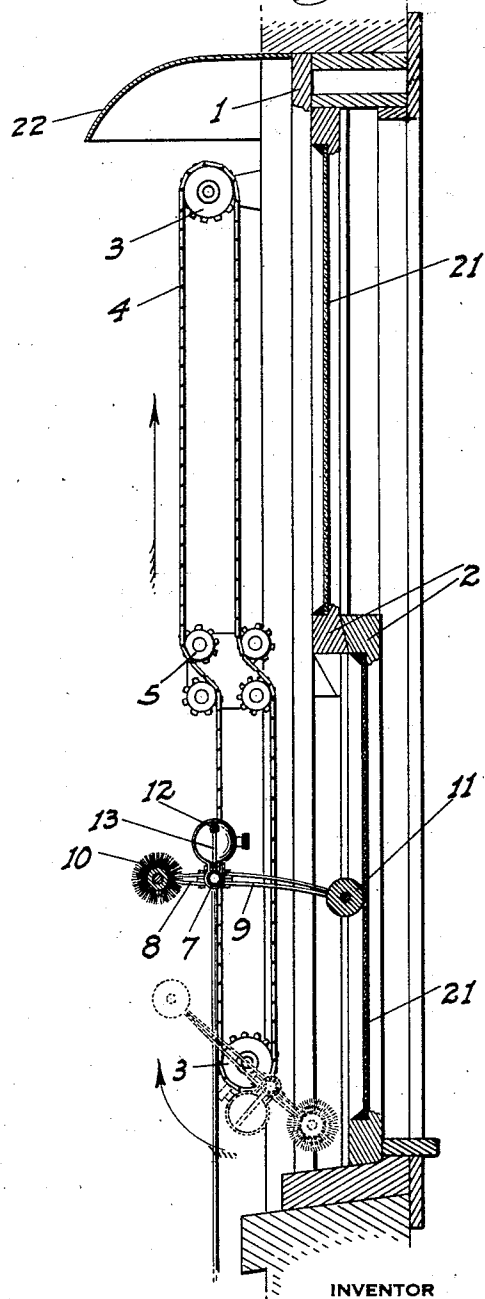

Fig. 3



INVENTOR

K. E. Schubert

BY

K. E. Schubert

ATTORNEY

June 24, 1930.

K. E. SCHUBERT

1,766,550

AUTOMATIC WINDOW CLEANER

Filed March 2, 1929

3 Sheets-Sheet 3

Fig. 4

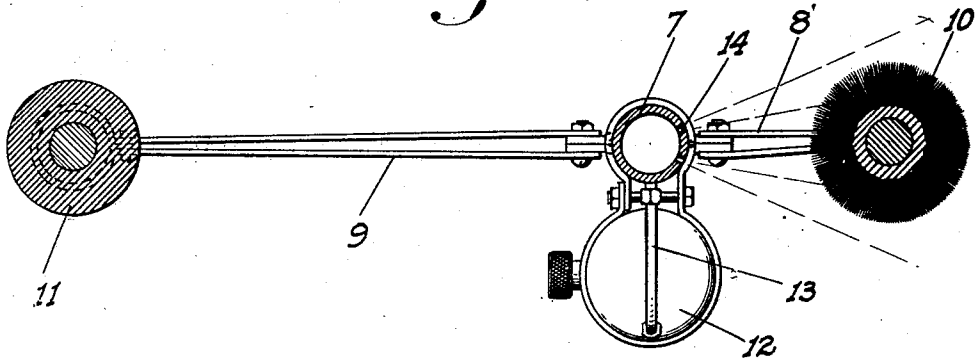

Fig. 5

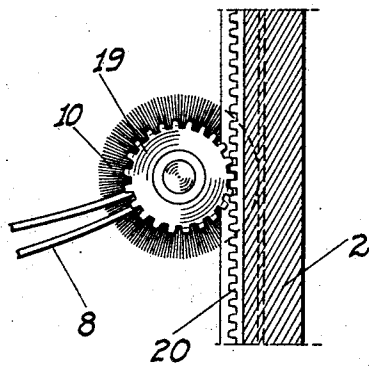
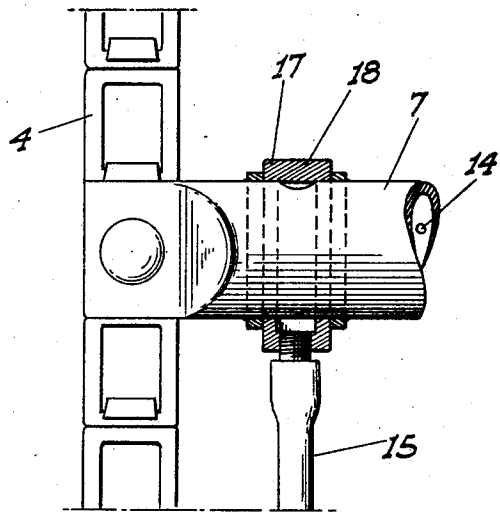

Fig. 6



INVENTOR

K. E. Schubert

BY *Henry J. White*
ATTORNEY

UNITED STATES PATENT OFFICE

KURT E. SCHUBERT, OF SUSANVILLE, CALIFORNIA, ASSIGNOR OF ONE-HALF TO ALMA ADELE LINDQUIST, OF SUSANVILLE, CALIFORNIA

AUTOMATIC WINDOW CLEANER

Application filed March 2, 1929. Serial No. 344,088.

This invention relates to window cleaning devices, and especially to one for offices, hotels and similar public buildings having a large number of windows of the same size and on the same levels.

The principal object of my invention is to provide a cleaning apparatus adapted to be permanently installed in connection with each window whereby all the windows in the building, or at least those on each floor, may be cleaned at the same time. Not only therefore are window washing operations considerably expedited over present methods, but the labor cost is largely eliminated, since all the apparatus would be under the control of the janitor of the building, who would be the only person necessary in connection with the washing operations.

These objects I accomplish by means of such structure and relative arrangement of parts as will fully appear by a perusal of the following specification and claims.

In the drawings similar characters of reference indicate corresponding parts in the several views:

Fig. 1 is an outside elevation of a window showing my window cleaning apparatus applied in connection therewith.

Fig. 2 is a cross section of the window and cleaning apparatus showing the window cleaning and washing element in operation.

Fig. 3 is a similar view showing the drying element in operation.

Fig. 4 is an enlarged sectional view of the cleaning and drying unit.

Fig. 5 is a fragmentary end view of the cleaning element showing the means for rotating the same when engaged with a window.

Fig. 6 is a fragmentary view showing the connection of an air hose with the spray pipe.

Referring now more particularly to the characters of reference on the drawings, the numeral 1 denotes a window casing of standard type in which the upper and the lower window frames 2 are slidable, said frames being offset relative to each other as usual.

Mounted on the building to the sides of the casing adjacent the top and bottom

thereof are sprocket wheels 3 about which endless chains 4 pass. The upper sprockets are somewhat further out than the lower ones in order to compensate for the offsetting of the window frames. The chains between the sprockets extend parallel to the respective frames, being shifted from the transverse vertical plane of the upper sprockets to that of the lower sprockets by suitable idlers 5 mounted in connection with the casing or building. The lower sprockets have horizontal shafts 6 attached thereto which are attempted to be driven by electric motors or other suitable means at some central point in the building or elsewhere, as may be convenient, and which it is not necessary to show.

A rigid pipe 7 extends between the chains, being closed on its ends and being rigidly connected to corresponding links of said chains. Clamped on said pipe adjacent its ends are arm units each comprising relatively long and short arms 8 and 9 respectively extending radially of the pipe in diametrically opposed relation to each other. These arms are preferably of flexible material so arranged that they can flex at their outer ends from radial lines. Turnably mounted on and extending between the short arms is a cylindrical brush 10, while mounted on and extending between the long arms is a rubber roller 11.

A cylindrical water tank 12 extends parallel to the pipe 7 and is clamped onto the same. Small pipes 13 connect the ends of the tank with the pipe 7, which has rows of spray holes 14 cut in the side thereof facing the brush 10, as shown in Fig. 4. Flexible air hoses 15 are connected at their lower ends to a pipe 16 adapted to be connected to a suitable source of compressed air; said hoses at their upper ends being connected to collars 17 turnably mounted on the pipe 16 adjacent its ends and with an air-tight fit.

Said pipe 7 under the collars 17 is provided with openings 18 so positioned that compressed air from the hoses can enter said pipe only when the latter is turned, with the movement of the chains, so that the brush engages the window.

55

60

65

70

75

80

85

90

95

100

Fixed in connection with the brush and roller beyond the supporting arms are spur pinions 19, of smaller diameter than said brush and roller and which are positioned to mesh with racks 20 extending from top to bottom of and countersunk in the sides of the window frame.

In operation the chains are driven so that their inner runs move down; the brush 10 as the pipe 7 passes about the upper sprocket wheels engaging the upper window pane 21 and moving down the same. At the same time the brush constantly rotates owing to the engagement of its pinions with the window frame racks. The pipe 7 is then positioned so that the compressed air may enter the same from the hoses and the water tank and its end pipes 13 are so positioned that a small amount of water will then be drawn from the tank and into the pipe 7 by the action of air blowing through said pipe. This water in the form of a fine spray is blown through the openings 14 onto the brush and toward the window, causing said brush as it descends to wash the window. When moving from the upper to the lower window the brush must pass over the lower rail of the window frame of said upper window before it can engage the lower pane. The resilient nature of the brush supporting arms permits this to be done without unduly straining the chains or other parts. Also during this movement of the brush the pinions leave the racks, since the brush is of greater diameter than said pinions. The brush however when dropping into place against the pane of the lower window will again enable the pinions to engage the corresponding racks so as to keep the brush turning as it descends.

On the arrival of the inner runs of the chains at the lower sprockets they pass about the same and in so doing the pipe 7 and parts secured thereto are given a half turn, as will be evident. The brush is then turned to face away from the window while the rubber drying roller engages the pane and rotates as the outer runs of the chains move upwardly. Here again the resilient or flexible nature of the roller supporting arms enables said roller to pass from the lower to the upper window without any undue strain being placed on the parts. In this position of the pipe 7 the tank 12 is inverted from its previous setting and the openings 18 are shut off from communication with the air hoses. No air can then enter the separate pipe nor will any water from the tank pass into the same, since the pipes 13 now communicate with said tank at the bottom thereof and above the water level.

Upon reaching the top sprockets the half turn of the pipe 7 and the parts secured thereto again occurs, again causing the

brush 10 to be moved into contact with the upper window. If necessary another cleaning and drying cycle may then be carried out but if the window has been cleaned sufficiently the cleaning and drying units are halted at the top where they are covered and protected by a hood 22 projecting outwardly from the top of the window area.

From the foregoing description it will be readily seen that I have produced such a device as substantially fulfills the objects of the invention as set forth herein.

While this specification sets forth in detail the present and preferred construction of the device, still in practice such deviations from such detail may be resorted to as do not form a departure from the spirit of the invention, as defined by the appended claims.

Having thus described my invention what I claim as new and useful and desire to secure by Letters Patent is:

1. A window cleaning apparatus including a washing element to engage and traverse the window, a drying element to traverse the window, a common movable supporting structure for said elements, and means for mounting and operating said structure to cause the elements to automatically and alternately engage and traverse the window.

2. A window cleaning apparatus including top and bottom sprockets mounted at the sides of the window on horizontal axes parallel with said window, endless chains passing about said sprockets, a rigid member extending between and rigid with corresponding links of the chains, a washing element supported by said member to engage and traverse the window when said member is on the run of the chains nearest the window, and a drying element likewise supported by said member to engage and traverse the window only when said member is on the run of the chains farthest from the window.

3. A window washing apparatus including a rotary washing element, movable means mounted in connection with the window and supporting said element and arranged to cause the same to engage and traverse the window and to be then drawn away from the same, and spray means associated with the washing element and functioning only when said element is thus engaged with the window.

4. A window washing apparatus including a rotary washing element, movable means mounted in connection with the window and supporting said element and arranged to cause the same to engage and traverse the window and to be then drawn away from the same, a spray pipe mounted in connection with the element parallel thereto and disposed to throw a spray against the

element and window, a compressed air pipe connected with the spray pipe, and means between said pipes for providing communication therebetween only when the element is engaged with the window.

5 5. A window washing apparatus including a rotary washing element, movable means mounted in connection with the window and supporting said element and arranged to cause the same to engage and traverse the window and to be then drawn away from the same, a spray pipe mounted in connection with the element parallel thereto and disposed to throw a spray against the element and window, a water tank mounted in connection with the pipe and communicating therewith, a compressed air pipe connected with the spray pipe to draw water from the tank into the spray pipe and spray such water against the element, and means automatically shutting off communication between the pipes except when the element is traversing the window; the tank being disposed to allow water to enter the spray pipe only when the compressed air is active in the spray pipe.

6. A window cleaning apparatus including a washing element to engage and traverse the window, a drying element to traverse the window, a common supporting structure for said elements, means for successively causing said structure to move up and down the window, and means included with said supporting and moving means for causing the washing element to engage the window only during the up stroke of the structure, and for causing the drying element to engage the window only during the down stroke of the structure.

40 In testimony whereof I affix my signature.
KURT E. SCHUBERT.

45

50

55

60

65