



US00D961557S

(12) **United States Design Patent**
Akana et al.

(10) **Patent No.:** **US D961,557 S**
(45) **Date of Patent:** **** Aug. 23, 2022**

(54) **EARPHONE**

(71) Applicant: **Apple Inc.**, Cupertino, CA (US)

(72) Inventors: **Jody Akana**, San Francisco, CA (US); **Molly Anderson**, San Francisco, CA (US); **Bartley K. Andre**, Palo Alto, CA (US); **Shota Aoyagi**, San Francisco, CA (US); **Anthony Michael Ashcroft**, San Francisco, CA (US); **Marine C. Bataille**, San Francisco, CA (US); **Jeremy Bataillou**, San Francisco, CA (US); **Abidur Rahman Chowdhury**, San Francisco, CA (US); **Markus Diebel**, San Francisco, CA (US); **M. Evans Hankey**, San Francisco, CA (US); **Julian Hoenig**, San Francisco, CA (US); **Richard P. Howarth**, San Francisco, CA (US); **Jonathan P. Ive**, San Francisco, CA (US); **Julian Jaede**, San Francisco, CA (US); **Duncan Robert Kerr**, San Francisco, CA (US); **Peter Russell-Clarke**, San Francisco, CA (US); **Benjamin Andrew Shaffer**, San Jose, CA (US); **Sung-Ho Tan**, Vienna (AT); **Clement Tissandier**, San Francisco, CA (US); **Eugene Antony Whang**, San Francisco, CA (US); **Rico Zörkendörfer**, San Francisco, CA (US)

(73) Assignee: **Apple Inc.**, Cupertino, CA (US)

(**) Term: **15 Years**

(21) Appl. No.: **29/804,821**

(22) Filed: **Aug. 23, 2021**

Related U.S. Application Data

(63) Continuation of application No. 29/764,724, filed on Dec. 31, 2020, now Pat. No. Des. 928,745, which is a continuation of application No. 29/741,273, filed on Jul. 10, 2020, now Pat. No. Des. 907,010, which is a continuation of application No. 29/705,727, filed on

Sep. 13, 2019, now Pat. No. Des. 906,297, application No. 29/804,821, filed on Aug. 23, 2021, which is a continuation of application No. 29/741,272, filed on Jul. 10, 2020, now Pat. No. Des. 929,374, which is a continuation of application No. 29/705,727, application No. 29/804,821, filed on Aug. 23, 2021, which is a continuation of application No. 29/741,274, filed on Jul. 10, 2020, now Pat. No. Des. 928,743, which is a continuation of application No. 29/705,727.

(51) **LOC (13) Cl.** **14-01**

(52) **U.S. Cl.**
USPC **D14/223**

(58) **Field of Classification Search**

USPC D14/223, 205; D24/174; 128/864, 865, 128/866; 381/380, 381, 322-324; 455/90.3, 575.1, 569.1
CPC H04R 1/10; H04R 25/00; H04R 25/02; H04R 1/1016; H04R 1/1066; H04R 5/033; H04R 5/0335; H04R 1/1091; H04R 1/1058; H04R 1/105; H04R 1/1083; H04R 1/02; H04R 9/06
See application file for complete search history.

(56) **References Cited**

U.S. PATENT DOCUMENTS

2,148,477 A	2/1939	Koch
2,595,489 A	5/1952	Rutter et al.
3,368,644 A	2/1968	Henderson
4,532,649 A	7/1985	Bellafiore
4,672,672 A	6/1987	Eggert et al.
4,677,675 A	6/1987	Killion et al.
4,736,430 A	4/1988	Schroder
4,965,838 A	10/1990	Kamon et al.
D331,057 S	11/1992	Isonaga
D337,118 S	7/1993	Seikita
D344,800 S	3/1994	Lamby
D353,379 S	12/1994	Nakamura et al.
5,420,935 A	5/1995	Shinohara et al.
D410,079 S	5/1999	Falco et al.
6,122,369 A	9/2000	Hwang et al.
D469,753 S	2/2003	Andre et al.
6,690,807 B1	2/2004	Meyer
D488,460 S	4/2004	Alwicker et al.
6,731,772 B1	5/2004	Byun

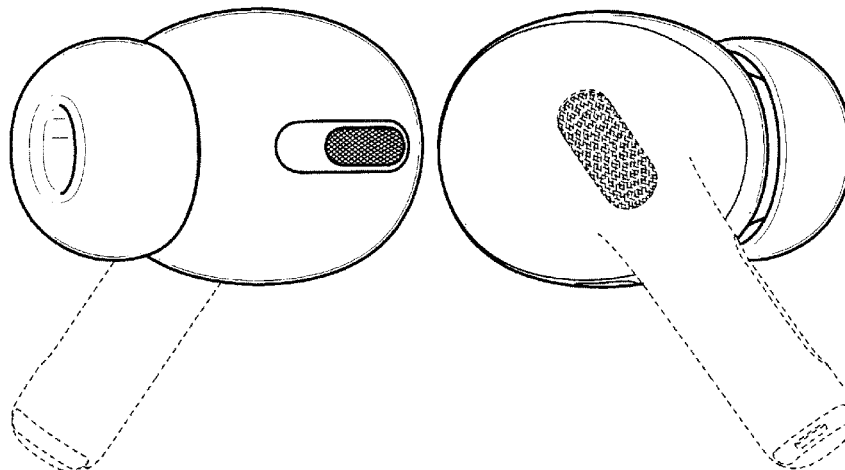

US D961,557 S

D499,397 S	12/2004	Hlas et al.	D865,720 S	11/2019	Deng et al.	
D505,132 S	5/2005	Linville et al.	D869,445 S	12/2019	Hu	
D506,744 S	6/2005	Andre et al.	D883,260 S	5/2020	Hu	
D515,070 S	2/2006	Andre et al.	D895,582 S	9/2020	Wu	
D523,846 S	6/2006	Lee	D896,206 S	9/2020	Xu	
D533,868 S	12/2006	Koizumi	D896,788 S	9/2020	Akana et al.	
D554,109 S	10/2007	Ledbetter et al.	D897,997 S	10/2020	Zhang	
D557,689 S	12/2007	Huang	D897,998 S	10/2020	Ma	
D566,687 S	4/2008	Duarte et al.	D904,351 S	12/2020	Zhang	
D568,291 S	5/2008	Andre et al.	D905,018 S	12/2020	Zhu	
D573,977 S	7/2008	Ledbetter et al.	D905,019 S	12/2020	Liu	
D575,269 S	8/2008	Ledbetter et al.	D906,297 S	12/2020	Akana et al.	
D578,518 S	10/2008	Ewert	D907,009 S	1/2021	Akana et al.	
D579,923 S	11/2008	Andre et al.	D907,010 S	1/2021	Akana et al.	
D587,677 S	3/2009	Andre et al.	D909,347 S	2/2021	Akana et al.	
D589,491 S	3/2009	Andre et al.	D910,600 S *	2/2021	Zhang	D14/223
D589,498 S	3/2009	Komiyama	D914,645 S *	3/2021	Akana	H04R 1/10
D590,375 S	4/2009	Komiyama				D14/223
D591,721 S *	5/2009	Densho	10,966,047 B1 *	3/2021	Tong	H04R 29/006
D593,537 S	6/2009	Arimoto	D916,683 S *	4/2021	Yao	D14/223
D596,616 S	7/2009	Andre et al.	D921,615 S *	6/2021	Wu	D14/223
D599,330 S	9/2009	Andre et al.	D924,209 S *	7/2021	Wu	D14/223
D601,134 S	9/2009	Elabidi et al.	D928,743 S *	8/2021	Akana	D14/223
D616,874 S	6/2010	Matsuoka	D928,745 S *	8/2021	Akana	D14/223
D618,209 S	6/2010	Andre et al.	D929,374 S *	8/2021	Akana	D14/223
D618,210 S	6/2010	Andre et al.	D929,375 S *	8/2021	Akana	D14/223
D618,219 S	6/2010	Burgett et al.	D929,376 S	8/2021	Akana et al.	
D622,265 S	8/2010	Rye	D929,377 S *	8/2021	Akana	H04R 1/1016
D626,948 S	11/2010	Nault				D14/223
D627,766 S	11/2010	Arimoto	D929,969 S *	9/2021	Ding	D3/274
D628,193 S	11/2010	Zheng	D929,972 S *	9/2021	Akana	D14/223
D632,282 S	2/2011	Kitayama	D931,838 S *	9/2021	Deng	D14/223
D633,086 S	2/2011	Chen	D934,202 S *	10/2021	Liu	D14/223
D635,960 S	4/2011	Gondo et al.	D936,637 S *	11/2021	Lai	D14/223
D639,279 S	6/2011	Andre et al.	D938,386 S *	12/2021	Park	D14/205
D652,823 S	1/2012	Chen	D943,554 S *	2/2022	Zhang	D14/223
D656,481 S	3/2012	McManigal	2010/0246879 A1	9/2010	Siahaan et al.	
D662,493 S *	6/2012	Chen	2011/0051978 A1	3/2011	Chen	
D662,495 S	6/2012	Andre et al.	2012/0003937 A1	1/2012	Zhong	
D664,523 S	7/2012	Naitou	2012/0155692 A1	6/2012	Chen	
D666,580 S	9/2012	Lee et al.	2012/0237074 A1	9/2012	Aase	
D669,058 S	10/2012	Lee et al.	2013/0004011 A1	1/2013	Hayashida et al.	
D669,453 S	10/2012	Katsuraku et al.	2013/0010998 A1	1/2013	Seo	
D674,781 S	1/2013	Sakata	2013/0343594 A1	12/2013	Howes et al.	
D675,194 S	1/2013	Andre et al.	2013/0343595 A1	12/2013	Zorkendorfer et al.	
8,345,912 B2	1/2013	Akihiko et al.	2016/0360310 A1 *	12/2016	Huang	H04R 1/24
D676,427 S	2/2013	Yang	2017/0026733 A1	1/2017	Armstrong	
8,391,533 B2 *	3/2013	Sim	2017/0201821 A1	7/2017	McAuliffe et al.	
			2018/0077481 A1	3/2018	Kim	
D681,015 S	4/2013	Akana et al.	2020/0068285 A1	2/2020	Dang et al.	
D687,419 S	8/2013	Andre et al.	2020/0107098 A1	4/2020	DiFonzo et al.	
8,515,116 B2	8/2013	Lee	2020/0245049 A1	7/2020	Karayiannis et al.	
D691,594 S	10/2013	Akana et al.	2020/0275182 A1	8/2020	Ettensberger	
D694,220 S	11/2013	Lee et al.	2020/0282856 A1	9/2020	Samojeden et al.	
D694,249 S	11/2013	Akana et al.	2021/0136478 A1 *	5/2021	Jou	H04R 1/04
D706,643 S	6/2014	Akana et al.				
D707,206 S	6/2014	Akana et al.				
8,800,712 B2	8/2014	Campbell et al.				
D712,279 S	9/2014	Akana et al.				
D718,284 S	11/2014	Shibusawa	CN	306941740	*	2/2021
D718,285 S	11/2014	Shibusawa	CN	306907292	*	10/2021
8,965,030 B2	2/2015	Aase	CN	306941764	*	11/2021
D728,533 S	5/2015	Poulsen et al.	CN	306958909	*	11/2021
D732,007 S	6/2015	Oksman et al.	EM	008534861-0001	*	5/2021
D732,008 S	6/2015	Akana et al.	EM	008669519-0001	*	9/2021
D733,101 S	6/2015	Pi et al.	IN	347883-0001	*	8/2021
D733,689 S	7/2015	Narita				
D738,864 S *	9/2015	Lee				D14/223
D741,287 S	10/2015	Harata et al.				
D747,295 S	1/2016	Eastwood et al.				
D755,759 S	5/2016	Cai				
D769,849 S	10/2016	Akana et al.				
D801,314 S	10/2017	Akana et al.				
9,961,431 B2	5/2018	McPeak et al.				
10,003,880 B2	6/2018	Wagman et al.				
D844,588 S	4/2019	Brunner et al.				
D847,125 S	4/2019	Akana et al.				
D847,780 S	5/2019	Brunner et al.				
D849,401 S	5/2019	Akana et al.				

FOREIGN PATENT DOCUMENTS

CN	306941740	*	2/2021
CN	306907292	*	10/2021
CN	306941764	*	11/2021
CN	306958909	*	11/2021
EM	008534861-0001	*	5/2021
EM	008669519-0001	*	9/2021
IN	347883-0001	*	8/2021

OTHER PUBLICATIONS

“iBlink WLP3 Earbuds—100Hz-10kHz, Noise Isolation, 3.5mm Jack, LED Light (Pink), White,” TigerDirect.com. Available at least as early as Sep. 20, 2019. Accessed at: <http://www.tigerdirect.com/applications/SearchTools/item-details.asp?EdpNo=3988300&csid=61>.

* cited by examiner

Primary Examiner — Paula Allen Greene

(74) *Attorney, Agent, or Firm* — Sterne, Kessler,
Goldstein & Fox P.L.L.C.

(57)

CLAIM

The ornamental design for an earphone, as shown and described.

DESCRIPTION

FIG. 1 is a front perspective view of an earphone showing the claimed design;

FIG. 2 is a rear perspective view thereof;

FIG. 3 is a front view thereof;

FIG. 4 is a rear view thereof;

FIG. 5 is a left side view thereof;

FIG. 6 is a right side view thereof;

FIG. 7 is a top view thereof; and,

FIG. 8 is a bottom view thereof.

The broken lines in the figures show portions of the earphone that form no part of the claimed design.

1 Claim, 4 Drawing Sheets

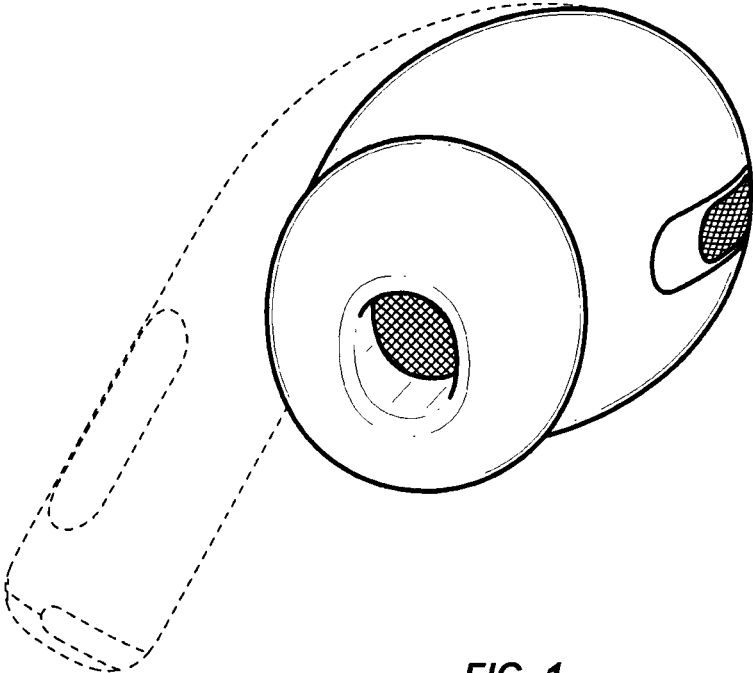

FIG. 1

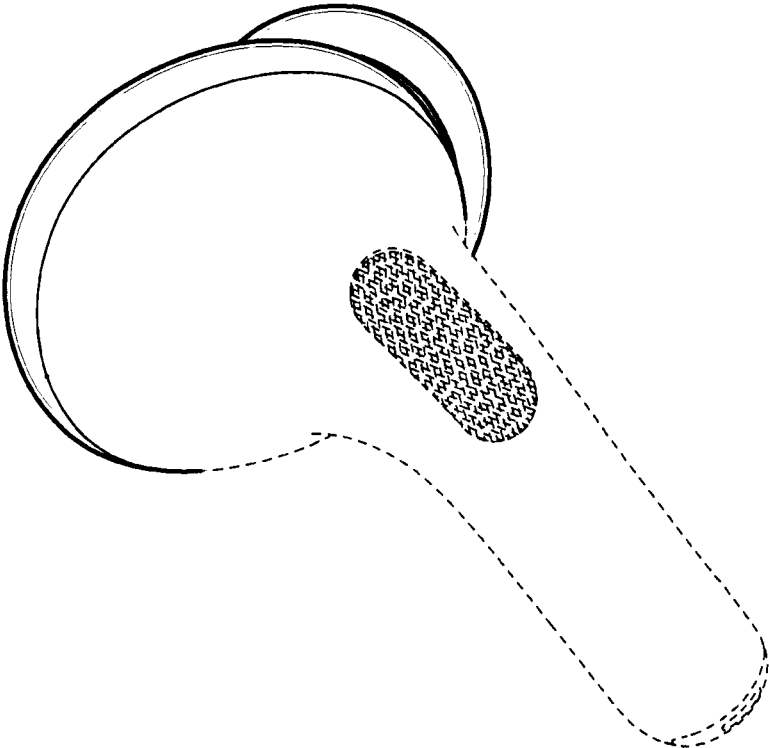

FIG. 2

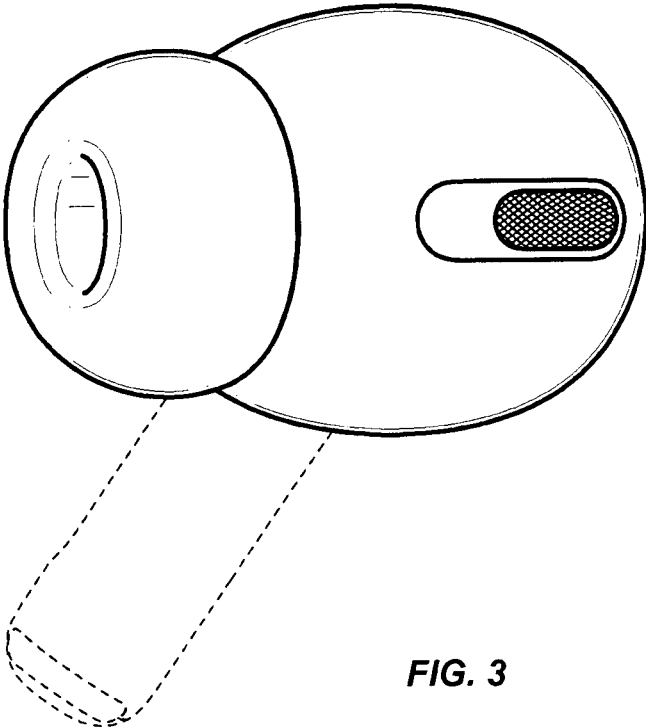

FIG. 3

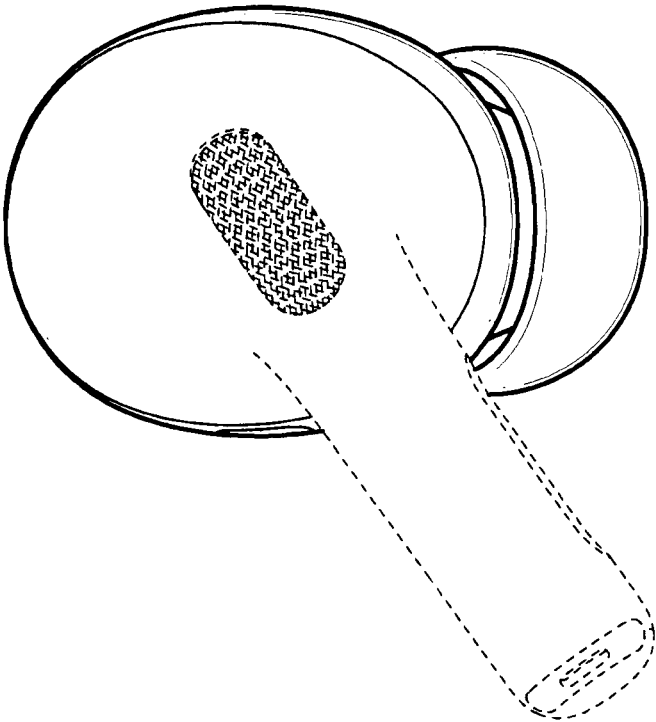

FIG. 4

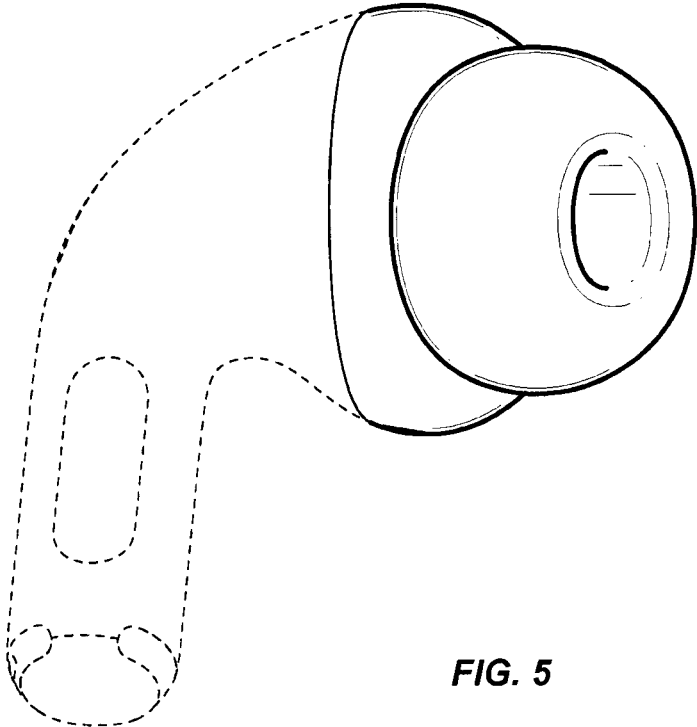

FIG. 5

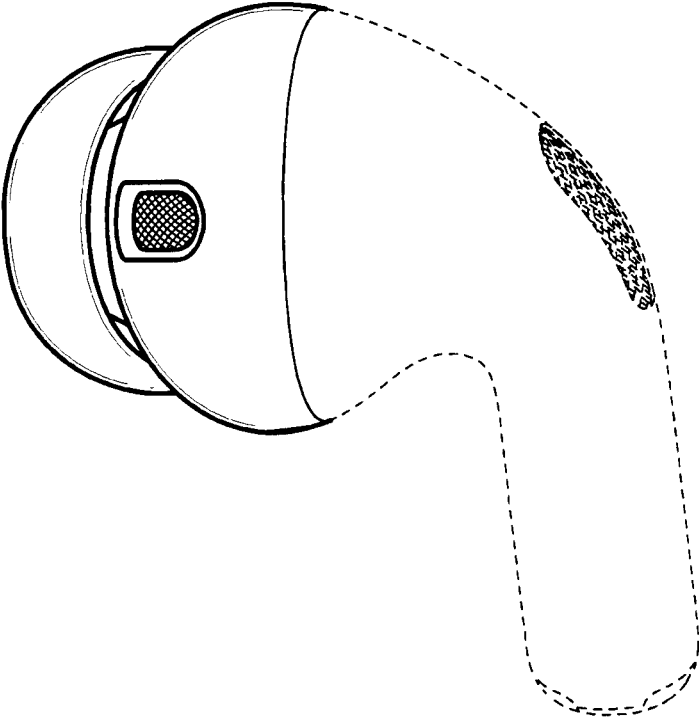

FIG. 6

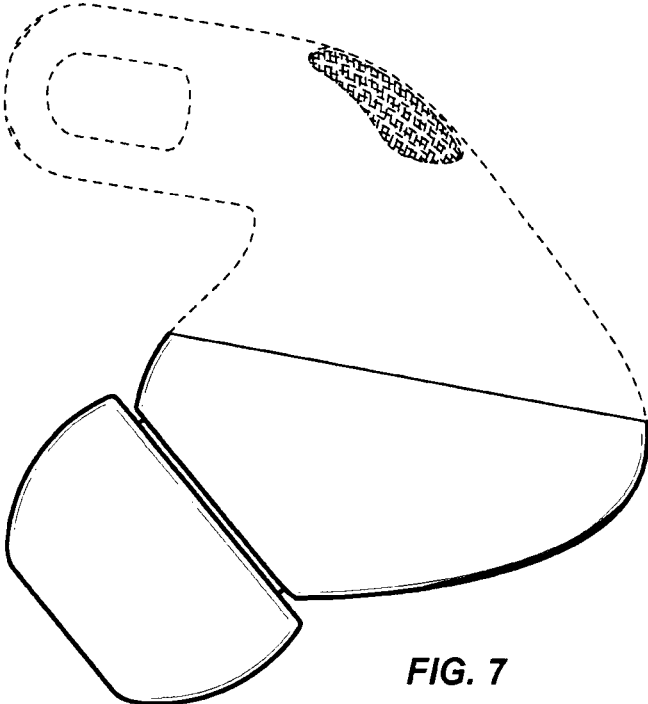

FIG. 7

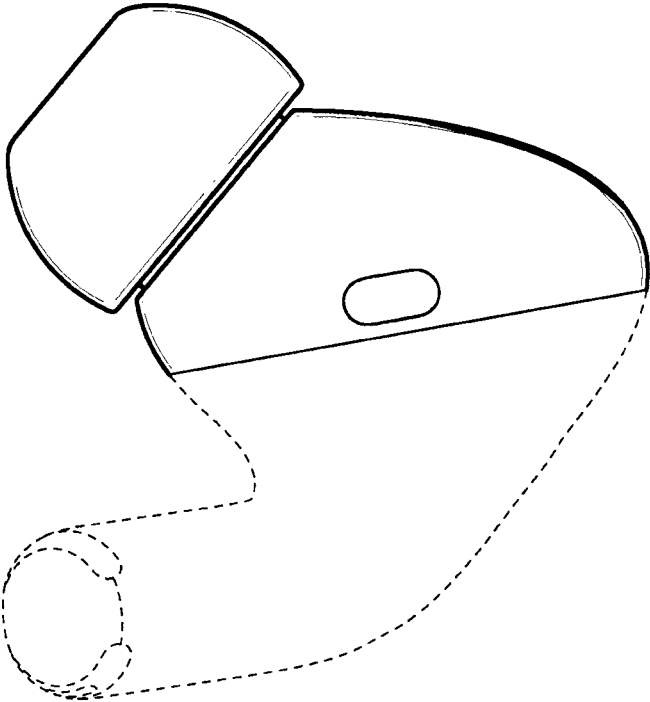

FIG. 8