



US 20020124851A1

(19) **United States**

(12) **Patent Application Publication**
Knauer et al.

(10) **Pub. No.: US 2002/0124851 A1**

(43) **Pub. Date: Sep. 12, 2002**

(54) **HEARING PROTECTIVE DEVICE AND METHOD OF MAKING SAME**

Publication Classification

(76) Inventors: **Richard Knauer**, Indianapolis, IN (US); **Alan R. Seville**, Indianapolis, IN (US); **Robert N. Falco**, Indianapolis, IN (US); **James Hall**, Lincoln, RI (US); **Lori S. Hall**, Lincoln, RI (US)

(51) **Int. Cl.⁷** **A61F 11/00**
(52) **U.S. Cl.** **128/864**

(57) **ABSTRACT**

Correspondence Address:
CANTOR COLBURN, LLP
55 GRIFFIN ROAD SOUTH
BLOOMFIELD, CT 06002

A hearing device including a foam, a foam insertable portion, a component, and a foam handle portion, and a method of forming the same. The component is nestable with and bondable with the foam such that the component is at least partially within the foam insertable portion and the foam handle portion. The hearing protective device includes ear-plugs attached to a flexible cord, under-the-chin element, or headband. A method of making a hearing protective device including disposing a component into a mold, introducing a foam or foamable mixture into the mold, causing the foam to rise such that the component is nested within and bonded with the foam.

(21) Appl. No.: **09/990,654**

(22) Filed: **Nov. 21, 2001**

Related U.S. Application Data

(60) Provisional application No. 60/253,433, filed on Nov. 28, 2000.

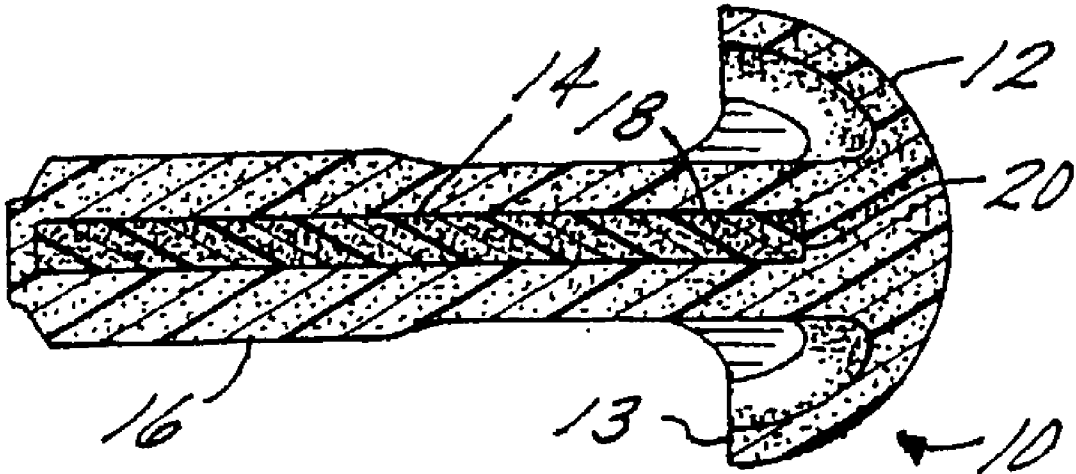

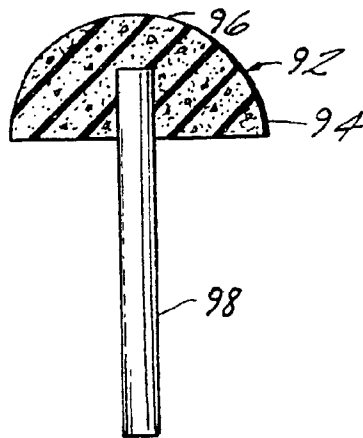

FIG. 1
(PRIOR ART)

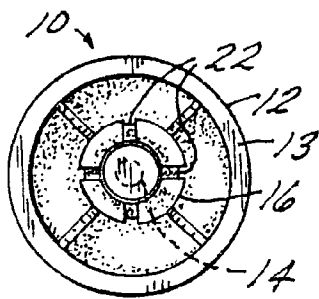

FIG. 4

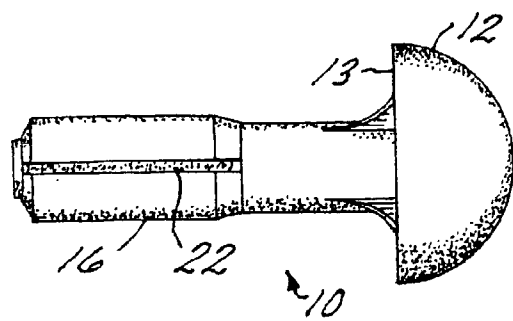

FIG. 2

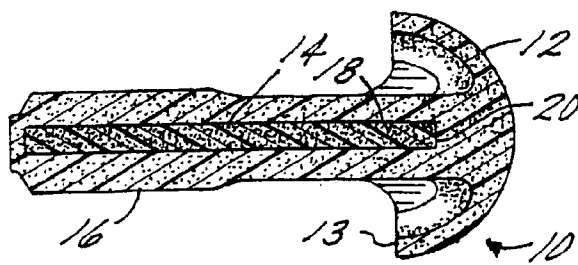

FIG. 3

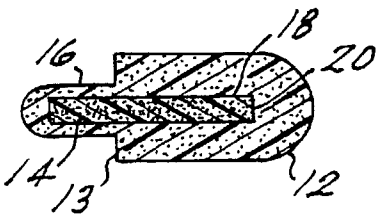

FIG. 5

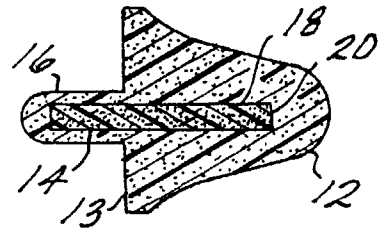

FIG. 6

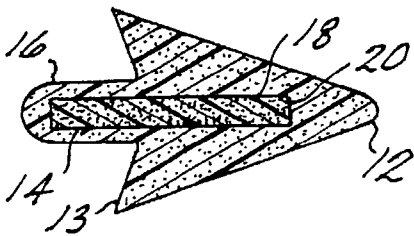

FIG. 7

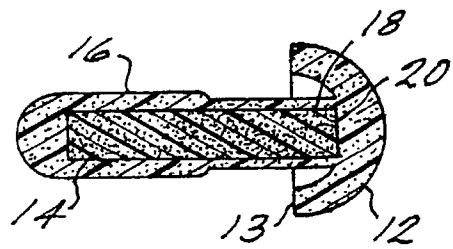

FIG. 8

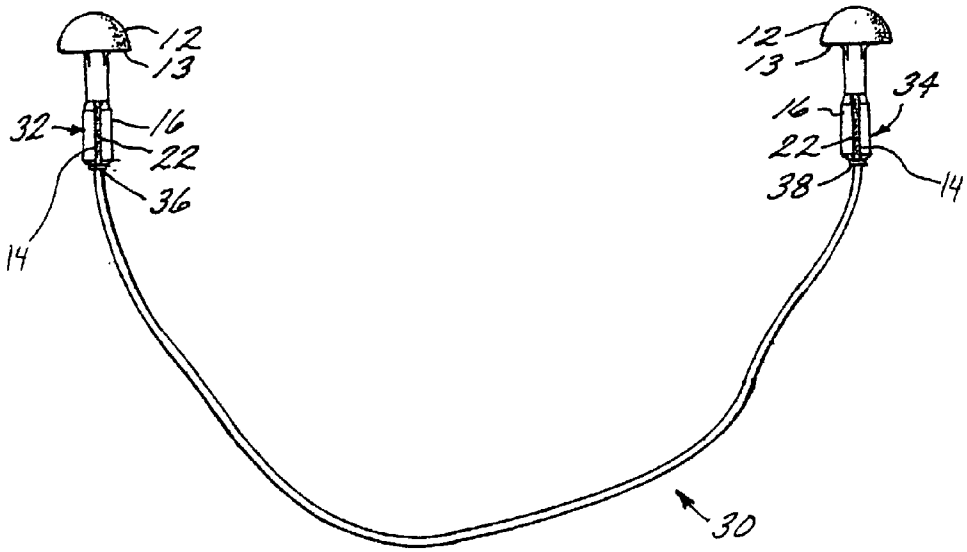

FIG. 9

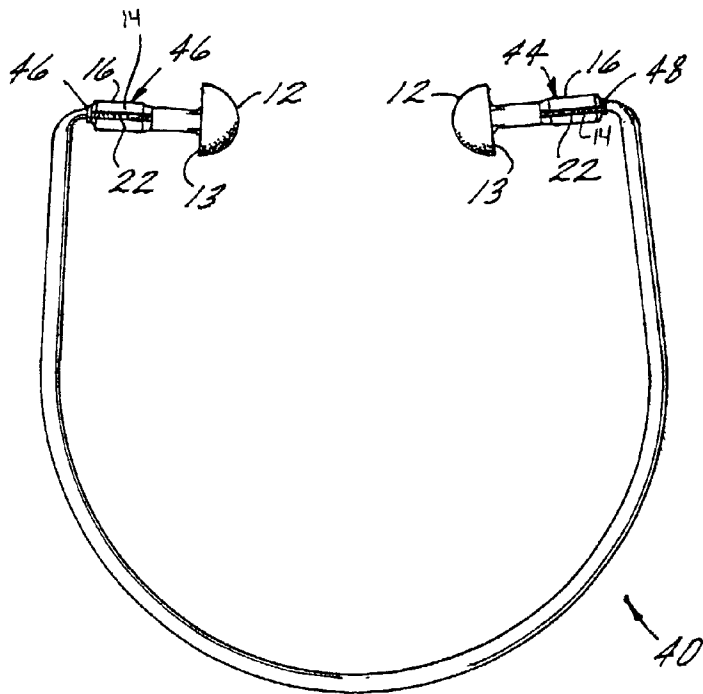

FIG. 10

FIGURE 11

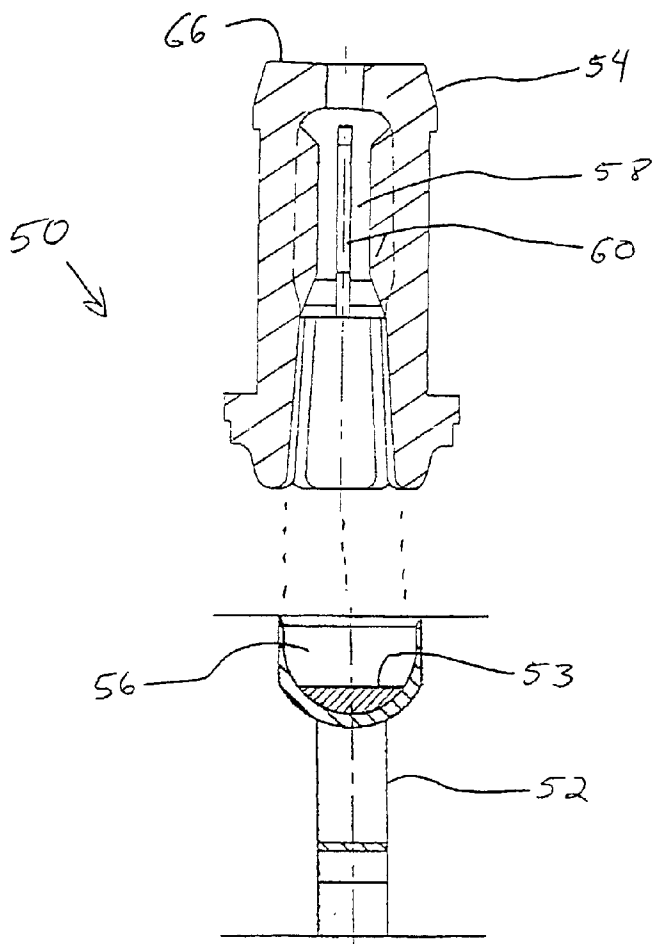

FIGURE 12

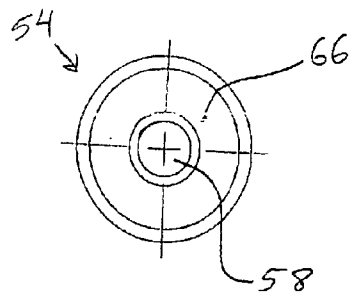

FIGURE 13A

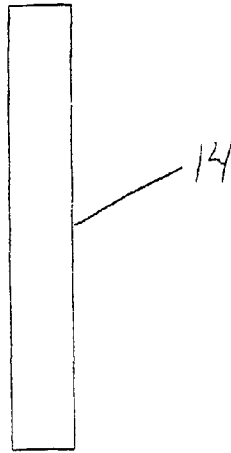

FIGURE 13B

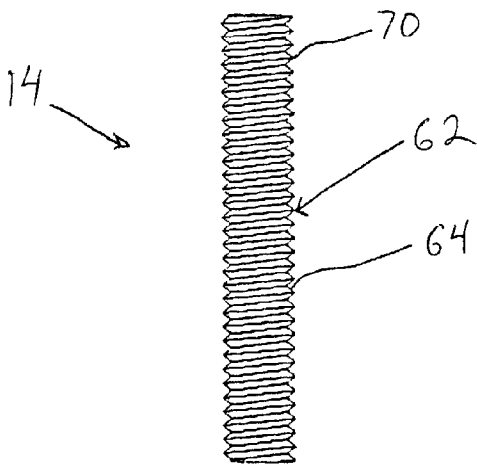

FIGURE 13C

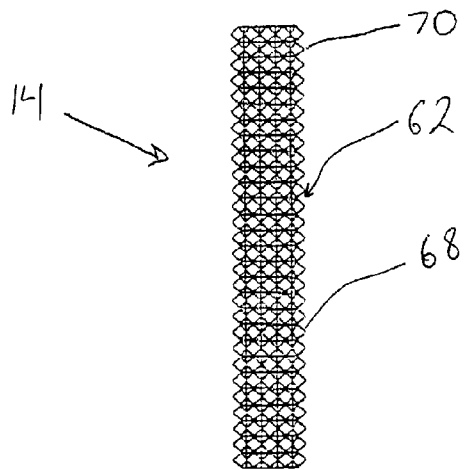

FIGURE 14A

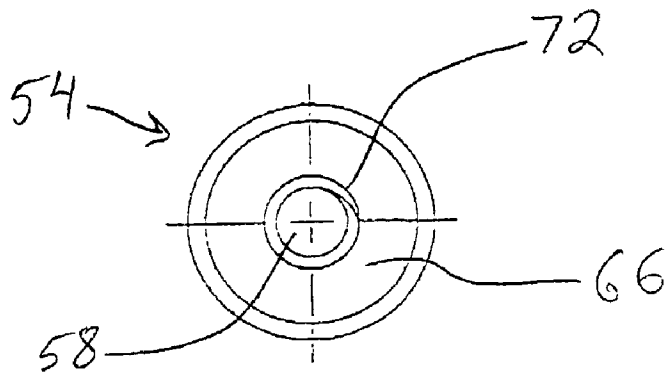

FIGURE 14B

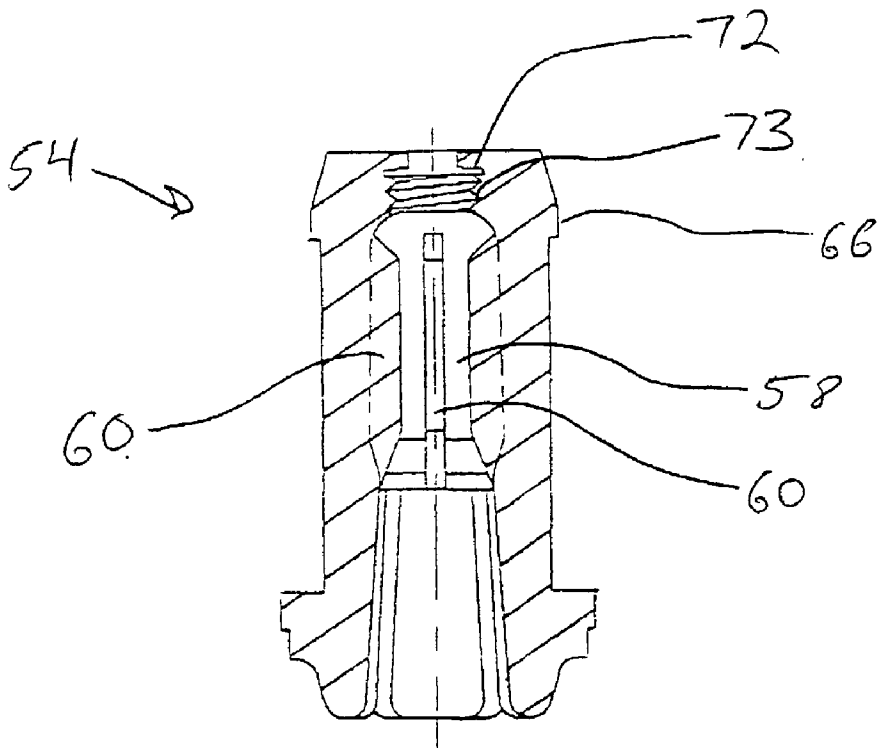

FIGURE 15A

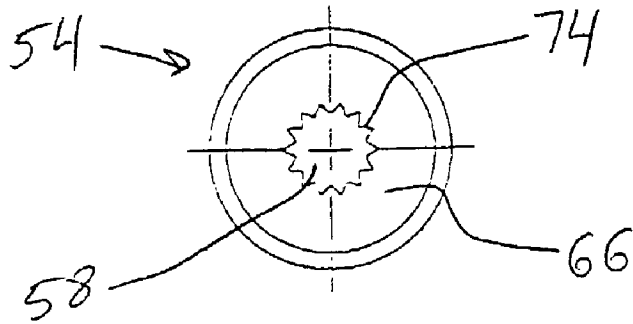

FIGURE 15B

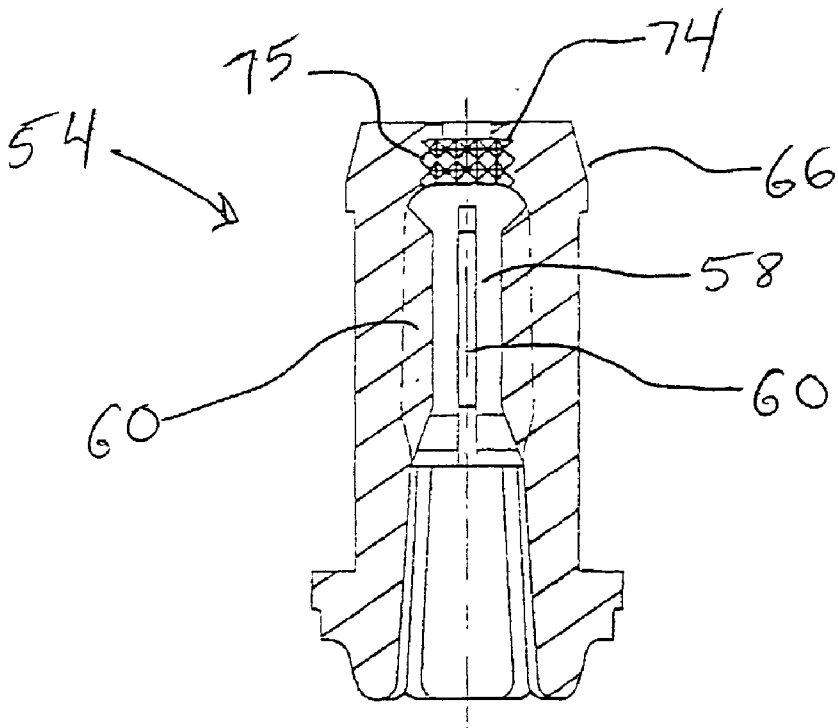

FIGURE 16A

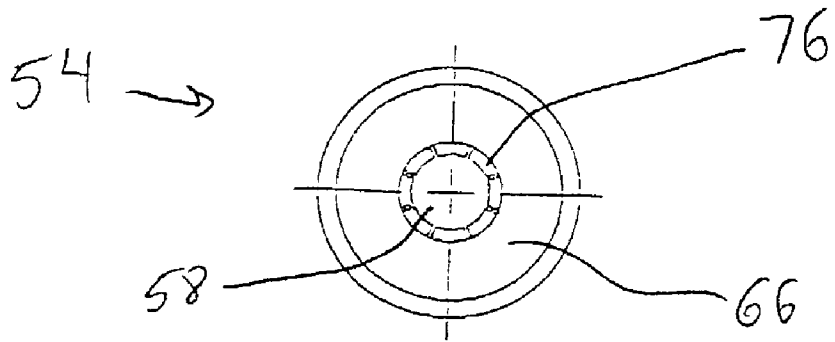

FIGURE 16B

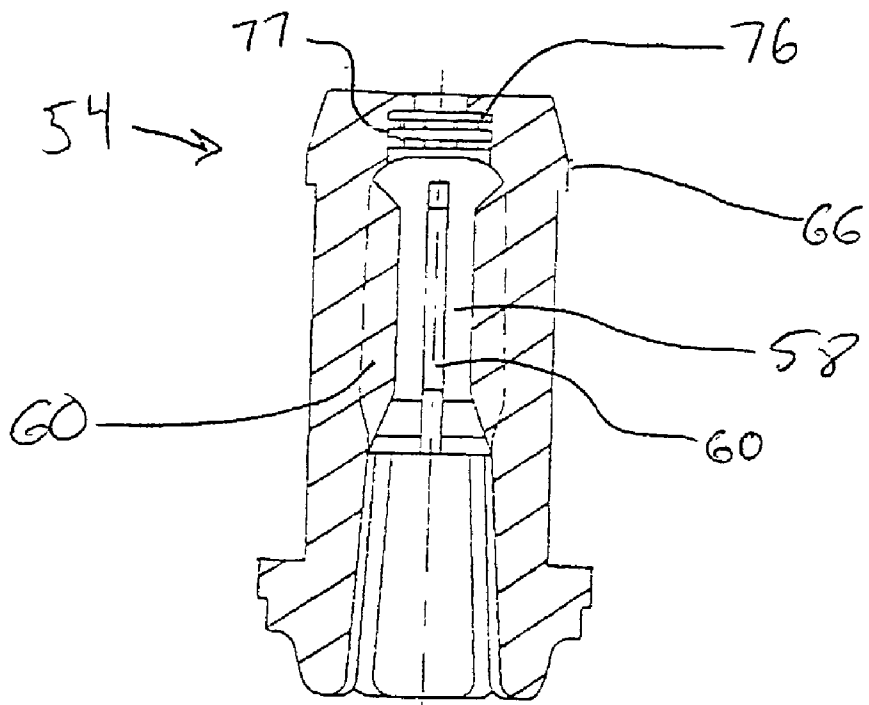

FIGURE 17A

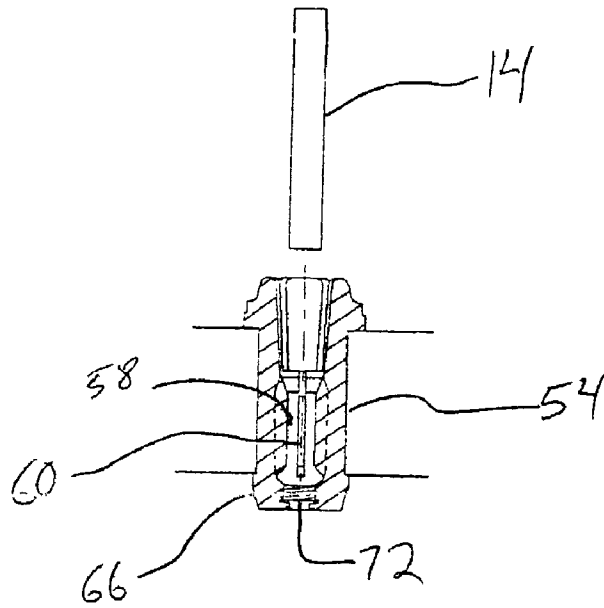

FIGURE 17B

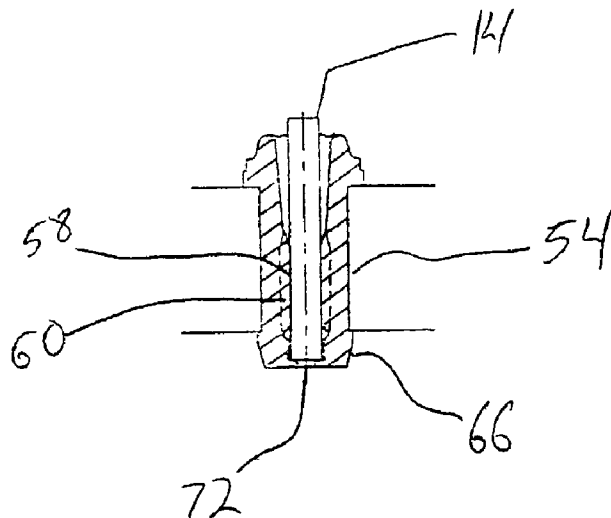

FIGURE 17C

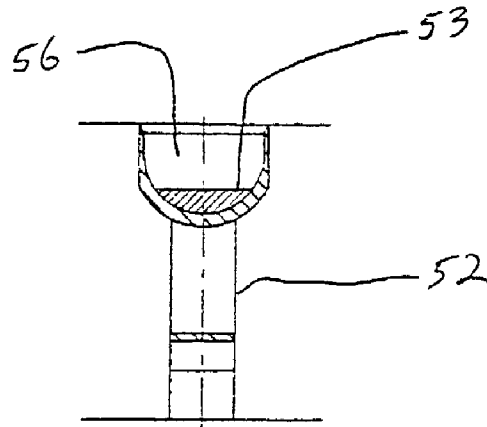

FIGURE 17D

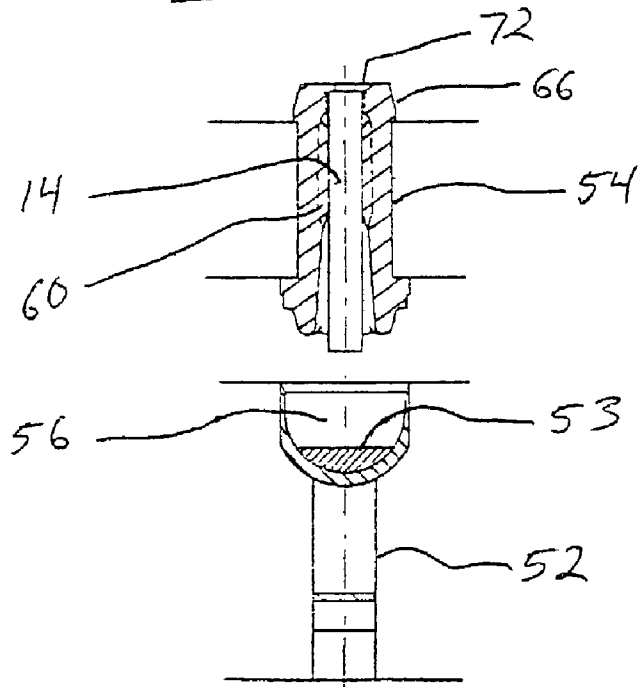

FIGURE 17E

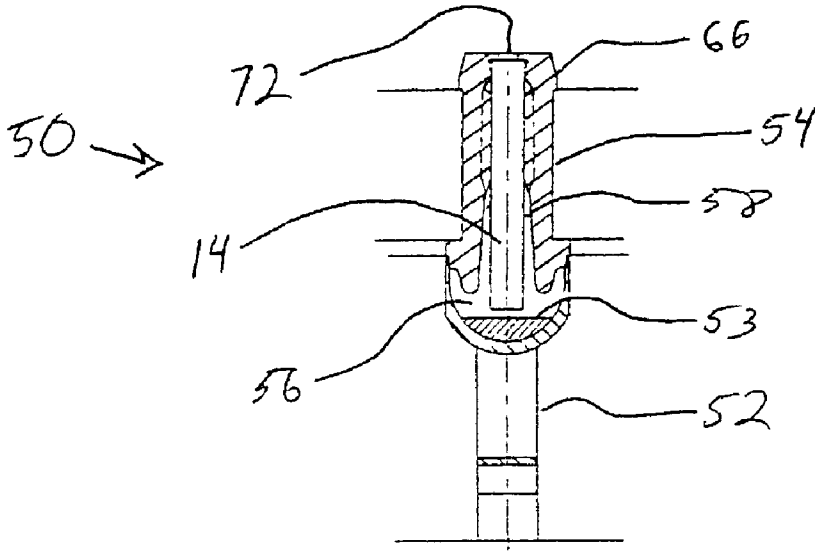

FIGURE 17F

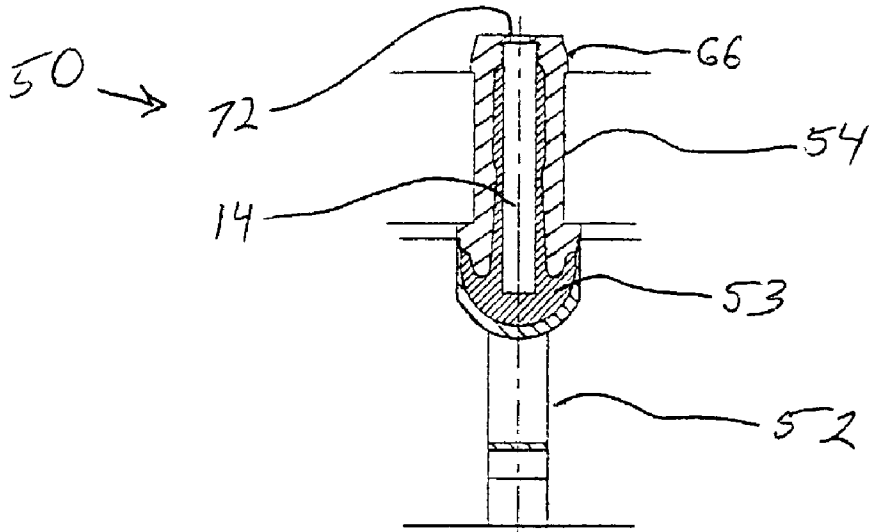

FIGURE 17 G

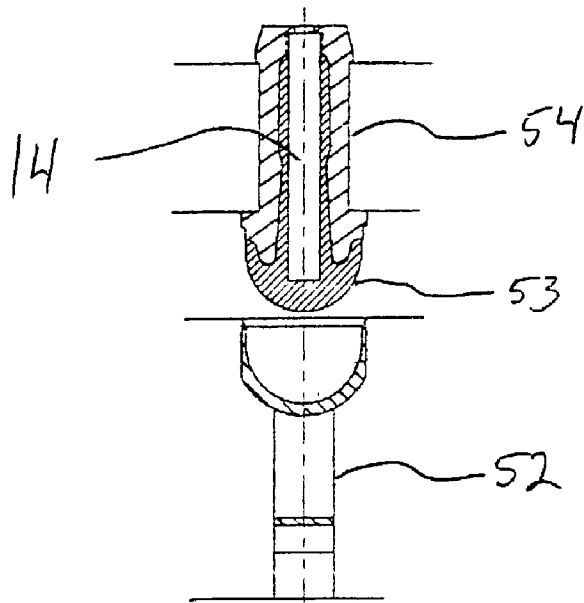
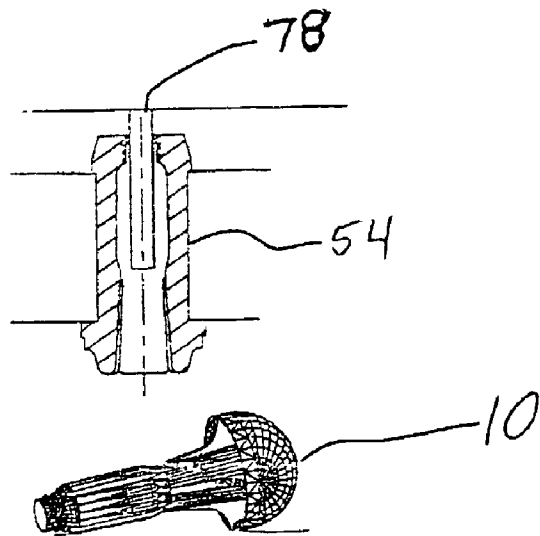

FIGURE 17 H



HEARING PROTECTIVE DEVICE AND METHOD OF MAKING SAME

CROSS REFERENCE TO RELATED APPLICATIONS

[0001] This application claims the benefit of provisional application serial No. 60/253,433, filed on Nov. 28, 2000, which is herein incorporated by reference in its entirety.

BACKGROUND

[0002] The present invention relates generally to hearing protective devices, and more particularly to hearing protective devices including a semi-rigid component.

[0003] The use of hearing protective and noise attenuating devices are well known, and various types of devices are available for this purpose. Such devices include, but are not limited to, earplugs and semi-aural devices. Foam components are well known for use with these devices, providing both sound attenuation and enhanced comfort for the wearer.

[0004] Earplugs are generally preferred for continuous use over longer periods of time. Foam earplugs composed of resilient polymer foam materials such as foam rubber or polyurethane are well known in the art. Slow recovery foam earplugs, such as those disclosed in U.S. Reissue. No. 29,487 to Gardner, Jr., are not only comfortable, but have also been shown to deliver high in-field noise protection at all frequencies. U.S. Pat. No. 5,203,352 to Gardner, Jr. also discloses a hearing protective earplug comprising a polymeric foam.

[0005] A hearing protective device may further include a cord that is attached to a pair of earplugs and extends therebetween. Conventional cords are commonly designed so that the cord may be permanently attached to the earplugs and more specifically, each end of the cord may be permanently attached to stem portions of the respective earplugs.

[0006] A typical semi-aural hearing protector assembly generally includes a resilient U-shaped band with holders at opposite ends, and a pair of inwardly directed ear protectors ("pods") that are detachably mounted to the holders. Semi-aural hearing protectors that enter the ear canal offer hearing protection but are somewhat less comfortable than those that simply cap the ear. U.S. Pat. No. 4,461,290 to Gardner, Jr. et al. discloses a semi-aural device incorporating a foam component. U.S. Pat. No. 4,671,265 to Anderson also discloses a semi-aural device.

[0007] With respect to these devices, the sound-attenuating (acoustical) component has been made both of flexible, rubber-like materials, and of foam. For earplugs and semi-aural devices, the rubber-like materials are advantageous because they allow the earplug or device to be directly inserted into the wearer's ear. However, such earplugs and devices typically become uncomfortable over long periods of use. Foam earplugs provide enhanced comfort, but may require rolling down before insertion.

[0008] A foam earplug with a stem can provide both the ease of insertion of rubber-like earplugs and the comfort of foam earplugs. A number of patents disclose earplugs having tips or flanges with a relatively stiff stem used to insert and remove the earplug. One earplug, shown in Prior Art FIG. 1, is described in U.S. Pat. No. 5,188,123 to Gardner, herein

incorporated by reference. This earplug includes a circular or ovoid resilient polymeric foam body having a rounded nose end. An elongated stem is axially embedded in the foam body and extends rearward and axially therefrom. The earplug may be used in a push-in or roll-down insertion mode.

[0009] While suitable for certain purposes, this prior art earplug requires an additional manufacturing step over conventional plugs to secure the stem in the foam body. Also, the material of the foam body is prone to peel from the insert. In addition, inclusion of a hard stem in the earplug could be a hazard for the user, the general concern being that potential injury could result should the hearing protector become impacted. On the other hand, if the stem is too soft, it tends to buckle upon insertion, limiting the fit of the earplug and reducing the potential usefulness of the stem.

[0010] Another attempted solution to the above-discussed deficiencies in the art is the use of a porous component as a stem as disclosed in U.S. Pat. No. 5,799,658 to Falco. Therein, individual porous stems are mechanically bonded to the foam during manufacture by controlled penetration of the foam by the porous component stem. However, the individual porous stems are relatively expensive and somewhat difficult to manufacture.

[0011] Accordingly, there remains a need for a stemmed foam earplug that is effective in providing hearing protection, yet convenient and comfortable to use, and has a more efficient and lower cost method of manufacture.

SUMMARY

[0012] The above discussed and other problems and deficiencies of the prior art are overcome or alleviated by the hearing protective device and method of manufacture of the invention.

[0013] In a preferred embodiment, an earplug comprises a foam and at least one component that is nestable with and bondable with the foam. The component is disposed at least partially within a foam insertable portion and at least partially within a foam handle portion.

[0014] In the preferred method of the present invention, the component is initially disposed in a mold. A foam or foamable mixture is introduced into the mold causing the foam to rise and surround the component. The component is nestable with and bondable with the foam. Also the component is at least partially within a foam insertable portion and at least partially within a foam handle portion.

[0015] In another preferred embodiment, a venting portion is provided in the mold. In still another preferred embodiment, a venting portion is provided on the component. The venting portions allow gas to escape the mold during rising of the foam. Further, the venting portions retain the foam within the mold during rising, thus preventing spillage of the foam outside the mold. Also, an amount of the foam is permitted to cure in the venting portion to effectively seal off the mold thus maintaining a pressure within in the mold desirable for curing of the foam therein.

[0016] The above discussed and other features and advantages of the present invention will be appreciated and understood by those skilled in the art from the following detailed description and drawings.

BRIEF DESCRIPTION OF THE DRAWINGS

[0017] Referring now to the drawings wherein like elements are numbered alike in the several FIGS.:

[0018] FIG. 1 is a conventional earplug;

[0019] FIG. 2 is an elevational view of an earplug, according to one embodiment of the invention;

[0020] FIG. 3 is a cross-sectional view of the earplug of FIG. 2;

[0021] FIG. 4 is an end view of the earplug of FIG. 2;

[0022] FIG. 5 is a cross-sectional view of the earplug of FIG. 2 in another embodiment;

[0023] FIG. 6 is a cross-sectional view of the earplug of FIG. 2 in another embodiment;

[0024] FIG. 7 is a cross-sectional view of the earplug of FIG. 2 in another embodiment;

[0025] FIG. 8 is a cross-sectional view of the earplug of FIG. 2 in another embodiment;

[0026] FIG. 9 is a perspective view of a set of corded earplugs;

[0027] FIG. 10 is a perspective view of foam components and a semi-rigid headband for a semi-aural device;

[0028] FIG. 11 is a cross-sectional view of one embodiment of a mold for forming the earplug of FIG. 2;

[0029] FIG. 12 is a top view of the mold of FIG. 11;

[0030] FIG. 13A is an elevational view of one embodiment of a component stem of the earplug of FIG. 2;

[0031] FIG. 13B is an elevational view of another embodiment of the component stem of FIG. 13A;

[0032] FIG. 13C is an elevational view of another embodiment of the component stem of FIG. 13A;

[0033] FIGS. 14A-14B are various views of another embodiment of a mold upper portion of FIG. 11;

[0034] FIGS. 15A-15B are various views of another embodiment of the mold upper portion of FIG. 11;

[0035] FIGS. 16A-16B are various views of another embodiment of the mold upper portion of FIG. 11; and

[0036] FIGS. 17A-17H show one embodiment of a method for manufacturing the earplug of FIG. 2.

DESCRIPTION OF THE PREFERRED EMBODIMENT

[0037] The device and method of manufacture of the invention comprises a foam and at least one component nestable with and bondable with the foam and a method of forming the same.

[0038] Referring now to FIGS. 2 and 3, in a preferred embodiment, a uniform foam earplug 10 comprises a foam insertable portion 12 and a foam handle portion 16. The foam substantially surrounds, encapsulates, or is nestable with and bondable with a component 14 having an embedded portion 18 with a tip 20. The embedded portion refers herein to that part of the component that is at least partially located within, and is bonded to, the foam insertable portion

12 and the foam handle portion 16. The foam handle portion 16 has a smaller diameter than the foam insertable portion 12. A depression 22, illustrated in FIG. 2 as a longitudinal groove, may extend within the foam handle portion 16 at least partially along the component 14. As is preferred, the earplug has a flange configuration 13. Alternate depressions (or a lack of depressions) and alternative earplug configurations are of course contemplated by the invention.

[0039] Referring now to FIG. 4, an end view of the exemplary earplug 10 is illustrated. The component 14 is disposed within the foam handle portion 16. As is illustrated by this embodiment, depressions 22 (four longitudinal grooves are shown) extend at least partially through the foam handle portion 16 and at least partially along a portion of the component 14.

[0040] Referring now to FIGS. 5-8, the preferred embodiments of the present invention are shown. Each figure illustrates a foam insertable portion 12, a flange 13, a component 14, a foam handle portion 16, an embedded portion 18, and a tip 20. FIG. 5 illustrates a bullet-shaped earplug. FIG. 6 illustrates a bell-shaped earplug. FIG. 7 illustrates a cone-shaped earplug. FIG. 8 illustrates a mushroom-shaped earplug.

[0041] The foam handle portions of two earplugs may be each attached to the end of a cord, an under-the-chin device, or a headband by bonding methods known in the art. Turning now to FIG. 9, a preferred embodiment includes respective earplugs 32, 34 that are each attached to respective ends 36, 38 of a cord of a device, shown generally at 30. FIG. 9 illustrates the foam insertable portion 12, the flange 13, the foam handle portion 16, and the longitudinal groove 22. The figure also illustrates the attachment of the cord ends 36, 38 to a passageway within the component 14 (e.g. a hollow component) of the earplugs.

[0042] Other means of cord attachment are contemplated, including attachment to at least one depression 22, to an exterior of the foam handle portion 16, and to an end of the component 14 (e.g., a solid component), among others.

[0043] The attachment of the earplugs 32, 34 to cord ends 36, 38 may occur by any known method in the art, but is preferably performed thermally, ultrasonically, or by crimping. Where the earplug and the cord materials are dissimilar, or where such materials do not form a strong bond under thermal or ultrasonic conditions, adhesives may additionally or alternatively be used.

[0044] Referring now to FIG. 10, a semi-aural device 40 is shown including earplugs 42, 44 attached to an under the chin device or headband component 45. The earplugs 42, 44 are each at least partially attached to respective ends 46, 48 of the headband 45. FIG. 10 illustrates the attachment of the earplugs 42, 44 to the headband ends 46, 48. The figure also illustrates the foam insertable portion 12, the flange 13, the component 14, the foam handle portion 16, and a longitudinal groove 22. The earplugs may attach to the headband by any method known in the art. The attachment method provides for the ability to remove the earplugs for replacement or cleaning.

[0045] Referring again to FIGS. 2-4, preferably, the component 14 is used as a stem of the earplug 10. As such, the component 14 should be rigid enough to aid insertion into the wearer's ear, yet soft and pliable enough to be comfort-

able and safe for the wearer. The semi-rigid component **14** should be selected of a material that is compatible with the foam of the insertable portion **12** and creates a bond between the component and the foam. Thus, the material is preferably a plastic material, but other embodiments may include paper, dense paper, rubber, foam, stiff foam, porous foam, relatively or semi-stiff foam, cardboard, or combinations thereof. The preferred component **14** can have disposed within at least one passage, such that the component **14** is hollow. Other passages (i.e. voids or relief cuts) are also contemplated for the component. The component **14** may also be of a solid or dense construction, and may include at least one passage. The component may also have disposed therein at least one indentation, dip or dimple.

[0046] Additionally, the component **14** may be of a different color than the foam of the earplug **10**, such that the color of the component **14** is visible through the one or more depressions **22** that may be formed in the handle portion **16**, thus clearly distinguishing the handle portion **16** of the earplug **10** for ease in inserting, removing, and otherwise identifying the earplug **10**. The depression **22** may be in the form of longitudinal grooves, relief cuts, letters or designs, or the like. An earplug **10** with a hollow component **14** may be manufactured such that components of a receiver, or other communication devices, may be attached to the earplug for communication purposes.

[0047] Suitable foams for use with the earplug **10** include those foams known in the art to be appropriate for use with foam earplugs or other foam components for hearing protective devices. For example, such foams may include soft, pliable self-rising foams with instant recovery. Suitable foams may also include polyurethane or acrylic blend foams with slow recovery. Other foams include PVC, silicone, and nitrile, among others. A suitable foam is described in U.S. Pat. No. 5,792,998 to Gardner, Jr. et al., herein incorporated by reference. The earplug described therein is comprised of a dynamically stiff foam material having a low static stiffness, and a high dynamic stiffness. Another suitable foam is described in U.S. Pat. No. 4,158,087 to Wood, herein incorporated by reference.

[0048] In a method of manufacturing the earplug **10** of FIGS. 1-8, the component **14** is disposed, suspended, or placed into a cavity of an earplug mold. A foam or a foamable mixture is introduced into the mold, and caused to rise. Rising may be accomplished by any suitable means, for example by using a self-rising foam. As the foam rises, it at least partially surrounds, encapsulates, or is nestable with and bondable with, or bonds to, the component. Molding may be performed with any suitable molding process and device such as is known in the art.

[0049] An earplug mold **50**, as shown in FIG. 11, includes a mold lower portion **52** and a mold upper portion **54**.

[0050] The mold lower portion **52** is made of a rigid, non-porous material, for example, a polymeric material such as polypropylene or high-density polyethylene. Also, the mold lower portion **52** may be made of a metal such as aluminum. The mold lower portion **52** includes a lower cavity **56** for receiving and shaping a foam or foamable mixture **53** to form the foam insertable portion **12** of the earplug **10**.

[0051] The mold upper portion **54** of the earplug mold **50** is made of a flexible material, for example, thermoplastic

rubber, thermoset rubber, etc., and includes an upper cavity **58** for receiving and retaining the component **14** during manufacture of the earplug **10** and for receiving and shaping the rising foam **53**, as discussed herein. In one embodiment, the component **14** is retained in the mold upper portion **54** by ribs **60** disposed in the cavity **58**. In one embodiment, the ribs **60** include four flanges which project inwardly into the cavity **58** and traverse the cavity **58** in a longitudinal direction thereof.

[0052] To manufacture the earplug **10**, the foam **53** is disposed in the mold lower cavity **56**. The component **14**, particularly shown in FIG. 13A, is inserted in the upper portion **54** such that the component **14** contacts the ribs **60** and is thus retained within the cavity **58**. The mold upper portion **54** is positioned proximate the mold lower portion. The cavity **56** communicably engages the cavity **58**. The foam **53** is allowed to rise from the cavity **56** into the cavity **58** and to encapsulate the component **14**. A bond is formed between the foam **53** and the encapsulated component **14**. The foam is shaped by the lower and upper mold portions **52, 54**, the foam **53** is allowed to cure, and then the foam **53** and component **14** are ejected from the mold **50** as the earplug **10**.

[0053] In another embodiment, the component **14** includes component venting means **62**, as shown in FIGS. 13B and 13C, to allow for a gas to escape from the mold cavities **56, 58** during manufacture of the earplug **10**. Specifically, the component venting means **62** allows for gas to escape the cavities during the foaming process, that is, during rising and rising of the foam within the mold **50**. The vented gas includes air originally present within the mold prior to the foaming process and any gas that may be evolved during the process.

[0054] The component venting means **62**, in one embodiment, includes screw threads **64** disposed helically about the component **14**. The screw threads **64** contact the mold upper portion **54** in the upper cavity **58** at least at a top end **66** of the mold upper portion **54**. The contact of the screw threads **64** with the mold upper portion **54** forms vent passages there between which allow passage of gas during the foaming process. That is, vent passages are delimited by the screw threads **64** and a surface of the top end **66** of the upper mold portion **54** forming the upper mold cavity **58**. The component **14** having screw threads **64** extends from the upper cavity **58** such that the vent passages traverse from the upper cavity **58** to an exterior of the of the mold upper portion **54**. Thus, the vent passages allow gas to travel from the cavities **56, 58** to the exterior of the mold **50** during the foaming process. More specifically, as the foaming process commences, the foam begins to rise and occupy an increased volume of the mold cavities **56, 58**, thus increasing the pressure within the cavities **56, 58**. Due to this increased pressure, air residing within the mold cavities **56, 58** prior to commencement of the foaming process is forced out of the mold cavities **56, 58** through the vent passageways to an exterior of the mold **50**.

[0055] The component venting means **62**, in another embodiment, includes knurls **68**, as shown in FIG. 13C. The knurls **68** are protrusions formed along the length of the component **14** which extend radially therefrom. When the component **14** having knurls **68** is inserted in the mold upper portion **54**, the knurls **68** contact the mold upper portion **54**

to form vent passageways therebetween. That is, the vent passageways are delimited by the knurls **68** and the surface of the top end **66** of the upper mold portion **54** forming the upper mold cavity **58**. The vent passageways permit gas to travel from the cavities **56, 68** to the exterior of the mold **50** during the foaming process similarly as discussed above with reference to the screw threads **64**.

[**0056**] The screw threads **64** and the knurls **68**, in one embodiment, are formed along the length of the component **14**. In another embodiment, the screw threads **64** and the knurls **68** are formed only at a top end **70** of the component **14**. In still another embodiment, the screw threads **64** and knurls **68** are formed only at a confined portion located somewhere between respective ends of the component **14**, for example, at a midpoint between the respective ends. The top end **70** of the component **14** contacts the top end **66** of the mold upper portion **54** when the component **14** is inserted in the mold upper portion **54** during the manufacture of the earplug **10**.

[**0057**] Size and spacing of the screw threads **64** and the knurls **68** are predetermined to allow a certain volume of gas to pass through the vent passageways when a certain pressure accumulates in the cavities **56, 58** during the foaming process. Further, the screw threads **64** and the knurls **68** are designed to prevent passage of the rising foam **53** from the cavities **56, 58** to the exterior of the mold thus preserving the integrity of the mold **50** and reducing waste during the molding process.

[**0058**] Additionally, the screw threads **64** and the knurls **68** allow a certain volume of the rising foam **53** to enter the vent passageways and cure therein effectively sealing off the mold cavities **56, 58** from the exterior of the mold **50**. That is, after the excess air within the mold cavities **56, 58** is vented, the rising foam **53** is permitted to fill the vent passageways and to cure therein. More specifically, the rising foam is directed through the vent passageways which act in this instance essentially as a tortuous path to shear a portion of the foam causing the foam to collapse and/or densify and cure therein to seal off the vent passageways. This sealing effect serves to maintain a pressure within the mold cavities **56, 58** optimal for curing of the foam and, hence, for formation of the earplug **10**.

[**0059**] As a result of the densification of the foam at the vent passageways, the resulting earplug **10**, as shown in FIGS. **2-4**, includes foam formed at the screw threads **62** or the knurls **64**. That is, foam which cures in the vent passageways to form the effective seal of the mold **50** is removed from the mold **50** as a portion of the earplug **10**. The foam at the screw threads **62** or knurls **64** has a greater hardness and a higher density than foam formed at the insertable and handle portions **12** and **16**, respectively.

[**0060**] In another embodiment, shown in FIGS. **14A** and **14B**, the mold upper portion **54** includes a screw vent portion **72** formed at the top end **66**. The screw vent portion **72** includes screw threads **73** formed helically on the mold upper portion **54** along a longitudinal axis of the upper cavity **58**.

[**0061**] During manufacture of the earplug **10**, the component **14** of FIG. **13A** is inserted in the upper mold portion **54** of FIG. **14B** and retained therein by the ribs **60**. The component **14** contacts the screw threads **73** of the screw

vent portion **72** to form helical vent passages extending from the upper cavity **58** to the exterior of the mold upper portion **54**. During the foaming process, gas, particularly air originally disposed within the cavities, travels from the upper cavity **58** through the vent passages to the exterior of the mold upper portion **54**, similar to that described above with reference to the screw threads **64** formed on the component **14** shown in FIG. **13B**.

[**0062**] In another embodiment, shown in FIGS. **15A** and **15B**, the mold upper portion **54** includes a knurled vent portion **74** formed at the top end **66**. The knurled vent portion **74** includes knurls **75** protruding into the mold upper cavity **58**. During manufacture of the earplug **10** using this embodiment of the mold upper portion **54**, the component **14** of FIG. **13A** is inserted in the cavity **58** and retained therein by the ribs **60** such the component **14** contacts the knurls thus forming vent passageways therebetween. During the foaming process, gas, particularly air originally disposed within the cavities, travels from the upper cavity **58** through the vent passages to the exterior of the mold upper portion, similar to that described above with reference to the knurls **68** formed on the component **14** shown in FIG. **13C**.

[**0063**] In another embodiment, shown in FIGS. **16A** and **16B**, the mold upper portion **54** includes a flange vent portion **76** formed at the top end **66**. The flange vent portion **76** includes annular flanges **77** formed on the mold upper portion **54** about a longitudinal axis thereof and projecting into the upper cavity **58**. The flanges **77** include at least one space formed respectively therein. More preferably, the flanges include a plurality of spaces formed periodically across the annular distance of the flanges.

[**0064**] During manufacture of the earplug **10** using the mold upper portion **54** having the flange vent portion **76**, the component **14** of FIG. **13A** is inserted in the cavity **58** and retained therein by the ribs **60** such the component **14** contacts the flanges. Vent passageways are formed between the component **14** and the mold upper portion **54** by communication of the spaces in the flanges **77**. Accordingly, during the foaming process, gas, particularly air originally disposed within the cavities, is permitted to travel from the upper cavity **58** through the vent passages formed by the communication of the annular tabs **77** and the upper mold portion **54** to the exterior of the mold upper portion, thus allowing optimal production of the earplug **10**.

[**0065**] The upper mold portion **54** including at least one of the screw vent portion **72**, knurl vent portion **74**, and flange vent portion **76**, as mentioned, allows gas to travel from the mold cavities **56, 58** to the exterior of the mold **50**. Specifically, during the foaming process, the foam **53** rises within the cavities **56, 58** thus increasing the pressure therein. This increased pressure forces air originally present within the cavities **56, 58** to travel through the vent passages to the exterior of the mold **50**. This venting allows proper rising and formation of the foam **53**.

[**0066**] Additionally, the upper mold portion **54** including at least one of the screw vent portion **72**, knurl vent portion **74**, and flange vent portion **76**, prevents overflow of the rising foam material **53** to the exterior of the mold **50** thus preserving the integrity of the mold **50** and reducing waste associated with the molding process.

[**0067**] Further, the upper mold portion **54** including at least one of the screw vent portion **72**, knurl vent portion **74**,

and flange vent portion 76, allows a certain volume of the rising foam 53 to enter the vent passageways and cure therein effectively sealing off the mold cavities 56, 58 from the exterior of the mold 50. That is, after the excess air within the mold cavities 56, 58 is vented, the rising foam 53 is permitted to fill the vent passageways and to cure therein. This sealing effect serves to maintain a pressure within the mold cavities 56, 58 which is optimal for curing of the foam and, hence, for formation of the earplug 10.

[0068] FIGS. 17A-17H show a method of manufacturing the earplug 10 using the mold upper portion 54 including the screw vent portion 72.

[0069] In FIGS. 17A and 17B, the component 14 is inserted into the cavity 58 of the mold upper portion 54 and retained therein by ribs 60. The foam 53 is disposed in the cavity 56 of the mold lower portion 52, as shown in FIG. 17C. The mold upper portion 54 with the component 14 inserted and retained therein is brought in proximity of the mold lower portion 52, as shown in FIG. 17D.

[0070] In FIGS. 17E and 17F, the cavities 56 and 58 are brought into communication, the component extending from the cavity 58 into the cavity 56. The foam 53 is then allowed and/or caused to rise throughout the cavities 56 and 58. In this way, a portion of the component 14 exposed to the cavities 56 and 58 is completely encapsulated by the foam 53. The foam 53 is then cured into a shape determined by the shape of the cavities 56, 58. During this process, the foam 53 forms a strong bond directly with the component 14.

[0071] During the foam rising process, gas within the mold cavities 56, 58 is permitted to pass through the vent passageways formed between the screw vent portion 72 and the component 14 when the gas attains a certain pressure within the cavities 56, 58. This gas, as mentioned, is air originally disposed within the cavities 56, 58 and/or any gas that may be evolved or otherwise present during the foaming process.

[0072] The screw threads 73 of the screw vent portion 72 prohibit the rising foam material from spilling to the exterior of the mold 50. However, a certain amount of the rising foam material 53 is permitted to enter the vent passageways and to cure therein, sealing off the cavities 56, 58 from the exterior of the mold 50, and thus maintaining a desired pressure therein for curing of the foam and formation of the earplug 10.

[0073] Once the foam 53 has cured, the mold upper portion 54 is removed from engagement with the mold lower portion 52, as shown in FIG. 17G. The component 14 remains retained in the mold upper portion by the ribs 60. The foam 53, now bonded with the component 14, leaves the cavity 56 of the mold lower portion 52.

[0074] Then, as shown in FIG. 17H, a tool 78 is used to eject the component 14 with bonded foam 53 from the mold upper portion 54, thus completing the manufacturing of the earplug 10. Contact of the ribs 60 with the component 14 during manufacturing of the earplug 10 results in the formation of the depressions 22 which may be shaped as desired by shaping or contouring the ribs 60 accordingly.

[0075] The earplug 10 is also similarly manufactured utilizing the mold upper portion 54 having the knurled vent portion 74 and utilizing the mold upper portion 54 having the flange vent portion 76.

[0076] In another embodiment, continuous manufacture of a plurality of the earplugs 10 is provided by moving the mold lower portions 52 under a continuous pour machine which deposits a charge of the foam 53 in the cavities 53 and then engaging the mold upper portions with the mold lower portions to allow curing of the foam 53.

[0077] The invention, of which exemplary preferred embodiments are disclosed herein, provides a stemmed foam earplug that is effective in providing hearing protection, yet convenient and comfortable to use, and has a more efficient and lower cost method of manufacture. The earplug includes a foam insertion portion encapsulating and bonded directly to a component stem; the foam insertion portion providing a comfortable portion for an insertion into a wearer's ear; the component stem providing the necessary rigidity to facilitate proper insertion of the insertion portion into the ear and/or providing a means for connecting a cord, under the chin device, or headband component.

[0078] The method provided herein is particularly advantageous in that an effective earplug is produced easily, efficiently, at low cost, and without the necessity of an additional bonding step. Furthermore, the bond formed according to the present invention is strong and durable, resulting in a dependable earplug having a long use life.

[0079] The costs for manufacture of the invention are lower than for conventional earplugs because the disposing of the foam around the component eliminates the need for a separate bonding step, which was otherwise required to adhere the component to the foam and, further, because costly porous component stems are not required due to the disclosed venting means.

[0080] The venting means provided allows gas to escape from the cavities of the respective mold portions during the foaming process. The design of the venting means ensures that a desirable volume of gas escapes while preventing overflow of the foam from the cavities to the exterior of the mold. Further, the venting means allows a certain volume of the rising foam material to enter the vent passageways and to cure therein effectively sealing off the mold cavities from the exterior of the mold thus maintaining a desired pressure in the cavities optimal for curing the foam material and hence for forming the earplug.

[0081] The venting means allows utilization of simple, low cost component stems while ensuring consistent and optimal rising, curing, and bonding of the foam to form the earplug.

[0082] In these ways, the invention is effective for providing low cost, reliable hearing protection to a wearer which is convenient and comfortable to use.

[0083] While preferred embodiments have been shown and described, various modifications and substitutions may be made thereto without departing from the spirit and scope of the invention. Accordingly, it is to be understood that the present invention has been described by way of illustrations and not limitation.

1. An earplug comprising:

a foam; and

a component nestable with and bondable with said foam, wherein said component is disposed at least partially

- within a foam insertable portion and at least partially within a foam handle portion.
2. The earplug of claim 1, wherein said foam is selected from the group comprising polyurethane, acrylic, acrylic blends, and mixtures and combinations including at least one of the foregoing materials.
 3. The earplug of claim 1, wherein said component is selected from the group comprising plastic, paper, dense paper, stiff foam, semi-stiff foam, foam, porous foam, cardboard, rubber, and combinations including at least one of the foregoing materials.
 4. The earplug of claim 1, further comprising at least one depression formed in said foam at least partially along said component and at least partially along said foam handle portion.
 5. The earplug of claim 1, wherein said at least one component has at least one passage disposed therein.
 6. The earplug of claim 1, wherein said component comprises a vent for venting a mold during a manufacturing of the earplug.
 7. The earplug of claim 6, wherein said vent comprises a screw threaded portion.
 8. The earplug of claim 6, wherein said vent comprises a knurled portion.
 9. The earplug of claim 6, wherein said vent is disposed across the length of the component
 10. The earplug of claim 6 wherein said vent is disposed at a top of said component.
 11. A set of a first earplug and a second earplug comprising:
 - a foam of said first earplug;
 - a foam of said second earplug;
 - a first component nestable with and bondable with said foam of said first earplug, wherein said first component is disposed at least partially within a first foam insertable portion and at least partially within a first foam handle portion;
 - a second component nestable with and bondable with said foam of said second earplug, wherein said second component is disposed at least partially within a first foam insertable portion and at least partially within a first foam handle portion; and
 - a connection device having a first end and a second end, the first end being attached to said first foam handle portion, and the second end being attached to said second foam handle portion.
 12. The set of two earplugs of claim 11, wherein said foam of said first earplug and said foam of said second earplug is selected from the group comprising polyurethane, acrylic, acrylic blends, and mixtures and combinations including at least one of the foregoing materials.
 13. The set of two earplugs of claim 11, wherein said first component and said second component is selected from the group comprising plastic, paper, dense paper, foam, porous foam, stiff foam, semi-stiff foam, cardboard, rubber, and combinations including at least one of the foregoing materials.
 14. The set of two earplugs of claim 11, further comprising a depression formed in said foam of said first earplug at least partially along said first component and at least partially along said foam handle portion of said first earplug and in said foam of said second earplug at least partially along said second component and at least partially along said foam handle portion of said second earplug.
 15. The set of two earplugs of claim 11, wherein said first component is nonporous and said second component is nonporous.
 16. The set of two earplugs of claim 11, wherein said connection device is a flexible cord.
 17. The set of two earplugs of claim 11, wherein said connection device is an under the chin device or a headband.
 18. A method of making an earplug comprising:
 - disposing a component within a mold;
 - introducing a foam or foamable mixture into said mold; and
 - causing said foam or said foamable mixture to rise about said component such that said component is nested within and bonded with said foam, such that said component is at least partially within a foam insertable portion and at least partially within a foam handle portion.
 19. The method of claim 18, wherein said foam or said foamable mixture is self-rising.
 20. The method of claim 18, wherein said foam is selected from the group comprising polyurethane, acrylic, acrylic blends, and mixtures and combinations including at least one of the foregoing materials, and wherein said component is selected from the group comprising plastic, paper, dense paper, foam, porous foam, stiff foam, semi-stiff foam, cardboard, rubber, and combinations including at least one of the foregoing materials.
 21. The method of claim 18, further comprising forming a depression in said foam along said component.
 22. The method of claim 18, further comprising forming a passage in said component.
 23. The method of claim 18, further comprising venting the mold during said causing said foam or foamable mixture to rise to allow a gas to move from an interior of the mold to an exterior of the mold.
 24. The method of claim 23 wherein said venting includes forming venting passageways between the component and the mold during said disposing of the component within the mold.
 25. The method of claim 24, wherein said venting passageways extend from the interior to the exterior.
 26. The method of claim 23, further comprising sealing said interior of said mold from said exterior after said venting.
 27. The method of claim 26, wherein said sealing comprises allowing a volume of said rising foam or foamable mixture to enter a vent used in said venting and curing said volume therein.
 28. A mold for forming a foam earplug comprising:
 - a lower mold portion including a lower cavity; and
 - an upper mold portion including an upper cavity and a means for venting a gas during a rising of the foam;
 wherein the lower and upper mold portions are engageable so as to communicably engage the lower and upper cavities.

29. The mold of claim 28 wherein said means for venting comprises a screw thread helically disposed on the upper mold portion in the upper cavity.

30. The mold of claim 28 wherein said means for venting comprises a plurality of knurls disposed on the upper mold portion in the upper cavity.

31. The mold of claim 27 wherein said means for venting comprises at least one annular flange disposed on the upper

mold portion in the upper cavity, the flange including at least one space formed therein to allow said venting of said gas.

32. The mold of claim 27 further comprising a plurality of ribs projecting from the upper mold portion radially into the upper cavity and traversing the upper cavity in a longitudinal direction.

* * * * *