

No. 865,257.

PATENTED SEPT. 3, 1907.

H. KOHL.

APPARATUS FOR NARROWING THE WALLS OF HOLLOW BODIES.

APPLICATION FILED APR. 15, 1903.

4 SHEETS—SHEET 1.

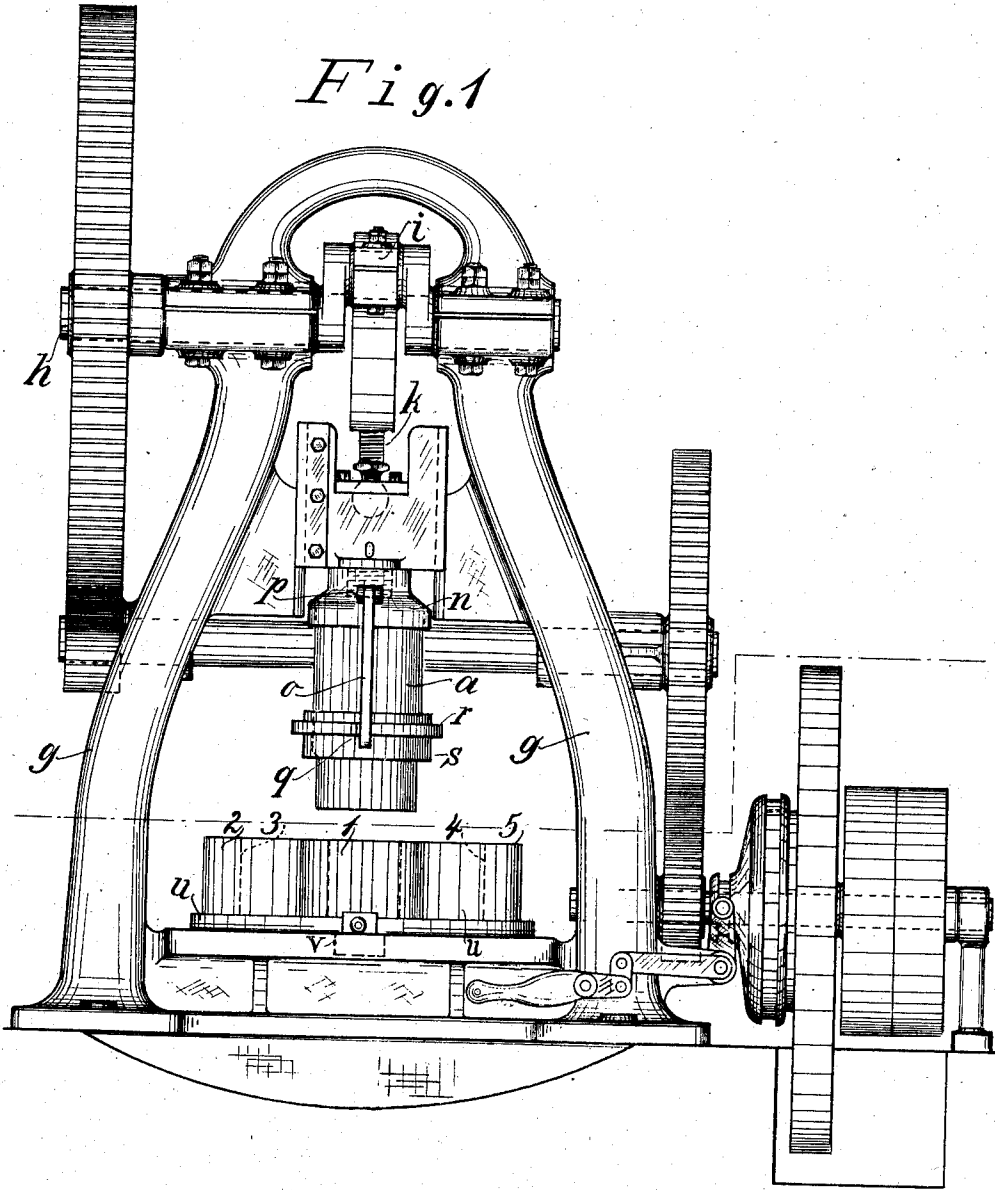

Witnesses:
Sean Hofer
Josef Fokerrath

Inventor:
Hermann Kohl
per *Theodor Heese*
Attorney.

H. KOHL.

APPARATUS FOR NARROWING THE WALLS OF HOLLOW BODIES.

APPLICATION FILED APR. 15, 1903.

Fig. 4

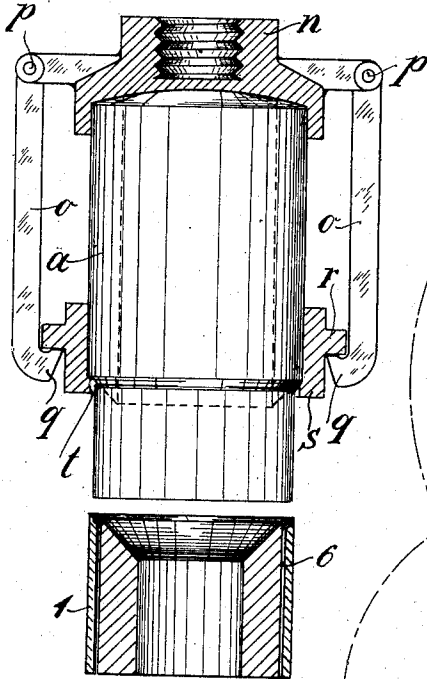
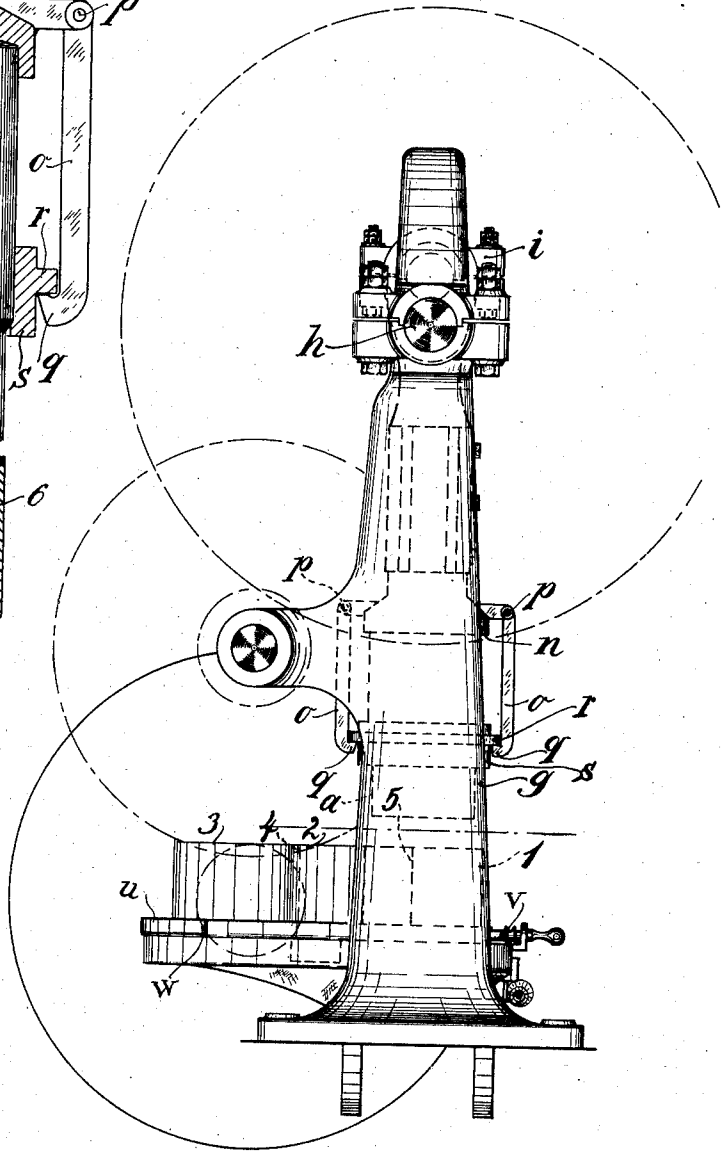

Fig. 2



Witnesses:
Sean Hofer
Josef Jokenroth

Inventor:
Alexmann Stoll
 per
Theodor Heese
 Attorney.

No. 865,257.

PATENTED SEPT. 3, 1907.

H. KOHL.

APPARATUS FOR NARROWING THE WALLS OF HOLLOW BODIES.

APPLICATION FILED APR. 15, 1903.

4 SHEETS—SHEET 3.

Fig. 5

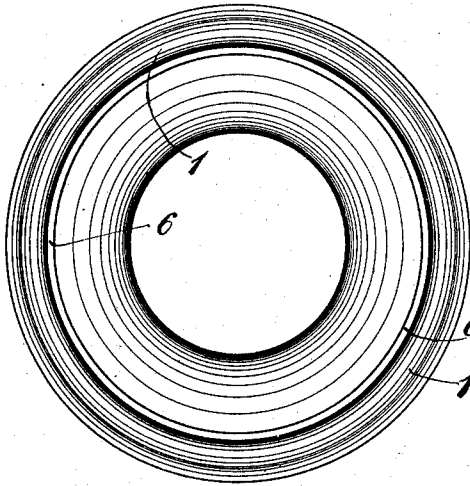

Fig. 6

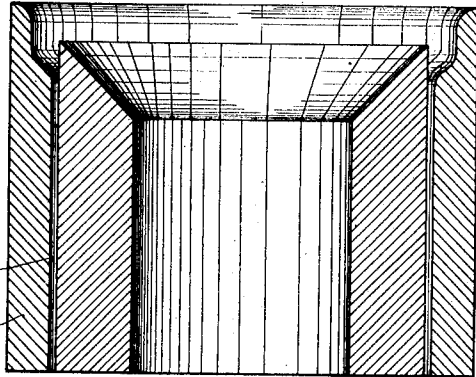
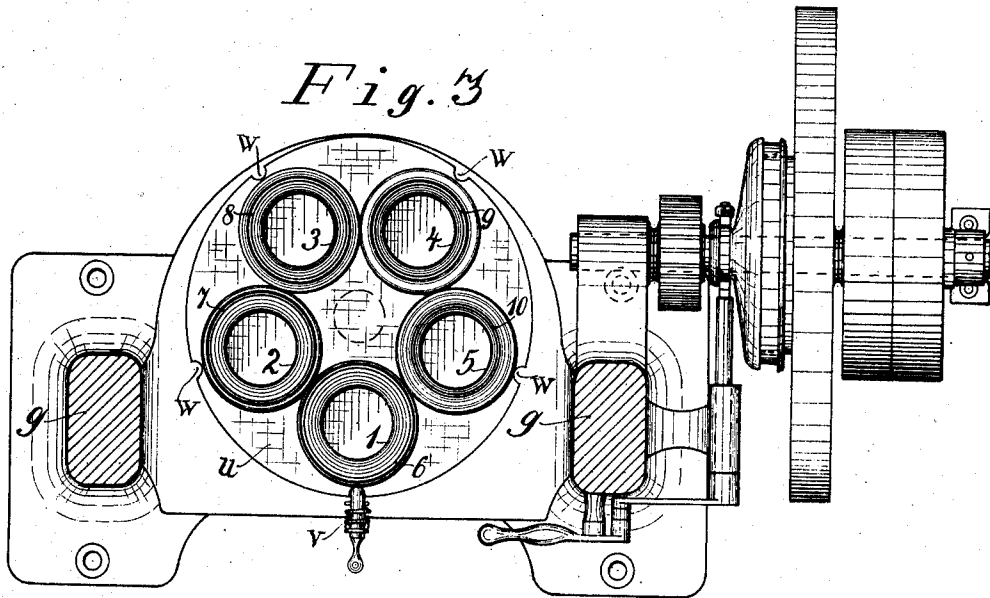

Fig. 7



Witnesses:

Sean Hofer

For of Schenck

Inventor:

Hermann Kohl

per Theodor Heese
Attorney.

No. 865,257.

H. KOHL.

PATENTED SEPT. 3, 1907.

APPARATUS FOR NARROWING THE WALLS OF HOLLOW BODIES.

APPLICATION FILED APR. 15, 1903.

4 SHEETS—SHEET 4.

Fig. 7

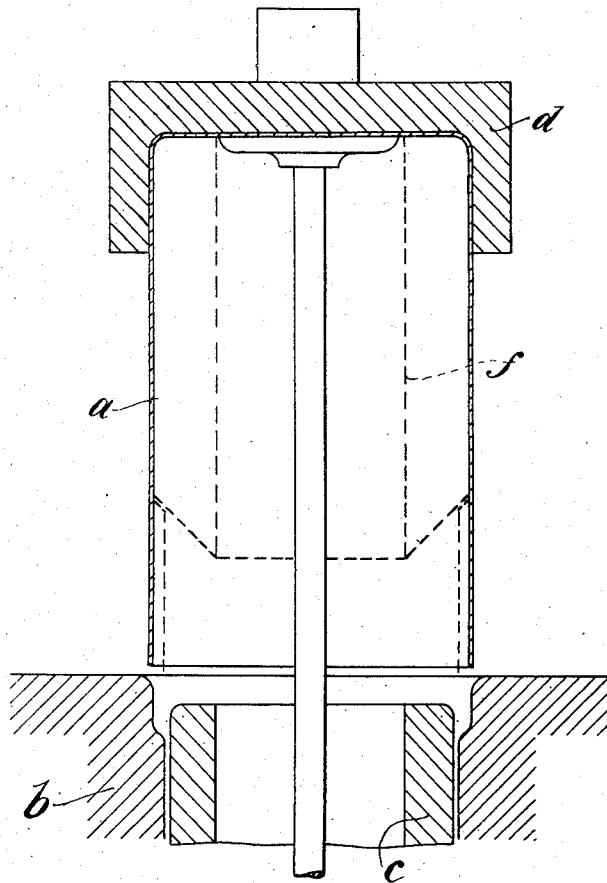

Witnesses:
Sean Hofer
Josef Finkenroth

Inventor:
Hermann Kohl
per Theodor Heese
Attorney.

UNITED STATES PATENT OFFICE.

HERMANN KOHL, OF RODENKIRCHEN, NEAR COLOGNE, GERMANY.

APPARATUS FOR NARROWING THE WALLS OF HOLLOW BODIES.

No. 865,257.

Specification of Letters Patent.

Patented Sept. 3, 1907.

Application filed April 15, 1903. Serial No. 152,799.

To all whom it may concern:

Be it known that I, HERMANN KOHL, a subject of the King of Prussia, German Emperor, residing at Rodenkirchen, near Cologne-on-the-Rhine, in the Province of the Rhine, Kingdom of Prussia, German Empire, have invented a new and useful Apparatus for Narrowing the Walls of Hollow Bodies, of which the following is a specification.

The present invention relates to improvements in an apparatus for narrowing the walls of hollow bodies and more especially of such hollow bodies as have thin walls and which are closed at one end, while the open end is to be narrowed.

Hitherto, the production of such hollow bodies with narrowed open ends has been very tiresome and expensive, furthermore as manufactured hereto the walls are often defective and many useless bodies are obtained. The reason of these drawbacks in manufacture is that rollers have been used for widening and narrowing the bodies which causes the material to become hard and brittle.

According to my invention, a die-press is used for narrowing the open ends of the hollow bodies closed at one end. For this purpose, cylindrical hollow bodies are used, the diameter of which corresponds to the largest diameter of the finished bodies. The edge surrounding the opening of the said body is inserted between an inner and an outer die suitable for narrowing and then the part to be narrowed is forced by pressure to pass the angular space between the said dies. In the use of my apparatus, no edge is lost, but the original edge of the not narrowed body forms the edge of the finished body without any loss.

If, as usually the case, the intended narrowing is so considerable that it cannot be produced in one stroke of the die-press the same has to be made gradually, by inserting another narrower pair of dies on every stroke. In this case, I prefer to arrange the necessary pairs of dies on a movable support so that they can be moved under the hollow body one after another, whereby I dispense with the tiresome exchange of dies.

In order to make my invention more clear reference is made to the accompanying drawings in which

Figure 1 is a rear view of a die-press for carrying out my new process, Fig. 2 is a side-view of the press, Fig. 3 is a horizontal section of Fig. 1, Fig. 4 shows the device for attaching the hollow body to the press on a larger scale and by a view rectangular to that of Fig. 1; the corresponding pair of dies being indicated in section, partly broken away, Fig. 5 is, on a still larger scale, a plan-view of one pair of dies, Fig. 6 shows a vertical section of the same, Fig. 7 is a diagram for explaining the principle of the machine.

The invention will be more readily understood by first describing the diagram of Fig. 7. *a* is the hollow body of cylindrical shape, closed at the top and open at

the bottom; *b* is the outer die, *c* is the inner die, *d* is a disk adapted to move up and down thus causing the same movement of the hollow body *a* which is attached to the said disk by means not shown in Fig. 1. When the disk *d* moves downward, the edge surrounding the open end of the hollow body *a* enters the angular space between the inner die *c* and the outer die *b*, which angular space has a diameter smaller than that of the hollow body. On continued downward motion of the disk *d*, that lower part of the body *a* which is intended to be narrowed, is entirely forced by pressure into the said space left by the dies so that the body *a* assumes the form shown in dotted lines. The disk *d* will then be raised. If the narrowing of the hollow body is to be continued by means of a narrower pair of dies, a mandrel is to be provided within the interior of the hollow body to take off the counter-pressure of the die. This mandrel *f* is indicated by dotted lines. Since at the end of the narrowing operation the mandrel must be withdrawn from the hollow body through the narrowed opening of the same it must be arranged in any well-known manner for allowing of doing so, as for instance a split mandrel.

As to Figs. 1 to 6, *g* is the main-frame of a die-press, *h* is a horizontal shaft having a crank *i* adapted to move the rod *k* and a slide attached thereto up and down. To the said slide, a disk *n* similar to disk *d* of Fig. 7 is attached. This disk *n* is provided with levers *o o* pivoted at *p p* and having hooks *q q* which are adapted to grip under the annular projection *r* of a ring *s*. The lower edge of the latter has an annular projection *t* directed inwardly for holding the hollow body *a* together with the mandrel (Fig. 4) in position after the first degree of narrowing has been attained. I prefer to perform this first degree of narrowing, which, as mentioned above, does not require the use of a mandrel in another press of ordinary construction. At the bottom of the press, a table *u* is provided which can be rotated by hand and which carries five pairs of dies numbered 1 to 5. The diameters of the angular spaces 6 to 10 left by each of such pairs of dies, respectively, decrease gradually from 1 to 5. A catching device *v* which can be withdrawn by hand and corresponding recesses *w* in the edge of the table *u* are provided for holding the table in position. The pivot of the table *u* is arranged in such a way that the pairs of dies can be moved under the hollow body one after another on revolving.

The operation of the machine will be understood without further explanation, and it is obvious, that changes in the apparatus, within the scope of my invention, may be made without departing from the limits thereof.

What I claim as my invention and desire to secure by Letters Patent of the United States, is:

1. In a device of the character described, the combina-

tion with a fixed die consisting of an outer member and an inner member, of a holder adapted to carry a blank, and means for reciprocating the holder to force the blank into engagement with the die and to withdraw it therefrom.

5 2. In a device of the character described, the combination with a fixed die consisting of an outer member and an inner member separated from the outer member by an annular space having an enlarged mouth, of a holder adapted to carry a cup-shaped blank having an open end, and means for reciprocating the holder for the purpose of forcing the open end of the blank between the members of the die and for withdrawing it therefrom.

10 3. The combination with a series of graduated diameter decreaseers, of a holder adapted to carry a blank, means for reciprocating the holder, and a movable support for the diameter decreaseers adapted to be carried in position to bring any diameter-decreaseer of the series into alinement with the holder.

15 4. The combination with a holder adapted to carry a cup-shaped blank having an open end, of a rotatable series of graduated diameter decreaseers, means for reciprocating the holder to bring the open end of the blank into and out of engagement with the dies of the series as they are rotated, successively into alinement with the holder, and means for reinforcing the portion of the blank not operated upon by the dies.

20 5. The combination with a rotatable series of dies each die consisting of an outer member and an inner member, the latter separated from the former by an annular shaping space, the diameter of the shaping space increasing throughout the series of dies, of a holder consisting of a base and a ring detachably connected thereto the ring having an inwardly projecting rim the holder being adapted to carry a cup-shaped blank having an open end of lesser diameter than its closed end, the closed end being seated against the base of the holder and the shoulder formed by the reduction of the blank, being engaged by the rim of the ring of the holder, a cross-head carrying the holder, a pitman attached to the cross-head, and means adapted to reciprocate the pitman for the purpose of carrying the open end of the cup-shaped blank into and out of engagement

with the dies as they are brought into alinement with the holder.

6. The combination with a rotatable table; of means adapted to lock the table in operative position; a graduated series of dies carried by the table each die consisting of an outer member and an inner member, the latter separated from the former by an annular space having an enlarged mouth; of a holder adapted to carry a cup-shaped blank having an open end the holder consisting of a base, hooks carried by the base, and a ring detachably carried by the hooks; a cross-head and pitman; a crank-shaft adapted to operate the pitman; a gear carried by the crank-shaft; a counter-shaft; a gear on the counter-shaft in mesh with the gear on the crank-shaft; a second gear on the counter-shaft; a driven shaft; a gear on the driven shaft in mesh with the second gear on the counter-shaft; a clutch on the driven shaft; and means on the driven shaft for receiving power.

7. A holder consisting of an annular recessed head, hooks pivoted thereto, and an annular ring detachably supported by the hooks and having an inwardly projecting rim.

8. A die consisting of an outer hollow cylindrical member having its bore increased at one end by an annular flaring recess terminated by an annular recess having a rounded end, and an inner cylindrical member positioned within the bore of the outer member and separated from the inner periphery of the latter.

9. The combination with a rotatable table, of a series of dies carried by the table each die consisting of an outer member and an inner member separated from the outer member by an annular space the diameter of the annular space varying in order throughout the series.

In testimony whereof I have signed my name to this specification in the presence of two subscribing witnesses.

HERMANN KOHL.

Witnesses:

W. FRHR VON LYNCKER,
CARL SCHMITT.