



(19) United States

(12) Patent Application Publication
Garnett et al.

(10) Pub. No.: US 2003/0105859 A1

(43) Pub. Date: Jun. 5, 2003

(54) INTRUSION DETECTION

Related U.S. Application Data

(76) Inventors: Paul J. Garnett, Camberley (GB);
James E. King, Wokingham (GB);
Martin P. Mayhead, Hindhead (GB)

(60) Provisional application No. 60/311,505, filed on Aug. 10, 2001. Provisional application No. 60/366,430, filed on Mar. 21, 2002.

Publication Classification

Correspondence Address:
B. Noel Kivlin
Meyertons Hood, Kivlin, Kowert & Goetzel, P.C.
P.O. Box 398
Austin, TX 78767-0398 (US)

(51) Int. Cl.⁷ G06F 15/173
(52) U.S. Cl. 709/224; 709/225

(57) ABSTRACT

A server blade may comprise a processor and a network interface. The network interface can be configured be connected to a network remote the server blade. The server blade may be configured to detect an access to the network. The server blade may be further configured as a field replaceable unit. Optionally, the server blade may further comprise an enclosure which encloses the processor.

(21) Appl. No.: 10/215,663

(22) Filed: Aug. 9, 2002

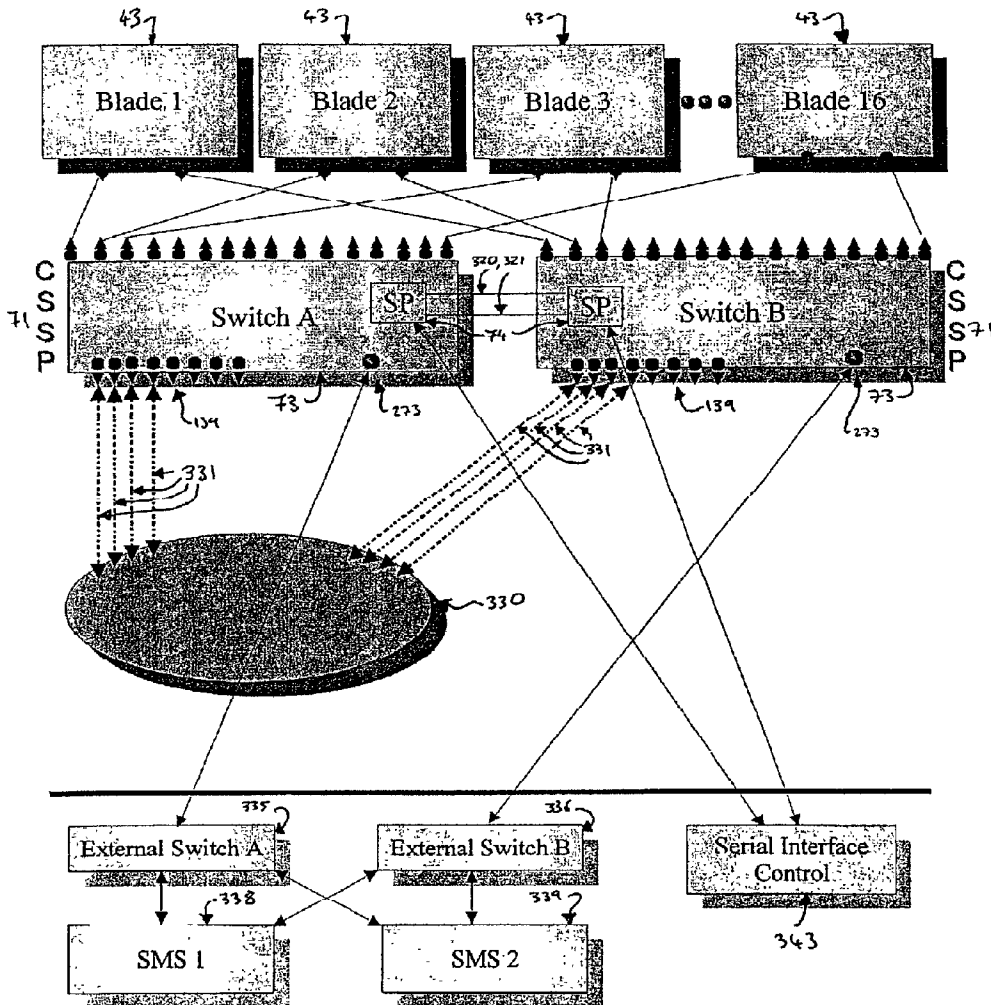

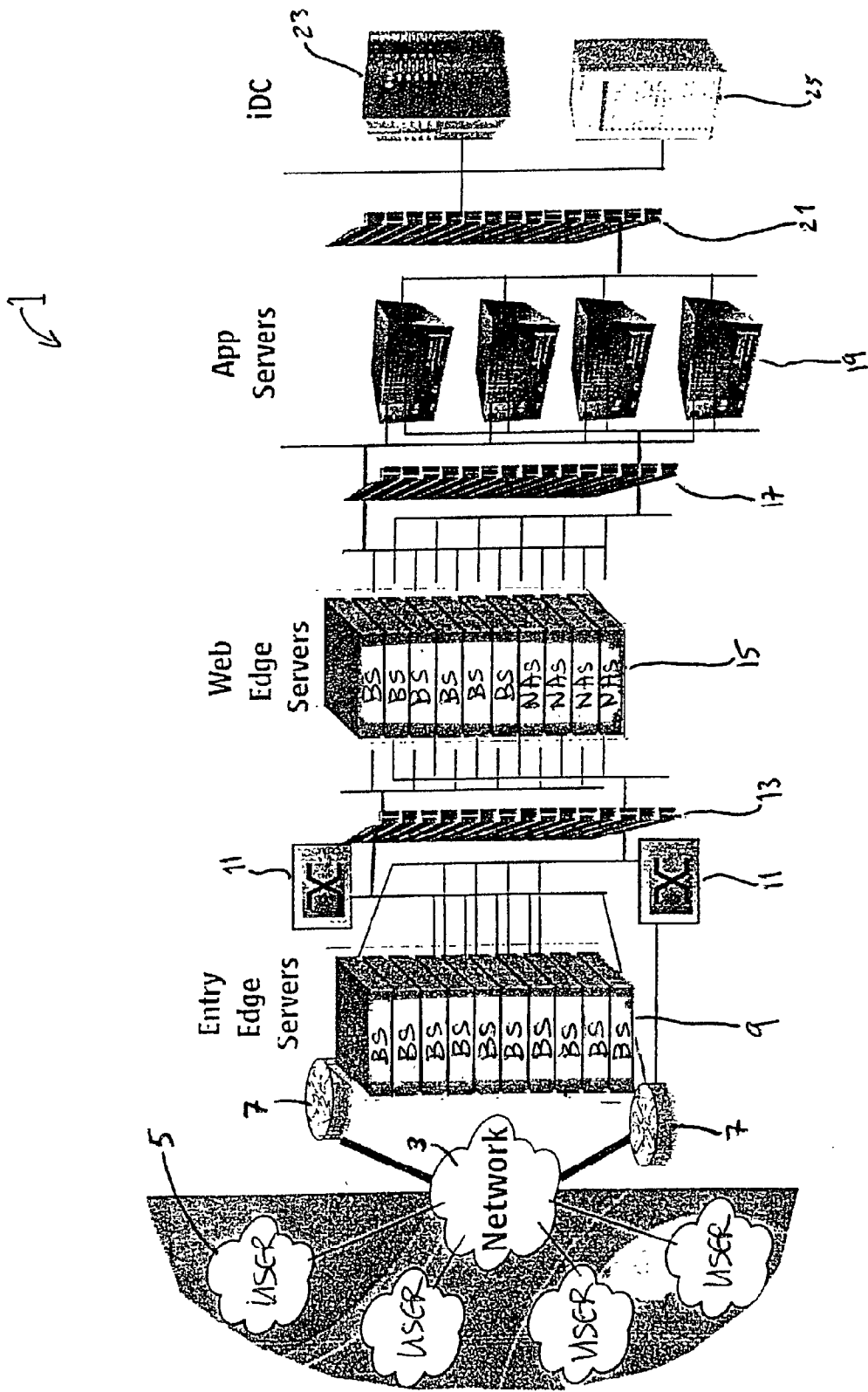

FIG 1

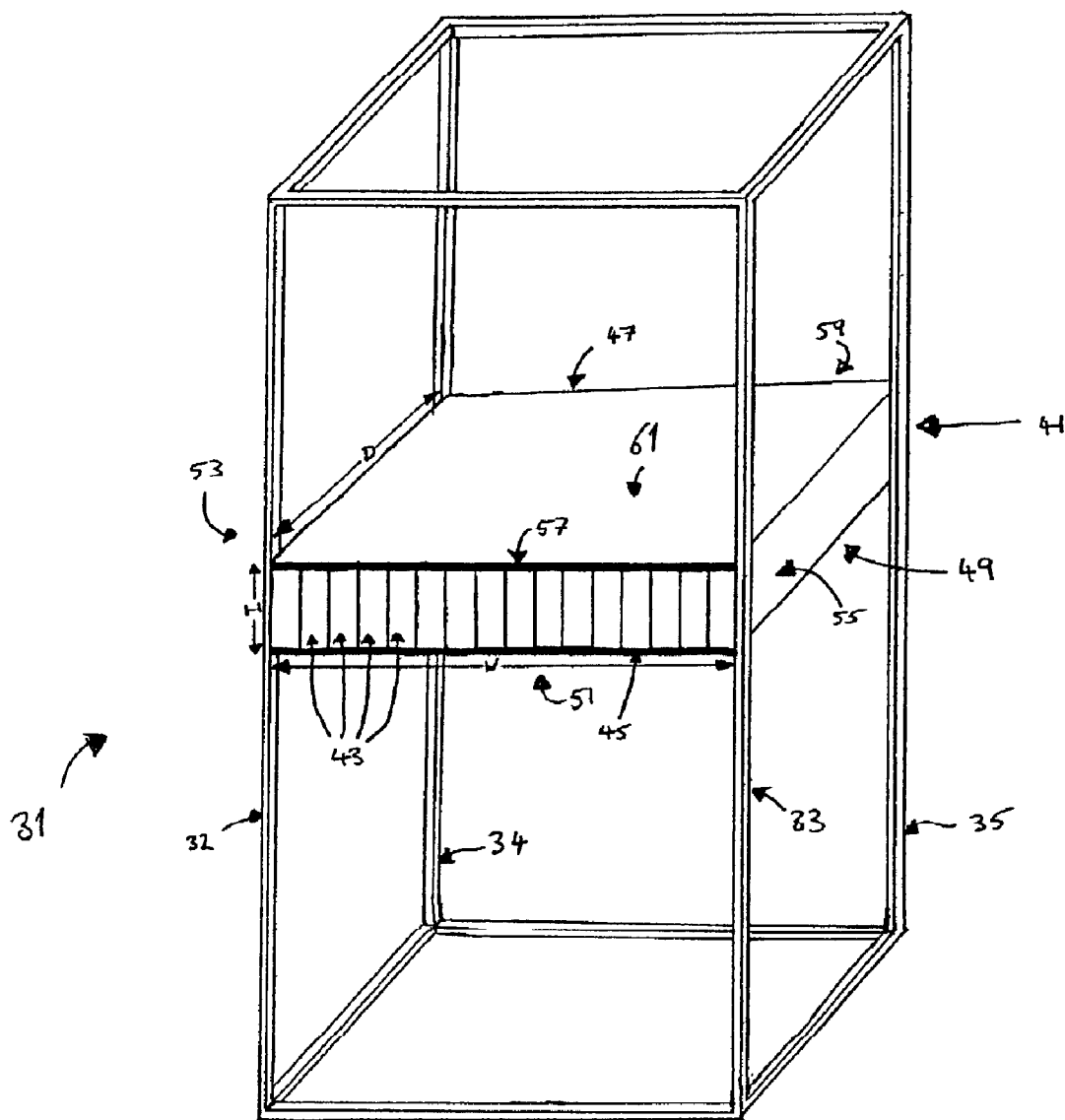
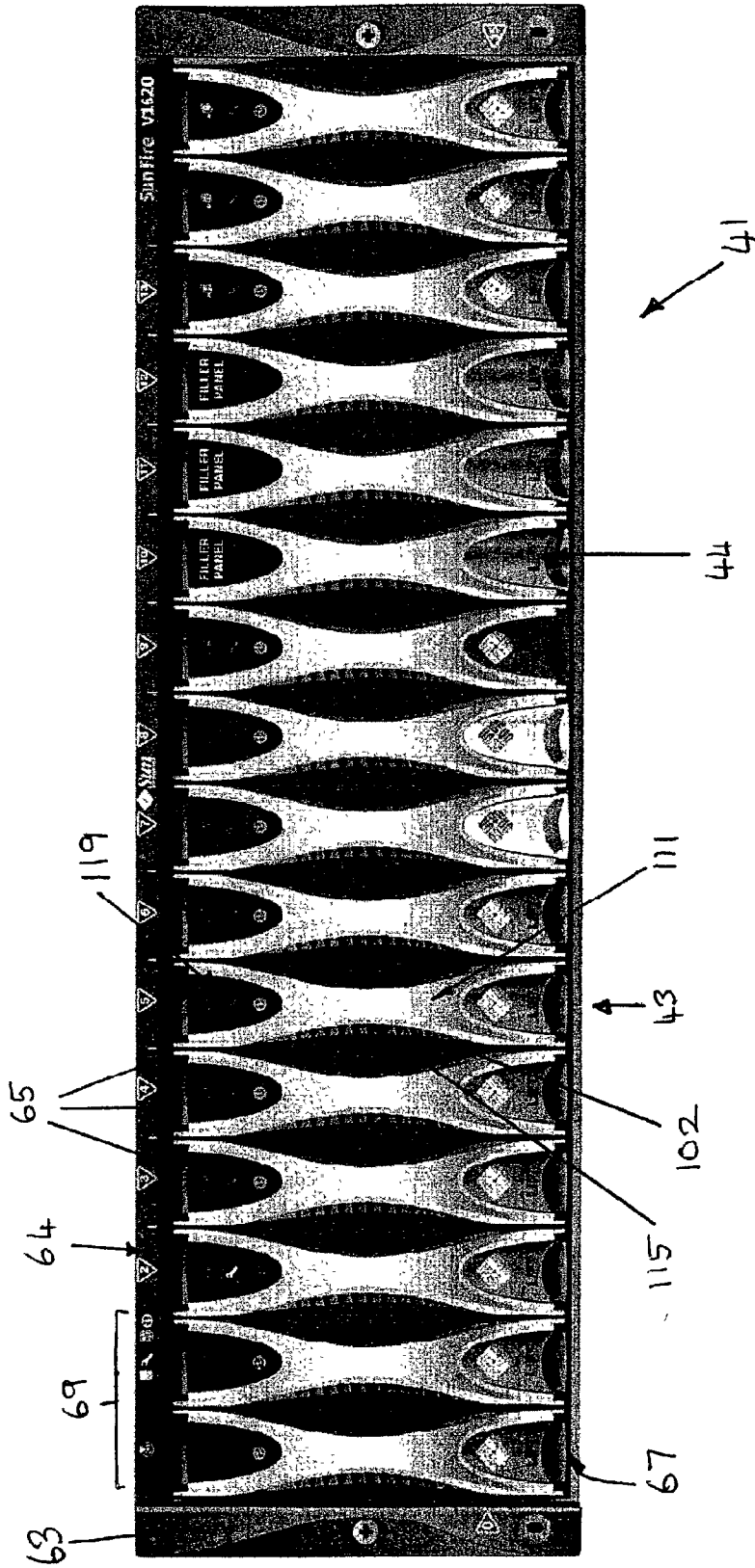

FIG 2



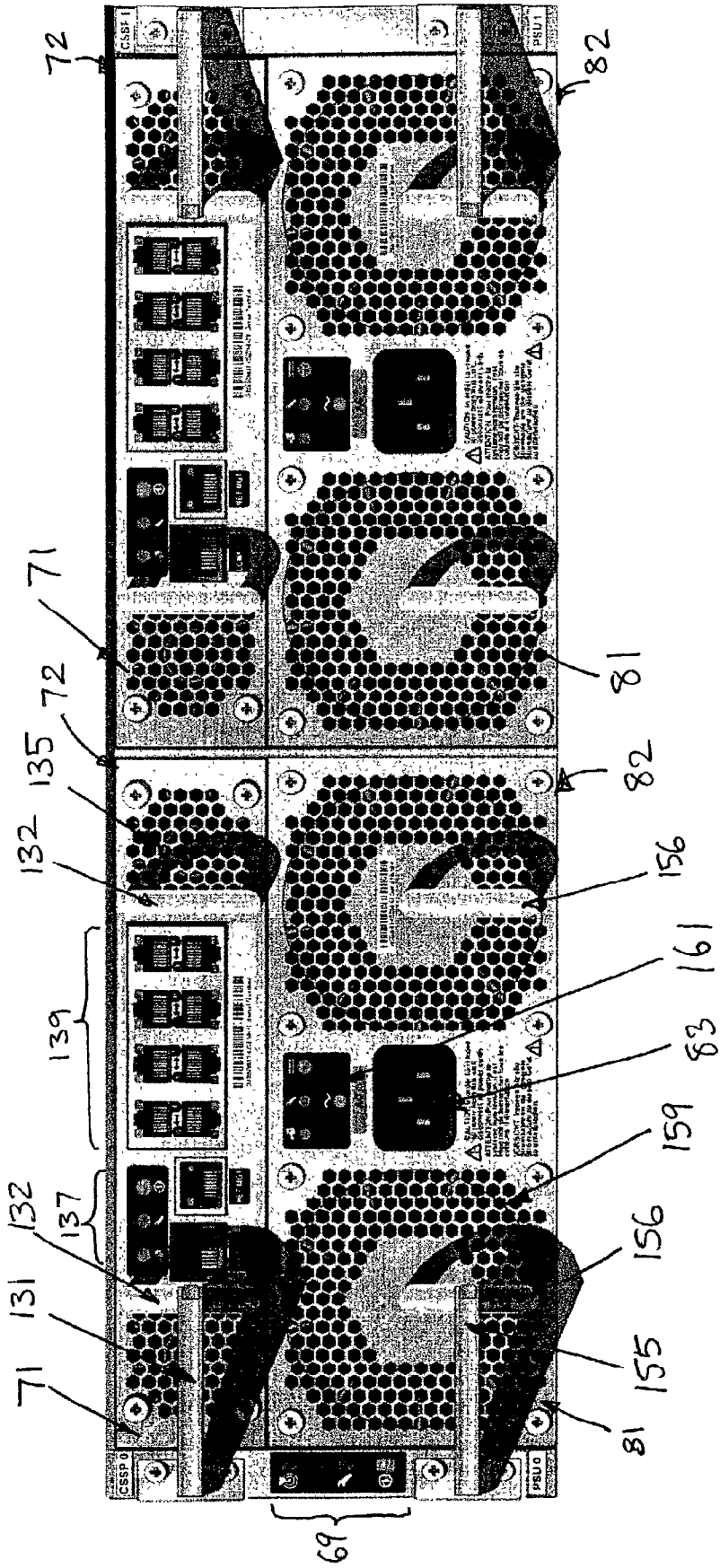

FIG 4

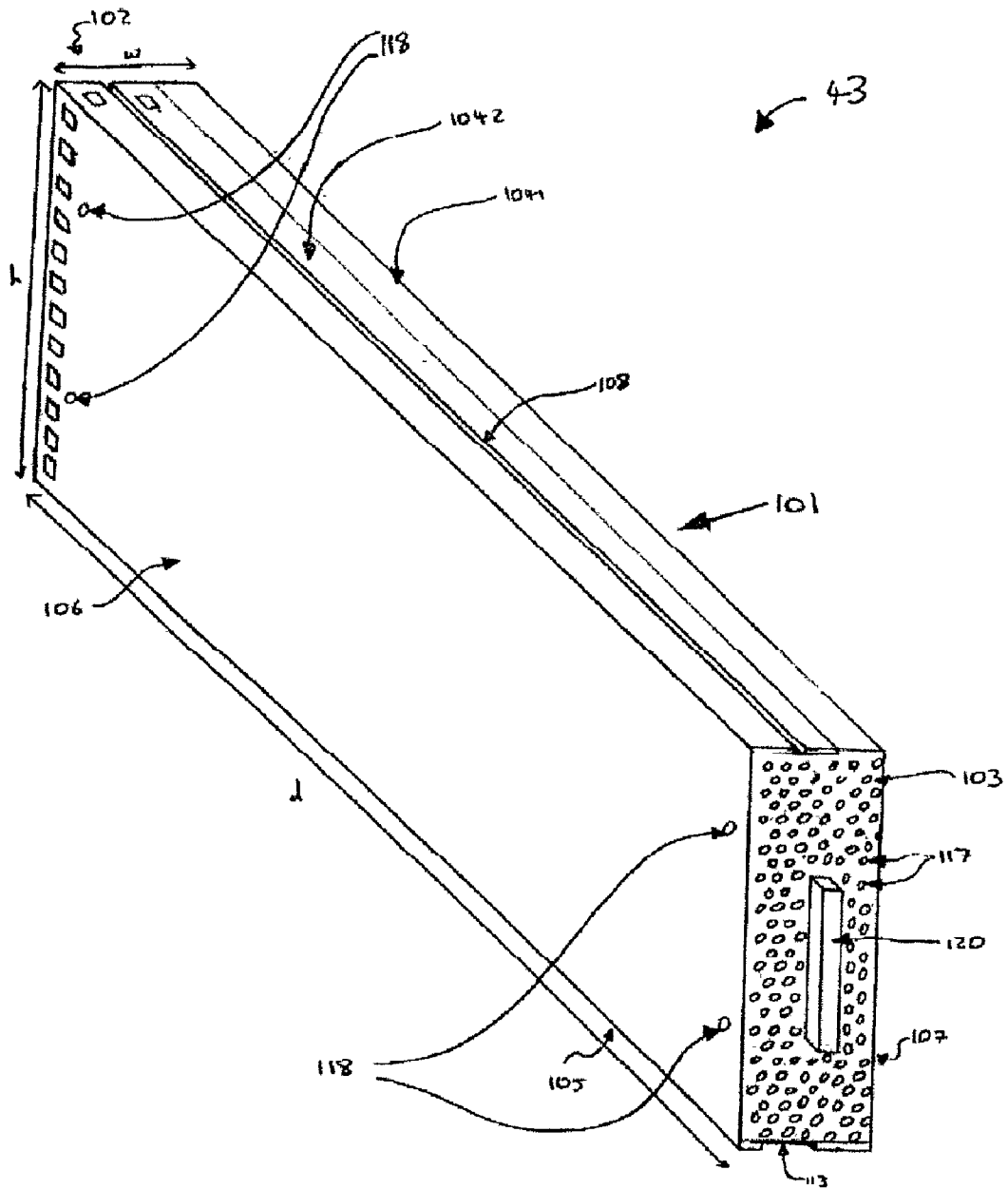

FIG 5A

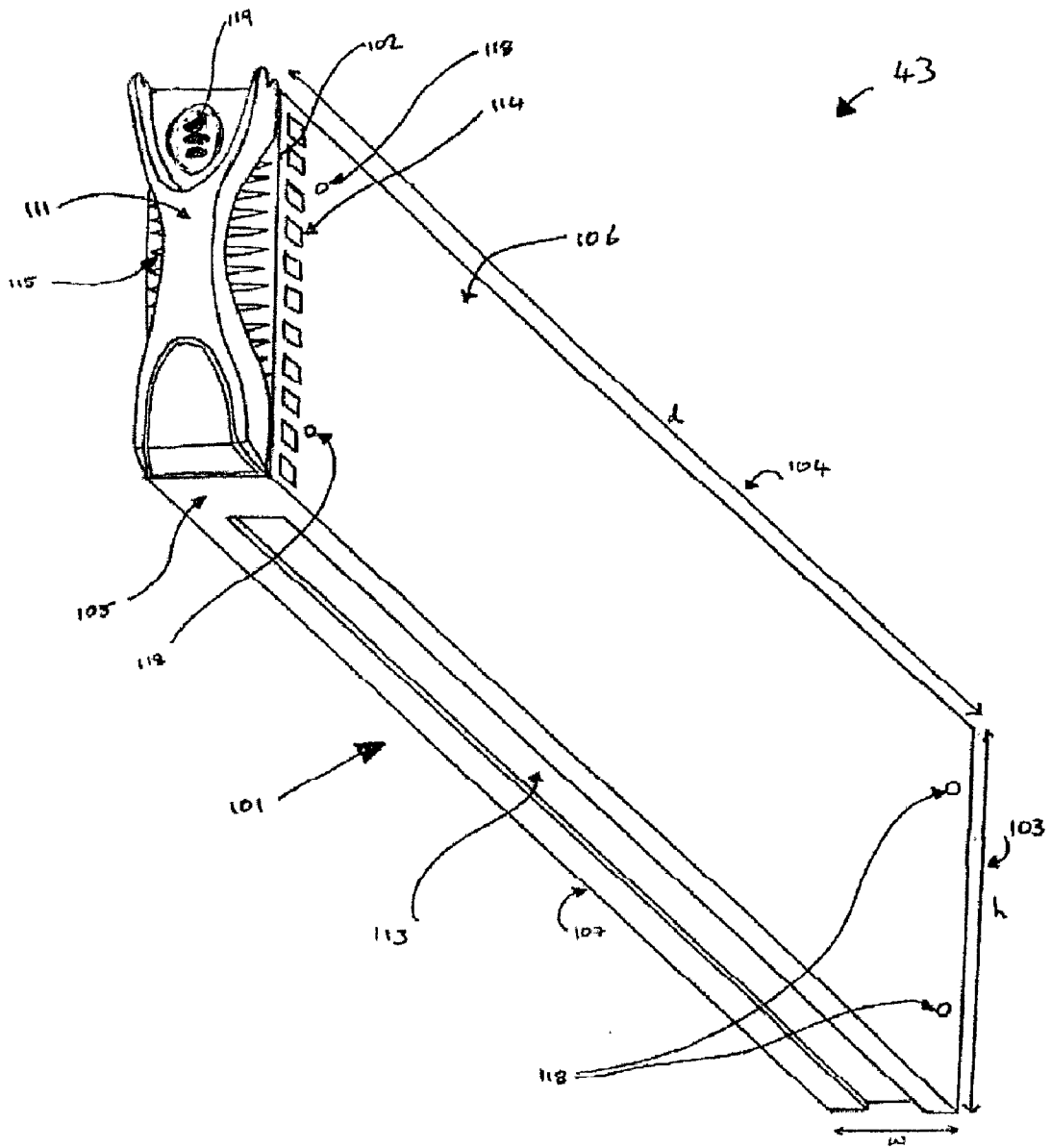

FIG 5B

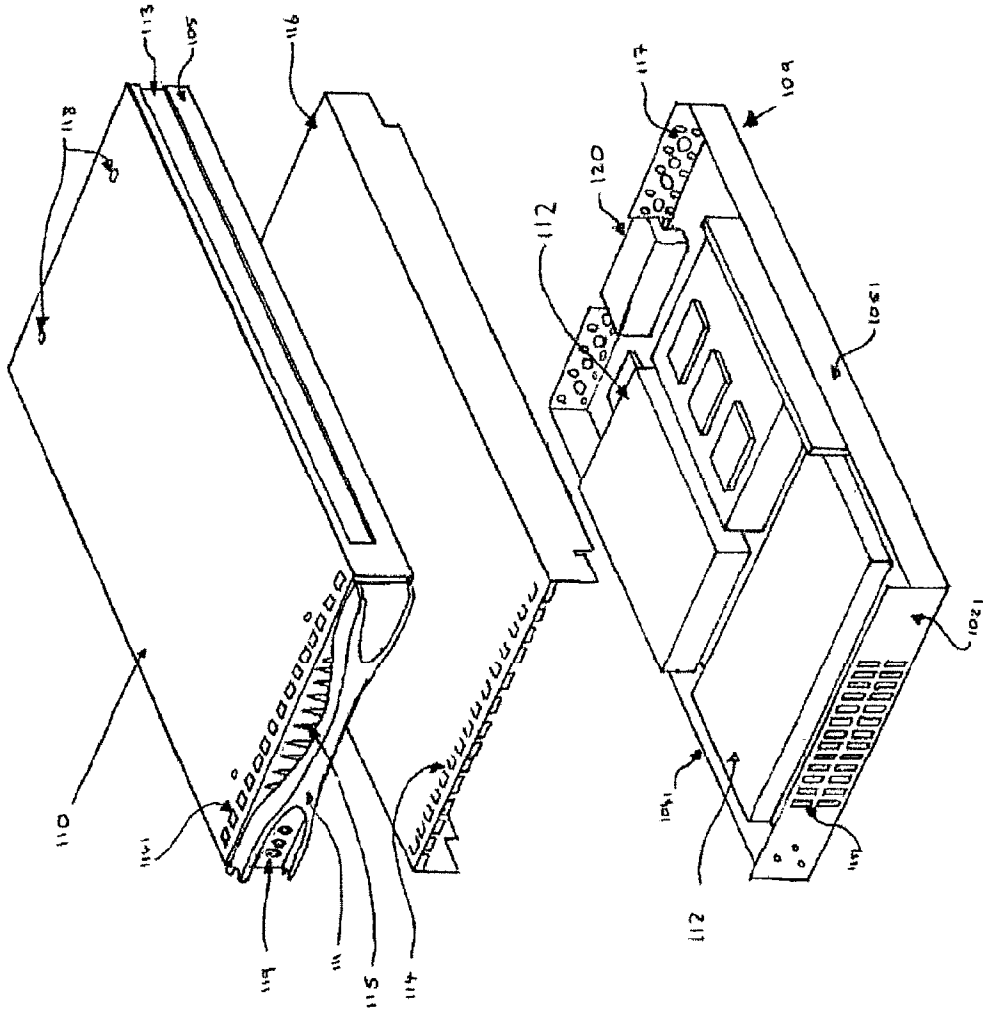

FIG 5C

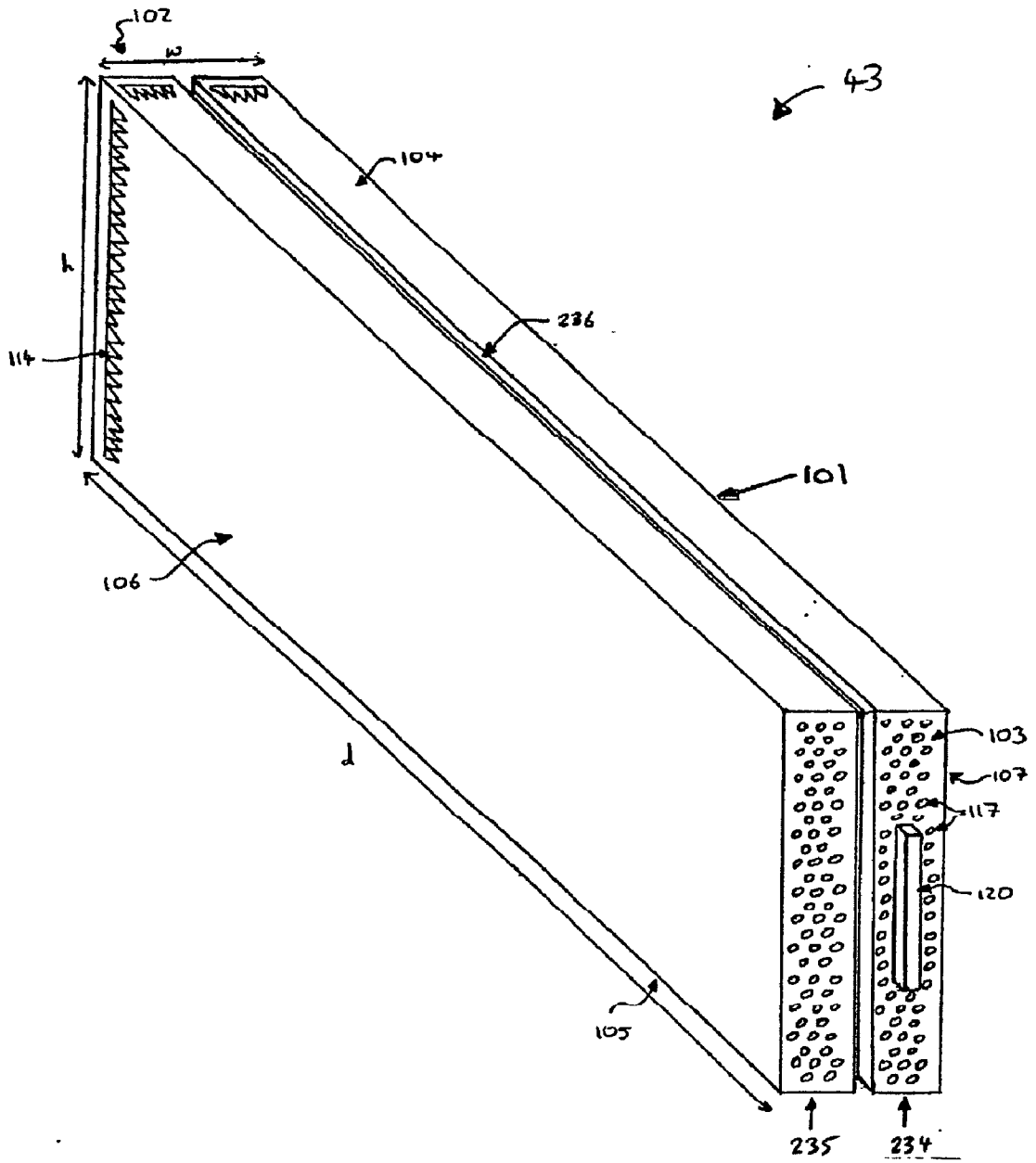

FIG 50

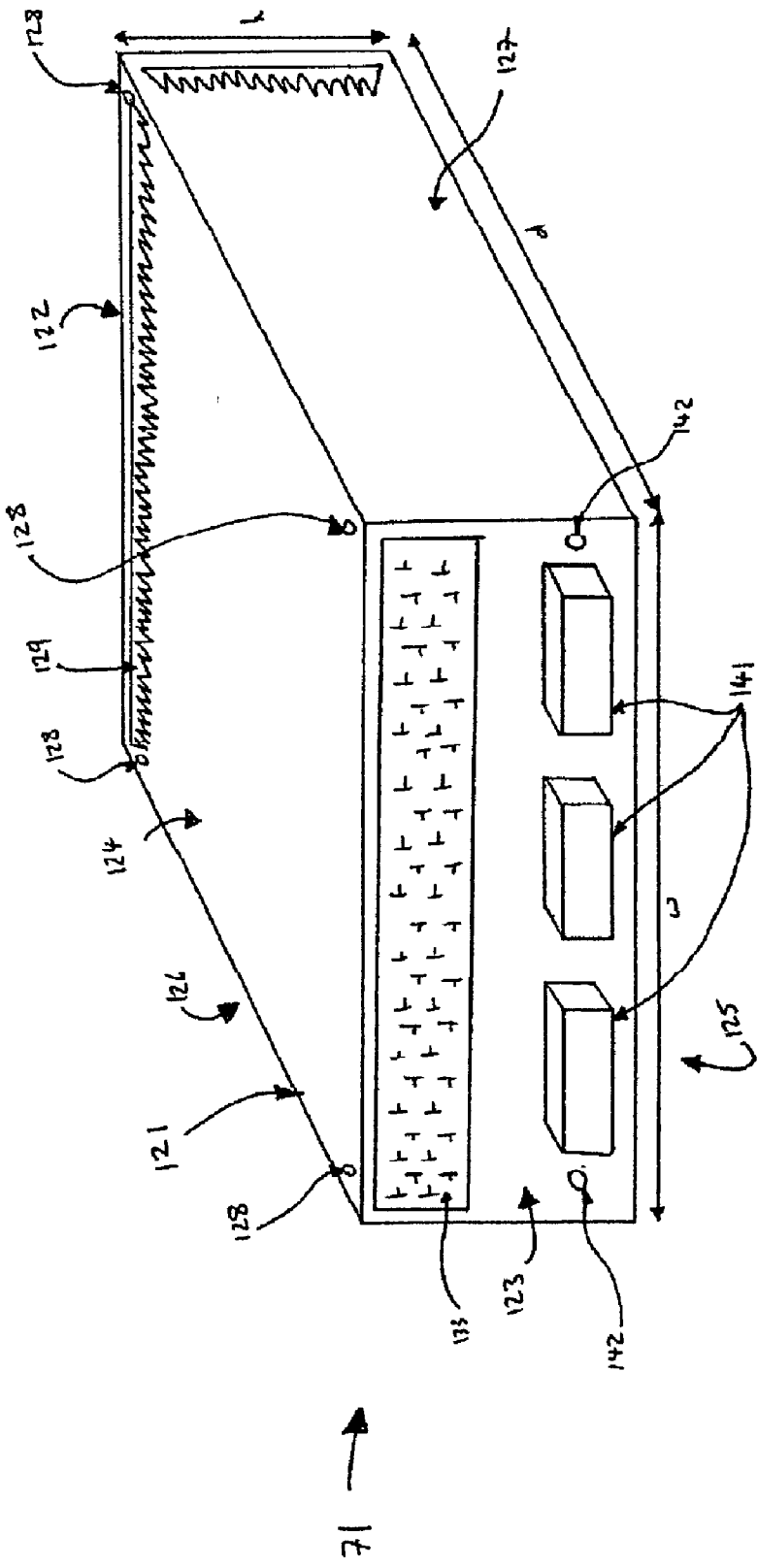

FIG 6

21FAR

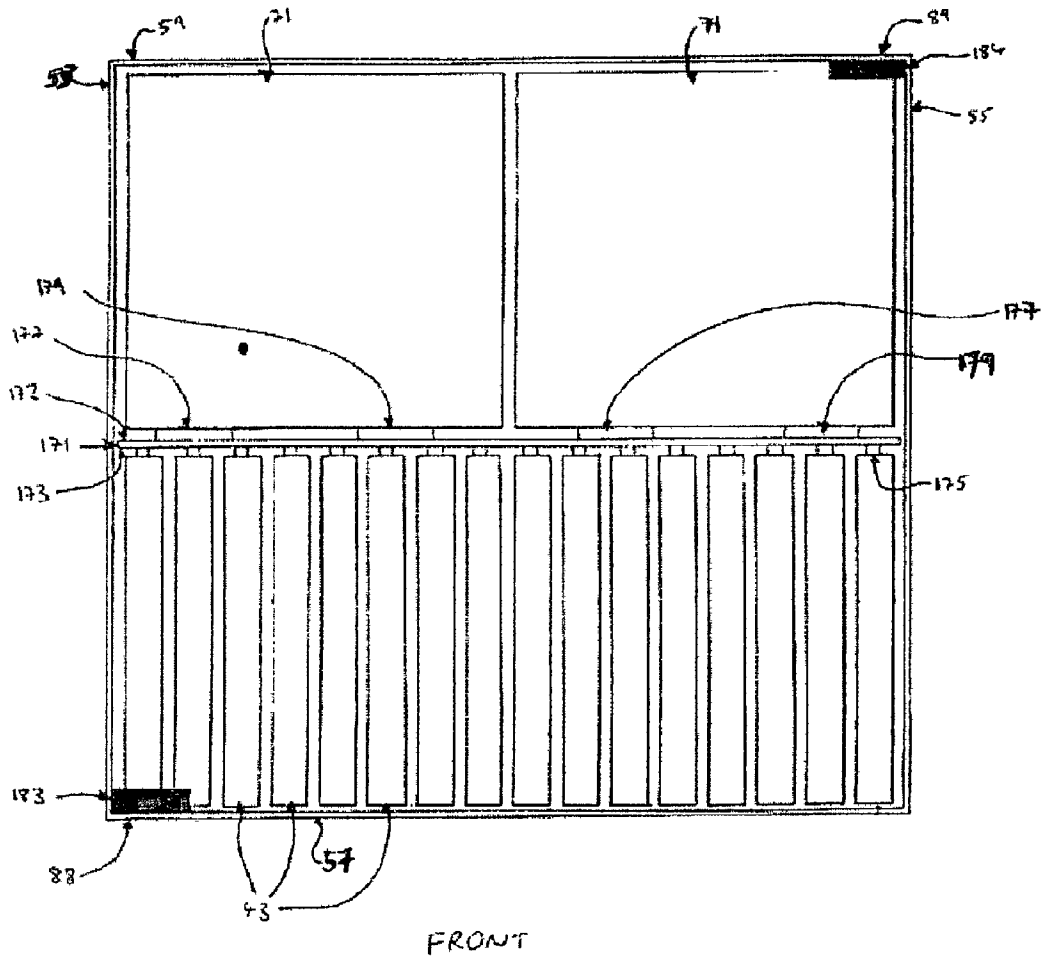

FIG 8A

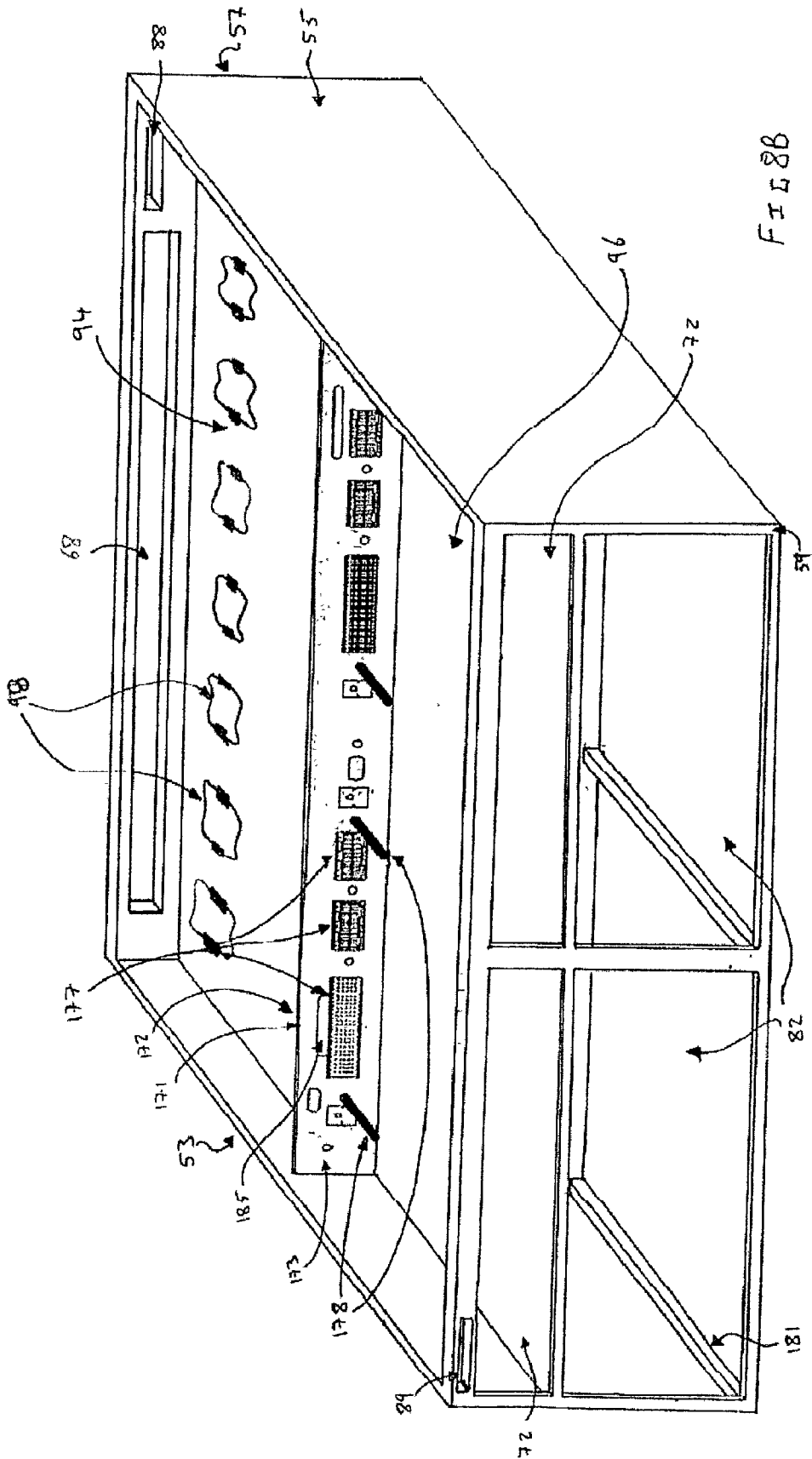
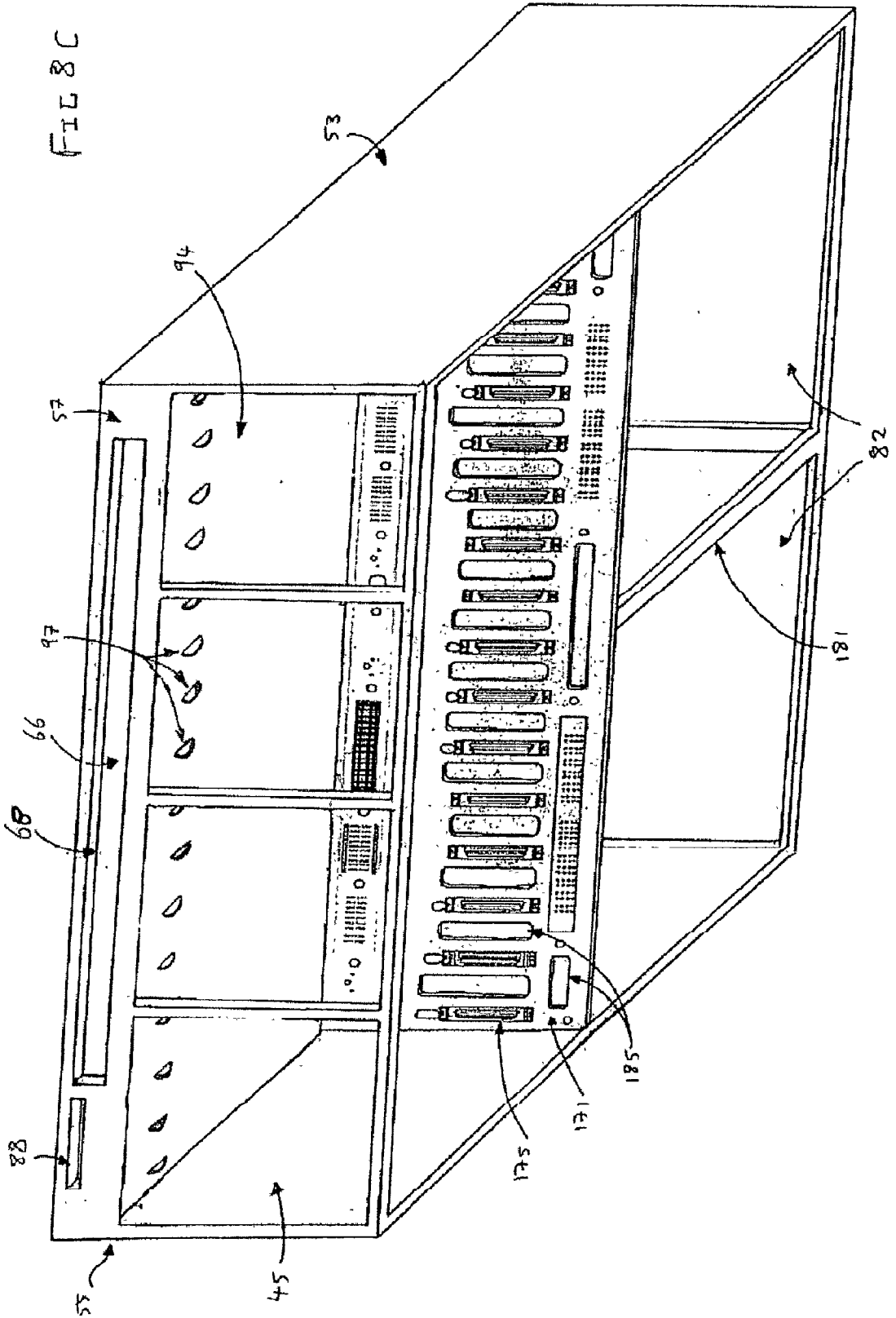

FIG. 8B



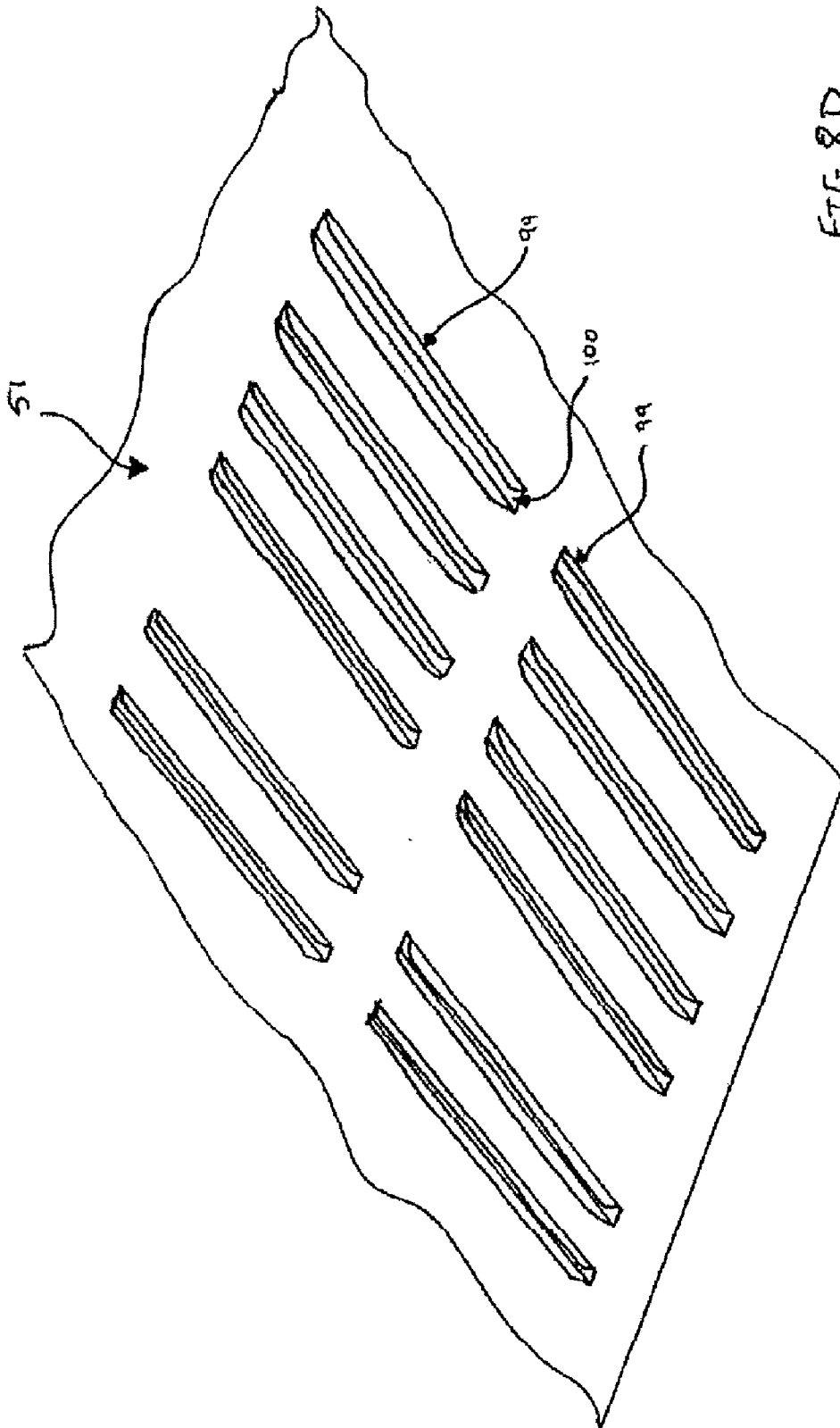

FIG 8D

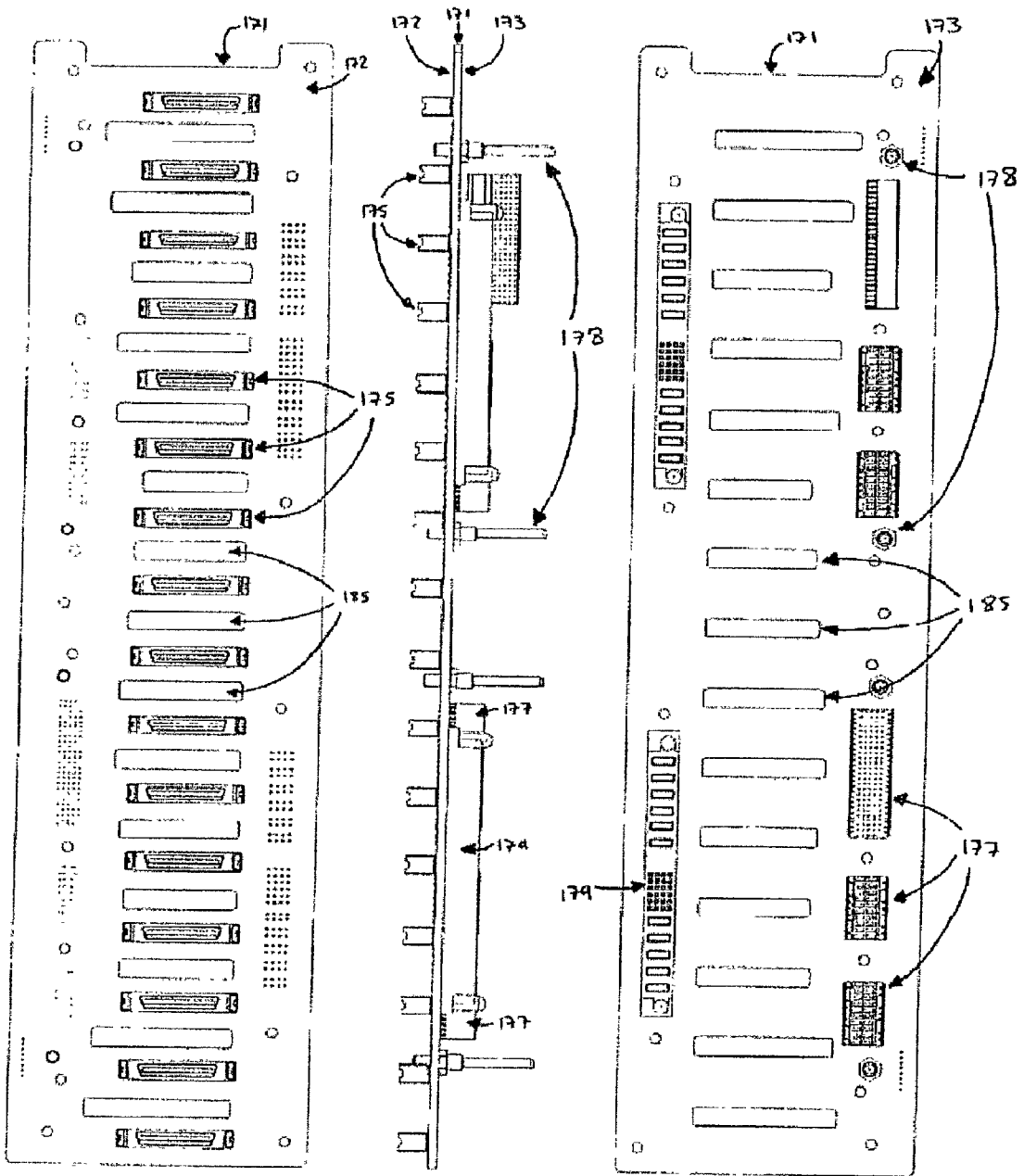
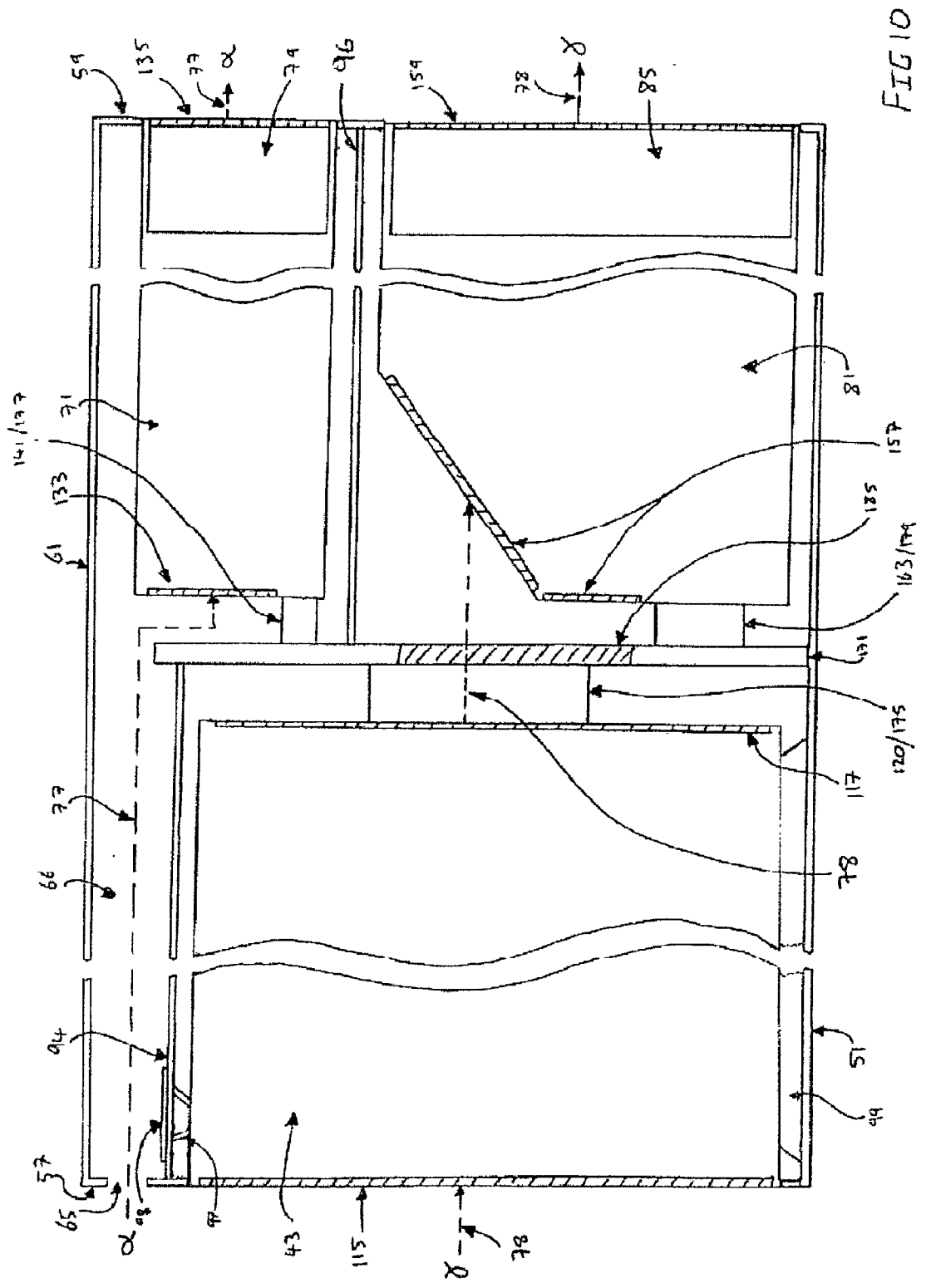
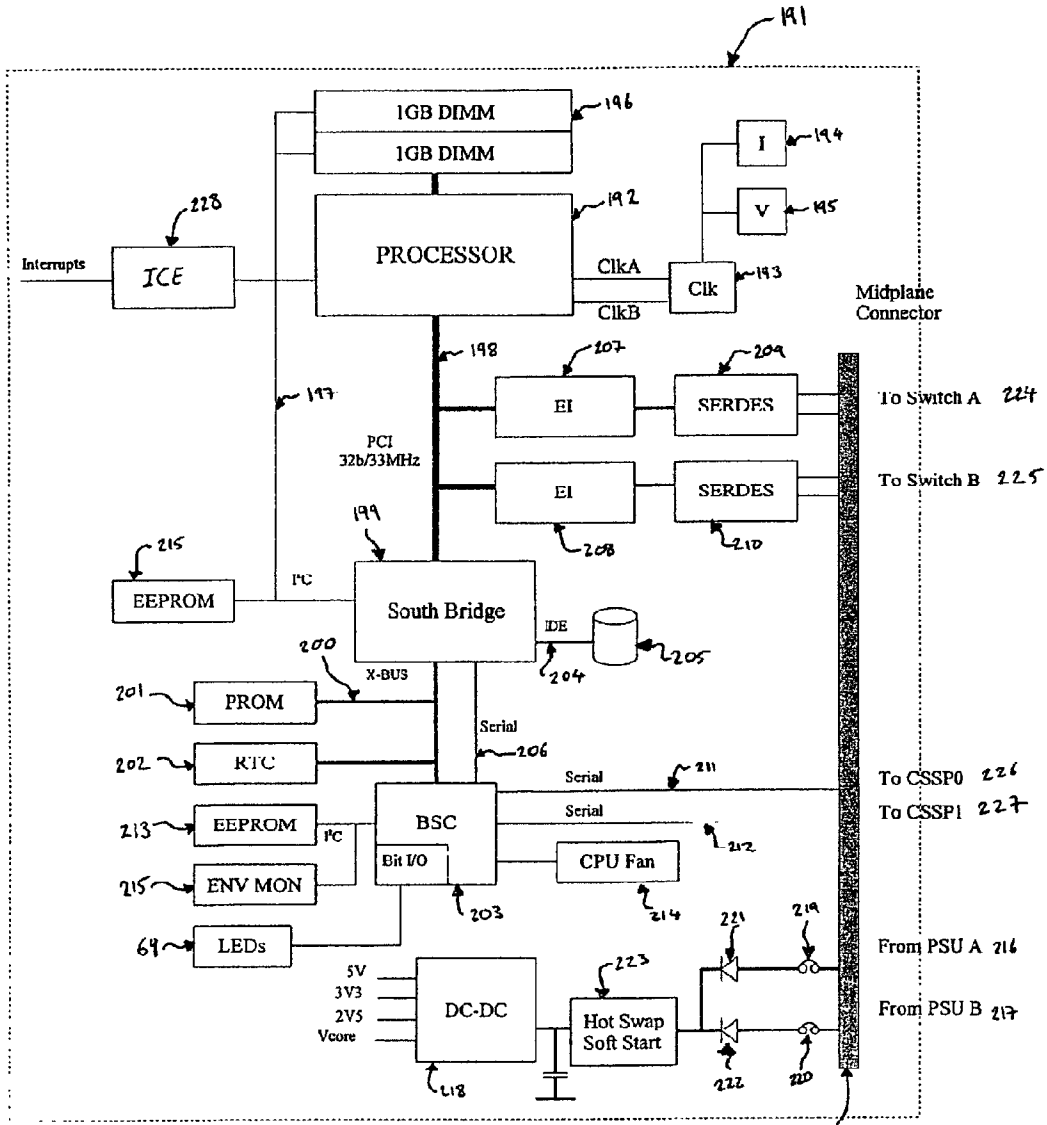

FIG 9A

FIG 9B

FIG 9C





43 ↗

FIG 11

120

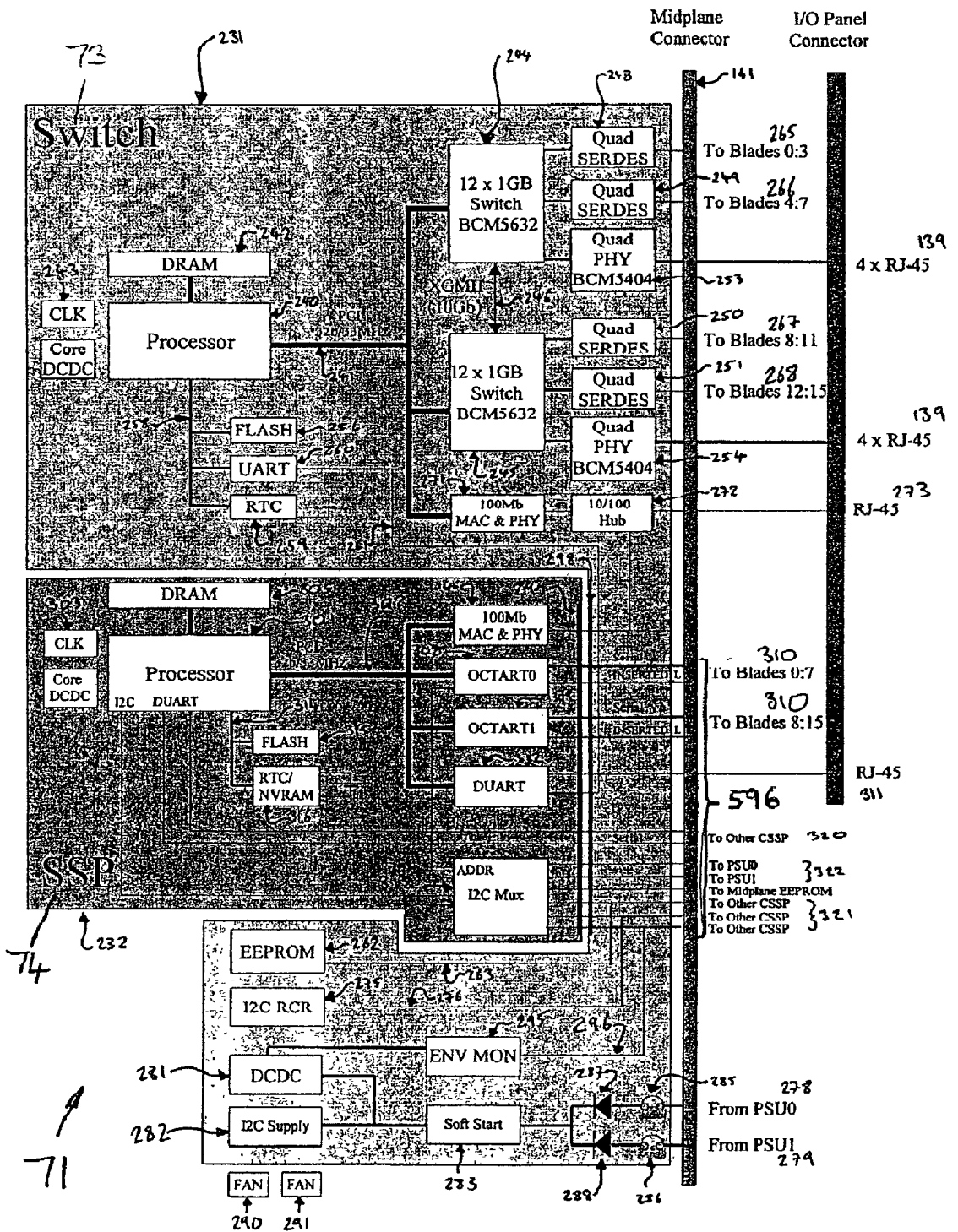

FIG 12

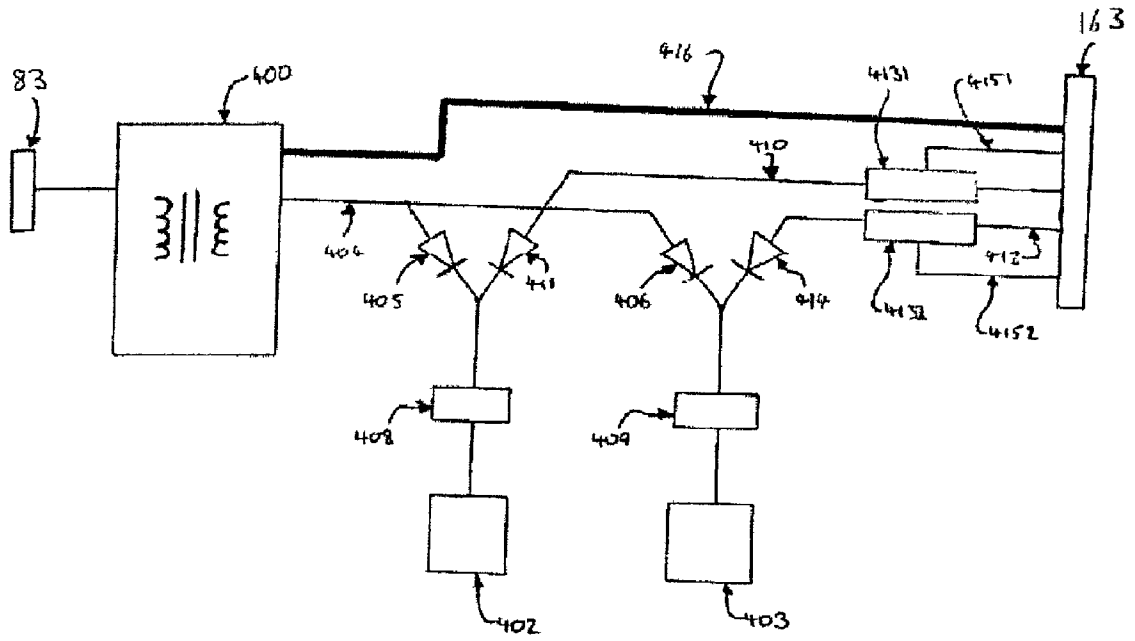

FIG 13

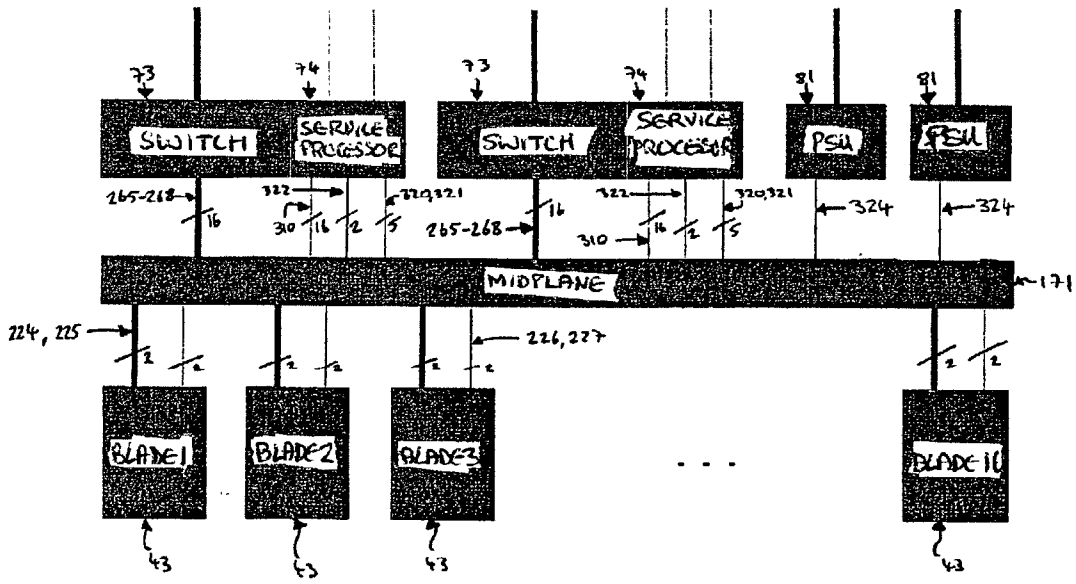

FIG 14

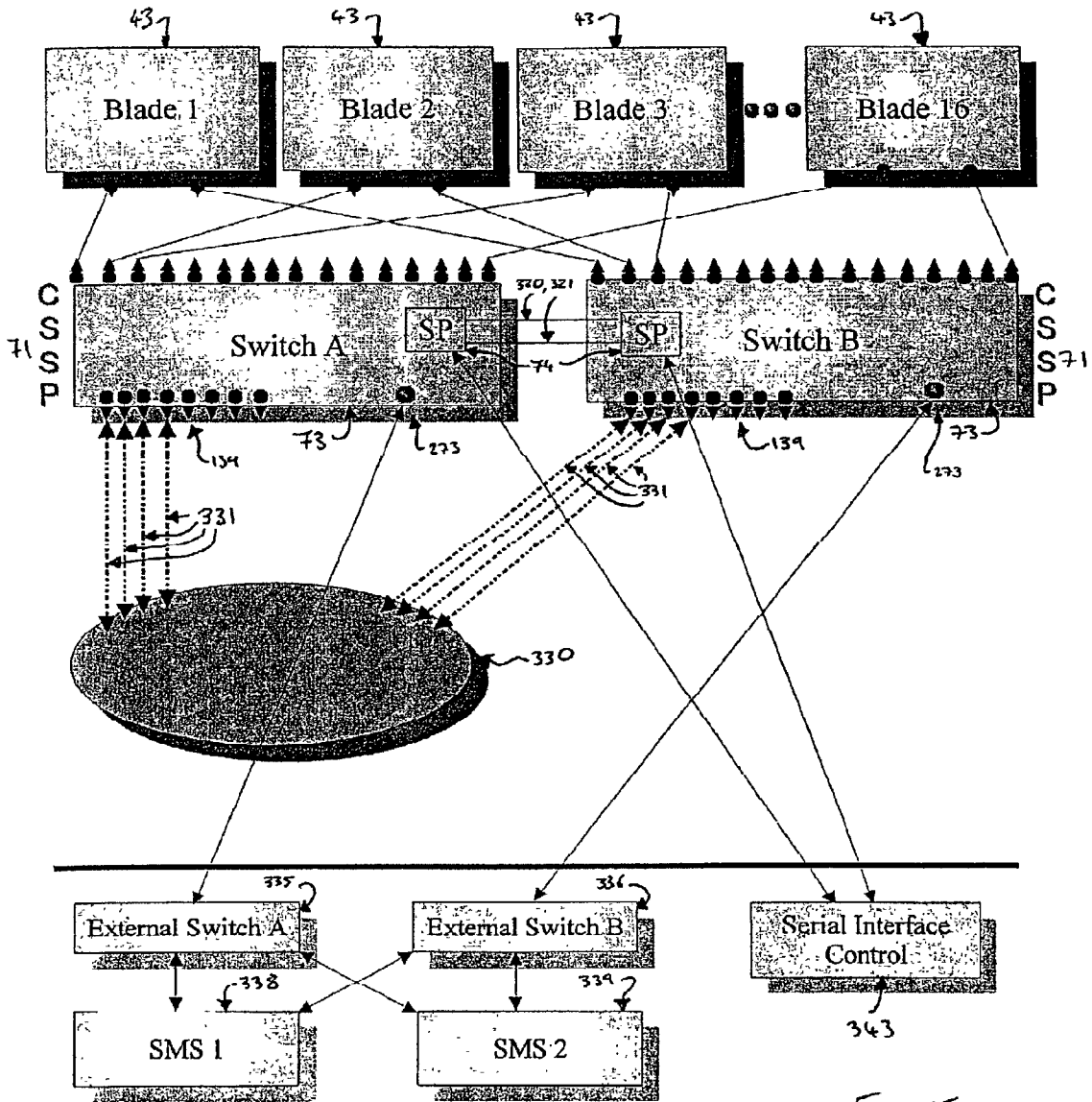

FIG 15

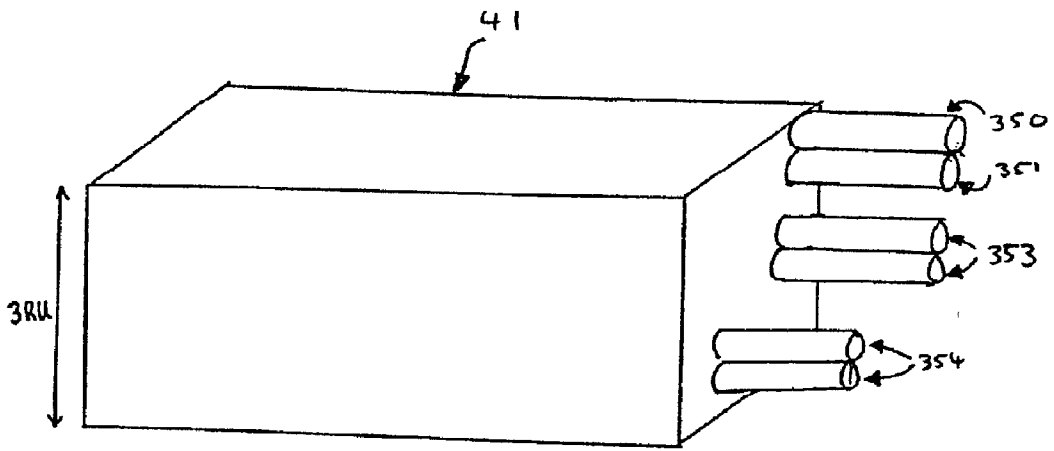

FIG 16

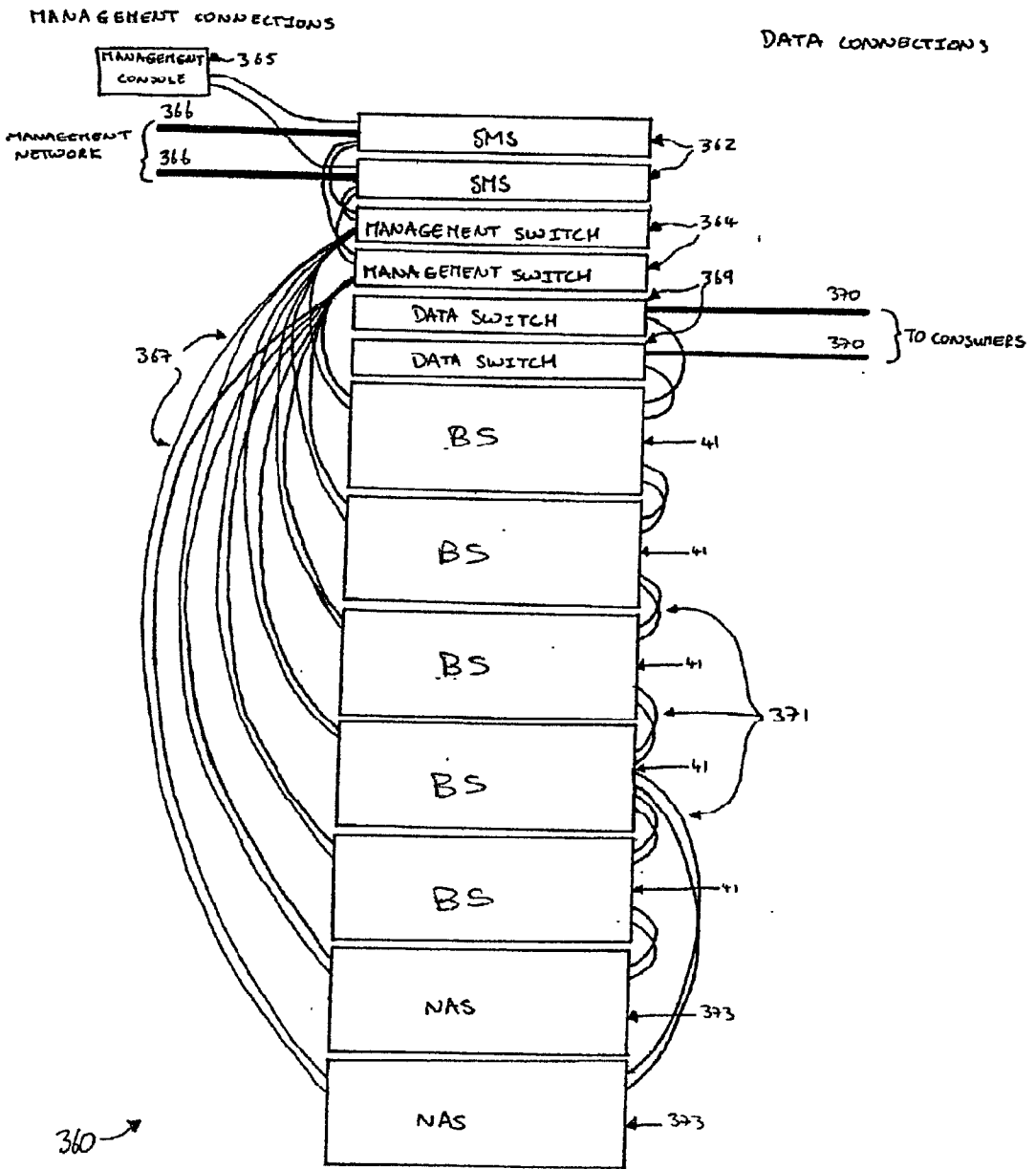

FIG 17

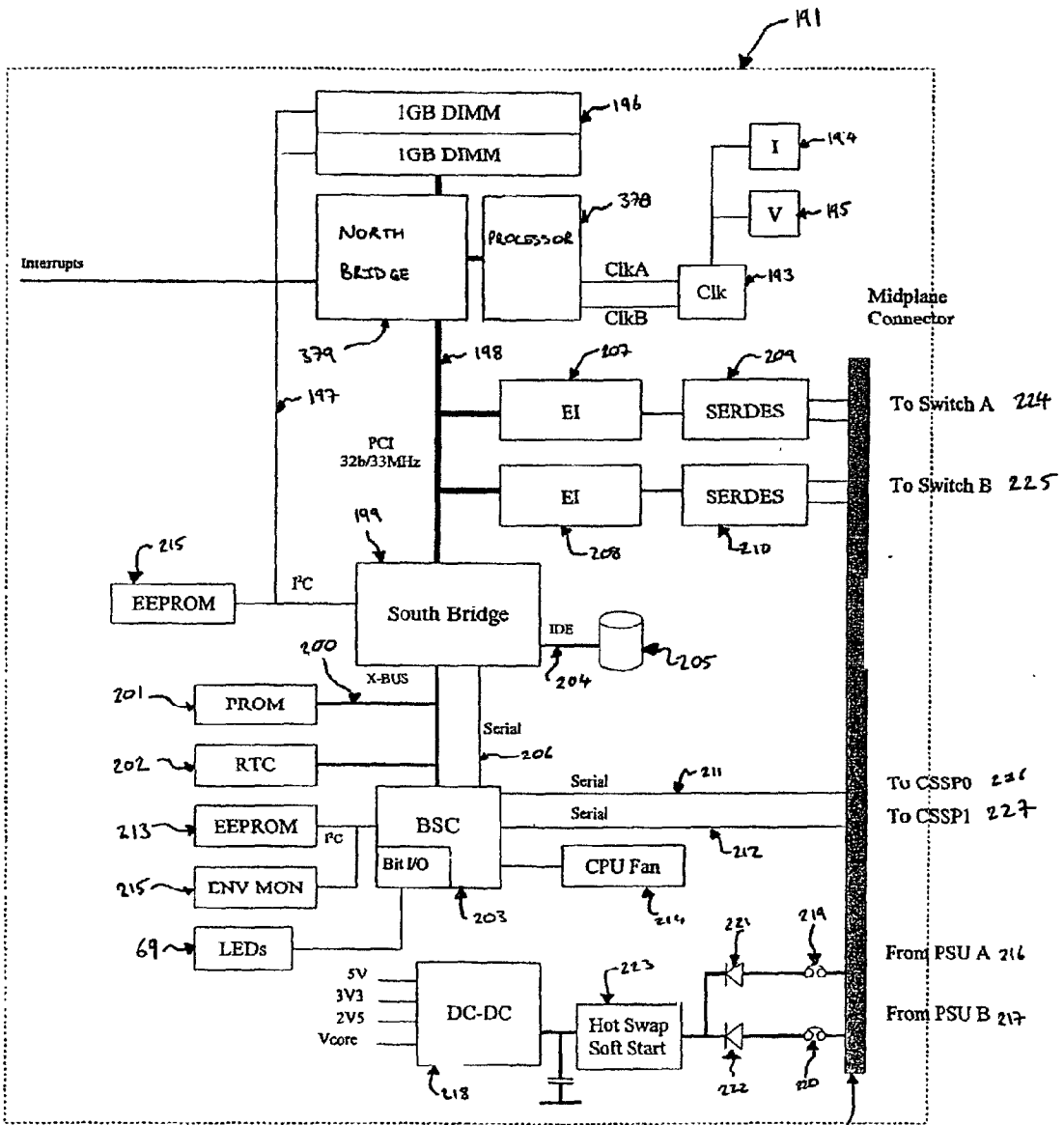

FIG 18

43

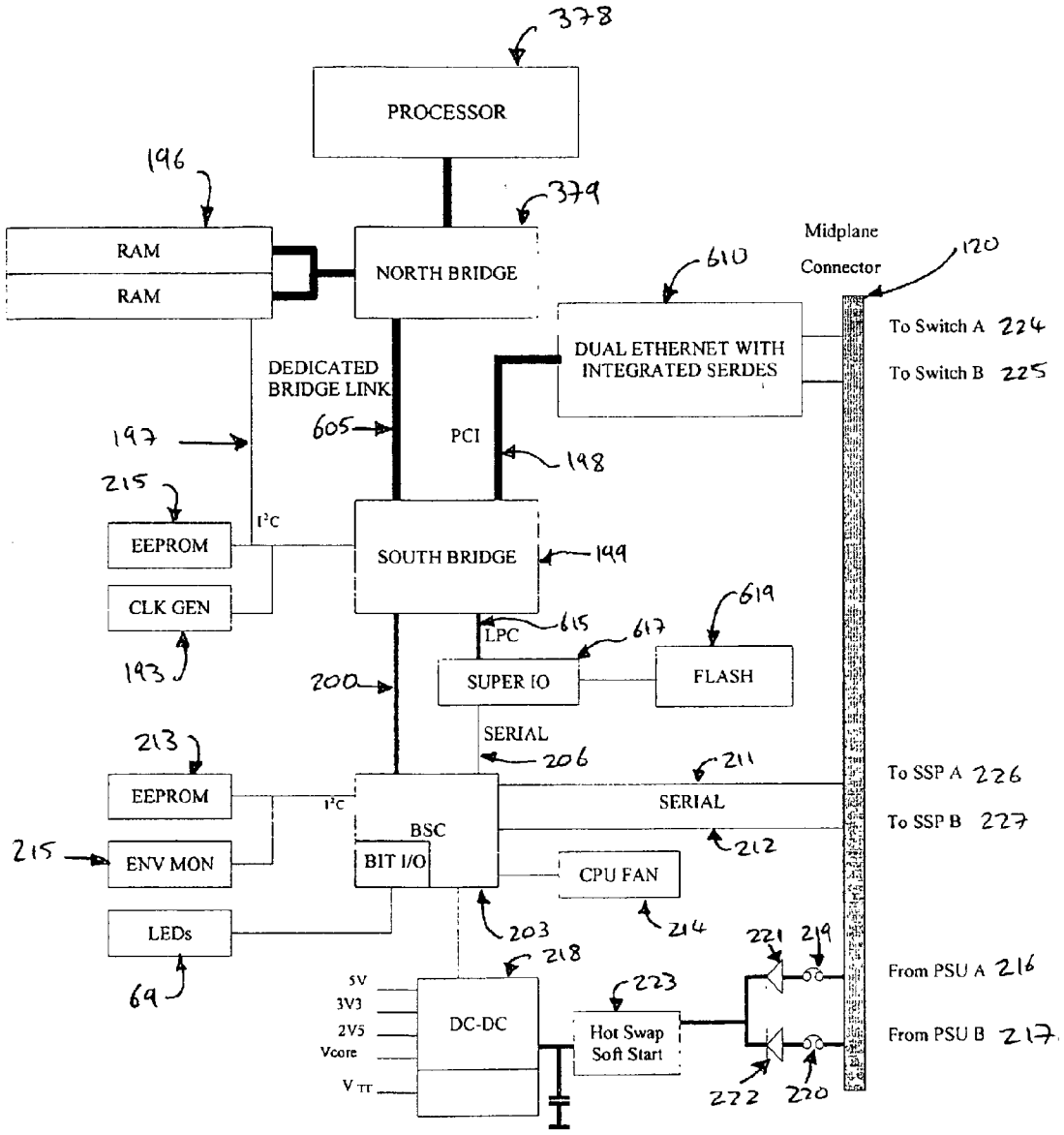

FIG 19

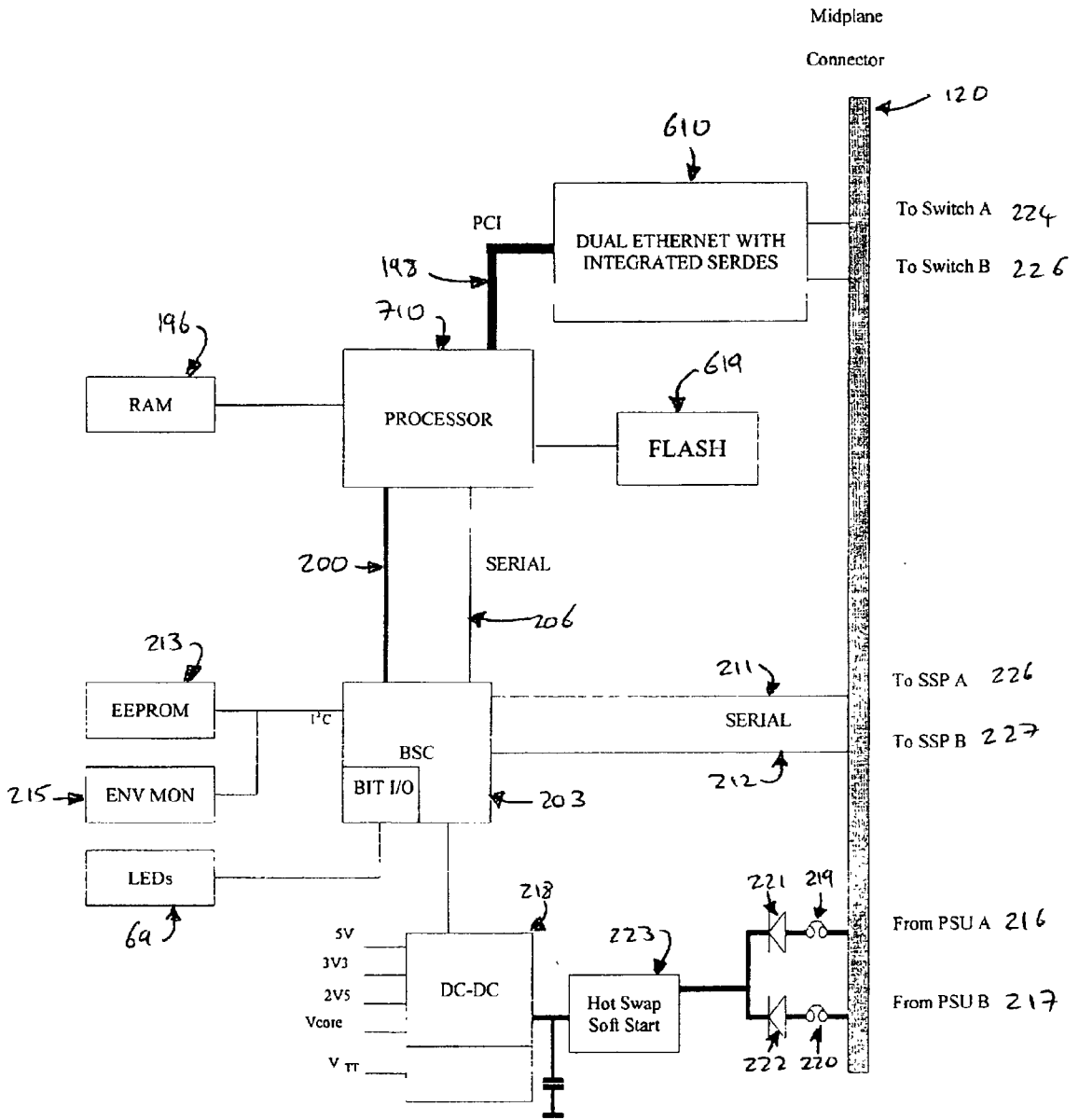

FIG 20

INTRUSION DETECTION

BACKGROUND OF THE INVENTION

[0001] The present invention relates to computer systems, in particular to intrusion detection systems for multi-processor systems, for example multi-processor server systems.

[0002] One application for the present invention relates to high density computer systems, for example, computer server systems for telecommunications applications. In telecommunications applications, it is important to provide high reliability and high capacity of operation. Various approaches have been taken to providing such high-performance, high reliability systems. Typically such systems are designed around providing redundant resources so that if one component of the system develops a fault, the system remains operational using the redundant resources. Fault tolerance can also be achieved, for example, with multiprocessor systems that provide redundancy through dynamic, e.g., software-controlled, task distribution. High density systems are typically rack mountable, with one or more processor systems occupying a shelf in the rack. The trend in recent times is to make the computers with smaller form factors. This means that more computers can be located in a rack. This has the advantage of increasing the processing density within the racks, and also the advantage of reducing the distance between the computer systems.

[0003] The present invention relates to the detection of intrusions into a networked higher density computer system.

[0004] In situations where a group of individual computer systems (such as servers) are connected to work co-operably with one another, monitoring for and detection of unauthorized intrusions into the network of individual elements may substantially boost the operating security, reliability and availability of the group of computer systems many times over.

SUMMARY OF THE INVENTION

[0005] A first aspect of the invention may provide a server blade. The server blade may comprise a processor and a network interface. The network interface can be configured to be connected to a network remote the server blade. The server blade may be configured to detect an access to the network. The server blade may be further configured as a field replaceable unit. The server blade of this arrangement may therefore perform an intrusion detection function for a blade computer system from within the system, thereby providing an efficient and secure intrusion detection function. Thus the operational reliability, security and availability of the computer system may be enhanced.

[0006] Optionally, the server blade may further comprise an enclosure which encloses the processor. Thereby the server blade may be made resilient and handling thereof may be performed with reduced care and attention and may be performed by an unskilled worker.

[0007] A further aspect of the invention may provide a modular computer system. The modular computer system may comprise a carrier operable removably to receive a plurality of computer system modules therein and a plurality of information processing modules removably received in the carrier, each module having a communications port operable to connect to a communications network internal to

the carrier. The modular computer system may also comprise a switch operable to connect to the internal communications network to distribute information messages between the modules and to connect to an external communications network; and an access detection module removably received in the carrier. The access detection module may be operable to connect to the internal communications network to detect an access to the internal communications network. This arrangement provides a modular computer system having an intrusion detection facility integral thereto to enable secure and efficient operation of the system.

[0008] Further aspects and advantages of the invention will become apparent from the following description of particular embodiments.

BRIEF DESCRIPTION OF THE DRAWINGS

[0009] Embodiments of the present invention will be described hereinafter, by way of example only, with reference to the accompanying drawings in which like reference signs relate to like elements and in which:

[0010] **FIG. 1** is a schematic representation of an architecture of a multiprocessor system for supporting a web site;

[0011] **FIG. 2** is a schematic representation of a racking system incorporating an example of a carrier in the form of a rack-mountable shelf according to a first example;

[0012] **FIG. 3** is a front view of an example of a carrier in the form of a shelf of **FIG. 2**;

[0013] **FIG. 4** is a rear view of an example of the shelf of **FIG. 2**;

[0014] **FIGS. 5A, 5B** and **5C** are schematic perspective views and a schematic exploded view respectively of an example of an information processing cartridge for mounting in the shelf of **FIG. 2**;

[0015] **FIG. 5D** is a schematic perspective view of an example of an information processing cartridge for mounting in the shelf of **FIG. 2**;

[0016] **FIG. 6** is a schematic perspective view of an example of a combined switch and service processor module for mounting in the shelf of **FIG. 2**;

[0017] **FIG. 7** is a schematic perspective view of an example of a power supply module for mounting in the shelf of **FIG. 2**;

[0018] **FIGS. 8A, 8B** and **8C** are a schematic plan view and schematic perspective views, respectively, of an example of the chassis and midplane of the shelf of **FIG. 2**;

[0019] **FIG. 8D** is a schematic perspective view of a part of a base member of the shelf of **FIG. 2**;

[0020] **FIGS. 9A, 9B** and **9C** are schematic front, top and rear views, respectively, of an example of a midplane of the shelf of **FIG. 2**;

[0021] **FIG. 10** is a schematic cross section view through the shelf of **FIG. 2**;

[0022] **FIG. 11** is a functional block diagram of an example of an information processing subsystem for the information processing cartridge of **FIG. 5**;

[0023] FIG. 12 is a functional block diagram of an example of an information processing subsystem for the combined switch and service processor module of FIG. 6;

[0024] FIG. 13 is a functional block diagram of an example of a subsystem for the power supply unit of FIG. 7;

[0025] FIG. 14 is a functional block diagram showing the connectivity between the components of the shelf of FIG. 2;

[0026] FIG. 15 is a functional block diagram showing the external connectivity of the shelf of FIG. 2;

[0027] FIG. 16 is a schematic representation of a shelf showing the external connections from the shelf of FIG. 2;

[0028] FIG. 17 is a schematic representation of a rack mounted system comprising a plurality of such shelves;

[0029] FIG. 18 is a functional block diagram of a further example of an information processing subsystem for the information processing cartridge of FIG. 5;

[0030] FIG. 19 is a functional block diagram of a further example of an information processing subsystem for the information processing cartridge of FIG. 5; and

[0031] FIG. 20 is a functional block diagram of a another example of an information processing subsystem for the information processing cartridge of FIG. 5.

[0032] While the invention is susceptible to various modifications and alternative forms, specific embodiments are shown by way of example in the drawings and are herein described in detail. It should be understood, however, that drawings and detailed description thereto are not intended to limit the invention to the particular form disclosed, but on the contrary, the invention is to cover all modifications, equivalents and alternatives falling within the spirit and scope of the present invention as defined by the appended claims.

DESCRIPTION OF PARTICULAR EMBODIMENTS

[0033] Embodiments and examples are described hereafter by way of example only in the following with reference to the accompanying drawings.

[0034] Shown in FIG. 1 is an example of an application of a high capacity multiserver system 1 for implementing a network-connected web site such as, for example, an airline reservation system on the World Wide Web.

[0035] As shown in FIG. 1, an external network 3 (e.g., the Internet) for communicating with a user 5 can be connected to gateways 7 which can be connected to an entry edge server group 9 implemented by a web farm. The entry edge server group 9 forms an interface to the external network 3. The entry edge server group 9 can then be connected by switches 11 and a firewall 13 to a web edge server group 15 that can also be implemented as a web farm as shown in FIG. 1. The web edge server group 15 can serve to cache web pages that are readily accessible to users 5 accessing the system 1 from the external network 3, for example for checking flight times, etc. The web edge server group can comprise a number of blade server (BS) shelves and a number of network addressable storage (NAS) shelves for storing critical data. The web edge server group 15 can

be further connected by a further firewall 17 to a plurality of application servers 19, which can be responsible for, for example, processing flight reservations. The application servers 19 can then be connected via a further firewall 21 to computer systems 23, 25, for example, e-commerce services including financial services for receiving and processing payment for airline reservations.

[0036] As will be appreciated, the server system described above with reference to FIG. 1 is only an example of a possible application for a multiprocessor server system. Multiprocessor server systems have many different applications and the present system is not limited to being applicable for use in only one or a limited number of such applications, rather multiprocessor server systems as described herein are operable for use in many different applications. A non-exhaustive list of such alternative applications includes: e-commerce web server systems; telecommunications network server systems; LAN application and file server systems and remote vehicle control systems.

[0037] With reference to FIG. 2, there is shown a schematic perspective representation of a rack system 31 as viewed from the front including left and right front uprights 32 and 33 and left and right rear uprights 34 and 35. The uprights can be formed with apertures for receiving shelf fixings (e.g., screws, bolts, clips, etc., for mounting brackets, slides, rails, etc.).

[0038] Also shown in FIG. 2 is an example of a blade server shelf 41 mounted in the rack system 31. The shelf 41 forms a carrier configured to carry a plurality of information processing cartridges 43 located side by side along the shelf.

[0039] The term "shelf" is used herein in a conventional way to describe a structure that is mountable in rack system 31 and is configured to carry one or more components to form at least a part of a rack-mountable system. In the present example, the shelf 41 is three-dimensional, having a height (H), width (W) and depth (D). In the present example, one dimension (hereinafter described as the height, H) is smaller than the other dimensions (hereinafter described as the depth, D, and the width, W) to facilitate mounting of the shelf within the rack system 31. It will be appreciated that although the width and depth are typically constrained by the dimensions of the racking system for which the shelf is designed, there is more freedom as regard the height, subject to taking account of any appropriate standards and packaging considerations.

[0040] Each of the information processing cartridges contains at least one processor. Each information processing cartridge in the present example is operable as a server. In the described examples, the information processing cartridges are configured as robust enclosed modules.

[0041] In the example to be described in more detail presently, the information processing cartridges, when aligned in the carrier shelf, look like rectangular slabs, or blades. Accordingly, an information processing cartridge can be described as a blade. The information processing cartridges 43 comprise information processing modules enclosed in an enclosure, or housing, so that the information processing modules have the form of cartridges. Also, as the information processing cartridges are to operate as computer servers in the example described in more detail presently, an information processing cartridge 43 can also be described as

a server blade. Accordingly, in the context of this example, the terms module, cartridge and blade are used interchangeably.

[0042] The illustrated example of a shelf 41 is configured to carry sixteen information processing cartridges 43, each of which is removably mountable in a respective opening 45 in the front of the shelf, whereby the information processing cartridges can be inserted into and removed from the front of the shelf 41 without removing the shelf 41 from the rack system 31.

[0043] In the present example, the shelf 41 comprises a three-dimensional, generally rectangular, enclosure, or housing, 47 that is suitable for mounting in generic racking systems including both 4-post and 2-post systems. It can be mounted on fixed rigid rack mounting ears and/or a simple slide/support system. The present example is designed for standard 19"-wide racking (1"=25.4 mm) as defined, for example, in the well-known IEC297 and EIA 310 specification standards with height corresponding to the so-called 3U (3 standard unit) height. For mounting such a 3U unit in such a 19"-wide racking system, with a depth of, say 25" or 30", the enclosure can be arranged with a height of up to about 130.5 mm, a width of up to about 445 mm and a depth, including all hardware and fascias, but excluding cable management, of up to about 635 mm, with the depth from the front-most point of a fascia to a rear I/O connector panel of a rear mounted Field Replaceable Unit (FRU) of about 610 mm. Of course, other examples designed for other racking systems could have different dimensions.

[0044] This example of a shelf 41 has a single enclosure, or housing, 47 that houses a number of modular units or subsystems, the majority of which are replaceable in the field and are therefore known as Field Replaceable Units (FRUs). These modular units include the information processing cartridges 43.

[0045] The shelf enclosure 47 can be fabricated from sheet material (e.g., from steel sheet) to form a chassis portion 49 that includes a base 51, two sides 53 and 55, a front 57 and a rear 59. The word "front" as used here is merely used as a label herein to refer to the face, or wall 57 of the enclosure that is located at the main access side of the rack system 31 in use when the shelf is mounted therein. Similarly, the words "rear" and "side" are merely used as labels herein to refer to the faces, or walls 59, 53 and 55 that, in use, are located at those respective positions when the shelf is mounted in the rack system 31.

[0046] The openings 45 can be formed in the front face 57 for receiving the information processing cartridges 43 and, as will be explained later, apertures can also be formed in the rear face 59 for receiving further FRUs. The enclosure can further include a removable top cover 61 that can be secured to the chassis portion 49 by suitable fastening (e.g., screws). The apertures in the front and rear faces 57 and 59 allow at least some of the FRUs to be inserted into and/or removed from the shelf enclosure 47 via the front or the rear thereof, as appropriate, without removing the shelf from the racking. Access to components mounted in the shelf that are not accessible via one of the apertures in the front 47 and rear 59 faces can be achieved by removing the shelf enclosure 47 from the racking system 31 and then removing the top cover 61 of the shelf enclosure 47.

[0047] FIG. 3 is a front view of an example of a shelf 41 for a first example. A plastic front bezel 63 can be provided

that fits on the front face 57 (shown in FIG. 2) of the chassis 49 of the shelf enclosure 47. The front bezel 63 can be formed as a unitary removable part that spans the whole width and height of the front of the shelf enclosure 47. The front bezel 63 could alternatively include a number of separate components, or mouldings. The front bezel can include a peripheral portion 64 that can provide areas for corporate and product branding marks, for identification and numbering for the information processing cartridge and for a bar code label (all not shown). One or more apertures 65 can be formed in the peripheral portion 64 of the bezel 63. The apertures 65 in the bezel can be arranged to align with one or more apertures (e.g. a slot (not shown in FIG. 3) in the front face of the chassis. In use, air can pass through the apertures 65 to flow into the shelf enclosure 47 to reach FRUs that are mounted in the shelf enclosure 47 through the rear face 59 thereof. Air flowing through the aperture 65 flows into a plenum chamber 66 (not shown in FIG. 3) to flow past the processing cartridges 43 to reach rear mounted FRUs. A central area 67 of the front bezel 63 can be open allowing access to the openings 45 in the front face 57 of the shelf enclosure 47 for insertion and removal of the information processing cartridges 43. Where no active module is mounted in a location for an information processing module, a blanking panel, or filler panel, such as the blanking panel 44, can be located in that location. LED indicators 69 can be mounted on a system indicator printed circuit board (not shown) behind a designated area of the bezel to provide an indication of system status via light guides incorporated into the bezel. A further system indicator board (also not shown) carrying LED indicators can be provided inside the shelf enclosure to be visible from the rear thereof.

[0048] As mentioned above, in the present example of a shelf, up to sixteen information processing cartridges 43 can be installed in respective openings 45 in the front face 57 thereof. The number of information processing cartridges 43 actually installed in any installation is dependent upon the system configuration required. Various features relating to the information processing cartridges 43 that are shown in FIG. 3 will be described later.

[0049] FIG. 4 illustrates the rear of the shelf unit of FIGS. 2 and 3. This shows two different types of FRU 71 and 81 (4 units in total) that have been inserted into respective apertures 72 and 82 in the rear of the shelf enclosure 47. The FRUs shown in FIG. 4 include two Combined Switch and Service Processors (CSSPs) 71 and two Power Supply Units (PSUs) 81. Various features shown in FIG. 4 will be described later.

[0050] Before proceeding with a more detailed description of each of the FRUs 43, 71 and 81 introduced so far and of the construction of the shelf 41, there follows a brief description of an information processing cartridge 43, a CSSP 71 and a PSU 81 with reference to FIGS. 3, 4, 5, 6 and 7.

[0051] FIG. 5A provides a perspective view, partly from the rear, of an information processing cartridge 43. FIG. 5B provides a perspective view, partly from the front of the same information processing cartridge 43. FIG. 5C provides an exploded perspective view of the construction of the information processing cartridge 43. Here it is to be noted that the term "rear" is applied in the context of the position, when installed, of the information processing cartridge, with

respect to the shelf **41** (i.e. in this case the “rear” of the information processing cartridge **43** is the innermost part of the information processing cartridge when it is inserted in the shelf **41**). Likewise, “front” refers in the present context to the outermost part of the information processing cartridge when it is inserted in the shelf **41**.

[0052] With reference to **FIGS. 3, 5A and 5B**, it will be noted that information processing cartridges are three-dimensional, having a height (h), width (w) and depth (d). If, as in the present example, the information processing cartridges are to be arranged in a one-dimensional array (a row) across the shelf, then efficient packing for the information processing cartridges is achieved where one dimension (here the width, w) is smaller than the other dimensions (here the depth, d, and the height, h). In a particular example, the enclosure of a processing cartridge **43** has a height h, width w and depth d of 115 mm, 26 mm and 315 mm, respectively, although of course, other examples may have different dimensions.

[0053] It will be noted that an enclosure **101** of the present example of an information processing cartridge **43** has six, generally rectangular, faces. For convenience only, the face that is visible from the front of the racking when an information processing cartridge **43** is mounted in the shelf **41** is known as the front face **102**. The opposite face is known as the rear face **103**. In the present example these two faces, as well as top and bottom faces **104** and **105**, and the side faces **106** and **107** have the shape of elongate rectangles.

[0054] Although in the present example the information processing cartridges have six generally rectangular faces, it will be appreciated that other examples could have other configurations. For example, rather than having a generally rectangular shape, the side faces of another example of an information processing cartridge could have the general shape of a triangle (whereby the information processing cartridge may then only have five faces), a pentagon (whereby the information processing cartridge may then have seven faces), and so on. Indeed, one or more or all of the edges could be curved. However, it will be appreciated that the present configuration provides advantages for example, in terms of manufacturing, engineering and packing density within a shelf **41**.

[0055] In this example, the information processing cartridge enclosure **101** is fabricated from two housing portions. The first housing portion **109** can be fabricated from, for example, a metal (e.g., pressed steel) and can include one side face **106**, the rear face **103** and part of the top face **104**. The part of the top face formed by the metal portion **109** is given the reference **1041** in **FIG. 5A**. The second housing portion **110** can be fabricated from, for example, a plastics material and can include the other side face **107** and the front faces **102** and bottom face **105** and the remaining part **1042** of the top face **104**. In the present example, a plastics material used is PolyCarbonate Acrylonitrile Butadiene Styrene (PCABS), however many other plastics materials such as other ABSs and nylons may be used. The metal portion **109** also includes a part **1021** corresponding to the front face **102** and a part **1051** corresponding to a part of the bottom face **105**. The parts are covered by the plastics portion **110** when enclosure **101** is fully assembled. These parts are

visible in the exploded view of **FIG. 5C**. The two housing portions **109** and **110** are secured to one another by fixings such as screws **118**.

[0056] As shown in **FIG. 5A**, a groove **108** runs along the length of the plastic top face portion **1042**. This groove **108** is provided for interfacing with a guide member of the shelf chassis (not shown in **FIG. 5A**, but see **FIGS. 8B and 8C**). A similar groove **113** is formed in the bottom face **105** of the plastics portion **110** as shown in **FIGS. 5B and 5C**. This groove **113** is provided for interfacing with a guide member of the shelf chassis (not shown in **FIGS. 5B and 5C**, but see **FIG. 8D**).

[0057] The provision of the enclosure **101** means that the information processing cartridge **43** can safely be handled by an operator who is not a skilled technician. Also, through the use of the enclosure **101**, the information processing cartridge is a robust unit that protects its inner workings from the outside environment and vice versa. The use of a conductive enclosure, e.g., a metal enclosure, can result in the information processing cartridge including its own electromagnetic shielding. To this end, the enclosure **101** can also be provided with an internal electromagnetic interference (EMI) shielding member **116** as shown in **FIG. 5C**. The EMI shielding member can be located between the internal components **112** of the information processing cartridge **43** (not described in detail with reference to **FIGS. 5A to 5C**, but see **FIGS. 11 and 18** below) and the plastics portion **110**. The EMI shielding member can be secured to the plastics portion **110**, for example by heat bonding or an adhesive. In other examples, the plastics portion could have a conductive layer deposited thereon, or conductive plastics material could be used. In this example, the EMI shielding member **116** is provided with electromagnetic interference (EMI) fingers **114** to ensure good contact with the shelf chassis and the adjacent components. These fingers **114** extend through EMI finger apertures **1141** in the plastics portion **110**.

[0058] As shown in **FIGS. 3, 5B and 5C**, the information processing cartridge **43** incorporates an injector/ejector handle **111** on the front face **102** for facilitating insertion and latching of the information processing cartridge **43** within an aperture in the shelf **41**.

[0059] As shown in those Figures, the handle **111** of the injector/ejector lever extends substantially the whole height of the front face of the information processing cartridge **43**, thereby increasing the mechanical advantage and facilitating injection and ejection of the information processing cartridge **43**. As is further shown in those Figures, the front face **102** of the information processing cartridge **43** has perforations **115**, in the present example slits, to allow for airflow into the information processing cartridge **43**. The front face part **1021** of the metal portion **109** has perforations corresponding to those in the front face **102** such that airflow into the information processing cartridge **43** is not impeded. It will be noted in **FIGS. 3, 5B and 5C** that the handle **111** is narrower in its middle than at its ends. This reduces any masking effect of the handle **111** on the airflow to the perforations **115** in the front face of the information processing cartridge **43** and facilitates grasping of handle **111**. The handle **111** can be bowed out from the front face of the information processing cartridge to further facilitate grasping thereof and to reduce any masking effect with regard to

the perforations. In other examples, the handle 111 could have an open frame-like structure to further facilitate air-flow.

[0060] As shown in FIG. 5A, the rear face 103 of the information processing cartridge 43 also has perforations 117 to allow for air to be exhausted from the rear of the information processing cartridge 43. A fan can be located within the enclosure 101 of an information processing cartridge 43. In the present example the fan is a combined radial fan (blower) and heat sink to direct cooling air onto a processor of the information processing cartridge, which fan also encourages air movement within the enclosure 101. LED indicators 119 (see FIGS. 3 and 5B) can be provided on the front face 102 of an information processing cartridge to indicate whether power is on, whether service intervention is required and whether the information processing cartridge 43 can be removed. A connector 120, for example a 40 way single connector attachment (SCA-2) connector (a small computer systems interface (SCSI) connector), can be provided at the rear of the information processing cartridge 43 for electrical connection of the information processing cartridge 43 within the shelf 41. The connector 120 is advantageously able to withstand repeated removals and insertions of the enclosure 101 from and into a shelf 41. The connector arrangement can include a guide pin arrangement to prevent module misalignment during insertion of the information processing cartridge into the receiving location.

[0061] Thus an example of features and the construction of an information processing cartridge enclosure has been described. Although particular materials and constructions have been described, it will be appreciated that other examples could be employed. Indeed, it will be appreciated that this particular example relates to only a possible form for the processing cartridge 43. An example of an alternative construction will now be described with reference to FIG. 5D.

[0062] FIG. 5D provides a perspective view, partly from the rear, of an alternative information processing cartridge 43. Here it is to be noted that the term "rear" is applied in the context of the position, when installed, of the information processing cartridge, with respect to the shelf 41 (i.e. in this case the "rear" of the information processing cartridge 43 is the innermost part of the information processing cartridge when it is inserted in the shelf 41).

[0063] In this example, the information processing cartridge enclosure 101 is fabricated from pressed steel to form two chassis portions. The first portion 234 includes one side face 107, and part of each of the front and rear faces 102 and 103 and the top and bottom faces 104 and 105. The second portion 235 includes the other side face 108 and the remaining part of each of the front and rear faces 102 and 103 and the top and bottom faces 104 and 105. The two chassis portions 234 and 235 meet at a groove 236 and are secured to one another by fixings (e.g., one or more screws, not shown). Grooves 236 run along the top and bottom faces 104 and 105 of the enclosure 101 and are provided for interfacing with guide rails of the shelf chassis 49 (not shown in FIG. 5, but see FIG. 8C). A cover portion that is secured to the chassis portion forms the other side face 106. It will be appreciated however, that in another example, the chassis portions could be joined at a position other than the groove 108, with the groove 108 being formed entirely in one of the

chassis portions. Alternatively, the enclosure 101 may be constructed from a number of sheets of steel, with each sheet forming one of the faces.

[0064] FIG. 6 provides a perspective view, partly from the front, of a Combined Switch and Service Processor (CSSP) cartridge (or CSSP) 71. Here it is to be noted that the term "front" is applied in the context of the position, when installed, of the CSSP cartridge 71, with respect to the shelf 41 (i.e. in this case the "front" of the CSSP cartridge 71 is the innermost part of the CSSP cartridge 71 when it is inserted in the shelf 41).

[0065] With reference to FIGS. 4 and 6, it will be noted that a CSSP cartridge 71 is three-dimensional, having a height (h), width (w) and depth (d). In a particular example, the enclosure of a CSSP 71 has a height h, width w and depth d of 43 mm, 202 mm and 278 mm, respectively, although of course, other examples may have different dimensions.

[0066] An enclosure 121 of present example of a CSSP cartridge 71 has six, generally rectangular, faces. For convenience only, the face that is visible from the rear of the racking when a CSSP cartridge 71 is mounted in the shelf 41 is known as the rear face 122. The opposite face is known as the front face 123. In the present example these two faces, as well as side faces 126 and 127 have the shape of elongate rectangles. The top and bottom faces 124 and 125 are also rectangular, but not elongate in the manner of the front, rear, top and bottom faces. Although in the present example the CSSP cartridges have six generally rectangular faces, as for the information processing cartridges 43 it will be appreciated that other examples could have other configurations.

[0067] In this example, the CSSP enclosure 121 is fabricated from steel sheet to form a chassis portion that includes the bottom face 125, the front and rear faces 122 and 123 and the side faces 126 and 127. A cover portion that is secured to the chassis portion forms the other top face 124. The cover portion is secured to the chassis portion by suitable fixings, for example one or more screws 128. It will be appreciated however, that in another example, other faces, or portions, of the enclosure could form the chassis and the cover portions. The provision of the enclosure 121 means that the CSSP cartridge 71 can safely be handled by an operator who is not a skilled technician. Also, through the use of the enclosure 121, the switch cartridge is a robust unit that protects its inner workings from the outside environment and vice versa. The use of a conductive enclosure, e.g., a metal enclosure, means that the CSSP cartridge includes its own electromagnetic shielding. To this end the CSSP enclosure 121 is provided with EMI fingers 129 to ensure good contact with the shelf chassis and the adjacent components.

[0068] As shown in FIG. 4, the CSSP cartridge 71 incorporates two D-shaped handles 132 to facilitate insertion and removal of the CSSP cartridge 71 with respect to an aperture 72 in the rear face of the shelf enclosure. A latch member 131 can be pivotably mounted on a plate that can be secured (e.g., using screws) to the rear face of the shelf enclosure. The latch member 131 is configured to engage one of the handles 132 and to secure the CSSP cartridge 71 in place. In other examples, the CSSP cartridge 71 could be provided with an injector/ejector handle in a manner similar to the information processing cartridge. As shown in FIG. 6, the front face 123 of the CSSP cartridge 71 has perforations 133 to allow for airflow into the CSSP cartridge 71. As shown in

FIG. 4, the rear face **122** of the CSSP cartridge **71** has perforations **135** to allow for air to be exhausted from the rear of the CSSP cartridge **71**.

[0069] At least one fan can be located, for example behind the perforated portion **135** of the rear face, in a CSSP cartridge **71** to channel cooling air through the CSSP cartridge **71** from the front to the rear. In this particular example shown, two fans are provided, one behind each set of perforations **135**. LED indicators **137**, as shown in **FIG. 4**, can be provided on the rear face **122** of the CSSP enclosure **121** to indicate whether power is on, whether service intervention is required and whether the switch can be removed. Additional link status indicators can be provided integral to 2×4 stacked RJ-45 connectors **139**, also shown in **FIG. 4**. As shown in **FIG. 4**, electrical connections **141** can be provided at the front face of the CSSP (i.e. on the face that in use is inside the shelf enclosure **47**). Suitable connections for use in the present example include a connector for power connections, a connector for serial management data connections and a connector for information connections. In the present example, information connections are implemented using an Ethernet information communication protocol, e.g. at 1 Gigabit (Gb). However other protocols could equally be used, for example the Infiniband information communication protocol. The connector arrangement can include a guide pin arrangement to prevent module misalignment during insertion of the CSSP module into the receiving location. For this purpose, guide pin holes **142** can be provided on the front face **123** into which guide pins may pass to aid module alignment.

[0070] In the present example, up to two CSSPs **71** can be mounted at any one time at the rear of the shelf unit in corresponding apertures **72** in the rear face of the shelf enclosure **47**. The number of CSSPs **71** provided in any particular implementation depends upon system configuration and the need, or otherwise, for redundancy.

[0071] It will be appreciated that one possible construction of the CSSP cartridge **71** has been described and that as for the information processing cartridge **43**, other examples could employ other materials and/or constructions.

[0072] **FIG. 7** provides a perspective view, partly from the front, of a power supply unit (PSU) cartridge **81**. Here is it to be noted that the term “front” is applied in the context of the position, when installed, of the PSU cartridge **81**, with respect to the shelf **41** (i.e. in this case the “front” of the PSU cartridge **81** is the innermost part of the PSU cartridge **81** when it is inserted in the shelf **41**).

[0073] With reference to **FIGS. 4 and 7**, it will be noted that PSU cartridge **81** is three-dimensional, having a height (h), width (w) and depth (d). In this particular example, the order to provide for a dense packing of the FRUs in the rear of the shelf **41**, the PSU cartridge **81** has two dimensions (hereinafter described as the width, w, and the depth, d) that are generally similar. In a particular example, the enclosure of a PSU cartridge **81** has a height h, width w and depth d of 83 mm, 202 mm and 276 mm, respectively, although of course, other examples may have different dimensions.

[0074] An enclosure **145** of present example of a PSU cartridge **81** is of generally oblong shape, but has the “top” “front” edge cut away to form an additional “top” “front” sloping face. The enclosure **145** therefore has five,

generally rectangular, faces and two faces of generally rectangular shape with one corner cut away. For convenience only, the face that is visible from the rear of the racking when the PSU cartridge **81** is mounted in the shelf **41** is known as the rear face **146**. The opposite face is known as the front face **147**. In the present example these two faces and the two side faces **150, 151** are of elongate, generally rectangular shape with one corner cut away, given that the width and depth of the PSU cartridge are similar, whereas the top and bottom faces **148, 149**, although still rectangular, are not, in this example, notably elongate. A top front face **148a** is present at the top front of the enclosure. Thus the front of the enclosure is sloped at the top edge. As for the information processing cartridges **43**, however, it will be appreciated that other examples could have other configurations.

[0075] In this example, the PSU cartridge enclosure **145** is fabricated from steel sheet to form a housing portion that includes the bottom face **149**, the side faces **150 and 151** and the front and rear faces **146 and 147**. Cover portions that are secured to the housing portion form the top face **148** and top front face **148a**. The cover portions are secured to the chassis portion by suitable fixings, for example one or more screws **152**. It will be appreciated however, that in another example, other faces, or portions, of the enclosure could form the chassis and the cover portions. The provision of the enclosure **145** means that the PSU cartridge **81** can safely be handled by an operator who is not a skilled technician. Also, through the use of the enclosure **145**, the PSU cartridge **81** is a robust unit that protects its inner workings from the outside environment and vice versa. The use of a conductive enclosure, e.g., a metal enclosure, means that the PSU cartridge includes its own electromagnetic shielding. To this end the PSU enclosure **145** is provided with EMI fingers **153** to ensure good contact with the shelf chassis and the adjacent components.

[0076] As shown in **FIG. 4**, the PSU cartridge **81** incorporates two D-shaped handles **156** to facilitate insertion and removal of the PSU cartridge **81** with respect to an aperture **82** in the rear face of the shelf enclosure. A latch member **155** can be pivotably mounted on a plate that can be secured (e.g., using screws) to the rear face of the shelf enclosure. The latch member **155** is configured to engage one of the handles **156** and to secure the PSU **81** in place. In other examples, the PSU **81** could be provided with an injector/ejector handle in a manner similar to the information processing cartridge. As shown in **FIG. 7**, the front face **147** of the PSU cartridge **81** has perforations **157** to allow for airflow into the PSU cartridge **81**. As shown in **FIG. 4**, the rear face **146** of the PSU cartridge **81** also has perforations **159** to allow for air to be exhausted from the rear of the PSU cartridge **81**.

[0077] A pair of fans can be located behind the perforated portions **159** of the rear face of a PSU cartridge **81** to channel cooling air through the PSU cartridge from the front to the rear. LED indicators **161** can be provided on the rear face **146** of the PSU enclosure **81** to indicate whether input power is good, whether output power is good, whether service intervention is required and whether the PSU can be removed. Electrical connectors **163** can be provided at the front face of the PSU (i.e. on the face that in use is inside the shelf enclosure **47**) for connection to the shelf. The PSU **81** of the present example may suitably employ an SSI-MPS

(Server Systems Interface-Midrange Power Supply) compliant right angle connector at the front face 147 of the PSU 81 to connect to the shelf 41. The power inlet 83 for each PSU 81 can incorporate a cable/connector retention mechanism (not shown) on the rear face 146 of the PSU to prevent accidental or malicious removal of the power input cord from the PSU 81.

[0078] In the present example, the shelf unit enclosure provides slots at the rear of the shelf unit for two hot-swappable, AC input PSUs 81. To provide redundant power supply, both PSU slots are populated. More generally, N+M power supplies can be provided, where N is the minimum number of power supply units needed to support the components mounted in the shelf, and M is a selectable number of 0, 1 or more power supplies to provide for redundancy. In the present example, N=M=1.

[0079] It will be appreciated that one possible construction of the CSSP cartridge 71 has been described and that as for the information processing cartridge 43, other examples could employ other materials and/or constructions.

[0080] If the full complement of information processing cartridges or switches are not fitted to the enclosure, then blanking panels/modules (e.g., the blanking panels 44 shown in FIG. 3) are fitted to all unpopulated positions to maintain the correct airflow and thermal characteristics of the shelf, a safe internal operating temperature for the shelf life expectancy of all shelf components, electromagnetic compliance (EMC) containment and electrostatic discharge (ESD) containment.

[0081] It will be noted that each of the FRUs, such as the information processing cartridges 43, is advantageously contained in its own robust enclosure to facilitate EMC containment, ESD containment, handling, storage and transportation. Each FRU can be configured as a 'sealed' unit in the sense that it can be configured not to have field or customer serviceable parts internally. The FRUs can be configured readily to plug into the shelf enclosure and to be hot swappable. The FRUs can be keyed to prevent incorrect positioning and insertion into the shelf enclosure and are arranged positively to be retained in the shelf by a latching/locking mechanism.

[0082] The examples of FRUs described above are not provided with removable media. In the present example, internal data storage is provided by 2.5" IDE 9.5 mm or 12.7 mm profile hard disk drive (HDD) devices mounted internally in each information processing cartridge 43 and in the CSSP cartridge 71. The drives are not considered as FRUs and are not hot-swappable disk drives in the present example, although they could be in other examples. In other examples, the information processing cartridges can be configured without internal hard disk drives.

[0083] The internal configuration of the shelf 41 and a midplane 171 contained therein is described in the following with reference to FIGS. 8A, 8B8C and 8D, and FIGS. 9A, 9B and 9C.

[0084] FIG. 8A is a schematic plan view showing the internal configuration of an example of a shelf 41 with the cover 61 removed. FIG. 8B is a schematic perspective view from above the rear of the chassis portion 47 of the shelf enclosure with the field replaceable units removed. FIG. 8C is a schematic perspective view from below the front of the

chassis portion 47 of the shelf enclosure with the field replaceable units and the base 51 removed. FIG. 8D is a schematic perspective view from the front and above a part of the base 51 of the shelf 41. FIGS. 9A, 9B and 9C are, respectively, front, top and rear views of the midplane 171. In this example, the midplane is, in use, mounted vertically within the shelf 41 extending across the width W of the shelf 41 at a position approximately half way between the front and the rear of the shelf 41.

[0085] The vertically mounted midplane 171 extends, in this example, across the shelf 41 and allows for the electrical interconnection of the FRUs. The various apertures in the front and rear faces 57 and 59 of the shelf 41, in combination with the midplane 171, can be provided with guides (e.g., rails 181) and keying e.g., offset connector positioning for the insertion of the FRUs into the enclosure and midplane 171. The midplane 171 can be a double-sided, or multi-layer printed circuit board (PCB) assembly that can be mounted vertically in a rigid manner within the enclosure. It can carry connectors 175 on a front surface 172 for making electrical connection with corresponding connectors 120 on the information processing cartridges 43. It can also carry connectors 177 and 179 on rear surface 173 for making electrical connection with corresponding connectors 141 and 163 on the CSSPs 71 and the PSUs 81, respectively. Conductive tracks (not shown) on and through the midplane 171 can be provided to interconnect the various connectors. In addition, the midplane can provide connectors for receiving corresponding connectors connected to first and second indicator boards 183 and 184 that each carry a respective set of LED indicators 69. In the present example, the midplane 171 is not configured as a FRU and is not hot swappable. It is perforated to facilitate airflow through the shelf 41. The midplane 171 can include openings 185, which cooperate with openings in the enclosures of the FRUs 43 and 81, to provide a path for cooling air to pass from the front to the rear of the shelf 41, the cooling air being driven by fans in one or more of the FRUs, for example in the PSUs 81, possibly also in the information processing cartridges 43.

[0086] A plenum chamber floor member 94 can extend horizontally from the front of the midplane 171 to the front face 57 of the shelf enclosure, or chassis 47. The member 94 provides a floor for a plenum chamber 66, which is supplied with air via the apertures 65 in the front bezel and, in the illustrated example, the slot shaped aperture 68 in the front face 57 of the shelf enclosure 47. Although, for reasons of ease of illustration a slot shaped aperture 68 is shown, a plurality of apertures 68 aligned with the blade receiving locations may be provided. The aperture or apertures 68 can serve both as air vents for a flow of air to the plenum chamber 66, and also as latching locations for latching portions at the top of the injector/ejector levers 111 for the blades shown in FIGS. 5B and 5C. The top and sides of the plenum chamber are provided by the top cover 61 and side faces 53 and 54 of the shelf enclosure 47.

[0087] A plurality of cartridge guides 97 can be provided at the underside of the plenum chamber floor member 94. In the present example, these guides comprise sprung wire members, e.g., of a resilient metal such as spring steel, that are attached to the top surface of the plenum chamber floor member 94 and extend through a plurality of apertures therethrough to result in a row of guides 97 at the underside of the plenum chamber floor member 94. This arrangement

is shown in FIGS. 8B and 8C. In FIG. 8B, the sprung wire members 98 are shown attached to the top surface of the plenum chamber floor member 94. In the present example, the sprung wire members 98 are arranged in pairs, such that two guides 97 are provided by each spring clip 98. In FIG. 8C, the guides 97 formed by the protruding portions of the sprung wire members 98 are shown at the underside of the plenum chamber floor member 94. Each guide 97 is advantageously positioned so as to interface with the groove 108 in the plastics material in the upper face 104 of a processing cartridge 43 as shown in FIGS. 5A-5C to aid correct alignment and to facilitate insertion of the processing cartridge during insertion of the cartridge into the shelf 41. The use of the spring clip as a guide 97 also serves to urge the processing cartridge downwards to provide a secure mounting of the processing cartridge 43, to take account of manufacturing and operational tolerances and to assist in insertion of the processing cartridge where an operator does not align this absolutely correctly.

[0088] A further row of cartridge guides 99 can be provided at the upper surface of the base 51 of the shelf 41. In the present example, as shown in FIG. 8D, these guides 99 have a rail like form, which can be achieved by punching or stamping through the base 51 of the shelf 41. In this example each guide, or rail, 99 includes a pair of upstands separated by an aperture 100 through the base 51. The size of the aperture 100 can correspond to the width between the upstands. The separation of the upstands is selected so that the overall width of the resulting rails is slightly less than the width of a groove formed in the lower face of an information processing cartridge 43. Thus, each guide 97 is advantageously arranged so as to interface with the groove 1113 in the plastics material in the lower face 104 of a processing cartridge 43 as shown in FIGS. 5A-5C to aid correct alignment and to facilitate insertion of the processing cartridge during insertion of the cartridge into the shelf 41.

[0089] In the present example, where the guides 97 and 99 are formed from metal, the provision of the grooves 108 and 113 in plastics material at the upper and lower faces, respectively, of each information processing cartridge 43 (see FIGS. 5A-5B) results in a combination of metal and plastics materials that can provide a low friction interaction, facilitating insertion of the information processing cartridges.

[0090] If, for example, the information processing cartridge enclosure is made of a metal, it may be undesirable to provide metal guides to avoid a metal to metal interaction. In such a case, for example, it may be desirable to form the guides from a plastics material having a low coefficient of friction, such as polytetrafluoroethene (PTFE) or polythene. Plastics rails could be attached to the underside of the plenum chamber floor member 94 and/or on the upper surface of the base 51 of the shelf 41. In such an example, grooves on the upper and lower faces of the information processing cartridges 43 could then be formed of metal or plastics and still result in a low friction arrangement.

[0091] A CSSP/PSU divider 96 can be provided to the rear of the midplane 171 and can extend horizontally to the rear face 59 of the shelf enclosure 47. The CSSPs 71, when inserted, are supported by the divider 96. To aid the correct insertion of the CSSPs 71, CSSP guide pins 178 are provided on the midplane 171 at positions adjacent connectors 177 on the midplane 171 for connection to the CSSPs 71.

[0092] Respective positions 88 and 89 can be formed in the front face 57 and the rear face 59 at which first and second indicator boards 183 and 184 supporting the indicator LEDs 69 can be located. These positions 88, 89 therefore include an aperture through the respective face of the shelf enclosure 47 such that indicator LEDs 69 mounted onto a circuit board attached to the inside of the shelf enclosure 47 may be viewed from outside the shelf enclosure.

[0093] There now follows a more detailed description of the midplane 171.

[0094] As mentioned above, the midplane 171 connects all the elements of a shelf together, including, in the present example, up to sixteen information processing cartridges 43, up to two CSSPs 71, two PSUs 81 and the two indicator boards 183 and 184. In the present example, due to its location within the shelf enclosure, the midplane 171 is not configured to be swappable. Accordingly, to maximize the system reliability, the midplane is configured to provide as a high level of reliability as possible. To this end, the midplane is advantageously configured without active devices and to include the minimum number of decoupling capacitors consistent with good design practice (ideally zero).

[0095] The midplane supports a number of paths for various power and signal lines to interconnect the FRUs.

[0096] In the present example, each information processing cartridge 43 has a high speed information signal connection (e.g., a Gigabit (Gb) Ethernet SERIALizer/DESERIALIZER (SERDES) connection) to each of the CSSPs 71, each connection consisting of two pairs of differential signals. In a conventional manner therefore, the tracking of the paths for these signals is arranged to keep the pairs well balanced and on a single signal layer (i.e. without vias) to support such differential signals at high frequency.

[0097] In addition, in the present example, each information processing cartridge 43 has a serial console connection to the CSSP cartridge 71. Each connection consists of two TTL (Transistor-Transistor Logic) level signals that make a transmit and return (TX and RX) pair.

[0098] Also, each PSU 81 has a management signal connection (e.g., a serial I2C (Inter-IC Bus) connection) to the CSSP cartridge 71 to control power and monitor environmental parameters. The I2C bus comprises of two signals SCL and SDL (serial clock line and serial data line). In addition, an I2C address programming pin is provided for the PSUs 81.

[0099] Each information processing cartridge 43 and PSU 81 can signal to the CSSP cartridge 71 that it is inserted by pulling to ground (GND) a respective Inserted_L signal (i.e., an active low signal). These signals are fed to the CSSP cartridge 71 via the midplane 171.

[0100] Each PSU 81 has five 12 Volt output rails. The routing from each PSU 81 is arranged so that a fault in any single FRU cannot completely interrupt the power to any other.

[0101] As mentioned above, the midplane 171 is provided with appropriate connector arrangements for receiving the connectors on the FRUs.

[0102] In the present example, the information processing cartridge 43 connects to the midplane 171 through a 40 pin

Single Connector Attachment (SCA-2) connector as defined by the Small Computer Systems Interface (SCSI) standard. Accordingly, the midplane carries corresponding connectors **175**.

[**0103**] In the present example, each CSSP cartridge **71** connects to the midplane **171** through a two right-angle **20** pair connector (e.g., 2 mm HM-Zd connectors available from Tyco Electronics). The corresponding connectors **177** on the midplane are straight male parts with a power connector. A guide pin arrangement is provided in addition to the connectors to prevent misaligned modules causing bent pins during insertion. The guide pin also provides a leading ground. The CSSP cartridge **71** also connects to the midplane **171** through a right-angled **125** way 5 row 2 mm connector. The connector **177** on the midplane **171** includes a straight male part. A guide pin arrangement is provided in addition to the connectors to prevent misaligned modules causing bent pins during insertion.

[**0104**] In the present example, as mentioned above, each PSU **81** connects to the midplane **171** through an SSI-MPS specification connector. The contacts are configured 5P/24S/6P with sequenced signal (S) and power (P) pins. Where the connector on the PSU is a 1450230-1R/A male header, solder tails connector, the mating connector **179** on the midplane can be a 1450540-2 vertical receptacle, press-fit connector.

[**0105**] In the present implementation, indicator boards **183** and **184** (see **FIG. 8A**) are provided at the front and rear of the system and are configured as FRUs. In this example they hold three system-level indicator LEDs **69** and include a FRU identity (FRU-ID) programmable read-only memory (PROM) each. Three LEDs **69** are present on the indicator board. There can, for example, be a white locator LED that can be switched by the user for locating the system; a green power-on LED to indicate when the system is powered; and an amber service-required LED to indicate a fault or other condition requiring servicing. These LEDs can be driven by the CSSP **71**.

[**0106**] In the present example, identification information (FRU ID) for the midplane **171** is held on an I2C electrically erasable programmable read only memory (EEPROM) in the front indicator board **183**. In addition to the I2C signals necessary to access the FRU ID EEPROM, the CSSPs **71** provide a current limited supply to the indicator boards **183** and **184** via the midplane. The indicator boards **183** and **184** are also provided with an I2C address programming pin. Depending on the implementation, FRU ID information can be stored instead, or in addition, on the rear indicator board **184**.

[**0107**] As the FRU-ID for the midplane **171** is held on one or both of the indicator boards **183** and **184**, the midplane can be a totally passive unit. The FRU-ID PROMs communicate with the CSSPs **71** via an I2C bus. Each device on the bus has a separate I2C address. The lower three I2C address bits of the EEPROMs used are available as pins on the device, to allow programming with resistors. The least significant bit of this address (**A0**) is passed to the midplane via the corresponding connector. This allows the midplane **171** to program the address of the FRU-ID differently for the front and rear indicator boards **183** and **184**, by pulling the address low for the front board and high for the rear indicator board **183**. This ensures that both EEPROMs are

available on the bus, at different addresses. The FRU-ID for the midplane can be stored on either front or rear EEPROM, but the present example the FRU-ID is stored in the EEPROM on the front indicator board **183**. The EEPROM can be 8 kByte or larger.

[**0108**] As mentioned above, the midplane **171** includes openings **185** to provide a ventilation path for cooling air passing through the shelf **41**. The cooling air passing through the shelf **41** via the midplane **171** can be driven by means of fans provided in each of the information processing cartridges **43** and the power supply modules **81**. The openings **185** shown in **FIGS. 8B, 9A, 9B** and **9C** form schematic representations of openings in the midplane **171**. In practice, the openings could have any form (i.e., a series of large openings, or a number of small perforations), arranged on the midplane to align with corresponding openings or ventilation apertures in the various field replaceable units **43, 71** and **81**. In this way, the path of the airflow from the front of the shelf to the back of the shelf can be configured to be as efficient as possible, depending on the detail configuration of the fan units and the ventilation openings or apertures in the information processing, switch, service processor and power supply unit modules **43, 71** and **81**. Providing the fan units in the field replaceable units **43, 71** and **81**, contributes to the aim of maintaining the chassis **49** and the midplane **171** of the shelf **41** free of active components, thereby minimising cost, and facilitating maintenance. Also, by providing the fan units in each of the field replaceable units, merely inserting and removing field replaceable units automatically adapts the flow of cooling air to the number and type of field replaceable units inserted in the shelf **41**.

[**0109**] As described above, in the present example each of the FRUs is designed to be a non-user serviceable unit. Thus each FRU presents the user with a "sealed" unit which may be inserted into and removed from the shelf **41** as desired or required. If a FRU ceases to be operable, then the user has a choice only of returning the FRU to a supplier or service company for repair or of discarding the non-operable unit. As the FRUs are non-user serviceable, there is no requirement for a skilled technician to be employed in inserting or removing the FRUs into or from a shelf **41**. Thus each FRU is designed such that a non-skilled person should have difficulty in causing damage to the FRU during handling. Moreover, the configuration and construction of the FRUs (e.g., the injector/ejector levers, the grooves in the enclosures of the information processing units, etc), of the shelf enclosure and the midplane (e.g., the guide rails to guide insertion of the FRUs, the locating pins, etc) contribute to facilitating easy insertion and removal of the FRUs.

[**0110**] Shown in **FIG. 10** is an example of the flow of cooling air through the shelf **41** and FRUs **43, 71, 81** mounted therein.

[**0111**] In this example, the cooling air passing through the shelf **41** is drawn generally in a front to rear direction through the shelf **41** by cooling fans mounted within the CSSPs **71** and the PSUs **81**. Two separate flow paths for cooling air are provided in this example. The first, indicated as flow path $\alpha\alpha$ by dotted lines **77** provides cooling air to the CSSPs **71**. The second path, indicated as flow path $\gamma\gamma$ by dotted lines **78** provides cooling air to the information processing cartridges **43** and PSUs **81**.

[0112] The flow of cooling air along path $\alpha\alpha$ enters the shelf 41 through the aperture(s) 65 in the front face 57 of the shelf enclosure 47 into the plenum chamber 66. Further apertures (not shown) could also be provided in the side faces 53 and 55 of the shelf enclosure 47 to allow air to flow into the plenum chamber 66. This air then flows through the plenum chamber 66, and passes over the top edge of the midplane 171 to reach the perforations 133 of the front face of the CSSPs 71. The cooling air then passes through the CSSPs 71, providing cooling to the components thereof before passing out of the CSSPs 71 through the perforations 135 in the rear face of the CSSPs 71 thus being exhausted from the shelf 41. This flow of cooling air along flow path $\alpha\alpha$ is driven by fans 79 mounted within the CSSPs 71. In the present example, a pair of fans 79 is provided within each CSSP 71 and is mounted against the rear face thereof.

[0113] Air flowing along path $\alpha\alpha$ is impeded from flowing around the processing cartridges 43 by plenum chamber floor member 94 and is impeded from flowing to the PSUs 81 by CSSP/PSU divider 96. This flow path $\alpha\alpha$ therefore ensures that air flowing to the CSSPs 71 is not warmed by passage through the processing cartridges 43 and therefore provides maximum efficiency cooling to the CSSPs 71.

[0114] The flow of cooling air along path $\gamma\gamma$ enters the shelf 41 through the perforations 115 in the front face of the information processing cartridges 43. The air thus enters the information processing cartridges 43 and provides cooling to the components thereof. Cooling fans (not shown) within the information processing cartridges 43 direct the cooling air to the processor (CPU) of the information processing cartridge and direct the flow of air in the cartridge thereby increasing cooling efficiency. The air then exits the information processing cartridges 43 through the perforations 117 in the rear face thereof. The air then passes through the apertures 185 through the midplane 171 to reach the PSUs 81. This cooling air then passes through the perforations 157 on the front and upper front faces of the PSUs 81 to enter the PSUs and provide cooling to components thereof. It will be appreciated from FIG. 10 that the sloping rear of the upper face of the PSUs 81 increases the area over which air can be drawn into the PSUs, thereby reducing the back pressure on the air flowing through the shelf unit and aiding the cooling efficiency. The flow of cooling air along path $\gamma\gamma$ is driven by fans 85 mounted within the PSUs 81. In the present example, a pair of fans 85 is provided within each PSU 81 and are mounted against the rear face thereof.

[0115] Air reaching the PSUs 81 via path $\gamma\gamma$ will already have passed through the processing cartridges 43. Such air will therefore be already warmed above the ambient temperature outside of the shelf 41 by its passage through the processing cartridges 43. However, as the cooling requirement of the PSUs 81 is typically less than that for the CSSPs 71, this does not cause any difficulty in the operation of the PSUs 81, which are adequately cooled by this flow of pre-warmed air. The pre-warmed air passing through the apertures 185 through the midplane 171 is impeded from flowing into path $\alpha\alpha$ and entering the CSSPs 71 by the SCCP/PSU divider 96.

[0116] As will be appreciated by the skilled addressee, the arrangement shown in FIG. 10 is illustrative only and other arrangements whereby, for example, a mixture of cool air from the plenum chamber 66 and warmed air from the

processing cartridges 43 is provided to each rear-mounted FRU can readily be constructed.

[0117] With reference to FIG. 11, there now follows a description of functional elements of an information processing cartridge 43 as contained within the information processing cartridge enclosure 101.

[0118] The information processing cartridge 43 includes a microprocessor 192 (a non-limiting example of a microprocessor that can be utilised in the present example is an UltraSPARC™ processor). The microprocessor is mounted on an information processing cartridge motherboard 191.

[0119] A configurable clock generator 193, configured as a programmable clock synthesizer employing a crystal, can be used to produce CPU clock signals, CLKA and CLKB. The clock frequency can be determined by jumper settings (not shown). A vectored interrupt controller (I-Chip) 194 and a configurable core voltage regulator module (VRM) 195 are provided.

[0120] In the present example, memory means for use by the processor 192 when executing instructions can be provided in the form of buffered dynamic random access memory (DRAM), for example configured as dual in line memory modules (DIMMs) 196 with a 72-bit data path with error correction codes (ECC), seated in two sockets on a riser card from the information processing cartridge motherboard 191. The memory capacity can be chosen to suit the processor addressable memory space. For example, in the present example, up to 4 Gigabytes (4 GB) of addressable memory can be provided. Serial Presence Detect (SPD) auto-configuration is provided via a Service Management Bus (SMBus) over an I2C bus 197.

[0121] In the present example, a PCI bus architecture can be employed with a so-called SouthBridge bus bridge 199 with SuperIO and two Gb Ethernet Media Access Control (MAC) devices. As described above, however, other bus protocols (e.g., Infiniband) can be used. A 32 bit PCI bus 198 can be provided from the microprocessor 192. The SouthBridge 199 is a standard form of bus bridge, in the present example packaged in a 352 pin PBGA (Plastic Ball Grid Array) package, that provides the following functions: an SM Bus interface over the I2C bus 197 for access to the SPD (Serial Presence Detect) feature of the DIMMs that allows initialization of the memory controller; an Xbus interface for access via an Xbus 200 (which is a packet switched multiprocessor bus) to a PROM 201, a real time clock (RTC) 202 and an information processing cartridge service controller (hereinafter termed a Blade Service Controller (BSC)) 203; an IDE (Integrated Drive Electronics) interface that provides an ATA-100 (AT Attachment) IDE connection 204 to an IDE disk drive 205; and a serial console interface on a service bus 206 to the BSC 203 that is used for operating system functions including a console function with this embodiment.

[0122] For IO to the midplane 171, two AC-coupled Ethernet interfaces 207 and 208 are provided in the present example, which are packaged in a 316 pin PBGA. These Ethernet interfaces can provide a PCI attached Ethernet MAC capable of operation up to Gigabit Ethernet performance. The physical layer can be implemented using SERIALIZER/DESERIALIZERS (SERDESs) 209 and 210. An example of a SERDES device is the TLK2201 transceiver manufac-

tered by Texas Instruments, Inc. The SERDES devices use differential PECL TX+/- and RX+/- (Positive Emitter Coupled Logic Transmit and Receive) pairs to communicate to the switch portions of the CSSPs 71 over the midplane 171. The RX+/- pairs can be AC coupled at the information processing cartridge 43, the TX+/- pairs can be AC coupled at each CSSP 71. This facilitates hot-swap of the information processing cartridges 43 and the CSSPs 71.

[0123] Asynchronous serial connections 211 and 212 for communication between the BSC 203 and the Service Processor parts of the CSSPs 71 can be provided.

[0124] Internal data storage can be provided in the present example by a hard disk 205 with a capacity of 30 GB or more rated for 24/7 continuous operation. The hard disk 205 is accessed using the primary IDE interface of the SouthBridge 199. The hard disk 205 can hold an operating system, for example a Solaris operating system, and other software and data for performing information processing using the main, or host, processor (CPU) within the information processing cartridge 43.

[0125] In the present implementation, the BSC 203 can be implemented as a microcontroller (e.g., a Hitachi H8 microcontroller). The BSC 203 can provide various functions, including for example: dual access (for the information processing cartridges and the CSSPs 71) to PROM 201 and EEPROM 213 for boot information and a FRU-ID for the information processing cartridge; channelling communication between an information processing cartridge 43 and the service processor part of the CSSPs 71; control of power on reset (POR), system reset and externally initiated reset (XIR) to the microprocessor 192; control of the power, service-required and ready-to-remove LEDs 69; upgrading of field-upgradable firmware, via the serial interface; a watchdog function for the operating system; monitoring the speed of a CPU fan 214; and communications with an EEPROM 215 and the operating system via the Xbus 200.

[0126] In the present example, the BSC 203 can be powered by a 5V service bus (SB) rail as soon as a CSSP 71 and a PSU 81 are fully inserted into the midplane 171, it then turns on other DC/DC converters to provide power to the remainder of the information processing cartridge 43. A BSC reset signal can be derived from a simple conventional power on reset (POR) generator that monitors a 5V supply rail.

[0127] In the present example a 1 MByte Flash PROM 201 can be provided for storing boot variables for Open-Boot™ PROM (OBP) and Power-On-Self-Test (POST). Further OBP variables can be stored in a second 16 kByte (16 kB) I2C PROM 215, accessible via the SouthBridge SM Bus port over the IC Bus 197. The PROM 215 can contain 8 kByte for OBP variables and 8 kByte of unused space. A 16 kByte I2C EEPROM 213 that is accessible via the BSC 203 can contain BSC variables and FRU-ID variables. The EEPROM is nominally divided into 8 kByte for FRU-ID and 8 kByte for the BSC variables. Write protection for the FRU-ID is implemented by BSC firmware. Such write protection may be carried out by, for example, acknowledging instructions to write to the protected area, but not to carry out those write instructions.

[0128] An environmental monitor sensor 215 can be provided to monitor the CPU and ambient temperatures. This sensor can be accessible via the onboard I2C bus from the BSC 203.

[0129] The information processing cartridge 43 can be powered from two, diode commoned, 9V power supply rails 216 and 217. DC/DC converters 218 can be used to provide the voltage levels required by the information processing cartridge 43. The DC/DC converters 218 are supplied by dual 9V inputs 216, 217, individually fused 219, 220 and then diode commoned 221, 222. A 5V DC/DC converter can be turned on as soon as the FRU is fully inserted, with the BSC 203 and required portions of the SouthBridge 199 being powered (the 5VSB rail). A field effect transistor (FET) can be used to gate off the main 5V supply to the rest of the information processing cartridge 43. The DC/DC converter outputs and the main 5V FET can be arranged not to turn on until the BSC 203 turns them on via a signal from the SouthBridge 199. The SouthBridge 199 can be used so that if the BSC 203 is reset (by a watchdog timeout or after a firmware download) the state of the DC/DC converters 218 is not affected. When the remaining outputs from the DC/DC converters 218 are within specification, a PWR_GOOD signal can be asserted low to the BSC 203.

[0130] A SouthBridge resume circuit can be operable to run from 3V3, and a simple Zener diode dropper circuit can be used to generate 3V3 from the 5VSB supply.

[0131] When the FRU is inserted the inrush current can be limited, for example to <1A, and the rate of rise can be configured not to exceed a predetermined value (e.g., 20 A/s) to provide a so-called soft start to facilitate hot-insertion. The intent is to prevent damage to the connectors and to avoid generating noise. A soft start controller 223, which controls a ramping-up of voltage levels, can be enabled when the predetermined signal (Inserted_L signal) is asserted low, this signal is on a short pin in the connector and is connected to ground (GND—not shown) through the midplane 171.

[0132] In the present example, a processor impingement fan (processor fan) 214 is configured to run at full speed to cool the information processing cartridge 43 and the fan. The speed of the processor fan and sink can be monitored by the BSC 203, using a tachometer sense pin on the microcontroller. In the event of the fan speed falling below a predetermined speed, or percentage of its nominal speed (e.g., 80%), the BSC 203 can be arranged to issue an alert. The nominal speed of the fan can be recorded as part of the BSC EEPROM contents.

[0133] The midplane connector 120 for the information processing cartridge 43 is used to establish the connection between the information processing cartridge 43 and the midplane. In the present example it supports up to 84 connections (pins) that will deliver SERDES outputs 224, 225, I2C signals 226, 227, and power 216, 217. Signal connections may be made through a right-angled connector. Power connections may be made through the information processing cartridge right-angled connector. The connector can be configured to facilitate hotswapping of the information processing cartridge, for example by having a low insertion force and/or guide pins to increase the ease of serviceability and prevent module misalignment during insertion.

[0134] Interrupts to the processor 192 can be encoded using an encoded interrupt vector mechanism. An I-Chip Emulator (ICE) 228 functions as an interrupt concentrator, receiving all system interrupts and encoding them as an

interrupt vector according to an interrupt vector code utilisable by the processor 192. In the present example, where an UltraSPARC™ processor is used, the interrupt vector encoding may be based on a 6-bit interrupt vector code.

[0135] With reference to FIG. 12, there now follows a description of an example of a combined switch and service processor (CSSP) 71. In the present example, each CSSP 71 provides the functionality of a Switch 73 and of a Shelf Service Processor, or Shelf Service Processor (SSP) 74.

[0136] FIG. 12 provides an overview of the functional components of the CSSP 71 including functional components of the Switch 73 and functional components of the SSP 74. In the present example, most of the components relating to the Switch 73 are mounted on a Switch PCB 231, and the components relating to the SSP 74 are provided on a SSP PCB 232. However, it should be noted that the components located in the lower portion of the switch PCB 321 (i.e., that portion below the SSP PCB 232 as illustrated in FIG. 12 logically belong to the SSP 74, rather than to the switch 73. It will be appreciated that such component arrangements are not compulsory for successful operation and that any other component arrangement over any number of component boards can be easily achieved using conventional component arrangement techniques.

[0137] Firstly, with reference to FIG. 12, there follows a description of functional elements of the Switch portions 73 of a CSSP 71 as contained within the CSSP enclosure 121.

[0138] The midplane connector 141 on the CSSP 71 establishes the connection between the CSSP 71 and the midplane 171. In the present example, it supports up to 84 connections (pins) that will deliver SERDES outputs 265-268, I2C signals 310, 320, 321 and 322, and power 278, 279. Signal connections may be made through two 20-pair right-angled connectors. Power connections may be made through a right-angled connector. The connector can be configured to facilitate hotswapping of the board, for example with a low insertion force. The connector also uses guide pins to increase the ease of serviceability and prevent module misalignment during insertion.

[0139] A switch microprocessor 240 is provided, in the present example the microprocessor used is a Power PC (MPC8245) packaged in a 352 pin Tape Ball Grid Array (TBGA) package. This microprocessor 240 supports between 1 MB and 2 GB of address space in the present example. It further includes an Embedded Programmable Interrupt Controller (EPIC) that provides 5 hardware interrupts (IRQs) or 16 serial interrupts. There are 4 programmable timers with cascade mode function. DRAM memory for the processor can be provided in the present example by a commodity DIMM 242. The processor 240 can be connected to a 32 bit PCI bus 241, which operates at, for example, 33 MHz/66 MHz.

[0140] A clock input to the processor 240 can be provided by a clock generator (CLK) 243. The CLK 243 can include a configurable clock generator (not shown) implemented as a programmable clock synthesiser employing a crystal used to produce CPU clock signals. The clock frequency can be determined by jumper settings (not shown). A vectored interrupt controller (I-Chip) (not shown) and a configurable core voltage regulator module (VRM) (not shown) can be provided that operate substantially as described above with reference to the like components of FIG. 11.

[0141] In the present embodiment two switch ASICs (application specific integrated circuits) 244, 245 are provided (in the present example, BCM5632 Gigabit switch ASICs). Each ASIC can provide twelve GMII Interfaces (1 Gigabit Ethernet) (for uplinks and downlinks) and one 10 Gb XGMII interface for chip-to-chip communication (bridging) 246 between the ASICs 244 and 245. Sixteen GMII 1 Gb 'downlinks', in the form of serialized Gb Ethernet data, are provided through four quad SERDES 248-251 to allow each information processing cartridge 43 to communicate with the switch 73. Eight GMII 1 Gb 'uplinks' are provided for external communication through two quad PHYs 253 and 254 (in the present example BCM5404 ASICs) and RJ45 connectors on the rear panel 122. The ASICs 244 and 245 are configured via a PCI interface (32 bit/33 MHz) to the PCI bus 241.

[0142] A Flash PROM 256 can store a real time operating system, and management and configuration data for the microprocessor. The Flash PROM 256 in the present example can be operable to hold 8 MB-16 MB of data, depending on the software required. The flash PROM 256 can be operated via an on-chip XBus 258.

[0143] Also connected to communicate with the processor 240 via the XBus 258, a Real Time Clock (RTC) 259 can be provided for real-time functions with a back-up battery.

[0144] Also connected to the XBus 258 can be a UART (Universal Asynchronous Receiver Transmitter) 260 which in turn connects to a serial bus 261 for providing an asynchronous console connection from the switch 73 to the SSP 74 which can be accessed by the SSP.

[0145] An integrated MAC/PHY (Media Access Control/Physical) switch 271 can provide its own interface to the PCI bus 241. This MAC/PHY switch 271 can connect to a 10/100 Ethernet hub 272. The hub 272 can be operable to provide a management interface to the SSP 74 and a connection from an external management network to the switch 73 and SSP 74 of a given CSSP 71. The connection from the integrated MAC/PHY device 271 to the SSP 74 can be coupled capacitively. A loopback mode can be provided by the MAC/PHY device 271 for system diagnostics. The hub 272 can connect to an RJ45 connector 273 on the rear panel 122 of the CSSP enclosure 121.

[0146] An 8 kByte I2C EEPROM 262 can be used to store the FRU-ID and is accessible by the SSP portion 74 of each CSSP 71 via a serial bus 263 and the midplane 171. The upper 2 kByte of the EEPROM 262 can be configured to be write protected.

[0147] An I2C Redundant Control Register (RCR) 275 can be used to provide an alternate, redundant path for powering-down the CSSP 71 and Shelf Level Indicators 69 mounted on the front 57 and rear 59 panels of the shelf 41. The I2C RCR 275 can be accessible by both the SSP 74 of the CSSP 71 containing the RCR and the SSP 74 of a further CSSP 71 connected via the midplane 171 via an I2C bus 276. In the present example, a device suitable for use as the RCR 275 is a Phillips PCF8574 IC.

[0148] With continued reference to FIG. 12, there now follows a description of functional elements of the Shelf Service Processor (SSP) portion 74 of a CSSP 71 as contained within the CSSP enclosure 121 and provided on an SSP PCB 232.

[0149] In the present example, communication between the Switch PCB 231 and the SSP PCB 232 is facilitated by an interboard connector pair 298 and 299. It supports connections (pins) for I2C signals, 10/100 MAC/PHY output, and power. As described above, the switch PCB 231 carries the components associated with the switch, and it also carries the power, FRU-ID and environmental monitoring components along with the connectors for connections to the midplane 171 and external connectors. Thus, in the present example, all SSP components requiring a connection to the midplane 171 or an external connection have signal paths routed through the connector pair 298, 299 and via the switch PCB 231 to the relevant midplane or external connectors.

[0150] In the present example, the SSP 74 includes a microprocessor 301 (e.g., a Power PC (MPC8245) processor) mounted on the SSP printed circuit board (PCB) 232. The processor 301 can be connected to a PCI bus 302, the present instance a 32 bit bus that operates, for example, at 33 MHz/66 MHz.

[0151] A clock input to the processor 301 can be provided by a clock generator (CLK) 303. The CLK 303 can comprise a configurable clock generator (not shown) implemented as a programmable clock synthesiser employing a crystal used to produce CPU clock signals. The clock frequency can be determined by jumper settings (not shown). A vectored interrupt controller (I-Chip) (not shown) and a configurable core voltage regulator module (VRM) (not shown) can be provided that operate substantially as described above with reference to the like components of FIG. 11.

[0152] The processor 301 can be provided with a DRAM memory 305. The memory capacity can be chosen to suit the processor addressable memory space. In the present example, 8 MB of DRAM memory is provided.

[0153] An integrated MAC/PHY switch 306 can provide its own interface to the PCI bus 302. The MAC/PHY switch 271 can be connected to 10/100 Ethernet hub 272 via the interboard connectors 298, 299. A loopback mode can be provided by the MAC/PHY switch 306 for system diagnostics.

[0154] Octal UARTs 308 and 309 can be connected between the PCI bus 302 and the interboard connector pair 298, 299. The signal path can be continued from the interboard connector pair 298, 299 to serial connections 310 on the midplane connector 141 on switch PCB 231. The Octal UARTS 308, 309 can facilitate serial communications between the SSP 74 and each of the processing cartridges 43.

[0155] Also connected to the PCI Bus 302 can be a dual UART (DUART) 312 that in turn can connect via the interboard connectors 298, 299 to serial bus 261 for providing an asynchronous console connection from the SSP 74 to the switch 73. The DUART 312 can also have an I2C connection to an external connector on the rear face 122 of the CSSP enclosure 121. The external connector can provide a common operating system/boot console and command port 311.

[0156] Connected to the processor 301 via an XBus 314 can be a Flash PROM 315. The Flash PROM 315 can store a real time operating system, and management and configuration data for the microprocessor 301. The Flash PROM

315 can be operable in the present example to hold up to 2 MB of data, depending on the software required.

[0157] Also connected to the processor 301 via the XBus 214 can be a real time clock (RTC) 316 for real-time functions with a backup battery. The RTC 316 can also provide 8 kByte of non-volatile random access memory (NVRAM), in the present instance implemented as an EEPROM. This can be used to contain information such as the FRU-ID, a serial number and other FRU information.

[0158] To facilitate I2C communications between the SSP 74 and the other CSSP 71, the midplane 171 and the PSUs 81, a multiplexer 318 can be provided. The multiplexer 318 can have a single I2C connection to the processor 301 and connections, via the interboard connector pair 298, 299 and the midplane connector 141 to both PSUs 81, the midplane 171 and the other CSSP 71.

[0159] The processor 301 can also comprise an embedded DUART to provide a redundant serial link to the SSP 74 of the other CSSP 71. Although it would be possible to implement this link using an external DUART, the advantage of using an embedded DUART is that the connection to the other CSSP is reliable and therefore likely to be functional. Where the embedded DUART link does not use the I2C Multiplexer for communications to the other CSSP, a common mode of failure for both the SSP-SSP I2C links can be avoided, it being assumed that the processor 301 is likely to be functional even if both embedded DUART channels are non-functional.

[0160] The CSSP 71 can be powered from two, diode commoned, 9V power supply rails 278 and 279. DC/DC converters 281 can be used to provide the voltage levels required by the CSSP 71. The DC/DC converters 281 can be supplied by dual 9V inputs 278, 279, individually fused 285, 286 and then diode commoned 287, 288. A soft start controller 283 can be provided to facilitate hot-insertion. A 5V DC/DC converter (I2C power regulator) 282 can be turned on as soon as the CSSP 71 is fully inserted. A 3.3V DC/DC converter can be turned on when instructed, for example through SSP service software, by asserting low an appropriate signal (ON_L—not shown). The 3.3V converter can be arranged to turn on a converted for 2.5V, 1.2V, and a processor core voltage rail (Vcore) when the voltages are within an appropriate range.

[0161] When the CSSP 71 is inserted the inrush current can be limited, for example to <1A, and the rate of rise can be configured not to exceed a predetermined value (e.g., 20 A/s) to provide a so-called soft start to facilitate hot-insertion. The intent is to prevent damage to the connectors and to avoid generating noise. A soft start controller 283, which controls a ramping-up of voltage levels, can be enabled when the predetermined signal (Inserted_L signal) is asserted low, this signal is on a short pin in the connector and is connected to ground (GND—not shown) through the midplane 171 until one of the supplies is removed. These circuits can be configured to withstand an overvoltage at their inputs whilst the input they are feeding is not powered, without any leakage to the unpowered circuit. A sense circuit can detect if the voltage has dropped below a threshold, for example 2.0V, as a result of a blown fuse, a power rail going down, etc. The DC/DC converters 281 can be protected against short circuit of their outputs so that no damage occurs.

[0162] The I2C regulator **282** can be powered as soon as the CSSP **71** is fully inserted into the midplane **171**. This can be facilitated through short pins connected to the soft start controller **283**, which controls a ramping-up of voltage levels. The other DC/DC regulators can be turned on, for example by SSP software.

[0163] A pair of fans **290, 291** can provide cooling to the CSSP **71**. The fans **290, 291** can be configured to run at full speed to prevent overtemperature conditions by minimizing the temperature of the internal components and the fan. The speed of the fans **290, 291** can be monitored by the SSP **74** through an environmental monitor **295** on the switch board **231**. The environmental monitor **295** can be alerted in the event of the fan speed falling below a predetermined value (e.g., 80% of its nominal speed). The fan can provide tachometer outputs to facilitate the measurement of fan speed.

[0164] LED indicators **137** can be provided, for example with a green power LED, an amber LED for indicating that service is required and a blue LED for indicating that the switch is ready to be removed. LED indicators integrated on 2x4 stacked RJ45 connectors on the rear face of the CSSP **71** can be arranged, for example, to show green continually when the link is present and flash green when the link is active.

[0165] The environmental monitor ENV MON **295** can be provided to maintain operational integrity of the CSSP **71**. The ENV MON **295** can include limit values in limit registers and can monitor, for example, temperature within the CSSP enclosure **121**, the CSSP power rails, including the 12V, 3V3, Switch Processor Core Voltage, CSSP Processor Core Voltage and the two 9V power feed rails **278, 279** from the midplane **171**. The outputs of the DC/DC converters **281** can be fed in to A/D inputs of the ENV MON **295** for Watchdog comparisons to be made to the voltage limits set in the limit registers. As noted above, the ENV MON **295** can also monitor the operating speeds of the fans **290** and **291**. The ENV MON **295** can communicate with the SSP **74** of both CSSPs via an I2C bus **296**.

[0166] For IO to the midplane **171** shown in FIGS. 8A-10, the midplane connector **141** can include sixteen 1 Gb Ethernet connections **265-268** from four quad SERDES **248-251** and the I2C bus lines **596**.

[0167] The SSP **74** can access the I2C devices (FRU-ID EEPROM, 8-bit I/O expansion chip, and the system hardware monitor) through the midplane **171**.

[0168] For external IO, rear panel Gb Ethernet connections can be provided from the two quad PHYs **253, 254** to 2x4 stacked RJ45 connectors **139** (to give 8 uplinks). Each port can be an independent 10/100/1000 BASE-T (auto negotiating) port. The PHY devices **253, 254** can operate in GMII mode to receive signals from the 8-Gigabit interfaces on the ASICs **244, 245**.

[0169] The Power Supply Units (PSUs) **81** can be configured such that when two or more PSUs **81** are connected in parallel in the shelf **41**, failure of any one of the paralleled units shall not affect system operation. Moreover, one of the PSUs can be installed or removed from a "live" system with or without input power applied. The outputs can have overcurrent protection.

[0170] The PSU can have an I2C interface to provide power supply status via the midplane **171**. The PSU can have an internal temperature sensor that reports via the I2C interface. The PSU fan speed can also be monitored and errors are reported via the I2C interface. Overvoltage and overcurrent sensors can also report via the I2C interface.

[0171] There now follows a description of aspects of an example of a power supply **81** with particular reference to FIG. 13.

[0172] When a power supply (e.g. mains power, or UPS type protected power) is connected to the cable connector **83**, transformer, regulator and rectifier circuitry **400** can operate to generate a DC output (in the present example, 12V DC) from the input (in the present example 230/240V 50 Hz AC or 110 V 60 Hz AC).

[0173] In order to ensure good cooling reliability within the shelf **41**, each PSU **81** can have a pair of cooling fans **402, 403** located at the rear of the PSU enclosure as described above with reference to FIG. 7. As a failsafe measure against a failure of one PSU **81**, the fans of each PSU **81** can be powered by both PSUs **81**. Thus, in the event that one PSU **81** is non-operative to produce the DC supply for the shelf **41**, as long as the other PSU **81** is operative, not only will all components of the shelf **41** be powered as normal, the fans of both PSUs **81** can continue to run.

[0174] As shown in FIG. 13, this dual powering of cooling fans **402, 403** can be effected by providing a power supply line **404** from the transformer, regulator and rectifier circuitry **400** to power both fans **402, 403**. Also, first and second separate power lines **410, 412** from the other PSU **81** can provide duplicate power supply to the first and second fans **402, 403** respectively. The fan **402** can thus be powered by a diode commoned supply from line **404** and a diode commoned supply from line **410**. Diode protection can be provided by diodes **405** and **411** respectively. The speed of the fan **402** can be controlled by a speed controller **408**. Similarly the fan **403** can be powered by a diode commoned supply from line **404** and a diode commoned supply from line **412**. Diode protection can be provided by diodes **406** and **414** respectively. The speed of the fan **403** can be controlled by a speed controller **409**.

[0175] The two speed controllers **408, 409** can in turn be controlled by a data input from each CSSP **71** received via an I2C bus connection (not shown in FIG. 13). Power supply lines carrying DC power for the other FRUs of the shelf **41** are shown in FIG. 13 as power line **416**. All power connections to and from the PSU **81** can connect to the midplane **171** when the PSU is inserted in the shelf **41** via the midplane connector **163**. In the present example the PSU **81** connects to the shelf through a 5P/24S/6P configuration SSI-MPS compliant right angle connector **163** at the front face **147** of the PSU **81**. Connectors for the I2C interface can also be provided.

[0176] The input power line **410** and **412** for each fan **402** and **403** can be provided with a softstart module **4131** and **4132** respectively, to allow for hot insertion of the PSU **81** into the shelf **41**. The softstart modules **4131** and **4132** can be controlled, for example, by pulling a signal to ground (e.g., a "mated" input line **4151** and **4152**).

[0177] Where the two input power lines **410** and **412** are separate lines having separate softstart provision, there is no

common failure mode for the backup method of powering the fans 402, 403. Thus even if the PSU 81 ceases to be operable to generate the DC supply, and a component (power line or softstart module for example) fails in the supply path from the second PSU 81 to the fans 402, 403, at least one of the fans 402, 403 can remain operational as the shelf 41 still receives the cooling effect of three PSU fans.

[0178] In the present example, the power supply has four rear panel LED indicators 137. A blue "Ready to Remove" LED can be driven by the I2C interface and indicate that the power supply may be removed from the system. An amber "Service Required" LED can be driven by the I2C interface and indicate that the power supply is in a fault condition: any output out of range, over-temperature or shutdown. A green "DC Output-OK" indicator can be driven by internal power supply circuits and show that the main 12 volt supply is functioning. The LEDs can remain lighted when individual outputs are in the current limited mode of operation. A green "AC Input-OK" indicator can be driven by internal power supply circuits and show that AC input power is within normal operating range.

[0179] With reference to FIG. 14, there will now be described an example of data connectivity between the FRUs and midplane of the shelf 41. Power transmission paths are not illustrated in FIG. 14. However, it will be appreciated that to facilitate the maximum component redundancy of the shelf 41, each PSU 81 can independently provide power to each FRU.

[0180] In the present example each of the processing cartridges (blades) 43 connects to the midplane 171 via a pair of information signal connections (e.g. Gb Ethernet links) 224, 225 and a pair of serial management signal connections 226, 227. Connections within the midplane 171 can ensure that each Ethernet link 224 is directed to a connection 265-268 from the midplane 171 to a first switch 73, and that each Ethernet link 225 is directed to a connection 265-268 from the midplane 171 to a second switch 73. Thus one Ethernet link can be established between each processing cartridge 43 and the switch 73 of each CSSP 71. Further connections within the midplane 171 can ensure that each serial connection 226 is directed to a connection 310 from the midplane 171 to the first SSP 74 and that each serial connection 227 is directed to the second SSP 74. Thus one serial link can be established between each processing cartridge 43 and the SSP 74 of each CSSP 71. As mentioned earlier, information signal connections other than Gb Ethernet connections (e.g. Infiniband connections) could be employed in other examples.

[0181] A plurality of serial connections can connect each SSP 74 to the other. Serial lines 320, 321 can connect each SSP 74 to the midplane 171 and connections within the midplane can connect the two sets of lines together. To provide a control interface from the SSPs 74 to the PSUs 81, serial lines 322 can connect each SSP 74 to the midplane 171 and connections within the midplane 171 can connect to serial lines 324 from the midplane 171 to each PSU 81.

[0182] An example of data and control connectivity of the shelf 41 to and from computer systems external to the shelf 41 when the shelf 41 is arranged for use within a multiprocessor server system such as that described above with reference to FIG. 1 will be described with reference to FIG. 15.

[0183] As summarised above with reference to FIG. 14, in the present example each processing cartridge, or blade, 43 is connected to the switch 73 of each CSSP 71 by an information signal connection (e.g. a 1 Gb Ethernet link) formed by a combination of links 224, 225 from the processing cartridge 43 to the midplane 171, connections within the midplane 171 and links 265-268 from the midplane 171 to each switch 73.

[0184] Further, in this example a set of serial management signal connections comprising links 320, 321 and connections within the midplane 171 connect the SSP 74 of each CSSP 71 to the SSP 74 of the other CSSP 71.

[0185] To provide external data connectivity between the shelf 41 and an external core data network 330, in association with which all information processing performed by the processing cartridges 43 of the shelf 41 is undertaken, connections 331 can be formed between the core data network 330 and the eight 1 Gb Ethernet ports 139 provided on the rear panel 122 of the CSSP enclosure 121.

[0186] In the present example, the connections by means of which control and configuration of the shelf 41 are performed are entirely separate to the connections to the core data network 330. Therefore, a first external switch 335 can connect to a management (I2C) port 273 of the first CSSP 71 and a second external switch 336 can connect to a management (I2C) port 273 of the second CSSP 72. As described above with reference to FIG. 12, the management port 273 can provide a management network interface to both the switch 73 and SSP 74 of each CSSP 71. The external switches 335, 336 can each be connected to each of a pair of System Management Server (SMSs) 338, 339. The SMS is not essential to the operation of the shelf 41, but use thereof aids optimal operation of the shelf 41. In a typical multiprocessor server system a plurality of shelves 41 may be connected together via the core data network 330 under the control of a single management network utilising one set of SMSs 338, 339. A set of SMSs 338, 339 may comprise a single SMS (as well as a plurality thereof). However use of at least two SMSs enables redundancy of components, therefore increasing overall system reliability.

[0187] A serial interface control 343 operable under telnet protocol control is also connected to the shelf 41 in the present example. This can provide a common operating system/boot console connection to the SSP 74 of both CSSPs 71 via the RJ45 connector 311 on the rear panel 122 of each CSSP enclosure 121.

[0188] It will be appreciated from the above that a flexible and scalable modular computer architecture has been described. In the described example up to 16 information processing cartridges, or blades 43, can be configured as sealed FRUs on a single shelf 41, the number of blades being chosen according to customer requirements. Each blade has its own processor and random access memory. If, for example, there is a maximum of 2 Gbytes of memory per information processing cartridge, and one processor per blade, 16 processors (16P) with 5.33 processors per unit height (1U) and a total of 32 GB of memory per shelf can be provided.

[0189] In the present example, the shelf 41 incorporates redundant combined switch and shelf service processor modules (CSSPs) 71 and redundant power supply units

(PSUs) **81** separate from the blades **43**. As the power supplies are carried by the shelf, the information processing cartridges can be kept compact and inexpensive. Also, as a result, they can be powered by DC power only, via the midplane **171**.

[**0190**] Also, as mentioned earlier, the FRUs (e.g., the information processing cartridges, or blades, **43**, the CSSPs **71** and the PSUs **81**) can all be configured as sealed units that do not contain any internal FRUs themselves and do not contain user serviceable items. The enclosures of the FRUs can be arranged to enclose all of the functional components of the FRU with only electrical connectors being externally accessible and with indicator LEDs being externally visible as well.

[**0191**] These factors can all contribute to keeping the cost of the FRUs low, as well as that of the overall system. The modular approach with the use of sealed modular field replaceable units for providing system functionality and with non-field replaceable units designed with a minimum possible number of active components enhances reliability. Moreover, easy and rapid maintenance is facilitated in the event of a failure of a FRU by simple replacement of that FRU, further reducing the cost of ownership.

[**0192**] Thus, it will be appreciated from the above description that the provision of a rack mountable shelf, that includes power supplies, a shelf service processor and switches in modular units, for carrying a number of processing cartridges, wherein the number of processing cartridges can be chosen according to customer requirements, provides a flexible and scalable computer configuration. The balancing of the load between the processors of the processing cartridges can be effected by software using conventional principles.

[**0193**] A configuration as described provides an easily scalable processor architecture, whereby the processing power provided by a complete system based on the information processing cartridge/information processing cartridge carrier architecture can be scalable from moderate to very high capacity through the simple addition of further information processing cartridges.

[**0194**] As illustrated in **FIG. 16**, an example of the external connections from a shelf **41** can be in the form of two active information signal connections (e.g., Ethernet connections) **350** and **351**, two active power connections **353** and an active/standby pair of management connections **354**. With regard to the management connections, each connection comprises a serial connection and a network (e.g. Ethernet or Infiniband) connection. It is possible to connect to either the active or the standby connection, as the incoming signal will be internally routed to whichever management controller (CSSP) is the current master. It will be appreciated, therefore, that the connections to a shelf can be kept to a minimum. It will further be appreciated from the configuration shown in **FIG. 16** that the system is scalable beyond a single shelf unit **41**.

[**0195**] **FIG. 17** illustrates how a plurality of shelves can be configured within one (or more) racks to provide even higher processing power. Such a constellation of shelves to provide a large grouping of servers is sometimes termed a "web farm" or "server farm"**360**. As shown in **FIG. 17**, the web farm comprises a plurality of shelves **41** that each carry

a plurality of blades **43**. Also provided are a plurality of Network Attached Storage devices (NAS) **373** for providing storage for critical data, e.g. email data storage, for the web farm. The NASs **373** are not required if there is no critical data to be stored, e.g. if the web farm is operating solely to provide web caching services.

[**0196**] Management control of the web farm **360** can be provided through a pair of System Management Servers (SMSs) **362**. Each SMS **362** can be connected to a management network via a link **366** and to a management console **365**. The SMSs **362** can communicate with the individual shelves **41** via a pair of management switches **364**. Each shelf **41** and NAS **373** can be connected to each management switch **364** via a connection **367**. Thus dual redundant management connections can be provided to each shelf **41** and NAS **373**.

[**0197**] Flow of data to and from the web farm **360** can be provided through a pair of data switches **369**. Each data switch **369** can be connected to a consumer network via a link **370**. It is to be understood that the consumer network can be a larger data network to which the web farm **360** is connected. This network can be an office or corporation intranet, a local area network (LAN), a wide area network (WAN), the Internet or any other network. Connections between the data switches and the shelves **41** can be facilitated by connections **371**. It is to be noted that as each shelf has its own switching capability, there is no need for each shelf **41** to be directly connected to the data switches **369**. Connections can also be provided to connect the NAS units **373** to the shelves **41**. The topology used for interconnection of the data switches **369**, shelves **41** and NASs **373** can be any topology providing at least one connection of any length between every possible pair of units. Complex topologies arranged to minimise the maximum connection length between any two given units in the web farm can be used.

[**0198**] The web farm **360** comprising a plurality of shelves **41** with or without a plurality of NASs **373** can suitably be used as any or all of the entry edge server group **9**, web edge server group **15** and application servers **19** described above with reference to **FIG. 1**.

[**0199**] As an alternative to providing critical data storage within a NAS **373**, such storage can be provided within one or more NAS cartridges fitted into one or more of the shelves **41** in place of processing cartridges **43**. Another alternative is to provide a server shelf with local storage (such as a RAID array (Redundant Array of Inexpensive Disks) in place of the NAS **373**.

[**0200**] Thus there has now been described an example of a fully configurable computing system based on a plurality of self contained field replaceable units (FRUs) and scalable from a single processing cartridge with power supply and switching capability to a multiply redundant multiprocessor server system with full system management capability extending over a number of co-operably connected server shelves. It will of course be readily apparent to the skilled reader that many of the specific features specified in the above description are in no way limiting and a variety of alternatives may be produced using only ordinary skill and common general knowledge. Non-limiting examples of example modifications which may be made to the above described system are discussed hereafter.

[**0201**] There is no limit placed on the processing cartridges as to what software they should run. Each module

within a shelf or farm may run under the same operating system, or a plurality of different operating systems may be used. Examples of possible operating systems include Sun Microsystems' Solaris® OS or another UNIX™-Type OS such as Linux™, MINIX™, or Irix™, or UNIX™ or a Microsoft OS such as Windows NT™, Windows 2000™, Windows ME/98/95™, Windows XP™.

[0202] It is also not necessary that each processing cartridge within a shelf or farm be configured to run the same program software. For example, individual processing cartridges may be configured to execute, for example, fileserver software, mailserver software, webhosting software, database software, firewall software, or verification software.

[0203] Although it has been described above with reference to FIGS. 4, 8, 12, 13 and 14, that functionality of a switch and of a shelf service processor should be provided within a single combined switch and service processor unit, this is not essential and separate switch and shelf service processor field replaceable units may be used.

[0204] Although it has been described above that a pair of PSUs and a pair of CSSPs may be provided so as to enable dual-redundancy, further PSUs and CSSPs may be provided so as to increase FRU redundancy further, thus providing statistically higher reliability.

[0205] In the power supply circuitry in each of the blades and CSSPs, two voltage sense circuits may be provided after the fuses and before the diodes, to prevent a latent fault caused by a failed fuse going undetected until one of the PSUs is removed or taken offline. Such circuits may be configured to withstand an overvoltage at their inputs whilst the input they are feeding is not powered, without any leakage to the unpowered circuit.

[0206] Although it has been described above with particular reference to FIG. 11 that the processing module may be based on an UltraSPARC™ processor, this is not limiting and any other processor having sufficient processing capacity to undertake the tasks required of a particular processing cartridge may be used. Alternative processors include, but are not limited to, Intel x86 series and compatible processors, AMD x86 compatible processors, Alpha processors and PowerPC processors. The particular example of an x86 compatible processor is described in more detail with reference to FIG. 18. In FIG. 18, the parts corresponding to those of the UltraSPARC™ based system of FIG. 11 have the same reference numerals and will not be described again here. In a system based on an x86 compatible processor, the processor 378 itself communicates with the other components, including the memory 196 and PCI bus 198 via a Northbridge 379. The Northbridge 379 also includes an interrupt controller, so no separate interrupt concentrator is required. The other components of the processing cartridge could be substantially the same as for the UltraSPARC™ based system described above.

[0207] Although it has been described above that each information processing cartridge comprises a single micro-processor, this is not a limiting case as each or any of the information processing cartridges may have more than one microprocessor arranged to share common storage resources to operate synchronously (in lockstep) or asynchronously. Also, it is not necessary that all information processing cartridges inserted into a shelf at a given time are identical, rather a variety of different blade architectures may be used simultaneously.

[0208] The provision of the functions of both Switch and Shelf Service Processor within a single FRU in the present example provides a facility within a single shelf 41 for dual redundancy in both functions in fewer different FRUs. As will be appreciated, there is no restriction that these two functions must be provided within a single FRU and division of the two functions into separate FRUs would present no difficulty to the skilled addressee.

[0209] The backup power provision for the cooling fans of the PSUs is described above with reference to FIG. 13. Although it is described that the backup power supply to each fan should be independent of the other, if the risk of common mode failure of backup power-supply is judged to be low, or is of low importance, then the backup supply to each fan may be provided in common with the backup supply to all other fans.

[0210] Also, an information processing module forming a field replaceable server blade can include a processor and memory can be configured by means of software, firmware or hardware to provide a special purpose function. By way of examples only, an information processing module can be configured to perform the function of one or more of a firewall, or a load balancer, encryption and/or decryption processing, an interface to a secure network, e.g. a virtual private network (VPN), a specialized switch with wide area network (WAN) connectability.

[0211] Also, a storage blade may be provided. The storage blade can be configured to be mountable in a server blade receiving location in a blade server carrier. The storage blade can comprise storage blade connectors configured for interconnecting with carrier connectors on the server blade carrier, whereby the storage blade is interchangeable with a server blade. A carrier, or shelf, for a server system can be arranged with a plurality of blade receiving locations for receiving blades, wherein the blades can be storage blades or information processing blades. The server system can be self configuring on receipt of the blades according to the type of blade received in each said location. To achieve the blade service controller in each blade can be operable to communicate with a shelf service processor to perform said configuring.

[0212] Although it has been described above that one or more standard processing cartridges 43 may be inserted into a shelf 41, there may arise situations where a standard processing cartridge 43 may not always provide an optimum performance situation. Computer systems require management in many different ways, for example, load distribution, access control, secure transaction management and many other functions which may be performed with greatest reliability and/or speed by dedicated hardware. That is not to say that such functions may not be performed by a standard processing cartridge 43 programmed using appropriate application software, merely that specialist hardware (in the form of a non-standard processing cartridge) may provide reliability, performance and/or cost benefits.

[0213] Intrusion detection provides operational reliability, security and availability benefits to server systems where more than one individual server is networked together. Intrusion detection is the process of monitoring for and detecting unauthorized accesses to the networked computer system. By means of such monitoring and detection, unau-

thorized accesses to the computer system may be detected and terminated to prevent possible interruption or damage to the computer system.

[0214] A number of commercial and other intrusion detection software packages are generally available. Examples of such packages include the Manhunt application from Recourse Technologies Inc., the SecureNet suite of products from Intrusion Inc. and the Intrusion Detection Expert System (IDES), the Next-Generation Intrusion Detection Expert System (NIDES) and Event Monitoring Enabling Responses to Anomalous Live Disturbances (EMERALD) products from SRI International. Each of these packages performs the same general functions, that is monitoring for intrusions into a network. Such intrusions may be accesses allowed by an error in an access management system such as a firewall or they may be accesses gained through subversive or illicit means. The intrusions may be benign or may be associated with a deliberate attack on a network or computer connected thereto.

[0215] An intrusion detection system may perform one or more of a number of different intrusion detection functions. A first examples of such a function is detection of unauthorized accesses or intrusions. Detection methods may include protocol anomaly detection, traffic rate monitoring, evasion sensing, misuse detection protocol state tracking, IP packet reassembly and signature checking. Also, an intrusion detector may be configured to check for various types of port scanning, including stealth port scanning.

[0216] An intrusion detection system may be further configured to analyze results of intrusion detection functions. Such analysis may enable correlation of isolated events to produce a higher level model of network security events to enable the extent of a particular attack or intrusion to be discovered and to allow development of network security practice to reduce the risk of future security breaches.

[0217] Further capabilities which may be provided in an intrusion detection system include responses to detected intrusions. Such responses may be configured on a policy basis and may operate to contain and control an intrusion. Possible responses may include tracing of spoofed (hidden or cloaked) IP addresses back to the genuine source, quality of service route filtering to mitigate the effects of mass traffic denial of service attacks and session termination. Other responses may include logging and reporting of detected events. Reports may be made on a per time basis or on a per event basis or on a hybrid of the two dependent upon an importance criterion allocated to each detected event. Reports and alerts may be made via email or over a management network.

[0218] In the context of the above description of a modular computer system based around a shelf 41, a processing cartridge may be configured to perform an intrusion detection function. This may be achieved by installing intrusion detection software onto a generic processing cartridge 43, or alternatively by providing a specialist hardware processing cartridge also installed with intrusion detection software. A further option is to provide intrusion detection functionality in a firmware format within a processing cartridge. However, the information processing cartridge 43 may typically be overspecified for the performance of such a function and so a specific hardware solution may be used. Examples of dedicated hardware processing cartridges are shown in

FIGS. 19 and 20. Such dedicated processing cartridges, when programmed with an operating system and appropriate application software, may be referred to as appliance processing cartridges, appliance blades, or appliances.

[0219] FIG. 19 shows a processing subsystem for a dedicated hardware processing cartridge based around an x86 compatible processor such as an Intel Pentium™ or Celeron™ series processor, or an AMD Athlon™ or Duron™ series processor. The processor 378 is connected to a North Bridge 379 as described above with respect to FIG. 18. The north bridge 379 provides interrupt handling and memory management. Thus the processor 378 accesses the memory 196 via the north bridge 379. In the present example, the north bridge 379 communicates with the south bridge 199 via a dedicated bridge link 605. The dedicated bridge link 605 provides a dedicated high speed link between the south bridge (which handles most I/O tasks and the PCI bus) and the north bridge (which handles memory management and interrupt control). A number of dedicated bridge link technologies exist, many of which are proprietary to a particular chipset manufacturer. Examples of dedicated bridge link technologies include V-Link™ from VIA Technologies Inc. and MuTIOL™ from Silicon Integrated Systems Corporation (SIS). Alternatively, the bridge to bridge link could be performed by a PCI bus link.

[0220] The south bridge 199 handles the PCI bus 198, which in the present example connects the south bridge 199 to a dual Ethernet interface with integrated SERDES (serializer/deserializer) 610 which provides the network connections to the switches 73 of the CSSPs 71 via the cartridge midplane connector 120. The south bridge 199 also connects with a Super IO device 617 via an LPC (low pin count) bus 615. The super IO device 617 provides an interface to a flash memory 619. The flash memory 619 stores the operating system and application software for the processing cartridge. The south bridge 199 also has an XBus interface to an XBus 200 which links the south bridge 199 to the blade service controller (BSC 203). The BSC operates as described above with reference to FIG. 11 and therefore will not be described again here.

[0221] Other components differing from FIG. 11 include the fact that the boot information formerly stored in a PROM attached to the XBus is in the present example stored in the Flash memory 619, which may be accessed by the BSC 203 via a serial link 206 to the Super IO device 617. Also, the clock generation is, in the present example performed by a clock generation module 193 attached to the I2C link 197 from the south bridge 199. All other components may behave as described above with reference to FIG. 11.

[0222] Thus FIG. 19 shows the main functional components of a first example of a dedicated appliance blade. A further example of a dedicated appliance blade is shown in FIG. 20.

[0223] FIG. 20 shows an example of a processing subsystem for a dedicated hardware processing cartridge based around a PowerPC series processor. The processor 710 connects directly to the PCI bus 198 to connect to the dual Ethernet with integrated SERDES 610 which provides network connections to the switches 73 of the CSSPs 71. Also connected to the processor 710 is the random access memory 196. The processor 710 also has direct access to a flash memory 619 which is used to store the boot informa-

tion, operating system and application software for the processing cartridge. The processor is directly linked to the BSC 203 via XBus 200 and serial link 206. The BSC 203 and components attached thereto operate in may operate as the like components described with reference to FIG. 11 above and therefore will not be described again.

[0224] Thus FIG. 20 shows the main functional components of a second example of a dedicated appliance blade. As will be appreciated, other blade components groups and arrangements may be provided for processing cartridges based on the above or alternative central processors.

[0225] A processing cartridge (whether of the type describe with respect to FIG. 11, 18, 19 or 20 or any other type) may be configured as an intrusion detection module and received within a computer system shelf 41 along with other processing modules. The intrusion detection module therefore is provided with all of the above described benefits of such a computer system arrangement. In particular, the intrusion detection module is served by the same management and control entities as other modules received in the same chassis 47, thus failure of the intrusion detection module may be immediately reported to all other modules to enable those modules to take mitigating action, such as running in a more defensive mode, which may include preventing any remote logins for example. Also, the intrusion detection module is able to use the management connections to immediately inform other modules upon a detected abnormality with the network such that the abnormally functioning module may be ignored by other modules until such time as it is correctly functioning again. The management connection also allows for automated reporting without the use of email of detected events and abnormalities, thus sidestepping email delays in raising an alarm and fixing a problem. Also, since all the modules within a given shelf 41 are linked by hardwired connections through the midplane 171, the network integrity assurance module is unlikely to be accidentally disconnected from the network, and bypassing of the intrusion detection module by making an unauthorized physical link into the network is prevented.

[0226] In order to increase the reliability of an intrusion detection processing cartridge, it may be advantageous to use non-standard hardware and/or operating system software. By using a non-standard operating system, for example a real-time operating system such as VxWorks™, Lynx™ or QNX™, various benefits may be achieved. Firstly, a less powerful cartridge processor may be required compared to a cartridge running on Solaris™, Windows™, or Unix™/Linux™ for example. Secondly, such real-time operating systems are less vulnerable to common attacks on computer systems as many such attacks are directed against mass-adopted operating systems. Another possible advantage is that a real-time operating system and intrusion detection software package may require little enough storage within the cartridge that they may be installed and run from solid state memory such as a flash memory installed in the cartridge such that there is no requirement for a hard disk drive within the cartridge. Thus cheaper and simpler hardware may be provided within an intrusion detection cartridge relative to that provided in the generic processing cartridge 43 described above. Of course, such reduced software or hardware is merely optional and any processing cartridge may be configured to perform intrusion detection.

[0227] Thus there has now been described a modular computer system module arranged to perform intrusion detection operations for other computer system modules. The intrusion detection module may be fitted into a modular computer system shelf along with any combination of other computer system modules. The intrusion detection module may serve to increase the operating reliability, security and availability of the computer system as a whole. As will be appreciated, many modifications and equivalents to the above described arrangement may be made without departing from the spirit and scope of the invention as defined by the appended claims. Specific examples of some possible modifications are presented hereafter.

[0228] Although it has been described above that a processing cartridge configured as an intrusion detection cartridge may be configured to run under a real-time operating system, this is not essential and any other operating system may be used.

[0229] As the skilled addressee will appreciate, it is not essential that a network intrusion detection be configured only to perform intrusion detection functions. While the cartridge may be a dedicated unit, it may be configured to perform additional functions, for example general service provision, or another more specialized function such as virus detection or network integrity assurance.

[0230] Although the embodiments above have been described in considerable detail, numerous variations and modifications will become apparent to those skilled in the art once the above disclosure is fully appreciated. It is intended that the following claims be interpreted to embrace all such variations and modifications.

What is claimed is:

1. A server blade comprising at least one processor and a network interface configured to be connected to a network remote to the server blade, the server blade being configured to detect an access to the network, the server blade being further configured as a field replaceable unit.
2. The server blade of claim 1, comprising an enclosure which encloses the at least one processor.
3. The server blade of claim 1, configured to detect an unauthorised access to the network.
4. The server blade of claim 1, configured to detect an undesired access to the network.
5. The server blade of claim 1, configured to detect an intrusion into the network.
6. The server blade of claim 1, configured to detect an attack on the network.
7. The server blade of claim 1, wherein the detection comprises at least one of protocol anomaly detection, traffic rate monitoring, protocol state tracking, IP packet reassembly, evasion sensing, misuse detection, and port scan detection.
8. The server blade of claim 1, configured to perform response processing in response to detection of an access event.
9. The server blade of any claim 8, wherein the response processing comprises storing a record of a detected access event in an event log.
10. The server blade of claim 9, configured to analyse the event log to detect a pattern between detected access events.
11. The server blade of claim 10, configured to determine an attack type based on a detected pattern.

12. The server blade of claim 8, wherein the response processing comprises reporting of a detected access event to a higher level management entity.

13. The server blade of claim 12, comprising a management communication interface operable to transmit a report.

14. The server blade of claim 13, wherein the management communication interface is distinct from the network interface.

15. The server blade of claim 8, wherein the response processing comprises at least one of IP address tracing, quality of service route filtering and session termination.

16. The server blade of claim 1, comprising a solid state memory arranged to store operating software for the server blade.

17. The server blade of claim 1, configured as an intrusion detection blade.

18. The server blade of claim 1, configured as an appliance.

19. A server blade comprising processor means and network interface means for connecting to a network remote to the server blade, the server blade being for detecting an access to the network, the server blade being further configured as a field replaceable unit.

20. A modular computer system comprising:

a carrier operable removably to receive a plurality of computer system modules therein;

a plurality of information processing modules removably received in the carrier, each module having a communications port operable to connect to a communications network internal to the carrier;

a switch operable to connect to the internal communications network to distribute information messages

between the modules and to connect to an external communications network; and

an access detection module removably received in the carrier and operable to connect to the internal communications network to detect an access to the internal communications network.

21. The modular computer system of claim 20, comprising a service processor operable to provide a service function for the processing cartridges received in the carrier, and configured to receive a report of a detected access event from the access detection module.

22. A modular computer system comprising:

carrier means for removably receiving a plurality of computer system modules therein;

a plurality of information processing modules removably received in the carrier means, each module having communications means for connecting to a communications network internal to the carrier;

switch means for connecting to the internal communications network for distributing information messages between the modules and for connecting to an external communications network; and

an access detection module removably received in the carrier means for connecting to the internal communications network for detecting an access to the internal communications network.

* * * * *