



US 20170079247A1

(19) **United States**

(12) **Patent Application Publication**  
**Womble et al.**

(10) **Pub. No.: US 2017/0079247 A1**

(43) **Pub. Date: Mar. 23, 2017**

(54) **METHOD AND SYSTEM FOR REMOTE MONITORING, CARE AND MAINTENANCE OF ANIMALS**

(71) Applicants: **Krystalka R. Womble**, Dallas, TX (US); **Robert L. Piccioni**, Rowlett, TX (US)

(72) Inventors: **Krystalka R. Womble**, Dallas, TX (US); **Robert L. Piccioni**, Rowlett, TX (US)

(21) Appl. No.: **15/365,895**

(22) Filed: **Nov. 30, 2016**

**Related U.S. Application Data**

(63) Continuation-in-part of application No. 14/823,859, filed on Aug. 11, 2015, now Pat. No. 9,538,728, which is a continuation of application No. 14/191,244, filed on Feb. 26, 2014, now Pat. No. 9,131,660, which is a continuation of application No. 13/892,292, filed on May 12, 2013, now Pat. No. 8,707,900.

(60) Provisional application No. 61/848,437, filed on Jan. 4, 2013, provisional application No. 61/702,856, filed on Sep. 19, 2012.

**Publication Classification**

(51) **Int. Cl.**  
*A01K 27/00* (2006.01)  
*G06K 9/00* (2006.01)  
*H04N 5/77* (2006.01)  
*A01K 29/00* (2006.01)  
*A01K 15/02* (2006.01)

(52) **U.S. Cl.**  
 CPC ..... *A01K 27/009* (2013.01); *A01K 29/005* (2013.01); *A01K 27/001* (2013.01); *A01K 15/022* (2013.01); *A01K 15/023* (2013.01); *A01K 27/002* (2013.01); *A01K 15/029* (2013.01); *H04N 5/772* (2013.01); *G06K 9/00228* (2013.01)

(57) **ABSTRACT**

A system for remote care of an animal includes a robotic animal caregiver that includes a housing, a wireless data communication system disposed within the housing and wirelessly communicatively coupled with an external data communications system, and a microprocessor in communication with the wireless data communication system disposed within the housing. The system further includes a smart collar to be worn by the animal operable to determine a geo-location information of the animal and communicate with the microprocessor.

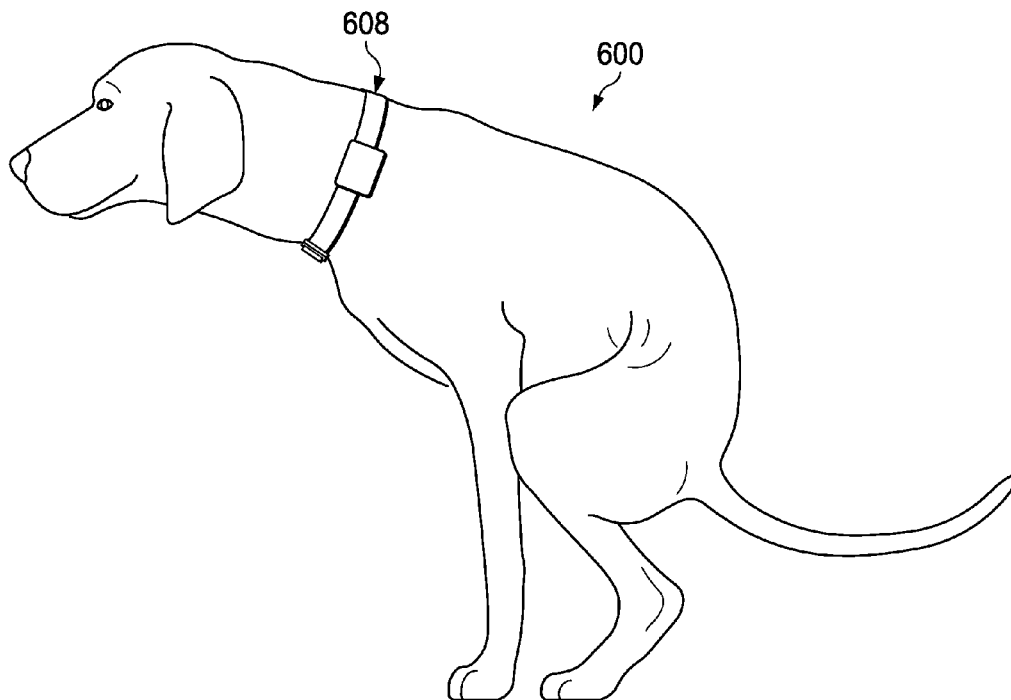

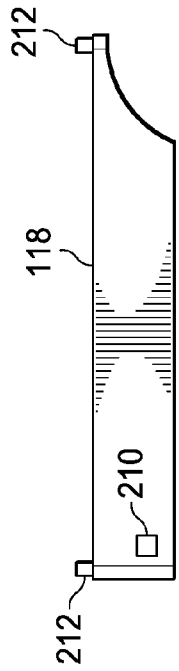

FIG. 2A

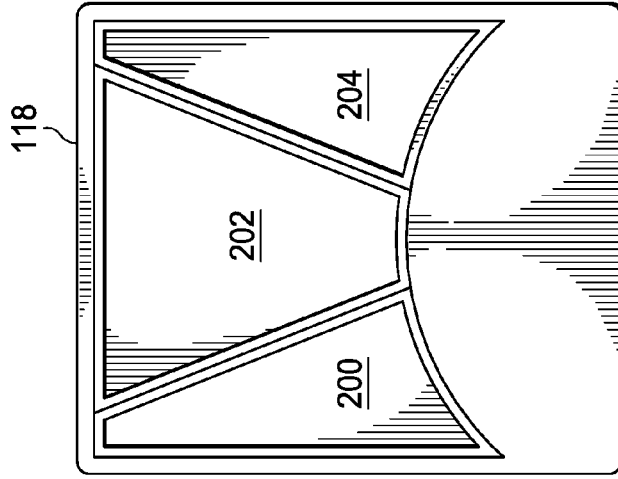

FIG. 2B

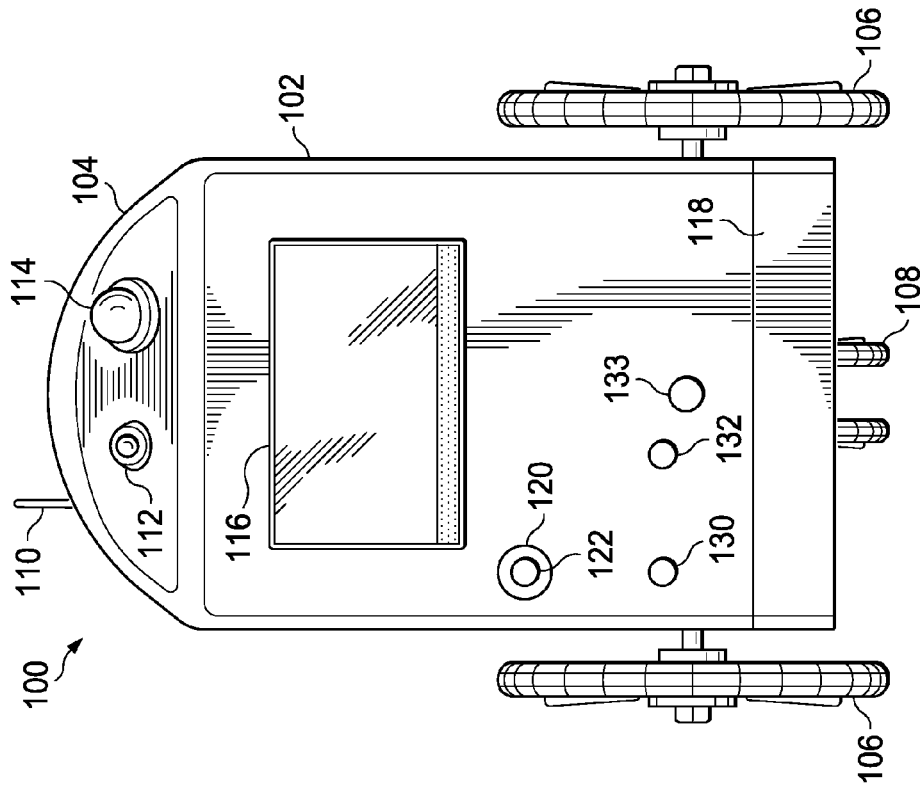

FIG. 1

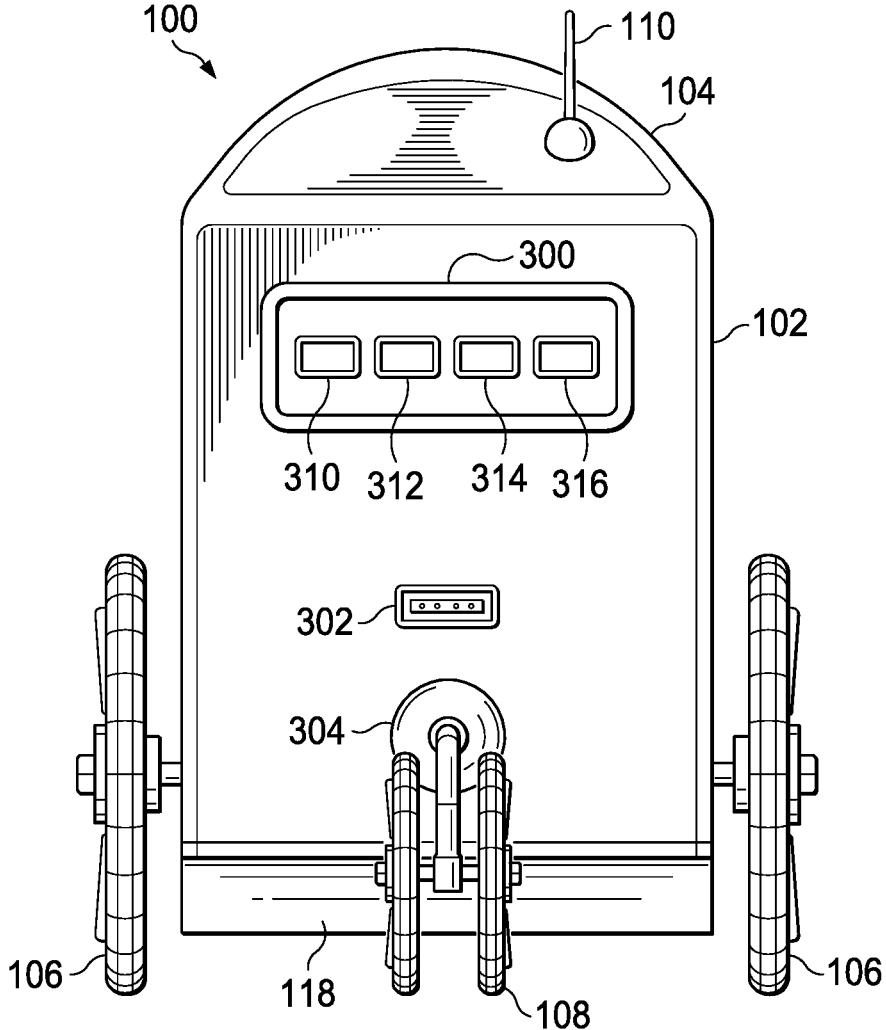
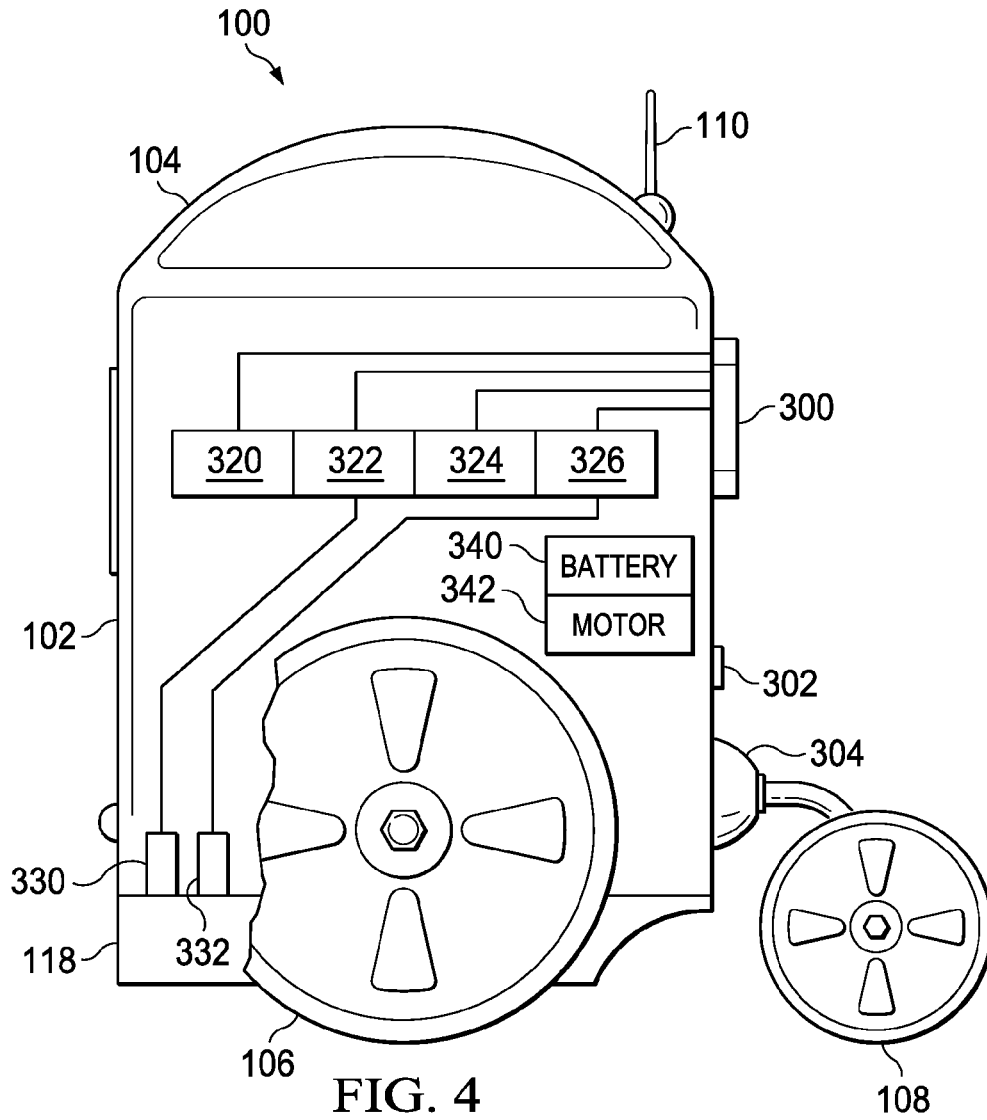

FIG. 3



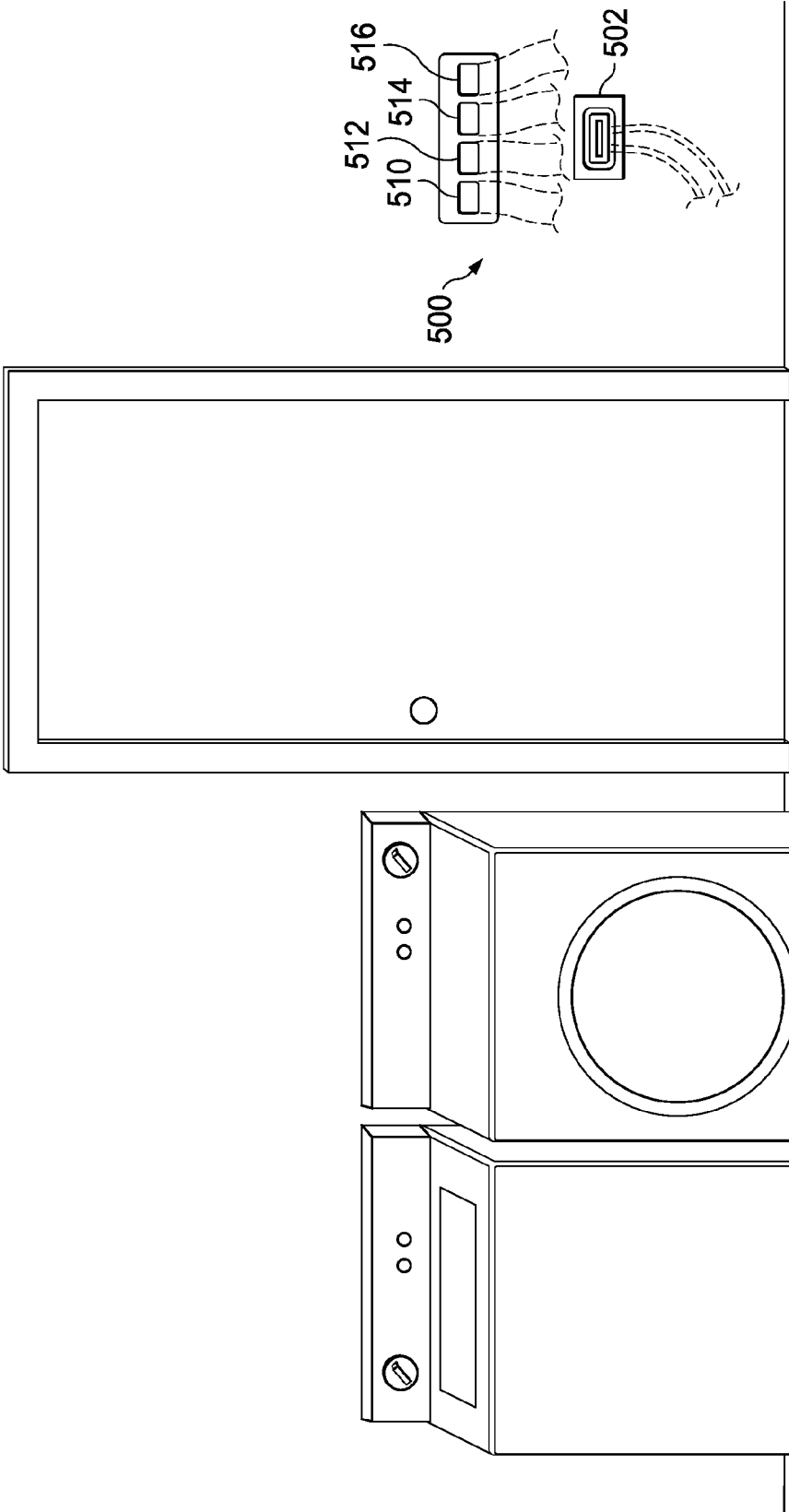

FIG. 5

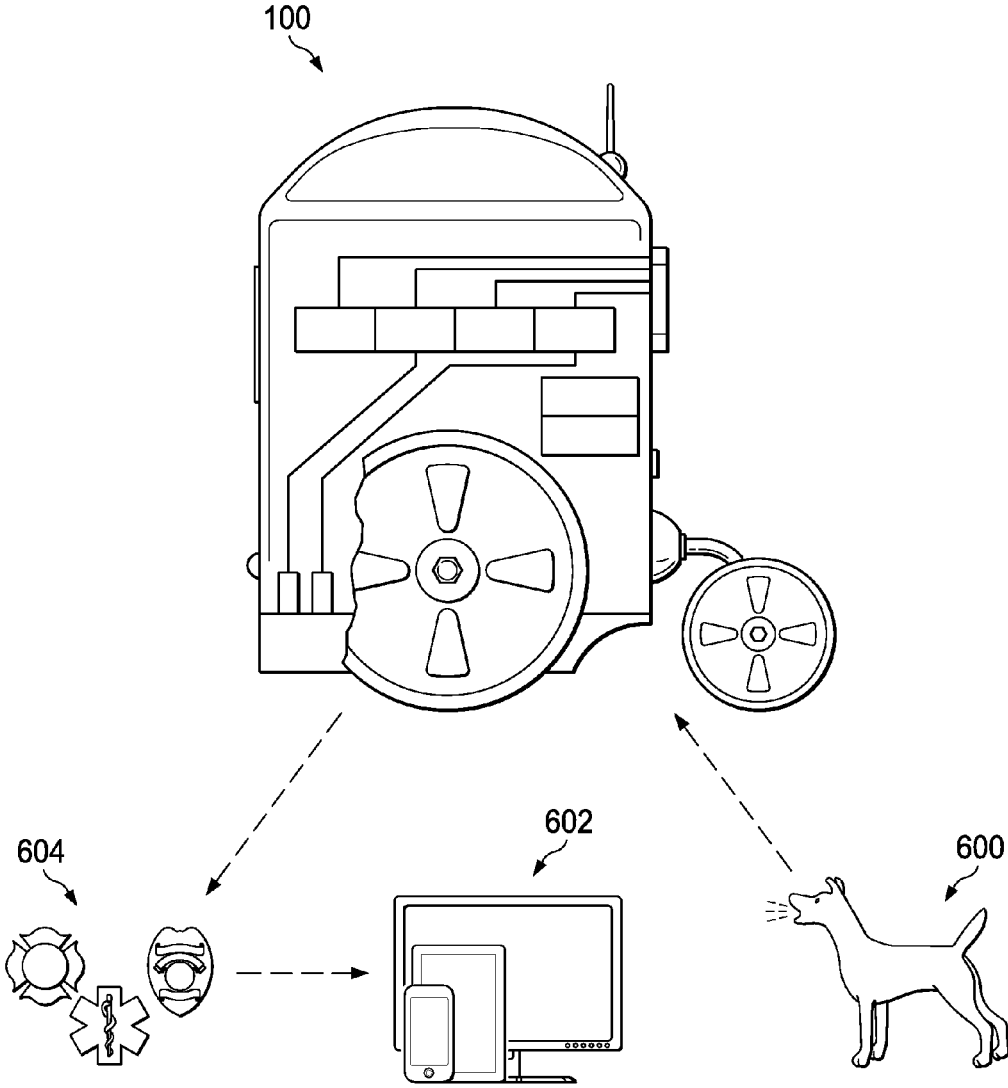

FIG. 6

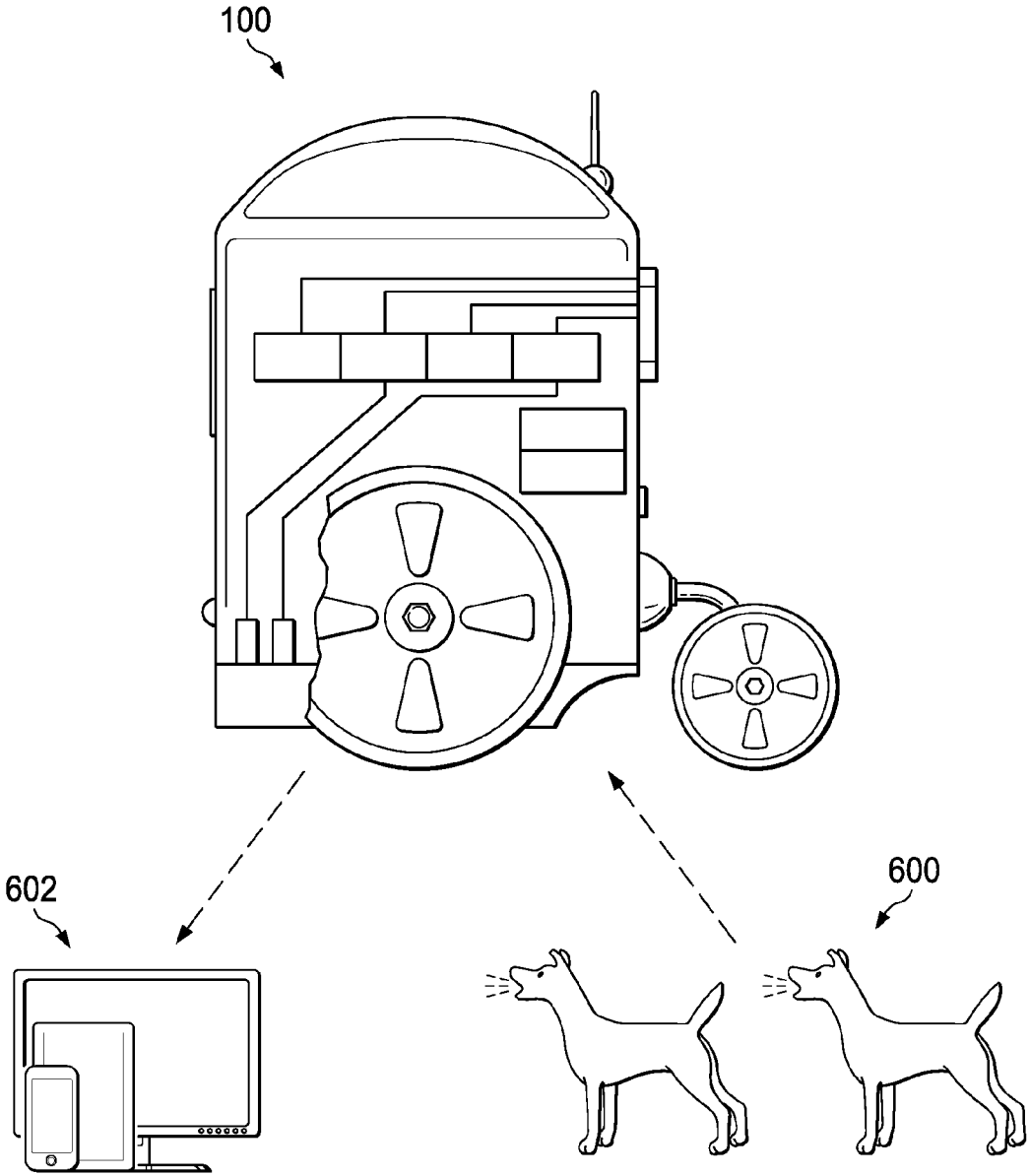

FIG. 7

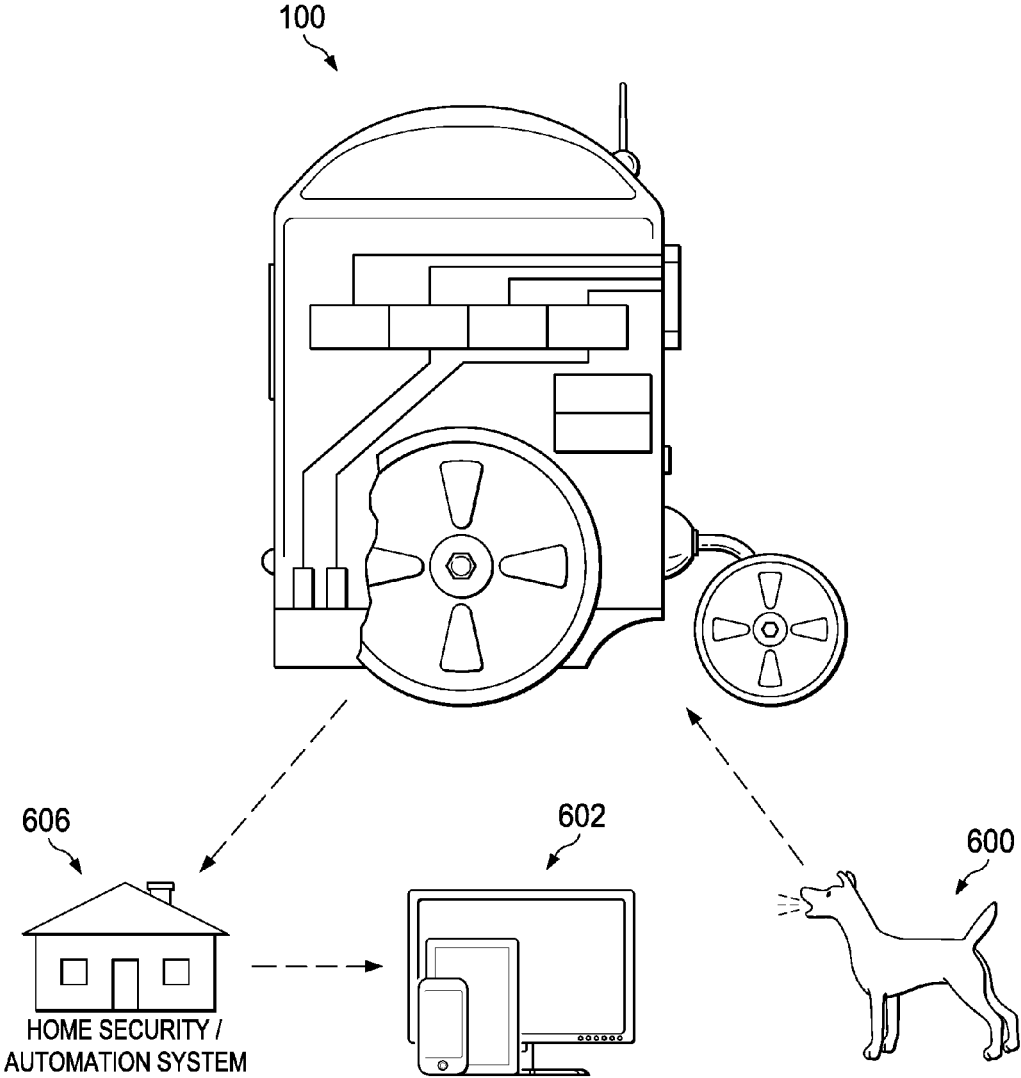

FIG. 8



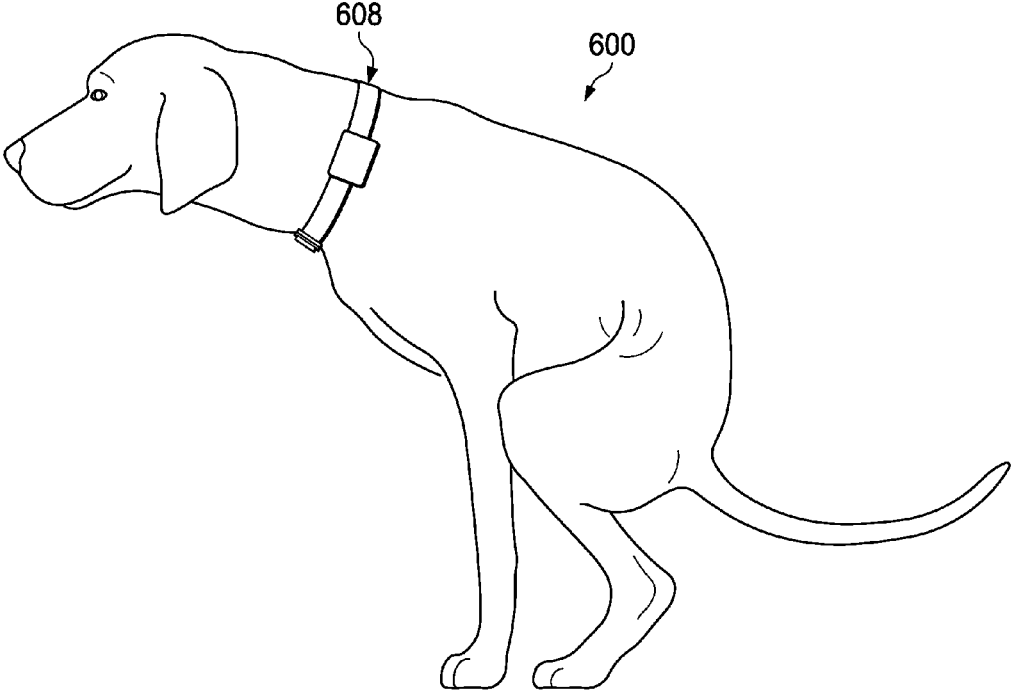

FIG. 9A

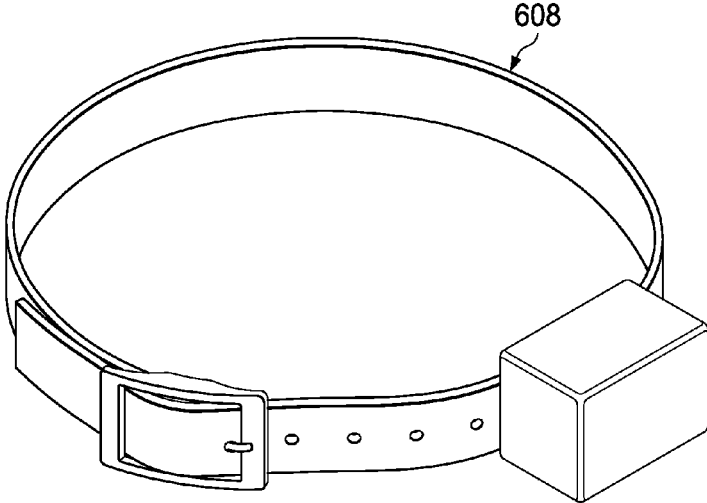

FIG. 9B

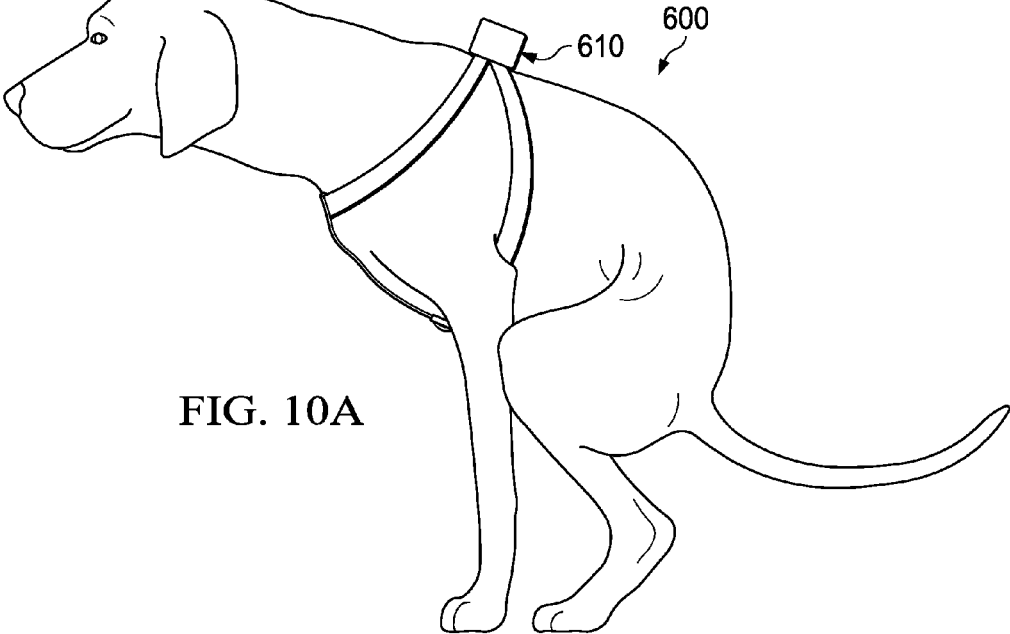

FIG. 10A

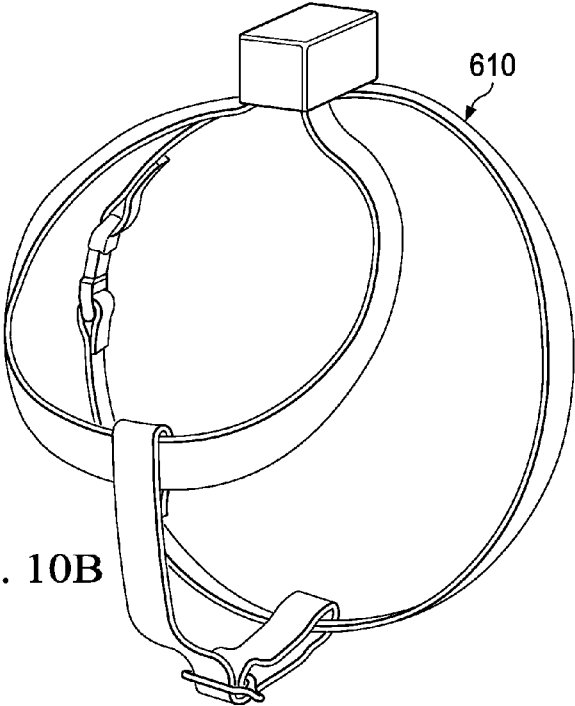

FIG. 10B

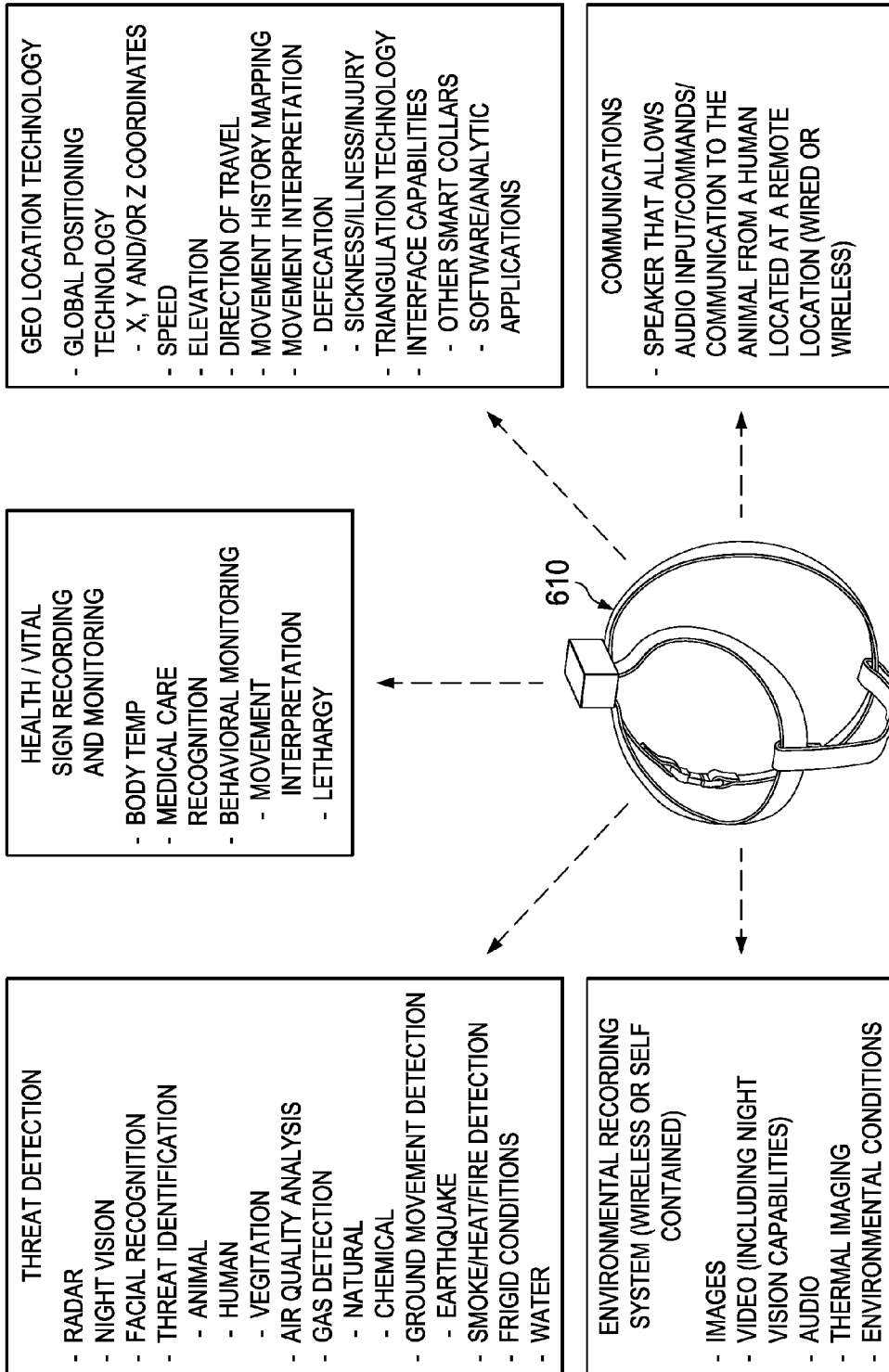

FIG. 11

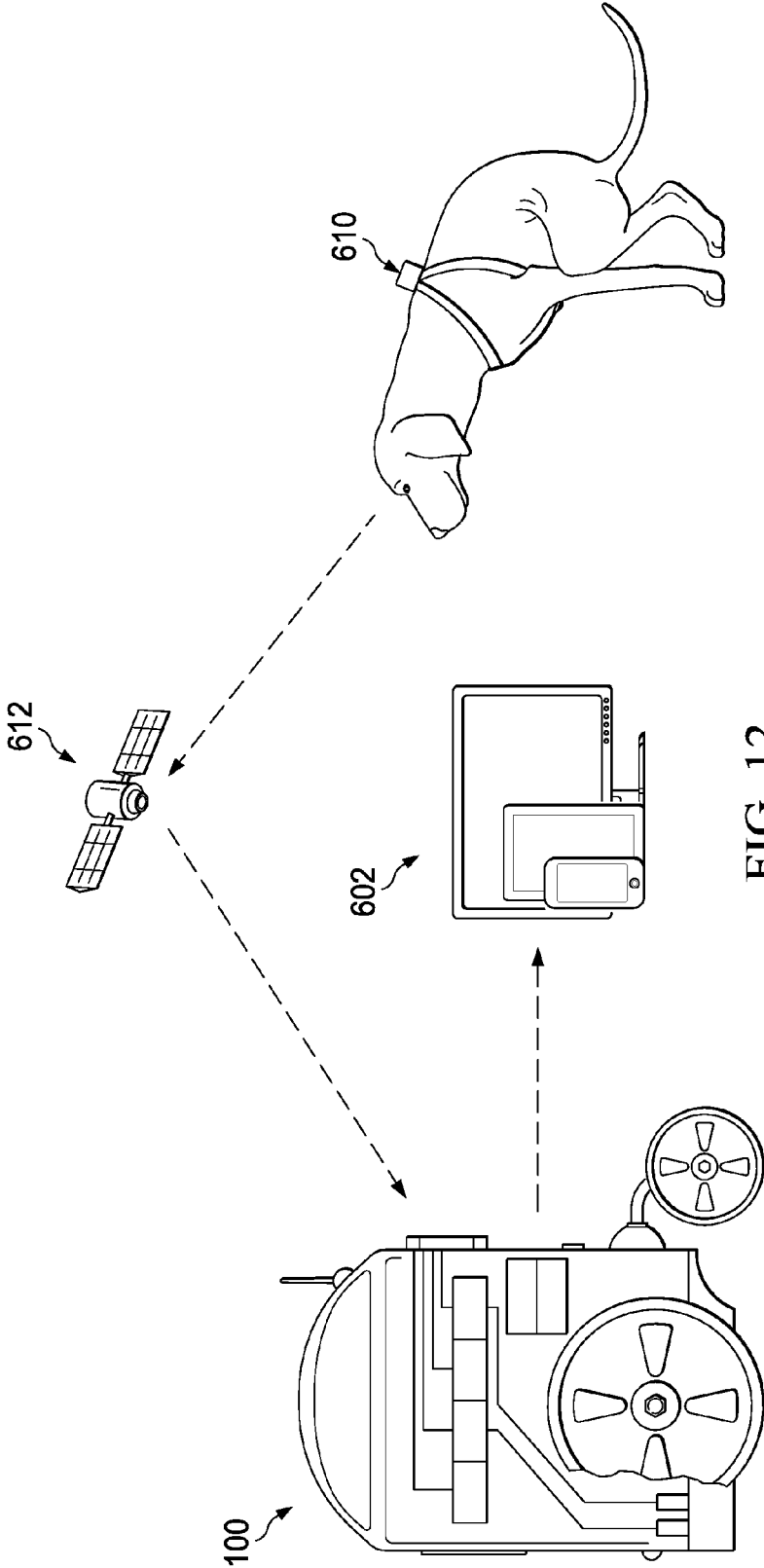

FIG. 12

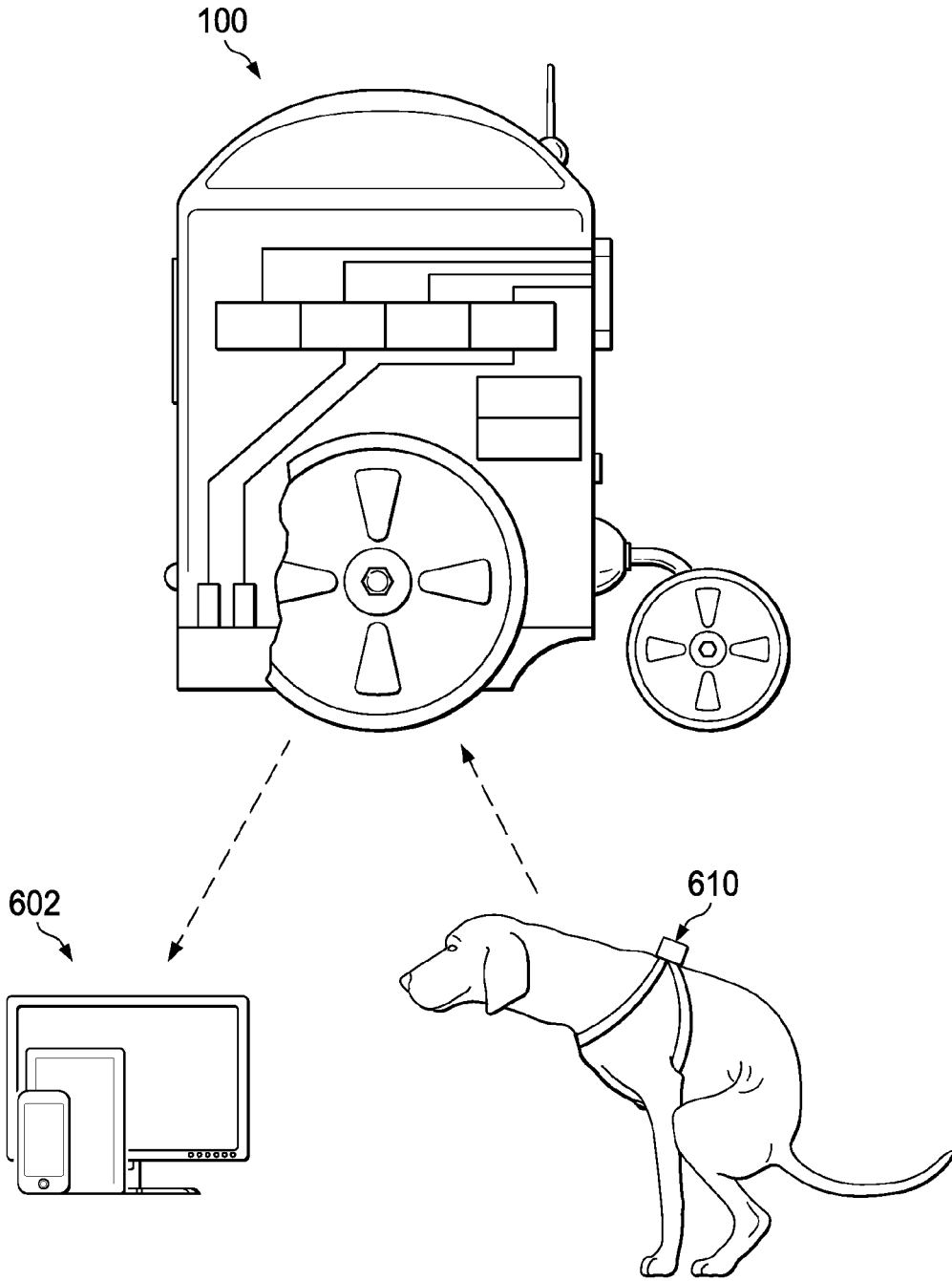

FIG. 13

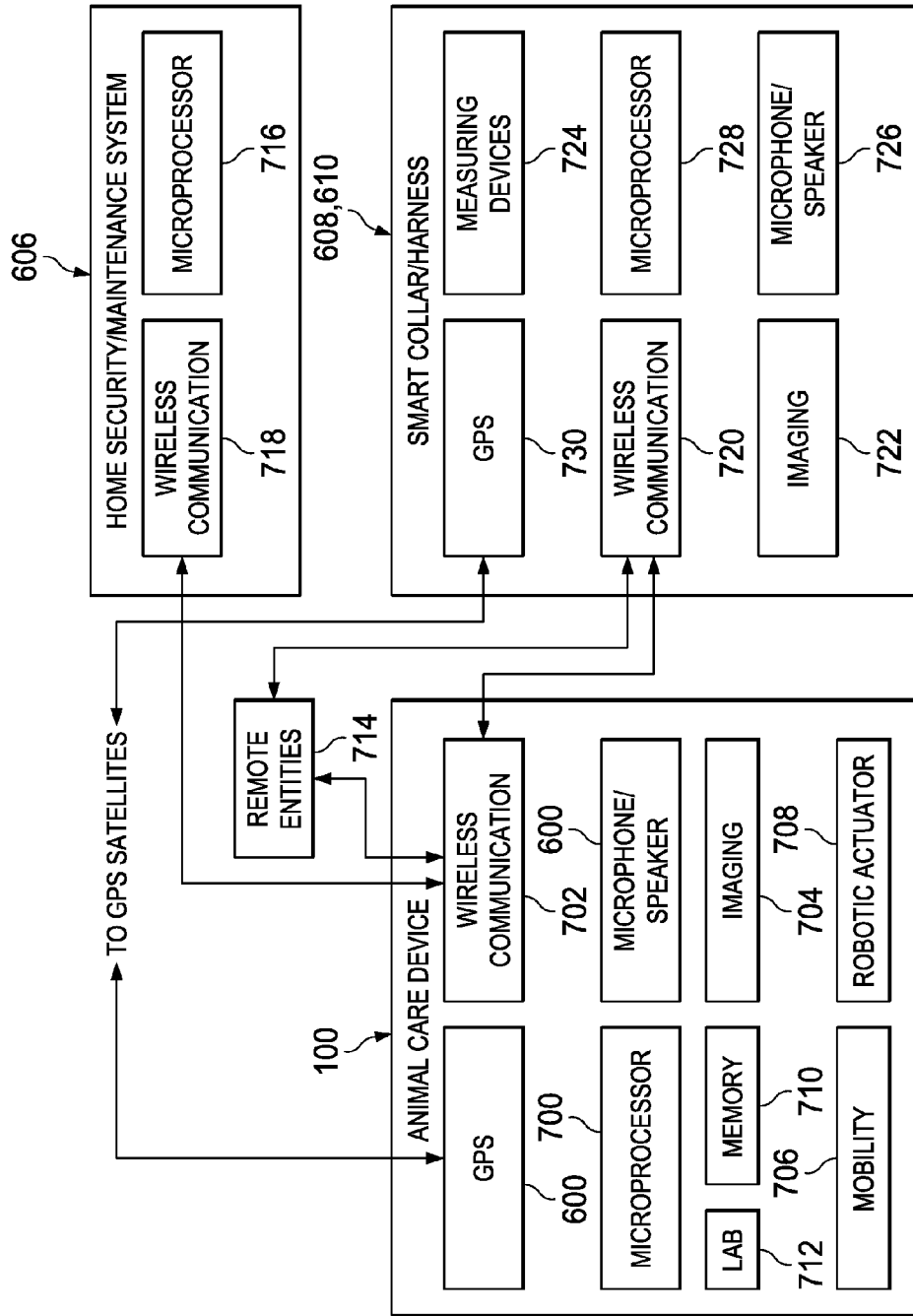

FIG. 14

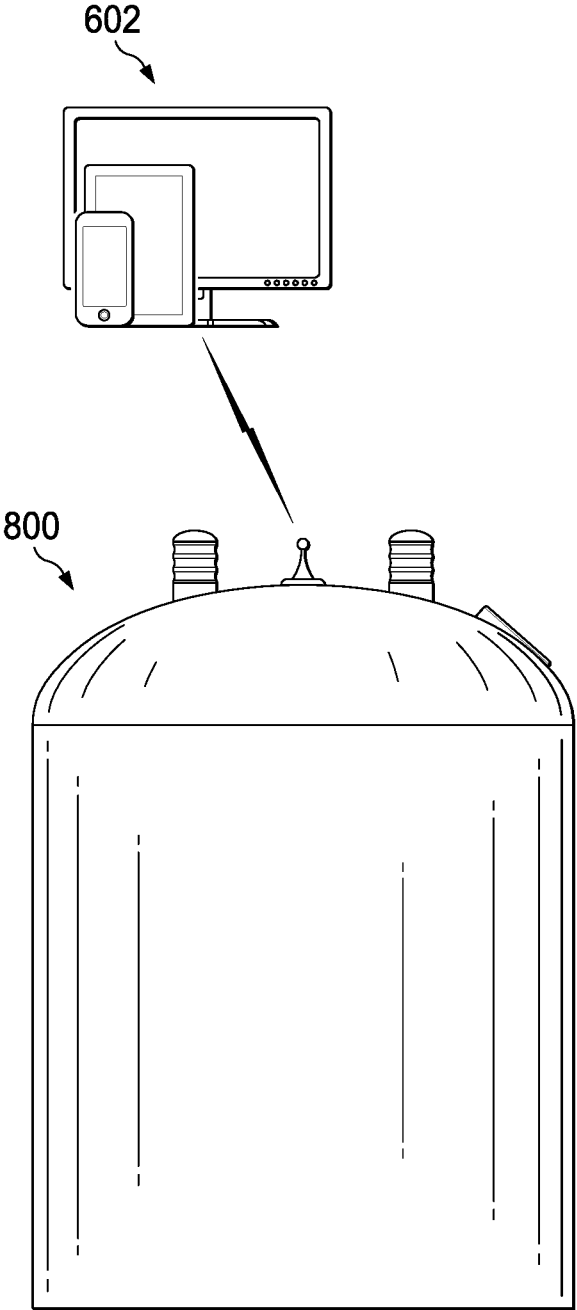

FIG. 15

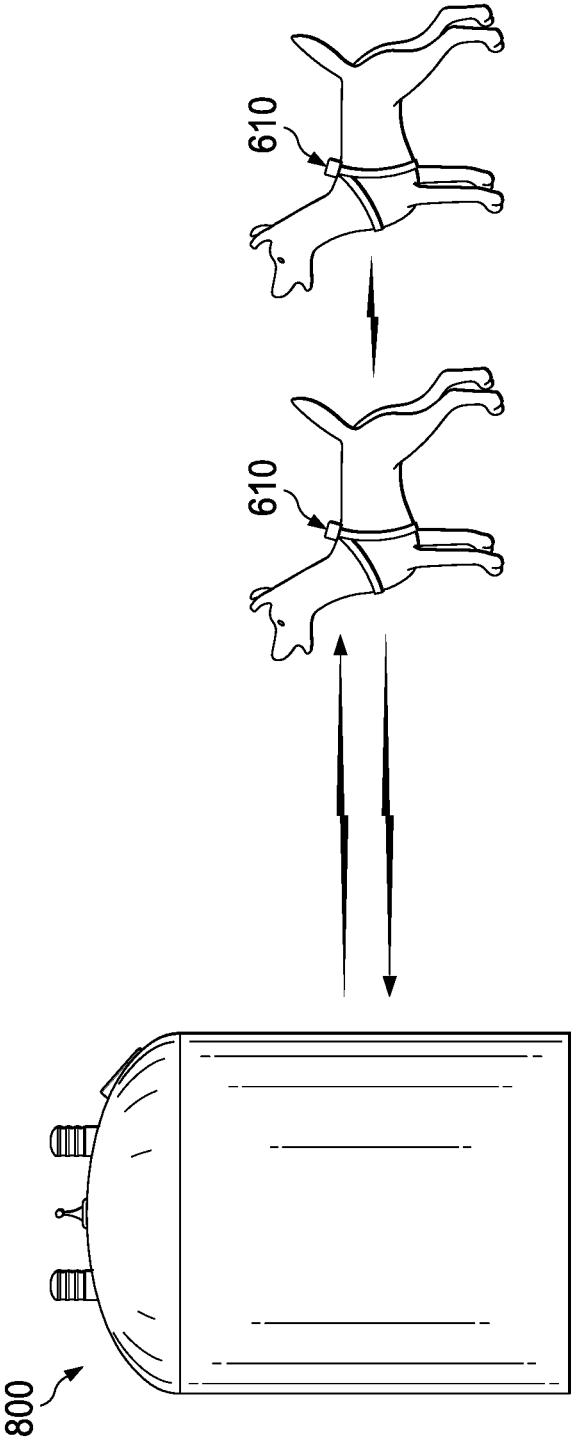

FIG. 16



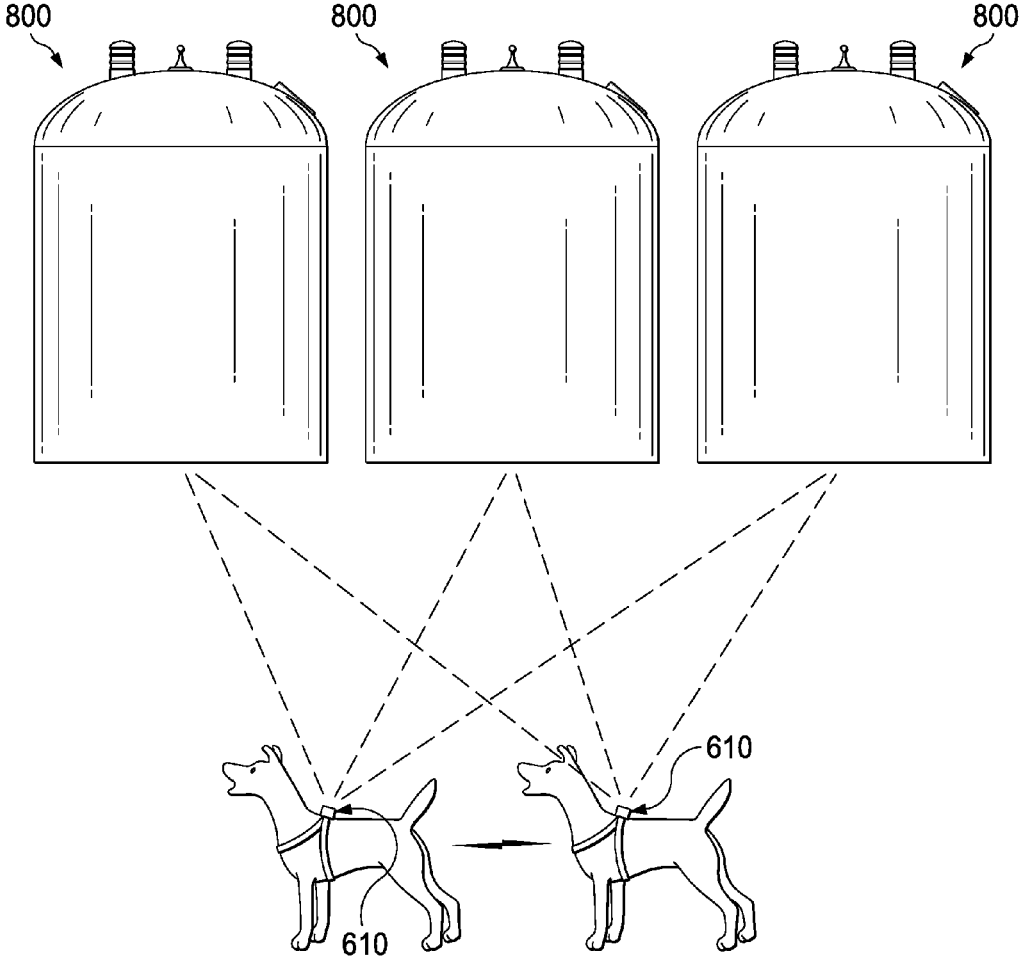

FIG. 17

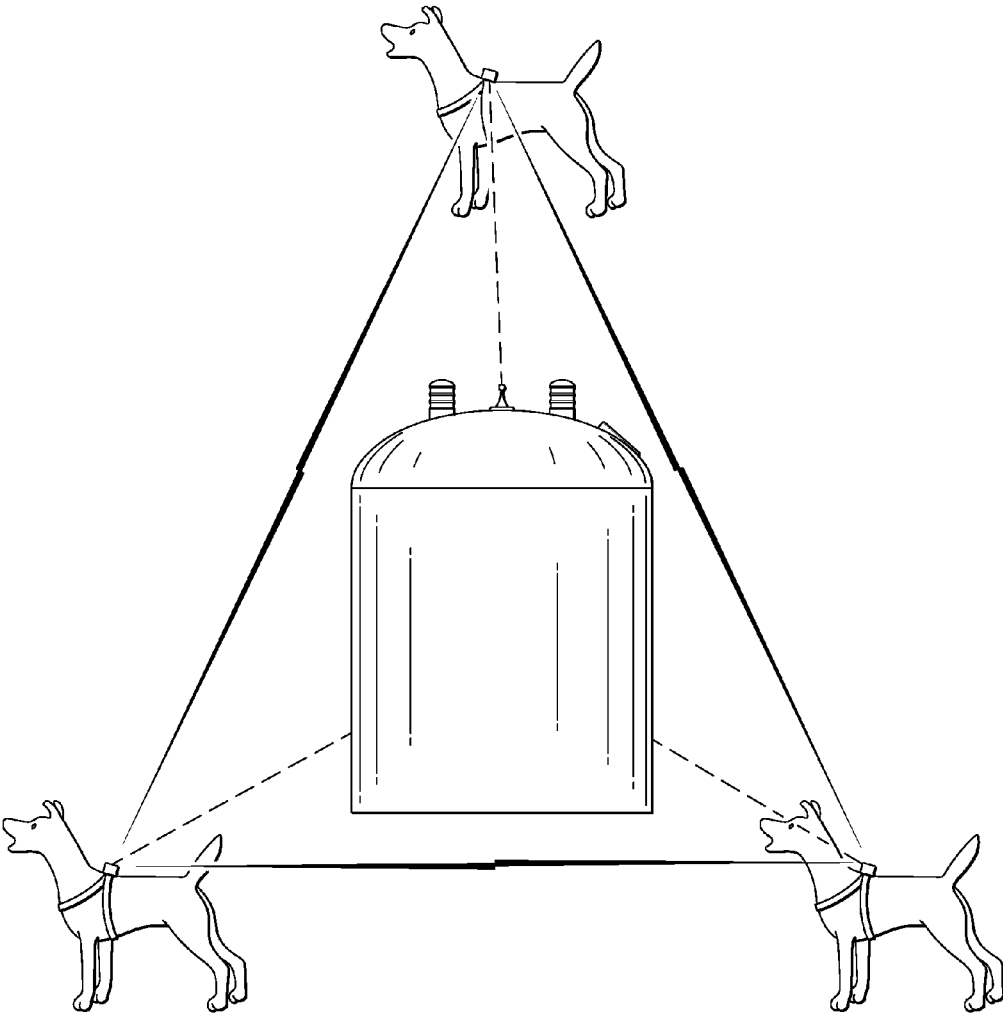

FIG. 18

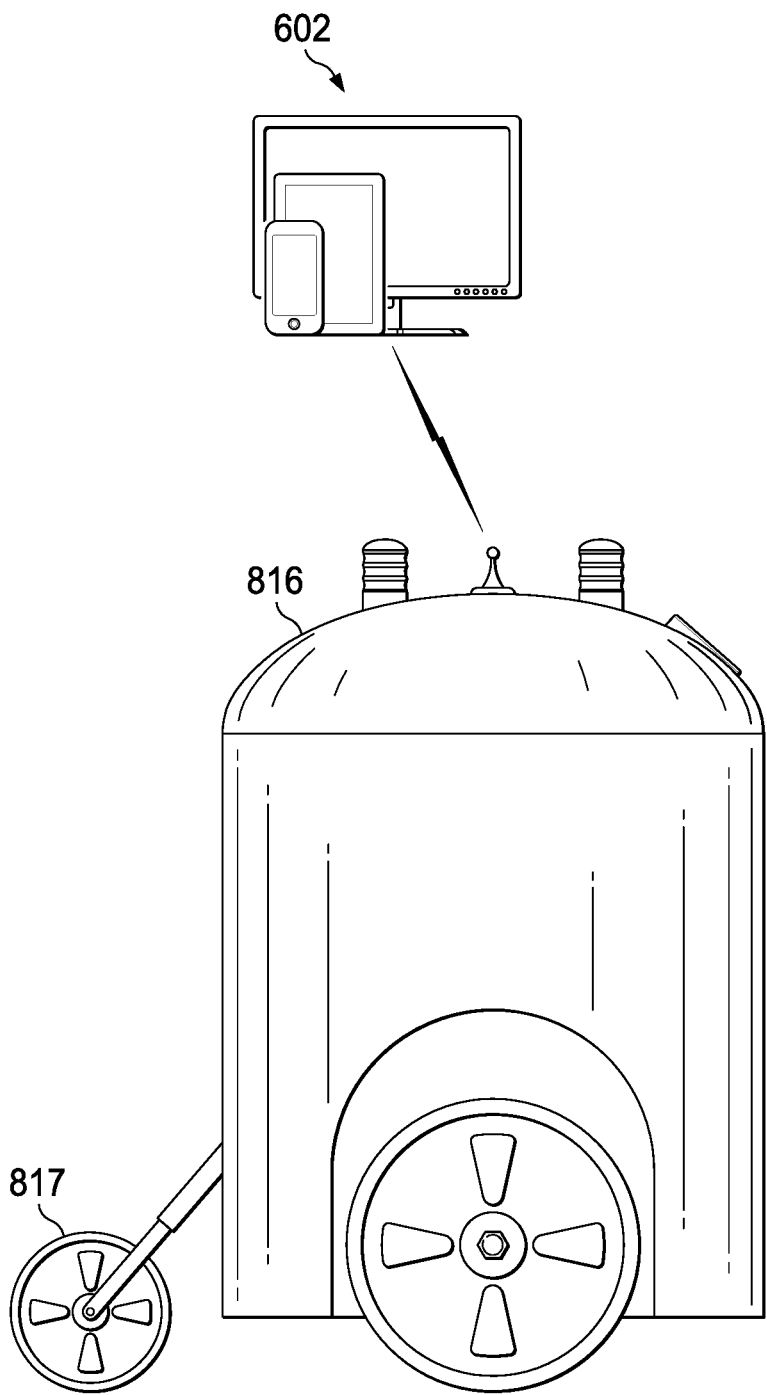

FIG. 19

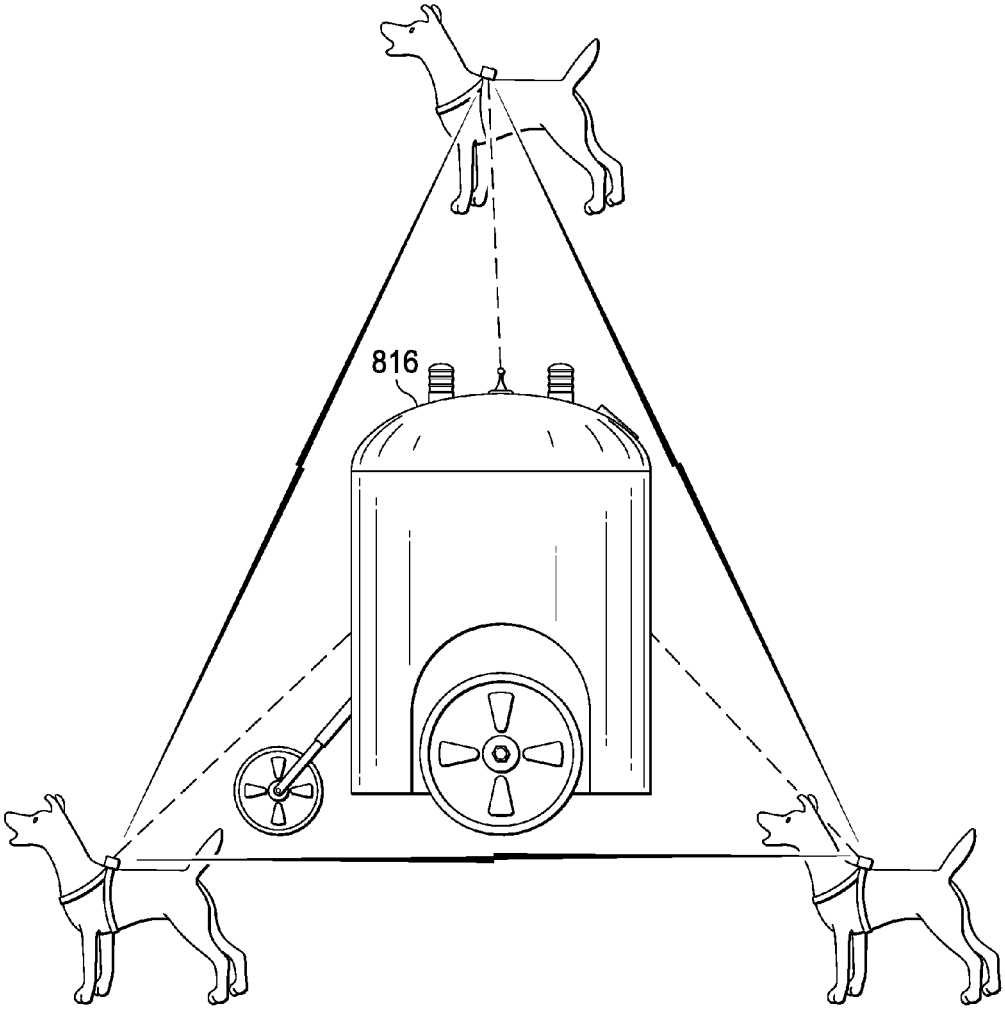

FIG. 20

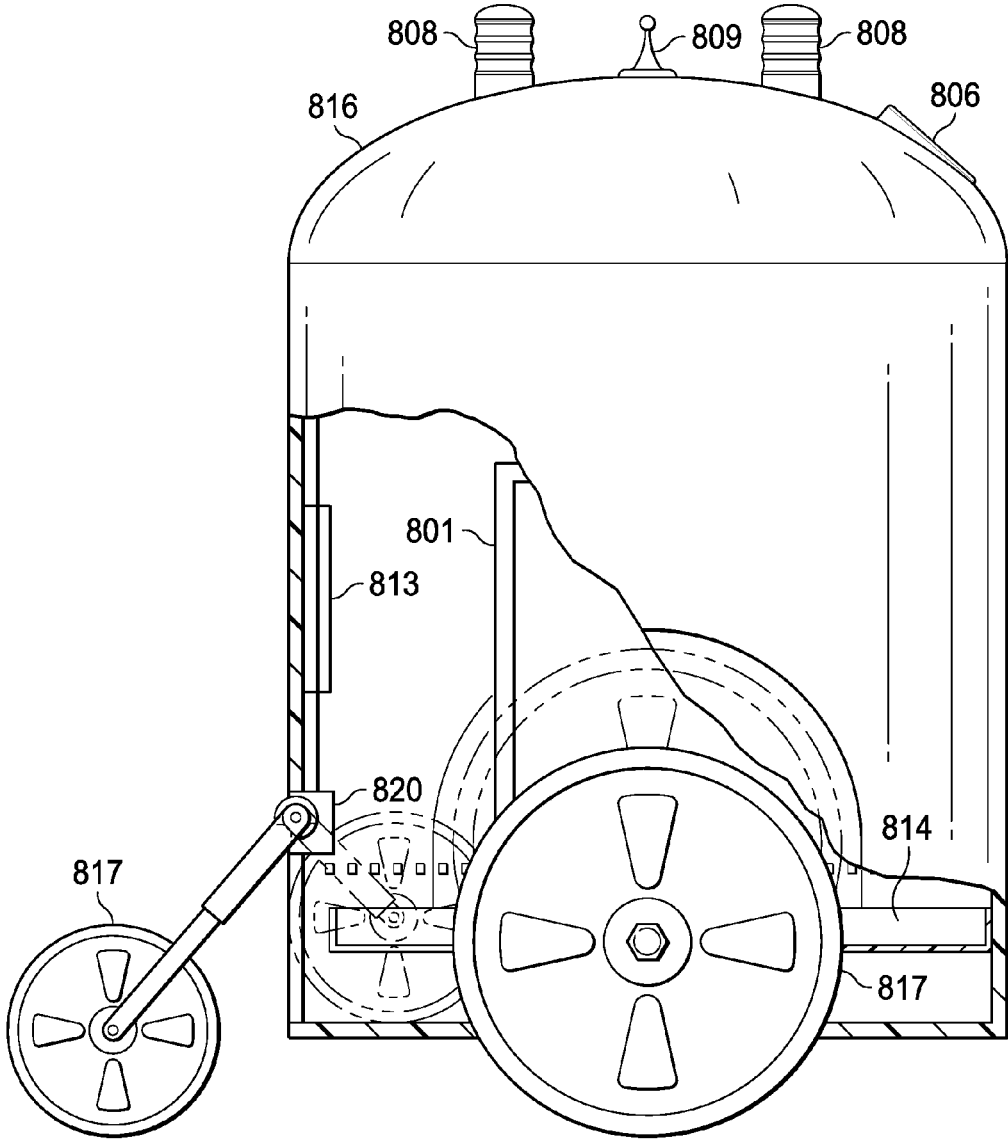

FIG. 21

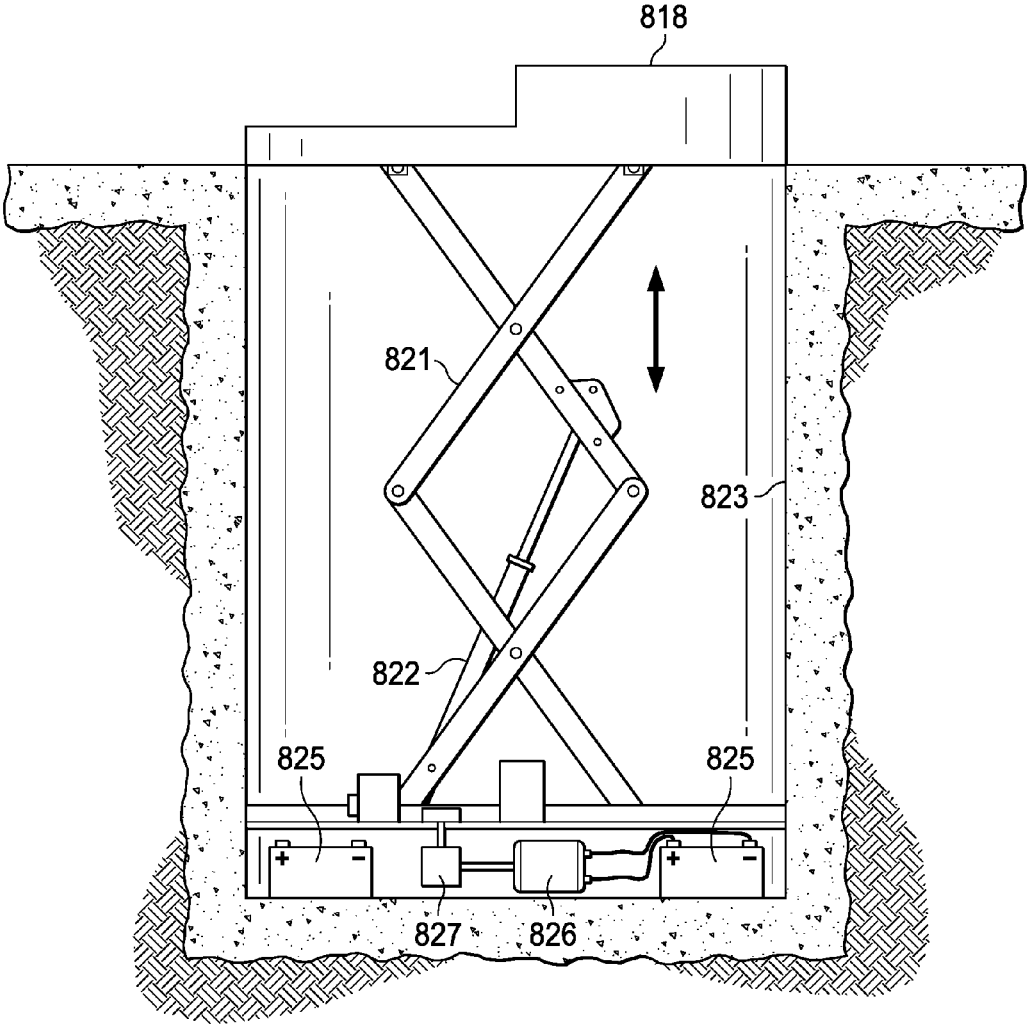

FIG. 22

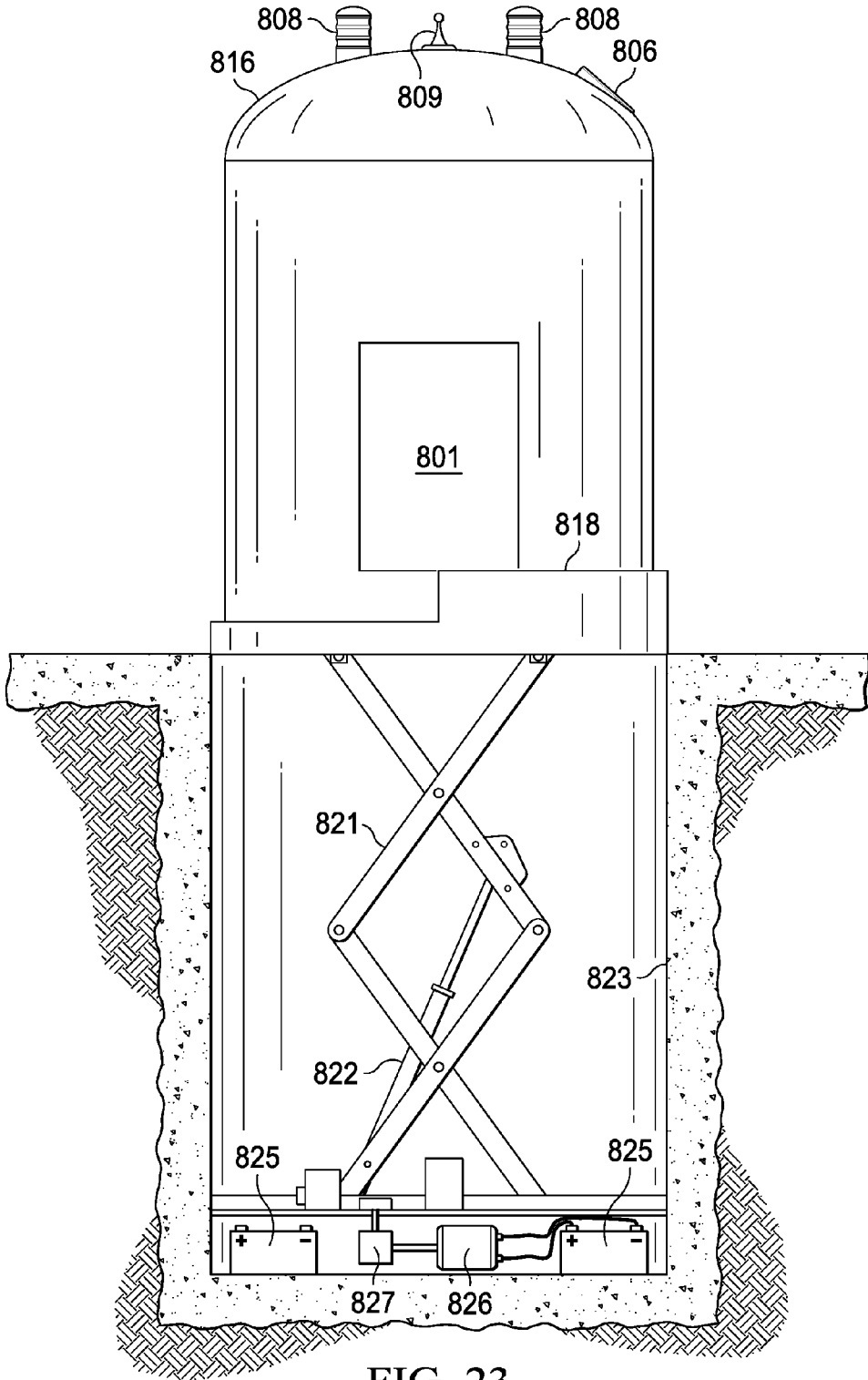

FIG. 23

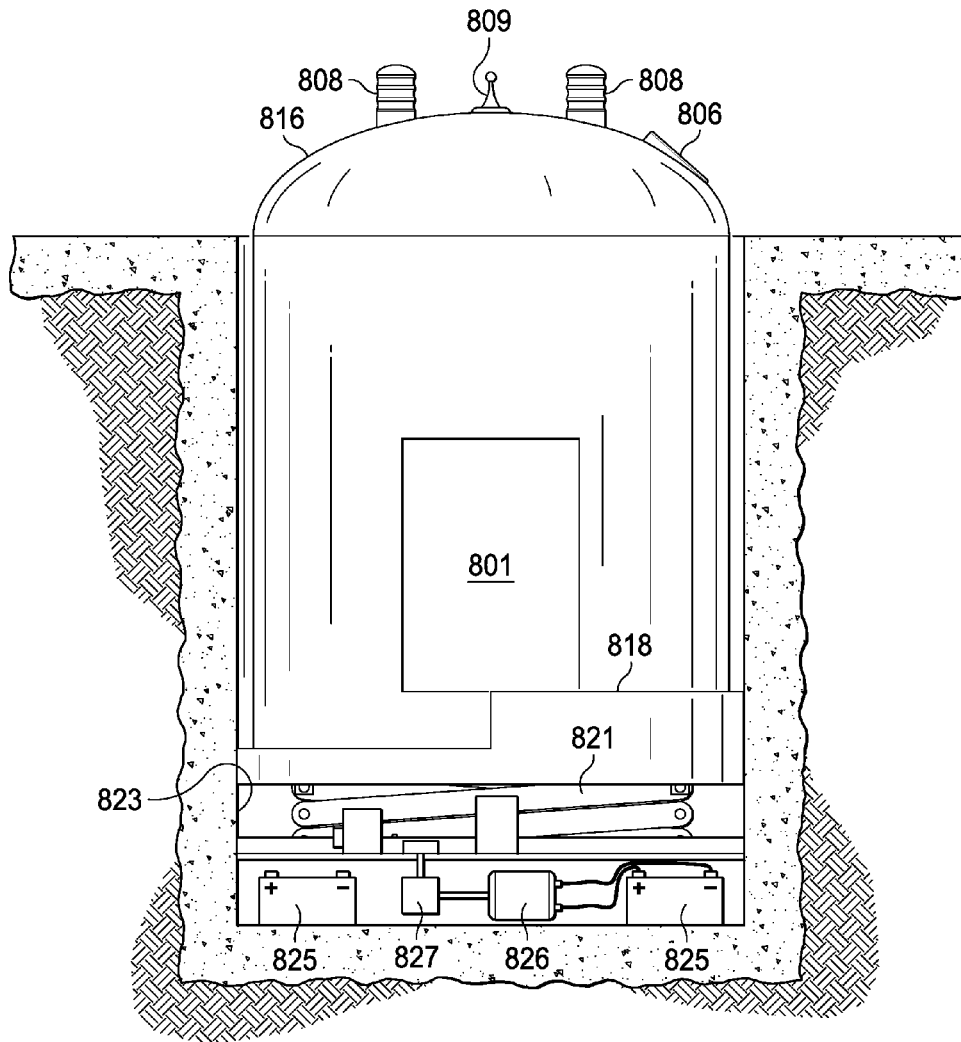
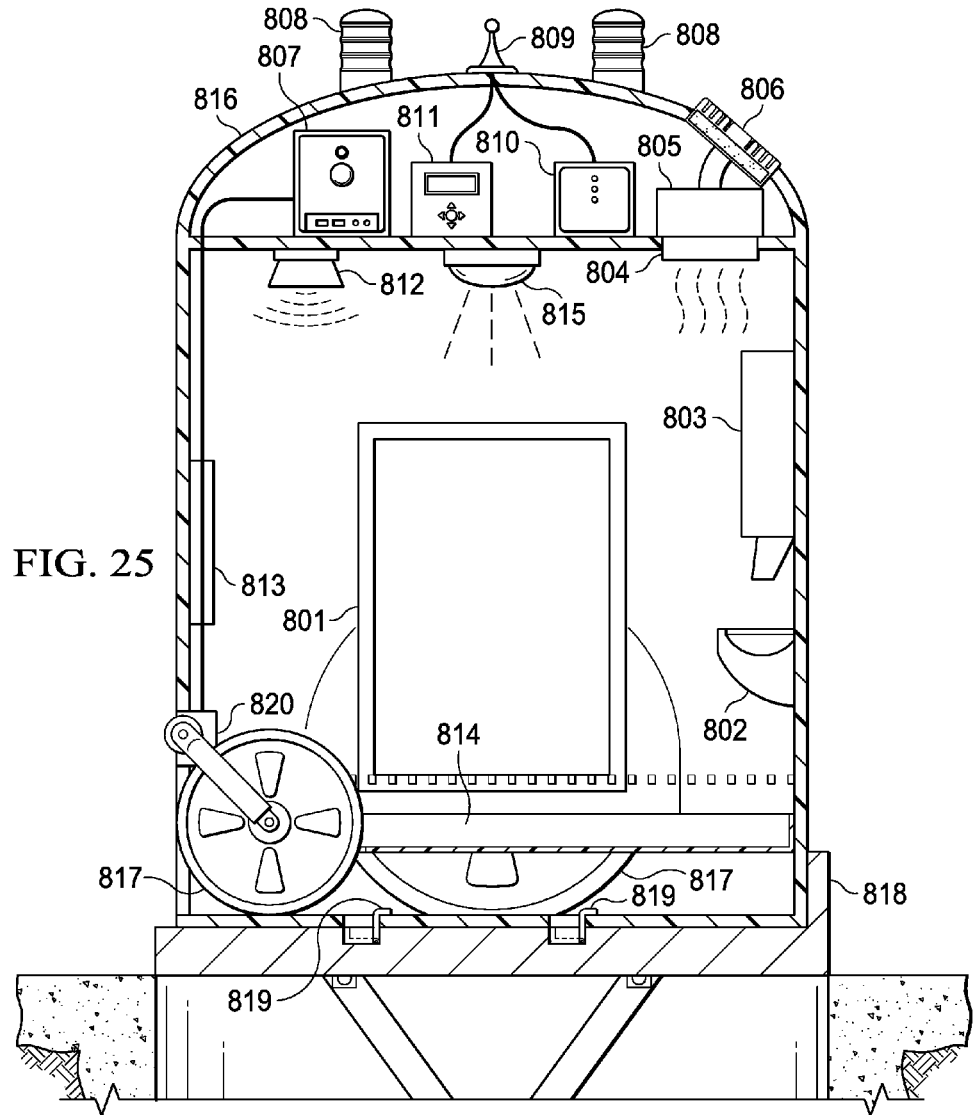

FIG. 24



- |   |  |
|---|--|
| 801 - REMOTE CONTROLLED ENTRANCE DOOR   | 811 - GPS BEACON                       |
| 802 - FOOD / WATER / MEDICINE TRAY      | 812 - TWO WAY SPEAKER                  |
| 803 - FOOD / WATER / MEDICINE DISPENSER | 813 - VIDEO SCREEN WITH TWO-WAY CAMERA |
| 804 - HEATING / COOLING VENT            | 814 - WASTE STORAGE AREA               |
| 805 - HEATING / COOLING ELEMENT         | 815 - ADJUSTABLE LIGHTING              |
| 806 - PURIFIED AIR INLET                | 816 - SAFETY POD                       |
| 807 - COMPUTER CONTROLLER               | 817 - RETRACTABLE WHEELS               |
| 808 - RESCUE STROBE                     | 818 - DOCK                             |
| 809 - COMMUNICATIONS ANTENNA            | 819 - LOCKING PINS                     |
| 810 - COMMUNICATIONS MODEM              | 820 - DRIVE MOTOR                      |



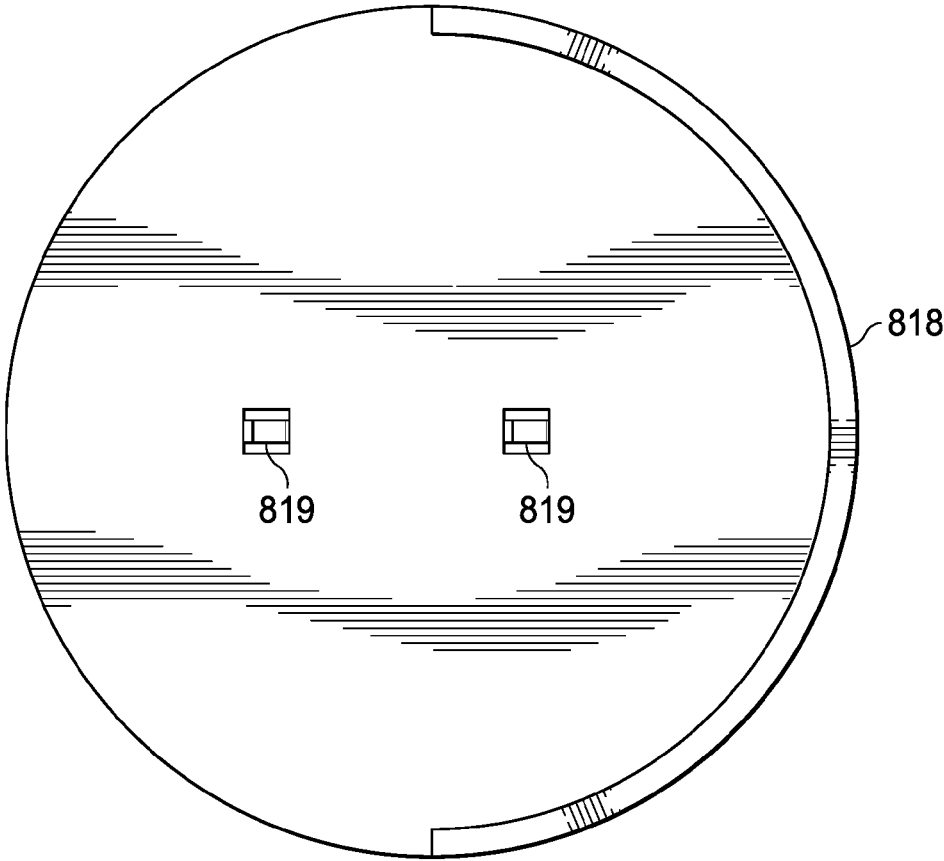

FIG. 26

## METHOD AND SYSTEM FOR REMOTE MONITORING, CARE AND MAINTENANCE OF ANIMALS

### RELATED APPLICATIONS

[0001] This patent application is a continuation-in-part application of U.S. patent application Ser. No. 14/823,859 filed on Aug. 11, 2015, which is a continuation-in-part application of U.S. patent application Ser. No. 14/191,244 filed on Feb. 26, 2014 (now U.S. Pat. No. 9,131,660), which is a continuation of U.S. patent application Ser. No. 13/892,292 filed 12 May 2013 (now U.S. Pat. No. 8,707,900), which claims the benefit of U.S. Provisional Patent Application No. 61/848,437 filed Jan. 4, 2013, and U.S. Provisional Patent Application No. 61/702,856 filed Sep. 19, 2012. All aforementioned patent applications are incorporated therein by reference.

### TECHNICAL FIELD

[0002] The invention relates generally to mechanical systems and, more particularly, the invention relates to a remote controlled personal animal care device.

### DESCRIPTION OF THE RELATED ART

[0003] As computers have grown increasingly important in today's society, humans have created animal care devices to automate and enhance various activities that have traditionally been performed manually. Domesticated pets, livestock animals and wild animals maintained in a controlled environment rely in great measure on the care and attention of humans to remain mentally and physically healthy and alert. Items that are assistive in nature to help owners maintain the wellbeing of their animals can provide some portion of such care and attention. Animal owners are often hampered in their attempts to properly care for their animals when the owner is required to be geographically distant from the place their animals are kept. In many cases, animal owners are required to contract with third-party providers to perform simple tasks related to feeding, watering and administering medications to animals when the animal owner is not physically present to do so. Indeed, each year, numerous animals die or are caused physical or emotional harm due to the lack of proper care by owners who are geographically removed from the animal or due to the inadvertent or purposeful oversight of third-party animal caregivers.

### SUMMARY

[0004] An animal care system for remote care and maintenance of animals is presented. According to one embodiment of the present disclosure, the system includes a housing and a mobility portion coupled to the housing and operable to move the housing. The system further includes a wireless data communications system disposed with the housing and wirelessly communicatively coupled with an external data communications system and an electronic data processor disposed within the system and controlling the mobility portion. In addition, the system includes food, water and medicine storage portions disposed within the housing. Further, the system includes a removable tray coupled to the housing and disposed proximate to a lower portion of the housing, the tray having a food tray portion operable to receive food from the food storage portion, a water tray

portion operable to receive water from the water storage portion and a medicine tray portion operable to receive medicine from the medicine storage portion and a docking portion fixedly coupled to the housing and disposed generally on a rear portion of the housing, and connectively coupled to the food, water and medicine storage portions. Also, the system includes an internal electronic fence transceiver in wireless communication with an external electronic fence transceiver, the internal electronic fence transceiver disposed generally within the housing and the external electronic fence transceiver disposed externally and remote from the housing, wherein the internal electronic fence transceiver activates the external electronic fence transceiver when the external electronic fence transceiver is at least a predetermined distance from the housing.

### BRIEF DESCRIPTION OF THE DRAWINGS

[0005] A better understanding of the claimed subject matter can be obtained when the following detailed description of the disclosed embodiments is considered in conjunction with the following figures.

[0006] FIG. 1 is a diagram illustrating a front view of an animal care device 100 according to one embodiment of the present disclosure;

[0007] FIG. 2A is a side view of tray 118 according to one embodiment of device 100 according to one embodiment of the present disclosure;

[0008] FIG. 2B is a top view of tray 118 according to one embodiment of device 100 according to one embodiment of the present disclosure;

[0009] FIG. 3 is a rear view of device 100 according to one embodiment of the present disclosure;

[0010] FIG. 4 is a side view of device 100 according to one embodiment of the present disclosure;

[0011] FIG. 5 is a block diagram of a docking station 500 for device 100 according to one embodiment of the present disclosure;

[0012] FIGS. 6-8 are diagrams illustrating information flows in exemplary embodiments of an animal care device 100 according to the teachings of the present disclosure;

[0013] FIGS. 9A and 9B are illustrations of an exemplary embodiment of a smart collar 608 and a dog wearing the smart collar 608 according to the teachings of the present disclosure;

[0014] FIGS. 10A and 10B are illustrations of an exemplary embodiment of a smart collar and a dog wearing the smart collar 608 according to the teachings of the present disclosure;

[0015] FIG. 11 is a diagram illustrating a variety of applications for a smart collar 608 according to the teachings of the present disclosure;

[0016] FIGS. 12 and 13 are diagrams illustrating information flows in exemplary embodiments of an animal care device 100 operating cooperatively with a smart collar 608 according to the teachings of the present disclosure;

[0017] FIG. 14 is a simplified block diagram of an exemplary embodiment of an animal care device 100 in operation with a smart collar 608/smart harness 610 according to the teachings of the present disclosure;

[0018] FIG. 15 is a simplified diagram of another exemplary embodiment of an animal care device 800 in operation with a plurality of user computing devices 602 according to the teachings of the present disclosure;

[0019] FIG. 16 is a simplified diagram of an exemplary embodiment of an animal care device 800 in operation with a plurality of smart collars/harnesses according to the teachings of the present disclosure;

[0020] FIGS. 17 and 18 are simplified diagrams of an exemplary embodiment of a plurality of animal care device 800 in operation with a plurality of smart collars/harnesses according to the teachings of the present disclosure;

[0021] FIG. 19 is a simplified diagram of an exemplary embodiment of a mobile animal care device 816 in operation with a plurality of user computing devices 602 according to the teachings of the present disclosure;

[0022] FIG. 20 is a simplified diagram of an exemplary embodiment of a mobile animal care device 816 in operation with a plurality of smart collars/harnesses according to the teachings of the present disclosure;

[0023] FIG. 21 is a partial cross-sectional side view of an exemplary embodiment of a mobile animal care device 816 according to the teachings of the present disclosure;

[0024] FIGS. 22-24 are cross-sectional side views of an exemplary embodiment of an animal care device 816 with an anchoring and elevation mechanism according to the teachings of the present disclosure;

[0025] FIG. 25 is a more detailed cross-sectional side view of an exemplary embodiment of a mobile animal care device 816 with an elevation mechanism according to the teachings of the present disclosure; and

[0026] FIG. 26 is a top view of an exemplary embodiment of the locking pins 819 according to the teachings of the present disclosure.

#### DESCRIPTION

[0027] Humans have been making use of animals for both productive purposes, such as food and labor, and as companions, such as domesticated dogs and cats, since the earliest days of recorded history. In order to make use of these animals, the animals are typically kept in controlled or semi-controlled environments, such as houses and fenced outdoor areas, in order to control the movements of the animals and to protect the animals from predators. As a result of placing the animals in such environments, the animal must rely upon human assistance and support in order to survive. For example, domestic dogs and cats rely upon their owners to provide food and water. In addition, humans often train the animals to behave in certain ways that require human assistance or support as the animals may be physically incapable of performing such actions directly. For example, a door may need to be opened for a dog to allow the dog to relieve itself outside and a cat litter box requires periodic cleaning by the owner. However, the time available to an owner to perform these activities may be limited or the owner may need to be in a physically distant location from the animal due to, for example, job responsibilities. A pet care robot may be used to perform various animal care tasks that normally are performed by humans. For example, a pet care robot may be capable of walking and playing with a domestic dog that lives in a residence, and providing food, water and medicine to the dog. In addition, the pet care robot may provide a video and audio link to allow the dog to see the dog's owner, even though the owner is physically distant from the dog.

[0028] FIG. 1 is a diagram illustrating a front view of an animal care device 100 according to one embodiment of the present disclosure. The animal care device 100, in various

embodiments, provides various capabilities useful for providing care to an animal. For example, the animal care device 100 may walk a dog, provide food, water and medicine, or provide a video display showing a real-time or prerecorded video or image of the dog's owner. The animal care device 100 comprises a main body 102, an upper body 104, a pair of front wheels 106, a pair of rear wheels 108, a wireless system 110, a camera 112, a playing device 114, audio/video display 116, a tray 118, an arm 120, a scent emitter 130, a heat/cold emitter 132, and a secondary animal waste detection sensor system 133.

[0029] Main body 102 comprises the main physical support structure for the animal care device 100. In the disclosed embodiment, main body 102 is generally cylindrical in shape and provides mounting support for front wheels 106, rear wheels 108, tray 118 and display 116. Enclosed within main body 102 may be various electronic, electro-mechanical and mechanical systems for operation of animal care device 100 as described in greater detail below. Main body 102 may be formed from any suitable material, such as steel, aluminum, plastic or other composites as desired. For example, an animal care device 100 for use with a horse may require use of stronger, heavier or more costly materials than one for use with domesticated house pets. Main body 102 may alternatively be of other suitable shapes. Front wheels 106 are coupled to main body 102 and may be used to move and/or steer animal care device 100. Rear wheels 108 are coupled to main body 102 and may alternatively or in addition to front wheels 106 to move and/or steer animal care device 100. The illustration of the pair of front wheels 106 and rear wheels 108 represent only a single embodiment of device 100, alternatively, various other drive systems may be used in various suitable combinations for the use of device 100. For example, a single rear wheel 108 may be used and rear and front wheels 108 and 106 may be combined or organized in some other suitable format, such as four wheels with a steering system similar to a passenger vehicle. Also, device 100 may be a tracked vehicle for operation outdoors or in hostile environments, such as snow. Device 100 may further comprise electronic data processing capabilities, such as using a central processing unit (CPU) coupled to memory (not shown), in order to store and execute computer programming instructions to control device 100.

[0030] In one embodiment, upper body 104 comprises a generally dome shaped element removably or fixably coupled to main body 102. More specifically, upper body 104 and main body 102 may be formed as a single physical element or may represent separate physical elements that are coupled together. For example, upper body 104 may be designed to be removed from main body 102 to allow access to the interior of main body 102 for maintenance purposes. Upper body 104 may also be of other suitable shapes in various embodiments. Upper body 104 provides support and mounting locations for wireless system 110, camera 112 and toy 114. Enclosed within upper body 104 may be electrical, electro-mechanical and/or mechanical elements in support of device 100 as described in greater detail below. For example, portions of wireless system 110 may be disposed within the interior of upper body 104. Upper body 104 may further be operable to rotate around a vertical axis independently of main body 102, for example, to allow camera 112 to be pointed in various directions without rotating main body 102 as well. In general, similar to main body 102,

upper body **104** may be of a suitable shape and be made of suitable materials for a particular embodiment of device **100**.

[0031] Wireless system **110** comprises one or more of a global positioning system (GPS) transmitter/receiver, a wireless audio and/or data communications transmitter/receiver, such as an IEEE 802.11a/b/g/n or cellular data connection, Bluetooth transmitter/receiver, and a wireless fence system and suitable associated hardware, such as an antenna.

[0032] Camera **112** comprises any suitable still and/or video camera for generating an image and communicating the image to the wireless system **110**.

[0033] Toy **114** comprises a ball at the end of cord that is operable to be ejected away from device **100** and retracted back to device **100**. For example, a rubber ball may be used that is thrown for a dog to chase so that an owner can play with their dog from a remote location. Alternatively, toy **114** may comprise an imitation mouse that may be used to entertain a cat. In general, toy **114** may comprise any suitable object that is tethered to device **100** and ejected away from, and returned to, device **100** for interaction with an animal. Alternatively, toy **114** may be any form of device that can amuse the animal, such as a light or laser.

[0034] Tray **118** comprises a tray that is detachable from and re-attachable to device **100** in order to serve food, water and/or medicines to an animal. In one embodiment, device **100** lowers itself so that the bottom of tray **118** is sitting upon the ground and then releases tray **118**. Device **100** would then raise itself back to a normal operating height and move away from tray **118** to allow an animal to eat and drink from the tray. Device **100** would later return to tray **118**, lower itself such that the bottom of main body **102** is generally in contact with the top of tray **118**, and reattach tray **118** to main body **102**. Tray **118** may alternatively be removably coupled to main body **102** in any suitable way. For example, tray **118** may slide into and out of a cavity in main body **102**, for example using a lip on tray **118** that engages with a track below main body **102**. Tray **118** is described in more detail in association with FIGS. 2A and 2B below.

[0035] Arm **120** comprises a movable arm operable to deliver a payload **122** to an animal. In one embodiment, payload **122** comprises a syringe for providing an injection to an animal and arm **120** is capable of articulation appropriate for providing an injection. For example, an animal may be diabetic and require an insulin injection. For another example, payload **122** may comprise an injectable or spray-based tick repellent.

[0036] Scent emitter **130** comprises a suitable system for emitting a predetermined scent. As many animals rely on scent, as opposed to visual or auditory cues, device **100** provides the caregiver the ability to provide one or more scents as appropriate for the animal under care. For example, in one embodiment, scent emitter **130** may simply comprise a cavity with a fan where an object, such as clothing worn by a caregiver, is placed to provide a familiar scent to an animal. Alternatively, scent emitter **130** may comprise more complex systems using chemicals or concentrated scents that may be sprayed or otherwise emitted from device **100** as desired by a caregiver. Scent emitter **130** may operate independently according to predetermined criteria, such as time of day, and/or may be under direct remote control by the caregiver.

[0037] According to one embodiment of the present invention, a heat/cold emitter **132** may be included with device

**100**, such as on main body **102**. Heat/cold emitter comprises one or both of a heater and/or air conditioner operable to heat and/or cool an area around device **100**. For example, in harsh environments it may be necessary to provide environmental controls for an animal, such as a pregnant horse that lives outside during unexpected weather changes or a domestic pet in the event of a power failure at a house.

[0038] Animal care device **100** also includes a secondary animal waste detection system **133** that may deploy one or more technology based on radar, ground anomaly detection, video analysis, ultrasound technology, image recognition, scent recognition, heat signature detection, chemical detection, and detection of one or more predetermined substance or device. The secondary animal waste detection system **133** may be configured to detect a substance that is used to pre-treat the deposited feces, for example. Alternatively, the animal may be fed food that contains an additive substance and/or device that can be detected by the secondary animal waste detection system **133**. The additive substance can be a specific chemical composition, a metal, and/or a micro-tag (which may be based on RFID technology or another technology now known or to be developed).

[0039] FIG. 2a is a side view of tray **118** according to one embodiment of device **100**. FIG. 2b is a top view of tray **118** according to one embodiment of device **100**. As shown in FIG. 2a, in one embodiment, tray **118** may comprise a cutout in the rear portion to account for movement of rear wheels **108**. In one embodiment, tray **118** further comprises at least one post **212** engageable within main body **102** to hold and release tray **118** from main body **102**. For example, posts **212** may engage with a solenoid within main body **102** to couple tray **118** to main body **102** and retain tray **118** with device **100**. In this example, the solenoids may be activated to latch with posts **212** or may use friction to retain tray **118**, while the deactivation of the solenoids would allow tray **118** to be released from a lower portion of main body **102**. Alternatively, tray **118** may be releasably coupled to main body **102** using a magnetic retention and release system or other suitable electrical, electro-mechanical or mechanical systems. As shown in FIG. 2b, tray **118** comprises a food portion **200**, a water portion **202** and a medicine portion **204**. Food portion **200** receives food from device **100** and contains the food for consumption by an animal. Water portion **202** receives water or other liquids from device **100** and contains the water for consumption by an animal. Medicine portion **204** receives medicine in solid or liquid form from device **100** and contains the medicine for consumption by an animal. For example, tray **118** may be a plastic tray with open-topped compartments acting as portions **200**, **202** and **204**.

[0040] In one embodiment, tray **118** may further comprise sensor **210**. Sensor **210** is operable to detect that one or more of portions **200**, **202** and/or **204** are in need of refilling and signaling to device **100** that tray **118** needs refilling.

[0041] FIG. 3 is a rear view of device **100** according to one embodiment of the present disclosure. FIG. 4 is a side view of device **100** according to one embodiment of the present disclosure. FIGS. 3 and 4 are described together for greater clarity. Device **100** further comprises a plurality of charging ports **300**, an electrical port **302**, a directional system **304**, a water bin **320**, a food bin **322**, a medicine bin **324**, a waste bin **326**, a cleaning nozzle **330**, a water suction nozzle **332**, a battery **340** and a motor **342**. Charging ports **300** comprise a food port **310**, a water port **312**, a medicine port **314** and

a waste port 316. Electrical port 302 comprises suitable electrical interfaces for recharging device 100 from a power source, such as an electrical grid tied receptacle, solar panels, wind power or other suitable electrical power sources.

[0042] Food port 310 comprises a receptacle operable to receive animal feed to refill device 100 with feed for dispensing to an animal on tray 118. Food received from food port 310 is stored in food bin 320. Food bin 320 comprises any suitable container for solid or liquid items, is disposed within main body 102 and is coupled to food port 310 via a suitable tube or pipe. In one embodiment, food bin 320 may be removed from main body 102 by opening upper body 104. For example, food bin 320 may be removed for cleaning or manual refilling.

[0043] Water port 312 comprises a receptacle operable to receive water to refill device 100 for dispensing to an animal on tray 118. Water received from water port 312 is stored in water bin 322. Water bin 322 comprises any suitable container for liquid items, is disposed within main body 102 and is coupled to water port 312 via a suitable tube or pipe. In one embodiment, water bin 322 may be removed from main body 102 by opening upper body 104.

[0044] Medicine port 314 comprises a receptacle operable to receive medicines to refill device 100 for dispensing to an animal on tray 118. Medicine received from medicine port 314 is stored in medicine bin 324. Medicine bin 324 comprises any suitable container for solid or liquid items, is disposed within main body 102 and is coupled to medicine port 314 via a suitable tube or pipe. In one embodiment, medicine bin 324 may be removed from main body 102 by opening upper body 104. In another embodiment, medicine bin 324 may be coupled to or accessible by payload 122 to in order to refill a syringe, for example, via a tube through arm 120.

[0045] In addition, one or more of bins 320, 322, 324 and/or 326 may be refrigerated or heated as needed. For example, medicine bin 324 may be required to be kept refrigerated to keep medicine from spoiling.

[0046] Waste bin 326 receives water and other debris from suction nozzle 332 for storage until the contents of waste bin 326 are removed from device 100 via waste port 316. Waste port 316 is coupled to waste bin 326 via a suitable tube or pipe to allow extraction of the contents of waste bin 326.

[0047] Cleaning nozzle 330 comprises a device operable to expel water at a suitable level of pressure to clean tray 118. Cleaning nozzle 330 is coupled to water bin 322 via a suitable tube or pipe. For example, cleaning nozzle 330 may comprise a water-spraying device that sprays water under pressure onto tray 118. In one embodiment, cleaning nozzle 330 is of a suitable size and located within main body 102 at a location such that cleaning nozzle 330 sprays water onto tray 118. In another example, cleaning nozzle 330 may be operable to move within main body 102 in order to clean portions of tray 118. In addition, cleaning nozzle 330 may represent multiple cleaning elements, such as multiple sprayers, for cleaning tray 118 in various embodiments. For example, nozzle 330 may comprise or include a heated air emitter to dry tray 118 or other surfaces. Further, in one embodiment, a bin for a cleaning solution may be further coupled between water bin 322 and cleaning nozzle 330. In yet another embodiment, nozzle 330 may be used to clean areas under device 100 after tray 118 has been detached, for example, to clean a floor.

[0048] Suction nozzle 332 comprises a device operable to remove water and/or debris from tray 118 and deposit the removed water and/or debris in waste bin 328 via a suitable tube or pipe. For example, as cleaning nozzle 330 is spraying water to clean tray 118, suction nozzle 332 is removing the used water from tray 118. In general, suction nozzle 332 comprises any suitable device or devices operable to remove used water and used cleaning fluids from tray 118. In various embodiments, cleaning nozzle 330 and suction nozzle 332 may require the use of pumps (not shown) to generate suitable levels of water pressure for cleaning tray 118 and suction force to remove liquid and/or solid debris. For example, in one embodiment, suction nozzle 332 and cleaning nozzle 330 may be used to clean surfaces other than tray 118, such as debris or waste on a floor or other surface. This embodiment may require the release of tray 118 prior to performing such cleaning activities.

[0049] Battery 340 comprises any suitable battery technology, such as lead-acid, NiMH, Lithium-Ion and NiCad, operable to power motor 342 and device 100 generally. Battery 340 is electrically coupled to charging port 300 and is recharged when charging port 300 is connected to an external power source. Battery 340 is sized as suitable for the animal being cared for by device 100 and the related power demands of motor 342 and the various electronics associated with device 100, such as wireless communications system 110. For example, an animal care device 100 for taking care of horses in an outdoor field may be larger and require a stronger motor 342 and battery 340 to deal with the relatively harsh environment. In contrast, an animal care device 100 that is primarily designed for use with a household pet may require a less powerful motor 342 and battery 340.

[0050] Motor 342 comprises a suitable motor for driving front wheels 106 and/or rear wheels 108, depending on the embodiment of device 100, to allow device 100 to move from place to place. In one embodiment, motor 342 comprises an electric motor powered by battery 340.

[0051] Directional system 304 comprises a movable joint operable to turn rear wheels 108 and to lower device 100. In one embodiment, rear wheels 108 provide directional control for device 100, while front wheels 106 provide the driving force to move device 100. In addition, to order to release tray 118 on the ground, device 100 may lower itself so that the bottom of tray 118 is on or near the ground before releasing tray 118. In this embodiment, directional system 304 pivots the rear wheels 108 to lower device 100 closer to the ground.

[0052] FIG. 5 is a block diagram of a docking station 500 for device 100 according to one embodiment of the present disclosure. Docking station 500 interfaces with charging ports 300 and electrical ports 302. Docking station 500 comprises a food recharger port 510, a water recharger port 512, a medicine recharger port 514, a waste removal port 516 and an electrical recharging interface 502.

[0053] Food recharger port 510 comprises a suitable system to couple and decouple to food port 310 in order to refill food bin 322 via food port 310. For example, food recharger port 510 and food port 310 may comprise a pair of generally hollow cylinders where one cylinder is slightly larger than the other cylinder to allow the smaller cylinder to enter into the larger cylinder to create a connection where solid and/or liquid food can pass through from food recharger port 510 to food port 310 into food bin 322.

[0054] Water recharger port **512** comprises a suitable system to couple and decouple to water port **312** in order to refill water bin **320**. For example, water recharger port **512** and water port **312** may operate similarly to ports **510** and **310**.

[0055] Medicine recharger port **514** comprises a suitable system to couple and decouple to medicine port **314** in order to refill medicine bin **324**. For example, medicine recharger port **514** and medicine port **314** may operate similarly to ports **510** and **310**.

[0056] Waste removal port **516** comprises a suitable system to couple and decouple to waste port **316** in order to allow the emptying of waste bin **326**. For example, waste bin **326** may become partially or completely filled with solid and/or liquid waste as a result of the cleaning of tray **118**. Waste removal port **516** and waste port **316** may operate similarly to ports **510** and **310**.

[0057] Electrical recharging interface **502** comprises a suitable electrical system for recharging battery **340** via port **302**. For example, interface **502** and port **302** may comprise a suitable male/female electrical connection system.

[0058] As illustrated in FIG. 5, docking station **500** may be located at a suitable location, such as a laundry room or outdoor location, for recharging and refilling device **100**. In one embodiment, docking station **500** is located outdoors and uses equipment suitable for outdoor and/or harsh environment use. Device **100** may automatically detect that one or more of bins **320**, **322**, **324** and **326** need refilling or emptying and return to docking station **500** and/or notify the caregiver that one or more of bins **320**, **322**, **324** and **326** need refilling, or that battery **340** needs recharging. Alternatively, the caregiver may remotely command device **100** to return to docking station **500** and/or device **100** may return to docking station **500** on a predetermined schedule or in response to other inputs. Docking station **500** itself may also be operable to generate a notification to the caregiver that the docking station **500** requires refilling.

[0059] In operation, device **100** may be used by an animal caregiver to assist with the care of one or more animals, regardless of whether the caregiver is physically located near the animals or is physically distant. Device **100** may be directly controlled by the caregiver, such as via a remote control or via a network connection, such as via an application on a computer, smartphone, tablet or other electronic computing device, that communicates with device **100** over a global computer network, such as the Internet. In addition, device **100** may be pre-programmed to perform various activities independently. For example, device **100** may provide food, water and/or medicine on tray **118** at predetermined times. Device **100** may also be controlled via a combination of independent programming and remote control.

[0060] Initially, or after one or more uses of device **100**, device **100** is filled and charged, or refilled and recharged, at docking station **500**. For example, device **100** may be controlled by a remote control by a human user or may be capable of automatically finding docking station **500**, such as by GPS location or a beacon of a suitable type that device **100** may navigate to. In one embodiment, device **100** rolls to docking station **500** and reverses into docking station **500**. Rear wheels **108** then articulate to allow device **100** to lower or raise itself and couple ports **300** and **302** with docking station **500**.

[0061] The animal caregiver may interact with the animal using display **116** and camera **112**. Camera **112** allows the caregiver to see the animal, and may provide a pan, tilt and/or zoom functionality to improve viewing of the animal from a remote location, such as over the Internet. Display **116** allows the animal to see an image, such as the caregiver. Display **116** comprises any suitable display system for video and audio and is capable of receiving video and audio via wireless system **110**. The audio capabilities of display **116** allow the animal to both see and hear the caregiver, and allow the caregiver to hear the animal. For example, the caregiver could program device **100** to generate familiar sounds, such as a normal pre-sleep ritual, associated with the caregiver at a certain time, such as when the animal is sleeping. In general, device **100** may play pre-recorded audio and/or video messages at pre-determined times, in response to predetermined situations and/or as commanded remotely by the caregiver, such as via an application on a smartphone used by the caregiver. In addition, toy **114** allows the caregiver to play with the animal. For another example, a veterinarian may use camera **112** to evaluate the medical condition of an animal under the care of device **100**.

[0062] As device **100** is mobile, device **100** can move around with the animal. In one embodiment, wireless system **110** generates a signal usable as an electronic fence system. Electronic fences are commonly used to keep an animal, such as a dog, within a predefined area without the use of physical barriers. For example, the electronic fence may be linked to a shock collar that indicates that the dog is not allowed to go beyond a certain point. Such an electronic fence system, when incorporated into device **100**, allows device **100** to walk an animal. For example, an animal that has been trained that the animal can only go a certain distance, such as 50 feet, away from device **100** by the electronic fence, allows device **100** to walk the animal. More specifically, since the animal knows that it must remain within a certain distance from device **100**, or be subject to appropriate corrective measure, such as an audible signal or an electronic shock from a shock collar, device **100** could, for example, move down a sidewalk along a predetermined route, or under the remote control of a caregiver, and walk an animal even though the caregiver is not physically present. In one embodiment, the electronic fence collar worn by the animal contains a water immersion detection capability to detect if the animal has entered or fallen into a body of water, such as a swimming pool, lake or pond. In this embodiment, the collar may alert device **100** that the animal has entered a body of water and the device **100** may generate an alert, such as to the remote caregiver or an emergency response group, or take other predetermined actions in response thereto.

[0063] Device **100** may use a GPS or other location device associated with device **100** and/or the animal being cared for to provide location information of the animal and/or device **100** to the animal caregiver. The location information may be used by device **100** to generate an alert to the caregiver and/or other people based on one or more predetermined conditions. For example, an alert could be generated if the animal goes beyond a certain distance from device **100**. In one embodiment, device **100** communicates with a device that tracks an animal's vital signs and responds appropriately in the event of a medical emergency. For example, if it is known that an animal has a medical condition that requires medicine only under certain circumstances, device

**100** could provide such medicine via tray **118** or payload **122** when the medical condition is detected by the vital signs monitoring device, such as in response to low blood sugar, elevated blood pressure or elevated heart rate.

[0064] In addition, device **100** may include special programming to automatically handle emergency situations. For example, device **100** may be capable of communicating with a smoke and fire detection system in a house, and use the electronic fence functionality to bring a house pet outside in the event of a fire, such as by decreasing the distance of the electronic fence to keep the animal close to device **100** until device **100** and the animal have reached a safe or predetermined location. In one embodiment, device **100** may itself be equipped with a carbon monoxide detector, smoke detector, fire detector and/or other sensors to detect toxic fumes, smoke, fire or other hazards. For example, device **100** may include a glass break sensor along with programming to know that device **100** and an animal under the care of device **100** are alone in a structure, and that a glass break represents a potential intruder. For another example, device **100** may include programming to generate an alert to an emergency service, such as a fire department, that includes images, description and count of the animals under the care of device **100**. Such an alert may be sent when device **100** detects a hazardous situation, such as a fire, so that emergency responders are aware of the number and identity of animals in a structure. In addition, such an alert may include medical information, such as drug allergies, handicaps or pregnancy, of animals under care of device **100** to assist medical personnel in an emergency. Further, such an alert may also include the planned emergency evacuation location that device **100** will lead animals to in the event of an emergency to assist first responders in locating the animals. In general, device **100** may be programmed to communicate current and/or historical data associated with one or more sensors associated with device **100** to the caregiver and/or may be commanded by the caregiver to provide such data.

[0065] Tray **118** allows device **100** to feed, water and provide medicine to animal. In one embodiment, when an animal is to be fed, such as device **100** being preprogrammed with feeding times, determining feeding is necessary according to predetermined criteria or is commanded to feed the animal by the caregiver, device **100** fills tray **118** with food, water and medicine (if needed). For example, food, water and medicine from bins **320**, **322** and **324** may be respectively deposited in tray portions **200**, **202** and **204**. Tray **118** may use portions **200**, **202** and/or **204** for uses other than food, water and medicine. For example, portion **200** may be used as a cat litter box instead of providing food.

[0066] Device **100** then lowers itself so that the bottom of tray **118** is generally in contact with the ground and releases tray **118**. For example, device **100** may use rear wheels **108** to pivot the front of device **100** generally downward and then reverse, while allowing tray **118** to slide out. Alternatively, after the bottom of tray **118** is generally in contact with the ground, device **100** may release tray **118** and raise itself back up to a normal operating height and leave tray **118** on the ground. In general, any suitable system for releasing and recovering tray **118** may be used by device **100**.

[0067] After the animal has finished eating and drinking, device **100** retrieves and cleans tray **118**. For example, device **100** may lower itself over tray **118**, reattach tray **118** to device **100**, and raise itself back to a normal operating

height. Alternatively, device **100** may slide tray **118** back into device **100**. Device **100** then cleans tray **118** using cleaning nozzle **330** and suction nozzle **332**. In one embodiment, device **100** may also use cleaning nozzle **330** and suction nozzle **332** to clean up detected debris, such as animal excrement or soil from a flowerpot knocked over by an animal. For example, caregiver could notice such debris via camera **112** and remotely control device **100** to leave tray **118** at a suitable location to allow use of nozzles **330** and **332** to clean up such debris. Alternatively, or in addition, device **100** may automatically detect such debris and perform an appropriate cleaning operation. In addition, in one embodiment, device **100** may include a heater and/or air blower device associated with nozzles **330** and/or **332**, to dry the area cleaned by nozzles **330** and **332**. Further, in another alternative embodiment, scent emitter **130** may include the additional ability to emit a scent designed to be pleasing to humans, such as a scent similar an air freshener that is emitted on or near a recently cleaned area to lessen offensive odors that may remain after the cleaning process.

[0068] Device **100** may also communicate with a home automation system that allows device **100** to open and close doors in a structure. For example, device **100** could wirelessly lock and unlock doors equipped with appropriate devices and push open doors for the animal at appropriate times, such as to allow the animal outside to play at certain times. In addition, device **100** may use such control over doors to control which areas of a structure that an animal is allowed to enter or prohibited from entering. Device **100** may also use such a home automation system to control environmental conditions, such as a heater or air conditioner. In addition, in one embodiment, device **100** may also communicate with a security system to allow an animal to move about the house without activating the alarm. For example, many security systems use motion detectors to provide security for a structure, however, such motion detectors often generate false alarms when an animal triggers the motion detector. Device **100** may avoid such false alarms by deactivating the motion detector when location information associated with an animal indicates that an animal is near a motion detector controlled area. For another example, device **100** may detect that a dog has spent a significant amount of time in front of a door that the dog uses when the dog needs to relieve itself. Upon detecting that the dog has been in front of the door for an appropriate period of time, device **100** could unlock and/or open the door to let the dog out, and deactivate the alarm system on that door to prevent a false alarm, while still allowing the alarm system to be used with an animal in the house.

[0069] Device **100** may also record the location of itself and/or the animal and provide such information to the caregiver. For example, device **100** may use the GPS device to provide a map of movements over a period of time to the caregiver via a remote data connection.

[0070] Device **100** may also include programming to detect if the animal has remained stationary for an abnormally long period of time, such as by using GPS information communicated from a collar worn by the animal to device **100**. For example, if a normally active animal has not moved for several hours, this may indicate a medical problem or that the animal is deceased. The programming may take any suitable action in response thereto, such as generating an alert to the caregiver or an emergency response group, or by providing medicine to the animal, such as via arm **120**.



[0071] The animal care device 100 may be preprogrammed with a “route” to walk an animal or a human can control the animal care device 100 remotely to move it along a path walking the animal either with a tethered leash or using the wireless “geofence” which uses the smart collar 608 to determine one or more of the animals current position, its direction of travel, its distance from the animal care device 100, its proximity to known hazards (lakes, pools, streets, highways) and the animal care device 100 administers to the animal via the smart collar 608 or a separate shock collar, a corrective shock or other type of corrective signal (audio/video) to cause the animal cease its movement in a specific direction, cause it to move, cause it to maintain a certain distance within a predetermined perimeter of the animal care device 100 or affect the animals movement or behavior in any way.

[0072] FIGS. 6-8 are diagrams illustrating information flows in exemplary embodiments of an animal care device 100 according to the teachings of the present disclosure and are described in turn. The animal care device 100 is equipped with a bark recognition sensor logic capable of “learning” unique barks or sounds of distress associated with individual animals 600 and differentiating between the barks or distress sounds to determine which individual animal 600 is making the sound, if multiple animals are present and notifying the owner of one-time or continuous dog barking and identifying the dog that is barking. The animal care device 100 is capable of interfacing with and activating personnel or home security system 606 (alarm, directing security cameras toward the sound of the barking, etc.) if the barking exceeds certain parameters (example, constant barking for more than 30 minutes, etc.) and also notifies the owner via a user computing device 602, e.g., cell phone, tablet, or computer, or notify a third person or agency 604. The animal care device 100 may take action based on the bark i.e., arming the security system 606, and/or opening a door to allow egress or access to the outside or inside of a building or room. Having the animal care device 100 begin recording when a bark is detected, or alert the owner of a possible threat and allow the owner to view the location via the audio video features of the animal care device 100.

[0073] The animal care device 100 may operate in a bark suppression mode to dissuade and prevent an animal 600 from making certain noises (i.e., bark suppression system consisting of an audible noise or image or a preset message from the owner or a noise emitter to calm a horse when the animal care application recognizes noises or sounds associated with the animal being “spooked”). The system can be activated by a preset sensing system or by a library of sounds recorded and loaded onto the system with a unique suppression or calming response programmed for each noise in the library.

[0074] FIGS. 9A and 9B are illustrations of an exemplary embodiment of a smart collar 608 and a dog 600 wearing the smart collar 608 according to the teachings of the present disclosure. FIGS. 10A and 10B are illustrations of an exemplary embodiment of a smart harness and a dog wearing the smart harness 610 according to the teachings of the present disclosure. For purposes of this disclosure, the smart collar 608 and smart harness 610 are equivalent in functionality in the animal care technology described herein. FIG. 11 is a diagram illustrating a variety of applications for a smart collar 608 according to the teachings of the present disclosure.

[0075] FIGS. 12 and 13 are diagrams illustrating information flows in exemplary embodiments of an animal care device 100 operating cooperatively with a smart collar according to the teachings of the present disclosure. The smart collar 608 will detect geographical coordinates using GPS (global positioning system) 612 and other suitable methods, and can be both preprogrammed with known animal characteristics from a library of known animal movements or capable of learning and storing the movement a particular animal movements and associating those movements with a certain activity the animal is performing (i.e., eating, jumping on the couch, defecating, chasing another animal, sleeping, chewing on something, etc.) and based on the activity the animal care device 100 will respond with a preprogrammed response based on the activity the animal 600 is involved in (example jumping on the couch when it is not supposed to) or a combination of learned traits combined with GPS (global positioning system) location (i.e., the animal is in the living room, on the couch, exhibiting a movement consistent with eating, the animal care device 100 is programmed to assume it is chewing on a pillow and responds with an audio, audio/video, alarm or collar shock or other response designed to correct the animal 600 and stop the behavior. It may also alert the owner and allow the owner to initiate a response remotely or speak to the animal via video or audio to correct the action.

[0076] In the excrement cleanup application, the smart collar 608 will interpret movements related to the animal defecating and transmit the location (e.g., absolute such as latitude and longitude or relative to one or more landmarks in the yard or residence) of probable defecation (“LPD”) to the animal care device 100 which will then, automatically or after manual initiation by a human, perform a cleaning function by going to those locations of high probability, cleaning the feces by scoop, vacuum, pincher, shovel or other method, storing the feces in the animal care device 100 and allowing the feces to be expelled either automatically by the animal care unit and preprogrammed time and location or manually by the owner. The animal care device 100 may also be capable of packaging the feces in a bag, membrane or covering for easy disposal. In another embodiment, an on-board incinerator may burn the feces or use chemicals or other methods to destroy the feces. Alternatively, the animal care device 100 may alert the owner who may manually initiate the process.

[0077] The smart collar 608 and animal care device 100 may cooperate for additional functions. For example, the smart collar 608 and/or animal care device 100 may be capable of taking an animal’s external body temperature via thermal imaging or any other heat sensing technology, or via a probe extended from the animal care device 100 to make contact with the animal. The system would notify a remote entity or third party (owner, veterinarian, etc.) if the animal’s body temperature is out of a preset range and prompt attention is required.

[0078] The animal care device 100 may be further equipped with a wirelessly-connected interface with an existing or designed weather reporting or forecasting application to allow the animal care device to determine or restrict the activity of the animal based on the current weather or the forecast (i.e., don’t let the dog out in the yard in a lighting storm, or turn up the heat if cold weather is forecasted). A pre-programmed animal “care” routine based on the time of day, day of week, actions of the animal,

weather or any other factor may direct the animal care device **100** to initiate a sequence of actions based on a particular time or circumstance so that the animal is away from possible harm and is in a safe and comfortable environment.

**[0079]** A recording system may be mounted on-board the animal care device **100** that can record and store external images, video or environmental conditions continuously, or on a pre-configured time schedule or based on some external event. These images may be transmitted to one or more destinations for viewing online by the owner or other authorized personnel. The images may further be analyzed for threat detection.

**[0080]** A self-contained medical diagnostic program may be on-board the animal care device **100** that senses, via the smart collar **608** or other input, that the animal's behavior or vital signs are consistent with some type of illness or distress, and administers care and/or medicine to address behavior or vital signs associated with illness or distress. For example, if the animal care device **100** determines the animal is making body movements consistent with scratching, it may administer tick prevention medicine. If the animal care device **100** determines that the animal is dragging its hind quarters across the floor, it may administer worming medicine. The animal care device **100** response may also be triggered by medical events recognized by the smart collar and an on-board medical library that matches the movements of the animal to the probability of certain injuries, sicknesses or illnesses.

**[0081]** An on-board stool examination component incorporated within or attached to the animal care device **100** that is locates and gathers an animal's stool/feces automatically (feces cleanup technology) or a sample is loaded manually, and then examined and evaluated for signs of disease, parasites (worms, etc.) or other abnormalities, and alerts a person (owner, caretaker, veterinarian) of the results of the stool evaluation.

**[0082]** An on-board "radar" or "threat detection" system or animal "facial recognition" component(s) incorporated within or attached to the animal care device **100** that detects other animals in the proximity of the animal associated with the animal care device **100** and alerts a person of the nearby animal or potential threat. The system may have an "intelligent" or artificial intelligence component that interprets the movements, size, mannerisms, geo-location (does the possible list of animals detected have a population in the area?), etc. For example, if the animal care device **100** detects a bear and the geo-coordinates indicate the associated animal is in Alaska, the system would identify the possible threat specifically as a Brown Bear. If the animal care device detects a larger upright animal and the geo location determines the associated animal is in Australia, the threat may be identified as a Kangaroo).

**[0083]** The animal care device **100** and/or the smart collar **608** may have a camera/video capture component which interfaces with a facial recognition database. The camera/video component can evaluate images of a person or persons near the device or the associated animal and determine if the person is known (owner, caregiver, veterinarian, etc.) or unknown or if the person is a known potential threat. If the person is not a known or "allowed" person the animal care unit may control the movement of the associated animal to keep the animal away from the person for the protection of the animal or the unknown person. The animal care device

**100** may also issue an audible or visual warning or message, or if the person is known, it may issue a message (e.g., "Hello Joe, Rover has not eaten yet today but has gone to the bathroom within the last 10 minutes.")

**[0084]** The smart collar **608** facial recognition component may be interfaced, either directly or via the animal care device **100**, to a system that notifies a remote entity, such as a third person or agency if an unauthorized individual is detected in a certain area (i.e., intruder in house), the person is in need (i.e., missing Alzheimer's patient) or a threat to people in the area (sex offender detected at a playground near kids).

**[0085]** The animal care device **100** may have an audible or visual warning that locates and contacts the animal owner (either via a wireless communication, text, cellphone etc.) or identifies the owner in proximity to the animal care device **100** (via the facial recognition or other identification technology) and reminds the owner that attention is needed by the associated animal ("Joe, Rover needs his allergy shot within the next 2 days" or "Joe, please remember that Rover has a doctor's appointment on Tuesday at 1:00 pm").

**[0086]** The smart collar with the on-board camera/video capture device may transmit images to the associated animal care device **100** or a separate database for comparison with known persons who may be missing, wanted by authorities, or in need of assistance. It may also use facial recognition technology to identify individual animals and identify them as belonging at the location or missing from another location.

**[0087]** The smart collar **608** may be equipped with a hazardous substance or gas detection component that identifies potential air quality threats to the animal **600**, other animals or persons in the area. Upon detecting such hazards in the environment, it may transmit information to a home security system, or the animal care giver or other persons either directly or via the animal care device **100**.

**[0088]** The smart collar **608** may be equipped with a wireless audio component that interfaces with an external application to allow a person to give audible instructions or reassurances to the animal from a distance. The user interface may be an application executing on a mobile device, such as a mobile phone, for example.

**[0089]** FIG. 14 is a simplified block diagram of an exemplary embodiment of an animal care device **100** in operation with a smart collar **608** according to the teachings of the present disclosure. The animal care device **100** includes a microprocessor **700** in communication with a wireless communication system **702** that enables data to be transmitted to and from the animal care device **100**. The term "wireless communication" herein is used broadly to refer to any communication channel, now known or to be developed, that can be used to transmit and receive data signals without any physical or tangible medium such as a copper line or fiber optic cable. However, it is contemplated that physical transmission media may be employed along at least some portion of the network path from the origination point (e.g., animal care device **100**) to the termination point of the data (e.g., remote entity **714**).

**[0090]** The animal care device **100** further includes an imaging system **704** operable to take still photographs and/or video images. The animal care device **100** further includes a mobility portion **706** that enable it to move about its environment according to instructions from the microprocessor **700**. An additional equipment is a robotic actuator

**708**, in the form of, for example, scoop, vacuum, pincher, shovel or combination thereof that is operable to pick up, sample, and dispose of items, such as the animal's feces. The microprocessor **700** is also operable to access a memory **710** for executable program code and to store and read data. The microprocessor **700** is also able to communicate with an automated laboratory **712** to receive laboratory report and analysis generated by the laboratory. The wireless communication device **702** on-board the animal care device **100** may further enable it to communicate with a remote entity **714**, such as home security monitoring service, a computing device of the owner, or a separate security/home maintenance system **606**. In addition, the animal care device **100** may be in communication and/or controlled by a home security/maintenance system. In particular, the microprocessor on-board the animal care device **100** may be optional, and the animal care device **100** may be instead under the control of a microprocessor **716** of the home security/maintenance system via its wireless or wired communication system **718**. In addition, the smart collar **608**/harness **610** includes a wireless communication system **720** for communications with the animal care device **100** (or in the alternative, with the home security/maintenance system). The smart collar **608** also includes an imaging system **722** for capturing still photographs and video images, a measuring device **724** capable of measuring or sampling a variety of substances and/or states (liquid, gas, body temperature, pulse rate, etc.), and a microphone **726** for receiving audio data, and a speaker **726** for generating audio signals. The smart collar **608** may include an on-board microprocessor **728** and a GPS system **730** for determining a geo-location of the animal wearing the smart collar **608**.

[0091] FIG. 15 is a simplified diagram of another exemplary embodiment of an animal care device **800** in operation with a plurality of user computing devices **602** according to the teachings of the present disclosure. A water-tight, hardened, automated and remotely-controlled animal boarding animal care device **800** is designed to withstand all of nature's adverse elements including wind, cold, heat, and flood water. Further contemplated is the use of the care device for protection from harmful environmental substances such as nuclear radiation, and bio, viral, fungal, or chemical agents, to prevent exposure to these toxic agents. The care device **800** is equipped with a computer that may automatically initiate pre-programmed functions in response to a potentially hazardous environmental event warning issued by a local, state or federal private or government agency. Although the focus is the protection of pet animals, these devices can be constructed for human use. As described above, the animal care device **800** provides various capabilities useful for providing care to an animal. For example, the animal care device **800** may house a dog, provide shelter, food, water, and medicine. In particular, the animal care device **800** is designed to provide protective shelter in adverse conditions, and shield the animal from harmful environmental conditions, such as floods, hurricanes, tornadoes, toxic or bio-hazardous agents, and even nuclear radiation.

[0092] As described above, animal care device **800** is equipped with a bark recognition sensor logic capable of "learning" unique barks or sounds of distress associated with individual animals and differentiating between the barks or distress sounds to determine which individual animal is making the sound, if multiple animals are present and

notifying the owner of one-time or continuous dog barking and identifying the dog that is barking. The animal care device **800** is capable of interfacing with and activating personnel or home security system **606** (alarm, directing security cameras toward the sound of the barking, etc.) if the barking exceeds certain parameters (example, constant barking for more than 30 minutes, etc.) and also notifies the owner via a user computing device **602**, e.g., cell phone, tablet, or computer, or notify a third person or agency **604**. The owner may also issue control and instructions to the animal care device **800** to perform certain functions. The animal care device **800** may take action based on the bark i.e., arming the security system **606**, and/or opening a door to allow egress or access to the outside or inside of a building or room. Having the animal care device **800** begin recording when a bark is detected, or alert the owner of a possible threat and allow the owner to view the location via the audio video features of the animal care device **800**.

[0093] FIG. 16-18 are simplified diagrams of an exemplary embodiment of one or more animal care devices **800** in operation with a plurality of smart collars **608**/harnesses **610** according to the teachings of the present disclosure. The system may be configured easily and flexibly to accommodate any number of animal care devices and collars/harnesses. The collar/harness communicates wirelessly with user computing devices, the GPS satellite constellation, cellular telephone network, home security monitoring service, and/or local agencies. Further as described above, the animal care device **800** and/or the smart collar **608** has a camera/video capture component which captures and records the activities of the animal, the environment, and persons/intruders. The smart collar **608** facial recognition component may be interfaced, either directly or via the animal care device **800**, or to a system that notifies a remote entity. The smart collar with the on-board camera/video capture device may transmit images to the associated animal care device **800** or a separate database for comparison with known persons who may be missing, wanted by authorities, or in need of assistance. When there are multiple animals wearing smart collars/harnesses present, the collars/harnesses may also communicate among them and relay information where necessary.

[0094] The smart collar **608** may be equipped with a hazardous substance or gas detection component that identifies potential air quality threats to the animal **600**, other animals or persons in the area so that appropriate action may take place, such as opening the door so that the animal may enter the shelter.

[0095] FIGS. 19-21 are a simplified diagrams of an exemplary embodiment of a mobile animal care device **816** in operation with one or more user computing devices **602** and/or one or more smart collars/harnesses according to the teachings of the present disclosure. The animal care device **800** includes a mobility portion including wheels **817** that enable it to move about its environment according to instructions issued remotely or by its onboard microprocessor. The wheels **817** preferably can be folded when not in use, and extended when the animal care device is moving about. A motor **820** represents the mechanism that drives retraction of the wheels **817**.

[0096] The animal care device **800** includes an entrance door **801** that can be shut and sealed once the animal has entered the enclosure pod. The entrance door **801** can be remotely controlled and operated (opened and shut) via

wireless communication and mobile devices such as smart-phones, laptop computers, and other devices. Once the door is shut, the animal care device **800** provides 360 degrees of sealed protection to an enclosed animal thereby creating a “safety-pod” type enclosure pod to protect from a variety of environmental elements.

[0097] FIGS. 22-24 are cross-sectional side views of an exemplary embodiment of an animal care device **816** with an anchoring and elevation mechanism according to the teachings of the present disclosure. The animal care device **800** is configured to move to its designated anchor spot, and be mounted securely to a firm and solid surface such as a concrete pad and/or dock **818**. The animal care device **800** includes a hardened outer shell that could withstand high winds, flying objects and pressure from items that might fall upon it or strike it. It would be insulated to withstand high and low temperature variations. Further, the hardened outer shell may include materials that would block the penetration of nuclear radiation. The animal care device **800** is preferably constructed of a fire-proof or fire-resistant material. The hardened shell defines an inner chamber that can comfortably house and accommodate one or more animals (e.g., dog, cat, bird, etc.).

[0098] The animal care device **800** can be raised and lowered into a hardened and secure structure **823** formed in the ground or a separate hardened structure above the ground such as a garage. The raised position permits access to the door of the animal care device, and the lowered position permits further protection by the surrounding structure **823** and the ground. The lowered position is more optimal for protection against a tornado, for example. The elevation mechanism **821** include a motor **826** or another mechanism powered by one or more batteries **825**. The power system may also include connection to the electric grid and to a wind and/or solar generator. The elevation mechanism may include pneumatic, hydraulic, and other conventional components **822**. The motor **826** is preferably in communication with the computer controller to enable remote control of its operations, preferably via user computing devices such as a smartphone. The elevation mechanism **821** may also be activated on-site by one or more user interfaces coupled to the computer controller.

[0099] Referring also to FIG. 25, when the animal care device **800** is lowered into the ground, a purified air supply system **806** supplies fresh and filtered air to a heating/cooling system **804** and **805**. The air may be supplied from outside of the device or the device may be equipped with a certain quantity of air supply (e.g., air tanks). The computer controller **507** and a thermostat are programmed to automatically sense the interior temperature and air quality so that the interior environment of the animal care device **800** is regulated to ensure comfort of the occupant. The animal care device **800** may also include a variety of sensors that may sense the outside environmental conditions for communications to a remote user. For example, the sensors may detect that the pod is underwater, experiencing high temperatures (possibly indicating fire hazard), or that certain harmful agents, such as carbon dioxide, carbon monoxide, and other poisonous substances, are present. The computer controller **507** is programmed with decisions and logic to consider these factors to maintain the safety of the occupant. The computer controller **507** is coupled to a user interface that enables input of commands and instructions and display of status and other data. For example, the pod may be raised

in case of flood, ventilation or oxygen stores may be activated or increased in the presence of certain hazardous gases, fire retardant chemicals may be released in case of fire, etc. Further, automatic notification of the owner, private security firms, or government emergency response agencies may be transmitted when appropriate.

[0100] The animal care device **800** further includes a self-contained automated feeding and watering food/water/medicine dispenser **803** and tray **802**. The dispenser **803** includes a sensor that detects whether the food tray and/or the water tray need to be replenished, and a computer controller **807** that is configured to dispense pre-portioned amount of food and water as necessary. The food and water dispenser may alternatively operate based on a pre-programmed schedule, and further subject to remote-control by the user. The automated system is powered by a power supply such as one or more batteries **825**, that can be powered by the electric grid, and solar and/or wind generators.

[0101] The animal care device **800** also includes a GPS beacon **811** or another type of electronic location positioning technology capable of emitting and receiving signals so that the presence and location of the enclosure pod can be quickly determined to effect a rescue. The animal care device **800** may also include at least one light source **815** as well as a display monitor and camera device **813** (including speakers and a microphone) to allow for two-way image and audio communication between the animal and a remotely-located user via the Internet or other communication networks. The lighting system **815** can be regulated (brightened and dimmed) by the computer controller **807** to simulate day and night cycles. This lighting system is designed to regulate the animal’s internal biological clock to allow the animals eating, sleeping and other habits to not be adversely affected. The animal care device **800** may also include a smart collar or another device to measure vital signs (pulse, temperature, etc.) of the animal and communicate this information to the remote user. The communication system may include an antenna **809** and a modem or transceivers **810** to enable the sending and receiving of data.

[0102] The animal care device **800** would also be capable of emitting a bright light such as a strobe light **808**, audible noise (siren), or specialized scent to allow the animal care device **800** to be located by third parties or other animals. The animal care device **800** preferably include a waste containment system **814** designed to allow waste materials and debris such as feces and urine to pass through a structure such as a grate disposed at the bottom of the enclosure pod to a holding chamber that collect and store the waste. The waste containment system **814** may further include mechanism to discharge the waste from the pod when conditions permit.

[0103] The animal care device **800** preferably includes a play element or toy to allow the dog or another animal to remain occupied and alert. The animal care device **800** may also have the capability of playing pre-programmed messages and/or images stored in a memory accessible by the computer controller **807** on a predetermined time schedule or remotely activated basis.

[0104] FIG. 26 is a top view of an exemplary embodiment of the locking pins **819** according to the teachings of the present disclosure. The locking pins **819** is one type of anchoring mechanism that may be used to securely fasten

the animal care device to the concrete structure so that it remains in place despite strong winds and flood waters.

**[0105]** As will be appreciated by one skilled in the art, aspects of the present invention may be embodied as a system, method or computer program product. Accordingly, aspects of the present invention may take the form of an entirely hardware embodiment, an entirely software embodiment (including firmware, resident software, micro-code, etc.) or an embodiment combining software and hardware aspects that may all generally be referred to herein as a "circuit," "module" or "system." Furthermore, aspects of the present invention may take the form of a computer program product embodied in one or more computer readable medium(s) having computer readable program code embodied thereon.

**[0106]** Any combination of one or more computer readable medium(s) may be utilized. The computer readable medium may be a computer readable signal medium or a computer readable storage medium. A computer readable storage medium may be, for example, but not limited to, an electronic, magnetic, optical, electromagnetic, infrared, or semiconductor system, apparatus, or device, or any suitable combination of the foregoing. More specific examples (a non-exhaustive list) of the computer readable storage medium would include the following: an electrical connection having one or more wires, a portable computer diskette, a hard disk, a random access memory (RAM), a read-only memory (ROM), an erasable programmable read-only memory (EPROM or Flash memory), an optical fiber, a portable compact disc read-only memory (CD-ROM), an optical storage device, a magnetic storage device, or any suitable combination of the foregoing. In the context of this document, a computer readable storage medium may be any tangible medium that can contain, or store a program for use by or in connection with an instruction execution system, apparatus, or device.

**[0107]** A computer readable signal medium may include a propagated data signal with computer readable program code embodied therein, for example, in baseband or as part of a carrier wave. Such a propagated signal may take any of a variety of forms, including, but not limited to, electromagnetic, optical, or any suitable combination thereof. A computer readable signal medium may be any computer readable medium that is not a computer readable storage medium and that can communicate, propagate, or transport a program for use by or in connection with an instruction execution system, apparatus, or device.

**[0108]** Program code embodied on a computer readable medium may be transmitted using any appropriate medium, including but not limited to wireless, wireline, optical fiber cable, RF, etc., or any suitable combination of the foregoing.

**[0109]** Computer program code for carrying out operations for aspects of the present invention may be written in any combination of one or more programming languages, including an object oriented programming language such as Java, Smalltalk, C++ or the like and conventional procedural programming languages, such as the "C" programming language or similar programming languages. The program code may execute entirely on the user's computer, partly on the user's computer, as a stand-alone software package, partly on the user's computer and partly on a remote computer or entirely on the remote computer or server. In the latter scenario, the remote computer may be connected to the user's computer through any type of network, including a

local area network (LAN) or a wide area network (WAN), or the connection may be made to an external computer (for example, through the Internet using an Internet Service Provider).

**[0110]** Aspects of the present invention may be described with reference to flowchart illustrations and/or block diagrams of methods, apparatus (systems) and computer program products according to embodiments of the invention. It will be understood that each block of the flowchart illustrations and/or block diagrams, and combinations of blocks in the flowchart illustrations and/or block diagrams, can be implemented by computer program instructions. These computer program instructions may be provided to a processor of a general purpose computer, special purpose computer, or other programmable data processing apparatus to produce a machine, such that the instructions, which execute via the processor of the computer or other programmable data processing apparatus, create means for implementing the functions/acts specified in the flowchart and/or block diagram block or blocks.

**[0111]** These computer program instructions may also be stored in a computer readable medium that can direct a computer, other programmable data processing apparatus, or other devices to function in a particular manner, such that the instructions stored in the computer readable medium produce an article of manufacture including instructions which implement the function/act specified in the flowchart and/or block diagram block or blocks.

**[0112]** The computer program instructions may also be loaded onto a computer, other programmable data processing apparatus, or other devices to cause a series of operational actions to be performed on the computer, other programmable apparatus or other devices to produce a computer implemented process such that the instructions which execute on the computer or other programmable apparatus provide processes for implementing the functions/acts specified in the flowchart and/or block diagram block or blocks.

**[0113]** The terminology used herein is for the purpose of describing particular embodiments only and is not intended to be limiting of the invention. As used herein, the singular forms "a", "an" and "the" are intended to include the plural forms as well, unless the context clearly indicates otherwise. It will be further understood that the terms "comprises" and/or "comprising," when used in this specification, specify the presence of stated features, integers, steps, operations, elements, and/or components, but do not preclude the presence or addition of one or more other features, integers, steps, operations, elements, components, and/or groups thereof.

**[0114]** The corresponding structures, materials, acts, and equivalents of all means or step plus function elements in the claims below are intended to include any structure, material, or act for performing the function in combination with other claimed elements as specifically claimed. The description of the present invention has been presented for purposes of illustration and description, but is not intended to be exhaustive or limited to the invention in the form disclosed. Many modifications and variations will be apparent to those of ordinary skill in the art without departing from the scope and spirit of the invention. The embodiment was chosen and described in order to best explain the principles of the invention and the practical application, and to enable others of ordinary skill in the art to understand the invention for

various embodiments with various modifications as are suited to the particular use contemplated.

**[0115]** The flowchart and block diagrams in the figures illustrate the architecture, functionality, and operation of possible implementations of systems, methods and computer program products according to various embodiments of the present invention. In this regard, each block in the flowchart or block diagrams may represent a module, segment, or portion of code, which comprises one or more executable instructions for implementing the specified logical function (s). It should also be noted that, in some alternative implementations, the functions noted in the block may occur out of the order noted in the figures. For example, two blocks shown in succession may, in fact, be executed substantially concurrently, or the blocks may sometimes be executed in the reverse order, depending upon the functionality involved. It will also be noted that each block of the block diagrams and/or flowchart illustration, and combinations of blocks in the block diagrams and/or flowchart illustration, can be implemented by special purpose hardware-based systems that perform the specified functions or acts, or combinations of special purpose hardware and computer instructions.

What is claimed is:

1. A system for remote care of an animal comprising:
  - a robotic animal caregiver including:
    - a housing;
    - a wireless data communication system disposed within the housing and wirelessly communicatively coupled with an external data communications system; and
    - a microprocessor in communication with the wireless data communication system disposed within the housing; and
  - a smart collar to be worn by the animal operable to determine a geo-location of the animal and communicate with the microprocessor.
2. The system of claim 1, wherein the smart collar is operable to transmit the geo-location information to the microprocessor, the microprocessor being operable to issue a corrective action to the animal via the smart collar in response to determining that the animal is approaching a prohibited geographic zone.
3. The system of claim 1, wherein the smart collar is operable to transmit the geo-location information to the microprocessor, the microprocessor being operable to issue an encouraging action to the animal via the smart collar in response to determining that the animal is approaching a specified geographic zone.
4. The system of claim 1, wherein the robotic animal caregiver is operable to determine that the animal is about to defecate at a location where defecation is prohibited, and instructs the smart collar to administer a corrective action to the animal in response thereto.
5. The system of claim 1, wherein the robotic animal caregiver is operable to determine that the animal is defecating at a location where defecation is prohibited, and issues an electronic notification that may be transmitted to an electronic device.
6. The system of claim 1, wherein the smart collar further incorporates a video imaging system operable to generate video data and transmit to the microprocessor, and the microprocessor being operable to receive and analyze the video data to determine a proper course of action in response to the geo-location and video analysis data.

7. The system of claim 1, wherein the smart collar further incorporates a video imaging system operable to generate video data and transmit to the microprocessor, and the microprocessor being operable to receive and analyze the video data to detect a threat in the animal's environment in response thereto.

8. The system of claim 1, wherein the smart collar further incorporates a video imaging system operable to generate video data and transmit to the microprocessor, and the microprocessor being operable to receive and analyze the video data to detect a threat in the animal's environment in response to the geo-location and video analysis data, and determine a proper course of action in response thereto.

9. The system of claim 1, wherein the smart collar further incorporates a video imaging system operable to generate video data and transmit to the microprocessor, and the microprocessor being operable to receive and analyze the video data to identify a person captured in the video data using facial recognition, and determine a proper course of action in response thereto.

10. The system of claim 1, wherein the smart collar further incorporates a microphone operable to receive audio data and transmit the audio data to the microprocessor, and the microprocessor being operable to receive and analyze the audio data to determine a proper course of action in response thereto.

11. The system of claim 1, wherein the smart collar further incorporates a microphone operable to receive audio data including barking sounds and transmit the audio data to the microprocessor, and the microprocessor being operable to receive and analyze the audio data including barking sounds to determine a proper course of action in response thereto.

12. The system of claim 1, wherein the smart collar further incorporates a microphone operable to receive audio data including sounds unique to the animal and transmit the audio data to the microprocessor, and the microprocessor being operable to receive and analyze the audio data including unique sounds to determine a proper course of action in response thereto.

13. The system of claim 1, wherein the smart collar further incorporates a microphone operable to receive audio data including prolonged barking sounds and transmit the audio data to the microprocessor, and the microprocessor being operable to receive and analyze the audio data including prolonged barking sounds, and instruct the smart collar to administer a corrective action in response thereto.

14. The system of claim 1, wherein the smart collar further incorporates a microphone operable to receive audio data including prolonged barking sounds and transmit the audio data to the microprocessor, and the microprocessor being operable to receive and analyze the audio data including prolonged barking sounds, and instruct the smart collar to playback a recorded audio message in response thereto.

15. The system of claim 1, wherein the smart collar further incorporates a sensor operable to detect environmental hazardous substances and transmit the detected hazard substance information to the microprocessor, and the microprocessor being operable to receive and analyze the detected hazard substance information to determine a proper course of action in response thereto.

16. The system of claim 1, wherein the smart collar further incorporates a sensor operable to detect a threatening condition in existence in the animal's environment and transmit the threatening condition information to the micro-

processor, and the microprocessor being operable to receive and analyze the detected threatening condition information to determine a proper course of action in response thereto.

**17.** The system of claim 1, wherein the smart collar further incorporates a temperature sensor operable to measure at least one of body temperature of the animal and ambient temperature, and transmit the temperature information to the microprocessor, and the microprocessor being operable to receive and analyze the temperature information to determine a proper course of action in response thereto.

**18.** The system of claim 1, wherein the smart collar further incorporates sensors operable to measure vitals data of the animal and transmit the vitals data to the microprocessor, and the microprocessor being operable to receive and analyze the vitals data to determine a proper course of action in response thereto.

**19.** The system of claim 1, wherein the microprocessor is operable to receive the geo-location information of the animal from the smart collar and a weather report, and analyze the weather report and geo-location information to determine a proper course of action in response thereto.

**20.** The system of claim 1, wherein the microprocessor is operable to determine a proper course of action in response to a stored activity routine of the animal and the geo-location information of the animal.

\* \* \* \* \*