

Henry Juge
Eyeletting Machine

N^o 63,904.

Patented Apr. 16 1867.

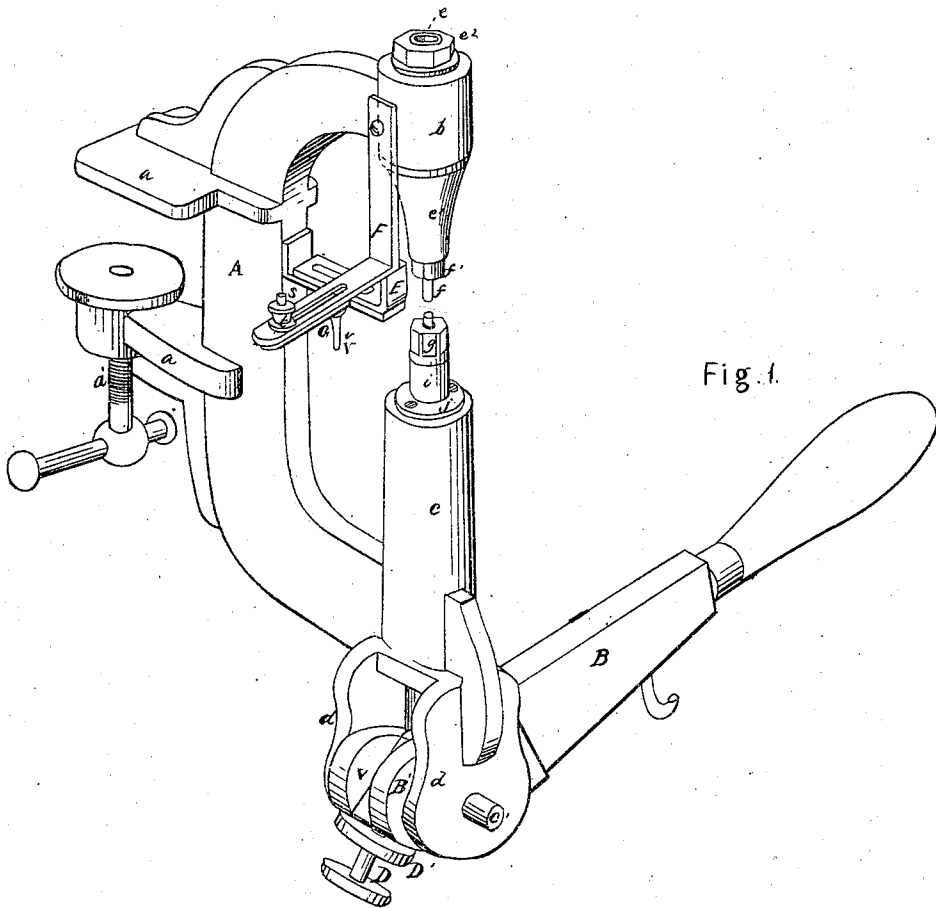

Fig. 1.

Witnesses.
R. T. Campbell.
Edw. Schafer

Inventor
H. Juge
by
Mason F. H. Lawrence

Henry Juge. Eyeletting Machine.

N^o 63,904.

Patented Apr. 16. 1867.

Fig. 2.

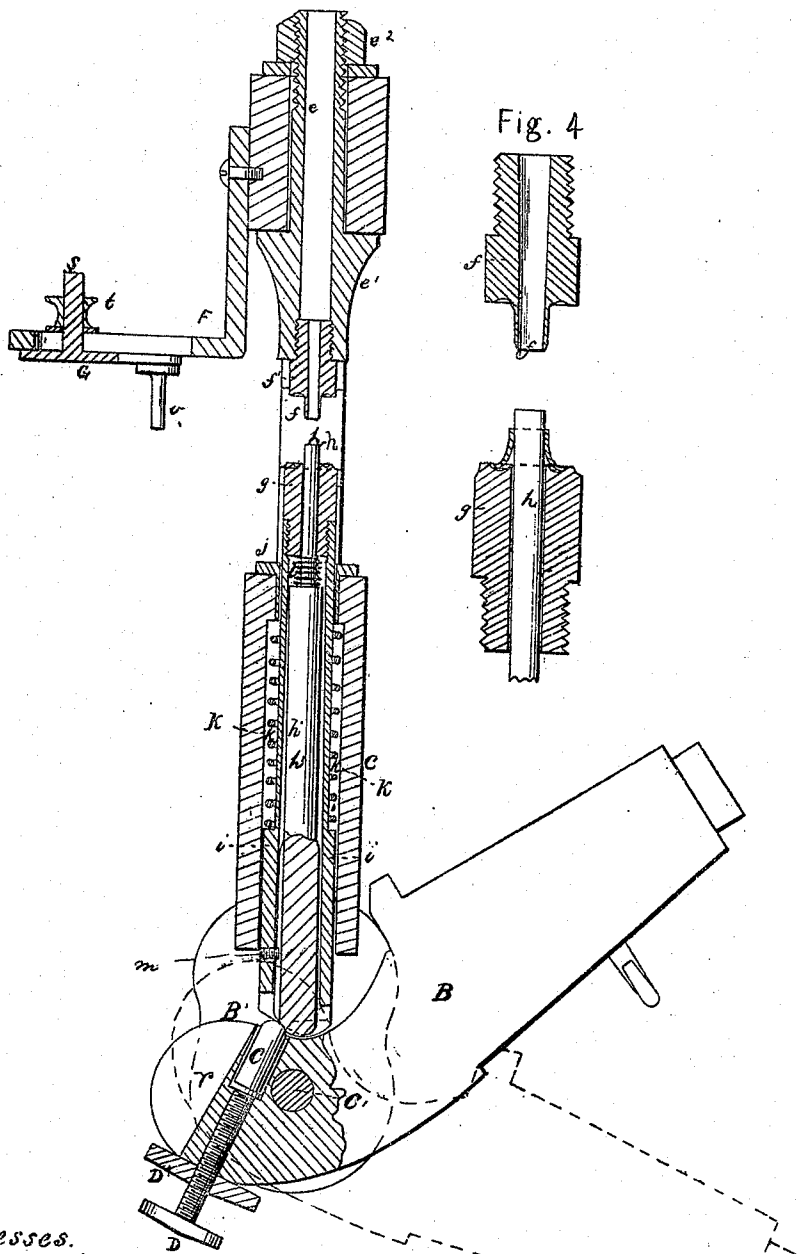

Fig. 4

Witnesses.
R. F. Campbell
Edw. Schafer

Inventor
H. Juge
by agly
Mason Fenwick Lawrence

Henry Juge. Eyeletting Machine.

N^o 63,904.

Patented Apr. 16. 1867.

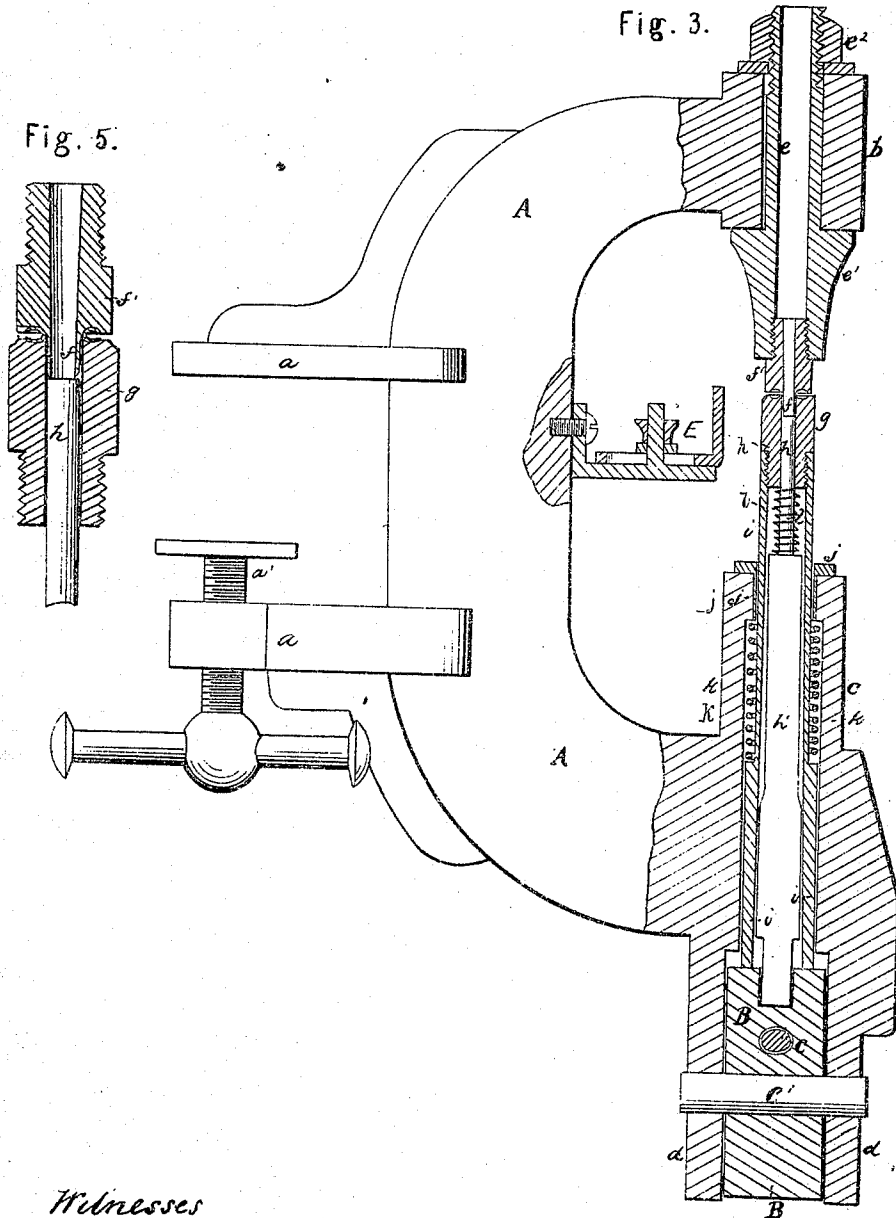

Witnesses
R. J. Campbell
Edw. Schafer

Inventor
H. Juge
by agly
Marion Finnick & Lawrence

United States Patent Office.

HENRI JUGE, OF NEW YORK, N. Y., ASSIGNOR TO HIMSELF AND THOMAS
H. ROCKWELL, OF SAME PLACE.

Letters Patent No. 63,904, dated April 16, 1867.

IMPROVEMENT IN EYELETING MACHINES.

The Schedule referred to in these Letters Patent and making part of the same.

TO ALL WHOM IT MAY CONCERN:

Be it known that I, HENRI JUGE, of New York city, county and State of New York, have invented a new and improved Eyelet-Inserting Machine; and I do hereby declare that the following is a full, clear, and exact description thereof, reference being had to the accompanying drawings, making a part of this specification, in which—

Figure 1 is a perspective view of the improved eyelet-inserting machine complete.

Figure 2 is a vertical transverse section through the working parts of the machine in position for receiving an eyelet.

Figure 3 is a vertical section taken in a plane at right angle to the plane of the section of fig. 2, showing the parts in the act of clinching an eyelet.

Figures 4 and 5 are enlarged sectional views showing the perforating and clinching devices in two positions.

Similar letters of reference indicate corresponding parts in the several figures.

This invention relates to certain novel improvements on devices which are designed for the insertion and clinching of eyelets in cloth, leather, paper, and other substances. The invention consists mainly in combining, with the devices which turn over and clinch the edges of eyelets, a tubular cutter or punch, which will cut holes through leather, cloth, and other like substances, previously to the insertion of the eyelets, and which will, at the same time, serve as a central guide for receiving the eyelets and holding them while being clinched, as will be hereinafter described. Another part of my invention consists in the employment, in conjunction with a cutting and clinching device, of an adjustable stud for gauging the spaces between the eyelets while inserting them in the substance, so that the eyelets can be inserted at regular distances apart without previously spacing off the substance which is to receive them, as will be hereinafter described.

To enable others skilled in the art to understand my invention, I will describe its construction and operation.

The frame which supports the perforating and clinching devices, and the parts which are used for operating these devices, consists of a C-shaped plate, A, having projecting jaws, *a a*, on its back, through one of which jaws an adjusting screw, *a'*, is tapped, by which the frame can be clamped firmly to the edge of a table or other fixed object. The upper end of the frame A has a hollow cylindrical enlargement, *b*, formed on it; the axis of which coincides with the axis of a longer tubular enlargement, *c*, which is formed on the lower end of the frame A, as shown in figs. 1, 2, and 3. The lower end of the tubular enlargement *c* terminates in two ears, *d d*, between which the cam-lever B is pivoted by a pin, *e'*. Through the tubular holder *b* a hollow stem, *e*, of a tapering collar, *e'*, passes and receives upon its upper end a nut, *e''*, which confines the collar *e'* firmly in place upon the lower end of the holder *b*. The hole which is made through the holder *b* may be somewhat larger than the tube or stem *e* of the collar *e'*, so as to admit of this collar being adjusted and set exactly in the centre of the device which is arranged below it for receiving the eyelets. Into the lower end of the collar *e'* the die, which spreads and clinches the upper ends of the eyelets, is screwed. This device has an annular depression formed in its lower end, and from its centre projects a tube, *f*, the lower end of which is sharpened for cutting holes through cloth, leather, or paper. This tubular cutter or punch *f* may be formed on the die *f''*, or it may be made separate and screwed therein. It may be made slightly tapering so as to commence spreading the upper end of the eyelet as soon as received thereon, as shown in fig. 5. Beneath the punch and die, above described, is a die or clinching head, *g*, which has a central hole through it through which a cylindrical stem or eyelet-holder, *h*, passes freely. This tubular clinching head *g* is screwed into the upper end of a tube, *i*, which moves up and down in the holder *e*, and is guided at its upper end by a flanged collar, *j*, which is secured to the upper end of portion *e*, as shown in figs. 2 and 3. The lower end of this tube *i* is slotted and rounded, as shown in fig. 2, and sustained upon the slotted cam-head B' of lever B. This tube *i* is forced down upon the cam-surface of head B' by a coiled spring, *k*, which will yield and allow the head *g* to be moved up to the position shown in fig. 3, by depressing the lever B, as indicated in dotted lines, fig. 2. When this lever B is released the spring *k* will move the parts *i* and B to the position shown in fig. 2. Within the tube *i* is a rod, *h'*, carrying on its upper end the stem *h* and a spring, *l*, and receiving in a vertical slot, which is formed in it near its lower end, a guide-pin, *m*, which prevents it from turning in the tube *i*. The lower end of the rod *h'* is bevelled, and held down by spring

l upon the head *B'* of lever *B*, as shown in fig. 2. *C* represents a pin which is inserted into a hole made in the upper surface of the cam-head *B'*, and adjusted so as to project more or less from said head, as may be desired, by means of a set-screw, *D*, to which a jam-nut *D'* is applied. When lever *B* is depressed the projecting end of pin *C*, which end is slightly rounded, as shown in fig. 2, will raise the rod *h'* and its pin *h* until the upper flat end of this pin touches the cutting edge of the tubular punch *f*, after which the pin *h'* and its stem will be released from upward pressure by its lower end passing into the slot *r* of the cam-head *B'*. This will allow the lower clinching head *g* to be moved up to the upper clinching head *f'*, as shown in fig. 3, by a further descent of the lever *B*. It will be seen, by reference to figs. 1, 2, and 3, that the cam-head *B'* elevates the tube *i* with its clinching head *g*, and the adjustable pin *C* elevates the stem *h'* and its pin *h*. The pin *h* will thus act in conjunction with the tubular cutter *f* so as to allow this cutter to make the holes through the substance into which it is desired to insert the eyelets, and also allow the lower clinching head *g* to insert the eyelet through the hole made in the substance, and at the same time deliver the eyelet upon the tubular cutter, after which the eyelet is clinched by and between the two heads *f'* and *g*, as shown in figs. 3 and 5. Thus it will be seen that at every descent of lever-arm *B* a hole is made through the leather or cloth, the eyelet inserted, and then firmly clinched.

I am aware that tapering punches have been used for introducing eyelets through cloth, in conjunction with clinching heads, but such punches are objectionable, particularly for inserting eyelets in leather, as they do not cut out the leather and thus leave a hole for receiving the eyelet. I do not therefore lay claim to solid punches of a tapering form.

Directly behind the perforating and clinching devices an adjustable gauge, *E*, is applied, which consists of a slotted plate with its front end turned up, which plate is secured by a set-screw to a shelf that is secured firmly to the front edge of frame *A*, as shown in fig. 3. This gauge *E* is used for allowing the eyelets to be inserted at a uniform distance from the edge of a piece of cloth, and in a line parallel thereto. On one side of the enlarged head *b* a right-angular plate, *F*, is secured, the horizontal portion of which is slotted, as shown in fig. 2, for receiving through it a screw-stud, *s*, which is formed on an adjustable plate, *G*. This stud *s* receives upon it a thumb-screw or nut, *t*, by which plate *G* can be firmly clamped to plate *F*, as shown in figs. 1 and 2. A stud, *v*, projects perpendicularly from plate *G* and serves to receive an eyelet which has been inserted into a piece of cloth, so as to determine the distance from such eyelet for the insertion of another. By means of this gauge-pin the cloth is not only held in place, but it is held in the desired position for the insertion of other eyelets, thereby having the eyelets at regular distances apart. By loosening the thumb-screw *t* the pin or stud *v* can be set at any required distance from the hollow punch *f*.

The operation of inserting eyelets is as follows:

The gauges *E* and *v* are properly adjusted and secured. An eyelet is slipped over the projecting end of pin *h*, with its smallest end uppermost, as shown in fig. 4. The cloth which is to receive this eyelet is adjusted beneath the punch *f*, and the lever *B* depressed, either by hand, or by a treadle. The first movement of lever *B* brings pin *h* up closely against the punch *f* and cuts the hole. The second movement of this lever raises the clinching head *g* and inserts the eyelet through the hole made in the cloth, and at the same time delivers the eyelet upon the punch *f*, which latter receives the head *g*. The final movement of said lever brings the head *g* sufficiently close to the head *f'* to clinch the eyelet. When lever *B* is released the parts will fall back to the positions shown in fig. 2. This operation is repeated for every eyelet which is inserted into the fabric, the last eyelet being the one placed over the pin *v*, thus having them at regular distances apart.

What I claim as new, and desire to secure by Letters Patent, is—

1. An eyelet-clinching head, having a tubular punch, or cutter, *f*, applied to it, in combination with a perforated clinching head, having a pin, *h*, through it, said parts being arranged and operated so as to cut a hole through cloth or other substances, insert and clinch an eyelet at one operation, substantially as described.

2. The clinching head *f'*, provided with a tubular cutting punch, *f*, substantially as and for the purposes set forth.

3. In combination with eyelet-punching and clinching devices, constructed substantially as described, I claim the movable tube *i*, and movable stem *h h'*, with their springs *k l* and cam-lever *B*, arranged so that they shall operate substantially as described.

4. The adjustable pin *C*, applied to the cam-head *B'* of lever *B*, for moving the stem *h h'*, substantially as described.

5. In combination with the machine, constructed as herein described, I claim the adjustable gauge pin *v*, substantially as set forth.

6. In combination with the machine, constructed as herein described, I claim the adjustable gauge *E* and adjustable gauge-pin *v*, substantially as described.

HENRI JUGE.

Witnesses:

THOMAS H. ROCKWELL,
JAS. G. SWEENEY.