

J. SCHOFIELD & J. STEVENS.

LEATHER-CUTTING AND MOLDING-MACHINE.

No. 183,471.

Patented Oct. 17, 1876.

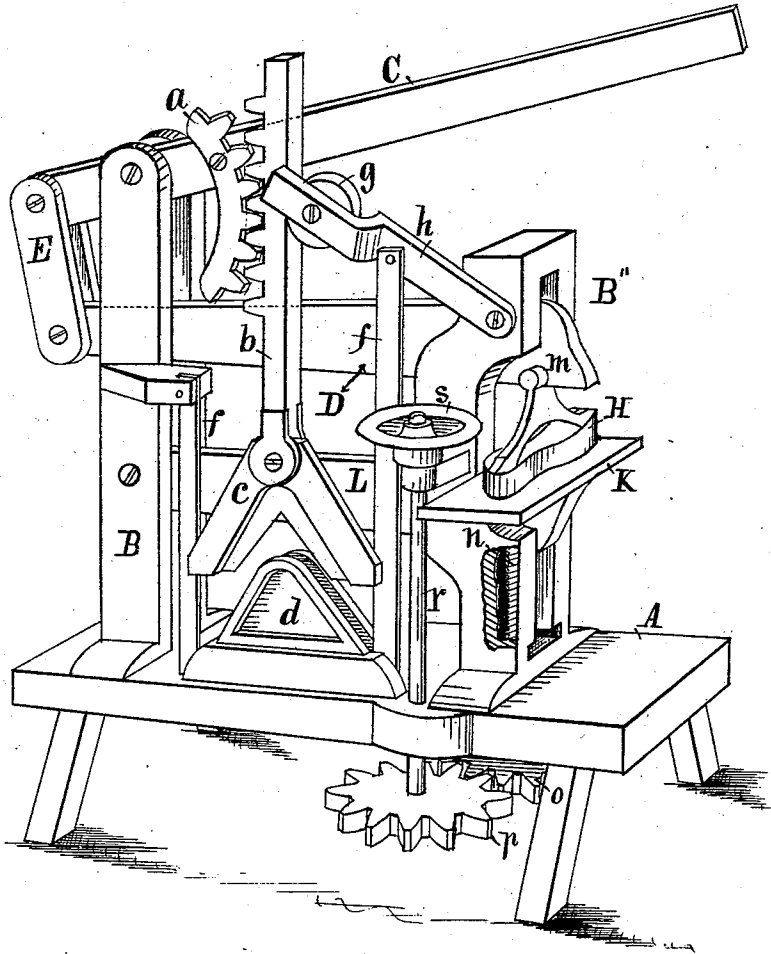

Witnesses,
Robert Massey,
Luci L. Ulrich.

Inventors,
Jacob Schofield,
Joseph Stevens,
By Thomas G. Orwig, atty.

UNITED STATES PATENT OFFICE.

JACOB SCHOFIELD AND JOSEPH STEVENS, OF NEWTON, IOWA.

IMPROVEMENT IN LEATHER CUTTING AND MOLDING MACHINES.

Specification forming part of Letters Patent No. **183,471**, dated October 17, 1876; application filed July 28, 1876.

To all whom it may concern:

Be it known that we, JACOB SCHOFIELD and JOSEPH STEVENS, of Newton, in the county of Jasper and State of Iowa, have invented a Boot and Shoe Cutting Machine, of which the following is a specification:

The object of our invention is to save time and labor in the manufacture of boots and shoes.

It consists in constructing and combining additional mechanism with our metal-cutting machine, patented April 18, 1876, No. 176,246, and thereby adapting that machine to be utilized in cutting and molding boot and shoe leather, all as hereinafter fully set forth.

Our drawing is a perspective view, illustrating the construction and operation of our improved machine.

A is the base or bench supporting the machine. It may be wood or metal, and vary in size, as required for machines differing in size and weight. B and B' represent the uprights and frame of the machine. C is the hand-lever by means of which the machine is operated. D is a lever, pivoted in the upright B', and connected with the short arm of the hand-lever C by means of a link, E. *m* is a socket formed in or attached to the under side of the short arm of the lever D. H represents a knife or die or shaping block, suspended by a handle or frame, that has its top formed to enter the socket *m* in the lever D, and to form a socket-joint therewith that will allow the suspended knife, die, or former to oscillate, and thereby maintain a perpendicular and level position during the movements of the inclined lever D, to which it is attached. K is a table or an adjustable platform, fixed to and carried by the arm L, pivoted to the upright B, and extended through the upright B'. *n* is a vertical screw, operated in bearings fixed in the upright B'. Its top end engages and supports the free end of the arm L, that carries the table K. *o* is a gear-wheel, rigidly connected with the lower end of the screw *n*. *p* is a pinion, rigidly fixed to the lower end of the vertical shaft *r*, to mate with and operate the gear-wheel *o* and the screw *n*. The shaft *r* is

supported by suitable bearings projecting from the base and frame of the machine. *s* is a hand-wheel at the top of the shaft *r*, and within reach of the operator attending the cutting or shaping dies H.

In the practical operation of our machine, movable cutters, dies, or formers H, varying in size and shape as desired, are, one at a time, connected with and suspended from the short arm of the lever D. For cutting out boot and shoe soles, uppers, or other forms, the material is placed upon the table K, and the table then adjusted relative to the lever D and the suspended cutter or die H, as required, by turning the hand-wheel *s*, and thereby operating the screw *n* by means of the gearing *o p*. When the table carrying the material to be cut is properly adjusted, the lever C can be operated by hand to sink the cutter through the material and cut out the form desired. To leave the hands of the operator free to move the dies and leather, a treadle may be connected with the lever C, so that it can be readily and advantageously operated by the foot of the attendant.

To mold and shape leather, various forms of dies or shaping-blocks H may be used, and corresponding dies or hollowed blocks secured upon the table K.

Leather and other flexible materials may be thus advantageously cut and shaped by the use of our improved machine, and much of the time and labor required to cut and shape by hand can be thereby saved.

We claim as our invention—

The screw *n*, carrying the gear-wheel *o*, and the shaft *r*, having the hand-wheel *s* and the pinion *p*, mounted upon the base A and upright B', and arranged and combined with the pivoted arm L, carrying the table K, substantially as and for the purposes shown and described.

JACOB SCHOFIELD.
JOSEPH STEVENS.

Witnesses:

JOSEPH BOWKER,
JNO. L. MATHEWS.