

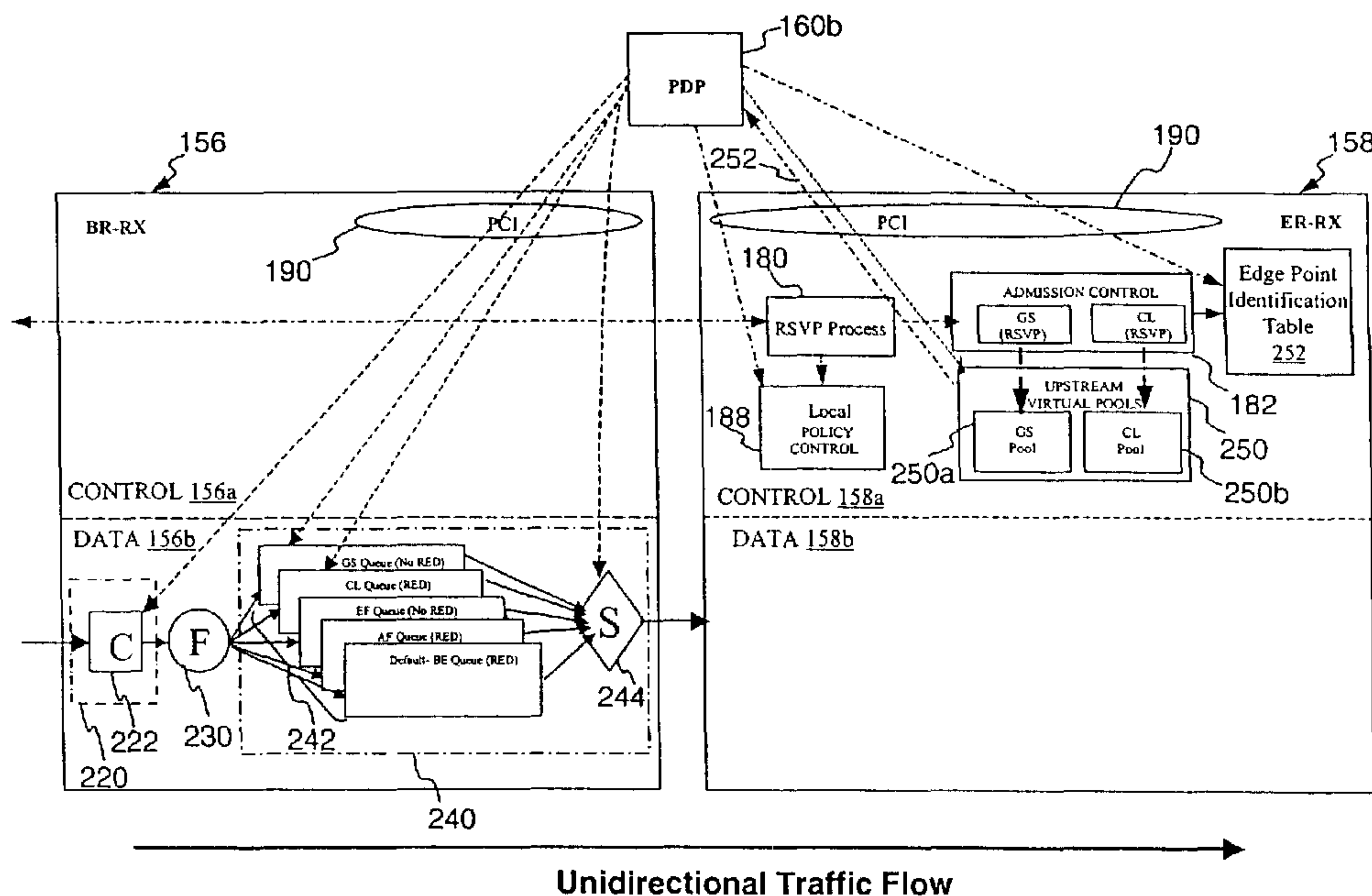

(86) Date de dépôt PCT/PCT Filing Date: 2002/03/20
 (87) Date publication PCT/PCT Publication Date: 2002/09/26
 (85) Entrée phase nationale/National Entry: 2003/09/18
 (86) N° demande PCT/PCT Application No.: US 2002/008436
 (87) N° publication PCT/PCT Publication No.: 2002/075554
 (30) Priorités/Priorities: 2001/03/20 (60/276,923) US;
 2001/03/20 (60/276,955) US; 2001/03/20 (60/276,953) US;
 2001/11/13 (60/331,271) US; 2002/03/12 (10/095,910) US

(51) Cl.Int.⁷/Int.Cl.⁷ G06F 13/00
 (71) Demandeur/Applicant:
 WORLDCOM, INC., US
 (72) Inventeurs/Inventors:
 MCDYSAN, DAVID E., US;
 RAWLINS, DIANA J., US;
 YAO, LEI, US
 (74) Agent: RIDOUT & MAYBEE LLP

(54) Titre : GESTION DES RESSOURCES BASEE SUR UN POT COMMUN DANS UN RESEAU DE DONNEES
 (54) Title: POOL-BASED RESOURCE MANAGEMENT IN A DATA NETWORK



(57) **Abrégé/Abstract:**

In one embodiment, a network system of the present invention includes at least a first router (156) and a second router (158) coupled to an upstream link to permit data flow from the first router (156) to the second router (158) across the upstream link. The second router (158) includes a control plane (158a) and a data plane (158b) having an input port coupled to the upstream link and an output port connectable to a downstream link. The control plane (158a) includes a virtual pool (250) having a capacity corresponding to a resource capacity of the first router (156) and an admission control function (182). In response to a request to reserve resources for a flow through the data plane (158b) from the input port to the output port, the admission control function (182) performs admission control for the upstream link by reference to resource availability within the virtual pool (250). In one embodiment, the request is a request to reserve resources for an Integrated Services flow, and the capacity of the virtual pool (250) corresponds to a resource capacity of a Integrated Services service class supported by the first router (156).

(12) INTERNATIONAL APPLICATION PUBLISHED UNDER THE PATENT COOPERATION TREATY (PCT)

(19) World Intellectual Property Organization
International Bureau



(43) International Publication Date
26 September 2002 (26.09.2002)

PCT

(10) International Publication Number
WO 02/075554 A1

(51) International Patent Classification⁷: G06F 13/00

318 Northview Drive, Richardson, TX 75080 (US). YAO, Lei; 2000 South Eads Street #517, Arlington, VA 22202 (US).

(21) International Application Number: PCT/US02/08436

(22) International Filing Date: 20 March 2002 (20.03.2002)

(74) Agent: GROLZ, Edward, W.; Scully, Scott, Murphy & Presser, 400 Garden City Plaza, Garden City, NY 11530 (US).

(25) Filing Language: English

(26) Publication Language: English

(30) Priority Data:
60/276,923 20 March 2001 (20.03.2001) US
60/276,953 20 March 2001 (20.03.2001) US
60/276,955 20 March 2001 (20.03.2001) US
60/331,271 13 November 2001 (13.11.2001) US
10/095,910 12 March 2002 (12.03.2002) US

(81) Designated States (national): AE, AG, AL, AM, AT, AU, AZ, BA, BB, BG, BR, BY, BZ, CA, CH, CN, CO, CR, CU, CZ, DE, DK, DM, DZ, EC, EE, ES, FI, GB, GD, GE, GH, GM, HR, HU, ID, IL, IN, IS, JP, KE, KG, KP, KR, KZ, LC, LK, LR, LS, LT, LU, LV, MA, MD, MG, MK, MN, MW, MX, MZ, NO, NZ, OM, PH, PL, PT, RO, RU, SD, SE, SG, SI, SK, SL, TJ, TM, TN, TR, TT, TZ, UA, UG, UZ, VN, YU, ZA, ZM, ZW.

(84) Designated States (regional): ARIPO patent (GH, GM, KE, LS, MW, MZ, SD, SL, SZ, TZ, UG, ZM, ZW), Eurasian patent (AM, AZ, BY, KG, KZ, MD, RU, TJ, TM), European patent (AT, BE, CH, CY, DE, DK, ES, FI, FR, GB, GR, IE, IT, LU, MC, NL, PT, SE, TR), OAPI patent (BF, BJ, CF, CG, CI, CM, GA, GN, GQ, GW, ML, MR, NE, SN, TD, TG).

(71) Applicant: WORLDCOM, INC. [US/US]; 500 Clinton Center Drive, Clinton, MS 39056 (US).

(72) Inventors: McDYSAN, David, E.; 2159 Astoria Circle, #104, Herndon, VA 20170 (US). RAWLINS, Diana, J.;

[Continued on next page]

(54) Title: POOL-BASED RESOURCE MANAGEMENT IN A DATA NETWORK

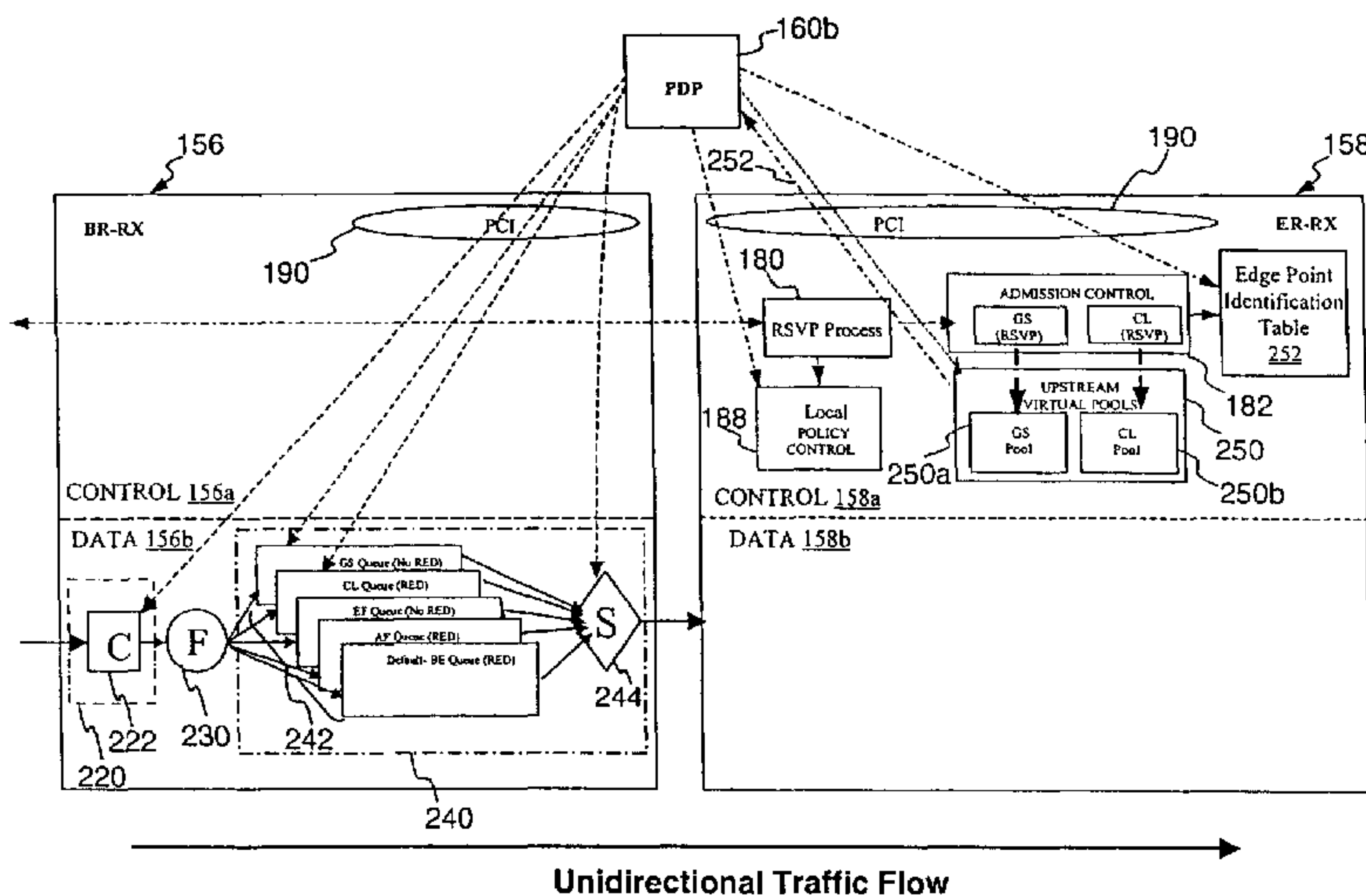

(57) Abstract: In one embodiment, a network system of the present invention includes at least a first router (156) and a second router (158) coupled to an upstream link to permit data flow from the first router (156) to the second router (158) across the upstream link. The second router (158) includes a control plane (158a) and a data plane (158b) having an input port coupled to the upstream link and an output port connectable to a downstream link. The control plane (158a) includes a virtual pool (250) having a capacity corresponding to a resource capacity of the first router (156) and an admission control function (182). In response to a request to reserve resources for a flow through the data plane (158b) from the input port to the output port, the admission control function (182) performs admission control for the upstream link by reference to resource availability within the virtual pool (250). In one embodiment, the request is a request to reserve resources for an Integrated Services flow, and the capacity of the virtual pool (250) corresponds to a resource capacity of a Integrated Services service class supported by the first router (156).

WO 02/075554 A1

WO 02/075554 A1



Published:

— *with international search report*

For two-letter codes and other abbreviations, refer to the "Guidance Notes on Codes and Abbreviations" appearing at the beginning of each regular issue of the PCT Gazette.

- 1 -

POOL-BASED RESOURCE MANAGEMENT IN A DATA NETWORK

[01] The present invention relates to communication networks and, in particular, providing an enhanced quality of service (QoS) to selected traffic flows within a network.

[02] For network service providers, a key consideration in network design and management is the appropriate allocation of access capacity and network resources between traffic originating from network service customers and traffic originating from outside the service provider's network (e.g., from the Internet). This consideration is particularly significant with respect to the traffic of network customers whose subscription includes a Service Level Agreement (SLA) requiring the network service provider to provide a minimum communication bandwidth or to guarantee a particular Quality of Service (QoS) for certain flows. Such service offerings require the network service provider to implement a network architecture and protocol that achieve a specified QoS and that enforce admission control to ensure sufficient access capacity and network resources are available for customers.

[03] In Internet Protocol (IP) networks, a straightforward approach to achieving QoS and implementing admission control comparable to that of connection-oriented network services, such as voice or Asynchronous Transfer Mode (ATM), is to emulate the same hop-by-hop switching paradigm of signaling resource reservations for the flow of IP packets requiring QoS. In fact, the IP signaling standard developed by the Internet Engineering Task Force (IETF) for Integrated Services (Intserv or IS) adopts precisely this approach. As described in IETF RFC 1633 [R. Branden et al., "Integrated Services in the Internet Architecture: an Overview" June 1994], Intserv is a per-flow IP QoS architecture that enables applications to choose among multiple, controlled levels of delivery service for their data packets. To support this capability, Intserv permits an application at a transmitter of a packet flow to use the well-known Resource ReSerVation Protocol (RSVP) defined by IETF RFC 2205 [R. Branden et al., "Resource ReSerVation Protocol (RSVP) - Version 1 Functional

- 2 -

Specification" Sept. 1997] to initiate a flow that receives enhanced QoS from network elements along the path to a receiver of the packet flow.

[04] RSVP is a QoS signaling protocol on the control plane of network devices that is utilized to request resources for a simplex flows (i.e., RSVP requests resources for a unidirectional flow). RSVP does not have routing functions, but is instead designed to operate with unicast and multicast routing protocols to ensure QoS for those packets that are forwarded in accordance with routing (i.e., RSVP consults the forwarding table (as populated by routing) in order to decide the downstream interface on which policy and admission control for QoS are applied).

[05]. **Figure 1** is a block diagram of an Intserv nodal processing model that utilizes RSVP to achieve QoS in accordance with RFC 2205. As illustrated, a transmitting host **100** executes an application **104**, which transmits data (e.g., video distribution or voice-over-IP (VoIP)) that requires a higher QoS than the "best effort" QoS generally accorded Internet traffic. Between transmitting host **100** and a receiving host **118** are coupled one or more additional nodes, such as router **102**, which implements a routing process **116**.

[06] In the control plane, each network node includes an RSVP process **106** that supports inter-node communication of RSVP messages, a policy control block **108** that determines if a user has administrative permission to make a resource reservation for an enhanced QoS flow, and an admission control block **110** that determines whether or not the node has sufficient outgoing bandwidth to supply the requested QoS. In the data plane, each node further includes a packet classifier **112**, which identifies packets of a flow and determines the QoS class for each packet, and a packet scheduler **114**, which actually achieves the QoS required for each flow in accordance with the packet classification performed by packet classifier **112**.

[07] To initiate an RSVP session, application **104** transmits a PATH message, which is sequentially passed to the RSVP process **106** at each node between transmitting host **100** and

- 3 -

receiving host 118. Although transmitting host 100 initiates the RSVP session, receiving host 118 is responsible for requesting a specified QoS for the session by sending a RESV message containing a QoS request to each network node along the reverse path between receiving host 118 and transmitting host 100. In response to the receipt of the RESV message, each RSVP process 106 passes the reservation request to its local policy control module 108 and admission control block 110. As noted above, policy control block 108 determines whether the user has administrative permission to make the reservation, and admission control block 110 determines whether the node has sufficient available resources (i.e., downstream link bandwidth) to supply the requested QoS. If both checks succeed at all nodes between transmitting host 100 and receiving host 118, each RSVP process 106 sets parameters in the local packet classifier 112 and packet scheduler 114 to obtain the desired QoS, and RSVP process 106 at transmitting host 100 notifies application 104 that the requested QoS has been granted. If, on the other hand, either check fails at any node in the path, RSVP process 106 at transmitting host 100 returns an error notification to the application 104.

[08] Although conceptually very simple, Intserv QoS provisioning has limited scalability because of the computationally intensive RSVP processing that is required at each network node. In particular, RSVP requires per-flow RSVP signaling, per-flow classification, per-flow policing/shaping, per-flow resource management, and the periodic refreshing of the soft state information per flow. Consequently, the processing required by Intserv RSVP signaling is comparable to that of telephone or ATM signaling and requires a high performance (i.e., expensive) processor component within each IP router to handle the extensive processing required by such signaling.

[09] In recognition of the scalability and other problems associated with implementing IP QoS utilizing conventional Intserv RSVP signaling, the IETF promulgated the Differentiated Services (Diffserv or DS) protocol defined in RFC 2475 [S. Blake et al., "An Architecture for Differentiated Services" Dec. 1998]]. Diffserv is an IP QoS architecture that achieves

- 4 -

scalability by conveying an aggregate traffic classification within a DS field (e.g., the IPv4 Type of Service (TOS) byte or IPv6 traffic class byte) of each IP-layer packet header. The first six bits of the DS field encode a Diffserv Code Point (DSCP) that requests a specific class of service or Per Hop Behavior (PHB) for the packet at each node along its path within a Diffserv domain.

[10] In a Diffserv domain, network resources are allocated to packet flows in accordance with service provisioning policies, which govern DSCP marking and traffic conditioning upon entry to the Diffserv domain and traffic forwarding within the Diffserv domain. The marking and conditioning operations need be implemented only at Diffserv network boundaries. Thus, rather than requiring end-to-end signaling between the transmitter and receiver to establish a flow having a specified QoS, Diffserv enables an ingress boundary router to provide the QoS to aggregated flows simply by examining and/or marking each IP packet's header.

[11] As described in RFC 2998 [Y. Bernet et al., "A Framework for Integrated Services Operation over Diffserv Networks" Nov. 2000] and as illustrated in **Figure 2**, Integrated Services can be implemented over a Differentiated Services domain. In the network model illustrated in **Figure 2**, edge routers (ERs) **120**, **128** connect Integrated Services-aware customer LANs (not shown) to boundary routers (BRs) **122**, **126** of a Diffserv network **124**. To reflect a unidirectional traffic flow from LAN-TX (transmitting) to LAN-RX (receiving), edge router **120** and boundary router **122** are labeled ER-TX and BR-TX, respectively, at the transmitter or ingress side, and edge router **128** and boundary router **126** are labeled ER-RX and BR-RX, respectively, at the receiver or egress side.

[12] Viewed logically, each of routers **120**, **122**, **126** and **128** has control and data planes, which are respectively depicted in the upper and lower halves of each router. The data plane includes all of the conventional hardware components in the forwarding path of the router (e.g., interface cards and switching fabric), and the control plane includes control hardware

- 5 -

(e.g., a control processor) and control software (e.g., routing, signaling and protocol stacks) that support and direct the operation of the data plane.

[13] In the data plane, packets are marked by data plane 120b of ER-TX 120 with the appropriate DSCP (e.g., based upon the Intserv 5-tuple of source address, destination address, protocol id, source port and destination port) and forwarded to Diffserv network 124. The packets are then solely Diffserv forwarded across Diffserv network 124 to data plane 128b of ER-RX 128. In the control plane, each of edge routers 120, 128 and boundary routers 122, 126 has a control plane that performs Intserv (IS) processing by reference to policies implemented in policy decision points (PDPs) 130a, 130b. In ER-TX 120, control plane 120a performs Intserv per-flow classification and per-flow policing. In boundary routers 122 and 126, the Intserv interfaces facing edge routers 120, 128 manage RSVP signaling, perform Intserv policy and admission control functions, and maintain in per-flow state with path state blocks and reservation state blocks. Control plane 128a of ER-RX 128 performs Intserv per-flow shaping before outgoing packets are forwarded to LAN -RX.

[14] As discussed above, before sending a traffic flow, a transmitting host in LAN-TX initiates a RSVP PATH message. When the receiving host in LAN-RX receives the PATH message, the receiving host returns a RESV message along the reverse data path to request reservation of resources to provide the desired QoS. After receiving the RESV message, each intermediate router having an Intserv control plane performs admission control for only its downstream link. Thus, ER-RX 128 performs admission control for LAN-RX, BR- RX 126 performs admission control for the link between itself and ER-RX 128, BR-TX 122 performs admission control for the path across Diffserv network 124 to BR-RX 126, and ER-TX 120 performs admission control for the link between itself and BR -TX 122. The RSVP admission control process verifies resource availability on each link and accordingly adjusts the remaining resource count for the link.

- 6 -

[15] Although Intserv per-flow admission control is performed on the control plane, the actual delivery of QoS for a traffic flow is accomplished on the data plane. ER-TX 120 performs Intserv operations (i.e., per-flow classification, per-flow policing, and per-flow DSCP marking) on data packets received at its Intserv input interface (IS IN). At the Diffserv output interface (DS OUT) of ER-TX 120, data packets are identified and class-based queued based on only their DSCP values. BR-TX 122 then performs per-class policing for each customer at its input interface (DS IN) and class-based queuing at its output interface (DS OUT). At BR-RX 126, no operation is performed at the input interface (DS IN), and class-based queuing and optionally per-class shaping are performed for each customer port at the output interface. ER-RX 128 forwards packets received at its input interface (DS IN) and may perform per-flow scheduling or shaping at its Intserv output interface (IS OUT).

[16] Although the Diffserv standard improves upon Intserv's scalability by replacing Intserv's processing-intensive signaling in the Diffserv domain with a simple class-based processing, implementation of the Diffserv protocol introduces a different problem. In particular, because Diffserv allows host marking of the service class, a Diffserv network customer link (e.g., the outgoing link of BR-RX 126) can experience a Denial of Service (DoS) attack if a number of hosts send packets to that link with the DS field set to a high priority.

[17] Furthermore, despite some improvements in scalability within the Diffserv domain, Intserv admission control utilizing RSVP still requires per-flow state installation, per-flow state refreshment, per-flow traffic management and resource reservation on each edge and boundary router of a service provider's networks. Because boundary routers process thousands of traffic flows as network aggregation points, many vendors' boundary routers cannot install flow state for such a large number of flows. As a result, RSVP per-flow admission control has been rarely implemented and supported by router vendors. Thus,

- 7 -

conventional Intserv per-flow admission control using RSVP remains undesirable due to its lack of scalability.

[18] The present invention addresses the foregoing and additional shortcomings in the prior art by introducing an improved method, apparatus and system for performing admission control.

[19] In accordance with one embodiment of the invention, a network system of the present invention includes at least a first router and a second router coupled to an upstream link to permit data flow from the first router to the second router across the upstream link. The second router includes a control plane and a data plane having an input port coupled to the upstream link and an output port connectable to a downstream link. The control plane includes a virtual pool having a capacity corresponding to a resource capacity of the first router and an admission control function. In response to a request to reserve resources for a flow through the data plane from the input port to the output port, the admission control function performs admission control for the upstream link by reference to resource availability within the virtual pool. In one embodiment, the request is a request to reserve resources for an Integrated Services flow, and the capacity of the virtual pool corresponds to a resource capacity of a Integrated Services service class supported by the first router.

[20] Additional objects, features, and advantages of the present invention will become apparent from the following detailed written description.

[21] The novel features believed characteristic of the invention are set forth in the appended claims. The invention itself however, as well as a preferred mode of use, further objects and advantages thereof, will best be understood by reference to the following detailed description of an illustrative embodiment when read in conjunction with the accompanying drawings, wherein:

- 8 -

[22] **Figure 1** depicts a conventional Integrated Services (Intserv) nodal processing model in which per-flow QoS is achieved utilizing RSVP signaling in accordance with RFC 2205;

[23] **Figure 2** illustrates a conventional network model in which Integrated Services (Intserv) are implemented over a Differentiated Services (Diffserv) domain in accordance with RFC 2998;

[24] **Figure 3** is a high-level network model that, in accordance with a preferred embodiment of the present invention, implements Intserv over a Diffserv domain while eliminating Intserv processing in the boundary routers of the Diffserv domain;

[25] **Figure 4** illustrates one method by which the receiving edge router of a traffic flow can be identified within the network model of **Figure 3**;

[26] **Figure 5** is a more detailed block diagram of a transmitting edge router in accordance with a preferred embodiment of the present invention;

[27] **Figure 6** is a more detailed block diagram of a receiving boundary router and receiving edge router in accordance with a preferred embodiment of the present invention;

[28] **Figure 7** is a block diagram of an exemplary server computer system that may be utilized to implement a Policy Decision Point (PDP) in accordance with a preferred embodiment of the present invention;

[29] **Figure 8A** depicts a preferred method of installing policies on a receiving boundary router and receiving edge router during service initialization;

[30] **Figure 8B** illustrates a preferred method of installing policies on a receiving boundary router and receiving edge router in response to a service update; and

- 9 -

[31] **Figure 8C** depicts a preferred method of policy synchronization following a direct service update to a receiving boundary router.

I. Network Model Overview

[32] With reference again to the figures and, in particular, with reference to **Figure 3**, there is depicted a high level block diagram of an scalable network model that provides enhanced QoS to selected traffic by implementing edge-based Intserv over a Diffserv domain in accordance with the present invention. Specifically, as described in detail below, the illustrated network model improves network scalability by eliminating Intserv per-flow admission control from network devices in the Diffserv domain using a mechanism that maps per-flow bandwidth requirements to class-based resource pools for resource reservation and management. For ease of understanding, **Figure 3** employs the same receiver/transmitter and data plane/control plane notation utilized in **Figure 2**.

[33] In **Figure 3**, Integrated Services-aware LAN-TX and LAN-RX, which may each contain one or more hosts, are connected to customer premises equipment (CPE) edge routers (ERs) **150, 158**. Edge routers **150, 158** are in turn coupled by access networks (e.g., L2 access networks) to boundary routers (BRs) **152, 156** of Diffserv network **124**. The network service provider configures routers **150, 152, 156** and **158** and installs admission control and other policies on **150, 152, 156** and **158** utilizing one or more PDPs **160**.

[34] Utilizing this configuration, the network model of **Figure 3** supports unidirectional traffic flow from transmitting hosts in LAN-TX to receiving hosts in LAN-RX. As is typical, such communication is preferably conducted utilizing a layered protocol architecture in which each protocol layer is independent of the higher layer and lower layer protocols. In one preferred embodiment, communication employs the well-known Internet Protocol (IP) at the network level, which corresponds to Layer 3 of the ISO/OSI (International Organization for Standardization/Open Systems Interconnect) reference model. Above the network layer,

-10-

communication may employ TCP (Transmission Control Protocol) or UDP (User Datagram Protocol) in the transfer layer corresponding to Layer 4 of the OSI/ISO reference model.

[35] Above the transfer layer, communication may employ any of a number of different protocols, as determined in part by the required QoS and other requirements of a flow. For example, the International Telecommunication Union (ITU) H.323 protocol and the IETF Session Initiation Protocol (SIP) are commonly utilized to provide signaling for voice, video, multimedia and other types of enhanced QoS sessions over an IP network. As an end-to-end protocol, SIP advantageously permits the end nodes with the capability to control call processing utilizing various call features (e.g., Find-me/Follow-me).

[36] In contrast to the prior art network model illustrated in **Figure 2**, which requires an Intserv control plane that performs Intserv processing in at least each edge and Diffserv boundary router, the network model illustrated in **Figure 2** employs Intserv processing only at the extreme edge of the network, that is, on network-managed CPE edge routers **150, 158**. Thus, for the illustrated unidirectional packet flow, edge routers **150, 158** perform Intserv admission control utilizing RSVP signaling to provide enhanced QoS for a flow sent from LAN-TX to LAN-RX. Because edge routers **150, 158** perform Intserv admission control for Diffserv network **154** (and assuming that Diffserv network **154** has been well traffic engineered), there is no need to implement any additional admission control for Diffserv network **154**. Consequently, in accordance with the present invention, none of the routers in Diffserv network **154**, including boundary routers **152, 156** and unillustrated core routers, is required to have an Intserv control plane, as indicated at reference numerals **152a** and **156a**. Consequently, boundary routers **152** and **156** can be significantly simplified to promote enhanced scalability of the service provider network.

[37] To achieve this advantageous simplification in boundary routers **152, 156**, the network model of **Figure 3** implements modifications to the conventional Intserv RSVP signaling model, which, as described above, always performs symmetric processing at each

-11-

node to perform admission control for the downstream link. In the network model illustrated in **Figure 3**, the RSVP RESV message returned by the receiving host is processed only by the Intserv control planes **150a**, **158a** of edge routers **150**, **158**, which verify the availability of the requested resources and adjust resource counts accordingly. In particular, Intserv control plane **150a** of ER-TX **150** performs downstream admission control for the link between itself and BR-TX **152**. Intserv control plane **158a** of ER-RX **158**, however, performs admission control not only for its downstream link (i.e., LAN-RX), but also for the upstream link itself and BR-RX **156** because boundary routers **152**, **156** are not RSVP-aware.

[38] Although conceptually elegant, this network model shown in **Figure 3** has a number of non-trivial challenges that must be addressed in order to obtain operative network implementations. For example, because conventional Intserv RSVP signaling is symmetrical at each node, no conventional mechanism is provided to inform ER-RX **156** that it is the "receiving" edge router and must therefore perform admission control for its upstream link. In addition, conventional Intserv RSVP signaling does not provide ER-RX **156** with any information regarding the resource capacity and resource availability of the upstream link for which admission control must be performed. Moreover, RFC 2998 (and the art generally) does not provide any guidance regarding how to implement Diffserv/Intserv interworking at ER-TX **150** and, in particular, does not disclose how to map Intserv classes to Diffserv classes. Preferred solutions to these and other issues concerning an implementation of the network model shown in **Figure 3** are described in detail below.

II. Receiving Edge Router Identification

[39] Referring now to **Figure 4**, there is depicted one preferred method by which an edge router, such as ER-RX **158**, can determine that it is the receiving edge router. In the depicted operating scenario, each of the customer LANs, edge routers **150**, **158** and boundary routers **152**, **156** has a different IP address, and the customer LANs coupled to ER-RX **158** are each assigned an IP address that is a subnet of the IP address assigned to ER-RX **158**.

-12-

[40] As noted above, a transmitting host in LAN-TX initiates an enhanced QoS session with a receiving host in LAN-RX by transmitting an RSVP PATH message. Based upon the destination address (DestAddress) specified in the PATH message, which in the illustrated example is a.b.p.d, the PATH message is routed to across Diffserv network 154 to LAN-RX. In response to the PATH message, the receiving host transmits an RSVP RESV message containing a SESSION object that specifies the destination address. Upon receipt of the RESV message, the RSVP process in Intserv control plane 158a of ER-RX 158 can determine whether ER-RX 158 is the receiving edge router by comparing the destination address with the IP subnet address of each attached customer LANs. If and only if the destination address falls into one of its attached customer subnets, ER-RX 158 "knows" it is the receiving edge router for the traffic flow. For example, when ER-RX 158 receives a RESV message having a SESSION object containing destination address a.b.p.d, ER-RX 158 knows that it is the receiving edge router since the IP address of LAN -RX (i.e., a.b.p.d) is an IP subnet address of a.b.p.0/24. ER-RX 158 therefore performs Intserv admission control for its upstream link for the enhanced QoS flow.

[41] Although this method of identifying the receiving edge router has the advantage of simplicity, it requires that each destination address specify a subnet of the receiving edge router's IP address. In implementations in which this restriction is not desirable, alternative methods of identifying the receiving edge router may be employed. For example, as described below in detail with respect to Figure 6, the receiving edge router may alternatively be identified through an Edge Point Identification table configured on edge routers 150, 158 by PDPs 160. These policy data structures specify one or more ranges of IP addresses for which a router is the receiving edge router.

III. Resource Management

[42] To track resource availability (including the resource availability utilized to perform upstream admission control), each Intserv-aware edge router maintains a separate or shared virtual pool in its control plane for each Intserv class, where each virtual pool represents the resource availability for the associated Intserv class(es) on a link for which the router performs admission control. Whenever an edge router receives an RSVP RESV message, the edge router performs admission control on the link by checking the requested bandwidth against the appropriate virtual pool to determine resource availability in the requested Intserv class. If the virtual pool indicates the requested bandwidth is less than the available bandwidth, the reservation request is approved and the reservable resources of virtual pool are reduced by the amount of reserved bandwidth. If, however, the requested bandwidth exceeds the virtual pool's available bandwidth the QoS request is denied.

[43] Interworking between the Intserv admission control and Diffserv data plane functions is achieved by association of the virtual pools utilized to perform Intserv admission control with the logical queues employed by Diffserv to deliver class-based QoS on the data plane. In particular, each Intserv class is uniquely associated with one and only one Diffserv logical queue. However, like the virtual pools utilized to perform Intserv admission control, a separate logical queue can be implemented for each of one or more Intserv classes, and one or more logical queues may be implemented as shared queues that are associated with multiple Intserv classes.

[44] Table I below summarizes the possible combinations of logical queues and virtual pools that may be implemented within the boundary and edge routers of a service provider network.

-14-

Table I

Logical Queue	Virtual pool	
	Separate	Shared
Separate	Case 1	Not Applicable
Shared	Case 3	Case 2

[45] As shown in Table I, three cases are possible: separate virtual pools with separate logical queues, shared virtual pools with shared logical queues, and separate virtual pools with shared logical queues. The case of a virtual pool shared by multiple Intserv classes is not applicable to an implementation having separate logical queues for each Intserv class, since no virtual pool information would be available on an individual class basis. Importantly, boundary and edge routers in the same network may be configured to concurrently implement different cases, as long as marking is correctly performed.

[46] With reference now to **Figures 5** and **6**, there are depicted more detailed block diagrams of edge and boundary routers of the network model of **Figure 3** in which traffic in each Intserv service class is assigned a separate virtual pool in the control plane and separate logical queue in the data plane in accordance with Case 1 of Table I. Referring first to **Figure 5**, a more detailed block diagram of ER-TX **150** is depicted. As noted above, ER-TX **150** has an Intserv control plane **150a**, which manages RSVP signaling and implements Intserv policy and admission control, and a data plane **150b**, which provides the link level delivery of Diffserv class-based QoS. Control plane **150a** includes an RSVP process **180**, an admission control block **182** having associated virtual pools **184**, a policy control block **188**, an IS-DS interworking function (IWF) configuration block **186**, and a Policy Configuration Interface (PCI) **190** through which ER-TX **150** communicates policy information with PDP **160a**. Data plane **150b** has an input port **200**, a forwarding function **208**, and an output port **210** having a number of queues **212** that each corresponds to a Diffserv class.

-15-

[47] As described above, RSVP process 180 in control plane 150a handles RSVP signaling (e.g., PATH and RESV messages) utilized to reserve (and release) resources for enhanced QoS flows. In response to receiving a RESV message requesting resources for an enhanced QoS flow, RSVP process 180 interrogates admission control block 182 and policy control block 188 to verify that the requestor has administrative permission to establish the QoS flow and that the downstream interface has sufficient available resources to support the requested QoS. In addition to determining administrative permission, policy control block 188 can execute additional policies, such as authentication based on certificates or signatures, management of bandwidth distribution among the authorized requestors, and preemption of allocated resources for a pending, higher-priority flow.

[48] In the illustrated embodiment, each supported Intserv class (e.g., Guaranteed Service (GS) and Controlled Load (CL)) has a separate virtual pool 184a, 184b. Admission control block 182 monitors the availability of resources on the downstream link for each Intserv class using virtual resource pools 184. Thus, admission control block 182 grants reservation requests when sufficient available bandwidth is available in the virtual pool associated with the requested Intserv class and otherwise denies the reservation request. Admission control block 182 reduces the available resources in a virtual pool by the amount requested by each successful reservation, and increases the reservable resources in a virtual pool by the amount of resources freed upon termination of a flow. Importantly, the number of virtual pools, the bandwidth allocated to each virtual pool 184, and the mapping between the virtual pools and Diffserv classes are not fixed, but are instead expressed as policies that are installed at ER-TX 150 (and other network elements) by a PDP 160. Utilizing Common Open Policy Service (COPS) or other protocol, such policies may be pushed onto network elements by PDP 160 or pulled from PDP 160 by a network element, for example, in response to receipt of an RSVP RESV message.

-16-

[49] PDP 160a configures the mapping between Intserv classes and Diffserv classes (and DSCPs) on IS-DS IWF configuration block 186 (e.g., GS to DSCP 100011, CL to DSCP 010011). IS-DS IWF configuration block 186 may also receive configurations from RSVP process 180. Based upon these configurations, IS-DS IWF configuration block 186 dynamically provisions a packet classifier 202, policer 204, and marker 206 on input port 200 for each Intserv flow. (In some implementations, packet classifier 202, policer 204, and marker 206 may be implemented as a single integrated module, such as a Field Programmable Gate Array (FPGA) or Application Specific Integrated Circuit (ASIC).)

[50] In accordance with this provisioning, packets within each Intserv flow, whose service class is indicated by an Intserv 5-tuple, are classified and marked by packet classifier 202 and marker 206 with the appropriate DSCP of the aggregate Diffserv class (e.g., with one of the 16 code points (Pool 2 xxxx11) reserved for experimental or local use). In this manner, Intserv flows having enhanced QoS are aggregated into preferential Diffserv classes. Because the embodiment shown in Figure 5 reflects Case 1 from Table I, a separate logical queue 212 is provided on port 210 for each supported Intserv class (GS and CL) in addition to the logical queues assigned to other Diffserv classes (e.g., the Expedited Forwarding (EF), Assured Forwarding (AF) and default Best Effort (BE) classes). Scheduler 214 then provides the appropriate QoS to the packets within each logical queue 212 by scheduling packet transmission from logical queues 212 in accordance with scheduler weights assigned to each logical queue 212 by PDP 160a.

[51] Because the illustrated embodiment of ER-TX 150 is managed by the network service provider, ER-TX 150 can be trusted by the network service provider to correctly mark packets with DSCPs so that no "theft" of QoS occurs. In alternative embodiments in which ER-TX is not managed by the network service provider, PDP server 160a may provide the Diffserv classification policies to BR-TX 152 instead of ER-TX 150. It should also be noted

-17-

that core routers of Diffserv network 154 need not implement separate Diffserv queues for Intserv flows, even if separate queues are implemented on edge and boundary routers.

[52] Referring now to **Figure 6**, there are illustrated more detailed block diagrams of BR-RX 156 and ER-RX 158 in accordance with a preferred implementation of Case 1 of Table I. As noted above, BR-RX 156 and ER-RX 158 have respective control planes 156a, 158a and data planes 156b, 158b. Control plane 158a of ER-RX 158 is an enhanced Intserv control plane including a PCI 190, an RSVP process 180 having associated admission and policy control blocks 182 and 188, and an edge point identification table 252 and upstream virtual pools 250 by which admission control block 182 performs upstream admission control. BR-RX 156a, by contrast, has no Intserv control plane, but instead includes only a PCI 190 through which the components of data plane 156b are configured by PDP 160b.

[53] Within control plane 158a of ER-RX 158, PDP 160b installs policies by which local policy control 188 determines which customers having administrative permission to request resource reservations for enhanced QoS flows. In addition, PDP 160b installs an edge point identification table 252 that specifies one or more ranges of destination IP addresses for which ER-RX 158 is the receiving edge router. Thus, upon receipt of a RESV message requesting an enhanced QoS flow for which the customer is granted administrative permission by policy control 188, admission control 182 interrogates edge point identification table 252 to determine if ER-RX 158 is the receiving edge router for the requested flow. If not, ER-RX 158 performs only conventional downstream admission control. However, if edge point identification table 252 indicates that ER-RX 158 is the receiving edge router for the requested flow, admission control block 182 performs upstream admission control by reference to the upstream virtual pool capacities allocated by PDP 160b to each Intserv class within virtual pools 250. As described generally above, each virtual pool 250a, 250b is utilized by admission control block 182 to ascertain the availability of sufficient bandwidth for a requested flow of a particular Intserv class on the upstream link

-18-

between ER-RX 158 and BR-TX 152. As indicated at reference numeral 252, PDP 160b obtains periodic or solicited feedback regarding virtual pool usage on ER-RX 158 and dynamically coordinates any operator-initiated adjustments to the capacities of the virtual pools with updates to the logical queue(s) and scheduler weight(s) implemented in the data plane to ensure that the Intserv bandwidth actually utilized is less than the operator-specified capacity.

[54] Referring now to the data plane, data plane 158b of ER-RX 158 may be implemented with conventional classification, forwarding and Intserv queuing, the details of which are omitted to avoid obscuring the present invention. Data plane 156b of BR-RX 156 includes an input port 220 having a classifier 222, an output port 240 having a plurality of Diffserv physical queues 242 and a scheduler 244, and a forwarding function 230 that switches packets from the input port to the appropriate physical queues 242 on output port 240 in accordance with the classification performed by classifier 222. As indicated, classifier 222 and physical queues 242 are configured by PDP 160b in a coordinated manner to reflect the configuration of upstream Intserv virtual pools on control plane 158a of ER-RX 158. In particular, in the illustrated embodiment, classifier 222 is configured to identify packets belonging to the separate Diffserv classes into which Intserv traffic are aggregated, such the packets in each Diffserv class representing an Intserv traffic type are forwarded to separate physical queues 242 for Intserv GS and CL classes on output port 240. PDP 160b also configures the scheduling weight scheduler 244 gives each of queues 242. In addition, PDP 160 coordinates the sum of the virtual pool capacities on ER-RX 158 with the resource pool capacity dictated by queue capacities and weights in data plane 156b of BR-RX 156 to ensure that the virtual pool capacity does not exceed the actual resource pool capacity. Thus, in essence, ER-RX performs upstream admission control as a proxy for BR -RX.

[55] Mapping different Intserv classes to separate virtual pools and Diffserv queues as shown in Figures 5 and 6 permits better traffic management than mapping all Intserv classes

-19-

to a single Diffserv queue. By preserving the distinction between Intserv classes over the Diffserv network in this manner, different traffic types (e.g., VoIP, VideoIP and file transfer) can be provided optimal handling, and enterprise resource planning is simplified. However, as noted above, some or all routers in a service provider network may alternatively be implemented in accordance with Cases 2 and 3. To implement Case 2 instead of Case 1, ER-TX 150 and ER-RX 158 are configured with a single shared virtual pool for multiple Intserv classes, and ER-TX 150 and BR-RX 156 are configured with a single shared logical queue for the multiple Intserv classes. Alternatively, to implement Case III, ER-TX 150 and ER-RX 158 are configured with separate virtual pools, and ER-TX 150 and BR-RX 156 are each configured with a single shared queue for multiple Intserv classes.

[56] It should be noted that no flow-specific network configuration of control plane 152a or data plane 152b of BR-TX 152 is required in order to provide enhanced QoS to particular flows. This is because the admission control provided by downstream ER-RX 158 ensures that the downstream link of BR-TX 152 has sufficient bandwidth to support each admitted enhanced QoS flow, and the mapping of Intserv flows to particular Diffserv classes ensures that data plane 152b achieves the requested QoS.

IV. PDP

[57] With reference now to Figure 7, there is depicted a high level block diagram of a server computer system that may be employed as a PDP 160 in accordance with a preferred embodiment of the present invention. PDP 160 includes one or more processors 262 coupled by an interconnect 264 to a storage subsystem 268, which may comprise random access memory (RAM), read only memory (ROM), magnetic disk, optical disk and/or other storage technology. Storage subsystem 268 provides storage for data (e.g., tables 280-290) and instructions (e.g. configuration manager 292) processed by processor(s) 262 to configure network elements and to install and determine network policies. Also coupled to interconnect 264 may be one or more input devices (e.g., a keyboard and/or graphical

pointing device) 270 and one or more output devices (e.g., a display) 272, as well as a communication interface 274 through which computer system 260 may communicate with network devices, such as routers 150, 152, 156 and 160.

[58] To configure and install policies on routers 150, 156, 160 in the manner described above, each PDP 160 preferably implements a number of Policy Rule Class (PRC) tables within storage subsystem 268. In one preferred embodiment, these PRC tables include at least an Admission Control Virtual Pool Table 280, Intserv Capacity Table 282, Intserv-to-Diffserv Interworking Function Table 284, Edge Point Identification Table 286, Pool Usage Feedback Table 288, and Boundary Resource Pool Table 290.

[59] Admission Control Virtual Pool Table 280 determines the capacities of the virtual pools on edge routers 150, 158 that are utilized to perform admission control for various Intserv classes. In Admission Control Virtual Pool Table 280, the sum of the capacities assigned to the virtual pools associated with all Intserv classes is set to be less than the data plane queue capacity of the associated boundary router to ensure that the requested QoS of each admitted flow can be achieved in the data plane. The table further specifies whether the admission control will accept reservations and the logical interface name of the boundary router associated an edge router. In an exemplary embodiment, Admission Control Virtual Pool Table 280 may be defined as follows:

AdmCtlVirtualPoolTable

Logical Interface Name

Description: This SNMP string identifies the logical interface associated with the AdmCtlVirtualPool entry.

Object Type: SNMP string

Direction

Description: This attribute indicates the relationship of the traffic stream to the interface as either (1) inbound or (2) outbound. This attribute is used in combination with the BoundaryLogicalInterfaceName to differentiate ER-RX virtual resource pools and ER-TX virtual resource pools. An ER-RX upstream virtual resource pool has an inbound Direction and non -

-21-

resource pools and ER-TX virtual resource pools. An ER-RX upstream virtual resource pool has an inbound Direction and non-empty BoundaryLogicalInterfaceName. An ER-TX downstream virtual resource pool has an outbound Direction and a non-empty BoundaryLogicalInterfaceName attribute. An ER-RX downstream virtual resource pool has an outbound Direction and an empty BoundaryLogicalInterfaceName attribute.

IntSrvClass

Description: This bit string indicates the Intserv class or classes that have resources allocated by admission control from this virtual pool.

Object Type: bits

Controlled Load Service (1)

Guaranteed Services (2)

Null Service (3)

Other (4)

VirtualPoolMaxAbsRate

Description: the maximum absolute rate in kilobits that this pool may allocate to Intserv sessions defined by the AdmCtlIntSrvClass. The sum of ER-RX upstream virtual resource pools is not to exceed the ResourcePoolMaxAbsRate for the associated BoundaryInterfaceName.

Object Type: Unsigned 32

BoundaryLogicalInterfaceName

Description: identifies the adjacent boundary router and resource pool that governs the capacity of the local virtual pool defined by this entry. An empty attribute signifies that the VirtualPoolMaxAbsRate is governed by a local ResourcePoolMaxAbsRate defined for the LogicalInterfaceName of this entry. A non-empty attribute indicates that a remote virtual pool capacity defined for this BoundaryLogicalInterfaceName governs the value of the VirtualPoolMaxAbsRate of this entry.

Object Type: SNMP string

AcceptReservations

Description: This value indicates whether Admission Control will attempt to process RSVP RESV requests. A value of 0 indicates that reservations are not to be processed. A value of 1 indicates reservations are to be processed.

Object Type: Unsigned 32

-22-

[60] Intserv Capacity Table 282 defines the data plane data rate capacity allocated to Intserv classes in terms of both Diffserv queue weights and shaper parameters. These rate capacities are also associated by the table with one or more edge router virtual pools. This Policy Rule Class, according to one preferred embodiment, is contained in the Differentiated Services Policy Information Base (PIB).

[61] Intserv-to-Diffserv IWF Table 284 defines the attributes used for interworking between the RSVP process in the control plane and Diffserv in the data plane. These attributes are used by classifier 202, policer 204, and marker 206 on input port 200 of ER-TX 150 to classify, police and mark Intserv traffic flows so that Diffserv achieves the appropriate QoS for each flow. In addition, the table specifies the specific scheduler instance to be used for flows having particular Intserv classes. An exemplary embodiment of Intserv-to-Diffserv IWF Table 284 is as follows:

Intserv-to-Diffserv Interworking Function Table

IwfPrid

Description: This is the unique identifier of the PktIwfTable entry.

Object Type: Instance ID (unsigned 32)

IwfIntSrvClass

Description: The value of the Intserv Class associated with the attributes of this specific interworking function entry. (It must have a corresponding bit set in AdmCtlIntSrvClass)

Object Type: unsigned 32

IwfDSCP

Description: The value of the DSCP to assign the data stream for the session with the Intserv class type matching the value of PktIwfIntSrvClass.

Object Type: integer value 0 - 63

IwfOutOfProfile

Description: This value indicates the policing behavior when the data stream is out of profile. The profile can be defined by the associated MeterTableEntry. A value of 1 indicates out-of-profile packets are to be dropped. A value of 2 indicates out-of-profile packets are to be remarked with the DSCP defined in IwfRemarkValue.

Object Type: Unsigned 32

IwfRemarkValue

Description: The value of the DSCP to remark an out-of-profile packet. This value is only used if the IwfOutOfProfile is set to 2.

Object Type: Unsigned 32 value 0-63

IwfSchedulerPrid

Description: The value of the instance ID of the specific scheduler to be used by data streams of the sessions with an Intserv class matching the value of attribute IwfIntSrvClass.

Object Type: Unsigned 32

[62] Edge Point Identification Table 286 defines a range or ranges of addresses for which an edge router is a receiving edge router. This information may be configured on PDP 160 initially or may be learned locally. Admission control block 182 on ER-RX 158 performs upstream admission control for reservation requests that specify a destination address within the RSVP SESSION Object that falls within one of these address ranges. The values for a particular edge router may be pushed down by PDP 160 to the local Edge Point Identification

Table 252 utilizing COPS or other policy protocol. According to one embodiment, Edge Point Identification Table 286 may be defined as follows:

End Point Identification Table

ReceiverDomainPrid

Description: unique identifier of an entry of this policy rule class
Object Type: Instance ID, a 32 bit unsigned integer.

ReceiverAddrType

Description: The enumeration value that specifies the address type as defined in RFC 2851 [M. Daniele et al., "Textual Conventions for Internet Network Addresses" June 2000]
Object Type: INET Address Type as defined by RFC 2851

ReceiverAddr

Description: The IP address for the Session Object Destination Address to match
Object Type: INET Address as defined by RFC 2851

ReceiverAddrMask

Description: the length of the mask for matching the INET Address
Object Type: unsigned 32

[63] Pool Usage Feedback Table 288 contains entries that specify the current resources consumed by Intserv flows. This PRC table, which is used by PDP 160 to determine when to complete provisioning an operator-initiated capacity update, may in an exemplary embodiment be defined as follows:

Pool Usage Feedback Table

Usage Feedback Prid

Description: unique identifier of the Virtual Pool Usage Feedback entry.
Object Type: Instance Id. (unsigned 32)

PoolPrid

Description: value of the instance ID of the specific AdmCtlVirtualPool entry that usage is describing.
Object Type : Unsigned 32

-25-

ResourceAbsRateInUse

Description: current total value of the Intserv resources in use.

[64] Boundary Resource Pool Table 290 defines the total rate capacity that may be assigned by PDP 160 to the various admission control virtual pools associated with a given egress boundary router (BR-RX). This PRC table may be defined in an exemplary embodiment as follows:

Boundary Resource Pool Table**BoundaryResourcePool TableBoundaryResourcePoolPrid**

Description: unique identifier of the Virtual Pool Usage Feedback entry

Object Type: Instance Id. (unsigned 32)

BoundaryLogical Interface Name

Description: identifies the adjacent boundary router and resource pool that governs that capacity of the local virtual pools associated with this entry in the AdmissionCtlVirtualPool Table

Object Type: SNMP string

ResourcePoolMaxAbsRate

Description: maximum absolute rate in kilobits that may be allocated to IntServ sessions defined by the AdmCtlIntSrvClass. The sum of ER -RX upstream virtual pools is not to exceed the ResourcePoolMaxAbsRate for the associated BoundaryInterfaceName.

Object Type: Unsigned 32

V. Network Configuration

[65] With reference now to **Figures 8A-8C**, a number of network diagrams are depicted, which together illustrate preferred techniques by which PDP 160b configures and installs policies on BR-RX 156 and ER-RX 158. The illustrated functions may be implemented, for example, through the execution by PDP 160 of configuration manager software 292. In each figure, it is assumed that communication between PDP 160b and routers 156, 158 is conducted utilizing COPS, although it should be understood that other protocols may be

employed.

[66] **Figure 8A** specifically illustrates **PDP 160b** synchronizing virtual pool capacities on **ER-RX 158** with Diffserv logical queue bandwidths on **BR-RX 152** during service initialization. As indicated at reference numeral **300** of **Figure 8A**, a Network Management System (NMS) may initiate the configuration of Intserv capacity for a customer, for example, during service initialization. In response, **PDP 160b** pushes the configuration of Intserv virtual pool capacities onto each network-managed edge router (of which only **ER-RX 158** is shown) that is downstream of a boundary router of Diffserv network **154**. For example, in the depicted embodiment, **PDP 160b** pushes the virtual pool capacity for each Intserv class supported by LP1 at interface 1.m.n.b/30 onto **ER-RX 158** with a message allocating 10 megabits to the Intserv GS class and 25 megabits to the Intserv CL class. If the configuration is successfully installed on **ER-RX 158**, **ER-RX 158** replies with an acknowledgement (ACK) message, as shown at reference numeral **304**. **PDP 160b**, as indicated at reference numeral **306**, then pushes the corresponding configuration of Diffserv queue(s) and scheduler weight(s) onto **BR-RX 156**. **BR-RX 156** also returns an ACK **308** to **PDP 160b** if the configuration is successfully installed.

[67] If **ER-RX 158** fails to install the virtual pool capacities pushed down by **PDP 160b**, **ER-RX 158** returns a negative acknowledgement (NACK) to **PDP 160b**. **PDP 160b** accordingly sends a warning message to a network operator, such as "Fail to configure Integrated Services virtual pool on ER XX!" Similarly, if the queue(s) and scheduler weight(s) cannot be installed on **BR-RX 156**, **BR-RX 156** returns an NACK to **PDP 160b**. In response, **PDP 160b** transmits a message to **ER-RX 158** to release the configuration of the virtual pools and may also send a warning message to a network operator stating: "Fail to configure Queue and Scheduler on BR XX!"

-27-

[68] It should be noted that PDP 160b may not directly communicate with network elements, such as BR-RX 156 and ER-RX 158, but may instead communicate through other network elements. For example, messages between PDP 160b and BR-RX 156 may be communicated through ER-RX 158.

[69] Attention is now turned to a scenario in which a service update (i.e., an increase or decrease in subscribed Intserv capacity) is performed for an existing network service customer. Increasing or decreasing the BR-RX capacity when the currently reserved bandwidth is below the new subscribed capacity is a straightforward process because the new capacity can accommodate all ongoing customer traffic, meaning no service impact will be observed. However, decreasing the BR-RX capacity when the currently reserved bandwidth is greater than the newly requested capacity requires coordination among PDP 160b, BR-RX 156, and ER-RX 158, as described below with respect to **Figure 8B**.

[70] In **Figure 8B**, the NMS may initiate the reconfiguration of Intserv capacity for an existing network service customer, as depicted at reference numeral 320. As shown at reference numeral 322, PDP 160b installs the new virtual pool capacity value(s) on ER-RX 158. Admission control block 182 of ER-RX 158 compares each new virtual pool capacity value with the amount of resources currently reserved within each virtual pool. If the new virtual pool capacity value(s) are greater than the amount of resources currently reserved from each virtual pool, admission control block 182 of ER-RX 158 overwrites the virtual pool capacity value(s) with the new value(s) and immediately sends an ACK 324 to PDP 160b. However, if the new virtual pool capacity value(s) are less than the amount of currently reserved resources, admission control block 182 of ER-RX 158 saves the new capacity value(s) without overwriting the old ones. Admission control block 182 of ER-RX 158 accepts no new reservations from a virtual pool to which an update is to be performed until the amount of reserved resources falls below the new virtual pool capacity. Once the reserved resources fall below the new virtual pool capacity, admission control block 182 of

-28-

ER-RX 158 overwrites the old virtual pool capacity value(s) with the new value(s), and acknowledges acceptance of the new virtual pool capacity value(s) by sending an ACK 324 to PDP 160b.

[71] PDP 160b defers installation of new scheduler weight(s) on BR-RX 156 until PDP 160b receives ACK 324 from ER-RX 158. In response to ACK 324, PDP 160b pushes queue configuration(s) and scheduler weight(s) onto BR-RX 156, as illustrated at reference numeral 326. After successful installation of the new queue configuration(s) and scheduler weight(s), BR-RX 156 returns an ACK 328 to PDP 160b.

[72] In an alternative embodiment, PDP 160b determines when to perform a virtual pool capacity update instead of ER-RX 158. In this embodiment, PDP 160b solicits reports of or programs periodic unsolicited reporting by ER-RX 158 of the currently reserved Intserv bandwidth. If the currently reserved bandwidth is greater than the new capacity specified by the NMS, PDP 160b pushes a policy to ER-RX 158 to stop accepting new reservations until the reserved bandwidth is below the new capacity. To further reduce the amount of messaging, PDP 160b may push a policy on ER-RX 158 that instructs ER-RX 158 to send a single unsolicited report to PDP 160b only after the reserved bandwidth is less than the new capacity. In response to a message from ER-RX 158 indicating that the currently reserved Intserv bandwidth is less than the new virtual pool capacity, PDP 160b pushes the new Intserv virtual pool policy onto ER-RX 158 and pushes the corresponding new scheduler queues and weights to BR-RX 156 in the manner described above.

[73] If PDP 160b fails to successfully update either ER-RX 158 or BR-RX 156, PDP 160b may roll back to the old virtual pool capacities and queue and scheduler weight configuration. Additionally, PDP 160b may send warning messages to the network operator to describe the reason of the failure (e.g., "Failure to configure the updated Integrated

Services virtual pool capacity on ER XX!” or “Failure to configure the updated scheduler weight on BR,XX!”).

[74] To prevent a PDP (e.g., PDP server 160b) from becoming a single point of failure, a backup PDP may be utilized for one or more primary PDPs. In the event that a primary PDP fails, the Intserv service control may be switched to the backup PDP, and each ER- RX controlled by the primary PDP may report its current reservation state to the backup PDP. However, each ER-RX should stop accepting new reservations until the switch to the backup PDP is completed. After the primary PDP is restored, the backup PDP first synchronizes state with the primary PDP and then informs each ER- RX to switch back to the primary PDP. After switching back to the primary PDP, each ER-RX synchronizes its reservation state with the primary PDP.

[75] In the event of a failed ER or BR, IP routing and RSVP refresh messages are used to discover a new route and reroute flows around the failed ER or BR. Upon successful rerouting, PDP 160b may push a policy to the corresponding BR-RX 156 to release the Diffserv queues allocated to Intserv traffic for the failed ER-RX or push policies to all downstream ER-RXs of a failed BR-RX to release the configured virtual pool(s) for the failed BR-RX.

[76] Referring now to **Figure 8C**, there is illustrated an exemplary scenario in which an NMS or network service provider operator directly alters the configuration of queue(s) and scheduler weight(s) on BR-RX 156. In response to the update, BR-RX 156 notifies PDP 160b of the changes. If not contained in the notification, PDP 160b pulls the configuration update from BR-RX 156, as indicated at reference numeral 342, and then, as depicted at reference numeral 344, pushes the new configuration of virtual pool capacities onto all affected ER-RX(s) (of which only ER-RX 158 is shown).

VI. Conclusion

[77] As has been described, the present invention provides a scalable IP network model that provides end-to-end QoS for selected flows by implementing edge-based Intserv over a Diffserv domain. The network model supports a number of functions, including per-flow admission control utilizing Intserv RSVP processing only at the CPE edge routers, receiving edge router identification, upstream admission control at the receiving edge router, pool-based resource management, and synchronization of bandwidth usage information between the receiving boundary router and receiving edge router by policy management. Despite introducing additional functionality, the network model of the present invention is consistent with existing Intserv, COPS and Diffserv models, and the Diffserv policy provisioning model using policy and management information bases. The network model of the present invention advantageously enhances scalability while maintaining a standardized architecture and can therefore be readily adopted for implementation.

[78] While various embodiments of the present invention have been described above, it should be understood that they have been presented by way of example only, and not limitation. Thus, the breadth and scope of the present invention should not be limited by any of the above-described exemplary embodiments, but should be defined only in accordance with the following claims and their equivalents. For example, although the present invention has been primarily discussed with respect to implementations employing Resource Reservation Protocol (RSVP) and Internet Protocol (IP), it should be appreciated the present invention has applicability to other communication protocols, including Session Initiation Protocol (SIP) and ITU H.323, which may be used to perform admission control by the selective admission or denial of an enhanced QoS flow based upon policy and available resources. Moreover, although the present invention has been described with respect to various hardware elements that perform various functions in order to achieve end-to-end QoS for selected network flows, it should be understood that such functions can be realized through the execution of program code embodied in a computer-readable medium. The term

-31-

“computer-readable medium” as used herein refers to any medium that participates in providing instructions to a data processing system for execution. Such a medium may take many forms, including but not limited to non-volatile media, volatile media, and transmission media.

CLAIMS

What is claimed is:

1. A router, comprising:
 - a data plane having an input port connectable to an upstream link and an output port connectable to a downstream link; and
 - a control plane including:
 - a virtual pool having a capacity corresponding to a resource capacity of an upstream router coupled to the upstream link; and
 - an admission control function that, responsive to a request to reserve resources for a flow through said data plane from said input port to said output port, performs admission control for the upstream link by reference to resource availability within said virtual pool.
2. The router of Claim 1, wherein:
 - said virtual pool is a first virtual pool;
 - said control plane further includes a second virtual pool;
 - each of said first and second virtual pools is associated with a respective one of first and second service classes; and
 - said admission control function performs admission control for said flow on said upstream link by reference to resource availability in one of said first and second virtual pools associated with a service class indicated by said request.

3. The router of Claim 1, wherein:
 - said first and second service classes comprise first and second Integrated Services service classes; and
 - said request is a Resource Reservation Protocol (RSVP) request for resource reservation for an Integrated Services flow.

4. The router of Claim 3, and further comprising a Resource Reservation Protocol (RSVP) function in communication with said admission control function, wherein said RSVP function receives said request and provides said request to said admission control function.

5. The router of Claim 1, wherein said admission control function includes means for determining whether said router is a receiving edge router for the flow, and wherein said admission control block performs admission control for the upstream link only in response to a determination that said router is the receiving edge router for the flow.

6. The router of Claim 1, and further comprising a policy control that determines whether a source of the flow is authorized to request resource reservation.

7. A network system, comprising:
 - a first router having an output port;
 - an upstream link coupled to the output port of the first router;
 - a second router, including:
 - a data plane having an input port coupled to the upstream link and an output port connectable to a downstream link; and
 - a control plane including:
 - a virtual pool having a capacity corresponding to a resource capacity of the first router; and
 - an admission control function that, responsive to a request to reserve resources for a flow from said input port to said output port through said data

plane, performs admission control for the upstream link by reference to resource availability within said virtual pool.

8. The network system of Claim 7, wherein:

said virtual pool is a first virtual pool;

said control plane further includes a second virtual pool;

each of said first and second virtual pools is associated with a respective one of first and second service classes; and

said admission control function performs admission control for said flow on said upstream link by reference to resource availability in one of said first and second virtual pools associated with a service class indicated by said request.

9. The network system of Claim 7, wherein:

said first and second service classes comprise first and second Integrated Services service classes; and

said request is a Resource Reservation Protocol (RSVP) request for resource reservation for an Integrated Services flow.

10. The network system of Claim 9, said second router further comprising a Resource Reservation Protocol (RSVP) function in communication with said admission control function, wherein said RSVP function receives said request and provides said request to said admission control function.

11. The network system of Claim 9, wherein said first router comprises a data plane including a forwarding function and a plurality of queues that each provide a different quality of service, wherein said forwarding function switches packets of Integrated Services flows into multiple different ones of said plurality of queues for transmission to said second router.

12. The network system of Claim 11, and further comprising a service provider network having a plurality of first routers including said first router, wherein each of said plurality of

first routers includes one or more queues, and wherein different first routers in said service provider network concurrently implement different mappings between Integrated Services classes and said one or more queues.

13. The network system of Claim 11, and further comprising a service provider network having a plurality of first routers including said first router, wherein each of said plurality of first routers is a Differentiated Services router supporting a plurality of Differentiated Services classes, and wherein different first routers in said service provider network concurrently implement different mappings between Integrated Services classes and said plurality of Differentiated Services classes in different ones of said plurality of Differentiated Services routers.

14. The network system of Claim 7, wherein said admission control function includes means for determining whether said second router is a receiving edge router for the flow, and wherein said admission control block performs admission control for the upstream link only in response to a determination that said second router is the receiving edge router for the flow.

15. The network system of Claim 14, wherein said edge router comprises a receiving edge router, and said network system further includes a transmitting edge router comprising:

- a data plane; and

- a control plane including:

- a virtual pool having a capacity corresponding to a resource capacity of a downstream link of said transmitting edge router; and

- an admission control function that, responsive to a request to reserve resources for a flow through said data plane of said transmitting edge router to said receiving edge router, performs admission control for the downstream link of the transmitting edge router by reference to resource availability within said virtual pool of the transmitting edge router.

16. The network system of Claim 7, said control plane further comprising a policy control that determines whether a source of the flow is authorized to request resource reservation.
17. The network system of Claim 7, and further comprising:
the downstream link connected to said output port; and
a customer network coupled to the downstream link.
18. A method of operating a router having an input port connected to an upstream link and an output port connected to a downstream link, said method comprising:
the router maintaining a virtual pool having a capacity corresponding to a resource capacity of an upstream router coupled to the upstream link;
said router receiving a request to reserve resources for a flow through said router onto said downstream link; and
in response to said request, said router performing admission control for the upstream link by reference to resource availability within said virtual pool.
19. The method of Claim 18, wherein:
said virtual pool is a first virtual pool;
maintaining a virtual pool comprises said router maintaining first and second virtual pools that are each associated with a respective one of first and second service classes; and
performing admission control comprises said router performing admission control for said flow on said upstream link by reference to resource availability in one of said first and second virtual pools associated with a service class indicated by said request.
20. The method of Claim 19, wherein:
said first and second service classes comprise first and second Integrated Services service classes; and
said receiving comprises receiving a Resource Reservation Protocol (RSVP) request for an Integrated Services flow.

21. The method of Claim 18, wherein said upstream router comprises a data plane including a plurality of queues, and wherein said method further comprises providing a plurality of different qualities of service to a plurality of Integrated Services flows utilizing said plurality of queues.

22. The method of Claim 21, wherein said first router belongs to a service provider network including a plurality of first routers each having one or more queues, said method further comprising concurrently implementing different mappings between Integrated Services classes and said one or more queues at different ones of said plurality of first routers.

23. The method of Claim 21, wherein said upstream router comprises one of a plurality of Differentiated Services routers that each support a plurality of Differentiated Services classes, said method further comprising concurrently implementing different mappings between Integrated Services classes and said plurality of Differentiated Services classes in different ones of said plurality of Differentiated Services routers.

24. The method of Claim 18, and further comprising determining whether said router is a receiving edge router for the flow, wherein said router performs admission control for the upstream link only in response to a determination that said router is the receiving edge router for the flow.

25. The method of Claim 18, and further comprising implementing policy control by determining whether a source of the flow is authorized to request resource reservation.

26. The method of Claim 18, wherein said router comprises a receiving edge router, and said method further comprises transmitting said request from said receiving edge router to a transmitting edge router.

27. The method of Claim 26, wherein said transmitting comprises transmitting said request to said transmitting edge router without performing admission control at any intervening router.

28. The method of Claim 26, and further comprising:

said transmitting edge router maintaining a virtual pool having a capacity corresponding to a resource capacity of a downstream link of said transmitting edge router; and

in response to receiving a request to reserve resources for the flow, said transmitting edge router performing admission control for a downstream link of the transmitting edge router by reference to resource availability within the virtual pool maintained by said transmitting edge router.

29. The method of Claim 18, and further comprising:

in response to admission of the flow, the router routing the flow to a customer network coupled to the downstream link.

30. A program product for operating a router having an input port connected to an upstream link and an output port connected to a downstream link, said program product comprising:

a computer usable medium; and

a control program including:

instructions for causing the router to maintain a virtual pool having a capacity corresponding to a resource capacity of an upstream router coupled to the upstream link;

instructions for causing the router to receive a request to reserve resources for a flow through said router onto said downstream link; and

instructions for causing the router, in response to said request, to perform admission control for the upstream link by reference to resource availability within said one or more resource pools.

31. The program product of Claim 30, wherein:
said virtual pool is a first virtual pool;
said instructions for causing said router to maintain a virtual pool comprise instructions for causing said router to maintain first and second virtual pools that are each associated with a respective one of first and second service classes; and
said instructions for causing said router to perform admission control comprise instructions for causing said router to perform admission control for said flow on said upstream link by reference to resource availability in one of said first and second virtual pools associated with a service class indicated by said request.
32. The program product of Claim 31, wherein:
said first and second service classes comprise first and second Integrated Services service classes; and
said instructions for causing said router to receive the request comprise instructions for causing said router to receive a Resource Reservation Protocol (RSVP) request for an Integrated Services flow.
33. The program product of Claim 30, and further comprising instructions for causing said router to determine whether said router is a receiving edge router for the flow, wherein said router performs admission control for the upstream link only in response to a determination that said router is the receiving edge router for the flow.
34. The program product of Claim 30, and further comprising instructions for causing said router to implement policy control by determining whether a source of the flow is authorized to request resource reservation.
35. The program product of Claim 30, wherein said router comprises a receiving edge router, said program product further comprising instructions for causing said receiving edge router to transmit said request to a transmitting edge router.

36. The program product of Claim 37, and further comprising:

instructions for causing said transmitting edge router to maintain a virtual pool having a capacity corresponding to a resource capacity of a downstream link of said transmitting edge router; and

instructions for causing said transmitting edge router, responsive to receipt of a request to reserve resources for the flow, to perform admission control for a downstream link of the transmitting edge router by reference to resource availability within the virtual pool maintained by said transmitting edge router.

37. The program product of Claim 30, and further comprising instructions for causing said router to route the flow to a customer network coupled to the downstream link in response to admission of the flow.

38. A data storage device, comprising:

a data storage medium; and

a virtual pool data structure encoded within said computer usable medium, wherein said virtual pool data structure specifies a virtual pool capacity for an egress edge router of a data network that includes an upstream boundary router having a resource capacity corresponding to the virtual pool capacity, said virtual pool capacity specifying a maximum reservable bandwidth that may be reserved at said egress edge router by traffic from said upstream boundary router in one or more service classes, and wherein said virtual pool data structure associates said virtual pool capacity with the upstream boundary router of the data network.

39. The data storage device of Claim 38, said virtual pool data structure further comprising a service class field specifying which of said one or more services classes have resources allocated to them from the virtual pool capacity.

40. The data storage device of Claim 38, said virtual pool data structure further comprising a reservation field indicating whether reservation requests requesting resources from the specified virtual pool capacity will be processed by an admission control function of the egress edge router.

41. The data storage device of Claim 38, and further comprising:

a resource capacity data structure encoded within said computer usable medium, wherein said resource capacity data structure specifies a resource capacity allocated to each of said one or more service classes within a data plane of a boundary router of a data network, and wherein said resource capacity data structure associates said resource capacity with one or more virtual pool capacities of downstream egress edge routers of the data network.

42. The data storage device of Claim 38, wherein said virtual pool data structure includes a plurality of entries that each specifies a virtual pool capacity for an associated edge router, and wherein said data storage device further comprises a boundary resource data structure, encoded within said computer usable medium, that specifies a maximum aggregate of said virtual pool capacities.

43. The data storage device of Claim 38, and further comprising:

a pool usage data structure encoded within said computer usable medium, wherein said pool usage data structure indicates a currently reserved portion of the virtual pool capacity.

44. A data storage device, comprising:

a data storage medium; and

an interworking function data structure encoded within said computer usable medium, wherein said interworking function data structure specifies a plurality of Differentiated Services traffic control parameters for an ingress edge router routing incoming flows of one

or more Integrated Services service classes, said traffic control parameters including at least a marking parameter and a scheduling parameter.

45. The data storage device of Claim 44, said traffic control parameters further including policing parameters.

46. A data storage device, comprising:
a data storage medium; and
an edge router identification data structure encoded within said computer usable medium, wherein said edge router identification data structure associates a router of a data network with one or more network addresses for which the router is a receiving edge router.

47. A data storage device, comprising:
a data storage medium; and
a pool usage data structure encoded within said computer usable medium, wherein said pool usage data structure indicates a currently reserved portion of virtual pool capacity for an egress edge router of a data network that includes an upstream boundary router having a resource capacity corresponding to the virtual pool capacity.

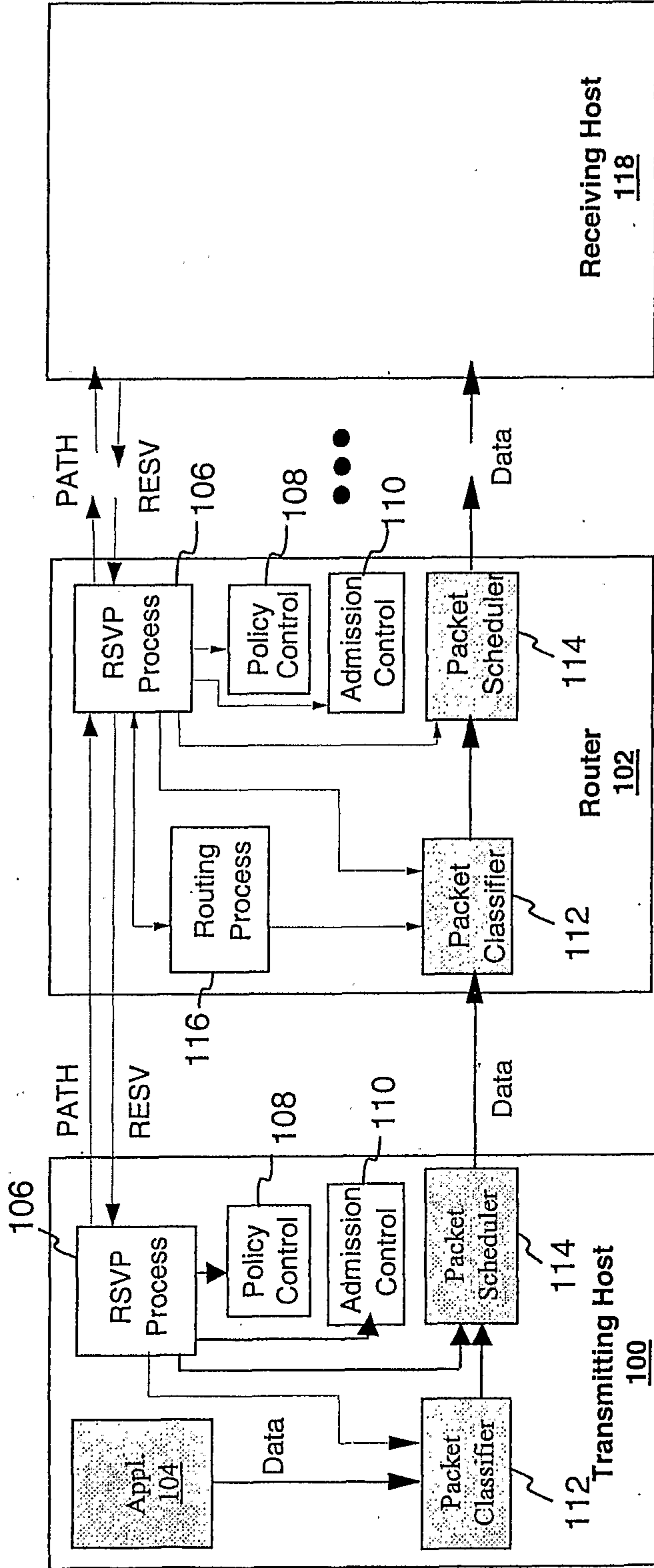

FIG. 1 PRIOR ART

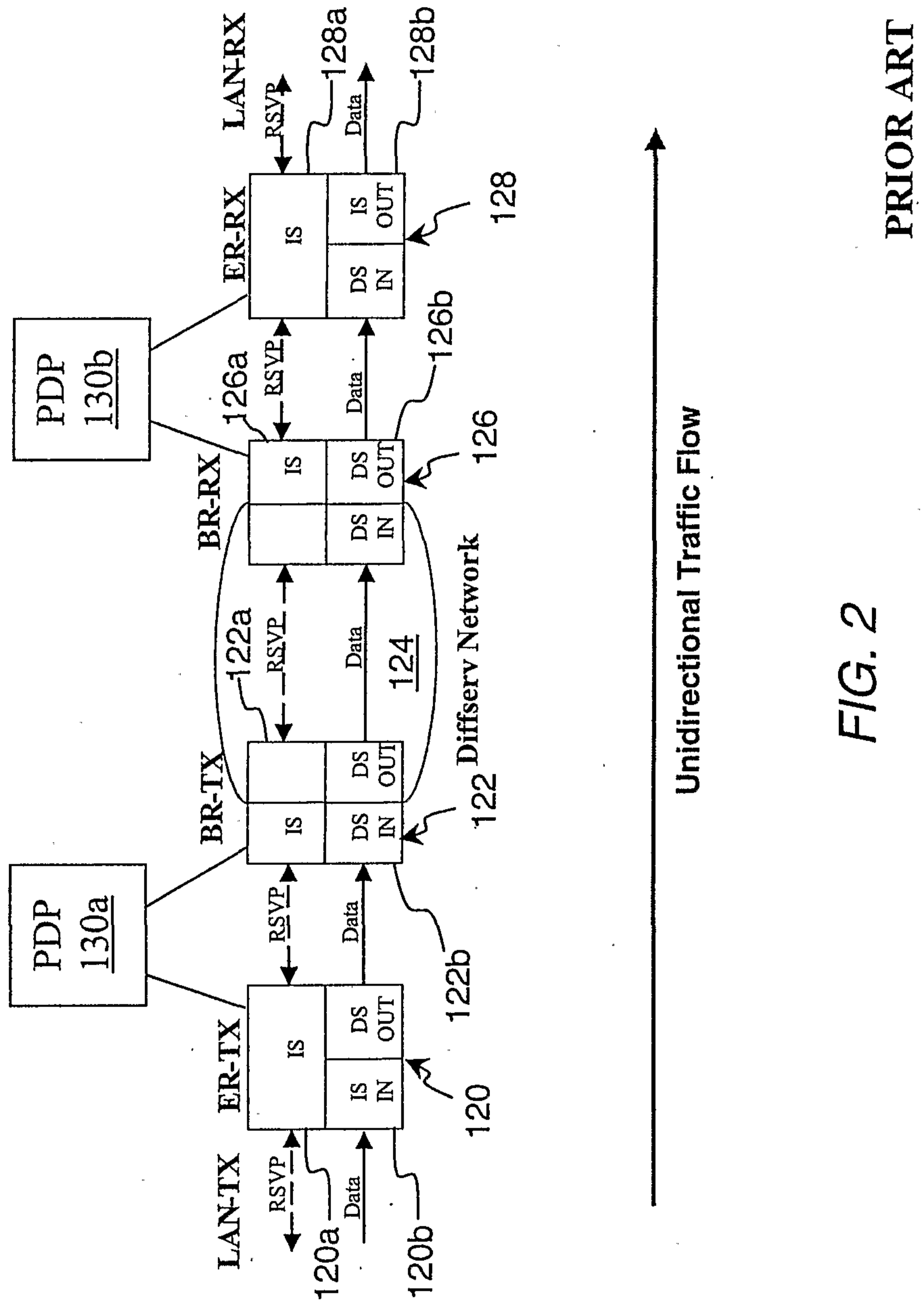

FIG. 2

PRIOR ART

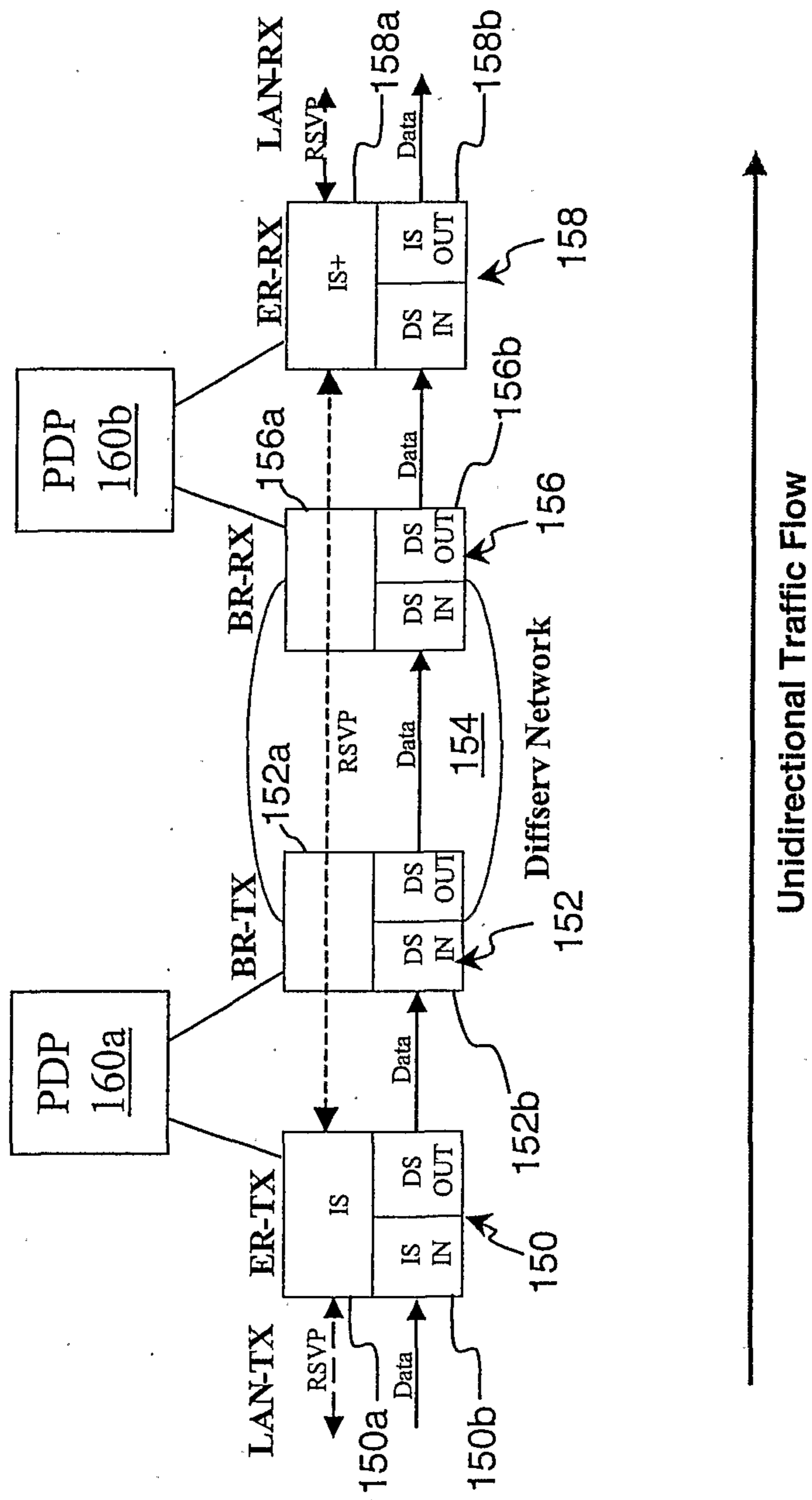

FIG. 3

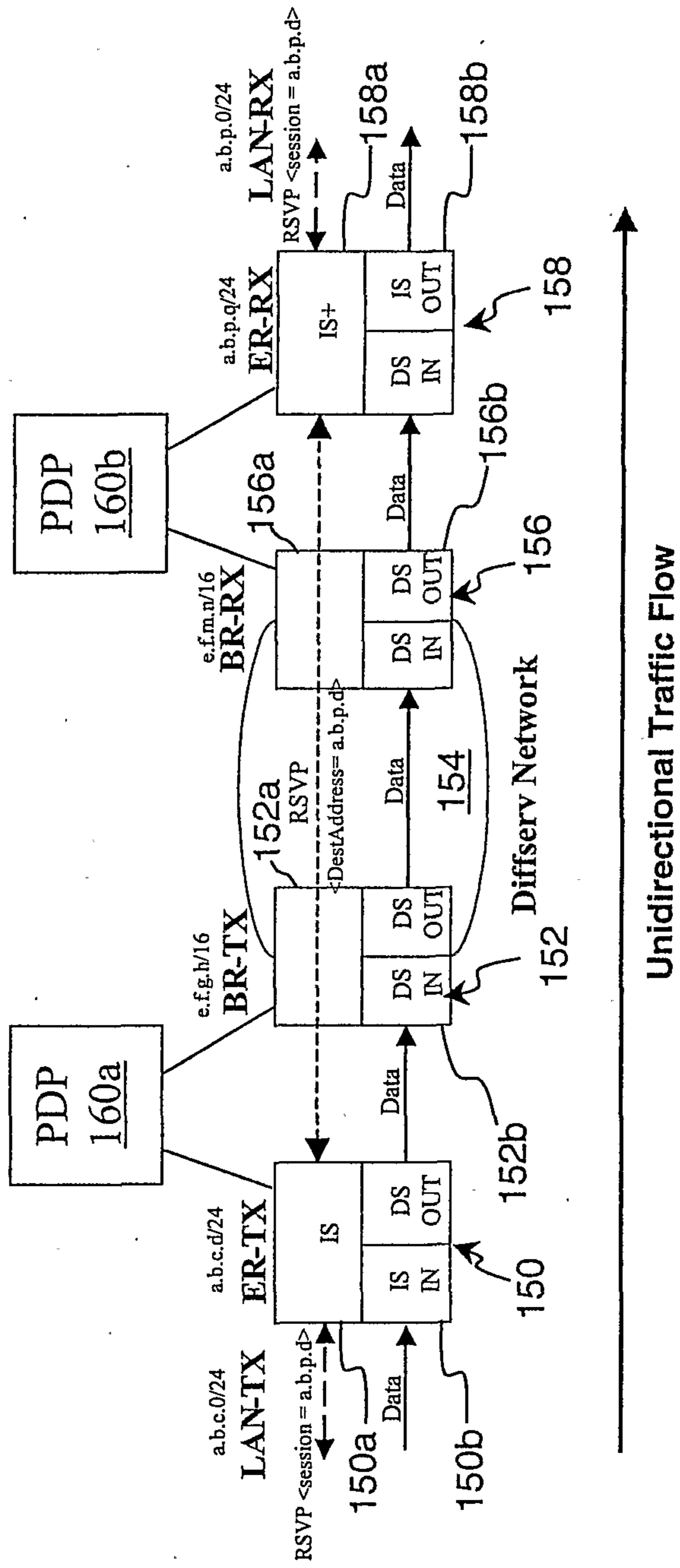
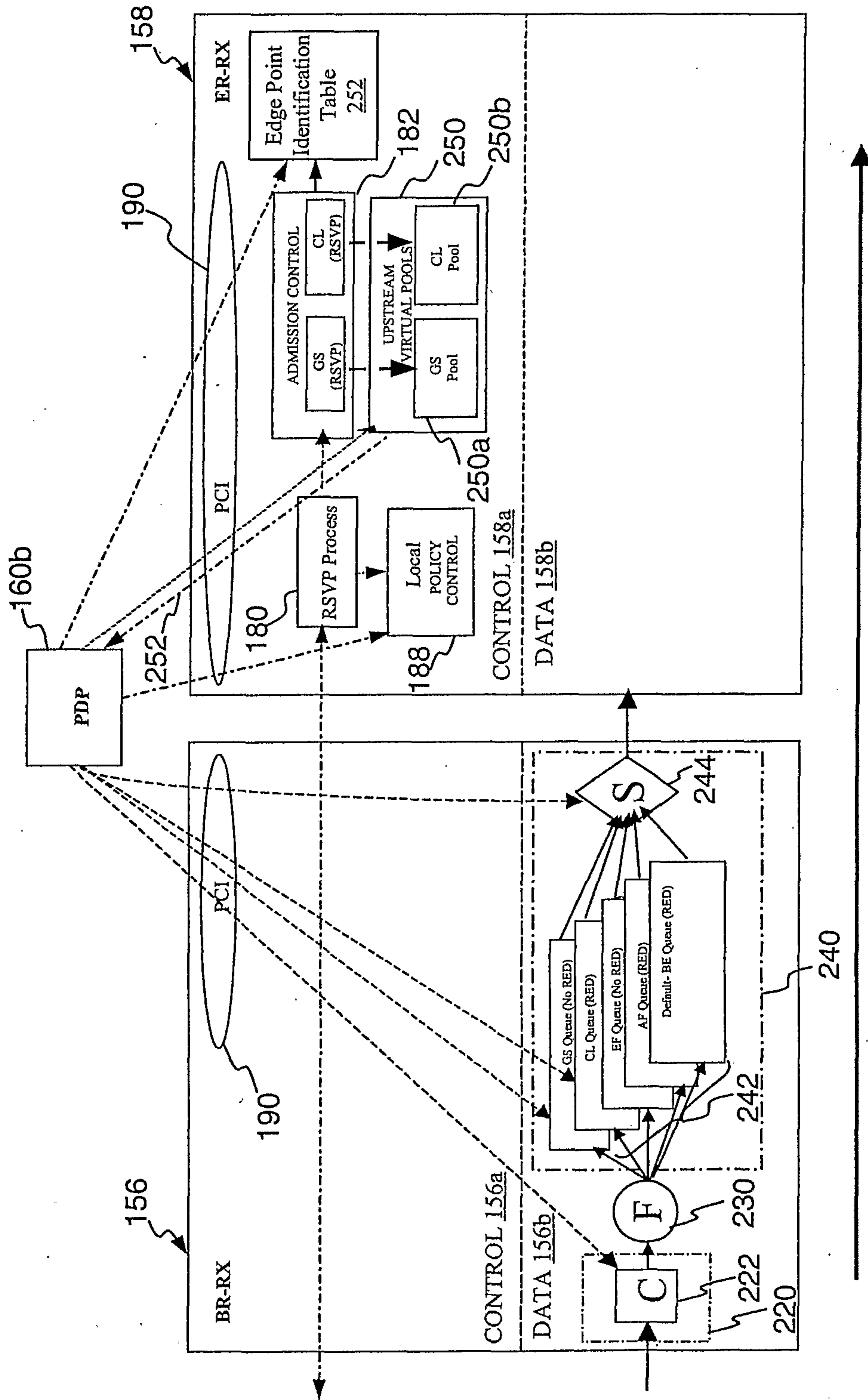

FIG. 4



Unidirectional Traffic Flow

FIG. 6

160 ↗

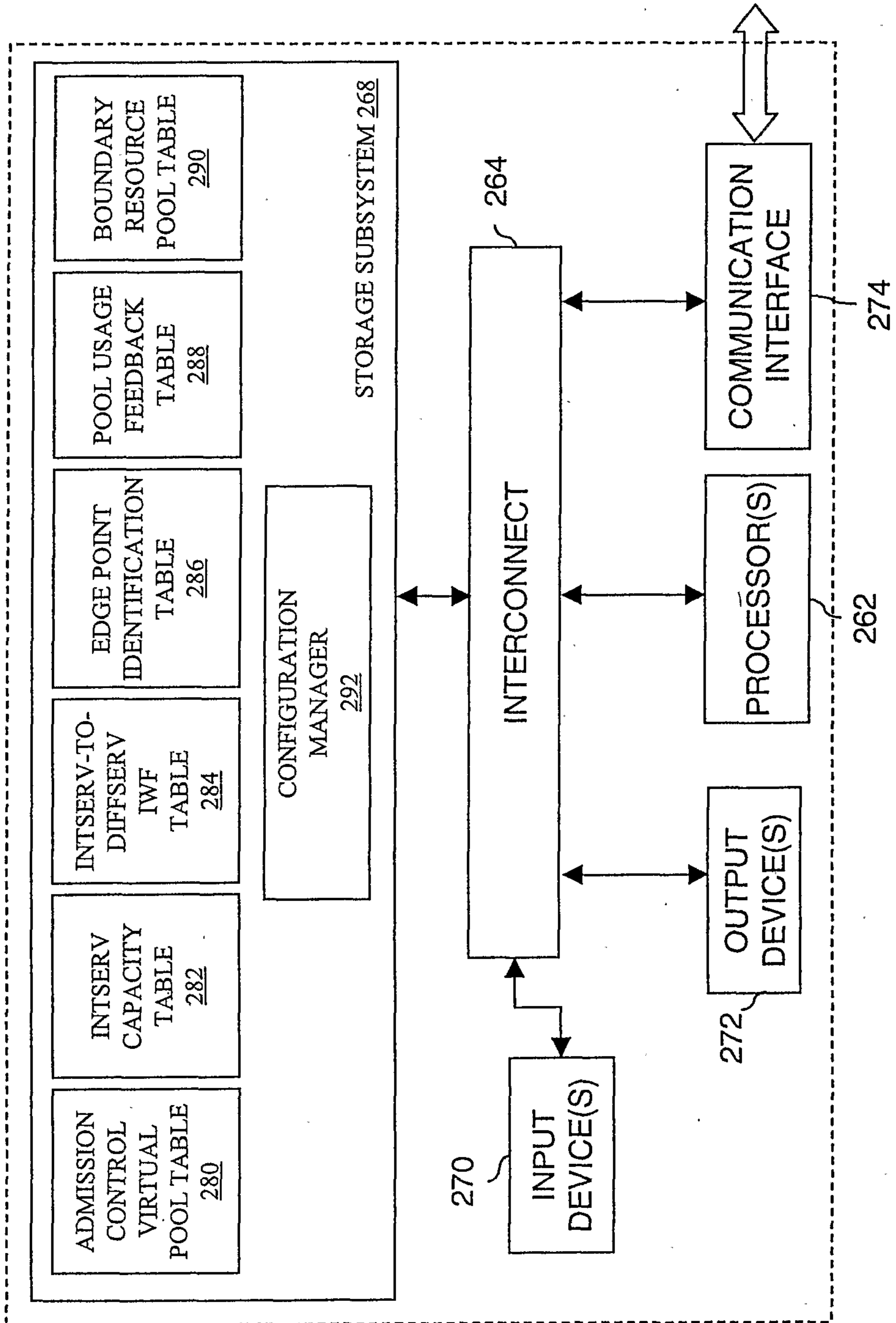

FIG. 7

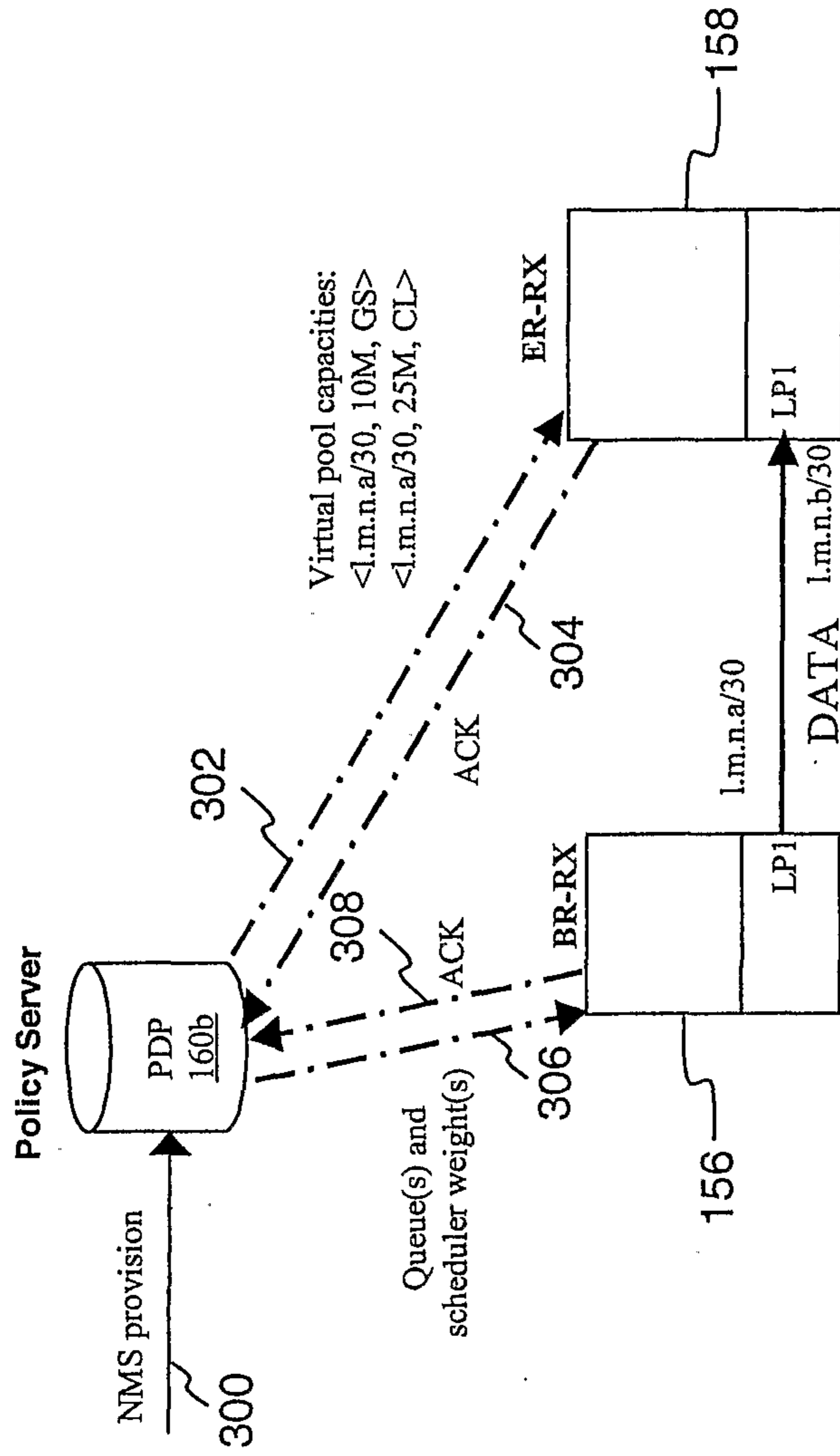

FIG. 8A

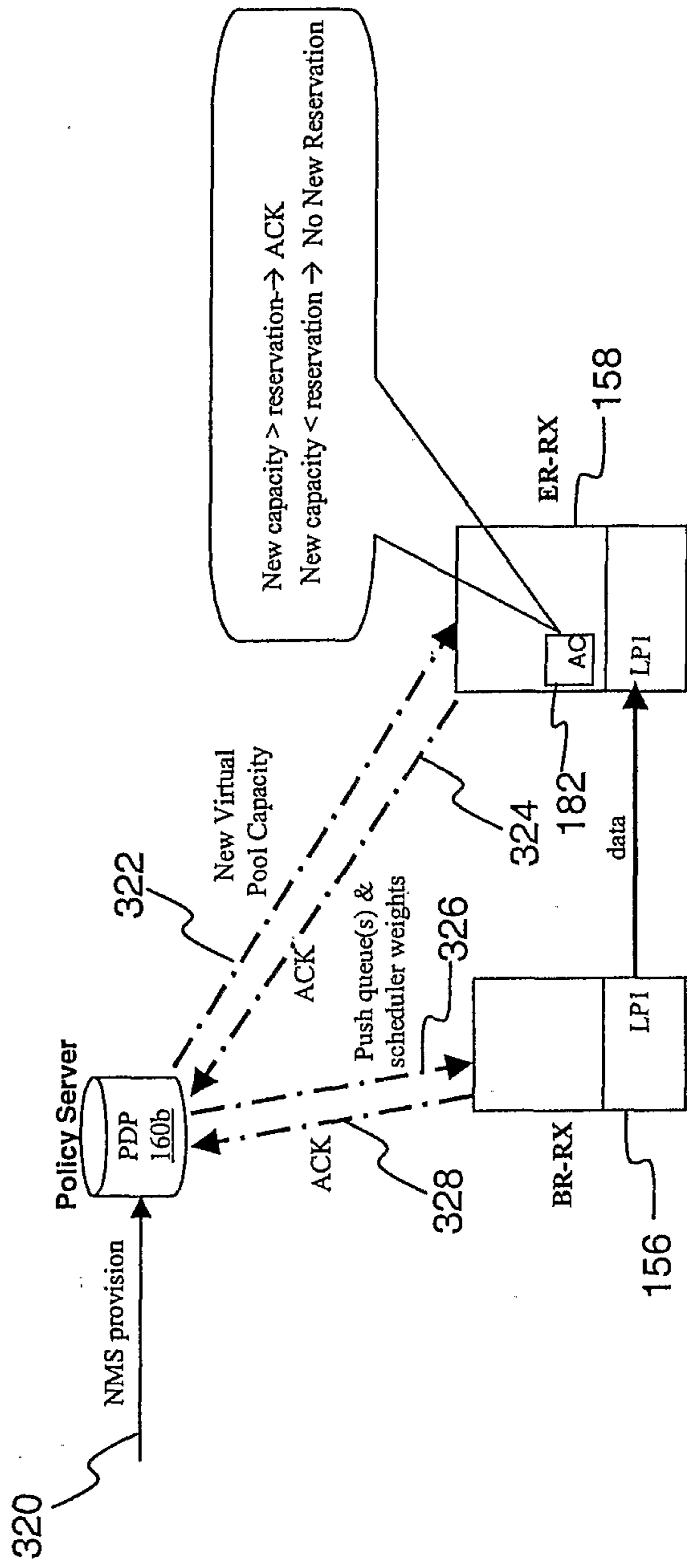

FIG. 8B

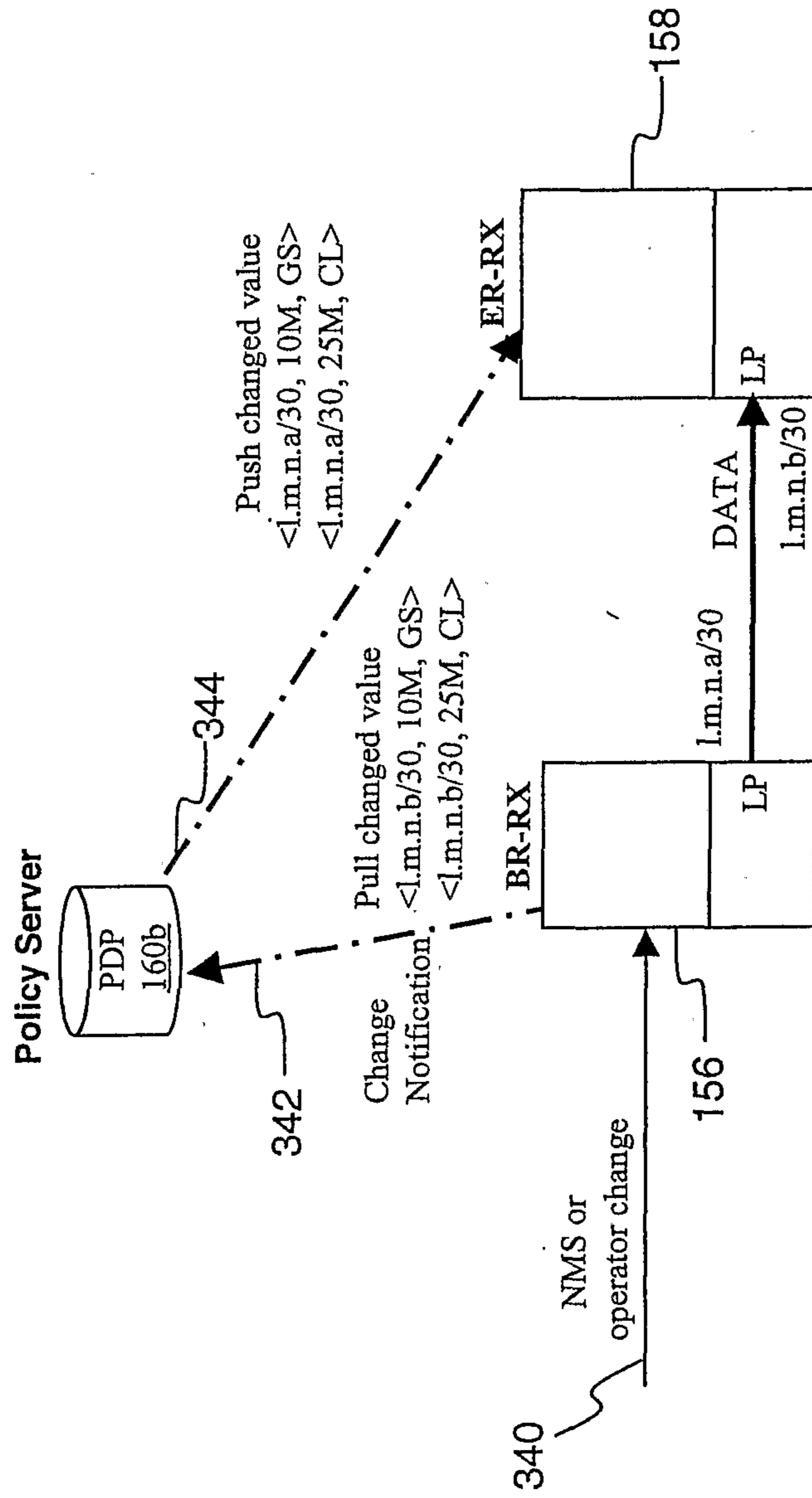
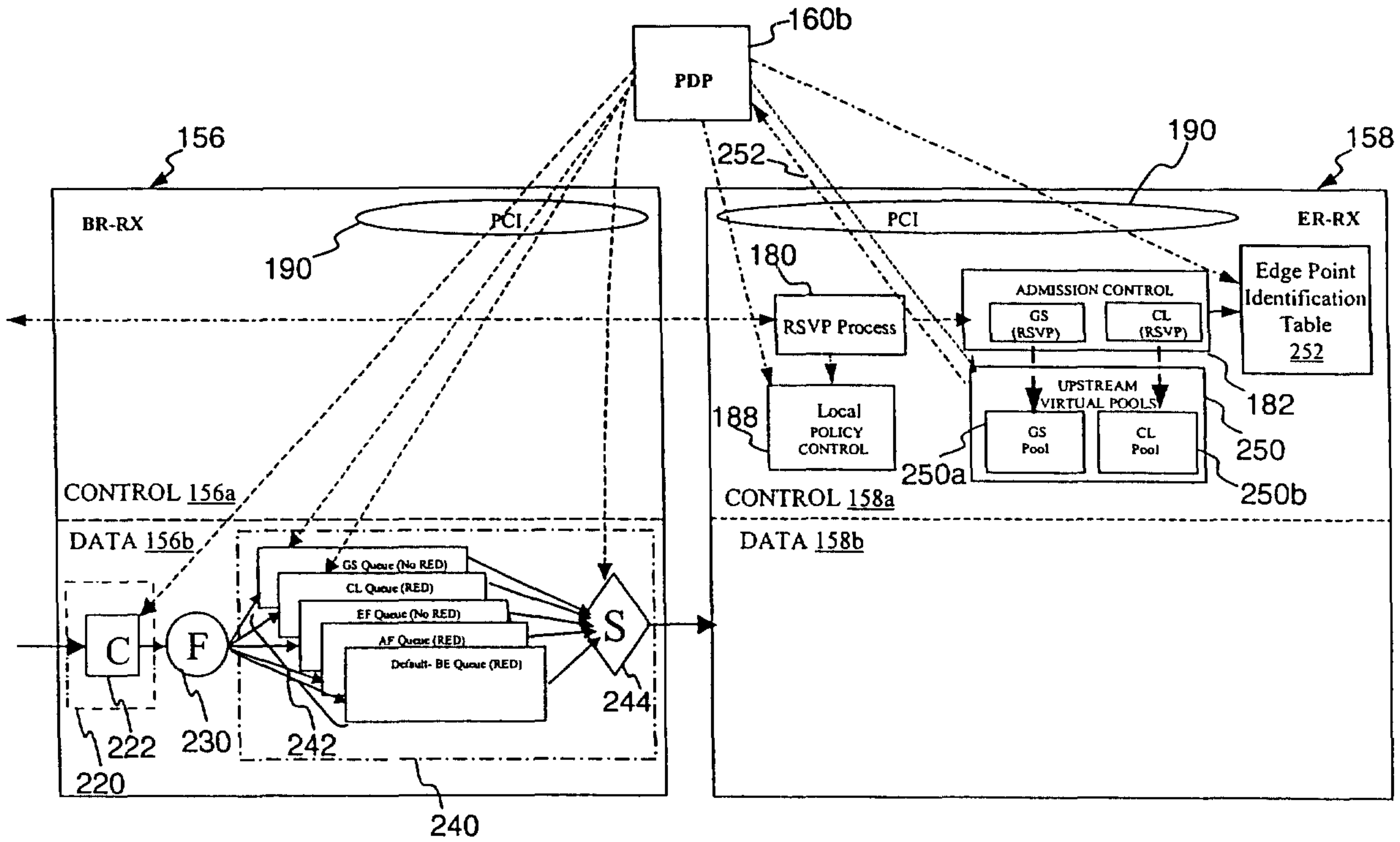

FIG. 8C



Unidirectional Traffic Flow