



INTERNATIONAL APPLICATION PUBLISHED UNDER THE PATENT COOPERATION TREATY (PCT)

(51) International Patent Classification ⁵ : B01D 43/00, B01J 19/10	A1	(11) International Publication Number: WO 94/26390 (43) International Publication Date: 24 November 1994 (24.11.94)
(21) International Application Number: PCT/IB94/00143 (22) International Filing Date: 11 May 1994 (11.05.94) (30) Priority Data: A 926/93 11 May 1993 (11.05.93) AT 08/086,700 2 July 1993 (02.07.93) US (71) Applicants (for all designated States except AT BE CH DE DK ES FR GB GR IE IT LU MC NL PT RU SE UA): CARLSON, David, V. [US/US]; 16211 N.E. 153rd Street, Woodinville, WA 98072 (US). SONOSEP BIOTECH, INC. [CA/CA]; # 120 - 13511 Commerce Parkway, Richmond, British Columbia V6V 2L1 (CA). (71)(72) Applicants and Inventors: TRAMPLER, Felix [AT/AT]; Schuerffgasse 7a/8, A-2340 Moedling (AT). BENES, Ewald [AT/AT]; Klosterstrasse 23, A-2362 Biedermannsdorf (AT). BURGER, Wolfgang [AT/AT]; Zehenthofgasse 19/1/15, A-1190 Wien (AT). GROSCHL, Martin [AT/AT]; Praterstrasse 35/18, A-1020 Wien (AT). (74) Agent: CARLSON, David, V.; Seed and Berry, 6300 Columbia Center, 701 Fifth Avenue, Seattle, WA 98104-7092 (US).		(81) Designated States: AU, BB, BG, BR, BY, CA, CN, CZ, FI, GE, HU, JP, KG, KP, KR, KZ, LK, LV, MD, MG, MN, MW, NO, NZ, PL, RO, RU, SD, SI, SK, TJ, TT, UA, UZ, VN, European patent (AT, BE, CH, DE, DK, ES, FR, GB, GR, IE, IT, LU, MC, NL, PT, SE), OAPI patent (BF, BJ, CF, CG, CI, CM, GA, GN, ML, MR, NE, SN, TD, TG). Published <i>With international search report.</i> <i>Before the expiration of the time limit for amending the claims and to be republished in the event of the receipt of amendments.</i>
(54) Title: MULTILAYERED PIEZOELECTRIC RESONATOR FOR THE SEPARATION OF SUSPENDED PARTICLES		
(57) Abstract <p>Particulate material suspended in a fluid is separated and recycled by means of an ultrasonic resonance wave. In a preferred embodiment, the ultrasonic resonance field is generated within a multilayered composite resonator system including a transducer, the suspension and a mirror parallel to each other. Dimensions and frequencies resonant to the whole system but not exciting Eigen-frequencies of transducer and mirror itself are chosen so that thermal dissipation is minimized. Generally, the process is suitable for all kinds of particles (solid, liquid or gaseous disperse phases) especially for hydrosols (particles in water) and for separation of biological particles such as mammalian, bacterial and plant cells or aggregates. Specialized applications in biotechnology are described including an acoustic filter for mammalian cell bioreactors or the selective retention of viable cells relative to non-viable cells.</p>		

FOR THE PURPOSES OF INFORMATION ONLY

Codes used to identify States party to the PCT on the front pages of pamphlets publishing international applications under the PCT.

AT	Austria	GB	United Kingdom	MR	Mauritania
AU	Australia	GE	Georgia	MW	Malawi
BB	Barbados	GN	Guinea	NE	Niger
BE	Belgium	GR	Greece	NL	Netherlands
BF	Burkina Faso	HU	Hungary	NO	Norway
BG	Bulgaria	IE	Ireland	NZ	New Zealand
BJ	Benin	IT	Italy	PL	Poland
BR	Brazil	JP	Japan	PT	Portugal
BY	Belarus	KE	Kenya	RO	Romania
CA	Canada	KG	Kyrgyzstan	RU	Russian Federation
CF	Central African Republic	KP	Democratic People's Republic of Korea	SD	Sudan
CG	Congo	KR	Republic of Korea	SE	Sweden
CH	Switzerland	KZ	Kazakhstan	SI	Slovenia
CI	Côte d'Ivoire	LI	Liechtenstein	SK	Slovakia
CM	Cameroon	LK	Sri Lanka	SN	Senegal
CN	China	LU	Luxembourg	TD	Chad
CS	Czechoslovakia	LV	Latvia	TG	Togo
CZ	Czech Republic	MC	Monaco	TJ	Tajikistan
DE	Germany	MD	Republic of Moldova	TT	Trinidad and Tobago
DK	Denmark	MG	Madagascar	UA	Ukraine
ES	Spain	ML	Mali	US	United States of America
FI	Finland	MN	Mongolia	UZ	Uzbekistan
FR	France			VN	Viet Nam
GA	Gabon				

Description

MULTILAYERED PIEZOELECTRIC RESONATOR FOR THE SEPARATION OF SUSPENDED PARTICLES

5

Technical Field

The present invention is related to a method and apparatus for separating particles dispersed in a liquid. The present invention is particularly directed to an acoustic resonator design having a transducer and a mirror, all
10 which are selected such that the resonation frequency of the resonator is different from an Eigen-frequency of the transducer. Generally, the process is suitable for all kinds of particles (solid, liquid or gaseous disperse phases) especially hydrosols (particles in water) as well for separation of biological particles such as mammalian, bacterial and plant cells or aggregates.

15

Background of the Invention

Numerous fields of modern technology require that particles be removed from fluid. Such separation processes permit either the liquid phase or particulate matter to be recycled. In biotechnology, biological particles have to
20 be removed from medium containing the product. Continuous stirred suspension bioreactors are operated with continuous addition of fresh medium and removal of spent medium, often containing the desired product. A number of systems have been developed to increase the cell density and productivity in these bioreactors by recycling cells from the spent medium stream. Of these systems,
25 spin filters are most widely commercially available. Spinning (rotation) of these cylindrical filters inside bioreactors helps reduce the fouling of the filter surface. Nonetheless, the usefulness of these existing systems is limited by progressive protein and cellular fouling of the filters. Filter fouling and the build-up of nonviable cells in the suspended phase of spin-filter bioreactors generally limits
30 the time of productive operation. The scale-up of spin-filters has been limited because, as the volume of bioreactors increases, it is not practical to provide enough filter area inside the reactor to maintain operation. Cross-flow, sedimentation and centrifugation systems are limited by fouling and scalability. They have not been widely used in industry. Centrifugation systems also have
35 not been widely used, possibly because of the high cost.

Recently, great effort has been directed at the development of acoustic separation methods to replace or enhance conventional technologies.

The establishment of a standing wave in the fluid results in the formation of velocity nodes or antinodes to which the particles are forced to migrate by the radiation force, depending on their compressibility and density. (Most solid and liquid particles move toward the velocity antinodes.) Nodes and antinodes are at
5 right angles to the direction of propagation of the sound waves, and the nodes are spaced from adjacent nodes by a distance equal to one half of the wavelength of the acoustic wave. The aggregating effect of ultrasonic sound within these antinodes has already been described in the literature. From E. Skudrzyk, "Die Grundlagen der Akustic," Springer Verlag, Wien, 1954, S. 202-205, S. 807-825;
10 L. Bergmann, "Der Ultraschall und seine Anwendungen in Wissenschaft und Technik," Verlag hirzel, Zuerich, 1954: as well as K. Asai and N. Sasaki, "Treatment of slick by means of ultrasonics," Proceedings of the 3rd International Congress on Coal Preparation, Institut National de l'Industrie Charbonniere, Brussels-Liege, 1958, it follows that the frequency to be used in
15 the applied sound is best chosen within the magnitude of the so-called characteristic frequency f_0 , which can be calculated from

$$f_0 = \frac{(3\eta)}{2\pi r^2} = \frac{0.48\eta}{r^2}, \quad (I)$$

whereby η constitutes the kinematic viscosity and r the radius of the particle.
20 Using this frequency range, the effect of radiation force and cumulative acoustically induced Bernoulli forces within the antinode planes can be maximized.

According to U.S. Patent No. 4,055,491, ultrasonic standing waves are used to flocculate small particles, such as blood or algae cells, within the
25 velocity antinodes of the acoustic field so that they settle out of the carrying liquid by gravity. But the undefined placement of the ultrasonic source and therefore low efficiency of the standing wave field due to undefined resonance boundary conditions result in high energy losses due to a considerable fraction of traveling waves. The described process is limited to discontinuous operations.
30 The apparatus presented in U.S. Patent No. 5,164,094 mainly modifies the geometry compared to the embodiments described in U.S. Patent No. 4,055,491. However, a considerable portion of energy is still lost since frequencies of the sound field applied to the vessels carrying the dispersion is not controlled by well-defined resonance boundary conditions.

An embodiment to separate particles with various acoustic qualities is described in U.S. Patent No. 4,523,682. A low resonance mode of a vessel containing a dispersion is excited by a relatively small transducer mounted at one end of the vessel, resulting in node and antinode planes perpendicular to the transducer/vessel interface. Perpendicular modes created by the acoustic point source mean that the system cannot be described as a one-dimensional resonator. The fraction of attenuated traveling waves in the longitudinal direction is high compared to the accumulated acoustic energy in the transversal standing wave field. Acoustic attenuation results in a temperature increase within the dispersion along the flow direction. Temperature changes affect sound velocity and resonance frequency, and cause a non-homogeneous temperature distribution along the flow direction which decreases the resonance quality of the field. As a result, the treatment period necessary to achieve the desired separation is prolonged.

Because of the long acoustic treatment periods necessary to achieve aggregation and sedimentation of the particles captured in the antinode planes, efforts were undertaken to move the antinodes of a standing wave relative to the dispersion, in order to obtain the desired separation effect directly by utilizing acoustic forces alone. U.S. Patent No. 4,673,512 introduces an interference standing wave field generated by opposing transducers which are excited with the same frequency. By controlling the phase shift between the electric excitation signals of the two acoustic sources, it is possible to move particles trapped within the antinodes or nodes of the traveling interference pattern in the dispersion. Using this method, a relatively short treatment period can be achieved. The disadvantage of this method is its non-resonant nature. Much more energy is used to maintain an interference standing wave field compared to a resonant standing wave field of the same amplitude. The result is higher electrical power consumption and thermal dissipation for producing a given acoustic particle velocity amplitude. The same problem has to be considered in U.S. Patent No. 4,759,775, in which only the method of creating the traveling interference pattern is different.

U.S. Patent No. 4,877,516 introduces the idea of the controlled movement of local gradients of the acoustic amplitude of the standing field perpendicular to the direction of sound propagation. Thus, particles are moved within the antinodes or nodes of the field by the Bernoulli-force which is directly related to described gradients and is acting parallel to the antinode planes. The disadvantage of the embodiment is the requirement of mechanically moving

array to produce acoustic shadows in order to achieve the desired movement of local gradients of the standing wave.

Stepwise movement of the antinodes of a resonant standing wave by exciting succeeding resonance modes of the resonator system is described in the PCT Appl. No. PCT/AT89/00098. Although resonance boundary conditions are fulfilled in some of the described embodiments, there is still considerably acoustically induced dissipation due to the resonator frequencies used, which have always been chosen very close to an Eigen-frequency of the transducer in the past.

10

Summary of the Invention

According to principles of the present invention, an ultrasonic resonance field is generated within a multilayered composite resonator system which includes a transducer, the suspension and a mirror. The suspension consists of a liquid containing particles to be separated. Acoustic radiation force moves the particles in the liquid towards the nodes or antinodes of the standing wave. Optionally, secondary lateral acoustic forces cause them to aggregate and the aggregates settle by gravity out of the liquid. If drifting resonance waves are used to separate the particles, secondary lateral forces to aggregate the particles may not be necessary.

20

The multilayered composite resonator system is designed such that the resonator as a whole has many resonance frequencies that are different from the Eigen-frequencies of the transducer and mirror. Preferably, the driving frequency of the transducer is selected to be a frequency that generates an acoustic standing resonance wave within the liquid but is offset from the Eigen-frequency of the transducer. The transducer is driven at a frequency different from its own Eigen-frequency, and in one embodiment, the driving frequency is halfway between two adjacent Eigen-frequencies of the transducer.

25

In biotechnology, cells are used to produce proteins of pharmaceutical importance. Most of these proteins require a further step in protein synthesis called post-translational modification. Mammalian cells rather than bacteria are used to produce these proteins because only they can achieve such complicated modifications. The protein products of most mammalian cells are secreted into the medium. For batch bioreactors, cells have to be separated from the medium after a run. For continuous flow reactors, cells can be recycled back to the bioreactor to increase productivity. Ultrasonically induced aggregation and sedimentation is applicable to both continuous flow suspension

35

bioreactors and downstream processing. The mammalian cells are thus separated from the liquid culture in which they are grown and kept in the bioreactor while permitting harvesting of the protein from the liquid.

To avoid any misunderstanding in the comparison of the prior art with the invention, the following definitions are presented to clarify their use strictly throughout this description.

"Acoustic particles" are simply the volume elements of the acoustic continuum theory and must not be confused with the suspended particles. The "acoustic particle velocity" is the time derivative of the periodic acoustic particle displacement caused by the regarded sound wave.

"One-dimensional" treatment of composite resonators means, that an approximate model is applied, where all quantities are regarded as being exclusively dependent from only one direction (compare, e.g., H. Nowotny, E. Benes, and M. Schmid, *J. Acoust. Soc. Am.* 90(3), September 1991). This direction is coinciding throughout this description with the longitudinal direction.

The term "layer" is very generally used. Even the liquid carrying the suspended particles is regarded as a layer. This essential resonance frequency-determining dimension is usually, but not necessarily, the thickness dimension of the layer. The x-axis of the coordinates is chosen in the direction of this layer dimension, perpendicular to the flow direction. The y-axis direction is the depth of the layer and is perpendicular to the x-axis direction and to the flow direction. The z-axis direction is parallel to the fluid flow direction.

"Active layers" consist of piezoelectric material, "passive layers" consists of non-piezoelectric material.

"Transducer" is in the most simply case a single layer of a piezoelectric material. For many reasons it is advantageous to bond several piezoelectric plates with one or on both sides upon passive, electrically insulating carrier layers. According to the invention, additional transformation (sub)layers may be used. The transducer-layer itself consists in the most general case of a number of solid layers, whereby the piezoelectric layer is contained and the outermost layers are in contact with the surrounding air or the dispersion layer(s), respectively.

"Phase shift φ " is the spatial phase shift of the acoustic particle velocity V :

35

$$\varphi = 2\pi \cdot f_e \frac{x}{v} \quad (\text{II})$$

where f_e is the electrical driving frequency, x is the resonance determining dimension of the regarded layer, and v is the sound (phase) velocity of the regarded layer. The total phase shift of a multilayer is the sum of the phase shifts of each layer and the additional phase jumps at the interface planes between adjacent layers with different specific acoustic impedances. The delta phase shift $\Delta\phi$ refers to the phase shift changes of the standing wave over its entire length in the acoustic resonance chamber containing the fluid. A change of 180° is a phase shift of π , a change of one full wave is a phase shift of 2π , whereas a change of 90° and 45° is a phase shift change of $\pi/2$ and $\pi/4$, respectively.

"Harmonic Eigen-frequencies" or the harmonic resonance frequencies, f_i , of a single layer are defined by

$$f_i = \frac{i \cdot \left(\frac{c}{p}\right)^{1/2}}{2 \cdot x} \quad (\text{III})$$

where i is the number of the regarded harmonic frequency, x is the resonance determining dimension, c is the effective elastic constant, and p is the mass-density of the layer.

If the layer is consisting of a piezoelectric material, the effective elastic constant c in equation (III) depends upon the electrical load between the electrodes. For the limit cases of short-circuited and open-loop electrodes, the so-called series or parallel Eigen-frequencies are determined, respectively. Only an odd subset of the Eigen-frequencies f_i can be electrically excited.

"Quasi-harmonic Eigen-frequencies" of a multilayer (e.g., a multilayered transducer). While the overtone frequencies of a single homogeneous layer are integer multiples of the fundamental Eigen-frequency, the overtone-frequencies of a composite resonator are in general not that trivially spaced. For that reason, the Eigen-frequencies of a one-dimensional composite resonator are sometimes called "quasi-harmonic resonance frequencies." (Compare, e.g., E. Benes, *J. Appl. Phys.* 56(3), 1 August 1984). However, in the case of one layer with dominating dimension (dispersion layer), in a first approximation also the high overtone composite frequencies may be regarded as equidistant. Since a transducer according to the invention usually consists of more than one single layer, it is a multilayered resonator itself. For such a

resonator, the Eigen-frequencies can be defined as the frequencies for which the phase shift φ_T of the acoustic particle velocity amplitude along the dimension x_T of the transducer between the outermost planes is equal to an integer multiple n of the number π . Not all of these mechanically possible resonance frequencies are piezoelectrically excitable. The excitability depends on the displacement curve along the active layer alone. If this curve is a symmetric one, the transducer is not excitable at the corresponding frequency. This definition of the electrically excitable Eigen-frequencies of a multilayered transducer corresponds with the measurable resonance frequencies, if the transducer is surrounded by vacuum (or air) and the frequency of the driving electrical power generator is tuned to the relative maxima of the electrical active power consumed by the resonator. If the voltage amplitude U_e of the driving power generator is kept constant (very low electrical source impedance), the so-called series resonance frequency of the composite structure is determined. If the current amplitude I_e of the driving power generator is kept constant (very high electrical source impedance), the so-called parallel resonance frequency of the composite structure is determined.

"Longitudinal direction" means the direction of the layer thickness dimension. The longitudinal direction coincides with the propagation direction of the sound wave excited by the transducer layer. According to the present invention, resonance modes of the composite resonator are excited in longitudinal direction. Therefore, the direction of the standing resonance wave is referred to as the longitudinal direction.

"Resonance frequencies f_C of the multilayered composite resonator" result from the condition for longitudinal resonance, whereas the total phase shift φ_C of the acoustic standing wave across the total length of a composite resonance system, including all layers, has to be an integer multiple of the number π . This definition of the resonance frequencies of the composite resonator corresponds with the measurable resonance frequencies if the frequency of the driving electrical power generator is tuned to the relative maxima of the electrical active (root mean square) power consumed by the resonator.

"Eigen-frequencies f_T of the transducer" result from the condition that the phase shift φ_T between the terminating planes of the transducer layer has to be an integer multiple m of the number π . This definition of the Eigen-frequencies of a transducer corresponds with the measurable resonance frequencies, if the transducer is surrounded by vacuum (or air) and the frequency of the driving

electrical power generator is tuned to the relative maxima of the electrical active power consumed by the resonator. Generally, the transducer may consist of several layers. If the transducer is formed by a single piezoelectric layer covered with electrodes, the condition for Eigen-frequencies is given by

5

$$\varphi_T = 2\pi \cdot x_T \cdot f_{T,m} / v_T(q,m) = m \cdot \pi, \quad (IV)$$

whereby m is the number of the regarded Eigen-frequency $f_{T,m}$; x_T is the resonance determining thickness; and v_T is the longitudinal sound velocity of the transducer, which is depending on the electrical charge q at the electrodes and the number m of the regarded Eigen-frequency.

10

"Eigen-frequencies f_M of the mirror" result from the condition that the phase shift φ_M between the surfaces of the reflector layer has to be an integer multiple n of the number π . If the mirror is formed by a single layer only, the condition for Eigen-frequencies is given by

15

$$\varphi_M = 2\pi \cdot x_M \cdot f_{M,n} / v_M = n \cdot \pi, \quad (V)$$

whereby n is the number of the regarded harmonic Eigen-frequency $f_{M,n}$, x_M is the resonance determining thickness, and v_M the longitudinal sound velocity of the mirror.

20

"Transversal directions" are directions perpendicular to the longitudinal direction. These directions fall in the particle velocity node and antinode planes of the standing resonance wave.

25

"Specific acoustic impedance Z " is the acoustic impedance per cross-sectional area of the regarded material.

The present invention is directed to a method and apparatus capable of continuously separating and recycling dispersed particles with acoustic properties (compressibility, sound velocity) different than the suspension medium. The methods of the present invention use acoustically induced forces to retain and aggregate dispersed particles and gravity to settle and recycle the aggregates.

30

According to the preferred embodiments, the multilayered composite resonator system consists of a plane transducer, a vessel containing the dispersion and a plane acoustic mirror. All acoustically coupled layers are arranged in longitudinal direction and their surfaces are parallel to each other. The transducer may consist of a piezoelectrically active layer, such as PZT

35

(Lead-Zirconate-Titanate) ceramics or Lithium-Niobate monocrystals or PVDF layers, and a solid passive layer acting as carrier of the active layer.

All acoustically coupled layers are parallel to each other. The invention is suitable to separate dispersed particles, with sizes ranging from 10^{-3} to 1 mm. Preferred resonance frequencies according to acoustic and geometric properties of the particles range from 0.1 to 10 MHz.

The invention provides an ultrasonic resonance field between transducer and a mirror of a multilayered composite acoustic resonator, capable of separating and recycling particles from fluid, while minimizing the effect of any temperature increase caused by acoustically induced dissipation. Many potential applications for ultrasonic separation processes (for example in biotechnology) require a separation method where temperature increases are minimized in order to avoid thermal damage to the particles. Furthermore, the accumulated energy of the established acoustic resonant field and therefore the acoustic treatment time necessary to achieve separation depends on a homogeneous temperature distribution along the flow direction perpendicular to direction of sound propagation. Because the wavelength of an acoustic wave is partially dependent on temperature, an undesired spatial temperature gradient along flow direction perpendicular to the longitudinal direction of the standing wave results in a non-homogeneous distribution (in flow direction) of the total phase shift of the acoustic wave between the terminating planes of the composite resonator. Defined and constant phase total shift distribution in transversal directions of the composite resonant system is a boundary condition for maintaining high quality resonance fields. Therefore, thermal dissipation has to be minimized and flow velocity of the suspension optimized.

The first alternative embodiment of a first feature will now be summarized. According to principles of a first embodiment of one feature of the present invention, acoustically induced thermal dissipation of transducer and mirror within a composite resonator system are minimized by only exciting longitudinal acoustic resonance frequencies f_C of the multilayered composite resonator, which are not in the range of any of the Eigen-frequencies f_T of the transducer or f_M of the mirror. Generally, the electrical excitability of a transducer at one of its Eigen-frequencies is much higher than its electrical excitability between adjacent Eigen-frequencies. As a result, in the prior art, a transducer has always been excited close to one of its Eigen-frequencies to generate a standing wave within the suspension. This has resulted in considerable thermal dissipation of the transducer in the prior art.

According to one first feature of the invention, avoiding excitation of any of the Eigen-frequencies of the transducer layer or mirror layer is helpful for choosing the layer-thicknesses and the frequency f_e of the electrical signal exciting the transducer. Lower electrical excitability of the transducer at such
 5 excitation frequencies is of less importance, if resonance conditions within the multilayered resonator are maintained. Resonance frequencies f_C of the composite resonator result from the condition for longitudinal resonance, whereas the total phase shift φ_C of the acoustic standing wave across the total
 10 length of a composite resonance system, including all layers, has to be an integer multiple of the number π .

In order to avoid excitation of any of the Eigen-frequencies of the transducer, the thickness x_T of the transducer is of a value, which causes a spatial phase shift φ_T of the acoustic particle velocity amplitude of the generated acoustic wave close to, or equal to, an odd multiple of the number $\pi/2$. In other
 15 words, the exciting frequency f_e of the power generator driving the transducer is tuned toward such a high-overtone resonance frequency of the composite resonator f_C , which is close to the average of two adjacent Eigen-frequencies $f_{T,m}$, $f_{T,m+1}$ of the transducer:

$$20 \quad f_C \cong (f_{T,m} + f_{T,m+1})/2 \quad (\text{VI})$$

The transducer may consist of a piezoelectric layer, referred to as active layer, such as PZT (Lead-Zirconate-Titanate) ceramics, Lithium-Niobate monocrystals, or PVDF layers, and a solid non-piezoelectric layer, referred to as
 25 passive layer, acting as a carrier of the active layer. The carrier material has a specific acoustic impedance Z_B in the range of the acoustic impedance of the piezoelectrically active layer Z_A .

The mirror consists of a material with a specific acoustic impedance Z_M which is high compared to the specific acoustic impedance Z_S of the suspension. Similar to the transducer, the thickness x_M of the mirror is
 30 chosen to be of a value which causes a spatial phase shift φ_M of the acoustic particle velocity amplitude close to, or equal to, an odd multiple of the number $\pi/2$. In other words, the exciting frequency f_e is tuned towards such a high-overtone resonance frequency of the composite resonator f_C , which is close to
 35 the average of two adjacent Eigen-frequencies $f_{M,n}$, $f_{M,n+1}$ of the mirror:

$$f_C \cong (f_{M,n} + f_{M,n+1})/2 \quad (\text{VII})$$

The suspension liquid may inadvertently be heated by a number of different phenomena. Heating of the suspension liquid has been found to create a problem in those systems that rely on an acoustic resonance standing wave.

5 Generally, sound velocity v_S within the suspension depends on temperature T of the suspension. Thus, the phase shift φ_S of the acoustic wave between transducer and mirror varies with temperature, too:

$$\varphi_S(T) = 2\pi \cdot x_S \cdot f_e / v_S(T), \quad (\text{VIII})$$

10

whereby x_S is the thickness of the suspension layer and f_e the exciting frequency. In summary, temperature changes in the liquid cause a phase shift change in the acoustic wave.

For those systems in which there is a flow, the flow is defined as perpendicular to the direction x of the acoustic wave and parallel to the direction z . A temperature distribution $T_S(z)$ in direction z , averaged in direction x , causes a non-homogeneous distribution $\varphi_S(z)$ of spatial phase shift of the acoustic wave within the suspension layer. This relationship is, in first approximation, best described by

20

$$\Delta\varphi_S = \varphi_S(T) \cdot \alpha(T) \cdot \Delta T \quad (\text{IX})$$

and results from the equation (VIII). The coefficient $\alpha = - (1/v_S) \cdot (\partial v_S / \partial T)$ describes the dependency of sound velocity v_S on temperature T and can be determined experimentally. The temperature range ΔT within the resonator can be calculated from inflow temperature minus outflow temperature. The resulting range of phase shift $\Delta\varphi_S$ prevents a high quality factor Q_S of the suspension layer, which can only be achieved if the phase shift φ_S is constant in transversal direction z . Q_S is defined by

30

$$Q_S = 2\pi \cdot E_S / W_S, \quad (\text{X})$$

whereby the accumulated acoustic energy E_S of the resonance field within the suspension is responsible for acoustic forces acting on the dispersed particles and causing them to aggregate. W_S indicates the portion of acoustic energy attenuated by the suspension within the time period $1/f_C$. This attenuation is responsible for thermal dissipation within the suspension.

35

As a result, temperature gradients in flow direction z perpendicular to direction x of the standing wave lower the quality factor Q_S and thus, lower the accumulated acoustic energy E_S of the resonance field within the fluid. Decrease of the accumulated acoustic energy E_S may suggest that prolonged
 5 treatment time is necessary to achieve acoustically induced aggregation and separation of the particles. If one decides to lower the flow velocity to prolong treatment time this results in an even larger temperature gradient along flow direction. Ultimately, quality factor Q_S vanishes and the resonance field collapses completely at too low flow rates.

10 The embodiment in which the transducer and resonator chamber are designed such that the resonant frequency for the resonator chamber is different from the harmonic frequency (Eigen-frequencies) of the transducer and mirror has been briefly described with respect to equations II, III, IV, V, VI, VII and the text associated therewith. This inventive design tends to minimize the
 15 heating of the suspension's liquid caused by the transducer itself being heated. These features will now be summarized in greater detail.

According to one of the preferred embodiments, the multilayered composite resonator system consists of a plane transducer, a vessel containing the dispersion and a plane acoustic mirror. All acoustically coupled layers are
 20 arranged in longitudinal direction and their surfaces are parallel to each other. The transducer may consist of a piezoelectrically active layer, such as PZT (Lead-Zirconate-Titanate) ceramics or Lithium-Niobate monocrystals or PVDF layers, and a solid passive layer acting as carrier of the active layer. The invention is suitable to separate dispersed particle sizes ranging from 10^{-3} to
 25 1 mm. Preferred resonance frequencies according to acoustic and geometric properties of the particles range from 0.1 to 10 MHz.

As a result of the present invention, the loss characterizing figure $R = W_e/E_S = P_e \cdot \tau_{Cj}/E_S$ is minimized. The loss figure R is defined as the ratio between the active electrical energy consumption W_e (per period $\tau_{Cj} =$
 30 $1/f_{Cj}$) of the composite resonator system and the reactive accumulated acoustic energy E_S of the resonance field in the fluid; f_{Cj} is the excited quasi-harmonic resonance frequency of the composite resonator. P_e describes the active (root mean square) electrical power input,

35
$$P_e = \frac{1}{2} U_e I_e \cos \phi, \quad (\text{XI})$$

whereby U_e , I_e are the amplitudes of the driving voltage and current, respectively, ϕ is the phase between both.

The accumulated acoustic energy E_S is directly related to the acoustic forces acting on the particles, whereby the energy consumption W_e compensates for attenuation of the acoustic field causing thermal dissipation. A small portion of W_e also represents dielectric losses of the transducer, which are of no relevance to the present invention and will not be mentioned further.

Acoustically induced thermal dissipation of transducer and mirror can be minimized by exciting an acoustic quasi-harmonic composite resonance frequency f_{Cj} of the total resonator, but simultaneously mismatching the driving frequency f_e with any of the quasi-harmonic Eigen-frequencies f_{Ti} of the transducer as well as with any of the Eigen-frequencies f_{Mk} of the mirror. As a consequence, the characterizing loss figure R is significantly reduced. This mismatching between driving frequency and Eigen-frequency of the transducer is not at least obvious, since in the mismatched case the composite resonator shows a rather poor electrical behavior. For example, in the locus of electrical admittance curves, the composite resonances, which are represented by circles, are much less recognizable. The resonance circles appear to be much smaller and are offset from the real axis. Because of these properties, in the general case it is much more difficult to design an electrical driving electronics for maintaining a resonance excitation offside a transducer Eigen-frequency. For that reason, in the prior art systems the excitation of a composite resonator has been performed always close to the fundamental or third quasi-harmonic Eigen-frequency of the transducer.

Composite resonance frequencies f_{Cj} result from the boundary condition at the terminating, total reflecting surfaces of a composite resonator for a standing wave, whereas the maximum of the acoustic particle velocity amplitude has to coincide with the terminating planes. Therefore, the total phase shift ϕ_C across the total length x_C of a multilayered composite resonance system in longitudinal direction, including all layers, has to be an integer multiple of the number π . Mismatching between the electrical driving frequency f_e and the Eigen-frequencies f_{Ti} of the transducer layer can be obtained for a given driving frequency either by proper choosing the transducer thickness x_T and its relative position within the multilayered resonator, or by directly choosing the driving frequency equal to a composite resonance frequency which is sufficiently off-set from any excitable Eigen-frequency of the transducer.

According to one embodiment of the invention, the offset is sufficient, if it is chosen higher than a certain minimum offset. The minimum offset is equal to 10% divided by the quasi-harmonic number i of the regarded Eigen-frequencies f_{Ti} of the transducer:

5

$$0 < f_e < [0.9 f_{T1}] ; [1.1 f_{T1}] < f_e < [(1-0.1/2) f_{T2}] ; [(1+0.1/2) f_{T2}] < f_e < [(1-0.1/3) f_{T3}] ; [(1+0.1/3) f_{T3}] < f_e < [(1-0.1/4) f_{T4}] ; [(1+0.1/4) f_{T4}] < f_e < \dots \quad (\text{XII})$$

Thus, if the number i of the Eigen-frequency is 1, the offset is at least 10%/1 or 10%; if the number i is 2, the offset is at least 10%/2 or 5%; similarly, if the number i is 3, the offset is at least 10%/3 or 3.33%, and so on. By introducing this mismatching, the coincidence of the maxima of the acoustic particle velocity amplitude with both outermost transducer planes is avoided. The characterizing loss figure R is optimized, if the thickness x_T and relative position of the transducer layer being chosen with regard to the driving frequency f_e in such a way that a vanishing acoustic particle velocity amplitude V in the interface plane between transducer and the dispersion is obtained. In this preferred case, the mismatching between the driving frequency f_e and all the excitable Eigen-frequencies f_{Ti} of the transducer is maximal and the driving frequency f_e is approximately in the middle of one of the allowed intervals defined in equation (XII).

Similar rules are valid for the mirror layer. The thickness x_M of the mirror layer has to be properly chosen in order to avoid excitation of its Eigen-frequencies f_{Mi} . The relative position of the mirror layer, however, is fixed as terminating reflecting layer of the multilayered resonator. Generally, the mirror may also consist of several layers.

The transducer layer may form a terminating layer of the composite resonator. Furthermore, the transducer layer may consist of a piezoelectrically active layer, such as PZT (Lead-Zirconate-Titanate, $\text{Pb}(\text{Ti,Zr})\text{O}_3$) ceramics, or Lithium-Niobate (LiNbO_3) monocrystals, or PVDF (Polyvinylidene Fluoride) polymers, and a solid passive layer acting as a carrier of the active layer with defined thickness to achieve low acoustically induced thermal dissipation. Best results can be achieved by using a carrier material with low acoustic attenuation and with a specific acoustic impedance Z_B in the range of or higher than the specific acoustic impedance Z_A of the piezoelectrically active layer. The thickness x_A of the active layer is preferably of a value which causes a phase shift ϕ_A close to or equal to an odd multiple m of the number π .

The thickness of the passive layer x_B is preferably of a value which causes a phase shift ϕ_B being close to or equal to an odd multiple of half of the number π . Using these criteria, the acoustic particle velocity amplitude at the transducer/liquid interface approaches zero and the boundary condition for exciting an Eigen-frequency f_{Tj} of the transducer is optimally avoided. As a result, energy dissipation of the transducer is minimized. Besides that, for this preferred arrangement, there is no decrease of excitability compared to the case of matching the driving frequency and one of the Eigen-frequency of a transducer.

The transducer layer can also be positioned between two dispersion layers. In that case, the thickness x_A of the active layer is preferably of a value which causes a phase shift ϕ_A close to or equal to an odd multiple m of the number π . The thicknesses of the passive layers x_B, x'_B (if any) on each side of the transducer are preferably of values which cause phase shifts ϕ_B, ϕ'_B being close to or equal to an odd multiple n, n' of half of the number π , respectively. Furthermore, the thicknesses of the dispersion layers x_S, x'_S and mirror layers x_M, x'_M on each side of the transducer have to be chosen, so that the acoustic particle velocity amplitude at both transducer/liquid interfaces approaches zero and the boundary condition for exciting an Eigen-frequency f_{Tj} of the transducer is maximally avoided. As a result, the energy dissipation of the transducer is minimized. Preferably, the thicknesses x_B, x'_B of the passive layers, are equal and the layers are made of the same material.

An odd multiple q of passive sublayers, each of a thickness $x_{B,k}$ ($k = 1 \dots q$) causing a phase shift $\phi_{B,k}$ as described above for the thickness x_B of a single passive layer, with alternating high (in the range of the active layer) and low (in the range of the dispersion) acoustic impedance, but starting and ending with high ones, is useful to further reduce energy dissipation when this ensemble of sublayers is arranged between the active layer and dispersion. Alternatively, low-impedance sublayers can also be formed by a liquid with low acoustic attenuation, optionally circulating in order to control temperature.

Since the frequencies f_{Cj} of the resonance modes of the composite system vary with temperature of the fluid and particle concentration it is of significance to compensate the exciting frequency f_e for resonance frequency drifts in order to maintain constant conditions according to the aim of the invention. This can be achieved by controlling the fine tuning of the exciting frequency f_e by an automatic frequency control (AFC) which maintains the

active electrical power consumption P_e of the composite resonator at a relative maximum as criterion for resonance.

Another approach to control the exciting frequency f_e towards a preferred resonance frequency f_{Cj} is to provide an additional active layer (e.g.,
5 PZT ceramics, Lithium-Niobate monocrystals, or PVDF layers) as mirror or as part of a composite mirror and to utilize the amplitude of the acoustically induced electrical signal at the electrodes of this said active layer as control criterion for maintaining the excitation of the chosen composite resonance frequency f_{Cj} .

10 Similar to the thicknesses of the layers of a composite transducer, the thicknesses of the piezoelectrically active and passive layers of a composite mirror are advantageously chosen so that the acoustic particle velocity amplitude at the mirror/liquid interface approaches zero and the boundary condition for exciting an Eigen-frequency f_{Ti} of the transducer is optimally avoided. As a
15 result, we have found that energy dissipation of the mirror is minimized for a given acoustic particle velocity amplitude in the fluid.

Analogous to the sublayers of a transducer as described above, sublayers can be introduced in a composite mirror layer. An odd multiple q of passive sublayers of a composite mirror, each of a thickness $x_{B,k}$ ($k = 1 \dots q$)
20 causing phase shifts $\varphi_{B,k}$ as described above for a transducer, arranged between active layer of the mirror (if any) and fluid layer, with alternating high (in the range of the active layer) and low (in the range of the dispersion) acoustic impedance, but starting and ending with high ones, can be used according to the invention to further lower energy dissipation.

25 The invention of this application is defined by the appended claims and is not limited to just the preferred embodiments of transducer designs described herein. A patent application has been filed in Austria on May 11, 1993 bearing Application Number A 926/93 that describes and claims the subject matter of this invention and priority is claimed for such filing. A related
30 application is being filed concurrently herewith bearing U.S. Serial No. _____, filed on July 2, 1993, naming as inventors Felix Trampler, James M. Piert, Stefan A. Sonderhoff, and Douglass G. Kilburn. These two applications have one common inventor, Felix Trampler, and cover related subject matter. For a more complete understanding, the subject matter of the related U.S.
35 application Serial No. _____, filed concurrently herewith, will now be summarized.

The alternative embodiment avoids the lowering of the quality factor Q_s by setting a lower limit of flow velocity, according to the present invention. The lower limit flow velocity is selected to be of a value, which results in a phase shift distribution $\phi_S(z)$ within the suspension layer having a total range $\Delta\phi_S$ of less than one quarter of π . Generally, if only prior art techniques are used, there is a possibility that this flow criterion may result in a retention time of the suspension inside the acoustic resonance field too short to aggregate particles sufficiently to allow sedimentation. According to one embodiment of the present invention the flow direction is oriented against the force of gravity. As soon as acoustically induced aggregation occurs, gravity becomes a dominant force and compensates for Stokes drag force (which is responsible for moving the dispersed particles within the fluid in flow direction) and causes the particles to not be advanced by the liquid. Due to acoustically induced Bernoulli forces acting in transversal directions to the direction of the standing wave, particles are trapped within the antinode planes of the resonance field as the liquid passes through the composite resonator. This results in considerably higher effective retention times of suspended particles inside the resonance field compared to the retention time of the fluid. Furthermore, particle concentration of the suspension is increased within the acoustic resonance field enhancing aggregation. Once the aggregates become large enough to overcome the fluid drag and acoustically induced Bernoulli forces, they settle out of the liquid under the force of gravity, against the flow.

The inflow pipe of the resonator is, preferably, also the settling tube with inner dimensions limited by the preferably square shaped (x,y) cross section of the suspension layer to keep flow velocity within the settling tube low. Maximizing the inflow/settling tube diameter minimizes the flow velocity within the tube.

According to one embodiment of the present invention, turbulence inside the settling tube is minimized by at least two sets of baffles. The (x,y) cross section (perpendicular to flow direction z) of such a set is grid shaped. The relatively low grid frequency ranging between 1.5 to 5 cm^{-1} avoids breaking up settling aggregates. A multiple of sets of baffles placed inside the tube prevents turbulence more effectively than a single set of multiple length. If required, a single pass shell and tube heat exchanger could replace one set of baffles to precool fluid before entering the resonator.

In addition, the invention presents another alternative approach to overcome the decrease of resonance quality caused by temperature gradients

along flow direction. The suspension layer is divided into at least two sections by an acoustically transparent layer perpendicular to the direction x of the standing wave and referred to as film layer. The liquid flows through adjacent sections S_i essentially in opposite flow orientation z , $-z$, with flow velocities
5 resulting in temperature distributions $T_i(z)$ in the regarded section S_i . The temperature distributions $T_i(z)$ result in a temperature distribution $T(z)$ in direction z , averaged in direction x across all suspension sections S_i . This temperature distribution $T(z)$ causes the non-homogeneous distribution $\phi_S(z)$ of spatial phase shift of the acoustic wave within the suspension to be within a total
10 range $\Delta\phi_S$ of less than one quarter of π . Therefore, the effects of temperature gradients in flow direction caused by acoustically induced dissipation are compensated for by counter flow.

Furthermore, according to another alternative embodiment of the invention, the piezoelectrically active layer of the transducer can be formed by at
15 least two adjacent piezoelectric plates and, thus, be divided into at least two independent segments. Each transducer is bonded onto the passive layer and excited by an individual electrical power generator. The non-homogeneous temperature distribution $T(z)$ as described above causes individual resonance frequencies of each of the standing waves within the resonator created by the two
20 separate transducers. Using two or more transducers has the advantage that the flow velocity criterion does not have to be fulfilled for the entire flow path of the suspension within the resonator, but only within each regarded segment of the resonator associated with each transducer, respectively. Furthermore, individual periods of excitation of the piezoelectric transducers can be interrupted by
25 periods of no excitation of one of them to allow controlled settling of aggregates within the regarded segments of the resonator. When the acoustic resonance field of one segment is switched off, the remaining resonance fields of adjacent segments remain on and prevent remixing.

A variation of the present invention is the so-called two-
30 dimensional resonator system, possibly acting as an additional step to the described one-dimensional resonator system to separate low particle concentrations from a liquid. The two directions of a two-dimensional resonance field are preferably perpendicular to each other. Perpendicular acoustic radiation forces result in the migration of suspended particles towards the intersection
35 lines of the antinode planes of each of the two one-dimensional resonance fields. Higher particle concentrations can be achieved at these intersection lines than within a single antinode plane. To achieve acoustically induced aggregation, a

minimum particle concentration is required. Therefore, the higher particle concentration at the antinode lines of a two-dimensional field result in a lower supernatant particle concentration within the liquid at the outflow.

5 Since the frequencies f_C of the resonance modes of the composite system vary with temperature of the fluid and its particle concentration, it is necessary to compensate the exciting frequency f_e for resonance frequency drifts. This can be achieved by controlling the fine tuning of the exciting frequency f_e by an automatic frequency control (AFC) which utilizes a relative maximum of the active electrical power consumption P_{e1} of the composite resonator as criterion for resonance. Another approach to control the exciting frequency f_e towards a preferred resonance frequency f_C is to maximize the acoustically induced electrical signal in a piezoelectrically active layer (e.g., PZT ceramics, Lithium-Niobate monocrystals, or PVDF layers) used as mirror or included in a composite mirror.

15 One application of the present invention is its use in the separation from nutrient medium and recycling of cultured mammalian cells grown in a perfused stirred tank bioreactor chamber. Retention of cells within the bioreactor chamber and the ability to continuously replenish nutrient medium allows growth to occur up to high cell densities. The settling tube, which also may be the inflow tube, is directly connected to the bioreactor chamber. The pump is preferentially placed after the outlet side of the resonator chamber to avoid mechanically damaging the recycled cells. The maximum acoustic particle velocity amplitude within the suspension is also maintained at a value that will not result in damage to the cells. The preferred resonance frequency f_C of the composite resonator ranges between 2 to 4 MHz. If required, the flow velocity of the suspension can be tuned to result in a significantly higher separation efficiency for viable cells than for non-viable cells. This effect is due to the different diameters and compressibilities of viable and non-viable cells, which results in weaker acoustic forces acting on non-viable cells compared to viable cells. The selective concentration of viable cells results in increased culture viability, a major advantage over existing cell recycling technologies which tend to accumulate non-viable cells within the bioreactor chamber. For the purposes of this example, separation efficiency is hereby defined as the ratio of the number of cells being separated from the liquid by acoustically induced aggregation and sedimentation to the number of cells entering the resonator within the same period of time. Viability is hereby defined as the ratio of viable cells to the total number of cells. Materials facing the cell suspension are

compatible with cultured cells. These materials include: stainless steel, Teflon, borosilicate glass or various ceramics (e.g., alumina). Glass and ceramics can be used to form the piezoelectric passive layer of the transducer and the mirror.

5 Brief Description of the Drawings

Figure 1 shows the cross-sectional schematic view of the composite resonator as multilayered one-dimensional structure and the course of the resulting acoustic particle velocity amplitude, if the layer dimensions are chosen according to the invention.

10 Figure 2 shows a version of Figure 1 with the transducer in between two suspension layers.

Figure 3 shows the schematic of a simple resonator example.

Figure 4 shows a composite resonator with a wave guide layer.

15 Figure 5 shows the cross section of a composite resonator using a totally reflecting mirror as resonator termination.

Figure 6 is a preferred symmetric version of the resonator according to Figure 5.

Figure 7 shows an example of a transducer layer according to one embodiment of the invention.

20 Figure 8 is a detailed drawing of one form of an apparatus according to one embodiment of the invention.

Figure 9 is a cross-sectional view showing an option of a composite mirror.

25 Figure 10 is a cross-sectional view of a two-dimensional sonication design.

Figure 11 shows a counter flow in the resonation chamber.

Figure 12 is a cross-sectional view of an alternative embodiment of a counter-flow resonation chamber.

30 Figure 13 is a cross-sectional view taken along lines 13-13 of Figure 8.

Detailed Description of the Invention

35 In order to simplify understanding of the basic features of the embodiments, the layers are labeled with alpha-characters, while all other parts are labeled with numbers.

The lower section of Figure 1 shows a schematic of the basics parts and dimensions of a typical piezoelectric composite one-dimensional resonator.

The transducer layer T on the left side preferably consists of an active piezoelectric layer A and a passive, electrically isolating, carrier layer B. The corresponding layer dimensions are x_T , x_A , and x_B , respectively. The transducer is acoustically coupled with the dispersion S; the dispersion layer dimension being x_S . Finally, the resonator is completed by the mirror layer M with thickness x_M . Since the composite resonator is surrounded by air with a specific acoustic impedance being some order of magnitudes lower than the acoustic impedance of any solid body, the ultimate terminating reflecting planes are the outside planes 11, 12 of the transducer layer and the mirror layer, respectively. Thus, the total length x_C of the composite structure is defined between these terminating planes. In the upper section of Figure 1 the spatial course of the acoustic particle velocity amplitude V along the longitudinal direction x is plotted. If the dimensions, the specific acoustic impedance of the layers as well as the electrical driving frequency f_e are chosen according to the invention, the maximum amplitudes in the dispersion are, as indicated, much higher than the maximum amplitudes in the other layers. Figure 1 shows this amplitude relationship only schematically. The quantitative ratio of the maximum amplitude of the standing resonance wave in the dispersion to the maximum amplitude in the transducer is usually higher than indicated in Figure 1.

The lower section of Figure 2 shows a schematic of the basic parts and dimensions of a typical one-dimensional piezoelectric composite resonator with the transducer T not only coupled to a first dispersion layer S with the dimension x_S on the right side, but also coupled to a second liquid layer S' with the dimension x'_S on the left side. The second liquid layer S' can either consist of the dispersion or of the dispersion medium (e.g., water) without suspended particles. The transducer layer T preferably consists of an active piezoelectric layer A and two passive, electrically isolating, carrier layers B and B' on both sides of the active layer A. The corresponding layer dimensions are x_T , x_A , x_B , and x'_B , respectively. The transducer is acoustically coupled with the dispersion layers S, S', respectively. Finally, the resonator is completed on each side by a first mirror layer M with thickness x_M on the right side, and by a second mirror layer M' with the thickness x'_M on the left side. Since the composite resonator is surrounded by air with a specific acoustic impedance being some orders of magnitude lower than the acoustic impedances of any solid body, the ultimately terminating reflecting planes are the outside planes 11, 12 of the mirror layers M', M, respectively. Thus, the total length x_C of the composite structure is

defined between these terminating planes 11, 12. In the upper section of Figure 2 the spatial course of the acoustic particle velocity amplitude V along the longitudinal direction x is plotted. If the dimensions, the specific acoustic impedance of the layers as well as the exciting frequency f_e are chosen according to the invention, the maximum particle velocity amplitudes in the dispersion layers are, as indicated, much higher than the maximum amplitudes in the other layers.

Figure 3 shows the schematic of a simple resonator. In this example, the piezoelectric layer is represented in y -direction by three piezoceramic plates or discs A1, A2, A3 of an equal thickness x_A , arranged side by side and provided with electrodes. The plates A1, A2, A3 are acoustically working parallel (in phase excited), while they are electrically connected in series. The plates A1, A2, A3 are bonded to a carrier plate B (e.g., glass or Al_2O_3 -ceramic) with thickness x_B and can be treated in good approximation as one continuous layer A with thickness x_A . The flow direction 6, 7 of the dispersion S is in direction y . The dispersed particles are driven by the acoustic radiation forces in longitudinal direction towards the antinode planes of the acoustic particle velocity, where the dispersed particles are agglomerated. The agglomerations are dragged by the gravity forces pointing downwards in direction y (enforced sedimentation by acoustically stimulated coagulation). The carrier plate B and the mirror plate M simultaneously perform as walls of the dispersion vessel. The rectangular cross-sectioned entrance 1 and exit 2 pipes are made tight to the carrier plate B and the mirror plate M via Viton®-rubber stripes 4 and 4', respectively. The distance ($x_B + x_S + x_M$) is precisely determined by the distance-rods 5 and 5' and the flanges 3, 3'. That is, the length of rods 5 and 5' and flanges 3 and 3' are selected to match or provide an exact desired dimension of x_C for the structure as shown in Figures 3, 4, and 8.

For some systems disclosed herein, flow is not discussed, and for some applications, flow may not be necessary; thus, designating a direction z does not signify a flow direction in all figures herein. For those systems for which a flow of the suspension liquid is discussed, this flow is defined as generally perpendicular to direction x and parallel to the direction z . Direction y is a depth of resonance chamber and is perpendicular to both directions x and z . For Figure 3, the flow direction z is horizontal to gravity, with gravity acting in direction y .

For example, the preferred dimensioning of two resonators according to the invention is as follows:

For biological cells with diameters of the order of 10 μm the appropriate driving frequency f_e is according to equation (I) typically around 2 MHz. As standard piezoceramic plates are chosen:

5 Piezoelectrically active layer A:

Material: PZT Lead-Zirconate-Titanate, $\text{Pb}(\text{Ti,Zr})\text{O}_3$ piezoceramic Hoechst Sonox P4

Mass Density: $\rho_A = 7800 \text{ kg/m}^3$

Effective sound velocity for shortened electrodes: $v_A = 3950 \text{ m/s}$

10 Specific acoustic impedance: $Z_A = 30.8 \cdot 10^6 \text{ kg/m}^2\text{s}$

Thickness: $x_A = 1 \text{ mm}$

The fundamental series resonance frequency for layer A can be determined from equation (III): $f_A = 1.97 \text{ MHz}$. The series resonance frequency is relevant, because the driving electronics G is assumed to be of the usual low source impedance type. Six (2 x 3) square plates with 25 mm x 25 mm face dimensions are bonded upon a passive layer B (compare also Figure 7), the thickness value x_B of this passive layer is chosen equal to a standard glass thickness:

20

Piezoelectrically passive layer B:

Material: Tempax glass

Mass density: $\rho_B = 2200 \text{ kg/m}^3$

25 Sound velocity: $v_B = 5430 \text{ m/s}$

Spec. ac. impedance: $Z_B = 12 \cdot 10^6 \text{ kg/m}^2\text{s}$

Thickness: $x_B = 2.8 \text{ mm}$

30 The resonance frequencies of the two-layer transducer surrounded by environmental air can be measured or calculated (E. Benes, J. Appl. Phys., Vol 56, No. 3, 1 August 1984). The first four quasi-harmonic frequencies are:

$$f_{T1} = 573500 \text{ Hz,}$$

35 $f_{T2} = 1371400 \text{ Hz,}$

$$f_{T3} = 1958120 \text{ Hz,}$$

$$f_{T4} = 2546390 \text{ Hz.}$$

According to equation (XII) the advantageous intervals for the driving frequency
5 f_e are:

$$0 \text{ Hz} < f_e < 516150 \text{ Hz} ; 630850 \text{ Hz} < f_e < 1302830 \text{ Hz} ; 1439970 \text{ Hz} < f_e < 1892849 \text{ Hz} ; 2023391 \text{ Hz} < f_e < 2482730 \text{ Hz} ; \dots$$

10 The dispersion layer dimension x_S depends for instance on the flow rate required and is chosen to be 25 mm:

Dispersion layer S:

15	Material:	Hydrosol
	Mass density:	$\rho_S = 1000 \text{ kg/m}^3$
	Sound velocity:	$v_S = 1500 \text{ m/s}$
	Spec. ac. impedance:	$Z_S = 1.5 \cdot 10^6 \text{ kg/m}^2\text{s}$
	Thickness:	$x_S = 25 \text{ mm}$

20

Mirror layer M:

	Material:	Tempax glass
	Mass density:	$\rho_M = 2200 \text{ kg/m}^3$
25	Sound velocity:	$v_M = 5430 \text{ m/s}$
	Spec. ac. impedance:	$Z_M = 12 \cdot 10^6 \text{ kg/m}^2\text{s}$
	Thickness:	$x_M = 1.3 \text{ mm}$

30 These parameters result in resonance frequencies f_{Cj} of the composite resonator with a distance Δf_{Cj} of approximately 26 kHz. Therefore, there are many composite resonance frequencies falling into the advantageous intervals. For example, the first resonance frequency f_{Cj} in the fourth interval is 2035555 Hz, the second 2061024 Hz, the third 2087140 Hz; thus, the exciting frequency f_e can be chosen for instance to be equal to 2087140 Hz. Since the
35 fundamental Eigen-frequency of the mirror is 2088460 Hz, the selected driving frequency is not sufficiently mismatched to the mirror resonances, as a consequence, the mirror thickness has to be changed, e.g., to 1.8 mm.

A design which is optimal with respect to the object of the invention uses, except the passive layer B, the same layers. The passive layer B is made of a thickness x_B that produces a node of the particle velocity amplitude V at the interface transducer/dispersion. If the driving frequency f_e is selected to be about the Eigen-frequency f_A of the active layer A, which guarantees optimal excitation of the composite resonator, the phase shift φ_A in the active layer A is equal to π . Since there is an antinode boundary condition at the interface plane 11 between active layer A and surrounding air, and since the phase shift φ_A in the active layer A is equal to π , the phase shift φ_B in the passive layer B must be chosen to be equal to $\pi/2$ or equal to an odd multiple of $\pi/2$ to obtain a node of the particle velocity V at the interface plane between transducer T and dispersion S. Introducing this phase shift $\pi/2$ in equation (II) yields

$$\varphi_B = 2\pi \cdot f_e \cdot x_B / v_B = \pi/2$$

and allows the calculation of x_B . If for a more rugged application the result of $x_B = 1.2$ mm is mechanically too weak, three times the value can also be used.

Piezoelectrically passive layer B:

Material:	Alumina (Al_2O_3) ceramic
Mass density:	$\rho_B = 3780 \text{ kg/m}^3$
Sound velocity:	$v_B = 9650 \text{ m/s}$
Specific acoustic impedance:	$Z_B = 36.5 \cdot 10^6 \text{ kg/m}^2\text{s}$
Thickness:	$x_B = 1.2 \text{ mm}$

The first two Eigen-frequencies of this transducer are $f_{T1} = 1335150$ Hz, $f_{T2} = 2866080$ Hz. According to equation (III) the intended driving frequency $f_e = 1.97$ MHz is now approximately in the middle of the advantageous interval: $1468665 \text{ Hz} < f_e < 2722776 \text{ Hz}$.

In this example the optimum thickness for the mirror is determined from (II):

$$\varphi_M = 2\pi \cdot x \cdot f_e / v_M = \pi/2;$$

$x = 0.692$ mm. Since this value is rather too small for a reasonable mechanical ruggedness, three times this value is chosen $x_M = 2.07$ mm.

Similar to the composite transducer T, the mirror M may also consist of an active A and a passive B layer with the same criteria for choosing the thicknesses x_A and x_B of such layers, respectively. The active layer of the mirror provides an electric signal, which can be used to automatically control the exciting frequency f_e towards a preferred composite resonance frequency f_{Cj} .

Figure 4 shows an extension of the composite resonator according to Figure 3. In this example, an additional wave guide layer W, filled with a low loss liquid (e.g., distilled water), separated by an acoustically transparent wall F from the dispersion S, is inserted. The dimension x_F of the wall F is, with respect to the excitation frequency f_e , either small compared to a quarter of the wavelength or equal to half-wavelength or a multiple of the half-wavelength in that wall material, or the specific acoustic impedance of the wall material is approximately the same as the specific acoustic impedance of the dispersion. In the first case, e.g., Saran® or Mylar® foils with a thickness of 10 μm are used as wall F. In the second case, the wall F can be made virtually of any material, but for a material with a specific acoustic impedance close to the specific acoustic impedance of the dispersion S, the dimension of the layer F is less critical. Using the phase-nomenclature, the acoustically transparent layer F produces a phase shift ϕ_F of an integer multiple of π . In the third case, a proper material is, e.g., TPX (Methylpestene) or ABS (Acrylonitrile Butadiene Styrene). The additional wave guide layer W serves as a high quality factor resonator part, which removes the very inhomogeneous near field region of the transducer T from the separation zone S, thus significantly reducing the potential for acoustic streaming in the dispersion S. This resonator design version allows also an enhanced cooling and a temperature control of the system by circulating a liquid between the wave guide layer W and a thermostat. In this case the side walls 8 and 8' can be equipped with an entrance and exit pipe, respectively. This resonator design version also proves the applicability of this invention to the so called drifting resonance field (DRF) concept described in a recent patent application (U.S. Appl. No. 474,813 and PCT Appl. No. PCT/AT89/00098). This PCT application has been published and is incorporated herein by reference. In the case of the DRF separation procedure, the composite resonator is not only driven at one certain harmonic resonance frequency, but is rather switched repeatedly from one frequency to another. For example, the frequency is selected from a group of frequencies, e.g., five to twelve, adjacent, closely spaced resonance quasi-harmonic frequencies f_{Cj} . Particles dispersed in the dispersion S are moved in a stepwise manner as a result of movements of the

antinode planes in longitudinal direction x when the frequency changes from one frequency to the next frequency. This allows the splitting of the dispersion exit pipe 2 into two parts, one 7 for the clarified dispersion medium, the other 7' for the dispersion medium highly enriched in dispersed particles. To minimize
5 acoustically induced dissipation, the exciting frequencies of the DRF procedure have to be tuned towards resonance frequencies in the neighborhood of preferred resonance frequencies f_C ; according to the invention.

Figure 5 shows the cross section of a composite resonator using a totally reflecting retro-reflector R as mirror terminating the composite resonator.
10 Said retro-reflector R is preferably formed by two plates at right angle to each other. The orientation of the flow of the dispersion S is preferably chosen opposite to the orientation of the force of gravity and coincides in Figure 5 with the z -axis. This resonator version is especially advantageous, since there are no side walls engaged which have to be ignored or neglected with respect to their
15 acoustic influence in order to allow a one-dimensional treatment. In contrast to that, a well defined one-dimensional behavior of resonators according to Figure 3 and Figure 4 can often only be obtained, if the lateral dimensions of the layers are much higher than the longitudinal ones, which is sometimes not desirable.

The acoustic material parameters of the retro-reflector R must be of
20 a value so that the total reflection condition at the interface between dispersion S and reflector R is fulfilled for the tilt-angle α of the reflector being equal to 45° . Total reflection at the interface-planes 12', 12" between dispersion and retro-reflector disables any acoustically induced dissipation in the reflector R. If the medium of the reflector R is chosen isotropic having a value of the sound speed
25 for shear waves equal to or higher than 1.41 times the sound speed for longitudinal waves in the dispersion S, the limit angle for the total reflection condition at the interface between dispersion S and reflector R is exceeded for the tilt-angle α of the reflector being equal to 45° . (In the case the reflector R is made from an anisotropic medium, the lower of the two possible shear-wave
30 sound speeds must be equal to or higher than 1.41 times the sound speed for longitudinal waves in the dispersion S.) That is, the excited sound waves are, for the case of neglected losses within the media, totally reflected already at the interface-planes 12', 12" between dispersion and reflector. This condition is fulfilled, e.g., for an aqueous dispersion and the reflector wall materials
35 Molybdenum, stainless steel and even for the wall material Aluminum. Although the actual sound paths along the distances x_{S12} and x_{S22} are now

falling parallel to the y-axis, the total length of any sound path in the dispersion is equal:

$$(x_{S11} + x_{S12} + x_{S13}) = (x_{S21} + x_{S22} + x_{S23}) = 2x_S.$$

5

Thus, a virtual total reflection plane 12 of an equivalent one-dimensional resonator can be defined, whereby the effective layer thickness x_S of the dispersion S is constant versus lateral directions y and z and all layer dimensions again can be chosen according to the invention.

10

Figure 6 is a preferred symmetric version of the resonator shown in Figure 5. The main advantage of this design is the use of a square cross section tube, whereby the tube walls simultaneously perform as walls for the dispersion and as totally reflecting means for the composite resonator. Each of the thicknesses x_B , $x_{B'}$ of the two passive layers B, B', as well as the thickness x_A of the active layer A, are chosen according to the invention.

15

Figure 7 shows a more detailed drawing of a composite transducer. The same drawing applies for an active mirror, which includes a piezoelectric layer A according to the invention. In the example shown in Figure 7, the piezoelectrically active layer A is represented by six piezoelectric plates A1, A2, 20 A3, A4, A5, A6, which are of equal thickness x_A , arranged side by side and provided with electrodes. The plates are acoustically working parallel (excited in phase), while they are electrically connected in series to match the electrical impedance of the transducer to the output of the frequency generator G. Said generator G provides via the clamps E1, E2, the electrical excitation signal with a frequency f_e . U_e and I_e are the amplitudes of the driving voltage and current, 25 respectively. The plates are bonded upon an electrically insulating and piezoelectrically passive carrier plate B of a thickness x_B , such as glass or Al_2O_3 -ceramic, and can be treated in good approximation as one continuous layer with a thickness x_A . The electrical connections between the piezoelectric plates are provided by copper films I1, I2, I3, I4, and by electrode layers J1, J2, 30 J3, of a thickness x_E , which causes a phase shift φ_E of less than $1/16$ of the number π . Said electrodes are deposited onto the surface of the passive carrier layer B next to the active layer A. The thicknesses x_A and x_B have defined values according to the invention in order to achieve low acoustically induced thermal dissipation. Best results can be achieved if the specific acoustic 35 impedance Z_B of the passive layer is close to or higher than the specific acoustic impedance of the piezoelectrically active layer Z_A . The thickness x_A of the

active layer is preferably close to or equal to a value, which causes a phase shift ϕ_A being an odd multiple m of the number π , the thickness x_B of the passive layer B is preferably close to or equal to a value, which causes a phase shift ϕ_B being an odd multiple n of half of the number π . An odd multiple q of passive sublayers B1, B2, B3, (or more) each of a thickness $x_{B,k}$ ($k = 1 \dots q$) causing a phase shift $\phi_{B,k}$ as described above for a single passive layer B is also useful to lower energy dissipation. Said odd multiple of passive layers Bk are of alternating high ($Z_{B,k} \geq Z_A$, $k \dots \text{odd}$) and low ($Z_{B,k} < Z_A$, $k \dots \text{even}$) specific acoustic impedance, but starting and ending with high ones in the range of Z_A of the active layer A. In a variation of this arrangement of passive sublayers Bk, low-impedance sublayers may also be a fluid.

Figures 8-13 illustrate in more detail some of the features that are more particularly claimed in the related application filed concurrently herewith bearing U.S. Serial No. _____, filed on July 2, 1993 and naming Felix Trampler, James M. Piret, Stefan A. Sonderhoff and Douglas G. Kilburn as inventors. To facilitate a more complete understanding of additional possible uses of the invention in this application, some features of the embodiments claimed in that application will now be described.

Figure 8 shows a design for performing the method according to one embodiment of the invention. One possible application for the embodiment described is the separation of medium (containing a desired product) from mammalian cells, which are grown within said medium in a bioreactor 21. A composite transducer layer T, a mirror layer M and a suspension layer S form a multilayered composite resonator with a total length x_C . The composite transducer T consists of one or several solid, piezoelectrically active plates with electrodes A_1, A_2 (or more), of a thickness x_A (together referred to as active layer), and of a dielectric, solid, piezoelectrically passive layer B of a thickness x_B . The piezoelectric plates A_1, A_2 (or more), e.g., PZT (Lead-Zirconate-Titanate) ceramics, are bonded onto the passive layer B which has a specific acoustic impedance Z_B close to the specific acoustic impedance Z_A of the active layer. At the interface of said layers, the passive layer B is coated with thin connecting electrode layers of a thickness x_e , which causes a phase shift ϕ_e of less than $1/16$ of the number π (not shown). Mirror M and passive layer B also form walls of the vessel containing the suspension S.

The transducer T is excited by an electric signal of a frequency f_e from power supplies 31 and 32. The operation and timing of power supplies 31 and 32 is controlled by a controller 33. Using two independent power supplies

for exciting the active plates A1 and A2 is an option; alternatively, A1 and A2 are driven by a single power source as shown in Figure 7. The frequency f_e is within the half-value of a longitudinal high-overtone resonance frequency f_C of the composite resonator, whereby, according to the invention, f_C is not in the range of any of the resonance frequencies f_T of the transducer or f_M of the mirror alone. Therefore, the thickness of the transducer $x_T = x_A + x_B$ is close to, or equal to, a value, which causes a phase shift φ_T being an odd multiple of the number $\pi/2$. Also, the thickness of the mirror x_M is close to, or equal to, a value, which causes a phase shift φ_M being an odd multiple of the number $\pi/2$. The specific acoustic impedance Z_M of the mirror is high compared to the specific acoustic impedance Z_S of the suspension.

The resonator is mounted onto the head plate 21 of the bioreactor 22 in vertical position z . According to the present invention, the flow direction 25 of the suspension is transversal to the direction of sound propagation x and is oriented against gravity g , which results in a considerable increase in retention time of suspended particles compared to retention time of the fluid within the resonator. The flow rate is chosen to be higher than the value correlated to a thermally induced increase of spatial phase shift $\Delta\varphi_S$ of the acoustic wave of one quarter of π within the suspension. In addition the temperature of the outer surface of the transducer T, the side walls of the vessel and the mirror M can be controlled by circulating air or a dielectric liquid through the pipes 29', 29".

The diameter of the inflow tube 23 is approximately equal to the dimension x_S of the square-shaped (x,y) cross section of the suspension layer S. The aggregates tend to stick to any protruding surfaces. Therefore, the inflow tube 23, being also the setting tube, should be free from protrusions or ledges to which the aggregates may stick and be of a large diameter, preferably approximately equal to or greater than the diameter of the resonation chamber. The big diameter of the inflow tube 3 provides a sufficiently low inflow velocity to allow settling 26 of aggregated particles against flow direction 25. For one embodiment, at least two sets of baffles 28', 28" (or more), decrease turbulence or thermally induced streaming inside the inflow tube 23. The (x,y) cross section of each set is a grid with a grid frequency between 1.5 to 5 cm^{-1} to avoid break up settling aggregates as shown in Figure 13. The length of one set (along z) typically ranges from 1 to 5 cm, the spacing between two adjacent sets of baffles 28' and 28" is preferably of the same range. If required, a single pass shell and tube heat exchanger (not shown) could replace one set of baffles to precool fluid before entering the resonator. Laminar flow is aided by a cone-shaped outflow

port 24, which possibly includes baffles, too (not shown). The pump 27 is placed after the outlet to prevent mechanical damages to recycled cells. Fresh medium is added through pipe 210 to the bioreactor to compensate for harvested medium and allow continuous harvesting. Materials facing the suspension are biocompatible to cell culture, e.g., stainless steel 316, Teflon, borosilicate glass or various ceramics.

Figure 9 shows the square-shaped (x,y) cross section of the composite resonance chamber 29 of Figure 8 in which the option of a composite mirror M, is shown. Such a composite mirror consists of a piezoelectrically active layer A', with a thickness $x_{A'}$, and a piezoelectrically passive layer B', with a thickness $x_{B'}$, similar to the active layer A and passive layer B of the transducer T. The length of the composite mirror given by $x_M = x_{A'} + x_{B'}$ is close to, or equal to, a value, which causes a phase shift ϕ_M being an odd multiple of the number $\pi/2$. The active layer of the mirror provides an electric signal, which can be utilized for automatically tuning the exciting frequency f_e toward a preferred composite resonance frequency f_C according to the invention.

Figure 10 is a (x,y) cross-sectional view of an alternative design that uses a two-dimensional composite resonance chamber 29 design, whereby the geometry of the one-dimensional multilayered composite resonance 29 is repeated to a second dimension perpendicular to the first one and to flow direction z. The composite resonator in direction x consists of the piezoelectrically active layer $A(x)$ and passive layer $B(x)$ of the transducer $T(x)$, the suspension S, and mirror $M(x)$, whereby the composite resonator in direction y consists of the piezoelectrically active layer $A(y)$ and passive layer $B(y)$ of the transducer $T(y)$, the suspension S, and mirror $M(y)$. All thickness dimensions are chosen according to the invention, as explained herein.

Figures 11 and 12 show a variation of Figure 8 to compensate for the effect of the spatial temperature gradient versus flow direction. An acoustically transparent layer, referred to as film layer F, divides the suspension layer into a down-flow section S' and an up-flow section S'' in transversal orientations z, -z, respectively, perpendicular to the direction of sound propagation x. The acoustic impedance Z_F of said layer F is close or equal to the caustic impedance Z_S of the suspension S', S''. The thickness x_F of the layer F can be either small compared to the dimension of a quarter of the wavelength or close to, or equal to, the half-wavelength in that film layer material for the exciting frequency f_e of the power generator driving the transducer. The suspension enters the entrance port 24' of the resonator and passes through the

section S' of the chamber next to the transducer T. An outflow pump 27" at the exit port 24" operating at a slightly slower flow rate than the inflow pump 27' at the entrance port 24' results in a low net downward flow within the settling tube 23. Most of the partially clarified media enter and pass through the second section S" of the resonance chamber close to the mirror M, while acoustically aggregated particles settle down 26 the settling tube 23 at the base of the chamber, facilitated by the net downward flow. The counter flow of media on either side of the acoustically transparent layer F results in a uniform average temperature across the entire length of the composite resonator. This compensates for spatial temperature gradients caused by acoustically induced dissipation and allows a uniform resonant field to be maintained despite thermal gradients on either side of the membrane. The higher flow rate next to the transducer T should offset the additional electrically induced thermal dissipation from the transducers as well as higher acoustically induced thermal dissipation within the more concentrated particulate suspension in the down-flow section S' compared to the up-flow section S". The operation of this device can be modified in the following way: the inflow pump 27' can be eliminated and provision made to block the recycle tube 23 at the base of the chamber. The recycling system can then be operated in a semicontinuous fashion with periodic opening of the recycle tube accompanied with back flushing the accumulated particles to a recycling vessel.

Figure 12 illustrates an alternative embodiment in which two layers F, perpendicular to each other, are used. In the embodiment of Figure 11, only a single layer F is present, separating the suspension layer into two sections. In the alternative embodiment, the separation layer is segregated into four sections as shown in Figure 12. According to the modification of Figure 12, a two-dimensional field as introduced in Figure 10 is used. In that case, two acoustic transparent layers $F(x)$ and $F(y)$ in perpendicular position to each other are required, dividing the vessel into two up-flow and two down-flow sections. Generally, the suspension layer can be split up in any number of suspension layers parallel to transducer and mirror, as long as counter flow of suspension is provided in adjacent suspension layers.

Figure 13 is an illustration of the baffle grid 8 as shown in Figures 8 and 11. Specifically, the baffle grid has a plurality of walls extending completely across the inlet tube 23. The grid spacing can be in the range of 1.5 - 5 grids per cm depending upon the size of the inlet tube 23. While a circular inlet tube 23 is shown, the tube could also be rectangular or square.

The operation of the invention according to the embodiments shown in Figures 8-13 are as follows. A culture of cells, preferably mammalian cells, are grown in a stirred tank bioreactor chamber 22. The chamber 22 is stirred chamber using prior art techniques for mixing to ensure that aggregates are properly separated inside the chamber 22, itself. It is desirable to retain viable cells within the bioreactor chamber 22. In biotechnology, these cells can be used to produce proteins or other secreted products of pharmaceutical importance. The products of such cells are secreted into the liquid medium within the bioreactor chamber 22. It is desirable to keep as many viable cells within the bioreactor chamber 22 while at the same time removing the useful byproducts, such as proteins or other secretions which have been produced by the viable cells. Therefore, according to principles of the present invention, the acoustic resonation chamber 39 is positioned above the bioreaction chamber 22 to filter the viable cells. An inflow tube 23 is inserted into the bioreaction chamber and immersed in the liquid in which the cells are cultured and in which the desired byproduct is located. A pump 27 on the down stream side of the acoustic resonation chamber 39 draws liquid medium, containing viable cells and the byproducts of such cells, into the inlet tube 23 and into the acoustic resonation chamber 39. In one embodiment, baffles 28', comprising baffles 28' and 28'' are provided within the inlet 23.

As the fluid is drawn through the acoustic resonation chamber 39, one or more transducers T emit acoustic waves into the bioreaction chamber 39. As previously discussed in detail herein, a standing wave is created of a desired frequency that traps the viable cells in the acoustic reaction chamber. The acoustic waves act as a filter to prevent viable cells from exiting at the outlet 24. As the viable cells collect at the nodes of the standing waves, they begin to aggregate. The maximum acoustic particle velocity amplitude within the suspension is maintained at a value that will not result in damage to the viable cells. The preferred frequency f_C of the composite resonator is in the range of 2 to 4 MHz and is selected based on principles previously described.

As the viable cells aggregate, they begin to form clusters within the antinode planes. When the clusters reach a sufficient size, the clusters settle out via the force of gravity and fall against the direction of the fluid flow generated by pump 27. That is, the clusters of cells descend through the baffles 28' and 28'' and back into the mixture where they are broken up in the stirred reactor chamber 22 and continue to secrete the desired byproducts. The liquid which exits from the outlet 24 is substantially free of viable cells and yet contains the

desired protein and other byproducts which have been produced by the viable cells. The liquid is placed in a separate container and the desired byproducts are removed using techniques well known in the art.

Nutrients and liquid to replace the liquid which has been removed
5 are placed into the bioreactor chamber 22 via inlet tube 210. The present invention thus provides a technique for continuously removing liquid containing byproducts while ensuring that viable cells are filtered from the liquid using a technique which does not damage the viable cells. The viable cells are retained and cultured in the bioreactor chamber 22 for continued production of the
10 byproducts.

As previously discussed and shown in Figure 8, according to an alternative embodiment of the present invention, the transducer T is composed of two separate active layers A1 and A2. These regarded segments are simply referred to as transducers A1 and A2. The transducer A1 is driven by a first
15 power supply 31 and the transducer A2 is driven by a second power supply 32. In one embodiment, the f_{e1} and f_{e2} are of the same frequency. Alternatively, different frequencies can be used if desired. The controller 33 controls the timing and operation of the power supplies 31 and 32 providing power to the transducers A1 and A2.

20 According to one mode of operation, the controller 33 controls the power supplies 31 and 32 to operate them simultaneously for the creation of one or more acoustic standing waves which filter out viable cells and permits them to collect for return to the bioreaction chamber 22. According to an alternative mode of operation, the power supplies 31 and 32 are operated simultaneously for
25 a selected period of time. Then, after a certain time of operation, the controller 33 reduces or completely cuts off power to one of the power supplies, either power supply 31 or 32. The other power supply remains in standard operating mode. When one of the power supplies has the power reduced or removed, the standing wave created by the respective transducer A1, or alternatively A2, is
30 significantly reduced or removed. The removal of the acoustic wave generated by one of the transducers has been found advantageous to permit cells which are collecting in clusters within the antinode planes to be released and descend under the force of gravity, until they have descended back into the bioreaction reactor 22. After one of the power supplies is off for a selected period of time, then the
35 power supply is returned to operation at the standard power and the acoustic wave again begins to act as a filter. Then, a short time later, the other power

supply significantly reduces or discontinues the power provided to its respective transducer, and the pattern continues.

For example, at the beginning of the operation, both power supplies 31 and 32 may be operating. After a selected period of time, power supply 32 may be turned off and the acoustic waves transmitted by transducer A2 will cease. Power supply 31 remains on at the standard power and the acoustic waves generated by transducer A1 remain within the resonation chamber 39. Cells which have been aggregating in the nodes from the transducer A2 will therefore be released. Those which are heavy enough can now descend back into the bioreactor 22. Any groups of cells which do not descend will be blocked by the acoustic wave generated by transducer A1. After a selected time period, power supply 32 is turned back on and transducer A2 again generates a standing wave. Then, after another selected time, power supply 31 is turned off and the standing wave generated by transistor A1 is removed. The cells which have been collecting at the antinodes of the standing wave created by transducer A1 now begin to descend and return to the medium in reactor 22. After a selected period of time, power supply 31 once again provides power to transducer A1. This pattern may be repeated. Preferably, the transducers A1 and A2 are positioned spaced from each other along the directional flow of the liquid so that the liquid sequentially passes transducer A2 and then passes transducer A1. The controller 33 controls the timing and operation of power supplies 31 and 32 so that the transducers may be operated simultaneously or turned off in alternation. Alternating the turning off of the power to the transducers arranged in this sequence has been found to be a more effective technique for filtering mammalian cells from the moving liquid than certain prior art techniques. Of course, more than two transducers in series can be used and this mode of operation can be used for the horizontal flow of Figures 1 and 2. Alternatively, a single transducer or the composite transducer of Figure 7 can be used.

When power is applied to the transducer, a portion of the energy is converted into heat. Preferably, the heating up of the transducer itself is minimized by circulation of a cooling period through inlet and outlet pipes 29' and 29". As explained in detail herein, the temperature of the liquid directly affects the phase shift of the acoustic waves traveling through such liquid. It is desired to maintain the temperature change of the liquid below a selected level as it passes through the resonation chamber 39. One technique for ensuring that the temperature change within the resonant chamber 39 is kept at a low level is to maintain a relatively high flow rate of the liquid through the resonation chamber.

The liquid is thus only within the resonance chamber for a brief period of time and quickly passes out of the outlet port 24. If the liquid flow rate is too high a flow rate, the acoustic waves may not be able to filter as high a percentage of the viable cells from the liquid as would be desired. The flow rate can therefore be
5 reduced to increase the filtering of the viable cells. According to principles of the present invention, if the flow rate is reduced below a certain level, it will be so low that the temperature of the liquid becomes elevated, creating an undesirable phase shift change between the standing wave at the inlet of the resonance chamber and the standing wave at the outlet of the resonance
10 chamber. Preferably, the flow rate is selected such that the phase shift change between the resonance inlet port and the outlet port of the resonance chamber 39 is less than $\pi/2$. In the example given herein, the preferred phase shift change is in the range of or slightly less than $\pi/4$. This corresponds to a temperature change of approximately 2° Kelvin from the inlet of the standing wave to the
15 outlet of the standing wave. There is thus a non-homogeneous temperature distribution between the inlet and the outlet, that is, there is a different temperature at the inlet than at the outlet with a temperature gradient therebetween. The non-homogeneous temperature distribution is acceptable so long as the temperature change does not exceed a value that will cause the phase
20 shift to be greater than half π and the preferred embodiment will not cause the phase shift to be greater than approximately one quarter of π .

One specific example follows but those of ordinary skill in the art will easily recognize that the principles of this invention may be applied to numerous different systems of different sizes to achieve a good filtering of the
25 viable cells from the liquid medium passing through the resonance chamber 39.

Example

An apparatus according to the invention as shown in Figure 8 was used as an acoustic filter to separate mammalian cells from medium and to
30 recycle the aggregated cells back to a bioreactor. The hybridoma 2E11 cell line used was grown in Dulbecco's Modified Eagle Medium (DMEM) with 5% newborn calf serum.

Dimensions:

35 The thickness x_A of the piezoelectrically active layer (Lead-Zirconate-Titanate ceramic) of the transducer was 1 mm, the thickness x_B of the passive layer (borosilicate glass) 3.3 mm. Eigen-frequencies f_T of this

composite transducer in air were measured at 2.25 MHz ($\varphi_T = 4\pi$) and 2.8 MHz ($\varphi_T = 5\pi$).

A thickness $x_M = 2.7$ mm of the mirror layer (borosilicate glass) has been chosen according to the invention. Eigen-frequencies f_M of this single-layered mirror have been calculated from equation (V) and resulted in 2 MHz ($\varphi_M = 2\pi$) and 3 MHz ($\varphi_M = 3\pi$).

The transducer-mirror distance was 25 mm.

These Dimensions resulted in a spectrum of resonance frequencies f_C of the composite resonator with a distance Δf_C of approximately 28 kHz. According to the invention, the exciting frequency f_e was tuned towards a resonance frequency f_C of the composite resonator at about 2.4 to 2.5 MHz in order to avoid excitation of Eigen-frequencies of the transducer or mirror. As a result, the thickness of the transducer corresponded to a phase shift φ_T of the acoustic wave inside the transducer close to nine times the number $\pi/2$; the total thickness of the mirror corresponded to a phase shift of the acoustic wave inside the transducer close to five times the number $\pi/2$. The average active power consumption $\langle P_{e1} \rangle$ was about 3.5 W, the resonator volume was 35 mL. The total length of the flow path within the resonance field was 5.2 cm; the inflow cell concentration was about $5 \cdot 10^6$ cells/mL at a viability of about 91%.

Depending on the flow velocity v , the typical separation efficiencies e_v for viable cells and e_{nv} for non-viable cells have been monitored:

v [cm/min]	e_v [%]	e_{nv}	ΔT [K]	$\Delta\varphi_S$
0.9 cm/min	92%	84%	3.5K	$0.45 \cdot \pi$
1.3 cm/min	95%	83%	3.0K	$0.39 \cdot \pi$
1.8 cm/min	98%	80%	2.0K	$0.26 \cdot \pi$
2.5 cm/min	96%	86%	1.7K	$0.22 \cdot \pi$
3.6 cm/min	95%	87%	1.4K	$0.18 \cdot \pi$
5.2 cm/min	94%	89%	1.0K	$0.13 \cdot \pi$
7.3 cm/min	92%	89%	-	-

The increase of phase shift $\Delta\varphi_S$ along flow path within the suspension is calculated from the measured temperature difference ΔT between inflow and outflow temperature according to equation (IX). According to the invention, no increase of separation efficiency e_v for viable cells has been achieved at flow velocities correlated to an increase of phase shift $\Delta\varphi_S$ of more

than approximately one quarter of π . Also, a significant difference between the separation efficiencies e_v for viable cells and e_{nv} for non-viable cells have been observed. Generally, typical inflow cell concentrations range from 0.1 to above 25 million cells/mL.

5 Reviewing the table which contains the examples, it can be seen that the maximum separation efficiency e_v is found for a flow rate in the range of 1.3 - 2.5 cm per minute. For example, at a flow rate of approximately 1.8 cm per minute, the filter has a separation efficiency of 98 percent for viable cells. For nonviable cells, the separation efficiency is 80 percent and thus permits a larger
10 percentage of the nonviable cells to escape, which is preferred. The temperature change from the inlet of the resonation condition to the outlet of the resonation condition is approximately 2° Kelvin. This results in a phase shift change $\Delta\phi_S$ of approximately $\pi/4$, as shown on the chart as being exactly $.26\pi$. Slightly higher flow rates, for example, 2 cm per minute to 2.5 cm per minute, are also
15 acceptable for providing high filtering efficiencies of viable cells while permitting a non-homogeneous distribution of the spatial phase shift ϕ_S of the acoustic wave within the suspension in the resonator 39. In other embodiments, using differently sized elements, flow rates in the range of or exceeding 8-10 cm/m are used. For different sized elements, the specific flow rates may vary.

20 Alternative parameters for the geometry of a multilayered resonator according to the invention are, for example:

The thickness x_A of the piezoelectrically active layer (Lead-Zirconate-Titanate ceramic) of the transducer is 1 mm, the thickness of x_B of the passive layer (Alumina (Al_2O_3)-ceramic) 3 mm. This example is especially
25 advantageous, since the specific acoustic impedance Z_B of Alumina-ceramic is higher than the specific acoustic impedance of the piezoelectric active layer Z_A . Eigen-frequencies f_T of this composite transducer in air can be measured at 1.8 MHz ($\phi_T = 2\pi$) and 2.7 MHz ($\phi_T = 3\pi$). Therefore, according to the invention, the exciting frequency f_e has to be chosen within the half-value bandwidth of a
30 resonance frequency f_C of the composite resonator around 2.25 MHz. To optimize mismatching between this exciting frequency f_e and any of the Eigen-frequencies of the mirror according to equation (V), the thickness x_M of the mirror layer (borosilicate glass) has to be chosen at 0.6 mm or any of its odd multiple.

35 To summarize the basic features of one embodiment of the present invention, an apparatus for separating suspended particles from a liquid by means of applying a resonant ultrasonic sound field in a multilayered composite

resonator has been described. Preferably, the composite resonator includes acoustically coupled, parallel layers formed in the longitudinal propagation direction x of the acoustic wave including at least a piezoelectric transducer and an acoustic mirror with the suspension liquid in between them from which the particles are to be filtered. The transducer layer is excited by an electrical power generator with a high frequency (f_e) within the range of the half-value bandwidth of a characteristic high overtone resonance frequency (f_C) of the multilayered composite resonator 39. Preferably, the thickness (x_T) of the transducer is of a value which causes a spatial phase shift ϕ_T of the acoustic particle velocity amplitude at the generating frequency (f_e) such that the phase shift is close to or equal to an odd multiple of $\pi/2$. The flow velocity of the suspension liquid in the resonance chamber 39 is of a value that results in a temperature distribution (T_z) in a direction z , averaged across the resonance chamber in direction x , such that the temperature distribution (T_z) causes a non-homogeneous distribution (ϕ_{sz}) of spatial phase shift of the acoustic wave within the suspension liquid having a total range ($\Delta\phi_s$) of less than one quarter of π . In some embodiments, a total phase shift range in the range from 0 to $\pi/2$ is permissible, however, preferably the phase shift change is in the range of approximately $\pi/4$ or lower.

According to one embodiment, the transducer is comprised of a piezoelectric solid layer with electrodes, referred to as the active layer, and a non-piezoelectric solid layer, referred to as the passive layer whereby the passive layer is made of a dielectric material with a specific acoustic impedance (z_B) close to, or higher than the specific acoustic impedance (z_A) of the active layer. Alternatively, any other transducer or transducer layer of the type used in the prior art may be used.

In addition, a mirror is provided on the opposite side of the resonance chamber 39 that is made of a material with a specific acoustic impedance (z_M) high compared to the specific acoustic impedance (z_S) of the suspension liquid and the thickness (x_M) of the mirror is selected to be of a value which causes a spatial phase shift (ϕ_M) of the acoustic particle velocity amplitude that is close to, or equal to, an odd multiple of the number $\pi/2$.

Preferably, the flow orientation z of the suspension liquid is oriented against the force of gravity acting in orientation minus z .

According to an alternative embodiment, the piezoelectrically active layer of the transducer is formed by at least two adjacent piezoelectric plates, each plate being bonded onto a single passive layer. Each regarded transducer segment is excited by an individual electrical power generator 31 and

32, and, thus, individual resonant standing waves within the composite resonator 39 are created. The individual periods of excitation are possibly interrupted by individual periods of no excitation resulting in settling periods of the aggregates of cells within the regarded part of the suspension liquid.

5 In one alternative embodiment, at least one of the individual standing waves is in a direction x and another wave is superimposed by an additional transducer creating an additional resonant standing wave in direction y perpendicular to x , the additional standing wave created by an additional transducer and mirror, which are parallel to each other and are positioned on the
10 side walls of the resonance chamber 39 other than the side walls for the transducer which creates the standing waves in direction x . The direction y of the additional standing wave is perpendicular to the flow direction.

 Preferably, the pump which controls the flow rate to the resonance chamber 39 is positioned at the exit pipe only and the entrance pipe is directly
15 connected to the reaction chamber 22, which contains the suspension liquid from which the cells are to be separated.

 Preferably, the inner dimensions of the circular, or alternatively rectangular, shaped entrance tube are close to, or equal to, the inner dimensions of the preferably square-shaped cross section of the vessel for the resonance
20 chamber 39. The entrance tube is also the settling tube of the separated particles. In one embodiment, at least two sets of baffles are arranged inside the settling tube 23. The cross section of the baffles, perpendicular to the flow direction, of such a set is grid shaped, the grid frequency being in the range of 1.5 - 5 grids per cm in one embodiment. The length, and the flow direction, of each set is in
25 the range of 1 - 5 cm and the space in between two adjacent baffles is in the range of 1 - 5 cm.

 According to a further alternative embodiment, the suspension liquid within the resonance chamber 39 is divided into at least two sections, referred to as suspension sections S_i ($i=1\dots k$, $k\geq 2$) by at least one separation
30 layer F essentially perpendicular to the direction x of the standing wave. referred to as the film layer, f . The film layer F preferably consists of a material with a specific acoustic impedance (Z_F) close to the specific acoustic impedance (Z_S) of the suspension. The thickness (x_F) of the film layer being either small compared to the dimension of a quarter of the wavelength or close to, or equal to,
35 the half-wavelength for the exciting frequency (f_e). The suspension flow direction is in a downward direction on one side of the film F and in an upward direction, against gravity on the other side of the film F , resulting in temperature

distributions (T_{iz}) in the regarded sections S_i , such temperature distributions (T_{iz}) resulting in said temperature distribution (T_z) in direction z , averaged in direction x across all the suspension sections S_i . That is, the temperature is averaged in a direction x across the liquid on both sides of the film layer F .

5 Alternatively, two or more film layers F can be used, both parallel to each other and creating a serpentine path for the liquid from the chamber 22 to outlet port 24. For example, the fluid may travel upward for the first one-third of the resonance chamber 39, downward in the middle region of the resonance chamber 39, and upward in the final region.

10 Preferably, the suspension liquid includes biological cells suspended in a liquid which contains desired products, and the maximum acoustic particle velocity amplitude within the suspension liquid is selected at a value which does not result in damage to the viable biological cells. Preferably, the composite reactor 39 is mounted on a bioreactor growing mammalian cells
15 suspended in a nutrient solution, which may contain desired products. The solution is separated from the viable cells within the resonator 39, the solution being harvested after the exit pipe 24 from the resonator 39, with the viable cells being recycled by descending through the settling tube 23 and back into the bioreactor tube 22. Preferably, only materials biocompatible to such a cell
20 culture are in contact with the suspension liquid.

Preferably, the flow velocity of the suspension liquid through the suspension chamber 39 is selected to be of a value which results in a separation significantly higher for viable cells than for non-viable cells. Thus, an increase in the viability of separated cells is achieved. Separation efficiency is defined as
25 the ratio of the number of cells being separated by the liquid by acoustically induced aggregation and sedimentation to the number of cells entering the resonator within the same time period. Viability is defined as the fraction of viable cells compared to the total number of cells.

While several specific embodiments have been described, the
30 invention and claims are not limited in scope to these specific embodiments. Rather, equivalent structures and methods can be used that incorporate the inventive concepts of various structures. The features of the various embodiments may also be combined in many different ways to practice the invention. The embodiment of Figures 8-13 need not use the transducer
35 structure of Figures 1-7 that is designed to avoid excitation of the Eigenfrequencies of the transducer, but could use the transducer structures of the prior art if desired. Similarly, the transducer design and selection of driving

frequencies described with respect to Figures 1-7 can be used in many structures in addition to the structures of Figures 8-13.

Claims

1. Apparatus for separating dispersed particles from a liquid by means of applying a resonant ultrasonic sound field in a multilayered composite resonator, said acoustically coupled layers are formed in the propagation direction of the acoustic wave by at least a piezoelectric transducer, a vessel containing the dispersion and an acoustic mirror, whereby said transducer is driven by an electrical power generator with a high frequency within the range of the half-value bandwidth of a characteristic high overtone quasiharmonic composite resonance-frequency, characterized in that the thickness and relative position of the transducer layer is chosen so that the driving frequency is outside of any of the intervals defined between a lower limit value, which is defined as the regarded electrically excitable quasiharmonic Eigen-frequency of the transducer minus the ratio of said Eigen-frequency over ten times the quasiharmonic number, and a higher limit value, which is defined as said Eigen-frequency plus the ratio of said Eigen-frequency over ten times the quasiharmonic number.

2. Apparatus of claim 1, characterized in that the thickness and relative position of the transducer layer being chosen with regard to the driving frequency to produce a vanishing acoustic particle velocity amplitude in the interface plane between the transducer and the dispersion.

3. Apparatus of claims 1 or 2, characterized in that the transducer is in contact with the dispersion only at one side, the inner side, whereby the outer interface plane of the transducer serves as first terminating reflecting plane and the outer interface plane of the acoustic mirror serves as second terminating reflecting plane.

4. Apparatus of claims 1 or 2, characterized in that the transducer is in contact with the dispersion at both sides and two separate mirrors are terminating the resonator, whereby the outer interface plane of the first mirror serves as first terminating reflecting plane and the outer interface plane of the second mirror serves as second terminating reflecting plane.

5. Apparatus of claim 3, characterized in that the transducer is comprised of a piezoelectric solid layer with electrodes, referred to as active layer, and a non-piezoelectric layer, referred to as passive layer, whereby:

the active layer is of a thickness which causes a spatial phase shift of the acoustic particle velocity amplitude, said phase shift being equal to an odd multiple of the number π ;

the passive layer is of a thickness which causes a spatial phase shift of the acoustic particle velocity amplitude, said phase shift being close to or equal to an odd multiple of half of the number π ; and

the passive layer is made of a material with a specific acoustic impedance close to, or higher than, the specific acoustic impedance of the active layer.

6. Apparatus of claim 4, characterized in that the transducer is comprised of one piezoelectric solid layer with electrodes, referred to as active layer, and two non-piezoelectric layers, referred to as passive layers, whereby:

the active layer is placed in between the two passive layers;

the active layer is of a thickness which causes a spatial phase shift of the acoustic particle velocity amplitude, said phase shift being close to or equal to an odd multiple of the number π ;

the first passive layer is of a thickness which causes a first phase shift of an odd multiple of half of the number π , and the second passive layer is of a thickness which causes a second phase shift of an odd multiple of half of the number π , whereby the thicknesses of the passive layers have preferably the same value; and

said passive layers are made of a material with a specific acoustic impedance close or, or higher than, the specific acoustic impedance of the active layer.

7. Apparatus of claim 5, characterized in that the passive layer of the transducer forms one wall of the vessel.

8. Apparatus of claim 3, characterized in that the mirror forms one wall of the vessel.

9. Apparatus of claim 4, characterized in that the mirrors form opposite walls of the vessel.

10. Apparatus of claim 3, characterized in that the mirror includes a piezoelectric solid layer with electrodes, referred to as active layer, and the amplitude of the electrical signal produced between the electrodes of the active layer is used as criterion for controlling the exciting frequency of the electrical power generator towards the value of a quasiharmonic composite resonance frequency in that the amplitude of the electrical signal is maintained at a maximum value.

11. Apparatus of claim 10, characterized in that:

said active layer of the mirror is of a thickness which causes a spatial phase shift of the acoustic particle velocity amplitude, said phase shift being close to or equal to an odd multiple of the number π ;

the active layer of the mirror is acoustically coupled with a non-piezoelectric layer, referred to as passive layer, with a thickness causing a phase shift of the acoustic particle velocity amplitude, said phase shift being close to or equal to an odd multiple of half of the number π ; and

the passive layer is made of a material with a specific acoustic impedance close to, or higher than, the specific acoustic impedance of the active layer.

12. Apparatus of claim 11, characterized in that said passive layer of the mirror forms one wall of the vessel.

13. Apparatus of claims 5, 6 or 11, characterized in that said active layer is formed by a mosaic-like structure of acoustically parallel piezoelectric plates of circular, rectangular or quadratic shape and of identical thickness bonded upon the piezoelectrically passive layer.

14. Apparatus of claims 5, 6 or 11, characterized in that the piezoelectric plate material is Lead-Zirconate-Titanate ceramic or Lithium-Niobate monocrystal.

15. Apparatus of claim 13, characterized in that said passive layer is an electrically insulating dielectric layer and the electrodes of the piezoelectric plates are at least in part electrically connected in series by connecting electrode layers which are deposited onto the passive layer, said connecting electrode layers are made

of a thickness corresponding to a spatial phase shift of the acoustic particle velocity amplitude smaller than $1/16$ of the number π .

16. Apparatus of claims 5, 6 or 11, characterized in that the piezoelectrically active layer is made of a Polyvinylidene Fluoride foil.

17. Apparatus of claims 5, 6 or 11, characterized in that said piezoelectrically passive layer consists of an odd multiple of passive sublayers, whereby:

the thickness of each sublayer causes a spatial phase shift of the acoustic particle velocity amplitude, said phase shift being close to or equal to an odd multiple of half of the number; and

said odd multiple of passive layers are of alternating high and low acoustic impedance, but starting and ending with high values close to or higher than the specific acoustic impedance of the active layer.

18. Apparatus of claims 1, 2, 5 or 6, characterized in that the fine tuning of the exciting frequency of the electrical power generator towards the value of the quasiharmonic composite resonance frequency is made by an automatic frequency control, which utilizes the root mean square power consumption of the composite resonator as criterion for controlling, whereby the root mean square power consumption is maintained at a relative maximum value.

19. Apparatus of claim 7, characterized in that an additional wave guide layer, consisting of a fluid, is placed between the passive layer of the transducer and the dispersion, and such waveguide layer is separated from the dispersion by an acoustically transparent wall.

20. Apparatus of claim 19, characterized in that the sidewalls of said waveguide layer being equipped with an entrance and exit pipe and the fluid being circulated.

21. Apparatus of claims 19 or 20, characterized in that the tuning of the excitation frequency is switched repeatedly between, five to twelve, adjacent, closely spaced composite resonance frequencies.

22. Apparatus of claim 5, characterized in that:

a totally reflecting retro-reflector forms one wall of the vessel, such retro-reflector being formed by two plates at right angle to each other and tilted by 45° to the direction of sound propagation;

the acoustic parameters of the material of the retro-reflector being of a value that the total reflection condition at the interface between dispersion and reflector is fulfilled for the tilt angle between the reflector plates and the longitudinal direction being equal 45° ; and

the flow of the dispersion being oriented parallel to these plates and perpendicular to the longitudinal direction; whereby

the virtual total reflection plane of the equivalent one-dimensional resonator defines the effective layer thickness of the dispersion.

23. Apparatus of claim 5, characterized in that two symmetric, totally reflecting retro-reflectors form opposite walls of the vessel, the acoustic parameters of the material of the retro-reflectors being of a value that the total reflection condition at the interfaces between the respective dispersions and reflectors is fulfilled, and the flow of the dispersions being oriented perpendicular to the longitudinal direction, whereby the virtual total reflection planes of the equivalent one-dimensional resonator define the effective layer thicknesses of the dispersions.

24. Apparatus of claim 19, characterized in that the acoustically transparent wall with thickness producing a spatial phase shift of the acoustic particle velocity amplitude, which is much smaller than the half of the number π for the excitation frequency.

25. Apparatus of claim 19, characterized in that the acoustically transparent wall with thickness producing a spatial phase shift of the acoustic particle velocity amplitude, which is approximately equal to the number π for the excitation frequency.

26. Apparatus of claims 19, 24, or 25, characterized in that the acoustically transparent wall is made of a material with a specific acoustic impedance which is very close to specific acoustic impedance of the waveguide fluid.

27. An apparatus for separating dispersed particles from a liquid through the use of a resonant acoustic wave, comprising:

an acoustic resonation chamber having the liquid flowing therethrough;
an acoustic transducer and an acoustic mirror forming opposite sidewalls of the resonation chamber and positioned parallel to each other to generate an acoustic standing resonance wave within the acoustic resonation chamber; and

an electrical power generator means for driving the transducer at a selected frequency, the frequency for driving the transducer being selected that is offset from an electrically excitable Eigen-frequency of the transducer by a value greater than 10% of the Eigen-frequency of the transducer itself.

28. The apparatus according to claim 27 wherein the frequency for driving the transducer is selected to be approximately in the middle between two adjacent Eigen-frequencies of the transducer.

29. The apparatus according to claim 27, further including a second liquid flowing on two sides of the transducer such that the transducer simultaneously creates an acoustic standing resonance wave in the first and second liquid on both sides of the transducer.

30. A method of separating particles from a liquid, comprising:
passing the liquid containing the particles through an acoustic resonation chamber, the acoustic resonation chamber including an acoustic transducer and an acoustic mirror on opposite sidewalls; and

generating an acoustic standing resonance wave within the acoustic resonation chamber having a selected frequency that is different from an electrically excitable Eigen-frequency of the transducer by greater than an offset value, the offset value being 10% divided by the quasiharmonic number of the Eigen-frequency.

31. The transducer according to claim 30 in which the generated acoustic standing resonance wave is different from the electrically excitable Eigen-frequency of the mirror by at least 10%.

32. The method according to claim 30 in which the frequency of the generated acoustic standing wave is spaced approximately in the middle between two adjacent Eigen-frequencies of the transducer.

33. The method according to claim 30 in which the quasiharmonic number is two (2) and the offset value is 5%.

34. The method according to claim 30 in which the quasiharmonic number is four (4) and the offset value is 2.5%.

35. The method according to claim 30 in which the quasiharmonic number is five (5) and the offset value is 2%.

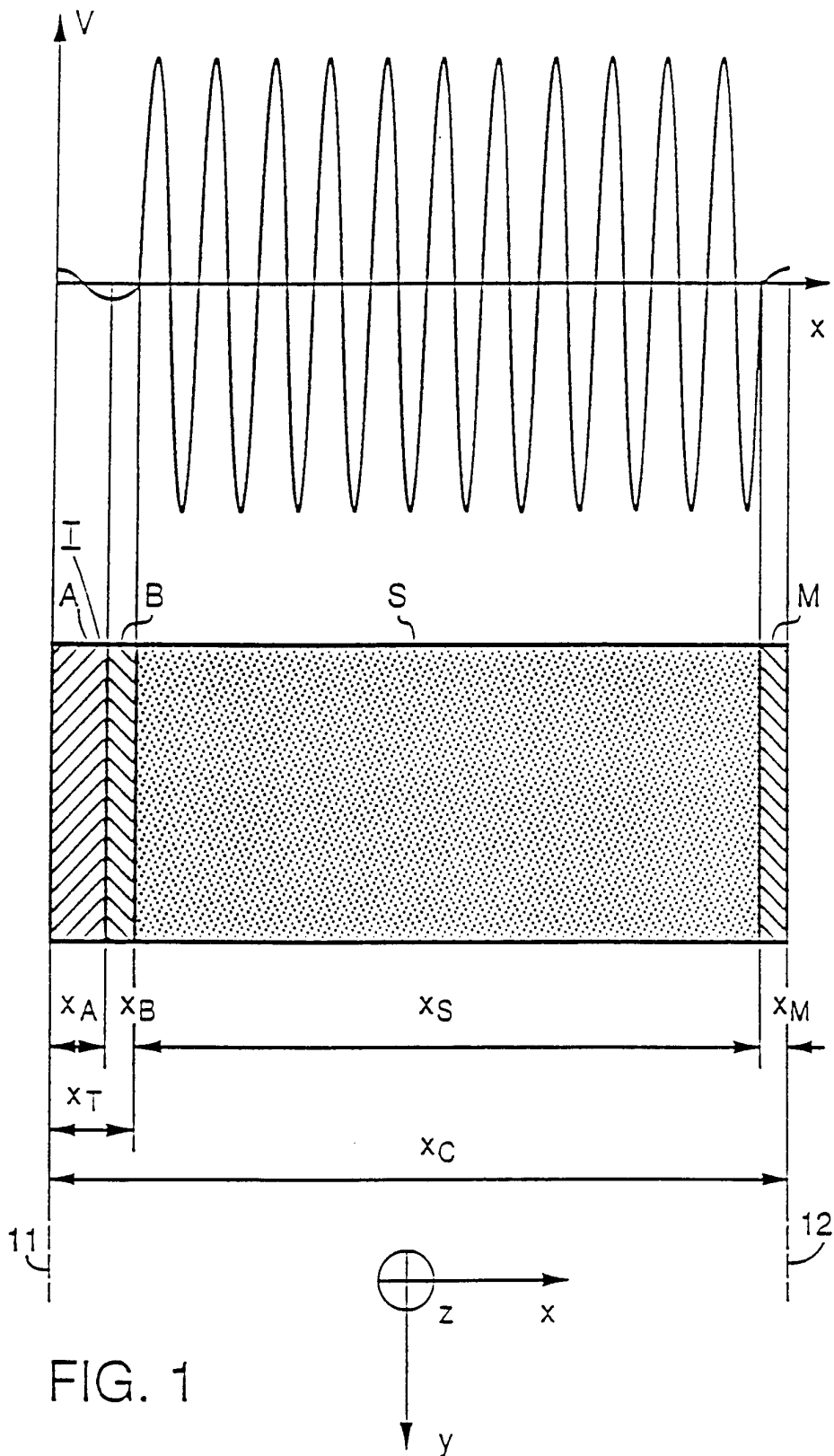

FIG. 1

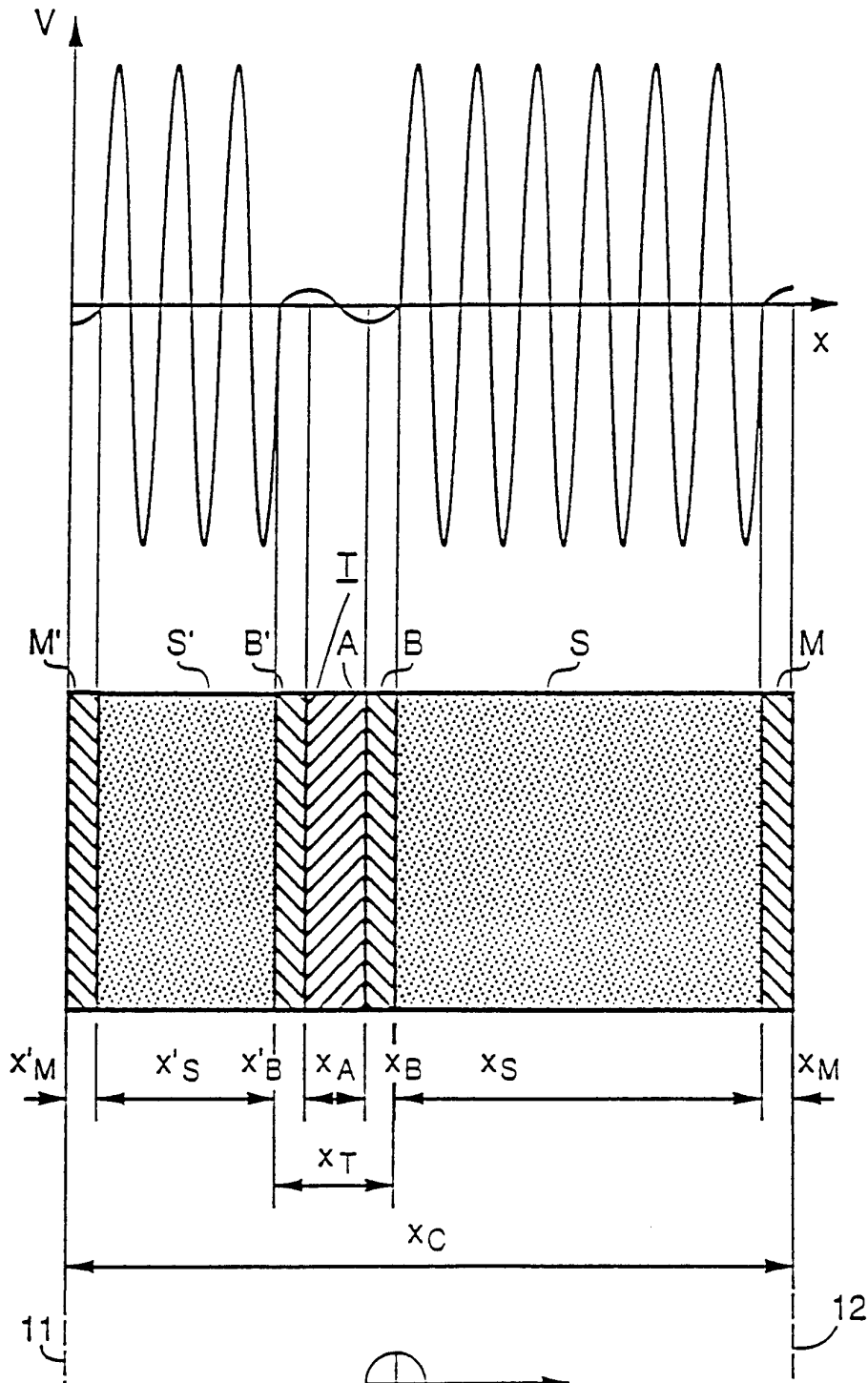

FIG. 2

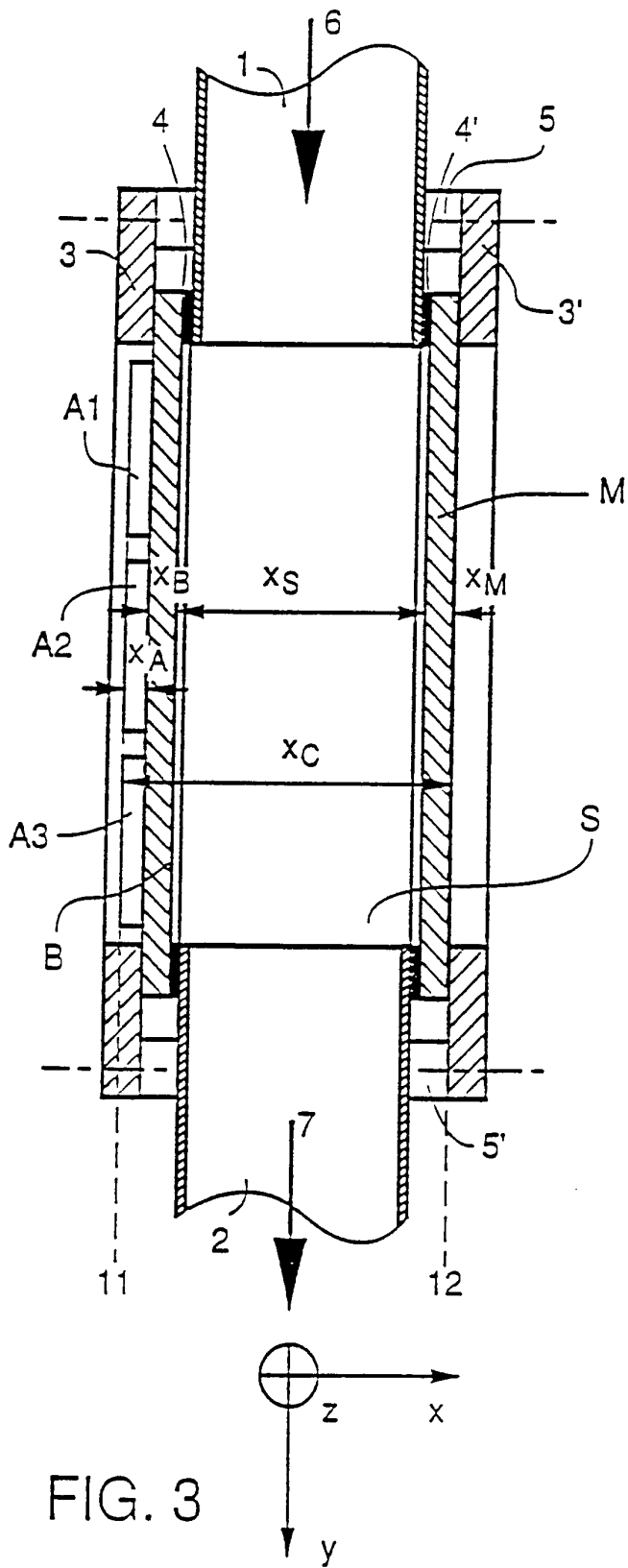

FIG. 3

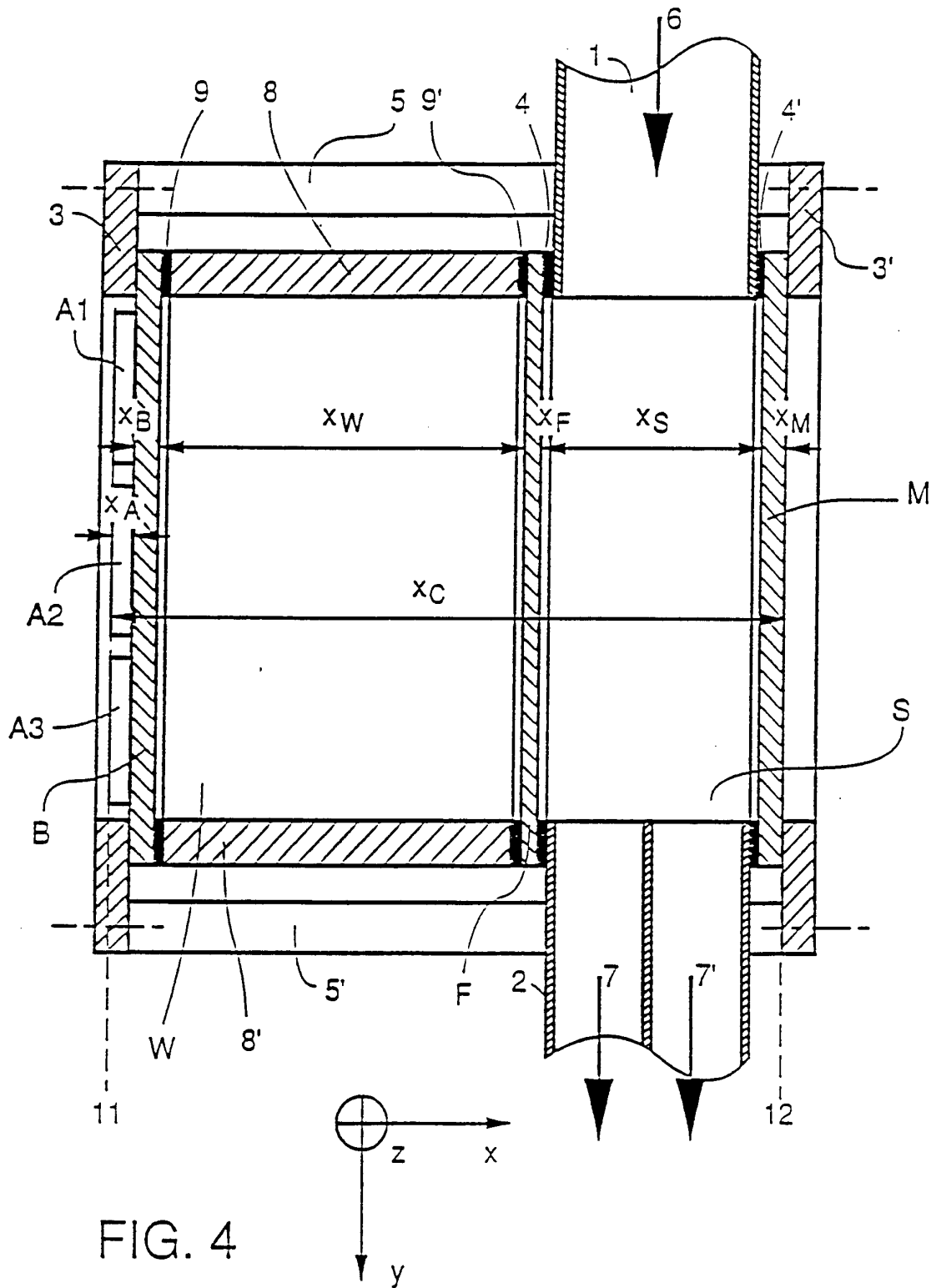

FIG. 4

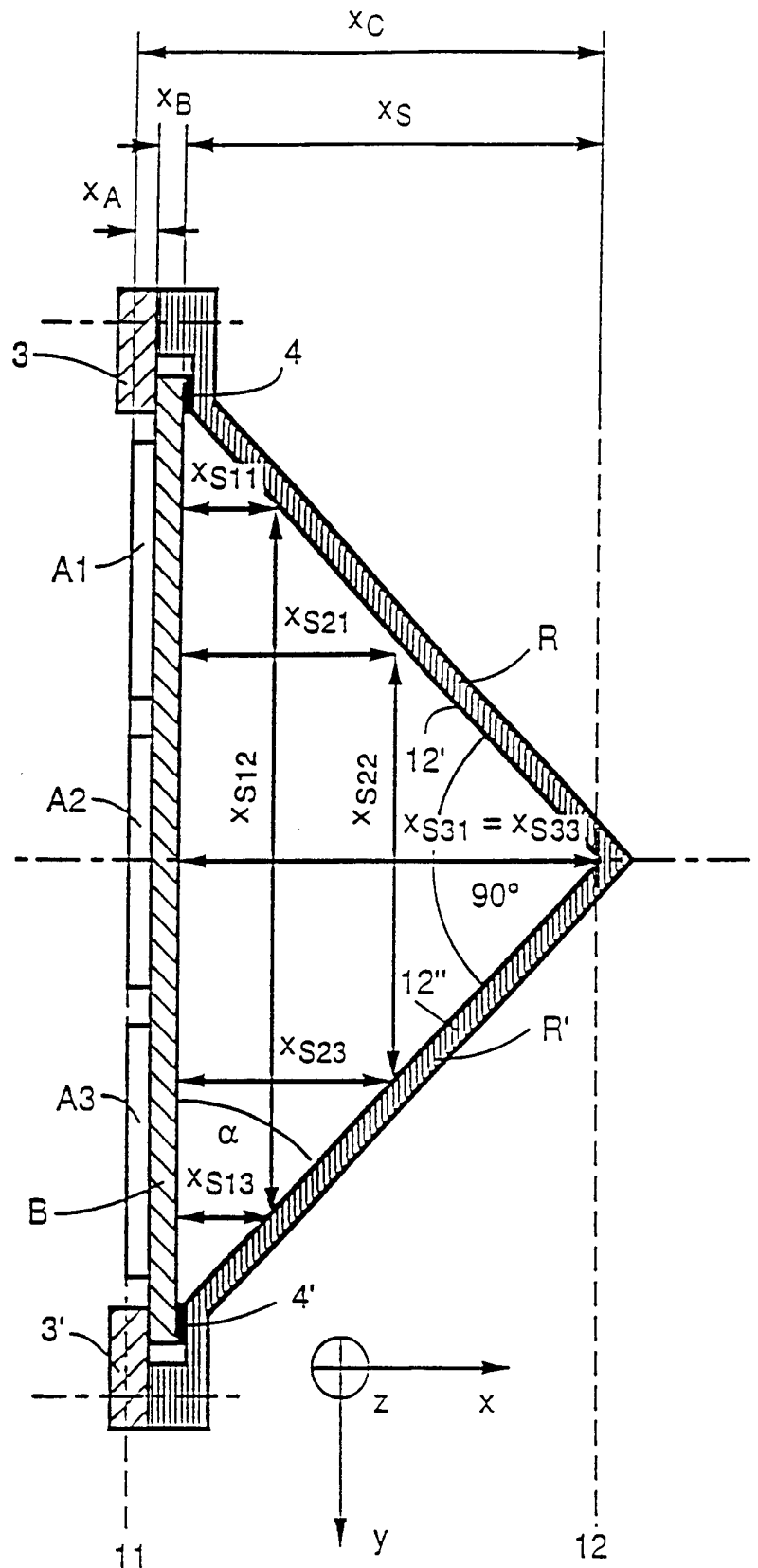

FIG. 5

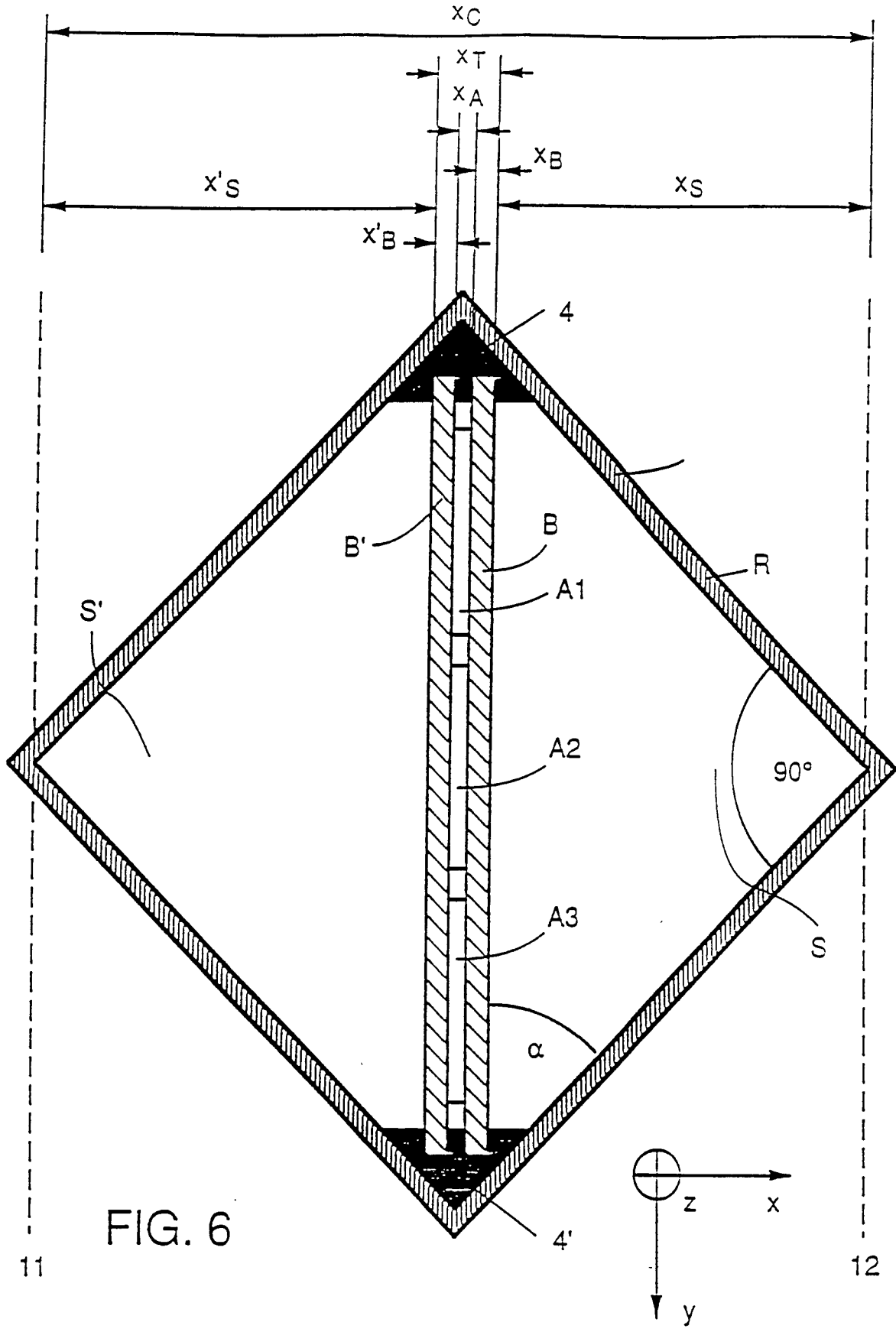

FIG. 6

11

12

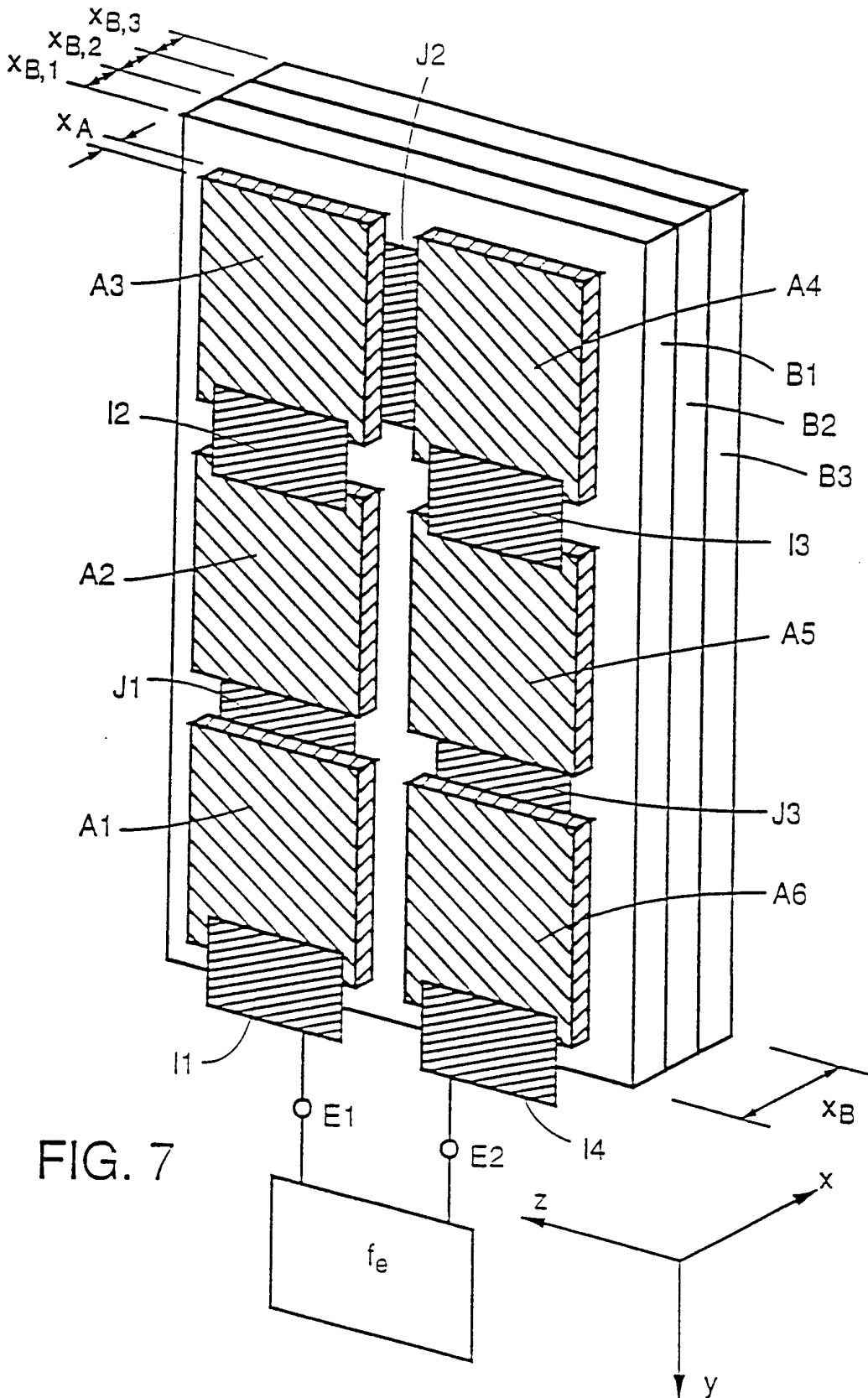

FIG. 7

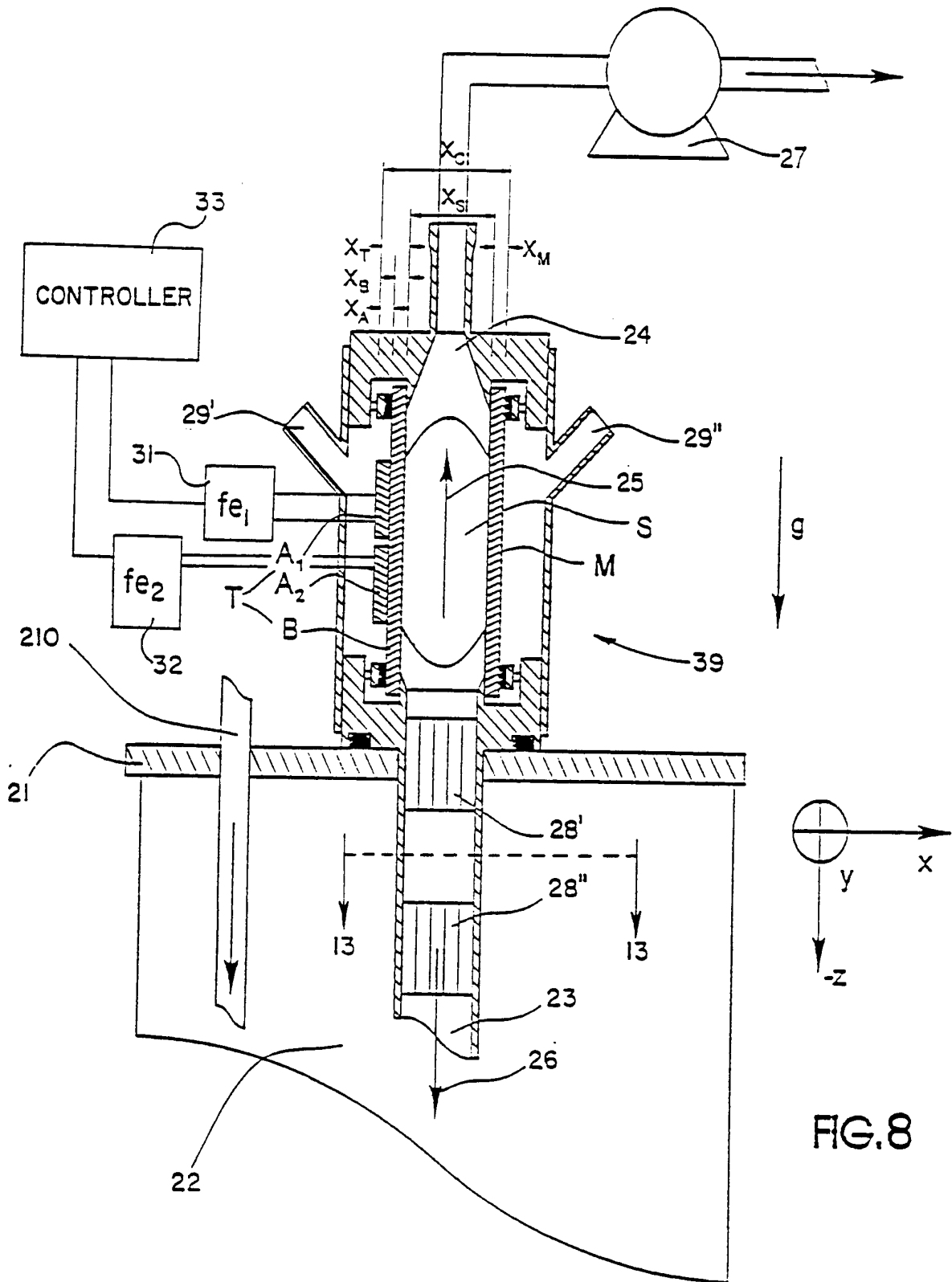

FIG.8

FIG. 9

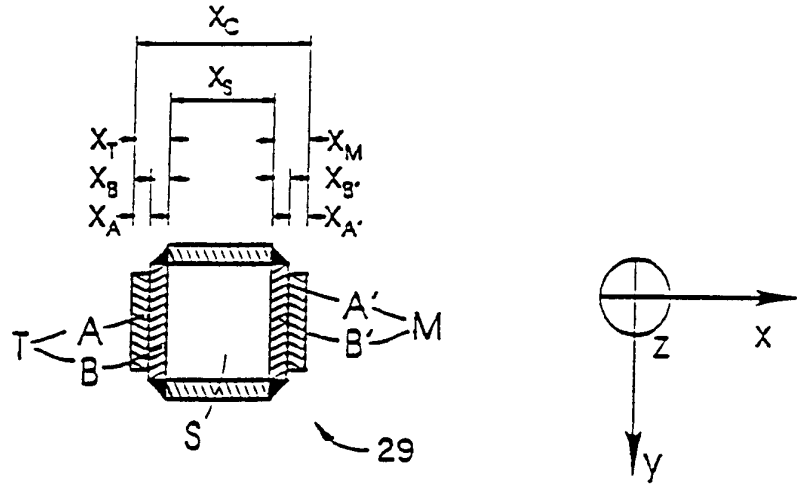
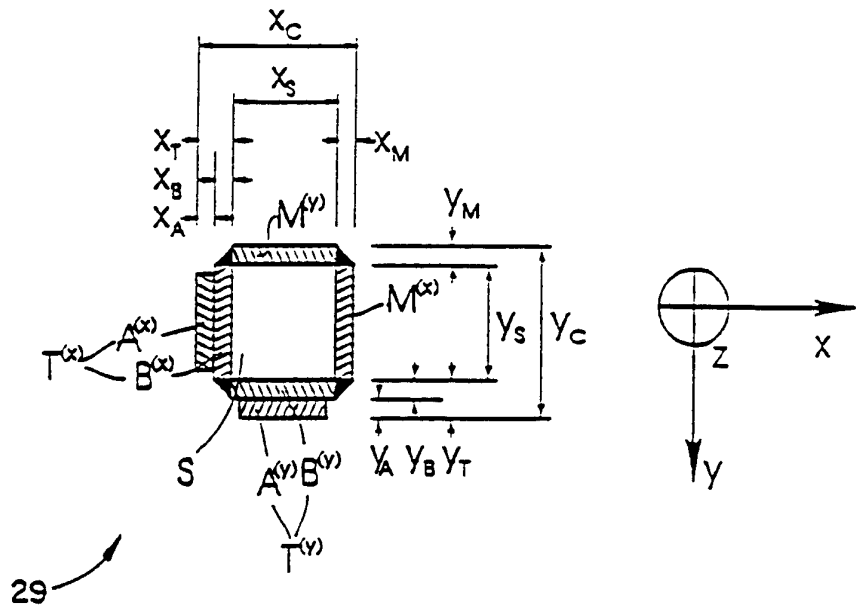

FIG. 10



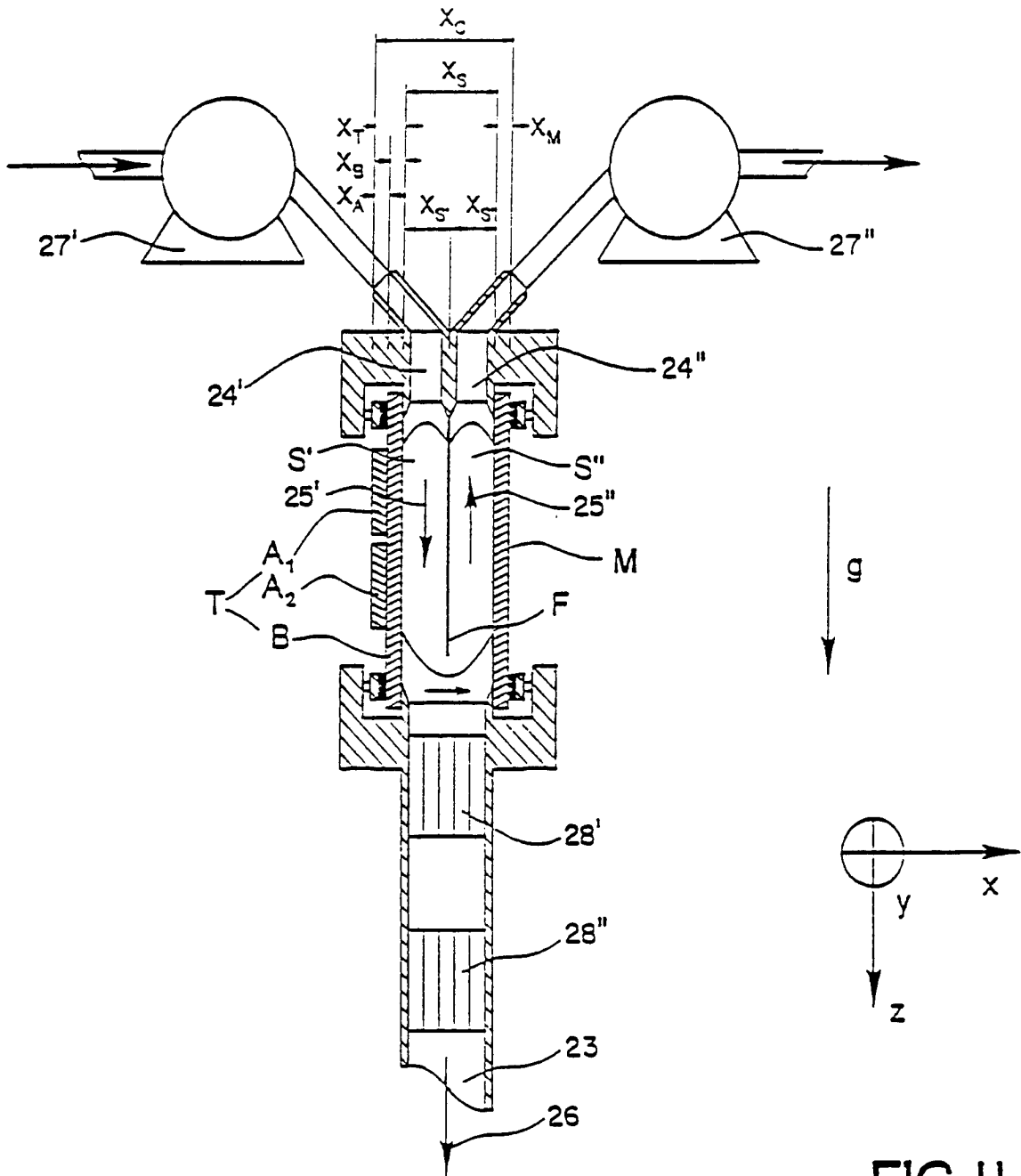

FIG. II

FIG. 12

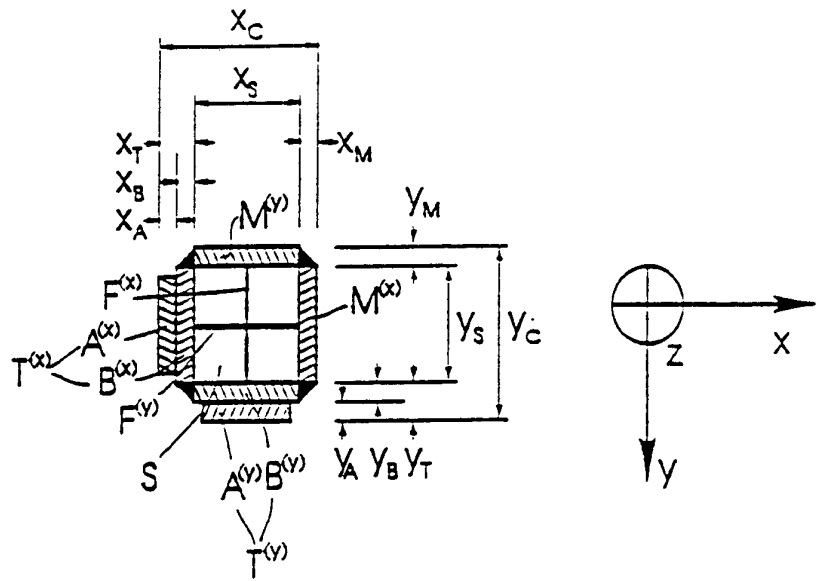
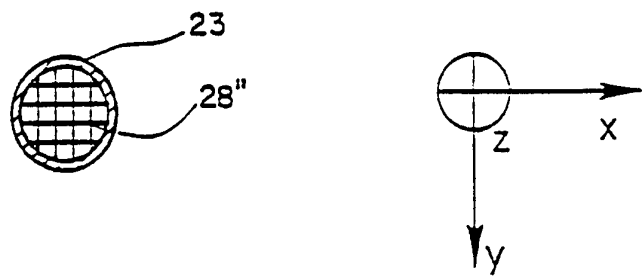

FIG. 13



INTERNATIONAL SEARCH REPORT

International Application No
PCT/IB 94/00143

A. CLASSIFICATION OF SUBJECT MATTER
IPC 5 B01D43/00 B01J19/10

According to International Patent Classification (IPC) or to both national classification and IPC

B. FIELDS SEARCHED

Minimum documentation searched (classification system followed by classification symbols)
IPC 5 B01D B01J

Documentation searched other than minimum documentation to the extent that such documents are included in the fields searched

Electronic data base consulted during the international search (name of data base and, where practical, search terms used)

C. DOCUMENTS CONSIDERED TO BE RELEVANT

Category *	Citation of document, with indication, where appropriate, of the relevant passages	Relevant to claim No.
A	WO,A,90 05008 (E.BENES ET AL.) 17 May 1990 cited in the application see the whole document ---	1-3,5, 7-13, 21-23
A	WO,A,88 09210 (W.STUCKART) 1 December 1988 see claims 1,3,21,30 & US,A,5 164 094 cited in the application ---	1,3,8,9, 16
A	FR,A,821 419 (METALLGESELLSCHAFT AG) 4 December 1937 see the whole document ---	1,6
	-/--	

Further documents are listed in the continuation of box C.

Patent family members are listed in annex.

* Special categories of cited documents :

- 'A' document defining the general state of the art which is not considered to be of particular relevance
- 'E' earlier document but published on or after the international filing date
- 'L' document which may throw doubts on priority claim(s) or which is cited to establish the publication date of another citation or other special reason (as specified)
- 'O' document referring to an oral disclosure, use, exhibition or other means
- 'P' document published prior to the international filing date but later than the priority date claimed

- 'T' later document published after the international filing date or priority date and not in conflict with the application but cited to understand the principle or theory underlying the invention
- 'X' document of particular relevance; the claimed invention cannot be considered novel or cannot be considered to involve an inventive step when the document is taken alone
- 'Y' document of particular relevance; the claimed invention cannot be considered to involve an inventive step when the document is combined with one or more other such documents, such combination being obvious to a person skilled in the art.
- '&' document member of the same patent family

Date of the actual completion of the international search

13 October 1994

Date of mailing of the international search report

26 10. 94

Name and mailing address of the ISA

European Patent Office, P.B. 5818 Patentaan 2
NL - 2280 HV Rijswijk
Tel. (+ 31-70) 340-2040, Tx. 31 651 epo nl,
Fax: (+ 31-70) 340-3016

Authorized officer

Bertram, H

INTERNATIONAL SEARCH REPORT

International Application No
PCT/IB 94/00143

C.(Continuation) DOCUMENTS CONSIDERED TO BE RELEVANT

Category *	Citation of document, with indication, where appropriate, of the relevant passages	Relevant to claim No.
A	US,A,4 759 775 (S.C.PETERSON ET AL.) 26 July 1988 cited in the application see claims 5,6 -----	1

INTERNATIONAL SEARCH REPORT

Information on patent family members

International Application No PCT/IB 94/00143
--

Patent document cited in search report	Publication date	Patent family member(s)	Publication date
WO-A-9005008	17-05-90	AT-B- 390739	25-06-90
		EP-A- 0400115	05-12-90
		US-A- 5225089	06-07-93
WO-A-8809210	01-12-88	AT-B- 389235	10-11-89
		AU-A- 1726288	21-12-88
		CA-A- 1320151	13-07-93
		DE-A- 3865526	21-11-91
		EP-A, B 0292470	23-11-88
		EP-A- 0362233	11-04-90
		US-A- 5164094	17-11-92
US-A-5164094	17-11-92	AT-B- 389235	10-11-89
		WO-A- 8809210	01-12-88
		AU-A- 1726288	21-12-88
		CA-A- 1320151	13-07-93
		DE-A- 3865526	21-11-91
		EP-A, B 0292470	23-11-88
		EP-A- 0362233	11-04-90
FR-A-821419		GB-A- 500271	
US-A-4759775	26-07-88	US-A- 4983189	08-01-91