



US00D362280S

# United States Patent [19]

[11] Patent Number: **Des. 362,280**

George

[45] Date of Patent: **\*\* Sep. 12, 1995**

- [54] TOY VEHICLE
- [75] Inventor: **Kevin M. George**, Cincinnati, Ohio
- [73] Assignee: **Tonka Corporation**, Pawtucket, R.I.
- [\*\*] Term: **14 Years**
- [21] Appl. No.: **26,754**
- [22] Filed: **Aug. 4, 1994**
- [52] U.S. Cl. .... **D21/137**
- [58] Field of Search ..... **D21/59, 71, 73-79, D21/128, 132, 134, 136, 137, 141; 446/427, 428, 456, 465, 470; 280/1.13, 8.28, 87.021**

- 3,842,532 10/1974 Nielsen ..... 446/470
- 4,300,308 11/1981 Ikeda .
- 4,969,851 11/1990 Rasmussen .
- 5,261,853 11/1993 Suto ..... 446/456

*Primary Examiner*—Terry A. Wallace  
*Assistant Examiner*—R. Barkai  
*Attorney, Agent, or Firm*—Kurt R. Benson

### [57] CLAIM

An ornamental design for a toy vehicle, as shown and described.

### DESCRIPTION

FIG. 1 is a perspective view of the toy vehicle showing my new design;  
 FIG. 2 is a bottom perspective view thereof;  
 FIG. 3 is a bottom plan view thereof;  
 FIG. 4 is a top plan view thereof;  
 FIG. 5 is a right side elevational view thereof;  
 FIG. 6 is a left side elevational view thereof;  
 FIG. 7 is a front elevational view thereof; and,  
 FIG. 8 is a rear elevational view thereof.

### [56] References Cited

#### U.S. PATENT DOCUMENTS

- |            |        |           |       |         |
|------------|--------|-----------|-------|---------|
| D. 264,107 | 4/1982 | Orenstein | ..... | D21/137 |
| D. 282,677 | 2/1986 | Arigaya   | ..... | D21/134 |
| D. 309,930 | 8/1990 | Asaeda    | ..... | D21/137 |
| D. 317,024 | 5/1991 | Yajima    | ..... | D21/137 |
| D. 317,336 | 6/1991 | Tsuchiya  | ..... | D21/137 |
| D. 317,485 | 6/1991 | Mochizuki | ..... | D21/137 |

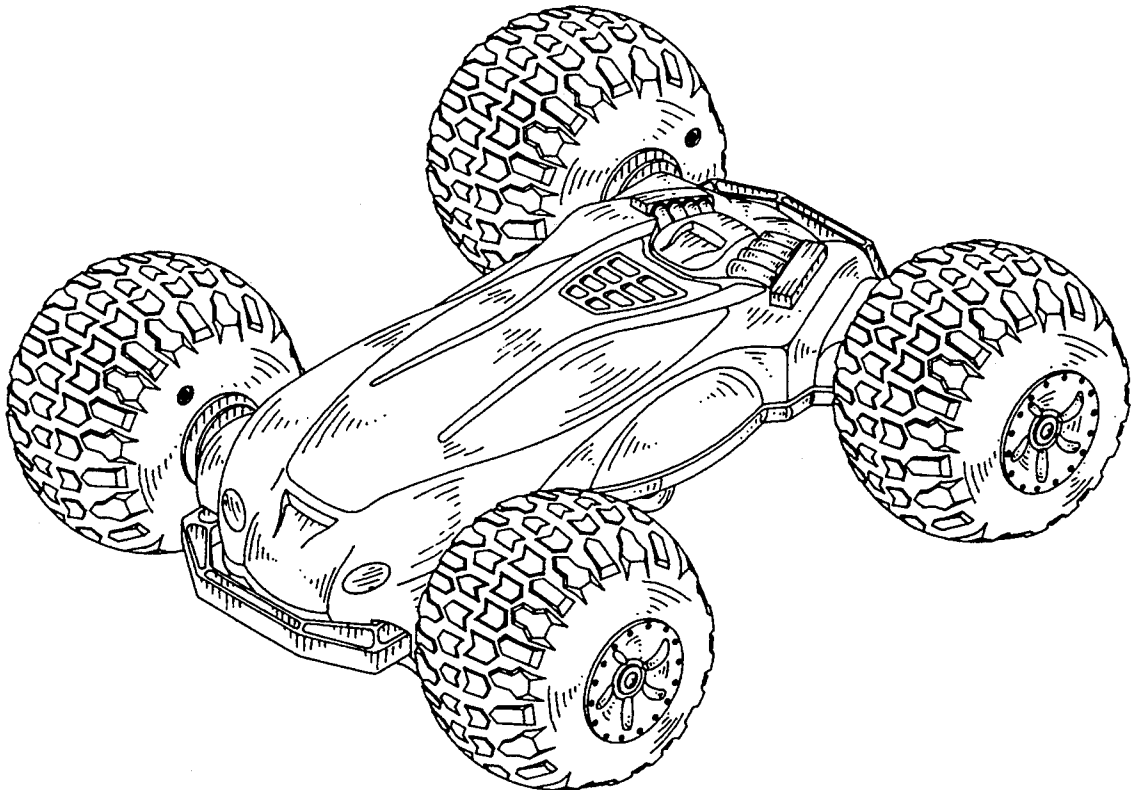

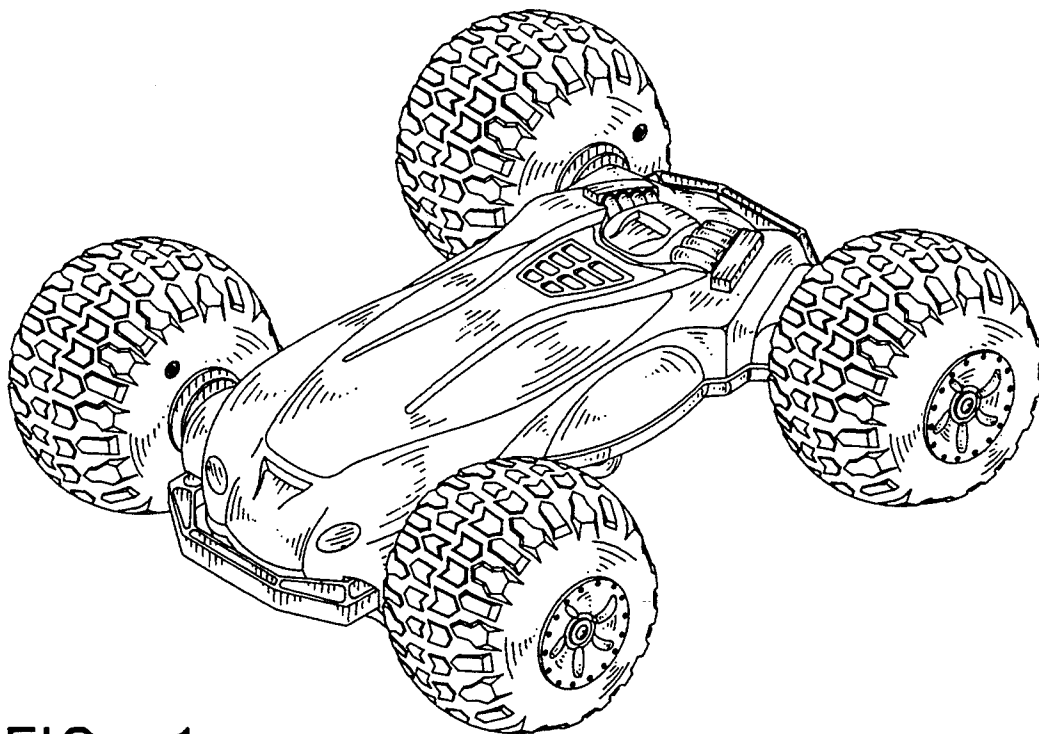

FIG. 1

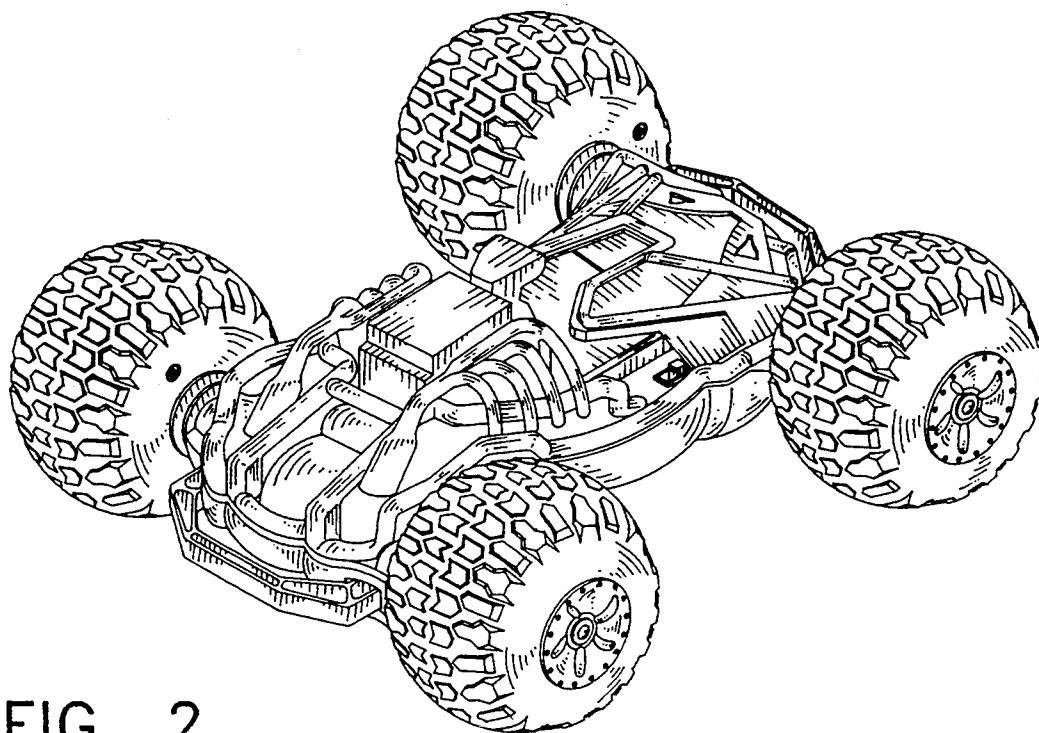

FIG. 2

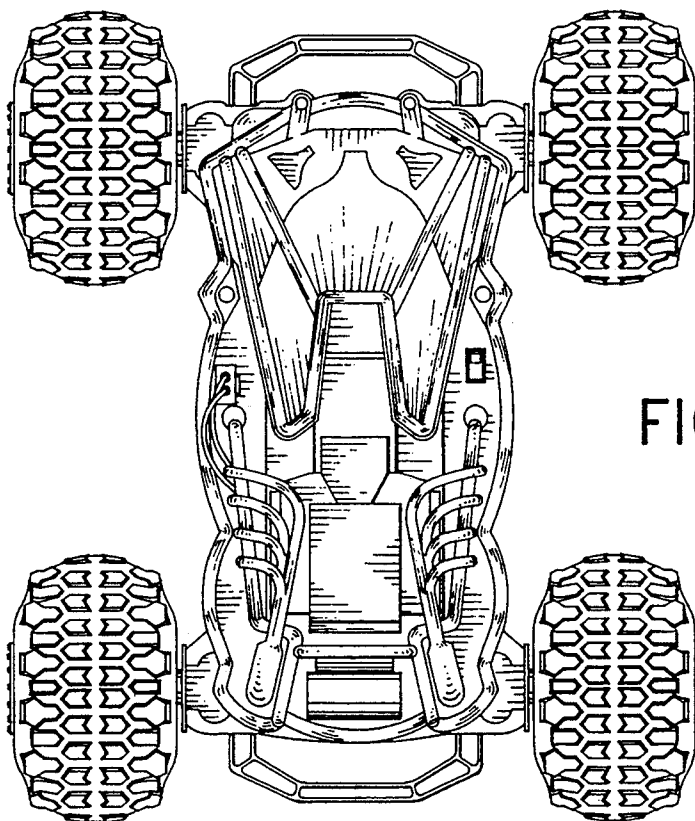

FIG. 3

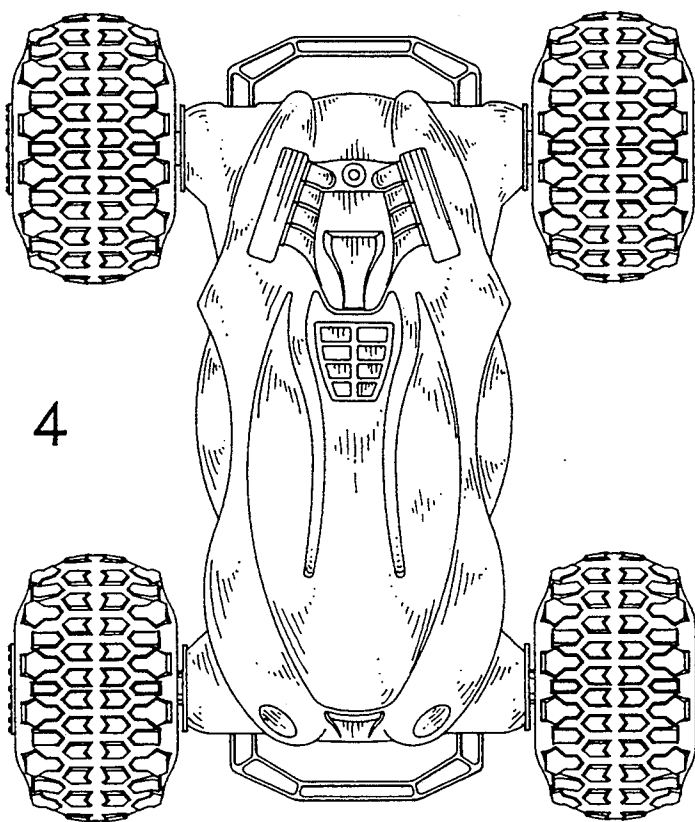

FIG. 4

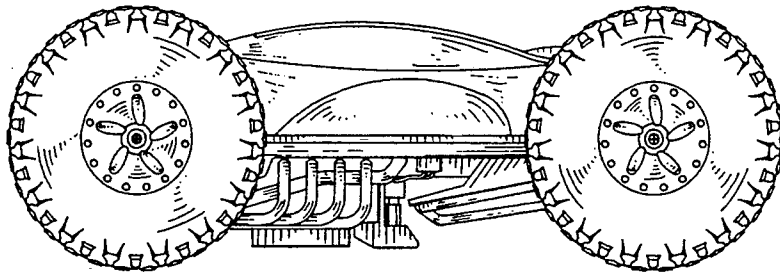

FIG. 5

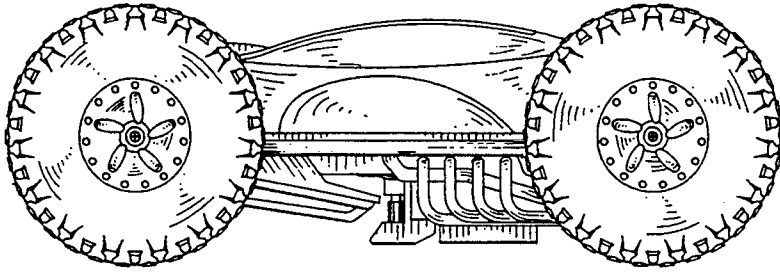

FIG. 6

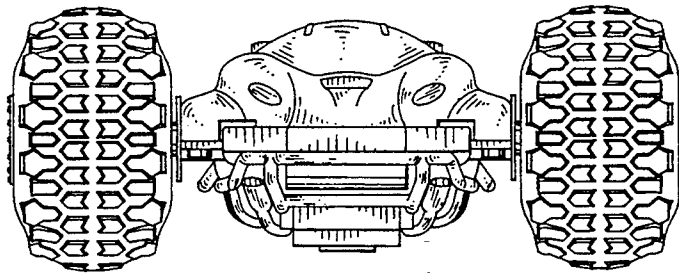

FIG. 7

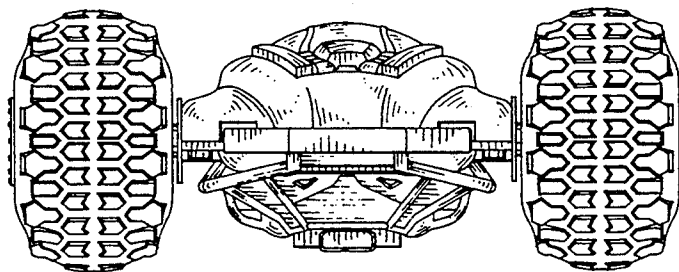

FIG. 8