

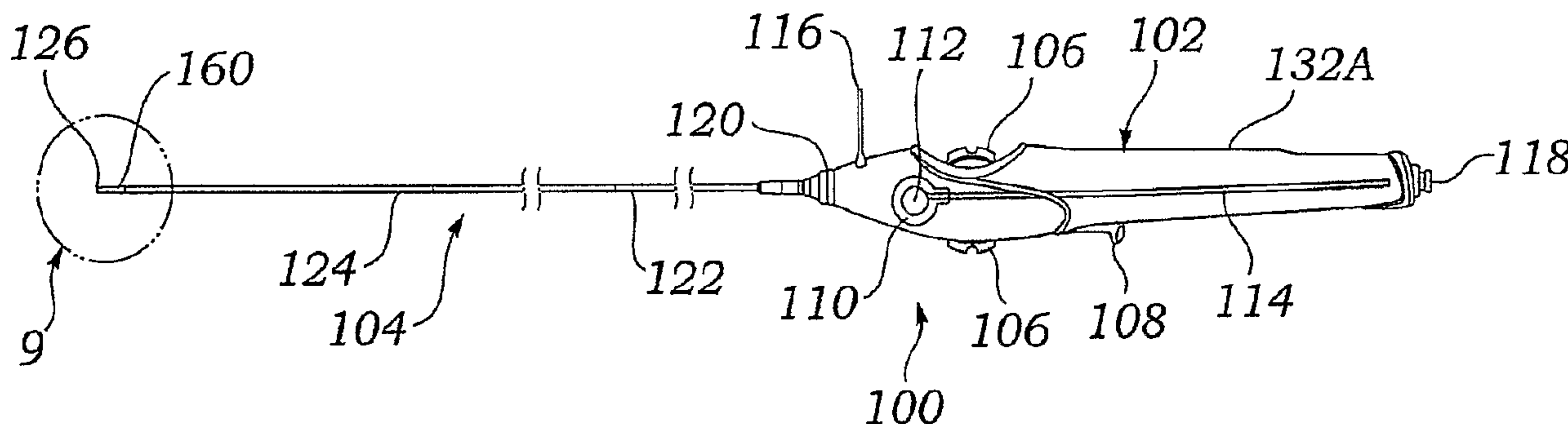

(86) Date de dépôt PCT/PCT Filing Date: 2007/01/12
 (87) Date publication PCT/PCT Publication Date: 2007/07/26
 (45) Date de délivrance/Issue Date: 2014/06/10
 (85) Entrée phase nationale/National Entry: 2008/06/17
 (86) N° demande PCT/PCT Application No.: US 2007/000834
 (87) N° publication PCT/PCT Publication No.: 2007/084370
 (30) Priorités/Priorities: 2006/01/13 (US60/759,136);
 2006/04/05 (US60/789,734)

(51) Cl.Int./Int.Cl. *A61F 2/95* (2013.01),
A61F 2/966 (2013.01)
 (72) Inventeurs/Inventors:
 JIMENEZ, TEODORO S., US;
 FULKERSON, JOHN, US;
 MAZZEI, RAFFAELE, US
 (73) Propriétaire/Owner:
 C.R. BARD INC., US
 (74) Agent: NORTON ROSE FULBRIGHT CANADA
 LLP/S.E.N.C.R.L., S.R.L.

(54) Titre : SYSTEME DE MISE EN PLACE D'UNE ENDOPROTHESE
 (54) Title: STENT DELIVERY SYSTEM



(57) Abrégé/Abstract:

One preferred embodiment includes a stent delivery system (100) including a retractable sheath and an outer stability sheath. The stability sheath freely rotates relative to the retractable sheath, relieving compression forces caused by twisting of stability sheath in when in a tortuous conformation.



(12) INTERNATIONAL APPLICATION PUBLISHED UNDER THE PATENT COOPERATION TREATY (PCT)

(19) World Intellectual Property Organization
International Bureau



(43) International Publication Date
26 July 2007 (26.07.2007)

PCT

(10) International Publication Number
WO 2007/084370 A1

(51) International Patent Classification:
A61F 2/84 (2006.01)

(21) International Application Number:

PCT/US2007/000834

(22) International Filing Date: 12 January 2007 (12.01.2007)

(25) Filing Language:

English

(26) Publication Language:

English

(30) Priority Data:

60/759,136 13 January 2006 (13.01.2006) US
60/789,734 5 April 2006 (05.04.2006) US

(71) Applicant (for all designated States except US): **EDWARDS LIFESCIENCES CORPORATION** [US/US];
One Edwards Way, Irvine, CA 92614 (US).

(72) Inventors; and

(75) Inventors/Applicants (for US only): **JIMENEZ, Teodoro, S.** [US/US]; 28 Reunion, Irvine, CA 92603 (US). **FULKERSON, John** [US/US]; 10 La Sinfonia, Rancho Santa Margarita, CA 92688 (US). **MAZZEI, Raffaele** [DE/US]; 1323 Eolus Ave., Encinitas, CA 92024 (US).

(74) Agent: **YADAV, Rajiv**; Edwards Lifesciences LLC, One Edwards Way, Irvine, CA 92614 (US).

(81) Designated States (unless otherwise indicated, for every kind of national protection available): AE, AG, AL, AM, AT, AU, AZ, BA, BB, BG, BR, BW, BY, BZ, CA, CH, CN, CO, CR, CU, CZ, DE, DK, DM, DZ, EC, EE, EG, ES, FI, GB, GD, GE, GH, GM, GT, HN, HR, HU, ID, IL, IN, IS, JP, KE, KG, KM, KN, KP, KR, KZ, LA, LC, LK, LR, LS, LT, LU, LV, LY, MA, MD, MG, MK, MN, MW, MX, MY, MZ, NA, NG, NI, NO, NZ, OM, PG, PH, PL, PT, RO, RS, RU, SC, SD, SE, SG, SK, SL, SM, SV, SY, TJ, TM, TN, TR, TT, TZ, UA, UG, US, UZ, VC, VN, ZA, ZM, ZW.

(84) Designated States (unless otherwise indicated, for every kind of regional protection available): ARIPO (BW, GH, GM, KE, LS, MW, MZ, NA, SD, SL, SZ, TZ, UG, ZM, ZW), Eurasian (AM, AZ, BY, KG, KZ, MD, RU, TJ, TM), European (AT, BE, BG, CH, CY, CZ, DE, DK, EE, ES, FI, FR, GB, GR, HU, IE, IS, IT, LT, LU, LV, MC, NL, PL, PT, RO, SE, SI, SK, TR), OAPI (BF, BJ, CF, CG, CI, CM, GA, GN, GQ, GW, ML, MR, NE, SN, TD, TG).

Published:

- with international search report
- before the expiration of the time limit for amending the claims and to be republished in the event of receipt of amendments

For two-letter codes and other abbreviations, refer to the "Guidance Notes on Codes and Abbreviations" appearing at the beginning of each regular issue of the PCT Gazette.

(54) Title: STENT DELIVERY SYSTEM

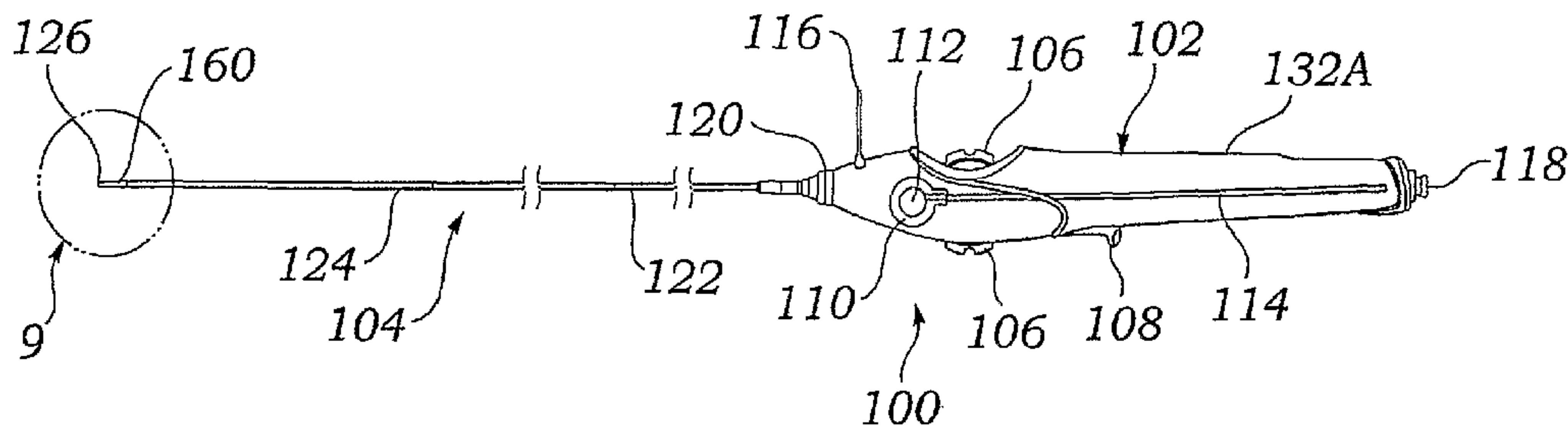

(57) Abstract: One preferred embodiment includes a stent delivery system (100) including a retractable sheath and an outer stability sheath. The stability sheath freely rotates relative to the retractable sheath, relieving compression forces caused by twisting of stability sheath in when in a tortuous conformation.

WO 2007/084370 A1

STENT DELIVERY SYSTEM

RELATED APPLICATION

[0001] The present application claims priority to U.S. provisional application 60/759,136, filed January 13, 2006 and provisional application 60/789,734, filed April 5, 2006.

FIELD OF INVENTION

[0002] This invention relates broadly to medical devices. More particularly, this invention relates to an instrument for delivering a self-expanding stent into a mammalian body and controllably releasing the stent.

BACKGROUND OF THE INVENTION

[0003] Transluminal prostheses are widely used in the medical arts for implantation in blood vessels, biliary ducts, or other similar organs of the living body. These prostheses are commonly known as stents and are used to maintain, open, or dilate tubular anatomical structures.

[0004] The underlying structure of the stent can be virtually any stent design. There are typically two types of stents: self-expanding stents and balloon expandable stents. Stents are typically formed from malleable metals, such as 300 series stainless steel, or from resilient metals, such as super-elastic and shape memory alloys, e.g., Nitinol™ alloys, spring stainless steels, and the like. They can also, however, be formed from non-metal materials such as non-degradable or biodegradable polymers or from bioresorbable materials such as levorotatory polylactic acid (L-PLA), polyglycolic acid (PGA) or other materials such as those described in U.S. Patent No. 6,660,827.

- 2 -

[0005] Self-expanding stents are delivered through the body lumen on a catheter to the treatment site where the stent is released from the catheter, allowing the stent to automatically expand and come into direct contact with the luminal wall of the vessel. Examples of a self-expanding stent suitable for purposes of this invention are disclosed in U.S. Publication No. 2002/0116044. For example, the self-expanding stent described in U.S. Publication No. 2002/0116044 comprises a lattice having two different types of helices forming a hollow tube having no free ends. The first type of helix is formed from a plurality of undulations, and the second type of helix is formed from a plurality of connection elements in series with the undulations, wherein the connection elements connect fewer than all of the undulations in adjacent turns of the first type of helix. The first and second types of helices proceed circumferentially in opposite directions along the longitudinal axis of the hollow tube. This design provides a stent having a high degree of flexibility as well as radial strength. It will be apparent to those skilled in the art that other self-expanding stent designs (such as resilient metal stent designs) could be used according to this invention.

[0006] The stent may also be a balloon expandable stent which is expanded using an inflatable balloon catheter. Balloon expandable stents may be implanted by mounting the stent in an unexpanded or crimped state on a balloon segment of a catheter. The catheter, after having the crimped stent placed thereon, is inserted through a puncture in a vessel wall and moved through the vessel until it is positioned in the portion of the vessel that is in need of repair. The stent is then expanded by inflating the balloon catheter against the inside wall of the vessel. Specifically, the stent is plastically deformed by inflating the balloon so that the diameter of the stent is increased and remains at an increased state, as described in U.S. Patent No. 6,500,248 B1.

- 3 -

[0007] Stents are delivered to an implant site with the use of a delivery system. Delivery systems for self-expanding stents generally comprise an inner tubular member on which the stent is loaded and which may be fed over a guidewire, and an outer tubular member or jacket longitudinally slidable over the inner tubular member and adapted to extend over the stent during delivery to the implant site. The jacket is retracted along the inner tubular member to release the self-expanding stent from the inner tubular member.

[0008] In several available delivery systems, the jacket and inner member are freely movable relative to each other and must be separately manually held in the hands of the physician. After the distal end of the system is located at the implant site, the inner member must be held still to prevent dislocation. However, it is very difficult to maintain the position of the inner member while moving the outer member to deploy the stent. As such, the degree of control during deployment is limited. Under such limited control there is a tendency for the stent to escape from the inner member before the jacket is fully retracted and jump from the desired deployment site. This may result in deployment of the stent at a location other than the desired implant site.

[0009] A handle may be provided to move the outer tubular member relative to the inner tubular member with greater control. For example, Medtronic Inc., utilizes a handle which can lock the inner tube and outer jacket relative to each other and effect relative movement of the two to cause deployment of the stent. However, such handles have several shortcomings. First, the handle is not particularly well suited to short stents as there is little fine control. Second, the handle is not well-suited to long stents, e.g., above 90 mm in length, as the linear control requires the operator to change his or her grip during deployment in order to generate the large relative motion of the tubular components. Third, it is possible for the stent to automatically release before the jacket

- 4 -

is fully retracted from over the stent. This is because the super-elastic expansion of the stent causes the stent to slip distally out of the deployment system before the operator retracts the sheath. The result can be an unintentionally rapid and possibly uneven deployment of the stent. Fourth, without reference to a fluoroscope monitoring the stent, there is no manner to determine from the proximal end of the instrument the progress of stent deployment. Fifth, the construction of the inner tubular member and outer jacket may cause the inner member and jacket to be crushed during use. Furthermore, the inner tubular member is subject to compressive force during deployment and may deform while moving the stent from the desired deployment location.

[0010] Another stent delivery system can be seen in the U.S. Patent Publication No. 2004/0006380 entitled Stent Delivery System and U.S. Patent Publication No. 2005/0273151 also entitled Stent Delivery System. Like other available stent delivery systems, the designs in these publications provide a single actuating mechanism for moving the outer jacket relative to the inner tubular member, specifically shown as a thumbwheel.

[0011] In these designs, the retraction speed of the jacket member is limited by both the user's ability to actuate the thumbwheel (i.e. the speed the user can move their thumb) and the retraction ratio of the thumbwheel (i.e. the ratio of thumbwheel movement/rotation to jacket retraction). This "speed limit" can be especially difficult for a user when deploying longer stents such as those between 100 and 200 mm in length, since it greatly increases the stent deployment time. Further, the

- 5 -

thumbwheel can have only one retraction ratio, which increases the difficulty of retracting the jacket at substantially different speeds.

[0012] What is needed is a stent delivery system that overcomes the limitations of the prior art and facilitates the retraction of the jacket at
5 different speeds. Further, a stent delivery system is needed that provides the user with greater dynamic control of the jacket to increase delivery precision while reducing the deployment time.

OBJECTS AND SUMMARY OF THE INVENTION

[0013] It is therefore an object of the invention to provide a stent
10 delivery system that permits a high degree of control during the deployment of the stent.

[0014] It is another object of the invention to provide a stent delivery system that more easily retracts an outer jacket at different speeds.

[0015] It is another object of the invention to provide a stent delivery
15 system that has multiple controls for retracting an outer jacket.

[0016] It is yet another object of the invention to provide a stent delivery system with independent outer jacket retraction controls that allow switching from one control to another without a lag in the jacket retraction.

[0017] The present invention seeks to achieve these and other
20 objects in one preferred embodiment by providing a stent delivery system having three independent controls for retracting an outer jacket to deliver a stent or similar prosthesis. More specifically, the stent delivery system provides a thumbwheel, a thumb lever, and a pull ring
25 which each engage a distal portion of the outer jacket. When any of the three controls are actuated, they create a proximal force on the jacket,

- 6 -

retracting the jacket and releasing a stent on the distal end of the delivery system.

[0018] Preferably, the thumbwheel and the thumb lever retract the jacket by way of a cord within the handle of the delivery system that
5 engages a proximal portion of the jacket. The thumbwheel rotates a spool which winds up the cord and therefore causes the jacket to retract. The thumb lever effectively increases the path of the cord within the handle by moving against a region of the cord, also causing the jacket to retract. The pull ring is preferably connected to the proximal end of the
10 jacket, allowing the user to directly pull the jacket in a proximal direction.

[0019] Each of the jacket controls can be configured to provide the user with different retraction ratios (e.g. for every 1 cm of movement of the thumb lever the jacket retracts 2 cm). In this respect, the user can use different retraction controls at different stages in the delivery
15 procedure. For example, the user may wish to initially retract the jacket slowly to "flower" the stent, with the thumbwheel. However, once the stent has been flowered, the user may wish to more quickly retract the jacket with the lower ratio of the thumb lever or pull ring. In this respect, the stent delivery system allows the user to more easily retract the jacket
20 at different speeds during the delivery procedure.

[0020] Additional objects and advantages of the invention will become apparent to those skilled in the art upon reference to the detailed description taken in conjunction with the provided figures.

BRIEF DESCRIPTION OF THE DRAWINGS

25 **[0021]** Figure 1 illustrates a side view of a preferred embodiment of a delivery system according to the present invention;

- 7 -

[0022] Figure 2 illustrates an exploded perspective view of the delivery system of Figure 1;

[0023] Figure 3 illustrates a partially disassembled side view of the delivery system of Figure 1;

5 **[0024]** Figure 4 illustrates a partially disassembled perspective view of the delivery system of Figure 1;

[0025] Figure 5 illustrates a partially disassembled perspective view of the delivery system of Figure 1;

10 **[0026]** Figure 6 illustrates a side cross section view of a delivery portion of the delivery system of Figure 1;

[0027] Figure 7 illustrates a side cross section view of a distal end of the delivery portion of the delivery system of Figure 1;

[0028] Figure 8 illustrates a side cross section view of a strain relief member of the delivery system of Figure 1;

15 **[0029]** Figure 9 illustrates a perspective view of a spool of the delivery system of Figure 1;

[0030] Figure 10 illustrates a perspective view of a thumbwheel of the delivery system of Figure 1;

20 **[0031]** Figure 11 illustrates a perspective view of a slider of a handle portion of Figure 1;

[0032] Figure 12 illustrates a perspective view of a slider of the delivery system of Figure 1;

[0033] Figure 13 illustrates a side view of the slider of Figure 12;

- 8 -

[0034] Figure 14 illustrates a perspective view of proximal end of the delivery system of Figure 1;

[0035] Figures 15A-15D illustrate perspective views of cord paths according to a preferred embodiment of the present invention;

5 **[0036]** Figure 16 illustrates side view of a delivery system according to the present invention;

[0037] Figure 17 illustrates a partially disassembled side view of the delivery system of Figure 16;

10 **[0038]** Figure 18 illustrates a partially disassembled perspective view of the delivery system of Figure 16;

[0039] Figure 19 illustrates a partially disassembled perspective view of the delivery system of Figure 16;

[0040] Figure 20 illustrates a side cross section view of a preferred embodiment of a delivery system according to the present invention;

15 **[0041]** Figure 21 illustrates a side cross section view of area 21 of Figure 20; and

[0042] Figure 22 illustrates a side view of a preferred embodiment of an axially compressible stability sheath according to the present invention.

20 **DETAILED DESCRIPTION OF THE INVENTION**

[0043] Figures 1-14 illustrate a preferred embodiment of a stent delivery system 100 according to the present invention which includes multiple mechanisms for retracting an outer tubular member 124 (also referred to as a jacket or sheath in this specification) to deliver a
25 prosthesis, such as a stent 160 in the current example. As seen in

- 9 -

Figure 1, the stent delivery system 100 includes a thumbwheel 106, a deployment lever 108, and a rapid deployment ring 110, each providing a different approach to retracting the outer tubular member 124 and therefore deploying the stent 160 or other prosthesis.

5 [0044] Each of the three deployment controls provides different actuation methods that facilitate deployment of the stent 160 at different speeds. For example, the thumbwheel 106 allows the user to slowly deploy the stent 160 with slow and precise thumb movement, while the rapid deployment ring 110 provides the user leverage to deploy the stent
10 160 in a more rapid fashion.

[0045] Additionally, some of the deployment controls can be configured to provide different ratios of retraction (e.g. 1 cm of movement of the deployment lever 108 moves the outer tubular member 124, 2 cm). Thus, some controls may provide "finer" retraction control
15 (i.e. smaller movement of the outer tubular member 124) and other controls may provide a "coarser" retraction control (i.e. larger movement of the outer tubular member 124).

[0046] In this respect, the delivery system 100 provides the user with a wider, more dynamic range of deployment controls for more precisely
20 delivering the stent 160 within a patient. Further, this range of deployment controls can better accommodate different types of stents or prostheses, especially those of almost any length.

[0047] The stent delivery system 100 generally includes two main portions: a stent delivery portion 104 and a handle portion 102. The
25 stent delivery portion 104 is the elongated catheter assembly which is inserted into the patient to deliver the stent 160 at a desired location. The handle portion 102 is connected to a proximal end of the stent

- 10 -

delivery portion 104, allowing the user to position the stent delivery portion 104 within the patient and release the stent 160.

[0048] As best seen in Figures 1 and 6-8, the stent delivery portion 104 includes an inner tubular member 128 preferably composed of a relatively stiff single material (e.g. polyimide) that preferably forms a single inner lumen. This allows the inner tubular member 128 to maintain some flexibility while retaining the strength to be pushed through the inner vessels of a patient.

[0049] With reference to Figure 7, the distal end of the inner tubular member 128 includes a reduced diameter region 127 between a distal dilator tip 126 (preferably composed of polyimide) and a shoulder 129. The reduced diameter region provides space to accommodate the stent 160 in an unexpanded position underneath the outer tubular member 124. The shoulder 129 and the distal dilator tip 126 prevent the stent from moving laterally on the inner tubular member 128, either proximally toward the handle portion 102 or distally out from under the outer tubular member 124. The delivery portion may also include pusher tubing that is disposed over the inner tubular member 128, proximal to a shoulder 129, which further supports the stent 160 when the outer tubular member 124 retracts during delivery. In this respect, the stent 160 maintains its position within the stent delivery system 100, providing a predictable delivery for the user.

[0050] As also seen in Figure 7, the distal end of the inner tubular member 128 also includes flushing holes 130, which are positioned underneath the stent 160 in the reduced diameter region 127 and which lead to, and are unitary with, a passage (not shown) within the inner tubular member 128, along its axis. This inner passage or lumen connects to a liquid source on the proximal end of the stent delivery

- 11 -

system 100 at luer adapter 118, allowing the user to flush out the stent 160 prior to delivery within the patient.

[0051] As best seen in Figure 6, the proximal end of the inner tubular member 128 comprises a rigid area 156 composed of less flexible materials, such as metals or hard plastics. This rigid area 156 is positioned within the handle portion 102, allowing the outer tubular member 124 to be easily retracted over the rigid area 156 without the inner tubular member 128 bending or creasing. The movement of the outer tubular member 124 over the inner tubular member 128 is discussed in greater detail below.

[0052] As previously mentioned, the outer tubular member 124 is positioned over the inner tubular member 128 and can be moved relative to the inner tubular member 128, particularly allowing the outer tubular member 124 to cover and uncover the unexpanded stent 160. Preferably, the outer tubular member 124 is composed of a braided polyimide. Alternately, the outer tubular member 124 is composed of a coextruded, trilayer construction. The inner layer is preferably polytetrafluoroethylene (PTFE), fluorinated ethylene propylene (FEP), high density polyethylene (HDPE), or urethane. The middle layer is a wire braid, and more preferably a 304V stainless steel flat wire braid of 1x3 (40 picks) construction, with wires having a 0.001 inch by 0.003 inch rectangular cross-section. Wires of other metals and alloys may also be used, including other stainless steel alloys, cobalt-chrome alloys, and other high-strength, high-stiffness, corrosion-resistant metal alloys. The outer layer is preferably a thermoplastic, melt processible, polyether-based polyamide, such as PEBAX®-7033 available from Modified Polymer Components, Inc. of Sunnyvale, CA. In the extrusion process, the inner and outer layers are bonded to each other and encapsulate the metallic reinforcing middle wire layer to create an integrated tubing. This tubing exhibits high lateral flexibility combined with a high degree of

- 12 -

longitudinal stiffness (resistance to shortening), and also high torqueability.

[0053] Referring to Figures 1, 6 and 8, stability sheath 122 and strain relief member 120 are connected to the handle portion 102 and are positioned over the outer tubular member 124. The strain relief member 120 (preferably composed of Polyurethane or Pebax® polyether block amides from Arkema) prevents sharp bends in the outer tubular member 124 near the handle portion 102, reducing stress or strain that may otherwise be introduced on connection points between the handle portion 102 and the outer tubular member 124. The stability sheath 122 extends along a portion of the length of the outer tubular member 124 to reduce any unintended movement of the stent delivery portion 104 while the outer tubular member 124 is being retracted (e.g. sideways or curling movement due to friction between the outer tubular member 124 and the inner tubular member 128).

[0054] As best seen in Figures 1-5, the handle portion 102 preferably includes three mechanisms for retracting the outer tubular member 124 relative to the inner tubular member 128. Specifically, the handle portion 102 includes the thumbwheel 106, the deployment lever 108, and the rapid deployment ring 110 that each are used to cause retraction of the outer tubular member 124 through different mechanisms within the handle portion 102.

[0055] Referring to Figure 2-5 the retraction mechanisms are built on an inner frame member 146 that is enclosed by body shell members 132A and 132B. As seen in Figures 2 and 11, the inner frame member 146 includes an elongated slot 146A that extends most of the length of the frame member 146. A slider 152, best seen in Figure 11-13, is positioned through and engaged with the slot 146A so as to slide along the length of the slot 146A. The slider 152 is also fixed to the proximal

- 13 -

end of the outer tubular member 124, preferably by an adhesive. Thus, as the slider 152 slides from a distal end of the slot 146A to a proximal end of the slot 146A, the outer tubular member 124 similarly moves over the rigid area 156 of the inner tubular member 128.

5 [0056] Optionally, a portion of the slider 152 contacts rack 140 to provide a tactile and audible "click" as the slider 152 slides proximally along the slot 146A. The teeth of the rack 140 also allow the slider 152 to move in only a proximal direction by including an angled distal surface and a perpendicular proximal surface. Thus, the contacting portion of
10 the slider 152 simply moves up and over the angled surface when moved proximally, but is stopped from movement by the perpendicular surface when distal movement is attempted. These "one way" teeth prevent the user from moving the outer tubular member 124 distally in an attempt to recapture a partially deployed stent 160.

15 [0057] The thumbwheel 106, deployment lever 108, and the rapid deployment ring 110 can each apply force in a proximal direction to the slider 152, causing the slider 152 and therefore the outer tubular member 124 to move in a proximal direction. As described in more detail below, each deployment control uses different mechanisms within
20 the handle portion 102 to create force on the slider 152. The distance the slider 152 moves will vary between each deployment control based, at least in part, on how the mechanisms of each deployment control are configured. These mechanisms and their possible configurations will become clear from the description below.

25 [0058] As seen best in Figures 2, 4, 9 and 10, the thumbwheel 106 provides proximal force on the slider 152 through use of a cord 180 wound on a spool 154 at one end and attached to the slider 152 at the other end. The cord 180 is either attached to or positioned around the slider 152 so that increased tension on the cord 180 provides a proximal

- 14 -

force on the slider 152, ultimately causing movement of the both the slider 152 and the outer tubular member 124.

[0059] Preferably the cord 180 is composed of a material that imparts little or no stretch to the length of the cord 180. For example, polyethylene, nylon, stainless steel wire, or braided stainless steel fibers. While a cord 180 is preferred in the present preferred embodiment, almost any flexible elongated member could be used, having different shapes, thicknesses, flexibilities and compositions. For example, a relatively flat ribbon shape may be used or alternately a cord having a generally square cross section. In another example, the cord can be composed of a single, continuous material such as all plastic, or multiple threads woven together.

[0060] Turning first to the rotation of the spool 154, a side of the inner frame member 146 includes an axle 155 onto which the spool 154 and the thumbwheel 106 rotatably mount by way of apertures through their respective centers. When the handle portion 102 is fully assembled, the spool 154 is positioned within the thumbwheel 106, pressing against a side of thumbwheel 106.

[0061] As best seen in Figures 9 and 10, the thumbwheel 106 engages the spool 154 with a "one way" engagement mechanism that allows the thumbwheel 106 to only engage and rotate the spool 154 in one direction. In this respect, the user is limited to retracting the outer tubular member 124 only, preventing attempts to recapture a partially deployed stent 160.

[0062] The engagement mechanism includes raised members 106A, seen best in Figure 10, positioned in a circular pattern on the inner surface of the thumbwheel 106. Each raised member 106A includes a flat surface 106B perpendicular to the inner surface of the thumbwheel

- 15 -

106 and an angled surface 106C. The angled surface 106C of one raised member 106A is positioned near the flat surface 106B of another raised member 106A, orienting all of the surfaces in a single direction (e.g. all angled surfaces 106C face a clockwise direction while all flat surfaces 106B face a counter clockwise direction).

[0063] The spool 154 includes two floating arms 154A having an outwardly extending region 154B, positioned to have a similar circumferential position as raised members 106A. When the handle portion 102 is assembled, the extending region 154B contacts either the raised members 106A or the space in between the raised members 106A, depending on the rotational orientation of the thumbwheel 106. As the thumbwheel 106 is rotated in one direction, the flat sides 106B of the raised members 106A contact the extending region 154B, causing the spool 154 to rotate and therefore wind up the cord 180.

[0064] However, if the thumbwheel 106 is rotated in the opposite direction, the angled surface 106 contacts the extending region 154B, causing the floating arm 154A to move towards the inner frame member 146. As the thumbwheel 106 continues to rotate, the extending region 154B passes over the top of raised member 106A until the end of the raised member 106A is reached, at which time the floating arm 154A snaps back to its original position. Thus, the thumbwheel 106 rotates, but the spool 154 is not engaged and therefore does not rotate, effectively limiting rotation of the spool 154 by the thumbwheel 106 to only one direction.

[0065] As previously described, rotation of the spool 154 winds one end of the cord 180, reducing the effective length of the cord 180 in the handle portion 102. However, the cord 180 must also be appropriately positioned within the handle portion 102 to create a proximal force on the slider 152. This cord position or cord path can be more clearly

- 16 -

observed by comparing the exploded view of Figure 2 with the cord 180 shown in Figure 15A. As seen in these figures, one end of the cord 180 is wrapped around the spool 154, passing around stationary anchor member 150 that is fixed to the inner frame member 146, through a
5 passage 108A of the movable deployment lever 108, back around a stationary anchor 149 that is also fixed on the inner frame member 146, then passing down along the side of inner frame member 146, around anchor member 148 at the proximal end of the inner frame member 146 and extending back towards the distal end of the inner frame member
10 146, and finally terminating with a knot around slider 152. Each of the stationary anchors has curved surfaces upon which the cord 180 can easily travel. Thus, as the spool 154 rotates in one direction (depending which direction the spool 154 is configured to wind the cord 180), the cord 180 pulls the slider 152 towards the proximal end of the handle
15 portion 102.

[0066] The mechanisms of the deployment controls, as previously mentioned, can be configured to change the retraction ratio of the outer tubular member 124. In one example, the mechanisms of the thumbwheel 106 can be modified by changing the size of the spool 154.
20 More specifically, the size of the spool 154 (i.e. the spool diameter) can be increased or decreased to change the amount of cord 180 each rotation of the thumbwheel 106 takes up. For example, decreasing the size of the spool 154 will reduce the amount of cord 180 taken up by each rotation of the thumbwheel 106 and therefore reduces the amount
25 the outer tubular member 124 is retracted. Similarly, increasing the size of the spool 154 will increase the amount of cord 180 taken up by each rotation of the thumbwheel 106, increasing the amount the outer tubular member 124 is retracted.

[0067] Turning to the second deployment control, the deployment
30 lever 108, can also retract the slider 152 and therefore the outer tubular

- 17 -

member 124 by increasing tension on the cord 180 and therefore on the slider 152 as well. As seen in Figures 1-5, the deployment lever 108 engages a top portion of the inner frame member 146 over a rack 144, sliding in a proximal direction along the top portion of the inner frame member 146. As the deployment lever 108 moves in a proximal direction, it increases the path the cord 180 takes to reach the slider 152, increasing the tension on the cord 180 and generating a proximal force on the slider 152.

[0068] Like the thumbwheel 106 and the slider 152, the deployment lever 108 only moves in one direction, allowing the user to only retract the outer tubular member 124. This "one way" movement is preferably achieved with a direction arm 108B (Figure 3) extending from a proximal end of the underside of the deployment lever 108. This direction arm 108B includes an end portion that engages the teeth of a rack 144. As seen best in Figure 3, the teeth of the rack 144 have a distal surface that is angled and a proximal surface that is generally perpendicular to the inner frame member 146. When the deployment lever 108 is moved in a proximal direction, the direction arm 108B follows the angled distal surface upward, moving over and past each tooth. However, when the deployment lever 108 is moved in a distal direction, the end of direction arm 108B moves against the perpendicular proximal surface of the tooth. Since the proximal surface is not angled beyond 90 degrees (i.e. beyond the perpendicular) the direction arm 108B is unable to move over the tooth. Thus, the direction arm 108B prevents the deployment lever 108 from moving in a distal direction, to recapture the stent 160. Additionally, the position of the deployment lever 108 is maintained when the user rotates the thumbwheel 106, which may create a distal force on the lever 108 as the tension on the cord 180 is increased.

[0069] Referring to Figures 2-5, the proximal movement of the deployment lever 108 moves the slider 152 by effectively increasing the

- 18 -

length of the path that the cord 180 must take to reach the slider 152. As previously mentioned, the cord 180 passes through the passage 108A of the movable deployment lever 108, around the stationary anchor member 149 that is fixed on the inner frame member 146, down
5 the length of the inner frame member 146, then around stationary anchor member 148 at the proximal end of inner frame member 146. As the deployment lever 108 is moved in a proximal direction, the passage 108A on the deployment lever 108 moves away from the anchor member 149 that is fixed on the inner frame member 146. As a result,
10 the distance between the passage 108A and the anchor member 149 increases, creating a longer path for the cord 180. Since one end of the cord 180 is fixed around the spool 154, the movement of the deployment lever 108 in this manner causes the slider 152 and therefore the outer tubular member 124 to move proximally. In this respect, the one-way,
15 proximal movement of the deployment lever 108 can retract the outer tubular member 124 to deploy the stent 160 within the patient.

[0070] The rapid deployment ring 110 provides yet another method of retracting the outer tubular member 124 within the handle portion 102. As seen best in Figures 2-6, 11 and 13, the rapid deployment ring 110 is
20 a pull tab having an elongated body and a sliding portion 110A shaped to slidably couple to the outer tubular member 124, distal to the slider 152. The sliding portion 110A preferably has an aperture that allows it to not only be positioned onto the diameter of the outer tubular member 124, but also freely slide along its length.

25 **[0071]** As shown in Figures 11 and 13, when the rapid deployment ring 110 is pulled by the user in a proximal direction, the sliding portion 110A pushes on a distal side of the slider 152 in a proximal direction also, moving the slider 152 proximally and causing the outer tubular member 124 to retract. Since the rapid deployment ring 110 via its
30 sliding portion 110A applies direct force on the slider 152 without any

- 19 -

intervening mechanisms (i.e. in a 1:1 retraction ratio), the user is free to retract the outer tubular member 124 at any speed they desire. This arrangement especially facilitates quick retraction of the outer tubular member 124 that would otherwise be difficult using the thumbwheel 106
5 or deployment lever 108.

[0072] Referring to Figures 1 and 2, the ring portion of the rapid deployment ring 110 is positioned through a slot 114 in shell member 132A and stores on a raised column 112. The raised column 112 has a diameter about the same size as the diameter of the aperture of the
10 rapid deployment ring 110, allowing the ring 110 to lock on to the raised column 112. Optionally, the raised column 112 may also include an "imprint" or depression around the raised column 112 which is the size and shape of the ring portion of the rapid deployment ring 110 and which allows the ring portion to sit within the depression without falling out.
15 Thus, the rapid deployment ring 110 can be kept out of the way if the user decides to deploy the stent 160 with the thumbwheel 106 or deployment lever 108. Further, since the sliding portion 110A can freely slide along the outer tubular member 124 (i.e. is not fixed or adhered in place on the member 124), use of the thumbwheel 106 or deployment
20 lever 108 will not cause the rapid deployment ring 110 to come loose from the raised column 112 and move down the slot 144. In other words, the position of the rapid deployment ring 110 is not affected when other deployment controls are actuated by the user.

[0073] Preferably, as seen in Figures 11-13, the sliding portion 110A
25 has a thin, side profile to allow a finger member 116A of a locking clip 116 to be positioned over both the sliding portion 110A and the slider 152. Since the slider 152 has horizontally raised portions around both a proximal and a distal side of the finger 116A of the locking clip 116, the slider 152 moves against this finger 116A and is prevented from lateral
30 movement. In this respect, the finger 116A of the locking clip 116 acts

- 20 -

as a locking pin that prevents the stent 160 from accidentally being deployed during shipment or prior to insertion within a patient.

[0074] The retraction ratio for both the deployment lever 108 and the thumbwheel 106 can be further adjusted by changing the path of the cord 180 within the handle portion 102. One preferred method of changing this ratio is to distribute the user's retraction force over an increased number of anchors (e.g. anchor members 148 or 149). In this respect, the anchor members and cord 180 act similar to a rope and pulley system where additional anchors function as additional pulleys. Like a pulley system, the more anchors the cord 180 is positioned around, the less the outer tubular member 124 will move relative to either the thumbwheel 106 or deployment lever 108 (and the easier it will be to move the thumbwheel 106 or deployment lever 108).

[0075] A more specific example of this concept can be seen in Figure 15B in which the cord 180B is positioned in a configuration generally similar to that of Figure 15A. However, instead of terminating the cord 180B at the slider 152, as seen in Figures 2-5, the cord 180 passes around the slider 152 and terminates at a rear anchor 151, as shown in Figure 14 at the proximal end of inner frame member 146. In this respect, the thumbwheel 106 or deployment lever 108 moves the outer tubular member 124 a smaller amount relative to the configuration shown in Figure 15A because of the pulley effect previously described.

[0076] Yet another specific example can be seen in Figure 15C, which can be compared with the structures seen in Figures 2-5. In this example, one end of cord 180C is wrapped around the spool 154 as previously described, passing around a stationary anchor member 150 located on a top region of inner frame member 146, through passage 108A of the movable deployment lever 108, back around anchor member 148, forward around slider 152, back around anchor member

- 21 -

151, and finally tying through aperture 153 which is located on a distal portion of the inner frame member 146. Similarly, the thumbwheel 106 or deployment lever 108 move the outer tubular member 124 a smaller amount relative to the configurations shown in Figures 15A and 15B due to the previously described pulley effect.

5
10
15
20
25

[0077] Figure 15D illustrates another example path of cord 180D which passes around fewer anchor members and therefore provides a ratio of user input to outer tubular member 124 movement close to 1:1. For comparison, Figure 15D can be compared with Figures 2-5 to appreciate the path of the cord 180D. One end of the cord 180D is wrapped around the spool 154, then passes around stationary anchor member 150, through aperture 108A of the movable deployment lever 108, down around slider 152, then back to rear anchor 156 (seen best in Figure 14).

[0078] The path of the cord 180 may be configured in a variety of other arrangements according to the present invention to achieve a desired retraction ratio. Typically, a retraction ratio that provides a slower retraction (e.g. 2 cm of deployment lever 106 movement to 1 cm of outer tubular member 124 movement) may be preferred for smaller stents (e.g. 20-90 mm), while a retraction ration that provides a quicker retraction (e.g. 1 cm of movement of deployment lever 108 to 1 cm of movement of outer tubular member 124) may be preferred for larger stents (e.g. 90-170 mm). However, it should be understood that most ratios can be used for any commonly used stents lengths, leaving the ratio as a matter of preference for the user.

[0079] While both the thumbwheel 106 and the deployment lever 106 act on the cord 180 to retract the slider 152, it should be appreciated that these two mechanisms act independently of each other and therefore do not affect the relative performance of the other. In other words, if the

- 22 -

user switches between these two deployment controls, there will not be a "lag" as slack in the cord 180 is taken up by the second control. Instead, actuation of either deployment control maintains tension on the cord 180 so that movement of either deployment control will immediately
5 move the slider 152. For example, if the deployment lever 108 is initially moved, the cord 180 maintains tension so that subsequent rotation of the thumbwheel 106 causes immediate movement of the slider 152.

[0080] By contrast, if the user initially pulls the rapid deployment ring 110, slack may be created in the cord 180. If either the thumbwheel 106
10 or the deployment lever 108 is then moved, that slack in the cord 180 will first be taken up by their movement, causing a delay in the retraction of the outer tubular member 124 until tension in the cord 180 increases. If a user, who cannot see these inner mechanisms or slack in the cord 180, is not expecting this delay, they may mistakenly think that the
15 delivery system 100 is broken or has finished deploying the stent 160. Thus, the independent arrangement of the thumbwheel 106 and the deployment lever 108 provide a more consistent and predictable deployment procedure.

[0081] In operation, the inner tubular member 128 is fed over a
20 guidewire and guided to a target location within the patient. Typically, radiopaque markers within the distal end of the delivery system 100 are viewed fluoroscopically to confirm that the inner tubular member 128 has achieved the desired location within the patient.

[0082] Once the user is satisfied that the delivery system 100 is in a
25 desired position, the user actuates one of the three deployment controls. Typically, the outer tubular member 124 is retracted slowly at first, allowing the distal end of the stent 160 to expand or "flower" against the target tissue of the patient. While the user can initially retract the outer tubular member 124 with any of the three delivery controls, the

- 23 -

thumbwheel 106 and the deployment lever 108 may allow for a slower and more controlled retraction since either can be controlled with only the user's thumb.

[0083] If the user desires to maintain a slow and highly controlled
5 retraction of the outer tubular member 124, the thumbwheel 106 or
deployment lever 108 use may be continued until the stent 160 has been
completely uncovered and expanded against the target area. However,
if the user desires to quickly retract the portion of the outer tubular
10 member 124 that remains over the stent 160, the rapid deployment ring
110 can instead be used for more rapid retraction. The user simply pulls
the rapid deployment ring 110 along slot 114 until the stent 160 has
been fully deployed. Once the stent 160 has been fully deployed, the
delivery device 100 is retracted from the patient, completing the delivery
procedure.

15 **[0084]** It should be appreciated that any of the three deployment
controls can be used by the user, alone or in various combinations, to
retract the outer tubular member 124 and deliver the stent 160. While
the use of the deployment controls may rest largely with the preference
of the user, other factors may contribute to such a selection. For
20 example, shorter stents (e.g. 20-90 mm) may be deployed more
effectively with the precision of the thumbwheel 106 or deployment lever
108 while longer stents (e.g. 100-170 mm) may be more effectively
deployed with a combination of the thumbwheel 106 initially and the
rapid deployment ring 110 subsequently.

25 **[0085]** Figures 16-19 illustrate another preferred embodiment of a
stent delivery system 200 according to the present invention. The stent
delivery system 200 is similar to the previously discussed stent delivery
system 100, but lacks the deployment lever 108, providing the user with

- 24 -

only the thumbwheel 106 and rapid deployment ring 110 to retract the outer tubular member 124.

[0086] The stent delivery system 200 utilizes the same inner frame member 146 and body shell members 132A and 132B by including a cover plate 210 which is positioned over the rack 144 and over the sides of the inner frame member 146. The cover plate 210 blocks the aperture created by the body shell members 132A and 132B where the deployment lever 108 is positioned in the previously described delivery system 100.

[0087] Additionally, referring to Figures 17-19, the cover plate 210 includes an aperture 212 through which the cord 180 may be positioned. Since the deployment lever 108 is not present in this preferred embodiment, the aperture 212 provides a passage similar to passage 108A of the deployment lever 108. This aperture 212 allows the handle portion 202 to provide similar cord path configurations as those shown in Figures 11A-11D.

[0088] As best seen in Figures 17 and 18, the stent delivery system 200 also includes support blocks 214 that are attached to the inner frame member 146. The support blocks 214 form an aperture with the side of the inner frame member 146 which is positioned around rigid area 156 of the inner tubular member 128. The additional support provided to the rigid area 156 further reduces the likelihood that the rigid area 156 will bend or fold during retraction of the outer tubular member 124. This bending or folding can result from friction between the inner tubular member 128 and outer tubular member 124 during retraction of the slider 152. Additionally, these support blocks 214 can act as stops for the slider 152, preventing the outer tubular member 124 from being retracted any further.

- 25 -

[0089] It should be understood that different elements, assemblies, or aspects of each embodiment can be removed from, added to, or combined with other embodiments. For example, the support blocks 214 can be used with the stent delivery system 100. In another
5 example, the preferred embodiment of Figure 1 can include only the thumbwheel 106 and deployment lever 108, leaving off the rapid deployment ring 110. (This means that the deployment lever 108 may be moved into the area otherwise occupied by the rapid deployment ring. Additionally, a cover, similar to cover plate 210 can be used to
10 cover an open area, allow the manufacture to use similar parts (e.g. similar outer body member 132A and 132B for each design).

[0090] While the stent delivery systems 100 and 200 have been primarily described as delivering stents, these embodiments may be modified to deliver other prosthesis devices that can be delivered within
15 a retractable outer tubular member 124.

[0091] In some situations, a stent or other device must be delivered within a patient through a convoluted delivery path. As the path of the delivery device becomes more tortuous, the delivery device itself may become contorted. In such situations, the ability of the stability sheath
20 122 to transmit torque generated at the handle portion 102 may be reduced. In other words, a proximal end of the stability sheath 122 may twist without resulting in the same degree of twist to the distal end. In one example, the user attempts to rotate the handle portion 102 but the stability sheath 122 tends to "corkscrew" or twist and cause compression
25 on the outer tubular member 124. In some circumstances, such a compression force can inhibit the outer tubular member 124 from retracting and therefore complicate stent deployment. In a worst case, such compression may result in tearing or other breakage of the delivery system, causing further complications.

- 26 -

[0092] Figures 20 and 21 illustrate another preferred embodiment of a stent delivery system 300 according to the present invention that seeks to eliminate the possibility of twisting by the stability sheath 122. Generally, the stent delivery system 300 is similar to the previously described delivery systems of this specification except that the stability sheath 122 is configured for rotation relative to the other elements of the system 300, and particularly relative to the handle 102 and outer tubular member 124. As a result, rotation of the handle portion 102 of the delivery system 300 can occur without requiring rotation of the stability sheath 122.

[0093] As seen best in Figure 21, this rotational capability of the stability sheath 122 is preferably achieved by providing a circular disc member 304 near the proximal end of the stability sheath 122. This disc member 304 is positioned within a circular cavity 302A within a distal end 302 of the inner frame member 146. The circular cavity 302A is preferably slightly larger than the disc member 304 to allow for rotation of both the disc member 304 and the stability sheath 122 but not so large as to introduce an undesirable amount of "play" in which the disc member can move. The disc member 304 is preferably bonded to the stability sheath 122 or can alternately be integrally formed with the stability sheath 122. In this respect, the disc member 304 retains the axial position of the stability sheath 122 on the delivery device 300 while also allowing free rotation of the stability sheath 122.

[0094] Since the above-described configuration results in the independent rotation of the stability sheath 122 relative to the delivery system 300, it is desirable to minimize friction between the strain relief member 120 and the stability sheath 122. In this regard, a low friction coating may be applied to the inner passage of the strain relief member 120 and the outer surface of the stability sheath 122. Alternately, a lubricant may be introduced between these surfaces. Friction is also

- 27 -

preferably minimized between the inner surface of the stability sheath 122 and the outer surface of the outer tubular member 124. This further facilitates independent rotation of the stability sheath 122.

[0095] In operation, the user advances the delivery portion 104 of the
5 delivery device 300 into the patient and rotates the handle portion 102 to
achieve a desired orientation of the delivery portion 104. As with
previously described embodiments, the handle portion 102 and the
delivery portion 104 are fixed relative to one another and thus rotation of
10 the handle portion 102 will result in corresponding rotation of the delivery
portion 104. However, due to the use of the circular disc member 304
described above, the stability sheath 122 is not forced to rotate along
with the delivery portion 104 or handle portion 102. As a result the
stability sheath 122 does not inadvertently inhibit (e.g., through
15 compression, friction, etc.) the movement of the delivery portion 104
within the patient. Therefore complications during a delivery procedure
are minimized.

[0096] Figure 22 illustrates another preferred embodiment of a stent
delivery system according to the present invention which seeks to
reduce complications resulting from twisting by the stability sheath 340.
20 While the preferred embodiment illustrated in Figures 20 and 21 seeks
to prevent twisting, the present embodiment compensates for the effects
of twisting by providing a region on the stability sheath 340 that
compresses in length. This allows for a proximal end of the stability
sheath 340 to remain secured to the handle portion 102 while allowing a
25 distal end of the stability sheath 340 to axially retract along with the outer
tubular member 124 if the two are frictionally engaged with one another.

[0097] The stability sheath 340 includes a plurality of circumferential
crumple zones 342 located along a length of the sheath 340. Preferably,
these crumple zones 342 are located near the proximal end of the

- 28 -

sheath 340, just distal to the strain relief member 120. Each crumple zone 342 is configured to compress under axial pressure similar to an "accordion" region of a bendable straw. Therefore, if the stability sheath 340 becomes twisted and thereby frictionally engages the outer tubular member 124, the crumple zones 342 will compress in length when the user retracts the outer tubular member 124 (i.e., when the user retracts the outer tubular member 124 to deploy the stent or other prosthesis). In this respect, the crumple zones 342 allow the distal end of the stability sheath 340 to move with the outer tubular member 124 instead of otherwise preventing retraction.

[0098] Preferably, the crumple zones 342 allow a length of axial compression at least equal to the length of the prosthesis to be deployed. In other words, if the stability sheath 340 does bear down on the outer tubular member 124, the crumple zones 342 will allow the stability sheath 340 to move with the outer tubular member 124 until the prosthesis has been delivered.

[0099] Preferably, each of the crumple zones 342 compress in length by folding or buckling, similar to an accordion. In one example, this folding can be achieved by decreasing the thickness of each crumple zone 342 relative to the thickness of the surrounding portions of the stability sheath 340. When axial force is applied to the stability sheath 340 (i.e. by retraction of the outer tubular member 124), the weaker areas of the crumple zones 342 buckle, decreasing the overall length of the stability sheath 340.

[00100] Crumple zones 342 with decreased thicknesses can be created with various techniques known in the art. For example, the zones 342 can be formed as a unitary part of the stability sheath 340. Alternately, areas of decreased thicknesses can be cut out or otherwise removed with laser or mechanical cutting tools. In another example, the

- 29 -

areas of decreased thickness can be created by adding additional layers of material around each crumple zone 342.

[00101] In another preferred embodiment, each of the crumple zones 342 can be created by introducing circumferential accordion-like creases along the stability sheath 340 (i.e. creases oriented inward and outward of the sheath 340 similar to a creased region of a bendable straw). In yet another preferred embodiment, the crumple zones 342 can be created with perforations or small punctures to weaken the stability sheath 340 and promote buckling.

[00102] In operation, the user advances the delivery portion 104 of the delivery device into the patient and rotates the handle portion 102 to achieve a desired orientation of the delivery portion 104. As with previously described embodiments, the handle portion 102 and the delivery portion 104 are fixed relative to one another and thus rotation of the handle portion 102 will result in corresponding rotation of the delivery portion 104. If such rotation results in the twisting of the stability sheath 340 on the outer tubular member 124, the crumple zones 342 will compress in length as the outer tubular member is retracted. As a result the stability sheath 340 does not inadvertently inhibit (e.g., through compression, friction, etc.) the movement of the delivery portion 104 within the patient. Therefore complications during a delivery procedure are minimized.

[00103] Another preferred embodiment according to the present invention seeks to eliminate twisting of the stability sheath 122 with a breakaway bond between the stability sheath 122 and the handle portion 102. Preferably, the sheath 122 and the handle portion 102 can be arranged similarly to the embodiments of Figures 1-19. However, a reduced amount of bonding material can be used to fix the stability sheath 122 to the frame member 146, allowing the stability sheath 122

- 30 -

to break free under pressure and move with the outer tubular member 124. The user can adjust the amount of "breakaway force" needed to break the stability sheath 340 free by varying the amount and type of adhesive or bonding agent.

5 [00104] As the user rotates the handle portion 102 during a delivery procedure the proximal end of the stability sheath 122 may twist relative to the distal end, creating force on the bond between the stability sheath 122 and the handle portion 102. As the force on the bond reaches a predetermined amount, it breaks, allowing the sheath 122 to either
10 untwist under its own force or remain twisted and therefore move with the outer tubular member 124. In either scenario, the stability sheath 122 is prevented from inhibiting the movement of the outer tubular member 124 and therefore delivery of the prosthesis.

[00105] Although the invention has been described in terms of
15 particular embodiments and applications, one of ordinary skill in the art, in light of this teaching, can generate additional embodiments and modifications without departing from the spirit of or exceeding the scope of the claimed invention. Accordingly, it is to be understood that the drawings and descriptions herein are proffered by way of example to
20 facilitate comprehension of the invention and should not be construed to limit the scope thereof.

What is claimed is:

1. A stent delivery system, comprising:

a first tubular member having a distal end sized and shaped to receive a stent;

a second tubular member longitudinally slidable over said first tubular member;

a third tubular member at least partially disposed over said second tubular member,

said third tubular member rotatable relative to said first tubular member and to

said second tubular member, a disc member provided near the proximal end of

the third tubular member; and

a handle body defining a cavity in which the disc member of said third tubular member

is positioned to permit free rotation of the third tubular member relative to the

handle body and said second tubular member when in use for stent delivery,

the handle body coupled to said second tubular member to retract said second

tubular member relative to said first tubular member.

2. The system of claim 1, the disc member being a circular disc member and the cavity being a circular cavity.

3. The system of claim 1, wherein the disc member is bonded to the third tubular member.

4. The system of claim 1, wherein the disc member is integrally formed with the third tubular member.

5. The system of claim 1, further comprising a strain relief member at least partially disposed over the third tubular member.

6. The system of claim 5, wherein the inner surface of the strain relief member includes a low friction coating.

7. The system of claim 6, wherein the outer surface of the third tubular member includes a low friction coating.

8. The system of claim 5, further comprising a lubricant disposed between the inner surface of the strain relief member and the outer surface of the third tubular member.

9. The system of claim 1, wherein the handle body is configured to retract said second tubular member relative to said first tubular member to uncover and deploy the stent.

10. The system of claim 1, wherein the handle body includes multiple controls for retracting said second tubular member relative to said first tubular member, each of the multiple controls configured to provide the user with a different retraction ratio.

11. The system of claim 10, wherein the multiple controls include at least three different controls for retracting said second tubular member relative to said first tubular member, each of the at least three different controls configured to provide the user with a different retraction ratio.

1/24

Fig. 1

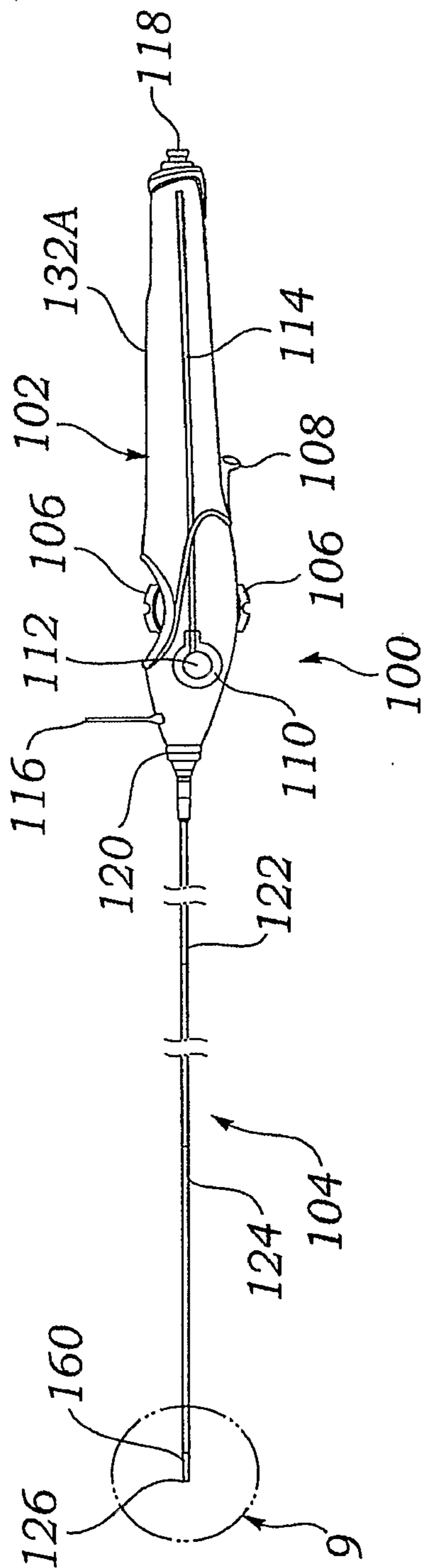

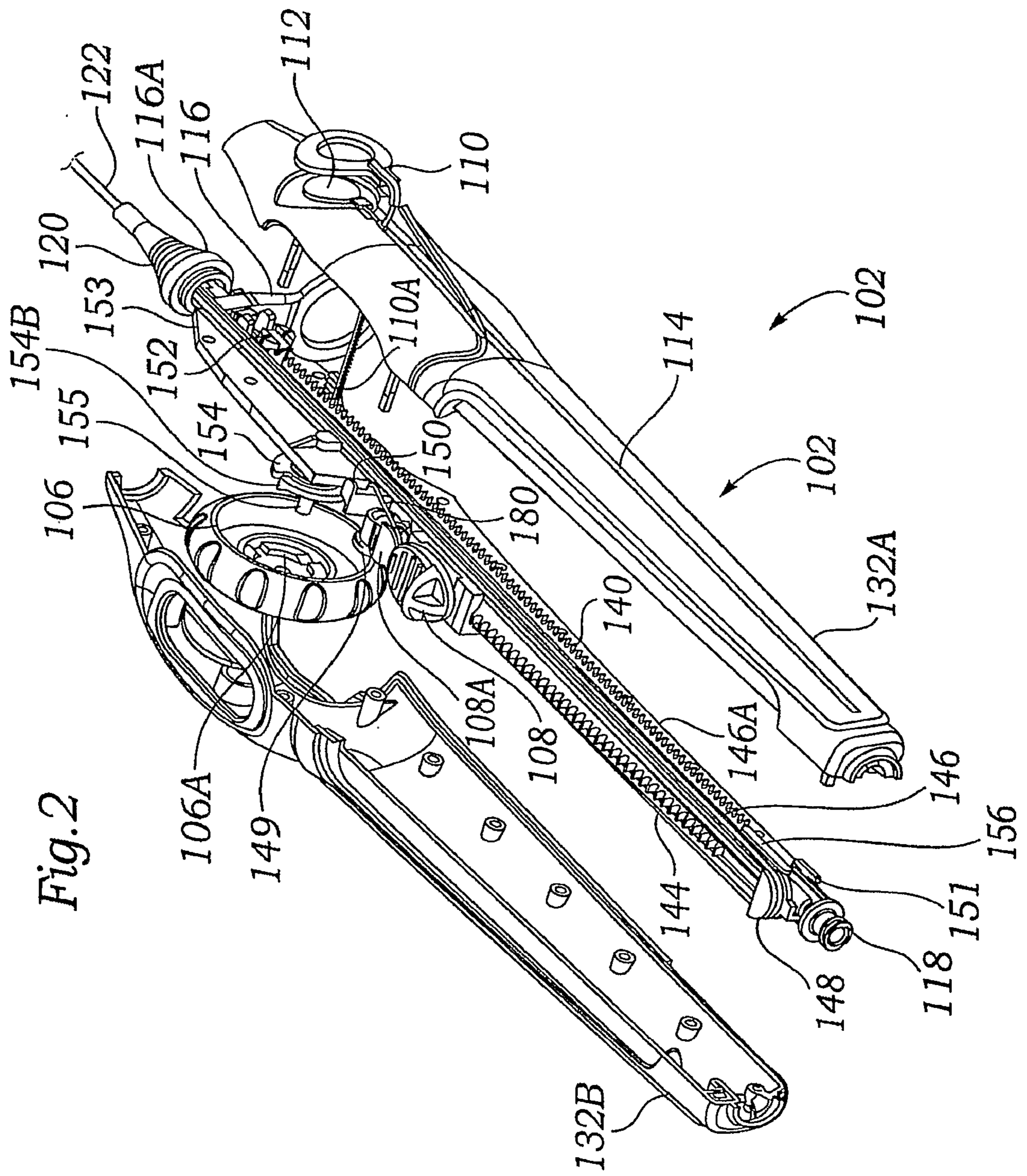
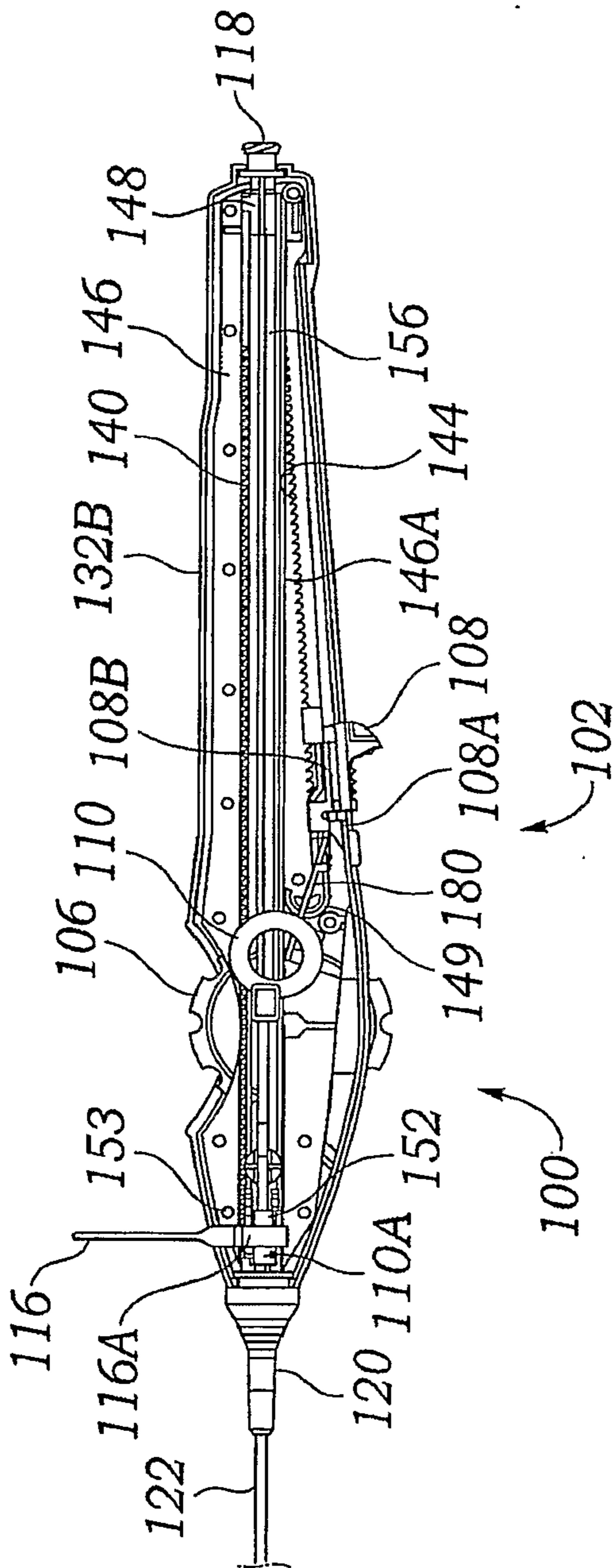
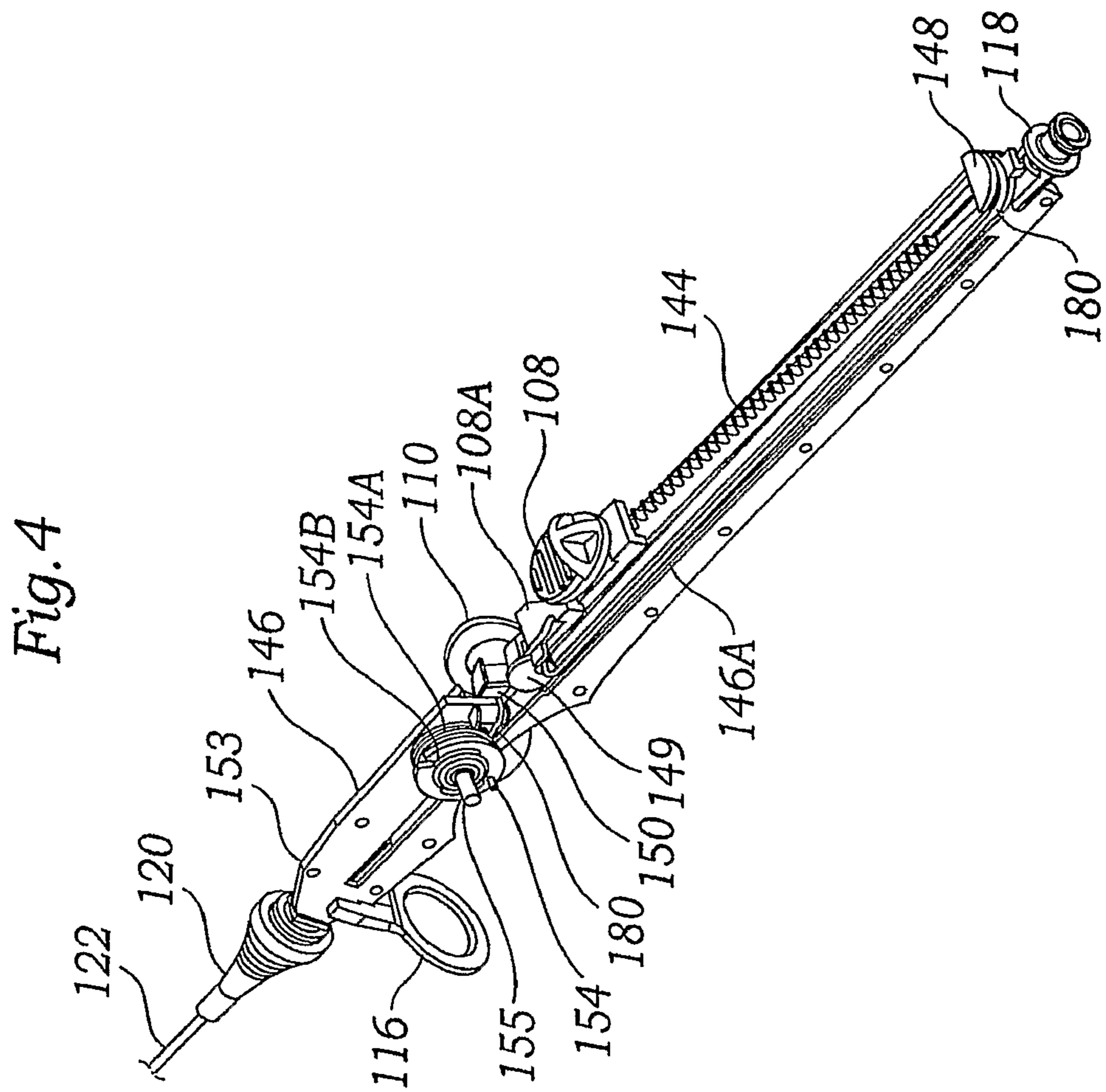

Fig. 2

Fig. 3





5/24

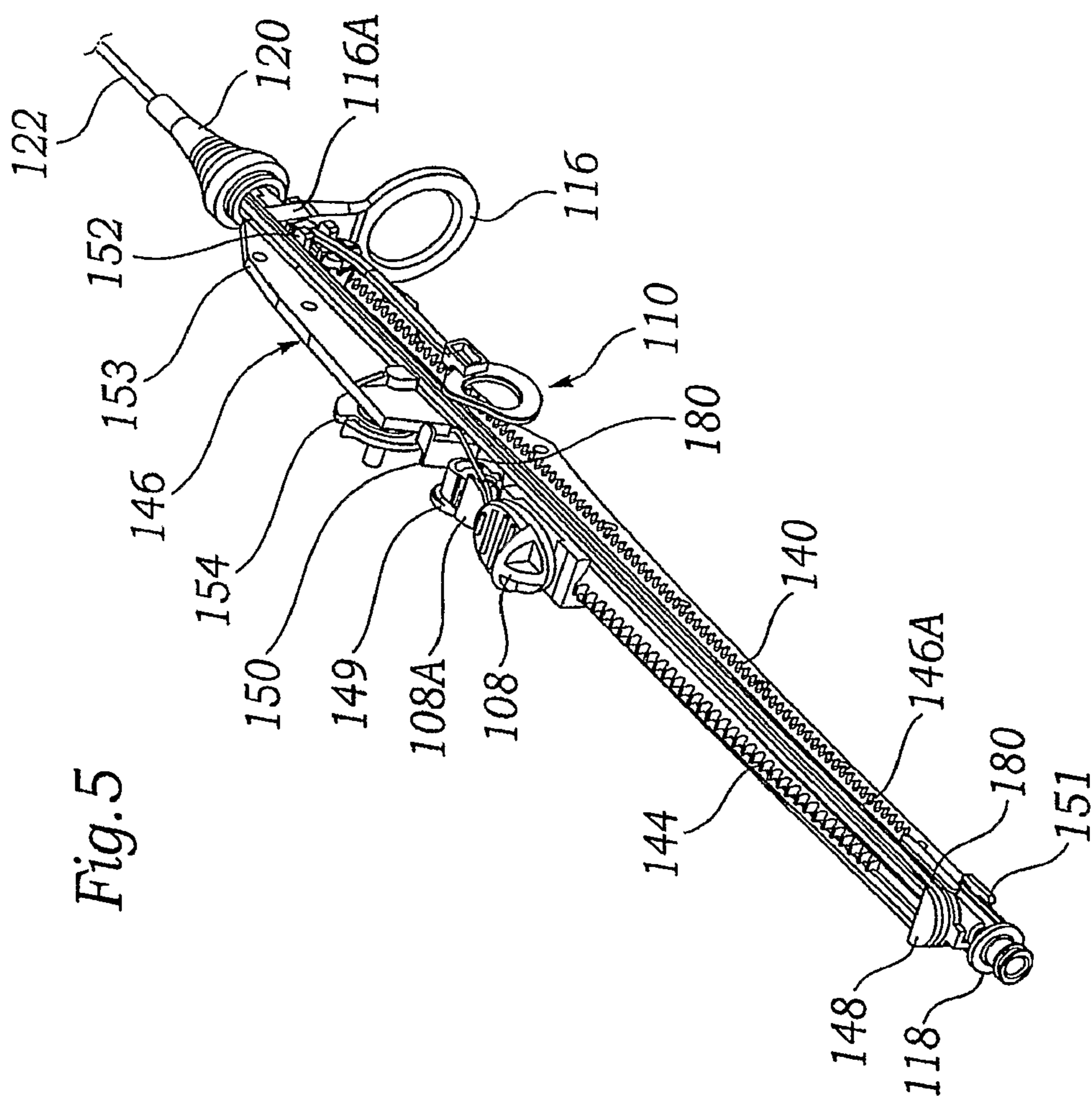

Fig. 5

6/24

Fig. 6

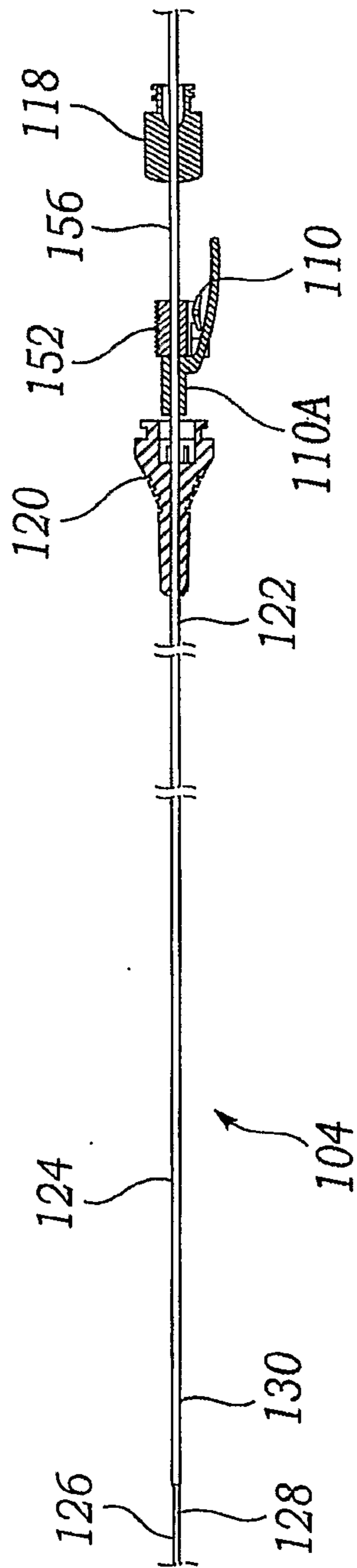
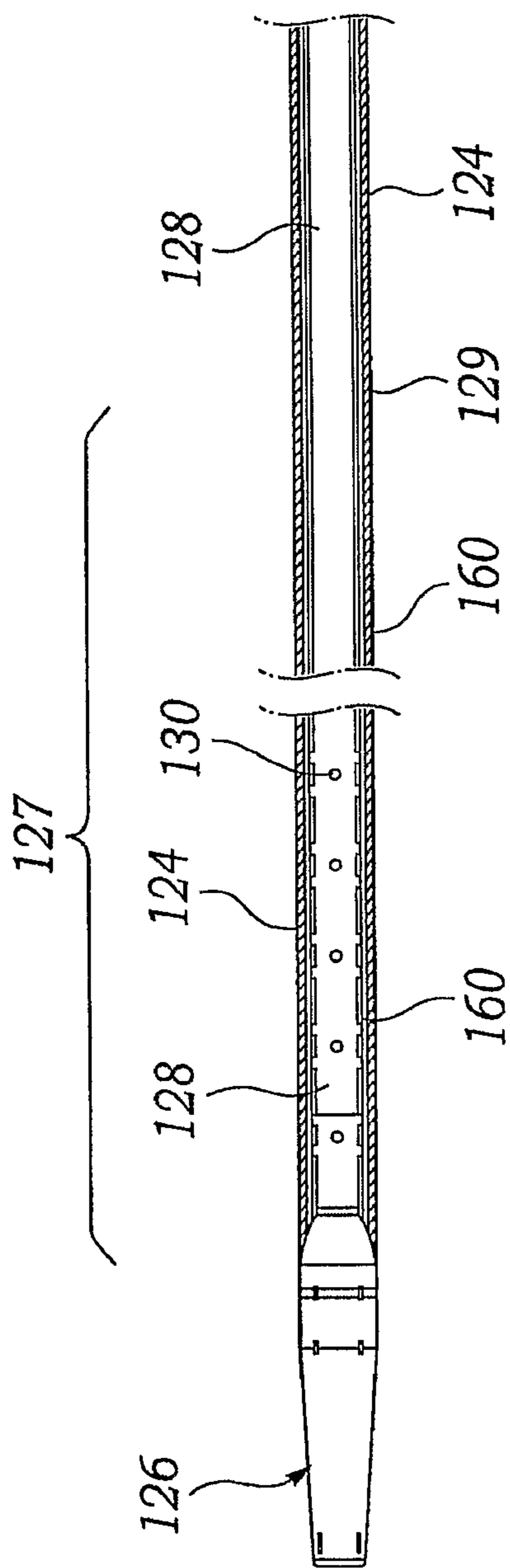

Fig. 7



7/24

8/24

Fig. 8

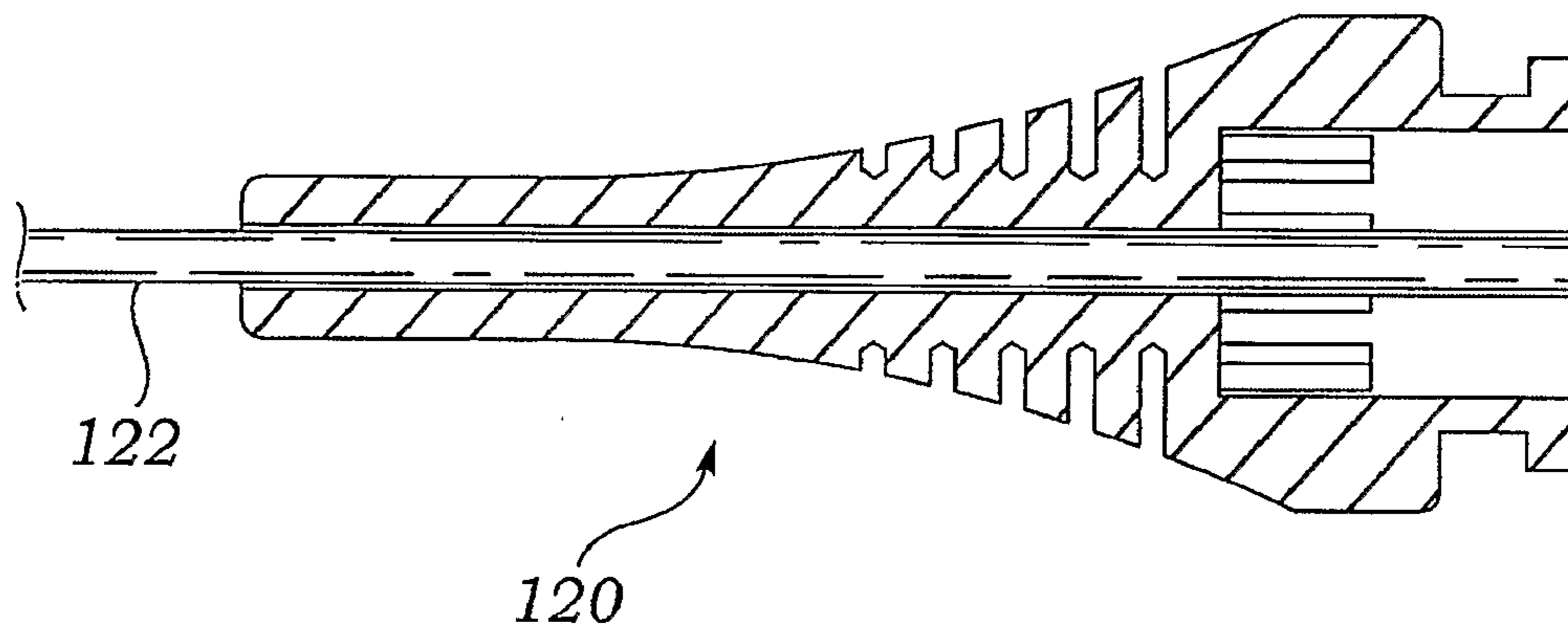

9/24

Fig. 9

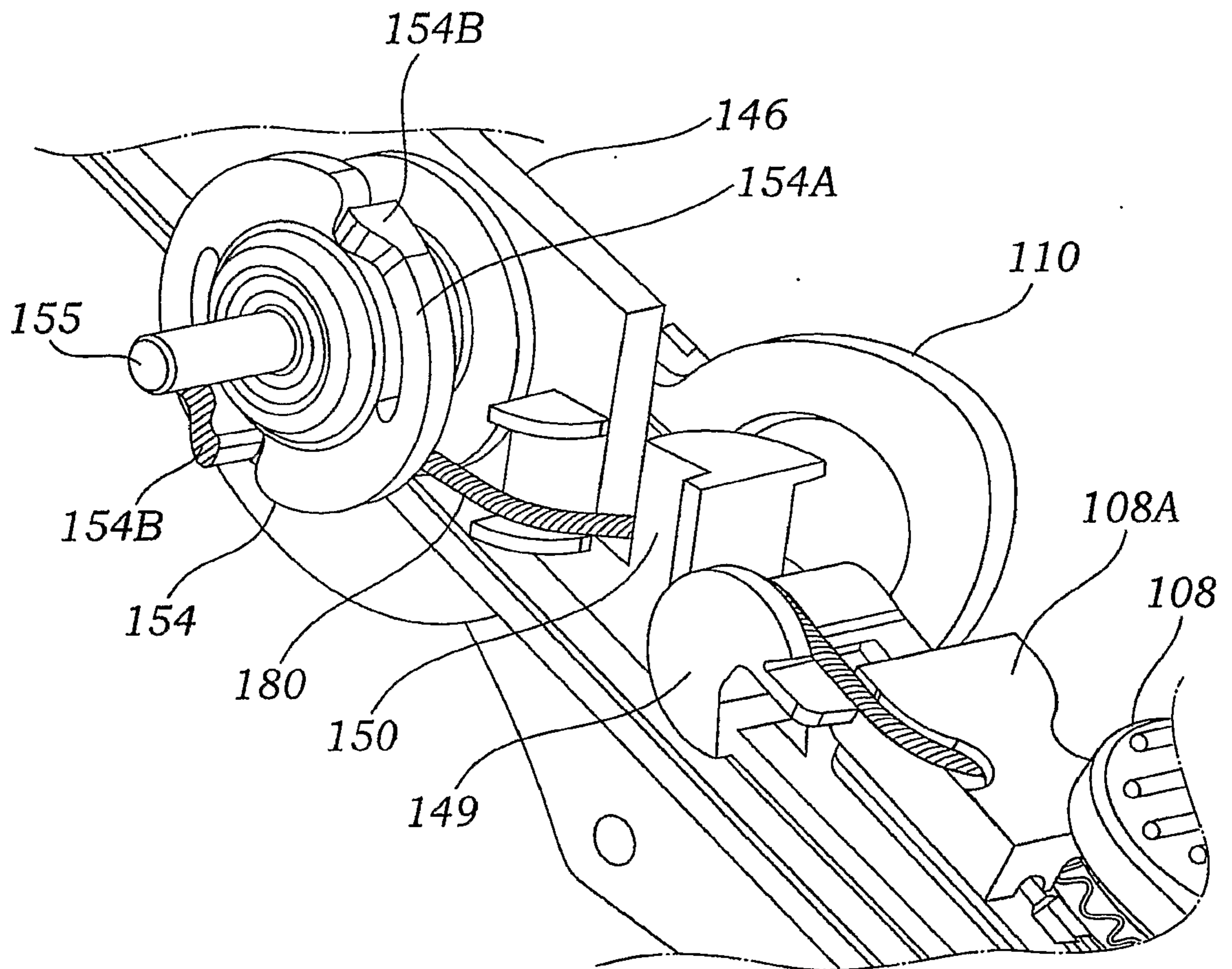

10/24

Fig. 10

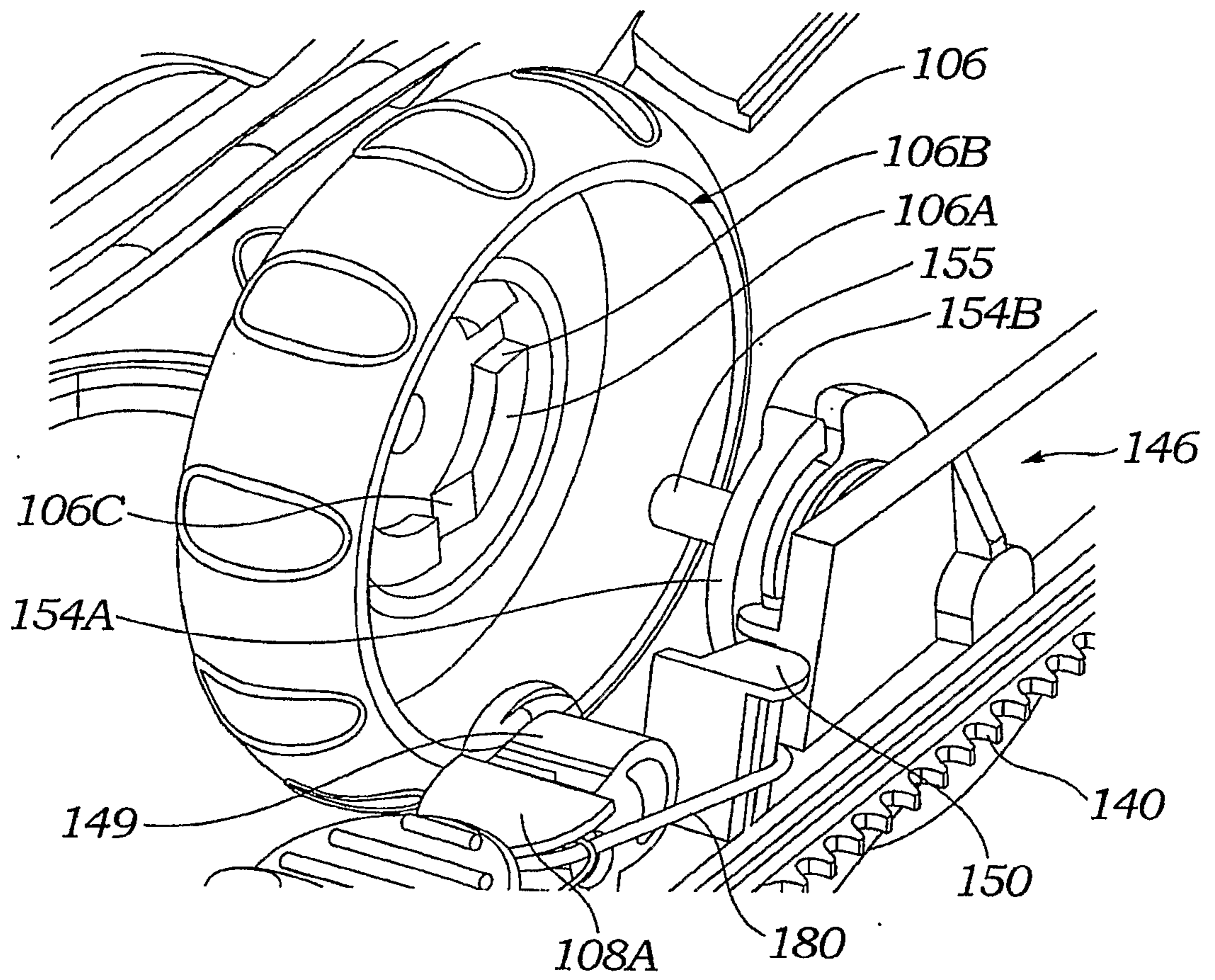

11/24

Fig. 11

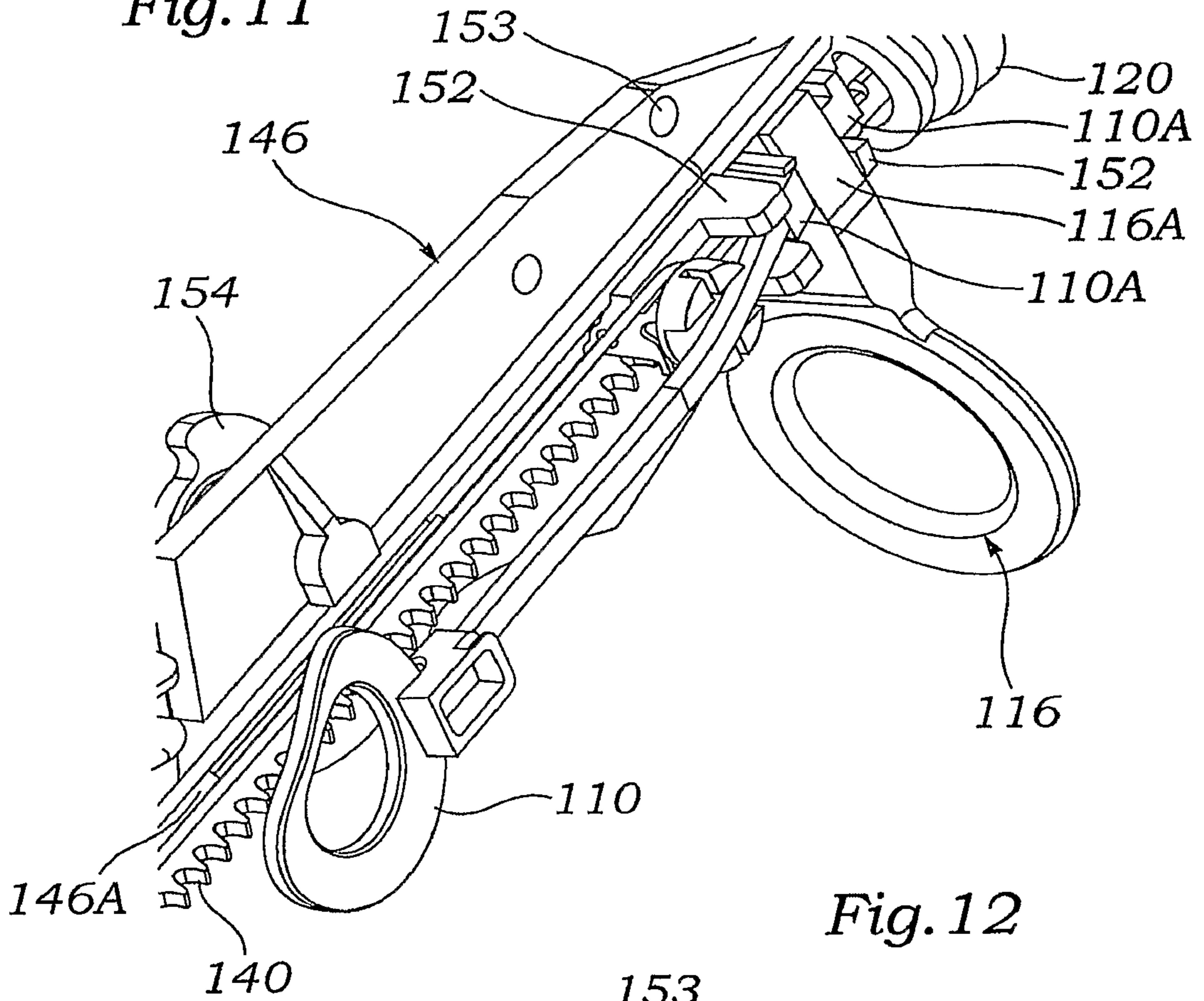
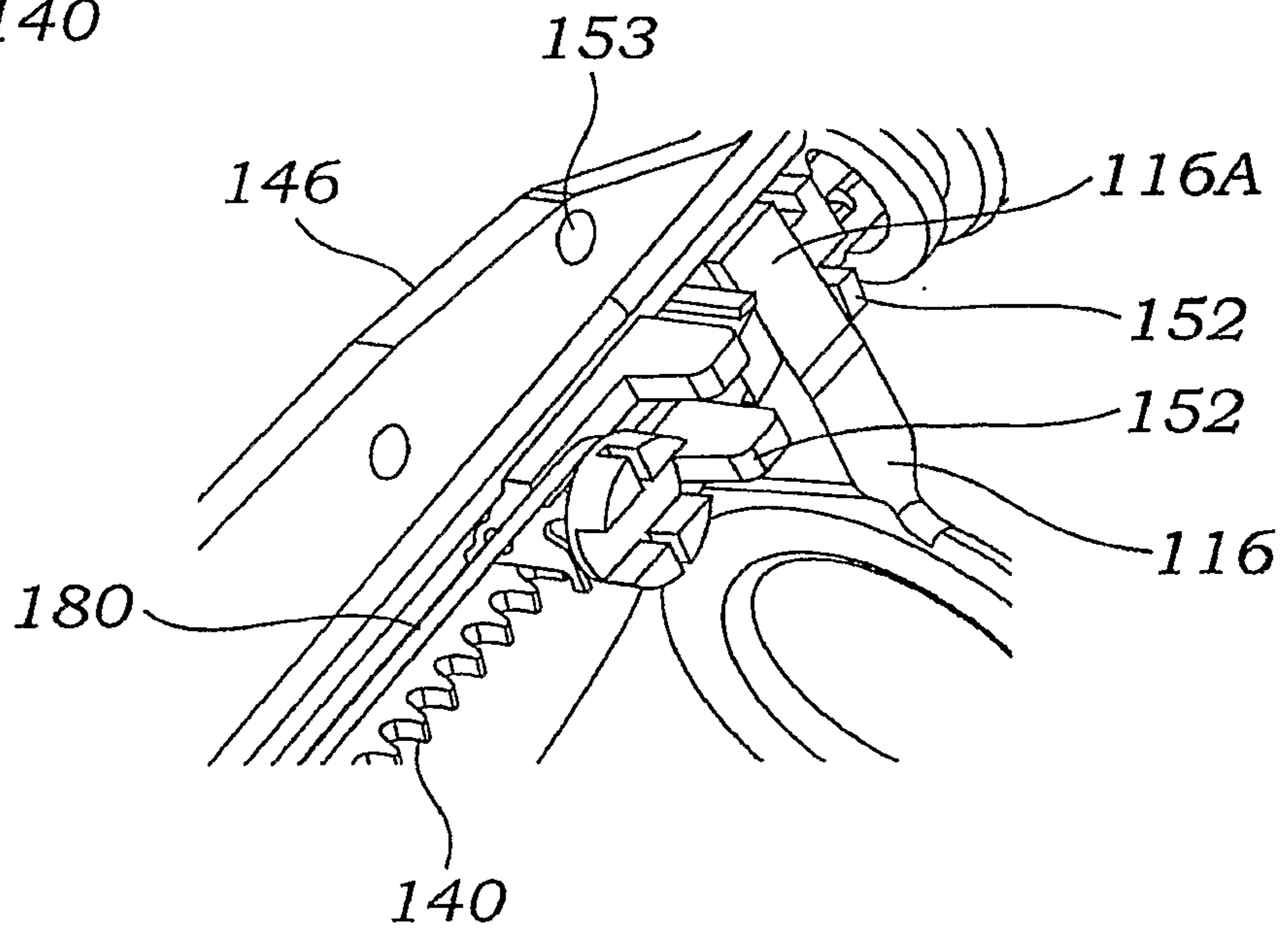
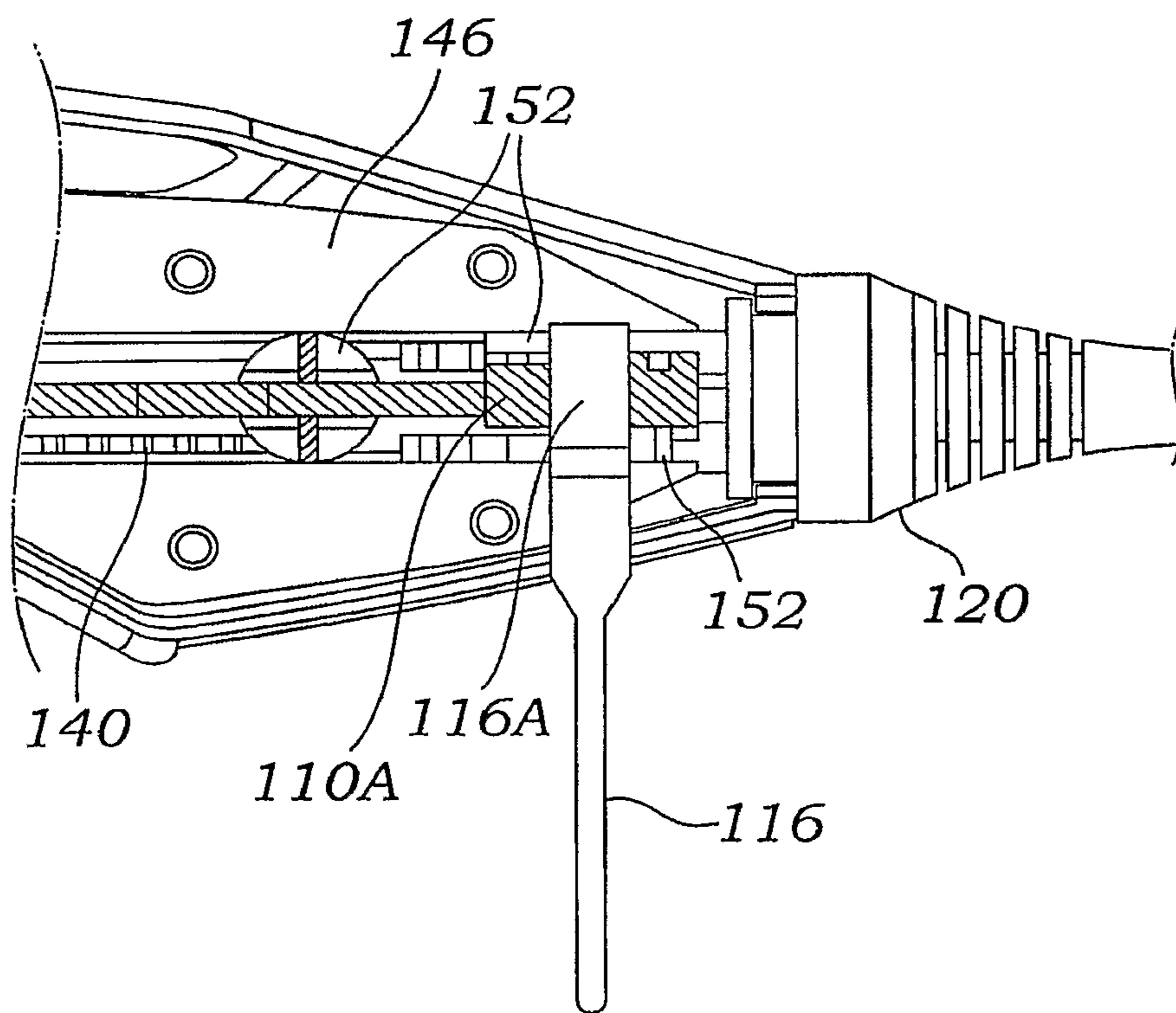

Fig. 12



12/24

Fig. 13



13/24

Fig. 14

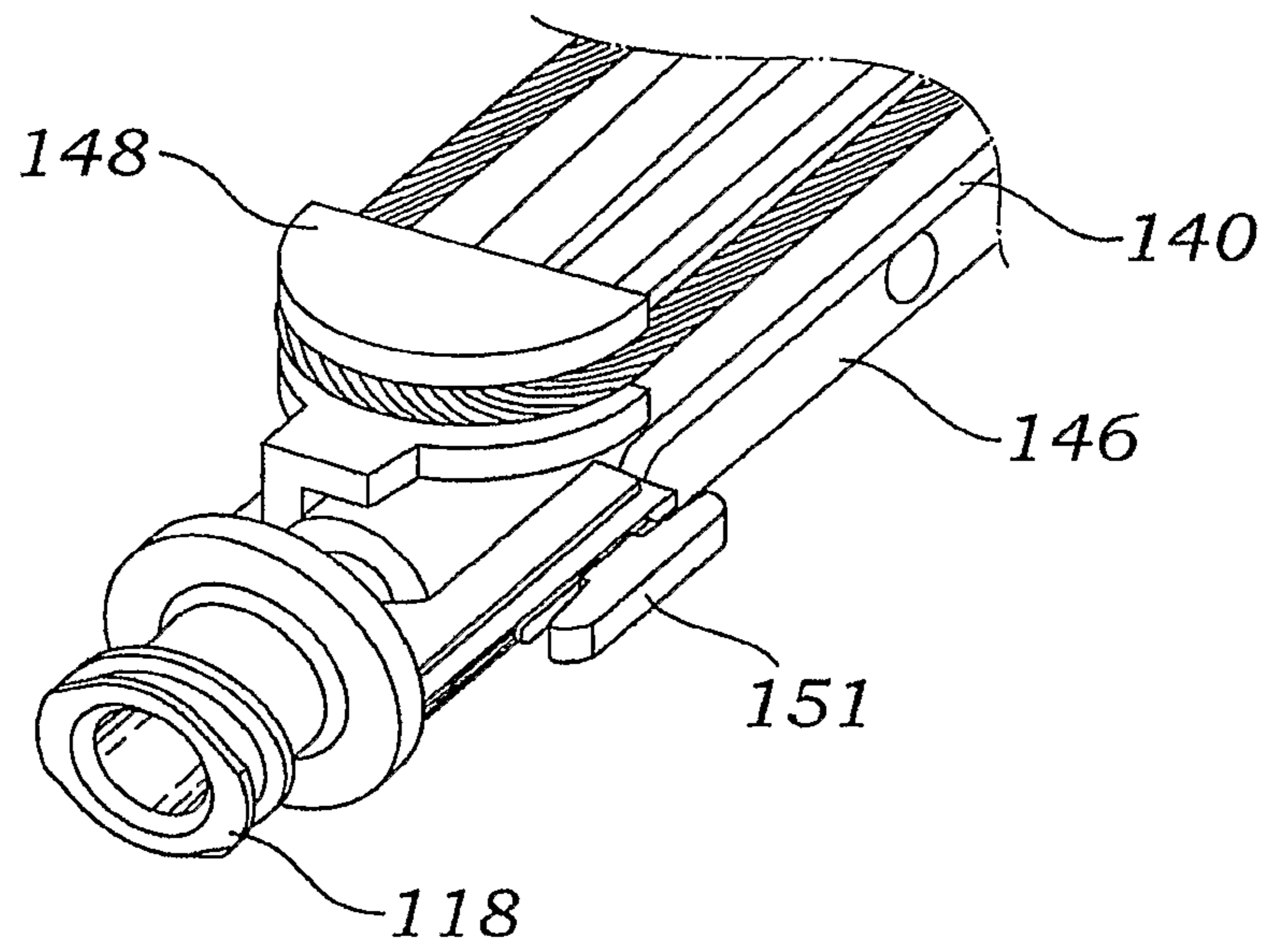

14/24

Fig. 15A

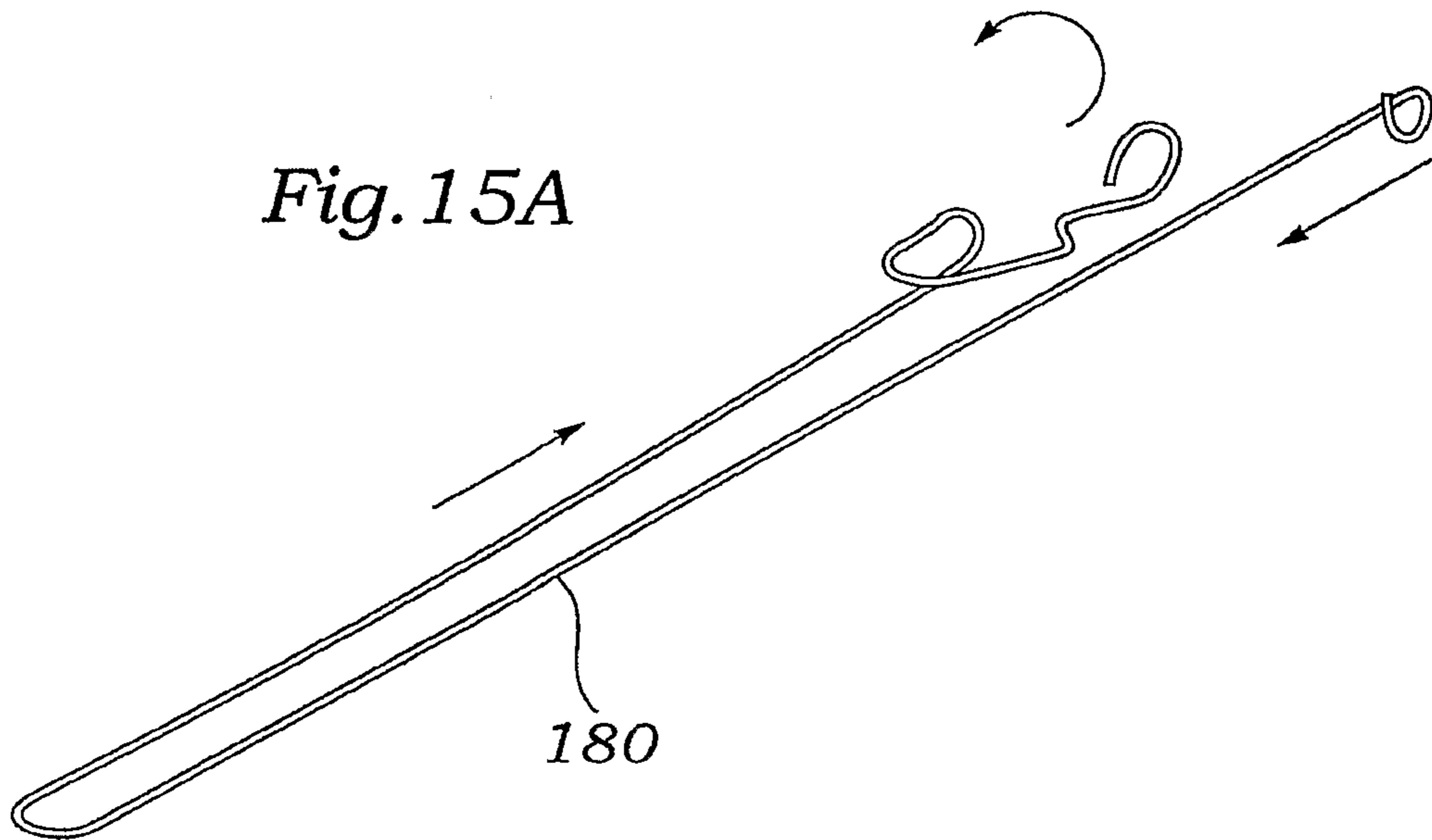

15/24

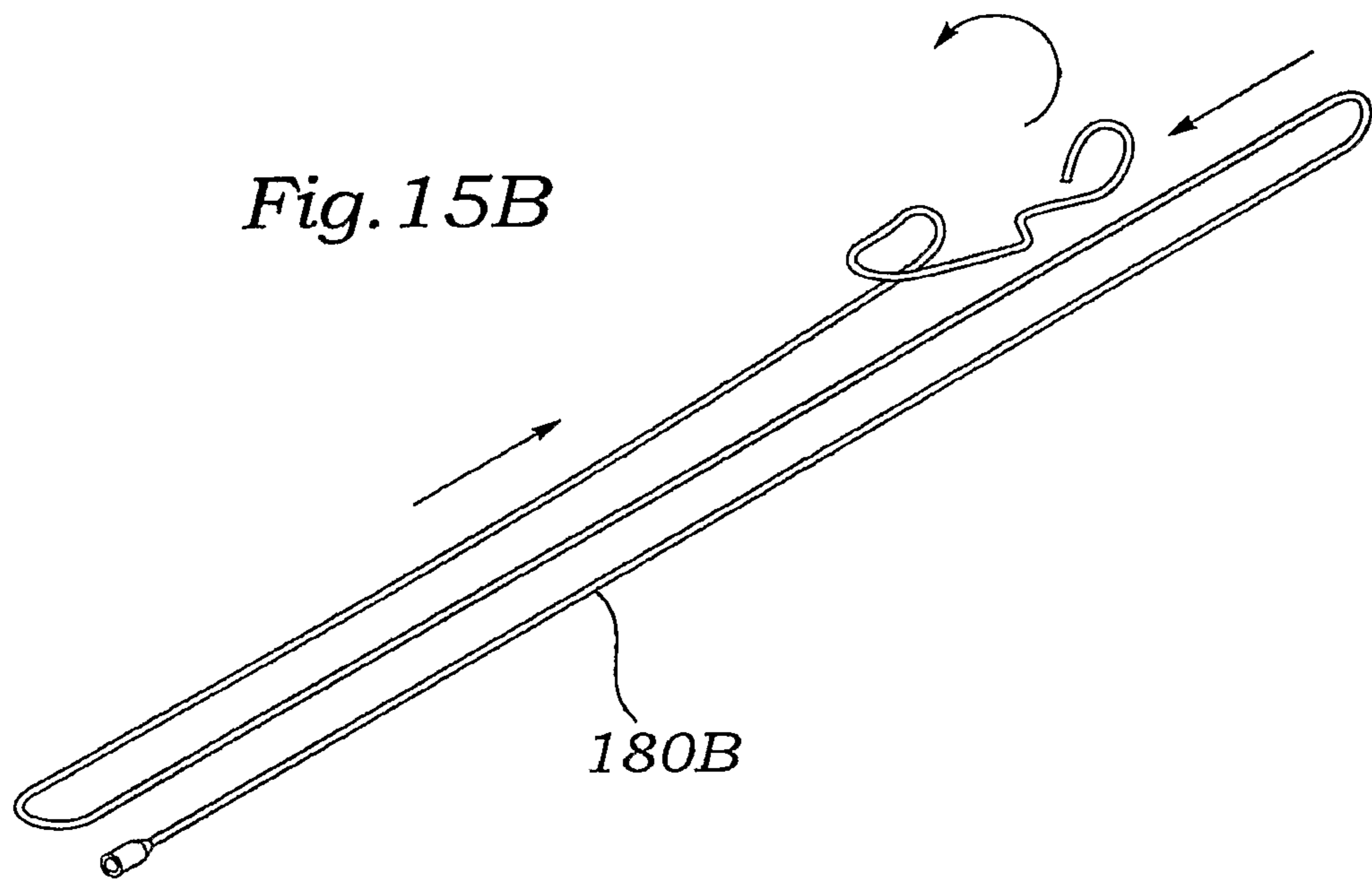

16/24

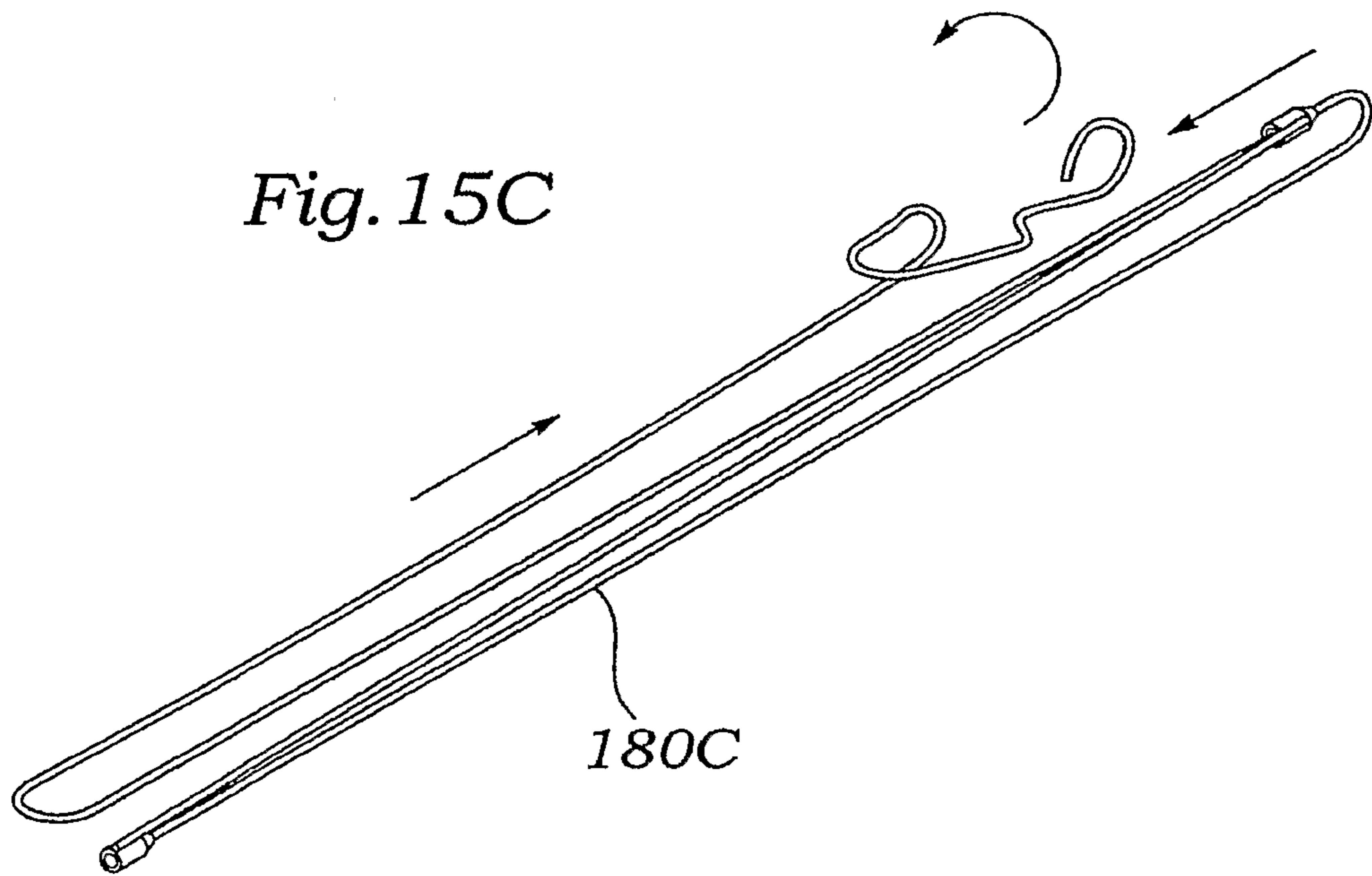

17/24

Fig. 15D

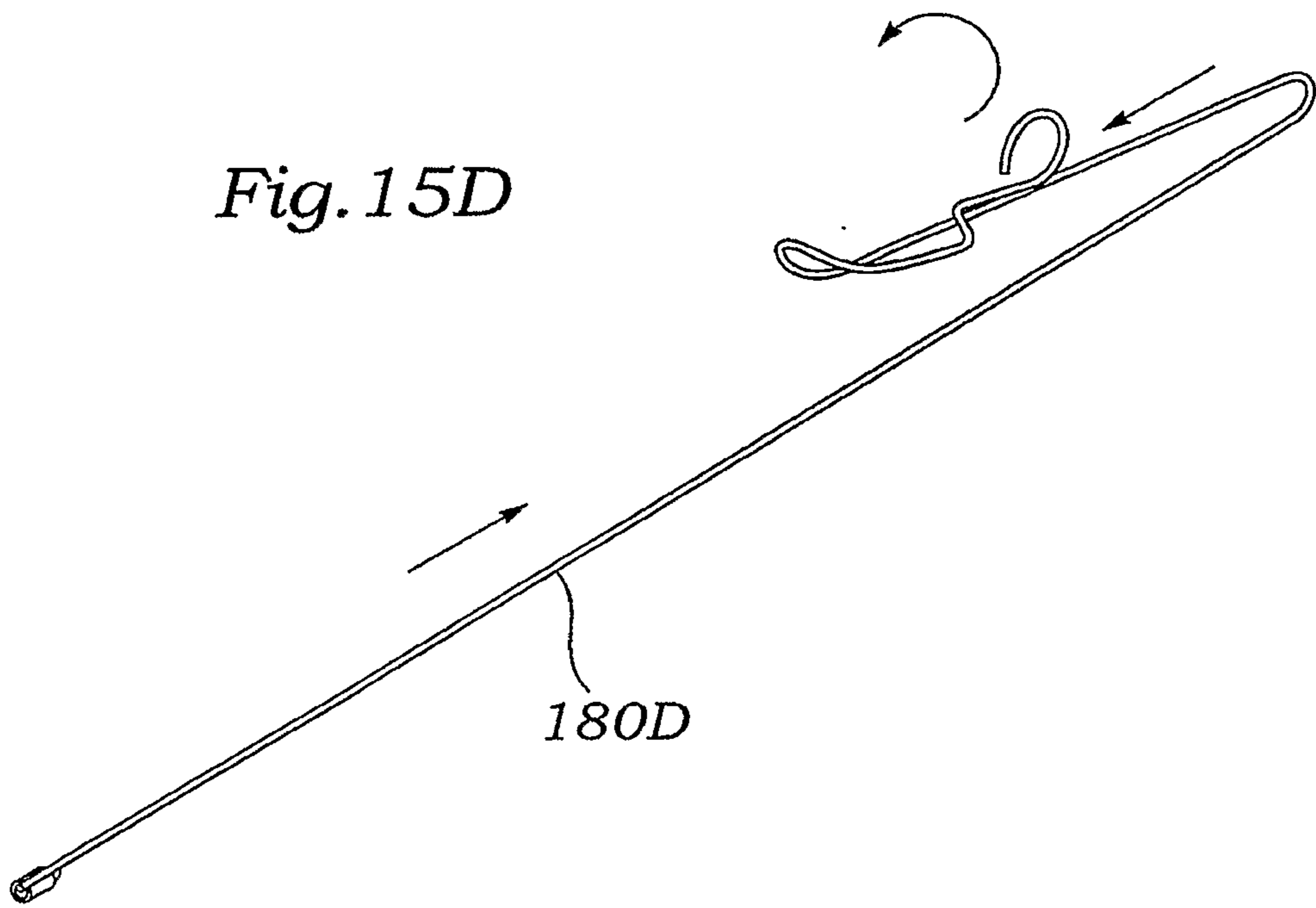

18/24

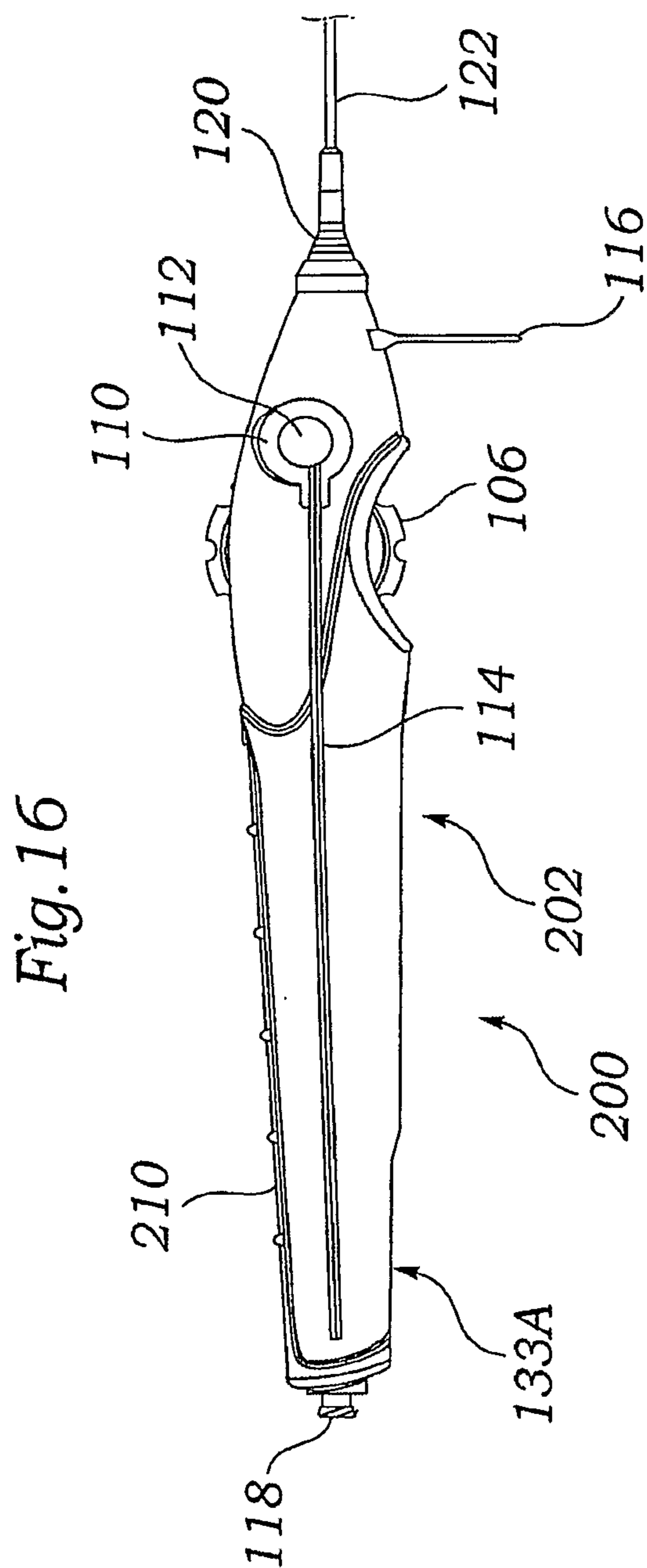
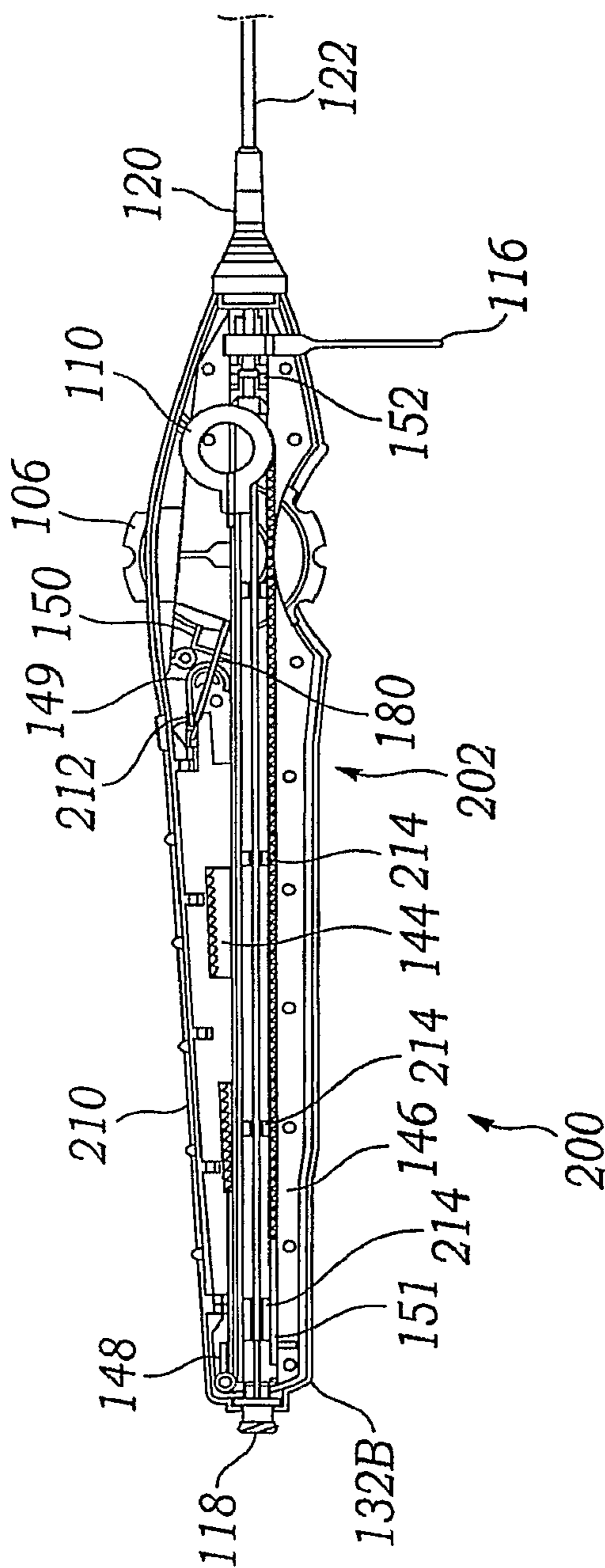
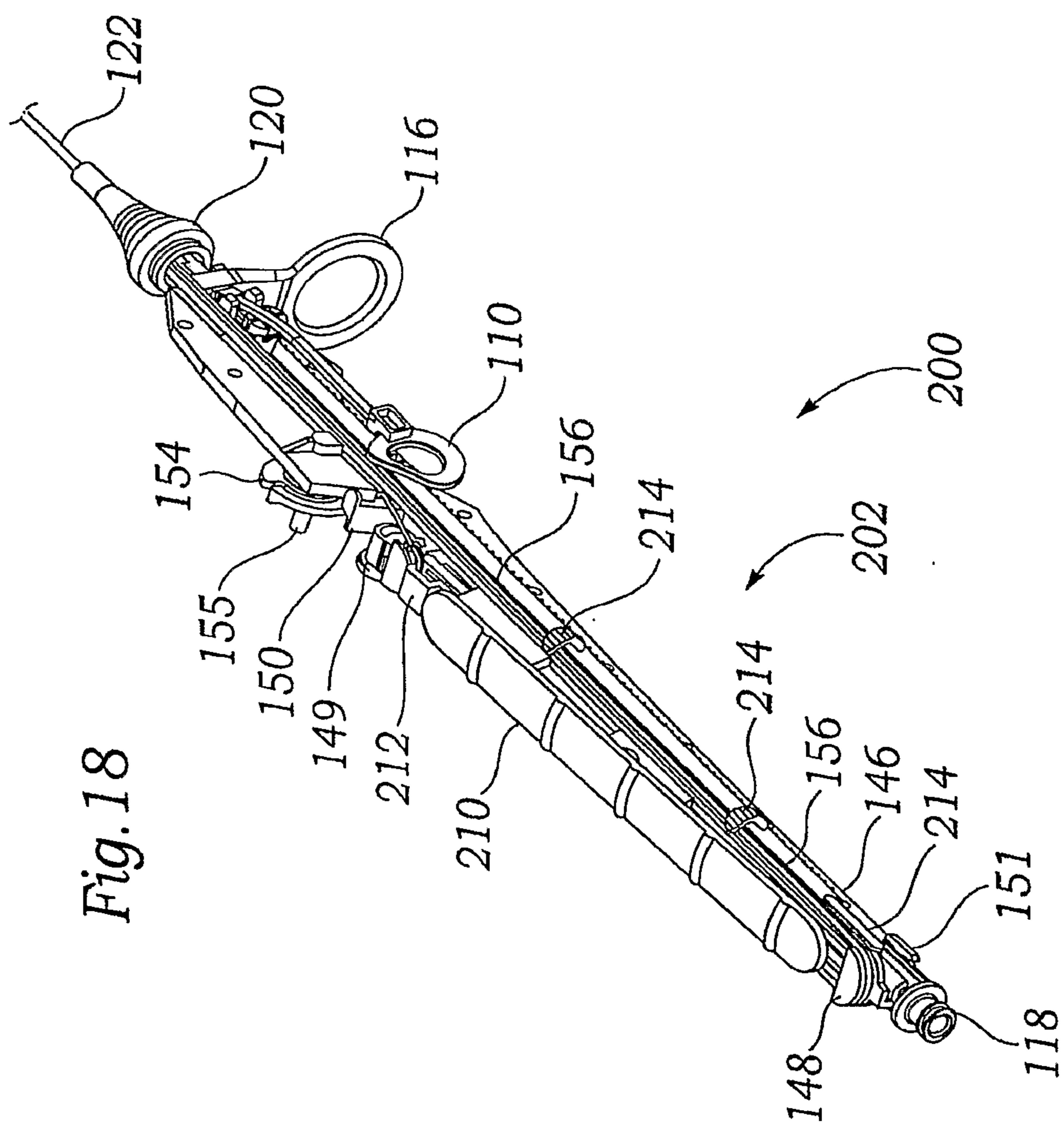

Fig. 17





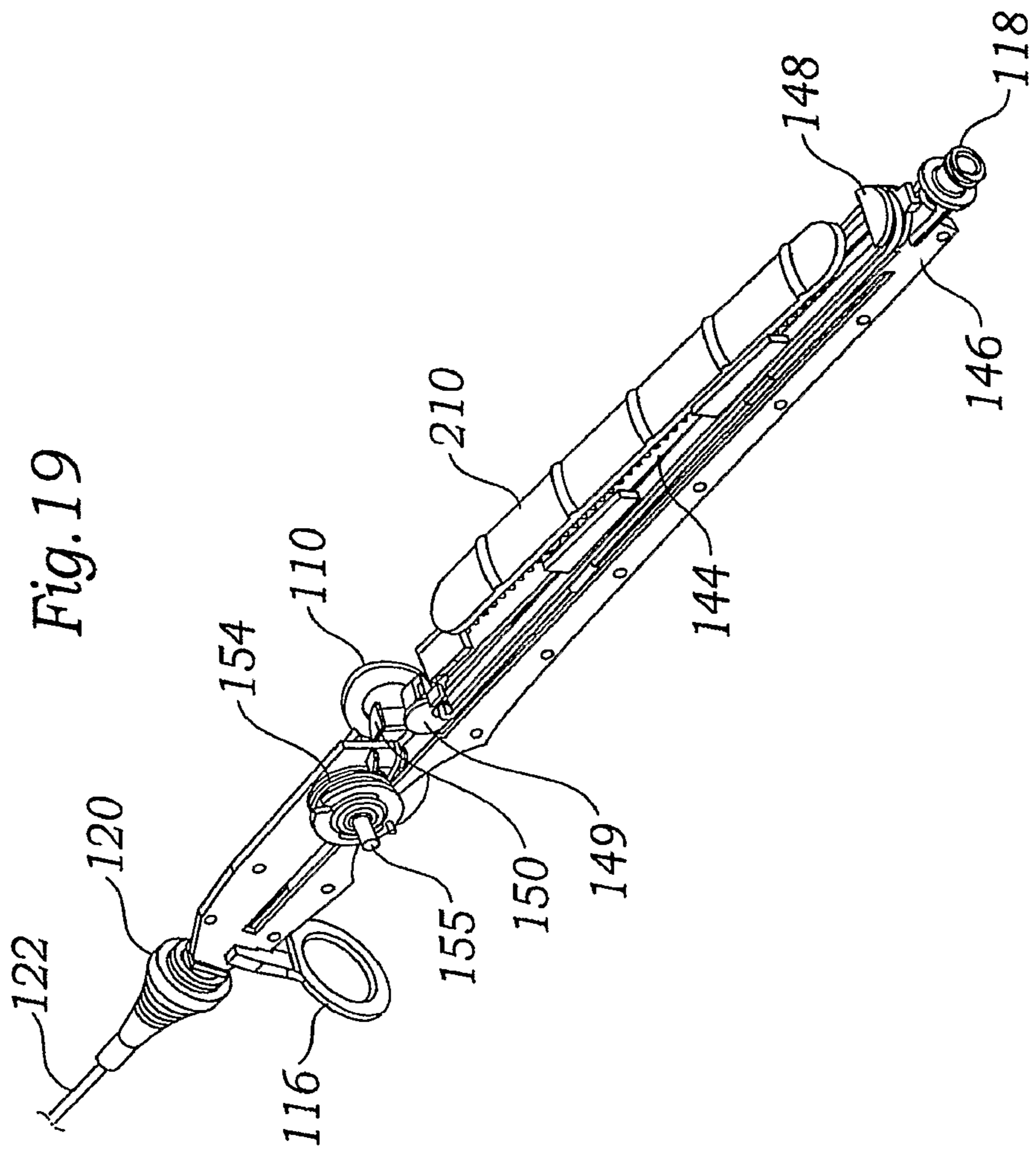
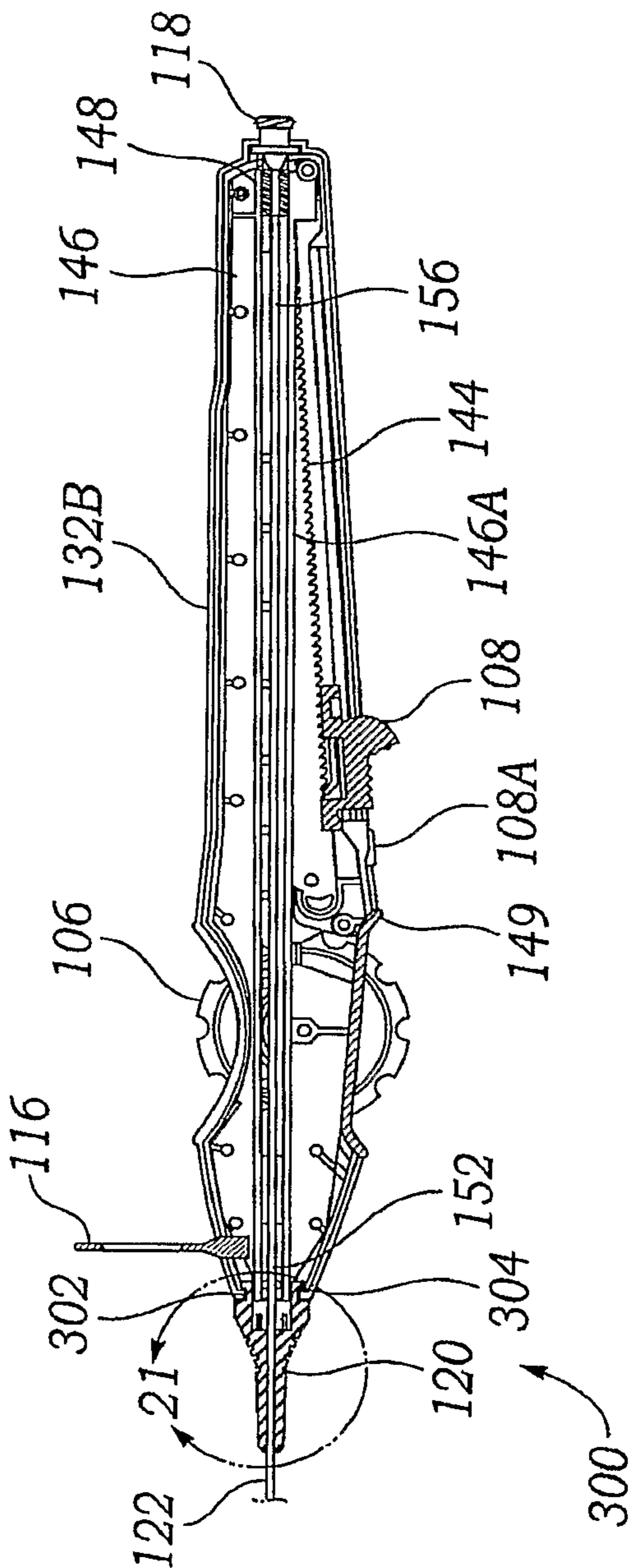
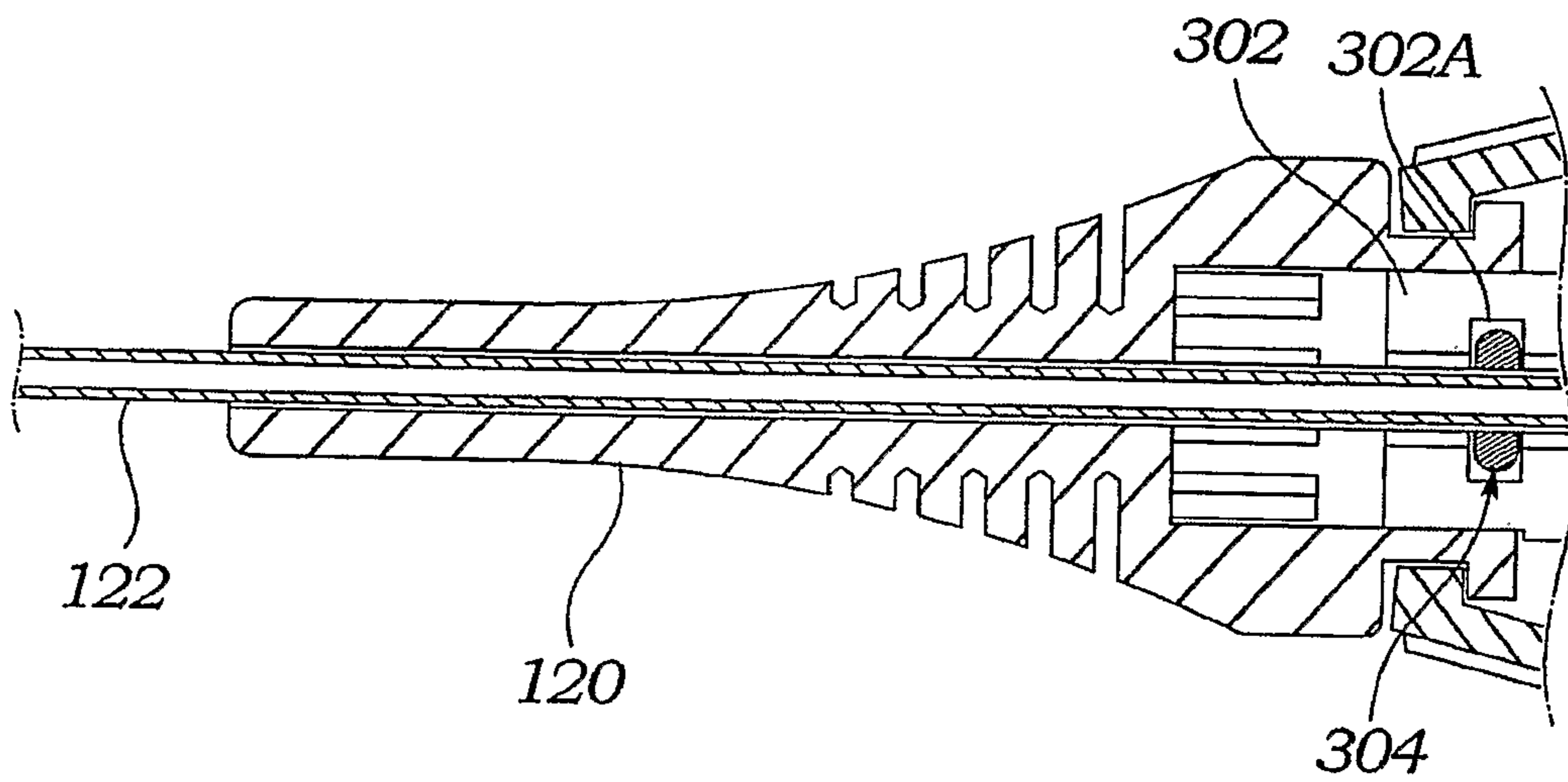

Fig. 20



23/24

Fig. 21



24/24

Fig. 22

