

(19) World Intellectual Property Organization
International Bureau



(43) International Publication Date
11 April 2002 (11.04.2002)

PCT

(10) International Publication Number
WO 02/28287 A1

- (51) International Patent Classification⁷: **A61B 17/02**, 19/00
- (21) International Application Number: PCT/US01/30745
- (22) International Filing Date: 2 October 2001 (02.10.2001)
- (25) Filing Language: English
- (26) Publication Language: English
- (30) Priority Data:
09/678,203 2 October 2000 (02.10.2000) US
- (71) Applicant: **MEDTRONIC, INC.** [US/US]; 710 Medtronic Parkway NE, Minneapolis, MN 55432 (US).
- (72) Inventors: **BORST, Cornelius**; Obrechtlaan 55, NL-3723 KB Bilthoven (NL). **MANSVELT-BECK, Hendricus, J.**; Bildzigt 14, NL-3721 KK Bilthoven (NL). **GRUNDEMAN, Paul, F.**; Lauriergracht 71 III, NL-1016 RH Amsterdam (NL). **VERLAAN, Conelius, W., J.**; Varenlaan 31, NL-3765 WJ Soest (NL).
- (74) Agents: **LATHAM, Daniel, W.** et al.; Medtronic, Inc. LC340, 710 Medtronic Parkway NE, Minneapolis, MN 55432 (US).
- (81) Designated States (*national*): AE, AG, AL, AM, AT, AU, AZ, BA, BB, BG, BR, BY, BZ, CA, CH, CN, CO, CR, CU, CZ, DE, DK, DM, DZ, EE, ES, FI, GB, GD, GE, GH, GM, HR, HU, ID, IL, IN, IS, JP, KE, KG, KP, KR, KZ, LC, LK, LR, LS, LT, LU, LV, MA, MD, MG, MK, MN, MW, MX, MZ, NO, NZ, PL, PT, RO, RU, SD, SE, SG, SI, SK, SL, TJ, TM, TR, TT, TZ, UA, UG, UZ, VN, YU, ZA, ZW.
- (84) Designated States (*regional*): ARIPO patent (GH, GM, KE, LS, MW, MZ, SD, SL, SZ, TZ, UG, ZW), Eurasian patent (AM, AZ, BY, KG, KZ, MD, RU, TJ, TM), European patent (AT, BE, CH, CY, DE, DK, ES, FI, FR, GB, GR, IE, IT, LU, MC, NL, PT, SE, TR), OAPI patent (BF, BJ, CF, CG, CI, CM, GA, GN, GQ, GW, ML, MR, NE, SN, TD, TG).
- Published:**
— with international search report
— before the expiration of the time limit for amending the claims and to be republished in the event of receipt of amendments
- For two-letter codes and other abbreviations, refer to the "Guidance Notes on Codes and Abbreviations" appearing at the beginning of each regular issue of the PCT Gazette.*



WO 02/28287 A1

(54) Title: METHOD AND APPARATUS FOR TEMPORARILY IMMOBILIZING A LOCAL AREA OF TISSUE

(57) Abstract: A method and apparatus for temporarily immobilizing a local area of tissue. In particular, the present invention provides a method and apparatus for temporarily immobilizing a local area of tissue within a patient's body cavity. In one embodiment, the tissue immobilized is heart tissue to thereby permit surgery on a coronary vessel in that area without significant deterioration of the pumping function of the beating heart. The local area of heart tissue is immobilized to a degree sufficient to permit minimally invasive or micro-surgery on that area of the heart. The apparatus for temporarily immobilizing a local area of tissue includes a first tissue engaging member and a second tissue engaging member coupled to a spreader. The spreader is operated by an actuator to selectively control the movement of the first tissue engager and the second tissue engager. The method for temporarily immobilizing a local area of tissue includes controlling the spreading of the first tissue engaging member and the second tissue engaging member so a selective amount of spreading occurs.

METHOD AND APPARATUS FOR TEMPORARILY IMMOBILIZING A LOCAL AREA OF TISSUE

FIELD OF THE INVENTION

The present invention generally relates to surgery on body tissues and organs. More specifically, the present invention relates to a method and apparatus for temporarily immobilizing a local area of tissue subject to motion, such as the heart wall, which permits a surgical procedure to be performed on that local area of tissue.

BACKGROUND OF THE INVENTION

Coronary artery disease remains the leading cause of morbidity and mortality in Western societies. Coronary artery disease is manifested in a number of ways. For example, disease of the coronary arteries can lead to insufficient blood flow to various areas of the heart. This can lead to the discomfort of angina and the risk of ischemia. In severe cases, acute blockage of coronary blood flow can result in irreversible damage to the myocardial tissue including myocardial infarction and the risk of death.

A number of approaches have been developed for treating coronary artery disease. In less severe cases, it is often sufficient to merely treat the symptoms, with pharmaceuticals, or treat the underlying causes of the disease, with lifestyle modification. In more severe cases, the coronary blockage can be treated endovascularly or percutaneously using techniques such as balloon angioplasty, atherectomy, laser ablation, stents, and the like.

In cases where these approaches have failed or are likely to fail, it is often necessary to perform a coronary artery bypass graft procedure. This procedure generally consists of the following steps: First, direct access to the heart is achieved. This is usually done by opening the chest by median sternotomy and spreading the left and right rib cage apart; and opening the pericardial sac to achieve direct access to the heart.

Next, a blood vessel or vessels for use in the graft procedure are mobilized from the patient. This usually entails mobilizing either a mammary artery or a saphenous vein, although other graft vessels may also be used.

Next, a heart-lung or cardiopulmonary bypass is performed. This usually entails arterial and venous cannulation, connecting the bloodstream to a heart-lung machine, cooling the body to about 32 degrees Celsius, cross-clamping of the aorta and

cardioplegic perfusion of the coronary arteries to arrest and cool the heart to about 4 degrees Celsius. The arrest or stoppage of the heart is generally required because the constant pumping motion of the beating heart would make surgery upon the heart difficult in some locations and extremely difficult if not impossible in other locations

Once cardiac arrest is achieved, then a graft (or grafts) is attached to the relevant portions of a coronary artery (or arteries) followed by weaning from the cardiopulmonary bypass, restarting the heart and decannulation. Finally the chest is closed.

One area which may create difficulties for the patient and extra expense and time for the procedure involves the cardiopulmonary bypass. In a cardiopulmonary bypass all the patient's blood, which normally returns to the right atrium, is diverted to a system which supplies oxygen to the blood and removes carbon dioxide and returns the blood, at sufficient pressure, into the patient's aorta for further distribution into the body. Generally such a system requires several separate components, including an oxygenator, several pumps, a reservoir, a blood temperature control system, filters as well as flow, pressure and temperature sensors.

Problems may develop during cardiopulmonary bypass due to the reaction blood has to non-endothelially lined surfaces, i.e. surfaces unlike those of a blood vessel. In particular, exposure of blood to foreign surfaces results in the activation of virtually all the humoral and cellular components of the inflammatory response, as well as some of the slower reacting specific immune responses. Other complications from cardiopulmonary bypass include loss of red blood cells and platelets due to shear stress damage. In addition, cardiopulmonary bypass requires the use of an anticoagulant, such as heparin. This may, in turn, increase the risk of hemorrhage. Finally cardiopulmonary bypass sometimes necessitates giving additional blood to the patient. The additional blood, if from a source other than the patient, may expose the patient to blood born diseases.

Due to the risks incurred during cardiopulmonary bypass, others have attempted to perform a coronary artery bypass graft procedure without cardiac arrest and cardiopulmonary bypass. For example, Trapp and Bisarya in "Placement of Coronary Artery Bypass Graft Without Pump Oxygenator", *Annals Thorac. Surg.* Vol. 19, No. 1, (Jan. 1975) pgs. 1-9, immobilized the area of the bypass graft by encircling sutures deep

enough to incorporate enough muscle to suspend an area of the heart and prevent damage to the coronary artery. More recently Fanning et al. in "Reoperative Coronary Artery Bypass Grafting Without Cardiopulmonary Bypass", *Annals Thorac. Surg.* Vol. 55, (Feb. 1993) pgs. 486-489 also reported immobilizing the area of the bypass graft with stabilization sutures.

While these attempts have achieved some success, they generally require enhanced skill of the surgeon to properly create the anastomosis because, even with sutures, the beating heart continues to move in the relevant area more than desired.

SUMMARY OF THE INVENTION

In one embodiment of the invention, an actuator is configured to operate a spreader to selectively control the movement of a first tissue engaging member among a first position, a second position, and at least a third position, and selectively control the movement of the second tissue engaging member among a first position, a second position and at least a third position. The first tissue engaging member and the second tissue engaging member are coupled to the spreader. The spreader is carried on an arm distal end and the actuator is carried on the arm proximal end.

In another embodiment of the invention, the first tissue engaging member and the second tissue engaging member are further spread once they are coupled to a tissue surface to place the tissue between the first tissue engaging member and the second tissue engaging member under tension.

In still another embodiment of the invention, a method is employed to introduce the first tissue engaging member and second tissue engaging members into a patient's body. The tissue engaging members are spread and this spreading is controlled so a selective amount of spreading occurs. After the tissue engaging member have been spread a selective amount, the tissue engaging members are coupled to the tissue surface desired to be stabilized.

BRIEF DESCRIPTION OF THE DRAWINGS

The foregoing and other aspects of the present invention will best be appreciated with reference to the detailed description of the invention in conjunction with the accompanying drawings, wherein:

FIG. 1 is a plan view of the device being used to temporarily immobilize a local area of heart tissue in which access to the heart is achieved through a mini-thoractomy.

FIGS. 2a and 2b depict a first type of suction device shown in use in FIG. 1.

FIGS. 3a and 3b depict a second type of suction device shown in use in FIG. 1.

FIG. 4 is a longitudinal sectional view of the suction paddle used in the present invention.

FIG. 5 is a cross-sectional view of the suction paddle used in the present invention taken along the line 5-5 of FIG. 4.

FIG. 6 is a longitudinal sectional view of the suction arm used in the present invention.

FIG. 7 is a plan view of the suction arm used in the present invention.

FIG. 8 is a detailed view of a pair of suction devices being positioned on a heart and spread apart.

FIGS. 9 and 10 show the effect of the spread-apart motion depicted in FIG. 8.

FIG. 11 is an example of the motion in the plane parallel to the surface of the heart of a point on heart tissue during one half respiratory cycle when the heart is unrestrained and also depicting the motion of the same point on heart tissue when the suction devices are used.

FIG. 12 is an enlarged portion of FIG. 11 depicting the motion of the same point on heart tissue when the suction devices are used.

FIG. 13 is an alternate embodiment of the present invention.

FIG. 14 is a plan view of the device being used to temporarily immobilize a local area of heart tissue in which access to the heart is achieved through a median sternotomy.

FIG. 15 is a side view of an alternate embodiment of the present invention, shown placed against the surface of the heart.

FIG. 16 is a bottom view of the alternate embodiment of the present invention device shown in FIG. 15.

FIG. 17 is a side view of a further alternate embodiment of the present invention, shown placed against the surface of the heart.

FIG. 18 is a bottom view of still further alternate embodiment of the present invention.

FIG. 19 is a cross-sectional view of a body showing an alternative method of achieving access to the surface of the heart, and in particular of achieving such access using minimally invasive trocars.

FIG. 20A is a cross-sectional view of a body showing an alternate embodiment of the present invention, and in particular, an alternate embodiment of the securing device.

FIG. 20B is a top view of the embodiment shown in FIG.20A.

FIG. 21 is a perspective view of a securing device.

FIG. 22 depicts an overhead view of the securing device.

FIG. 23 is a side view of an alternate embodiment of suction device.

FIG. 24 is a further alternate embodiment of a suction device.

FIG. 25 is a perspective view of an alternate embodiment of an immobilizing device.

FIG. 26A is a view of the bottom of an alternate embodiment of a suction paddle used in the immobilizing device.

FIG. 26B is a perspective view of a further alternate embodiment of a suction paddle used in the immobilizing device.

FIG. 27 is a perspective view of a turning handle used to bend or orient the suction paddle portion of the immobilizing device.

FIG. 28 is a bottom view of an alternate embodiment of immobilizing device.

FIG. 29 is a plan view of a spreader used in an alternate embodiment of the present invention.

FIG. 30 depicts an alternate embodiment of spreader.

FIG. 31 depicts an alternate embodiment of immobilizing device and, in particular, an alternate embodiment of the securing device used to secure each suction paddle to the operating table rail.

FIG. 32 is a cross sectional view of the arm shown in FIG. 31.

FIG. 33 depicts a further alternate embodiment of the present invention, and in particular of a suction device substantially similar to that shown in FIG. 13 but for that the suction ports are located at the top of the suction paddle.

FIG. 34 depicts a further alternate embodiment of the present invention, and in particular of a suction device that may be used in an endoscopic procedure featuring an arm, and a pair of tissue engaging members and a spreader.

FIG. 35 is a longitudinal cross-sectional view of the distal end of a suction device.

FIG. 36 is a longitudinal cross-sectional view of the distal end of a suction device.

FIG. 37 is a bottom view of a spreader with coupled suction paddles in a non-spread position.

FIG. 38 is a bottom view of spreader with coupled suction paddles in a spread position.

FIG. 39 is a plan view of a spreader member.

FIG. 40 is a plan view of a spreader member.

FIG. 41 is a plan view of a slide component of a spreader.

FIG. 42 is a side view of a slide component of a spreader.

FIG. 43 is a side view of an anchor component of a spreader.

FIG. 44 is a plan view of an anchor component of a spreader.

FIG. 45 depicts a further alternate embodiment of the present invention, and in particular of a suction device that may be used in an endoscopic procedure featuring an arm, and a pair of tissue engaging members and a spreader.

FIG. 46 depicts an alternate embodiment of of the present invention, and in particular of a suction device that may be used in an endoscopic procedure featuring an arm with joints, and a pair of tissue engaging members and a spreader.

FIG. 47 is a side view of a joint.

FIG. 48 is a cross-sectional view of a body showing one method of achieving access to a surface of the heart and using the present invention to immobilize an area of tissue.

FIG. 49 depicts a further alternate embodiment of the present invention, and in particular of a suction device that may be used in an endoscopic procedure, as described earlier, featuring an arm with joints, and a pair of tissue engaging members and a spreader.

FIG. 50 depicts a further alternate embodiment of the present invention, and in particular of a suction device that may be used in an endoscopic procedure, as described earlier, featuring an arm with joints, and a pair of tissue engaging members and a spreader.

FIG. 51 depicts a further alternate embodiment of the present invention, and in particular of a suction device that may be used in an endoscopic procedure, as described earlier, featuring an arm with joints, and a pair of tissue engaging members and a spreader.

FIG. 52 depicts a further alternate embodiment of the present invention, and in particular of a suction device that may be used in an endoscopic procedure, as described earlier, featuring an arm with joints, and a pair of tissue engaging members and a spreader.

FIG. 53 depicts a further alternate embodiment of the present invention, and in particular of a suction device that may be used in an endoscopic procedure, as described earlier, featuring an arm with joints, and a pair of tissue engaging members and a spreader.

FIG. 54 depicts a further alternate embodiment of the present invention, and in particular of a suction device that may be used in an endoscopic procedure, as described earlier, featuring an arm with joints, and a pair of tissue engaging members and a spreader.

FIG. 55 depicts a further alternate embodiment of the present invention, and in particular of a suction device that may be used in an endoscopic procedure, as described earlier, featuring an arm with joints, and a pair of tissue engaging members and a spreader.

FIG. 56 is a bottom view of an alternate embodiment of suction paddle of the present invention.

FIG. 57 is a side view of an alternate embodiment of suction paddle of the present invention.

The drawings are not necessarily to scale.

DETAILED DESCRIPTION OF THE PREFERRED EMBODIMENT

FIG. 1 is a view of the immobilizing device 11 being used to temporarily immobilize an area of heart tissue. In the preferred embodiment, surgical access to the local area of heart tissue is achieved through a mini-thoracotomy, preferably performed within either the fourth or fifth intercostal space. An incision 10 of approximately 10 centimeters is made into chest cavity between the ribs (seen here in phantom.) The rib cartilage may be temporarily removed and the ribs surrounding the incision slightly spread apart using a retractor (not shown) to provide adequate surgical access to the mammary artery and the heart. As seen, a pair of suction devices 12, 13 are introduced. The first suction device 12 is introduced through a small stab wound 8 in between the ribs approximately 10 cm. below incision 10. This stab wound is made in any acceptable manner. Incidentally, once the surgery has been completed, the stab wound may be used for the thorax drain after the closure of the chest. As discussed below with reference to FIG. 19, the suction device has a covering 180, made from latex rubber, over the distal end when it penetrates the chest wall in order to avoid blood and tissue from entering the suction ports and block suction apertures. Once suction device is introduced, covering 180 is removed and the distal end is positioned onto heart. The second suction device 13 is introduced through incision 10 onto the surface of the heart. As seen, the distal end of each suction device is ultimately positioned in the local area of heart tissue to be immobilized, i.e. on either side of a coronary artery upon which a graft is to be made.

As seen, suction devices 12, 13 are secured using securing devices 14, 15 respectively to a stationary object, such as surgical table 16. Of course other objects besides the surgical table may be used as a stationary object, including the floor, ceiling or

even the patient, such as a portion of the skeletal system of the patient, e.g. the sternum. In the preferred embodiment, each securing device 14,15 is a variable friction arm, model no. 244 available from Manfrotto Nord, Inc. of Zona Industriale di Villapaiera, I-32032 Feltre BL, Italy. Each securing device 14, 15 has a series of variable elbow joints 17 which may be locked in position. Thus the securing device permits the suction device to be locked into any position desired within three-dimensional space. Although not shown, each securing device (or each suction device or both) may also be interconnected such that a truss type structure is created and the entire stiffness or rigidity of the immobilizing device 11 is improved.

Suction devices 12, 13 are coupled to a suction source 114 through lines 20, 21. Suction source 114 is preferably the standard suction available in the operating room and coupled to the devices with a two liter buffer flask (not shown) for each device. Suction is provided at a negative pressure of between 200-600 mm Hg with 400 mm Hg preferred. As seen, each suction device has essentially two portions, a paddle 22 and an arm 23. FIGS. 2 and 3 detail suction devices 12 and 13 respectively.

Turning now to FIGS. 2a and 2b, FIG. 2a is a side view of a suction device 12 showing its placement against the outline of a heart. As seen, the distal end of suction device 12 comprises a paddle 22 and arm 23 coupled together by a continuous hinge or neck 71. Paddle 22 has a generally planar surface which conforms generally to the curvature of a heart 1, shown here in outline. In the preferred embodiment, suction arm 23 is coupled to suction paddle 22 such that suction paddle 22 may be rotated or bent to achieve the desired orientation relative to arm 23. This is accomplished by neck 71. Neck 71 is fashioned to be relatively bendable, that is to be bent by hand into the desired orientation, as opposed to paddle 22 and arm 23, which are rigid. In the preferred embodiment suction paddle 22 and suction arm 23 are constructed of stainless steel 316, while neck 71 is constructed of stainless steel 321. Of course other means may be provided to permit paddle 22 to move or rotate relative to arm 23 other than making neck 71 to be malleable by hand, such as a locking hinge as well as a remotely actuable joint, as is well known in the art. See for example, U.S. Patent No. 5,374,277 of Hassler, incorporated herein by reference. A remotely actuable hinge is believed particularly advantageous for a suction device used endoscopically. In an alternate embodiment paddle may be fixed in a rigid orientation

relative to arm. As seen, arm 23 has a suction lumen 30 therethrough which communicates with a suction conduit 31 in paddle 22 through neck lumen 72. Suction conduit 31 in paddle 22 further communicates through suction hole 32 (best seen in FIG. 2b) to suction port 33.

FIG. 2b is a view of the bottom of suction device 12. As seen, in the preferred embodiment four suction ports 33 in a row are featured, although the specific or exact number and position used may vary. Each suction port 33 has a suction aperture 32, each of which are preferably located at a position off-center from suction port 33. Suction apertures 32 are positioned off center from suction ports 33 so that if a large upwelling of tissue is caused by the suction (which may occur as a blister or bell-shaped curve) the tissue will not immediately close off the suction by obstructing suction aperture 32, as it would if the aperture were in the center of suction port 33. In addition, each suction aperture 32 has a much smaller diameter as compared to the diameter of suction port 33. This creates a high resistance pathway between suction port 33 and suction conduit 31 which permits the loss of a tissue-to-port seal in one suction port (and thus loss of fixation of the suction port to the tissue) to not also cause a precipitous pressure drop in the remainder of the suction ports. In the preferred embodiment suction aperture 32 has a diameter of 2 mm and suction port 33 has a diameter of 6 mm. As can be seen through a comparison between FIGS. 2A and 2B the relatively straight sided suction ports define a generally planar surface through the ends of each port.

Turning now to FIGS. 3a and 3b, FIG. 3a is a side view of a suction device 13 shown in FIG. 1. As seen, the distal end of suction device 13 comprises paddle 22 and arm 23 coupled together by a continuous hinge or neck 71. Paddle 22 has a generally planar surface which conforms generally to the curvature of a heart 1. In the preferred embodiment, suction arm 23 is coupled to suction paddle 22 such that suction paddle 22 may be rotated or bent along any of the three axes to achieve the desired orientation relative to arm 23. This is accomplished by neck 71. Neck 71 is substantially similar to that discussed in FIG. 2a but for the fact that suction device 13 has suction paddle 22 at an angled orientation to suction arm 23. In the preferred embodiment suction paddle 22 of suction device 13 is perpendicular to suction arm 23, although other angular orientations may be used.

FIG. 3b is a view of the bottom of suction device 13. As seen, in the preferred embodiment suction paddle 22 of suction device 13 is substantially similar to that described in FIG. 2b. In the preferred embodiment suction aperture 32 has a diameter of 2 mm and suction port 33 has a diameter of 6 mm.

FIG. 4 is a longitudinal cross-sectional view of suction paddle 22 used in immobilizing device 11. As seen, paddle 22 has a series of suction ports 33 each of which is connected to suction conduit 31 through a suction aperture 32. Each suction port 33 has generally straight, cylindrical sides. Of course other configurations may be used, such as cone-shaped suction ports, dome-shaped suction ports, etc. As can be seen through this FIG. it is the bottoms or ends themselves of the suction ports define a generally planar surface through the ends of each port along the bottom surface of the paddle. Moreover, although shown here as conjoined or defining a continuous surface, suction ports may be further arranged such that they are each separate and distinct from one another, but which would still define a planar surface along through their ends along the bottom of the paddle.

FIG. 5 is a cross-sectional view of the suction paddle 22 taken along the line 5-5 of FIG. 4. As seen, suction port 33 is connected to suction conduit 31 through suction aperture 32. Suction paddle 22 has a canted or slanted surface 36 at the top. Through this type of surface, area 37 may be better accessed for performing surgical procedures.

FIG. 6 is a longitudinal cross-sectional view of suction arm 23. Distal end 71 of suction arm 23 has neck 71 (not shown in this FIG.) fixed thereto. As seen, arm 23 has a suction lumen 30 therethrough which communicates with suction conduit 31 in paddle 22 through neck lumen 72 of neck 71 (shown in phantom in this FIG.). As seen in FIG. 7, which is a plan view of suction arm 23, proximal end 75 has a series of knurled ridges 76 to facilitate coupling a suction line coming from suction source (not shown in this FIG) to suction arm 23.

FIG. 8 is a detailed view of a pair of suction devices 12, 13 being positioned on a heart and spread apart. As seen, paddles 22, 27 of each device generally

are placed in the area 34 in which temporary immobilization of the heart tissue is desired. When used for a coronary bypass graft, area 34 typically will have a coronary artery 35 running therethrough. Area 34 is between paddles 22, 27. Once placed about area 34, suction is then created in the suction ports (not shown in this view.) Through the suction, the device then is fixed to or grabs hold of the heart tissue.

Once the suction is created and the paddles are secured to the heart tissue, each of the suction devices are then spread slightly apart as shown by the arrows 40, 41 to the positions shown as 42, 43. The effect of this spreading apart is to cause a tension to be created in the area 34 of the heart tissue between the paddles. The tension causes the area 34 to be further immobilized, and in particular in the Z-direction, i.e. in the direction normal to the plane defined by the surface of the heart. This is represented in FIGS. 9 and 10.

As seen in FIG. 9, the area of heart tissue between the paddles, even with the placement of the paddles, still has some vertical motion, shown here as arrow 50. When paddles 22, 27 are slightly spread apart to cause a tension in that area 34 of tissue between the paddles, as depicted in FIG. 10, then the amount of movement in the area 34 between the paddles 22, 27 due to the tension is further decreased, especially in the Z-direction, i.e. the direction perpendicular to the surface of the heart 1. Once the paddles 22, 27 are thus positioned and secured and the area of the tissue is temporarily immobilized, the coronary artery in that area may be operated upon.

In the preferred embodiment, the anastomosis of the coronary artery may be accomplished through any acceptable end-to-side or side-to-side technique. Of course, other methods of performing the anastomosis may be used, such as those methods which may be performed endoscopically.

FIG. 11 is an example of the motion in the plane parallel to the surface of the heart of a point on heart tissue during one half respiratory cycle when the heart is unrestrained and also depicting the motion of the same point on heart tissue when the suction devices are used. Line 60 is a tracing of the motion of a point of tissue on the cardiac surface. As seen by line 60, a point on the cardiac surface moves approximately 15 mm in each direction. Generally, each loop of movement depicts the motion of the beating heart within one cardiac cycle. Thus, loop 61 occurs due to one cardiac cycle.

Loop 62 occurs due to the next cardiac cycle, but the entire heart has shifted in location somewhat due to the inflation or deflation of the lungs associated with respiration. Line 63 shows the motion of the same point of heart tissue when the suction device is placed near the area and the heart wall is immobilized by the present invention. As seen, the present invention functions to minimize heart wall movement in that area to approximately 1 mm in each direction. This is best seen in FIG. 12 which is an enlarged portion of FIG. 11 and in particular line 63. As seen, through the use of the present invention, heart wall movement has been decreased to only slightly more than 1 mm. Decreased to an amount in the area of the suction devices such that the still-beating heart may be operated upon in that area using an endoscope or any other method of minimally invasive surgery.

FIG. 13 is an alternate embodiment of the present invention. As seen, the embodiment of FIG. 13 comprises a suction sleeve 80 which is coupled to an annular suction head 81 via a ball bearing joint 84. Ball bearing joint 84 may be provided so as to permit remote actuation of the suction head 81 from a position outside the chest. The suction head 81 has a series of suction ports 82 located along a first planar surface. In the embodiment shown the planar surface upon which the suction ports 82 are located is conical in shape, although other types of planar surface may be used, such as frusto-conical for example. The suction head 81 may be constructed such that each half of the device is coupled to a separate suction source. Through such a configuration, if one-half of the suction head 81 were to lose contact with the surface, the other one-half of the suction head 81 could maintain capture. The suction sleeve 80 is used as described above. That is the suction sleeve 80 itself is coupled to a suction source (not shown but the same as suction source 114) and is fixed or immobilized to a stationary point, such as the operating table or a retractor (also not shown.) Suction through the suction source and the suction sleeve 80 then causes the suction ports 82 to suck upon the heart tissue. Through this configuration, then, the heart tissue in the center of suction sleeve is immobilized. Interruption or opening 83 permits suction head 81 to be fixed to heart tissue while permitting a blood vessel to be grafted. In particular, if a mammary artery has been grafted end-to-side to a coronary artery, then the opening 83 permits the suction head 81 to be removed from around the grafted artery.

FIG. 14 is a view of the device being used to temporarily immobilize a local area of heart tissue using an alternative access procedure to the preferred mini-thoracotomy. In particular heart 1 is exposed with an incision 2 through the patient's sternum and the chest is spread apart by a retractor 3 to provide access to the heart 1. Access to the heart 1 is further effected by retraction of the pericardium 4 in the area of the heart 1 which is to be operated on. As shown pericardial retraction is accomplished through sutures 5.

As seen, the immobilizing device 11 comprises a pair of suction devices 12, 13 and a suction source 114. Suction devices 12, 13 are secured to patient by securing each to retractor 3 through a pair of clamps 19. Of course suction devices 12, 13 may also be secured to the operating table (not shown in this FIG. but using a securing device as described above.) Suction devices are coupled to suction source 114 through lines 20, 21. Suction source 114 is preferably the standard suction available in the operating room and coupled to the devices with a two liter buffer flask (not shown) for each device. Suction is provided at a negative pressure of between 200-600 mm Hg with 400 mm Hg preferred. As seen, each suction device has essentially two portions, a paddle 22 and an arm 23.

Turning now to FIG. 15 which is a side view of an alternate embodiment of suction device 12 showing its placement against the outline of a heart. As seen, the distal end of suction device comprises a paddle 22 and arm 23. Paddle 22 has a generally planar surface which conforms generally to the curvature of a heart 1, shown here in outline. The paddle 22 is coupled to arm 23 through a pin 24. The pin 24 permits the paddle 22 to be swiveled to the preferred angle relative to arm 23. As seen, arm 23 has a suction lumen 30 therethrough which communicates with a suction conduit 31 in paddle 22. Suction conduit 31, in turn, communicates through suction aperture 32 (best seen in FIG. 4) to suction port 33.

FIG. 16 is a view of the bottom of suction device 12 shown in FIG. 15. As seen, four suction ports 33 in a row are featured, although the specific or exact number and position used may vary.

FIG. 17 is a further alternate embodiment of a suction device 12 showing its placement against the outline of a heart. As seen, suction device 12 is substantially similar to that shown and described in FIG. 2, but for the addition of suture coil 73. Suture

coil 73 is a tightly wound spring fixed to the top surface of suction paddle 22. Further temporary stabilization of the coronary anastomosis site may be achieved, if desired, by catching epicardial flaps with light traction sutures. Suture coil 73 permits these and any other sutures to be temporarily fixed in place by wedging the suture between within suture coil 73, as is known in the art.

FIG. 18 is a bottom view of a further alternate embodiment of suction device 12. As seen, suction device 12 is substantially similar to that shown and described in FIG. 2, but for the addition of electrode 174 along a side of suction paddle 22. Electrode 174 is coupled by lead 175 to pulse generator 176. Electrode 174, lead 175 and pulse generator 176 may be provided according to well know methods and materials so as to permit the heart to be paced, cardioverted or defibrillated while suction device 12 is fixed to the surface of the heart.

FIG. 19 is a cross-sectional view of a body showing an alternate method of achieving access to a surface of the heart and using the present invention to immobilize an area of tissue. As seen suction device 12 is introduced through a first stab wound. As discussed above, suction arm 23 of device 12 is secured by securing device 14 to a stationary object, such as operating table 16. A second suction device may also be introduced through a second stab wound to securely immobilize a local area of tissue. Each suction device has a covering 180, made from latex rubber, over the distal end when it penetrates the chest wall in order to avoid blood and tissue from entering the suction ports and block suction apertures. Two or more additional surgical trocars 78 may be introduced to permit endoscopy and surgical access to heart 1. In addition the left lung 79 may also be partially collapsed so as to provide an unencumbered area in which to manipulate the surgical instruments.

FIG. 20A is a cross-sectional view of a body showing an alternate embodiment of the present invention, and in particular, an alternate embodiment of the securing device. In this embodiment, securing device comprises a pair of anchors 201, 202 which are attached to surgical table 203. As seen, surgical table is attached by pedestal 204 to the floor 205. Each anchor is attached on either side of the table using a pair of fasteners 206, 207. In the preferred embodiment, fasteners are a pair of screws which couple with longitudinal slots within each anchor to permit the anchors to be

adjusted both in an inward and outward direction as well as up and down, as shown by the arrows. As seen, anchors are designed to follow the contour of patient 210 to thereby provide a smooth surface over which a surgeon may operate. Each anchor is attached to retractor 3 by fasteners 211, 212. On the retractor 3 a mounting rail 999 is attached, best seen in FIG. 20B discussed below. Attached in turn to mounting rail is a pair of slip-grip type holders 12A, 13A or any other holder which permits an object to be quickly but securely mounted or removed, and mounted in turn to holders are a pair of suction devices 12B, 13B as has been already previously discussed above. In the preferred embodiment, each anchor is a strip of biocompatible metal, such as stainless steel, approximately 5-8 centimeters in width and 0.6 - 0.8 centimeters in thickness. As seen positioned at the bottom of anchors is a truss. In particular each anchor has fixed to it a descending member 216, 217, each of which are linked together by a pair of cross-braces 218, 219. Cross-braces may or may not be coupled together at their center points. As can be appreciated, through this truss construction the stability of anchors and thus the suction devices mounted thereto is increased.

FIG. 20B is a top view of the embodiment shown in FIG.20A. As seen, mounted to anchors 201, 202 is a mounting rail 999. In the preferred embodiment mounting rail is ellipsoidal in shape. As seen mounting rail is used to mount slip-grip type holders 12A, 13A and their corresponding suction devices. To be precise, mounting rail permits the suction devices to be securely mounted but yet be easily moved in the area of the surgical procedure. The ellipsoidal shape, moreover, corresponds more suitably to the surgical area. Of course, other shapes may also be used, such as circular, or non-symmetrical, for example. Of course other configurations of a mounting rail, retractor and anchor may be used, such as a retractor integral with the anchors or a mounting rail integral with the retractor or both, to mention only two of the many possibilities.

In use, access to the heart is achieved and retraction of the chest wall is performed prior to the positioning of the anchors. Once the heart access is achieved, the retractor is coupled to the anchors and the anchors are then fixed to the table. At this point, the retractor is thus immobilized with respect to the table and provides a stationary

object to which the immobilizing device featuring the a pair of suction devices 12B, 13B may be coupled.

FIGS. 21 and 22 depict a further alternate embodiment of the securing device. FIG. 21 is a perspective view of a securing device. As seen, in this embodiment, the securing device comprises a pair of formed rails 220, 221. As seen, each rail is coupled to the surgical table 203 through a series of screws 222, 223. Although not shown in the FIGS. each rail further features a truss-like structure such as that shown in FIG. 20 A which is positioned below the table which provides additional rigidity and stability. As seen, each rail is further formed to slope inwardly toward the patient 210 (shown in outline in this FIG.) This provides for access above the patient by the surgeon. Straddling between each rail is a mounting 224. The mounting is adjustable along the rail. The mountings are further designed to have a suction device mounted thereto. In such a manner, the mounting 224 and rails 220, 221 provide a stationary object to which the suction device may be mounted.

FIG. 22 depicts an overhead view of the rails 220, 221 used to position a suction device to the heart. As seen, in this embodiment, two suction devices 225, 226 are fastened to the mounting using a pair of slip-grip type holders 12A, 13A as already discussed above.

Turning now to FIG. 23 which is a side view of an alternate embodiment of suction device 12. As seen this alternate embodiment of suction device 12 features a suction port 33 as already described above. Each suction port is connected to a suction conduit 31 through a suction aperture 32 as also already described above. In this embodiment, however, the suction device further provides for the distribution of irrigation fluid onto the area of the heart where an anastomosis will be performed. As seen, the irrigation fluid source 133 is coupled by an irrigation line 134 to the irrigation fluid conduit 135. The irrigation fluid conduit, in turn, is coupled to an irrigation hose 136. As shown, irrigation hose is designed to have some flexibility to permit it to be rotated and moved along several angles and is preferably a braided stainless steel hose. Irrigation hose

dispenses irrigation fluid at its end. Irrigation fluid preferably is a warm saline mist which prevents the exposed tissues from drying out. Moreover, the fluid is dispensed under pressure such that the mist has a force to it which permits the mist to be used to blow with sufficient force to assist in holding open a coronary artery such that the anastomosis may be performed more easily. Suction device further features a return irrigation fluid circuit. As seen, return irrigation fluid circuit comprises a return irrigation port 140 which is coupled to a return irrigation conduit 141. Return irrigation conduit is coupled to a suction source to provide suction to return irrigation pipe 142 such that the irrigation fluid which is dispensed may be readily removed from the surgical area. Although shown as an integral part of the suction device, both the irrigation system as well as the suction system may or may not be a part of the suction device.

FIG. 24 is a further alternate embodiment of a suction device. As seen, suction device features the suction port, suction conduit and suction aperture as already described above. In this embodiment, however, the suction device further features an optical fiber 150 which is coupled at one end to the area of the suction device where the anastomosis will be performed and is further coupled to a light source 151. In this manner, the suction device may be used to provide additional light 152 to the area where the anastomosis will be performed.

FIG. 25 is a perspective view of an alternate embodiment of an immobilizing device 11. As seen, in this embodiment, each suction device is coupled to a mounting beam 998 through a pair of holders 12A, 13 A as already described above with reference to FIG. 20A. Mounting beam 998 features two sections, each of which may be individually rotated about or spread apart or both. In particular mounting beam has a central screw members 997, 996. Each central screw member has an actuating knob 994, 995 at an end thereof. Rotation of each knob thereby causes the suction device mounted to that portion of the mounting beam to move either away or towards the center of the mounting beam, as indicated by line 993. Mounting beam 998 is mounted to a stationary object, such as a retractor, mounting rail or fixation arm, through a central arm 992. Each suction device may further be rotated relative to the mounting beam through simply

moving each of the relevant devices, as indicated by the lines 991, 990. The use of mounting beam to retain suction devices is of use when only one fixation arm is to be used. In such a manner mounting beam permits both device to be fixed to a stationary object as well as permitting suction devices to be moved apart to thereby provide additional immobilization to a local area of tissue, as discussed above with regards to FIGS. 8-10.

FIG. 26A is a view of the bottom of an alternate embodiment of suction paddle 22 used in the immobilizing device. As seen, paddle has a series of suction ports, each of which is connected to suction conduit through a suction aperture. In this embodiment, the paddle features five suction ports. The additional side suction port is presented on the side of the suction paddle which will not be near the coronary artery or, in general, the surgical target. The additional port increases the suction surface area. Each suction port 33 has a 6 mm diameter while each suction aperture 32 has a 2 mm diameter.

FIG. 26B is a perspective view of the bottom of an alternate embodiment of suction paddle 22 used in the immobilizing device. As seen in this embodiment the paddle 22 is oriented at a ninety degree angle relative to the neck portion 71 and arm 23. Of course paddle may also be oriented at another suitable angle other than ninety degrees relative to neck portion. In this embodiment, the paddle features four suction ports, although more or less ports may also be provided. Each suction port 33 has a 6 mm diameter while each suction aperture 32 has a 2 mm diameter.

FIG. 27 is a perspective view of a turning handle 161 used to bend or orient the suction paddle 22 portion of the immobilizing device. As discussed above neck 71 is fashioned to be relatively bendable, as opposed to paddle 22 and arm 23. As seen, handle 161 features opening 980 having the same shape and dimension of paddle such that paddle may thus be inserted therein. Handle also features neck portion 982 and grip portion 981, Neck and grip portion are dimensioned to provide leverage against opening 980 and thus paddle, neck and arm. To use, paddle is inserted into opening. Once inserted manipulation of grip portion relative to arm causes bending in the area of neck. Such a

handle may be advantageous as compared to bending of the device by hand in that it avoids the surgeon from straining hand muscles which will be needed to perform delicate manipulations.

FIG. 28 is a bottom view of an alternate embodiment of immobilizing device 11. As seen, immobilizing device features a pair of suction paddles 171, 172, each of which is coupled to an arm by a continuous hinge or neck as discussed above. The arm in turn, is coupled to a stationary object, also discussed above. In this embodiment, the arms are further fastened together using a spreader 180. As seen, spreader 180 permits the arms to be moved relatively apart or together. As already discussed above, the movement of the arms apart is performed once the paddles are engaging by suction the surface of the heart to thereby increase epicardial tension locally and thus dampen or decrease the motion of the surface of the heart due to the intrinsic beating of the heart. Spreader also functions to provide additional stability to paddles due to its function as a truss-like member.

Turning to FIG. 29, spreader 180 comprises a pair of bars 181, 182 which are coupled together using a wing nut 183. One bar features an engagement pin 184 while the other bar features an engagement slot 185. Each bar is further coupled to each of the respective arms of the immobilizing device by a respective lumen 186, 187. In such a manner, each bar is securely coupled to each arm. By longitudinally manipulating each of the bars apart as shown by arrow 188, each arm and thus each paddle may be securely positioned relatively closer or further apart.

FIG. 30 depicts an alternate embodiment of spreader 180. As seen, spreader features a pair of bars which couple to each of the arms of a respective suction device, as described above. Bars are further coupled together using gearing 190. Gearing, in turn, is coupled to a motor 191. As seen, motor is further coupled to a power source 192. Coupling both motor and power source together is a control 193. Control automatically detects the amount of spread within the suction devices caused by spreader. In the preferred embodiment, control senses the amount of power or energy required by

motor to further spread spreader and thus suction paddles apart. When a threshold amount is reached, control shuts down the source of power for motor, thereby locking the spreader in the present position. The feature thus permits a spreader to automatically spread the suction paddles apart to a degree sufficient to dampen wall motion without permitting the spreader to spread paddles apart too much such that capture of the heart wall due to suction is lost. Of course, further designs to control the spreading of suction paddles may also be used, such as other mechanical or hydraulic actuated or controlled systems.

FIG. 31 depicts an alternate embodiment of immobilizing device and, in particular, an alternate embodiment of the securing device used to secure each suction paddle. As seen this system features a pair of arms 351, 351 having a ball and socket construction. As seen each arm features at its free end a slip and grip-type holder 12A and 13A as discussed above. The opposite end of each arm fits into a footing 970, 971. Each footing is lockable to a rail clamp unit 968, 969 which locks onto the rail 901, 902 at the side edges of table 203. Positioned at the bottom of rail clamp unit is locking actuator 967, 968. Each locking actuator cooperates within the arm to thereby cause the arm to be locked into position when the respective handle is turned in one of the directions indicated by arrows 965. In particular locking actuator causes a cable located with the respective arm to tighten, which, due to the ball and socket construction thereby causes the arm to be locked into position. Positioned at the bottom of each locking actuator is a truss. In particular each locking actuator has fixed to it a descending member 216, 217, each of which are linked together by a pair of cross-braces 218, 219. Cross-braces may or may not be coupled together at their center points. As can be appreciated, through this truss construction the stability of anchors and thus the suction devices mounted thereto is increased, as described earlier in FIG. 20A.

FIG. 32 is a cross sectional view of an arm shown in FIG. 31, and in particular showing a detail of the ball and socket construction. As seen only one portion is shown to illustrate the ball and socket construction. Each tube 800 (several of which are used to create arm) has its end fashioned to correspond to the shape of the ball 801, that is each relevant end of tube features a hemispherical hollow having a radius which

corresponds to the outer surface of the ball such that a larger portion of the tube contacts the ball as compared to if the end of the tube were only cut straight across. This geometry increases the surface area between the tube and each ball which thereby increases the stability of the arm when fixed into position. Each ball 801 further features an internal bushing 802. As seen each internal bushing is shaped to have a tapered opening 803 at each end. Positioned through the length of arm, and in particular within each tube element and ball is cable 804. Cable is preferably constructed from kevlar and features a polyurethane covering and is fastened to either end of the arm such that by tensioning the cable the ball and tube portions are brought together and fixed in relation due to friction. The operation of arm is as follows. When no tension is placed on the cable, each tube element may slip relatively easily relative to each ball. Tension on the cable, however, increases the friction between tube and ball. Sufficient tension thereby results in the ball and tube becoming immovable relative to each other. The taper 803 within each bushing 802 permits the cable to remain at the same length regardless of the orientation of each tube element and each ball. That is, if the arm is bent and has a radius of curvature, the taper permits the cable to remain at the same length regardless. This thus permits the arm to be more easily moved and thereafter locked into place.

FIG. 33 depicts a further alternate embodiment of the present invention, and in particular of a suction device substantially similar to that shown in FIG. 13 but for that two separate sets of suction ports are located at the top of the suction paddle. As seen each suction line has a stopcock 861, 862 to permit either or both sets of related suction ports to be independently disconnected from their respective suction source. Arm 823 contains lumens for each suction line and ends where necks 871, 872 begin, As discussed above, each neck is designed to bend. Suction paddle is mounted to necks and as seen features an encircling array of suction ports, located at the upper surface of the paddle relative to the arm. Suction paddle features sixteen suction ports, arranged as a set of eight along one side 81 coupled to one suction line and a second set of eight along another side 82 coupled to another suction line. Through this arrangement even if one side loses capture with the tissue, because the other side is coupled to another suction source, pressure is not lost on that side and capture in that area is maintained. In the embodiment shown the suction

ports are located along a generally conical planar surface at the top of the paddle, although other types of planar surfaces may be used, such as frusto-conical for example. The orientation of the suction ports along the top of the encircling paddle is most useful to access the posterior or backside of the heart so as to move or reposition the heart to achieve better access to areas which would otherwise be difficult to access.

To further assist in the exposure of the surgical site, access retractors may also be used in conjunction with the immobilizing device, such as spoon shaped probes to move other tissue from the area of surgical interest.

FIG. 34 depicts a further alternate embodiment of the present invention, and in particular of a suction device **12** that may be used in an endoscopic procedure featuring at its distal end an arm, i.e., suction arm **23**, and a pair of tissue engaging members, i.e., suction paddles **22**, each of which is coupled to a spreader means, i.e., spreader **180**. The distal end of suction device **12** is suitably configured for delivery through a small, percutaneous penetration, for example a small cut, incision, stab wound, hole, port, cannula, trocar sleeve or the like. The term "trocar sleeve" appearing herein also refers to cannulae and ports. Suction arm **23** of suction device **23** has a proximal end and a distal end. Although suction arm **23** is shown as having a circular cross-sectional shape, suction arm **23** may alternatively have a rectangular, triangular, oval or channel cross-sectional shape. As shown in **FIG. 34**, suction device **12** also features a handle **310** located at its proximal end. Suction device **12** may be coupled to a suction source **114** through suction line **20** (both not shown) to suction fitting **320** located on handle **310**. Suction paddles **22** may be rigidly coupled to spreader **180** at **330**, as seen in **FIG. 34**. Alternatively, suction paddles **22** may be rotatably or pivotably coupled to spreader **180** at **330**, thereby permitting suction paddles **22** to freely or controllably move or rotate relative to spreader **180**. Spreader **180** may be rigidly coupled to suction arm **23** at **340**. Alternatively, spreader may be rotatably or pivotably coupled to suction arm **23** at **340**, thereby permitting spreader **180** to freely or controllably move or rotate relative to suction arm **23**. As seen in **FIG. 34**, in this embodiment of the invention, spreader **180** may be controllably moved relative to suction arm **23** since spreader **180** is coupled to suction arm **23** via remotely actuatable linkage **350**. Actuator knob **360** on handle **310** is used to remotely and controllably actuate linkage **350**. Knob **360** is fixed to rod **370**. The proximal end of rod

370 is threaded at 380 so that rod 370 mates with a threaded inner bore (not shown) within handle 310. Rotation of knob 360 moves knob 360 and rod 370 in an axial direction with respect to suction arm 23.

As seen in FIGS. 35 and 36 which are longitudinal cross-sectional views of the distal end of suction device 12, linkage 350 comprises longitudinal rod 390 slidably disposed within suction arm 23 and a link 380 having a first and second ends 381, 382. The proximal end of rod 390 (not shown) is connected to the distal end of rod 370 within handle 310.

Linkage 350 further comprises a coupling member 383 which has a bifurcated proximal end with first and second coupling points 384 and 385. First end 381 of link 380 is coupled to the distal end of rod 390 and second end 382 of link 380 is coupled to coupling member 383 at coupling point 385. Suction arm 23 has an angled opening 400 (as seen in FIGS. 34, 35 and 36) at its distal end to allow spreader 180 to pivot into an orientation transverse to suction arm 23. Second coupling point 384 of coupling member 383 is pinned to distal end of suction arm 23 to form a pivot point 410. Spreader 180 which is connected to coupling member 383 will therefore pivot about a transverse axis through pivot point 410.

In the above described configuration, rotation of knob 360 moves rod 370 in an axial direction with respect to suction arm 23. Axial movement of rod 370 causes rod 390 to also move in an axial direction with respect to suction arm 23. Movement of rod 390 in the axial direction with respect to suction arm 23 controllably pivots spreader 180 and suction paddles 22 about pivot point 410, thereby allowing a surgeon to remotely control the orientation of suction paddles 22 relative to suction arm 23. Note that handle 310 may alternatively include another type of actuator mechanism to remotely control linkage 350, for example, a plunger mechanism, a pair of scissor-type handles, a lever mechanism, or a slidable button within a longitudinal slot. The actuator mechanism may be, for example, voice-activated comprising voice-recognition technologies. A visual and/or audible signal, such as a flashing light and/or beeping tone, may be incorporated to alert a surgeon to the completion or resumption of the actuator. Linkage 350 may be slaved to a robotic system which may include, for example, head-mounted displays which integrate 3-D visualization of surgical anatomy and related diagnostic and monitoring data, miniature

high resolution 2-D and 3-D digital cameras, a computer, a high power light source and a standard video monitor.

Referring again to **FIGS. 35** and **36**, suction paddles **22** are shown in this embodiment to comprise a series of three suction ports **33** each of which is connected in fluid communication to suction conduit **31** through suction aperture **32**. Note that the exact number, position and/or size of suction ports **33** may vary. Each suction conduit **31** is connected in fluid communication to suction lumen **30** located within suction arm **23** through a separate suction line **72**. Suction lumen **30** is connected in fluid communication to suction fitting **320** located on handle **310**. Therefore, when suction fitting **320** is connected to a suction source **114** through suction line **20** (both not shown), suction is created in suction ports **33**. Note that suction device **12** may include a suction controller, for example, handle **310** may include a suction controller (not shown) to control the amount of suction at suction ports **33**. Suction controller may be, for example, a valve. Suction controller may also be, for example, voice-activated comprising voice-recognition technologies. A visual and/or audible signal, such as a flashing light and/or beeping tone, may be incorporated to alert a surgeon to the completion or resumption of suction. Suction controller may be slaved to a robotic system which may include, for example, head-mounted displays which integrate 3-D visualization of surgical anatomy and related diagnostic and monitoring data, miniature high resolution 2-D and 3-D digital cameras, a computer, a high power light source and a standard video monitor.

In this embodiment, suction paddles **22**, suction ports **33**, suction apertures **32** and suction conduits **31** are all generally similar to those previously described. Suction device **12** may be constructed such that each suction paddle **22** and/or each suction port **33** is coupled to a separate suction source allowing them to be independently disconnected from their respective suction source or suction device **12** may be constructed such that each suction paddle **22** and/or each suction port **33** is coupled to the same suction source, as described in this embodiment.

In **FIGS. 35** and **36**, suction paddles **22** are shown to have a surface which contacts a heart slightly curved such that the surface will conform generally to the curvature of the heart. Heart contacting surfaces of suction paddles **22** may also be generally planar. The heart contacting surfaces of suction paddles **22** may have a separate contact layer to cushion the

contact between the paddles and the heart tissue and to facilitate forming a tight seal when suction is applied. The contact layer may cover substantially the entire bottom surface proximate to the openings of the suction ports. The contact layer may comprise of one or more materials, for example, commercially available polymers, such as silicon or polyurethane, which are pliable and biocompatible may be used. In addition, one or more radioactive materials and/or biological agents such as, for example, an anticoagulant agent, an antithrombotic agent, a clotting agent, a platelet agent, an anti-inflammatory agent, an antibody, an antigen, an immunoglobulin, a defense agent, an enzyme, a hormone, a growth factor, a neurotransmitter, a cytokine, a blood agent, a regulatory agent, a transport agent, a fibrous agent, a protein, a peptide, a proteoglycan, a toxin, an antibiotic agent, an antibacterial agent, an antimicrobial agent, a bacterial agent or component, hyaluronic acid, a polysaccharide, a carbohydrate, a fatty acid, a catalyst, a drug, a vitamin, a DNA segment, a RNA segment, a nucleic acid, a lectin, an antiviral agent, a viral agent or component, a genetic agent, a ligand and a dye (which acts as a biological ligand) may also be used.

It should be understood that suction paddles **22**, i.e., tissue engaging members, may comprise a variety of shapes and configurations so long as they have a relatively rigid portion with a contact or coupling surface suitable for engaging tissue. In fact, in this embodiment of suction device **12** comprising spreader means **180**, friction paddles may be used in place of suction paddles. Friction paddles may also be rigidly, rotatably or pivotably coupled to spreader **180**. Friction paddles may have a contact or coupling surface suitable for engaging tissue frictionally, for example, the contact surface may comprise a rough surface. Further, in this embodiment of suction device **12** comprising spreader **180**, adhesive paddles may be used in place of suction paddles. Adhesive paddles may also be rigidly, rotatably or pivotably coupled to spreader **180**. Adhesive paddles may have a contact or coupling surface suitable for engaging tissue adhesively, for example, the contact surface may comprise a tissue adhesive.

FIG. 37 is a bottom view of spreader **180** with coupled suction paddles **22** in a non-spread position, whereas **FIG. 38** is a bottom view of spreader **180** with coupled suction paddles **22** in a spread position. As seen in **FIGS. 37** and **38**, in this embodiment of the invention, suction paddles **22** are attached to spreader **180** such that suction paddles **22** are oriented

parallel to each other. Cable 430 extends between spreader 180 and handle 310 through suction arm 23. The proximal end of cable 430 is connected to actuator lever 420 on handle 310. The distal end of cable 430 is connected to spreader 180. Lever 420 is used to remotely and controllably actuate spreader 180 as described below.

As shown in FIGS. 37 and 38, cable 430 passes through anchor 440 and is coupled to slide 450 which is slidably coupled to anchor 440. Cable 430 may be made of stainless steel. Referring to FIGS. 39 and 40, plan views of spreader members 460, 470 are shown with a suction paddle 22 rigidly coupled to each at 330. As previously discussed, suction paddles 22 may be rigidly coupled to spreader members 460, 470 at 330 or, alternatively, suction paddles 22 may be rotatably or pivotably coupled to spreader members 460, 470 at 330, thereby permitting suction paddles 22 to move or rotate relative to spreader members 460, 470. Spreader members 460, 470 include first, second and third slots 471, 472, 473 with the second slot 472 being oriented substantially perpendicular to the suction paddles 22. The second slot 472 of spreader members 460, 470 are aligned so that a pin passing through the second slots 472 helps maintain suction paddles 22 parallel to one another throughout movement between a non-spread and a spread position. The first and third slots 471, 473 of each of spreader members 460, 470 are parallel to one another and oriented 45 degrees relative to the suction paddles 22. Referring to FIG. 37, first, second and third pins 475, 476, 477 pass through the first, second and third slots 471, 472, 473. Referring to FIGS. 41 and 42, side and plan views of slide 450 are shown. Slide 450 includes throughhole 480 for receiving cable 430. The distal end of cable 430 preferably has an anchor (not shown) which prevents withdrawal of cable 430 through throughhole 480. Slide 450 includes first and second holes 481, 482 extending through first and second sides 483, 484. The first and third pins 475, 477 extend through first and second holes 481, 482 of slide 450 and first and third slots 471, 473 of spreader members 460, 470 for moving spreader members 460, 470 when slide 450 is moved. Slide 450 also includes grooves 490 extending between the first and second holes 481, 482. Referring to FIGS. 43 and 44, side and plan views of anchor 440 are shown. Anchor 440 includes central guides 500 which are positioned in grooves 490 of slide 450. Central guides 500 and grooves 490 cooperate to help maintain the linearly slidably relationship between slide 450 and anchor 440. Central guides 500 also include holes 501

therethrough for receiving the second pin 476 which extends through second slots 472 in spreader members 460, 470. Anchor 440 includes throughhole 502 for receiving cable 430. Proximal end 510 of anchor 440 includes four arms 515, three of which are shown in FIGS. 43 and 44, which extend between central guides 500 and proximal end 510.

Referring again to FIG. 35, anchor 440 of spreader 180 is connected to coupling member 383 of linkage 350.

Referring to FIGS. 34 and 45, actuation of lever 420, comprising a slidable member 600 within a longitudinal slot 610 in handle 310, controllably moves cable 430 and slide 450 proximally relative to suction arm 23. Cable 430 is connected to the end of slidable member 600 within handle 310. Actuation of lever 420 causes the slidable member 600 to move cable 430 and slide 450 proximally relative to suction arm 23. Movement of cable 430 and slide 450 in a proximal direction relative to suction arm 23 moves suction paddles 22 into a non-spread position as shown in FIGS. 37 and 45. The pin and slot configuration of spreader members 460, 470, slide 450 and anchor 440 cause spreader members 460, 470 to move suction paddles 22 parallel to one another as shown in FIGS. 34 and 38. Lever 420 includes a spring (not shown) to provide a biasing force to keep lever 420 in a non-actuated position and suction paddles 22 in a spread position as shown in FIG 34.

Although, in this embodiment both suction paddles 22 are seen movable between the non-spread position of FIG. 37 and the spread position of FIG.38, spreader 180 may also be configured with only one suction paddle 22 being movable. In addition, handle 310 may alternatively include another type of actuator mechanism to remotely control spreader 180, for example, a knob, a plunger mechanism, a pair of scissor-type handles, or a slidable button within a longitudinal slot. The actuator mechanism may be, for example, voice-activated comprising voice-recognition technologies. A visual and/or audible signal, such as a flashing light and/or beeping tone, may be incorporated to alert a surgeon to the completion or resumption of the actuator. Spreader 180 may be slaved to a robotic system which may include, for example, head-mounted displays which integrate 3-D visualization of surgical anatomy and related diagnostic and monitoring data, miniature high resolution 2-D and 3-D digital cameras, a computer, a high power light source and a standard video monitor. As previously discussed, spreader 180 may be coupled to gearing, which in turn,

is coupled to a motor. The motor is further coupled to a power source. The motor and power source which may be used together are coupled to a controller which detects and controls the amount of spread or area between the suction paddles. Of course, further designs to control the spreading of suction paddles may also be used, such as other mechanical or hydraulic activated or controlled systems.

In **FIG. 46**, an alternate embodiment of suction device **12** is shown. In this embodiment, the distal end of suction arm **23** comprises two remotely actuated variable linkages or joints, as seen linkage **350** and joint **800**. Suction arm **23** may include, for example, a plurality of remotely actuatable variable joints such as elbows, wrists, hinges, linkages and/or ball and sockets, as is well known in the art. See for example, U.S. Pat. No. 5,374,277 of Hassler, again incorporated herein by reference. **FIG. 47** is a side view of joint **800**. As seen in **FIG. 46** and **47**, joint **800** pivots at pivot point **810** which may comprise a pin. Joint **800** may be remotely actuatable via cables (not shown) extending between joint **800** and handle **310** (not shown) through suction arm **23**. The distal end of the cables would be connected to joint **800**. The proximal end of the cables would be connected to an actuator mechanism (not shown) on arm or handle. The actuator mechanism used to remotely control joint **800** may be, for example, a knob, a lever mechanism, a plunger mechanism, a pair of scissor-type handles, or a slidable button within a longitudinal slot. The actuator mechanism may be, for example, voice-activated comprising voice-recognition technologies. A visual and/or audible signal, such as a flashing light and/or beeping tone, may be incorporated to alert a surgeon to the completion or resumption of the actuator. Joint **800** may be slaved to a robotic system which may include, for example, head-mounted displays which integrate 3-D visualization of surgical anatomy and related diagnostic and monitoring data, miniature high resolution 2-D and 3-D digital cameras, a computer, a high power light source and a standard video monitor.

As described earlier, suction device **12** may include additional features, for example, an irrigation means for providing a distribution of irrigation fluid onto the area of the heart where the surgical procedure will be performed. Suction device **12** may feature a light means to provide light to where the surgical procedure will be performed, for example, via an optical fiber coupled to a remote light source. Suction device **12** may feature a suture

securing or retaining means, such as a suture coil or a plurality of slots formed in the upper surfaces of suction paddles 22. Suction device 12 may feature one or more electrodes, a cutting means or a visual means.

FIG. 48 is a cross-sectional view of a body showing one method of achieving access to a surface of the heart and using the present invention to immobilize an area of tissue. As seen suction device 12 is sized to fit appropriately within a trocar sleeve. Preferably the trocar sleeve has an internal diameter of about 15 mm or less. In addition, suction device 12 has a length selected to reach a target site, such as a heart or other organ, in a body cavity, such as the thoracic cavity or abdomen, and to extend sufficiently out of the body cavity to facilitate easy manipulation and securing of the device. A trocar sleeve, port or cannula may be positioned in a percutaneous intercostal penetration. Suction device 12 may be sized appropriately to be introduced through a small cut, incision, stab wound, hole, port, cannula, trocar sleeve or the like, for example, through the chest wall between two adjacent ribs which does not require cutting, removing, or significantly, displacing or retracting the ribs or sternum. Usually, a percutaneous intercostal penetration will require a puncture or incision of less than about 5 cm in length. Additional ports, cannulae or surgical trocars may be introduced to permit additional suction devices to be introduced or to permit endoscopy and surgical access to heart 1. Usually, trocar sleeves will be positioned within intercostal spaces in the left lateral chest of the patient, generally within the second, third, fourth, fifth, sixth or seventh intercostal spaces. In addition the left lung 79 may be partially collapsed so as to provide an unencumbered area in which to manipulate surgical instruments.

To introduce this embodiment of suction device 12 through a small cut, incision, stab wound, hole, port, cannula or trocar sleeve or the like, a surgeon would first use actuator knob 360 on handle 310 to pivot suction paddles 22 about a transverse axis so that the paddles are oriented generally parallel to suction arm 23. Next, the surgeon would fully actuate lever 420 on handle 310, as shown in **FIG. 45**, thereby causing spreader 180 to move suction paddles 22 together into a fully non-spread position. The distal end of suction device 12, including suction paddles 22 and spreader 180, may then be introduced into the body cavity such as the chest through, for example a trocar sleeve as shown in **FIG. 48**. After suction paddles 22 and spreader 180 have passed through a trocar sleeve

78 and into the body cavity, spreader 180 may be actuated to allow suction paddles 22 to partially or fully spread apart in a parallel orientation to each other, thereby creating a gap between suction paddles 22. If additional spreading of suction paddles 22 is desired following their engagement to heart tissue then spreader 180 may be partially actuated at this time. If no additional spreading of suction paddles 22 is desired following their engagement to heart tissue then spreader 180 may be allowed to fully spread suction paddles 22, as shown in FIG. 34, at this time.

After suction paddles 22 and spreader 180 have passed into the body cavity and suction paddles 22 have been partially or fully spread apart, a surgeon may use actuator knob 360 on handle 310 to pivot suction paddles 22 about a transverse axis (see FIGS. 35 and 36) so that their contact surfaces are oriented generally parallel to the area in which temporary immobilization of the heart tissue is desired. For example, the surgeon may pivot the paddles upwards with respect to suction arm (see FIG. 35) and push suction device in the distal direction to place at least portions of paddles against the heart surface. If the tissue surface has a different orientation, e.g., facing away from the surgeon, the surgeon may pivot the paddles downwards (see FIG. 36) with respect to suction arm and pull suction device in the proximal direction to place at least portions of paddles against the heart surface. Alternatively, a surgeon may change the orientation of the paddles prior to spreading of the paddles.

Suction paddles generally are placed in the area in which temporary immobilization of the heart tissue is desired. When used for a coronary artery bypass graft procedure, suction paddles are generally placed such that the target coronary artery is positioned between the paddles, i.e., one paddle is placed on each side of the artery. Once suction paddles are placed, suction is then created in suction ports. Through the suction, the device then is fixed to or grabs hold of the heart tissue. Once the suction is created and the paddles are secured to the heart tissue, the paddles may again be spread slightly further apart if they had been only partially spread prior to placement. The effect of this further spreading in a parallel orientation after the paddles have been secured or engaged to the heart tissue is to cause an even tension to be created in the area of the heart tissue between the paddles. This increase in epicardial tension further immobilizes the area by dampening or decreasing the motion due to the intrinsic beating of the heart in the area of

the heart tissue between the paddles. In addition, the spreading apart of paddles after they have been secured or engaged to the heart tissue helps to increase exposure of the target coronary artery.

If friction paddles are used instead of suction paddles, once paddles have been placed, for example, on each side of the target coronary artery, a force may be used to engage friction paddles to the heart tissue as opposed to using suction to engage suction paddles to the heart tissue. Once friction paddles have been secured or engaged to the heart tissue they may be further spread as discussed above.

Referring again to **FIG. 48**, once paddles **22** are suitably positioned and engaged to the heart tissue, suction device **12** may be clamped or secured by a securing device **14** to a stationary object or stable support, such as operating table **16** to fix the position of suction arm **23** relative to the beating heart. Alternatively, suction device **12** may be secured to a mounting rail **999** or a mounting **224** as discussed previously or to a stationary rib retractor, trocar sleeve, cannula or port that is fixed to the patient's chest and does not move relative to the beating heart. For example, suction device **12** may be introduced through a locking cannula or trocar sleeve that is fixed to a patient's chest and that will clamp onto suction device **12**, thereby securing its position with respect to the beating heart. Suction device **12** may be secured to a stable object using a variety of methods, for example, a clamp, a screw, a wing nut, a slip and grip-type holder or a lockable footing which in turn locks onto a rail. Slip and grip-type holders and lockable footings are previously discussed.

Once the paddles are suitably secured, positioned and engaged to the heart tissue thereby temporarily immobilizing the area of tissue, the coronary artery in that area, for example, may be operated upon. The anastomosis of the coronary artery may be accomplished through any acceptable end-to-end, end-to-side or side-to-side technique, for example manual suturing. In addition, other methods of performing the anastomosis may be used, for example, tissue-bonding techniques such as tissue adhesives and laser welding of tissue may be used. Mechanical anastomotic devices including stapling devices, clipping devices, ring and pin coupling devices and suturing devices may also be used. These anastomotic devices may be automated or semi-automated. Mechanical couplers including stents, ferrules, and/or rings may also be used to form an anastomosis.

Materials used to form an anastomosis via a mechanical device and/or coupler may be biocompatible, bioabsorbable, bioactive and/or bioinert. Following completion of the surgical procedure, e.g., the anastomosis, the paddles are disengaged from the heart surface, positioned in a non-spread configuration and aligned with arm, see **FIG. 45**. The suction device is unsecured from the stationary object and removed from the patient's body.

It should be understood that the present invention may be used in conjunction with a conventional thoracotomy and in various surgical procedures including throscopic, laparoscopic, and arthroscopic procedures as well as in conventional open heart surgical procedures. The invention is also useful for repositioning an organ in a body cavity to facilitate a surgical procedure. As discussed earlier, a suction device comprising a remotely controllable spreader means is particularly useful in minimally-invasive and endoscopic procedures.

FIG. 49 depicts a further alternate embodiment of the present invention, and in particular of a suction device that may be used in an endoscopic procedure, as described earlier, featuring at its distal end a suction arm **23** and a pair of suction paddles **22**, each of which is coupled to a spreader **180**. The distal end of the suction device is suitably configured for delivery through a small, percutaneous penetration, for example a small cut, incision, stab wound, hole, port, cannula, trocar sleeve or the like. Suction arm **23** of the suction device has a proximal end (not shown) and a distal end (as shown in **FIGS. 49, 50** and **51**). In this embodiment suction arm **23** has a circular cross-sectional shape, however suction arm **23** may alternatively have a rectangular, triangular, oval or channel cross-sectional shape. The suction device may feature a handle (not shown) located at the proximal end of suction arm **23**. As previously discussed, the suction device may be coupled to a suction source through a suction line to a suction fitting located on the arm or handle. For an example of a suitable suction device handle, see **FIG. 34**. Referring again to **FIGS. 49, 50** and **51**, suction paddles **22** are shown pivotably coupled to spreader **180** at pivot points **901, 902, 903** and **904**, each comprising pins.

Spreader **180** may be rigidly coupled to suction arm **23** at **340**. Alternatively, spreader may be rotatably or pivotably coupled to suction arm **23** at **340**, thereby permitting spreader **180** to freely or controllably move or rotate relative to suction arm **23**. As seen in

FIG. 49, in this embodiment of the invention, spreader **180** may be controllably moved relative to suction arm **23** since spreader **180** is coupled to suction arm **23** via remotely actuatable joint **800**. In this embodiment, the distal end of suction arm **23** is shown to comprise one remotely actuated linkage or joint **800**. However, suction arm **23** may include, for example, a plurality of remotely actuatable variable joints, elbows, wrists, hinges, linkages and/or ball and sockets, as is well known in the art. See for example, U.S. Pat. No. 5,374,277 of Hassler, again incorporated herein by reference. **FIG. 47** is a side view of joint **800**. As seen in **FIG. 47, 49, 50** and **51**, joint **800** pivots at pivot point **810** which may comprise a pin. Joint **800** may be remotely actuatable via cables (not shown) extending between joint **800** and a handle (not shown) through suction arm **23**. The distal end of the cables would be connected to joint **800**. The proximal end of the cables would be connected to an actuator mechanism (not shown) on the arm or handle. The actuator mechanism used to remotely control joint **800** may be, for example, a knob, a lever mechanism, a plunger mechanism, a pair of scissor-type handles, or a slidable button within a longitudinal slot in handle. The actuator mechanism may be, for example, voice-activated comprising voice-recognition technologies. A visual and/or audible signal, such as a flashing light and/or beeping tone, may be incorporated to alert a surgeon to the completion or resumption of the actuator. Joint **800** may be slaved to a robotic system which may include, for example, head-mounted displays which integrate 3-D visualization of surgical anatomy and related diagnostic and monitoring data, miniature high resolution 2-D and 3-D digital cameras, a computer, a high power light source and a standard video monitor.

Suction paddles **22** in this embodiment comprise a series of two suction ports each of which is connected in fluid communication to a suction conduit through suction aperture (not shown). Note that the exact number, position and/or size of suction ports may vary. Each suction conduit is connected in fluid communication to a suction lumen (not shown) located within suction arm **23** through a separate suction line (not shown). The suction lumen within arm **23** would be connected in fluid communication to a suction fitting located on the arm or handle (both not shown). Therefore, when the suction fitting is connected to a suction source through a suction line (both not shown), suction would be created in the suction ports. Note that the suction device may include a suction controller

to control the amount of suction at the suction ports. Suction controller may be, for example, a valve. Suction controller may also be, for example, voice-activated comprising voice-recognition technologies. A visual and/or audible signal, such as a flashing light and/or beeping tone, may be incorporated to alert a surgeon to the completion or resumption of suction. Suction controller may be slaved to a robotic system which may include, for example, head-mounted displays which integrate 3-D visualization of surgical anatomy and related diagnostic and monitoring data, miniature high resolution 2-D and 3-D digital cameras, a computer, a high power light source and a standard video monitor. In this embodiment, suction paddles, suction ports, suction apertures and suction conduits are all generally similar to those previously described. In addition, the suction device may be constructed such that each suction paddle and/or each suction port is coupled to a separate suction source allowing them to be independently disconnected from their respective suction source or the suction device may be constructed such that each suction paddle and/or each suction port is coupled to the same suction source, as described in this embodiment.

FIG. 49 is a top view of spreader **180** with coupled suction paddles **22** in a non-spread position, whereas **FIG. 50** and **51** are top views of spreader **180** with coupled suction paddles **22** in a partially spread position and a fully spread position, respectively. As seen in **FIGS. 49, 50** and **51**, in this embodiment of the invention, suction paddles **22** are attached to spreader **180** such that suction paddles **22** are oriented generally parallel to each other. A cable (not shown) would extend between spreader **180** and an actuator mechanism located at the proximal end of suction arm **23**. The proximal end of the cable would be connected to an actuator mechanism located on the arm or handle. The distal end of cable would be connected to spreader **180**. An actuator mechanism may be used to remotely and controllably actuate spreader **180**.

The actuator mechanism may be, for example, a knob, a lever mechanism, a plunger mechanism, a pair of scissor-type handles, or a slidable button within a longitudinal slot in handle. The actuator mechanism may be, for example, voice-activated comprising voice-recognition technologies. A visual and/or audible signal, such as a flashing light and/or beeping tone, may be incorporated to alert a surgeon to the completion or resumption of the actuator. Spreader **180** may be slaved to a robotic system which may include, for

example, head-mounted displays which integrate 3-D visualization of surgical anatomy and related diagnostic and monitoring data, miniature high resolution 2-D and 3-D digital cameras, a computer, a high power light source and a standard video monitor.

The cable (not shown) may be made of stainless steel. The distal end of the cable would be attached to spreader member 915 of spreader 180. Spreader member 915 is pivotably coupled to suction paddles 22 at pivot points 901, 904. Spreader member 915 also comprises a pin at 910 that fits slidably into longitudinal slot 921 of anchor member 920. Anchor member 920 of spreader 180 is pivotably coupled to suction paddles 22 at pivot points 902, 903. Anchor member 920 is also coupled to joint 800 at 340.

As shown in FIGS. 49, 50 and 51, spreader 180 maintains suction paddles 22 parallel to one another throughout movement between a non-spread and a spread position.

Controllably moving spreader member 915 distally relative to anchor member 920, for example via a cable, will move suction paddles into a non-spread position as shown in FIG. 49. Controllably moving spreader member 915 proximally relative to anchor member 920 will move suction paddles into a fully spread position as shown in FIG. 51. The pin and slot configuration of spreader member 915 and anchor member 920 allows spreader 180 to controllably move suction paddles 22 parallel to one another as shown in FIGS. 49, 50 and 51. In addition, handle 310 may alternatively include another type of actuator mechanism to remotely control spreader 180, for example, a knob or a plunger. Although, in this embodiment both suction paddles 22 are seen movable between the non-spread position of FIG. 49 and the spread position of FIG. 51, spreader 180 may also be configured with only one suction paddle 22 being movable. A spreader 180 wherein only one suction paddle moves relative to the other is shown in FIGS. 52 and 53.

Another embodiment of the distal end of suction arm 23, is shown in FIGS. 52 and 53. The distal end of suction arm 23 comprises two remotely actuated variable joints 800 which pivot about pins at pivot points 810. Joints 800 may be remotely actuatable via cables (not shown) extending between joints 800 and a handle (not shown) through suction arm 23. The distal end of the cables would be connected to joints 800. The proximal end of the cables would be connected to one or more actuator mechanisms (not shown) on the arm or handle. The actuator mechanism used to remotely control a joint 800 may be, for example, a knob, a lever mechanism, a plunger mechanism, a pair of

scissor-type handles, or a slidable button within a longitudinal slot in handle. The actuator mechanism may be, for example, voice-activated comprising voice-recognition technologies. A visual and/or audible signal, such as a flashing light and/or beeping tone, may be incorporated to alert a surgeon to the completion or resumption of the actuator. Joint **800** may be slaved to a robotic system which may include, for example, head-mounted displays which integrate 3-D visualization of surgical anatomy and related diagnostic and monitoring data, miniature high resolution 2-D and 3-D digital cameras, a computer, a high power light source and a standard video monitor. Joint **800** may be locked into position, for example, via tube **802** located within arm **23**. Pushing tube **802** distally against joint **800**, thereby applying pressure to joint **800**, locks joint **800** into position. The actuator mechanism used to remotely control the movement of tube **802** may be, for example, a knob, a lever mechanism, a plunger mechanism, a pair of scissor-type handles, or a slidable button within a longitudinal slot in handle. In addition, tube **802** may be used as a suction lumen located within suction arm **23** for providing suction to suction ports **33**.

As shown in **FIGS. 52** and **53**, suction paddles **22** are shown rigidly coupled to spreader **180** at **330**. Spreader **180** may be controllably moved relative to suction arm **23** since spreader **180** is coupled to suction arm **23** via the two remotely actuatable joints **800**. **FIG. 52** is a top view of spreader **180** with coupled suction paddles **22** in a non-spread position, whereas **FIG. 53** is a top view of spreader **180** with coupled suction paddles in a fully spread position. In this embodiment of the invention, suction paddles **22** are attached to spreader **180** such that suction paddles **22** are oriented generally parallel to each other. Cable **931** extends between spreader **180** and an actuator mechanism (not shown) that would be located at the proximal end of suction arm **23**. The proximal end of the cable would be connected to an actuator mechanism located on the arm or handle. The distal end of cable is connected to spreader **180**. An actuator mechanism may be used to remotely and controllably actuate spreader **180**.

Cable **931** may be made of stainless steel. The distal end of the cable would be attached to spreader member **950** of spreader **180**. Spreader member **950** is pivotably coupled to the distal end of spreader member **932** at pivot point **936** and to the distal end of spreader member **933** at pivot point **937**. The proximal end of spreader member **932** is pivotably

coupled to spreader member 951 at pivot point 934. The adjacent sides of spreader members 932 and 933 may be designed to engage or interlock with one another when they are in direct contact, for example when spreader is in a spread position. Spreader member 932, for example, may include a groove or slot that spreader member 933 will fit or slide into. The interlocking of spreader members 932 and 933 provides increased strength. The proximal end of spreader member 933 is pivotably coupled to spreader member 951 at pivot point 935. Spreader member 951 is coupled to the most distal joint 800 of suction arm 23. Spreader 180 may include a spring to provide a biasing force to position suction paddles in a non-spread, overlapping position as shown in FIG 52 when spreader 180 is not actuated. Moving cable 931 in a proximal position relative to suction arm 23 will force suction paddles into a parallel spread position as shown in FIG. 53.

The actuator mechanism for remotely controlling spreader 180 may be, for example, a knob, a lever mechanism, a plunger mechanism, a pair of scissor-type handles, or a slidable button within a longitudinal slot. The actuator mechanism may be, for example, voice-activated comprising voice-recognition technologies. A visual and/or audible signal, such as a flashing light and/or beeping tone, may be incorporated to alert a surgeon to the completion or resumption of the actuator. Spreader 180 may be slaved to a robotic system which may include, for example, head-mounted displays which integrate 3-D visualization of surgical anatomy and related diagnostic and monitoring data, miniature high resolution 2-D and 3-D digital cameras, a computer, a high power light source and a standard video monitor. As previously discussed, spreader 180 may be coupled to gearing, which in turn, is coupled to a motor. The motor is further coupled to a power source. The motor and power source which may be used together are coupled to a controller which detects and controls the amount of spread or area between the suction paddles. Of course, further designs to control the spreading of suction paddles may also be used, such as other mechanical or hydraulic activated or controlled systems.

Another embodiment of suction arm 23, is shown in FIGS. 54 and 55. At least a portion of suction arm 23 comprises a plurality of flexible, lockable interconnecting links thereby allowing it to be positioned in every direction until the desired configuration is achieved at which point the flexible arm may be locked into a fixed configuration by an actuator mechanism attached to the proximal end of cable 965. Cable 965 runs axially through the

interconnecting links of suction arm 23 and is coupled to spreader 180. FIG. 54 is a bottom view of spreader 180 with coupled suction paddles 22 in a non-spread position, whereas FIG. 55 is a bottom view of spreader 180 with coupled suction paddles in a fully spread position. In this embodiment of the invention, suction paddles 22 are attached to spreader 180 such that suction paddles 22 are oriented generally parallel to each other. Cable 936 extends between spreader 180 and an actuator mechanism (not shown) that would be located at the proximal end of suction arm 23. The proximal end of the cable would be connected to an actuator mechanism located on the arm or handle. An actuator mechanism is used to remotely and controllably actuate spreader 180. The actuator mechanism may be, for example, a knob, a lever mechanism, a plunger mechanism, a pair of scissor-type handles, or a slidable button within a longitudinal slot in handle. The actuator mechanism may be, for example, voice-activated comprising voice-recognition technologies. A visual and/or audible signal, such as a flashing light and/or beeping tone, may be incorporated to alert a surgeon to the completion or resumption of the actuator. Spreader 180 may be slaved to a robotic system which may include, for example, head-mounted displays which integrate 3-D visualization of surgical anatomy and related diagnostic and monitoring data, miniature high resolution 2-D and 3-D digital cameras, a computer, a high power light source and a standard video monitor.

The distal end of cable 965 is connected to spreader 180. The cable may be made of stainless steel. The distal end of cable 965 is anchored to slide 960 of spreader 180 using cable anchor 966. The distal end of slide 960 is pivotably coupled to the proximal ends of spreader members 963, 964, 965, 966 at pivot points 967, 968 both comprising pins. The distal ends of spreader members 963, 964, 965, 966 are, in turn, pivotably coupled to suction paddles 22 at pivot points 969, 970, 971, 972 which all comprise pins. The adjacent sides of spreader members 963 and 964 may be designed to engage or interlock with one another when they are in direct contact, for example when spreader is in a spread position. Spreader member 963, for example, may include a groove or slot that spreader member 964 will fit or slide into. The interlocking of spreader members 963 and 964 provides increased strength. The adjacent sides of spreader members 965 and 966 may also be designed to engage or interlock with one another when they are in direct contact again, for example when spreader is in a spread position. Spreader member 965, for

example, may include a groove or slot that spreader member 966 will fit or slide into. The interlocking of spreader members 965 and 966 provides increased strength. Slide 960 is slidably coupled to anchor 961. Slide 960 is also slidably coupled to wedge 973. Wedge 973 is rigidly coupled to anchor 961 via spreader member 962.

When no tension is placed on cable 965 attached to spreader 180 and running through the length of suction arm 23, the paddles are in a non-spread, overlapping position, as shown in FIG. 54, and the arm is relatively flexible within the region of the interconnecting links. It is in this configuration that the suction device is suitable for endoscopic delivery as discussed previously, for example through a trocar access. The arm may comprise cables for remotely controlling its orientation. Following endoscopic delivery, tension is applied to cable 965, i.e., the cable moves proximally relative to suction arm 23, causing the paddles to spread apart in a parallel orientation as shown in FIG. 55. The distance between suction paddles 22 is controllable by the movement of cable 965. Once the paddles have been generally placed in the area in which temporary immobilization of the heart tissue is desired, suction is applied to secure the paddles to the heart tissue. Once suction is created and the paddles are secured to the heart tissue, the paddles are again spread slightly further apart in a parallel orientation by moving or pulling the cable further in the proximal direction which also locks the arm in place. The further spreading of the paddles after the paddles have been secured or engaged to the heart tissue is to cause an even tension to be created in the area of the heart tissue between the paddles. This increase in epicardial tension further immobilizes the area by dampening or decreasing the motion due to the intrinsic beating of the heart in the area of the heart tissue between the paddles. In addition, the spreading apart of paddles after they have been secured or engaged to the heart tissue helps to increase exposure of the target coronary artery.

Referring again to FIGS. 54 and 55, suction paddles 22 are shown in this embodiment to comprise a two suction ports 33 each of which is connected in fluid communication to a suction conduit through a suction aperture (both not shown). Note that the exact number, position and/or size of suction ports 33 may vary. Each suction conduit is connected in fluid communication to a suction line 72 which, in this embodiment, is shown to run along the outer surface of suction arm 23. Therefore, when suction lines 72 are connected to a suction source (not shown), suction is created in suction ports 33. Note that the suction

device may include a suction controller, for example, a valve. Suction controller may also be, for example, voice-activated comprising voice-recognition technologies. A visual and/or audible signal, such as a flashing light and/or beeping tone, may be incorporated to alert a surgeon to the completion or resumption of suction. Suction controller may be slaved to a robotic system which may include, for example, head-mounted displays which integrate 3-D visualization of surgical anatomy and related diagnostic and monitoring data, miniature high resolution 2-D and 3-D digital cameras, a computer, a high power light source and a standard video monitor.

In this embodiment, suction paddles **22**, suction ports **33**, suction apertures and suction conduits are all generally similar to those previously described. As shown in this embodiment, the suction device is constructed such that each suction paddle **22** is coupled to a separate suction line allowing them to be independently disconnected from their respective suction source.

Another embodiment of suction paddles **22**, is shown in **FIG. 56**. Suction paddle **22** is shown in this embodiment to comprise a series of four suction ports **33** each of which is connected in fluid communication to suction conduit **31** through suction aperture **32**. In this embodiment, suction paddle **22**, suction ports **33**, suction apertures **32** and suction conduits **31** are all generally similar to those previously described. **FIG. 57** is a side view of suction paddle **22** showing the low profile design of suction paddle **22** in this embodiment. A low profile suction paddle helps provide more room for performing a surgical procedure, such as sewing an anastomosis in the area of the suction paddles.

The term "tissue engager array" used herein comprises a first tissue engaging member, a second tissue engaging member and a spreader. A tissue engager array may be used with other components to form a tissue immobilizing device. As discussed earlier, the tissue immobilizing devices described herein may include additional features, for example, the ability to provide for the distribution of irrigation fluid onto the area of the heart where the surgical procedure will be performed. The suction device may feature the ability to provide light to where the surgical procedure will be performed, for example, via an optical fiber coupled to a remote light source. The suction device may feature a suture securing or retaining means, such as a suture coil or a plurality of slots formed in the upper

surfaces of suction paddles. The suction device may feature one or more electrodes, a cutting apparatus or a visual means.

As disclosed, the present invention relates to a method and apparatus for immobilizing tissue. In the preferred embodiment, the invention is used to immobilize heart tissue for a coronary artery bypass graft procedure using either an open or closed chest approach, without the need for a cardiopulmonary bypass. Other surgical techniques, however, which require immobilizing body tissue may also be performed using the present invention, such as surgery on other organs such as the stomach, gall bladder, etc., as well as on other body tissues, such as the eye or the skin, for example. In addition, while the present invention has been described in detail with particular reference to a preferred embodiment and alternate embodiments, it should be understood variations and modifications can be effected within the scope of the following claims. Such modifications may include substituting elements or components which perform substantially the same function in substantially the same way to achieve substantially the same result for those described herein.

WHAT IS CLAIMED IS

What is claimed is:

1. A tissue immobilizing device for stabilizing tissue within a patient's body cavity, comprising:
 - an arm having a distal end and a proximal end;
 - an actuator carried on the arm proximal end;
 - a spreader carried on the arm distal end, the spreader coupled to the actuator;
 - a first tissue engaging member carried on the arm distal end and coupled to the spreader, the first tissue engaging member having a first position, a second position, and at least a third position; and,
 - a second tissue engaging member carried on the arm distal end coupled to the spreader, the second tissue engaging member having a first position, a second position, and at least a third position;wherein the actuator is configured to operate the spreader to selectively control the movement of the first tissue engaging member among the first position, the second position, and the third position and selectively control the movement of the second tissue engaging member among the first position, the second position, and the third position.
2. The tissue immobilization device as in claim 1 wherein the selective amount of spreading permits a first tissue engaging member and a second tissue engaging member to be spread proximate to the tissue area desired to be stabilized.
3. The tissue immobilization device as in claim 1 wherein the first tissue engaging member and the second tissue engaging member move substantially parallel to one another when the first tissue engaging member moves from the second position to the third position and the second tissue engaging member moves from the second position to the third position.
4. The tissue immobilization device as in claim 1 wherein the actuator is a mechanical control

5. The tissue immobilization device as in claim 4 wherein the mechanical control is a hand lever control.
6. The tissue immobilization device as in claim 4 wherein the mechanical control is a control knob.
7. The tissue immobilization device as in claim 4 wherein the mechanical control is a control slide.
8. The tissue immobilization device as in claim 1, wherein the actuator is controlled by a clinician.
9. The tissue immobilization device as in claim 8 wherein the actuator is a device selected from the group consisting of an automated system, a robot, an electro-mechanical device, and a mechanical device.
10. The tissue immobilization device as in claim 1 wherein the first tissue engaging member and the second tissue engaging member are spaced apart a first distance when the first tissue engaging member is in the first position and the second tissue engaging member is in the first position.
11. The tissue immobilization device as in claim 10 wherein the first distance is less than about 15 mm causing the first tissue engaging member and the second tissue engaging member to be substantially together.
12. The tissue immobilization device as in claim 10 wherein the first tissue engaging member and the second tissue engaging member are spaced apart a second distance that is greater than the first distance when the first tissue engaging member is in the second position and the second tissue engaging member is in the second position.
13. The tissue immobilization device as in claim 12 wherein when the first tissue engaging member and the second tissue engaging member are spaced apart a third distance that is greater than a second distance when the first tissue engaging member is in the third position and the second tissue engaging member is in the third position.
14. The tissue immobilization device as in claim 1 wherein the arm is configured to fasten to a stationary object to substantially fix the first tissue engaging

- member and the second tissue engaging member in relation to the stationary object.
15. The tissue immobilization device as in claim 14 wherein the stationary object is a trocar sleeve.
 16. The tissue immobilization device as in claim 14 wherein the stationary object is selected from the group consisting of an operating table and a retractor.
 17. The tissue immobilization device as in claim 1 wherein the first tissue engaging member and the second tissue engaging member have a coupling surface selected from the group consisting of at least one suction cup, an adhesive surface, and a friction surface.
 18. The tissue immobilization device as in claim 17 wherein the at least one suction cup is coupled to a suction source.
 19. The tissue immobilization device as in claim 1, further comprising an arm variable joint positioned between the arm distal end and arm proximal end for articulating the arm to position the arm distal end.
 20. The tissue immobilization device as in claim 19, further comprising a variable joint positioner.
 21. The tissue immobilization device as in claim 20 wherein the arm variable positioner is selected from the group consisting of an automated system, robotic system, an electro-mechanical control, and a mechanical control.
 22. A tissue immobilizing device for stabilizing tissue within a patient's body cavity, comprising:
 - an arm having a distal end and a proximal end;
 - an actuator carried on the arm proximal end;
 - a spreader carried on the arm distal end, the spreader coupled to the actuator;
 - a first tissue engaging member carried on the arm distal end and coupled to the spreader, the first tissue engaging member having a first position and at least a second position; and,
 - a second tissue engaging member carried on the arm distal end coupled to the spreader, the second tissue engaging member having a first position and at least a second position;

means for selectively controlling operated by the actuator, the means for selectively controlling the movement of the first tissue engaging member from the first position to the second position and selectively control the movement of the second tissue engaging member from the first position to the second position.

23. A tissue engager array for a tissue immobilizing device, comprising:
a first tissue engaging member, the first tissue engaging member having a first position, a second position, and at least a third position; and,
a second tissue engaging member operable positioned to the first tissue engaging member, the second tissue engaging member having a first position, a second position, and at least a third position;
a spreader coupled to the first tissue engaging member and coupled to the second tissue engaging member, the spreader configured to move the first tissue engaging member among the first position, the second position, and the third position, and the second tissue engaging member among the first position, the second position, and the third position so a selective amount of spreading occurs.
24. The tissue immobilization device as in claim 23 wherein the selective amount of spreading permits a first tissue engaging member and a second tissue engaging member to be spread proximate to the tissue area desired to be stabilized.
25. The tissue immobilization device as in claim 23, wherein the selective spreading is accomplished with an actuator positioned on the arm, the actuator being coupled to the spreader and controllable by a clinician.
26. The tissue immobilization device as in claim 25 wherein the actuator is a mechanical control.
27. The tissue immobilization device as in claim 26 wherein the mechanical control is a hand lever control.
28. The tissue immobilization device as in claim 26 wherein the mechanical control is a control knob.

29. The tissue immobilization device as in claim 26 wherein the mechanical control is a control slide.
30. The tissue immobilization device as in claim 26 wherein the actuator is controlled by a clinician using a device selected from the group consisting of an automated system, a robot, an electro-mechanical device, and a mechanical device.
31. A tissue engager array for a tissue immobilizing device, comprising:
a first tissue engaging member, the first tissue engaging member having a first position, a second position, and at least a third position;
a second tissue engaging member operable positioned to the first tissue engaging member, the second tissue engaging member having a first position, a second position, and at least a third position; and,
means for spreading coupled to the first tissue engaging member and coupled to the second tissue engaging member, the means for spreading configured to move the first tissue engaging member among the first position, the second position, and the third position, and the second tissue engaging member among the first position, the second position, and the third position so a selective amount of spreading occurs.
32. A method for immobilizing a tissue area within a patient's body, comprising:
introducing a first tissue engaging member carried on an arm distal end and a second tissue engaging member carried on the arm distal end into a patient's body with the first tissue engaging member and second tissue engaging member configured substantially together;
spreading the first tissue engaging member away from the second tissue engaging member after the first tissue engaging member and second tissue engaging member are within the patient's body;
controlling the spreading of the first tissue engaging member away from the second tissue engaging member, so a selective amount of spreading occurs;
coupling the first tissue engaging member to a first tissue surface and the second tissue engaging member to a second tissue surface to stabilize a tissue area within the patient's body; and,

fastening the arm to a stationary object to substantially fix the first tissue engaging member and the second tissue engaging member in relation to the stationary object.

33. The method as in claim 32 wherein the selective amount of spreading permits a first tissue engaging member and a second tissue engaging member to be spread proximate to the tissue area desired to be stabilized.
34. The method as in claim 32, controlling the spreading is accomplished with an actuator controlled by a clinician positioned on an arm proximal end coupled to a spreader on the arm distal end, the spreader being coupled to the first tissue engaging member and coupled to the second tissue engaging member.
35. The method as in claim 34 wherein the actuator is a mechanical control.
36. The method as in claim 35 wherein the mechanical control is a hand lever control.
37. The method as in claim 35 wherein the mechanical control is a control knob.
38. The method as in claim 35 wherein the mechanical control is a control slide.
39. The method as in claim 34 wherein the actuator is controlled by a clinician using a device selected from the group consisting of an automated system, a robot, an electro-mechanical device, and a mechanical device.
40. The method as in claim 32 wherein the stationary object is a trocar sleeve.
41. The method as in claim 32 wherein the stationary object is selected from the group consisting of an operating table, and a retractor.
42. The method as in claim 32 wherein introducing is accomplished through an entry point.
43. The method as in claim 42 wherein the entry point is selected from the group consisting of an incision, a stab wound, a cannula, a trocar sleeve, a port, and an endoscopic access.
44. The method as in claim 42 wherein the entry point located is selected from the group consisting of a chest wall, an intercostal space, and a sternum.
45. The method as in claim 42 wherein the entry point of a chest wall also includes penetration of the pericardium.

46. The method as in claim 32 wherein coupling is accomplished with the first tissue engaging member and the second tissue engaging member having a coupling surface selected from the group consisting of at least one suction cup, an adhesive surface, and a friction surface.
47. The method as in claim 46 wherein the at least one suction cup is coupled to a suction source.
48. A method for placing immobilized tissue within a patient's body under tension, comprising:
introducing a first tissue engaging member carried on an arm distal end and a second tissue engaging member carried on the arm distal end into a patient's body with the first tissue engaging member and second tissue engaging member configured substantially together;
spreading the first tissue engaging member away from the second tissue engaging member a first distance after the first tissue engaging member and second tissue engaging member are within the patient's body;
coupling the first tissue engaging member to a first tissue surface and the second tissue engaging member to a second tissue surface to substantially immobilize a tissue area within the patient's body;
spreading the first tissue engaging member away from the second tissue engaging member while maintaining the first tissue engaging member substantially parallel to the second tissue engaging member a second distance after the first tissue engaging member has been coupled to the first tissue surface and second tissue engaging member has been coupled to the second tissue surface to place the substantially immobilized tissue under tension within a patient's body; and,
fastening the arm to a stationary object to substantially fix the first tissue engaging member and the second tissue engaging member in relation to the stationary object.
49. The method as in claim 48 wherein the substantially immobilized tissue under tension increases tissue stability compared to substantially immobilized tissue that is not under tension.

50. The method as in claim 48 wherein the substantially immobilized tissue under tension increases tissue exposure compared to substantially immobilized tissue that is not under tension.

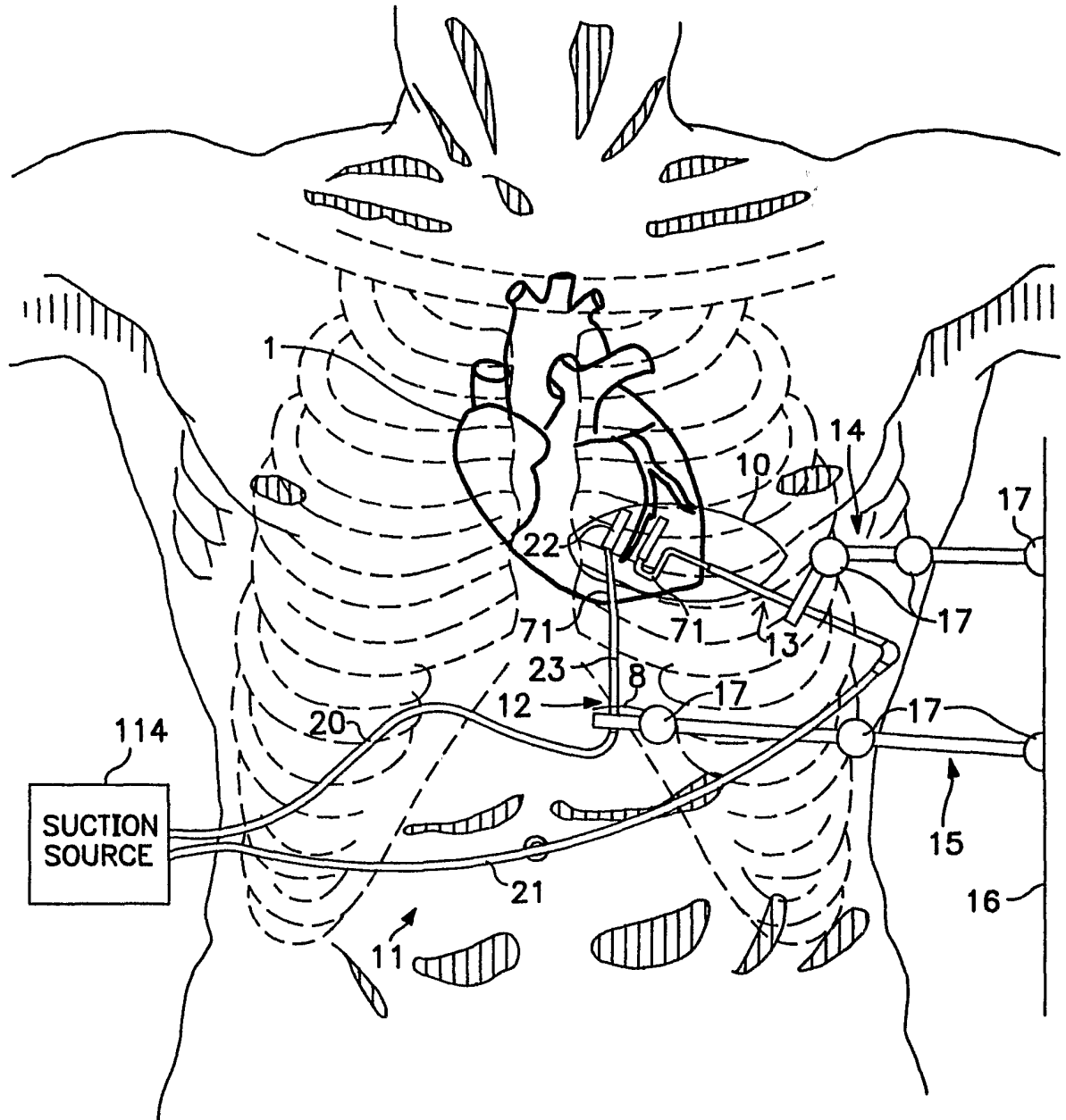

FIG. 1

FIG. 2a

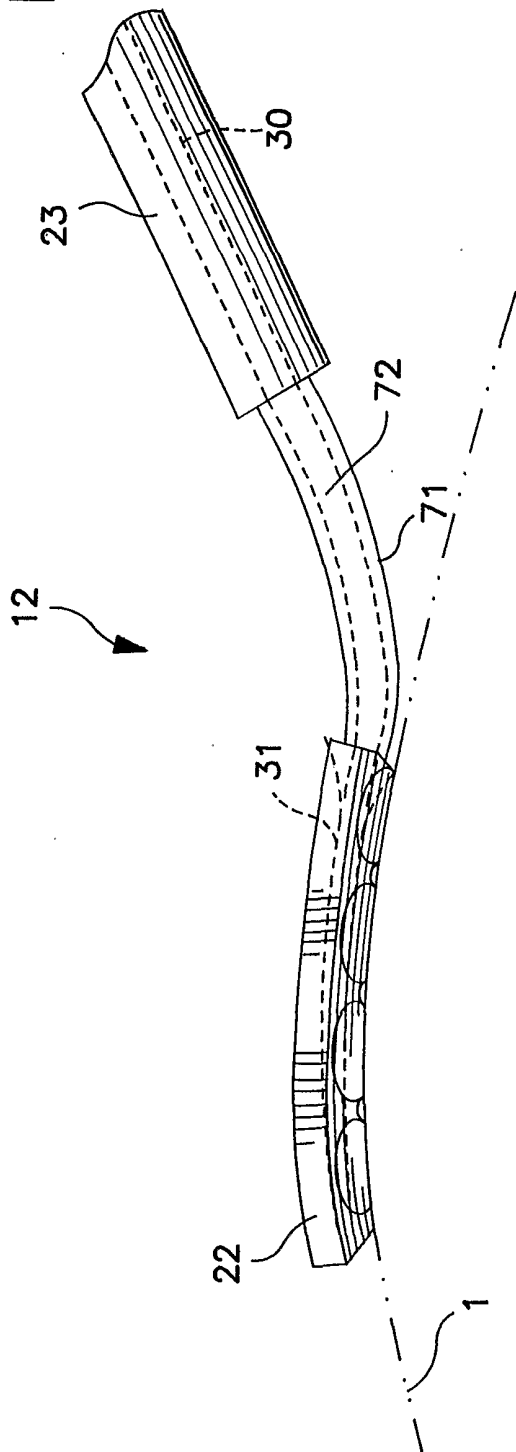
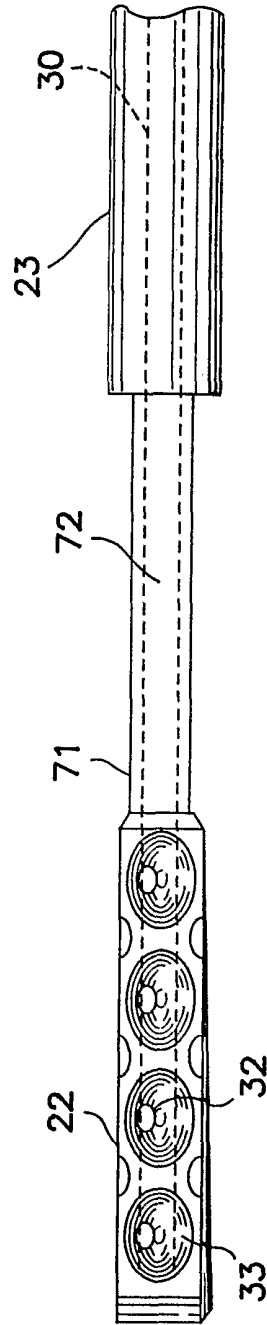

FIG. 2b



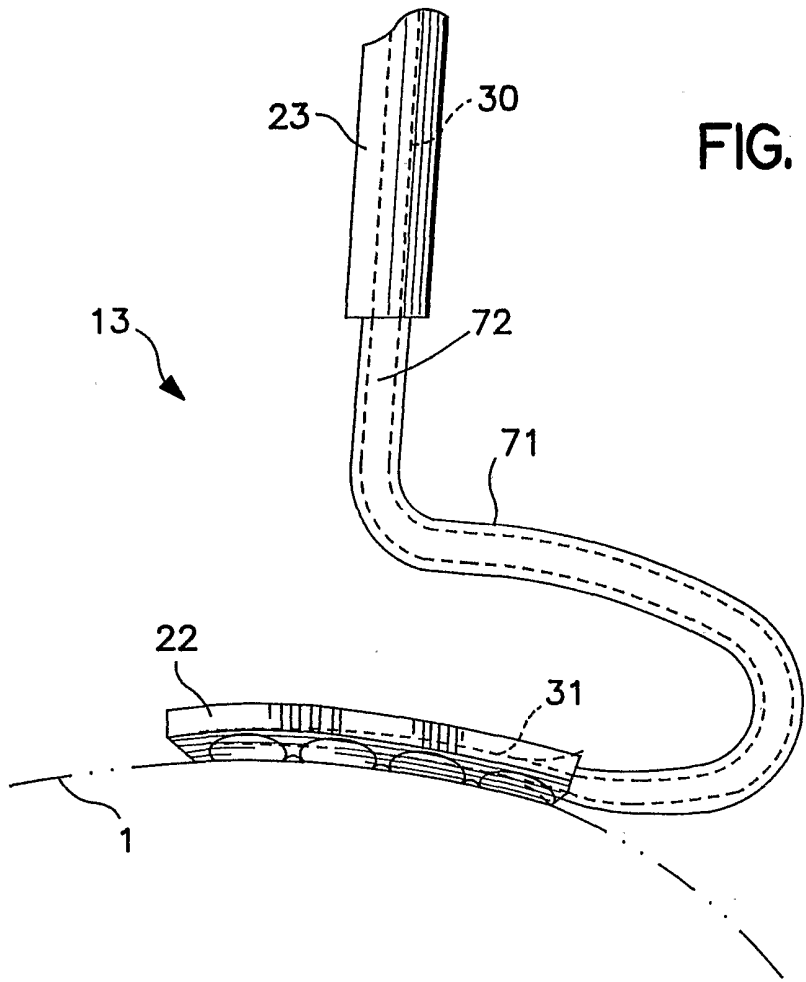

FIG. 3a

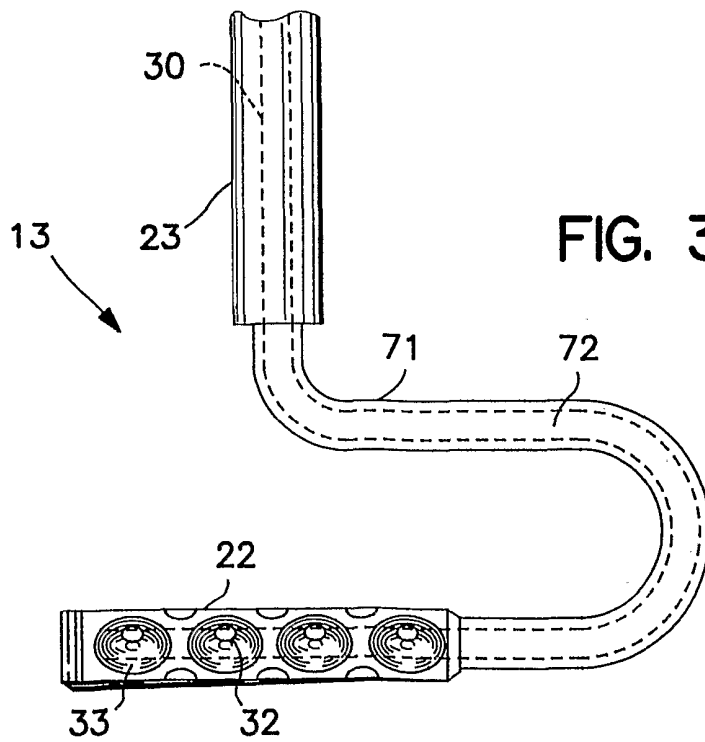

FIG. 3b

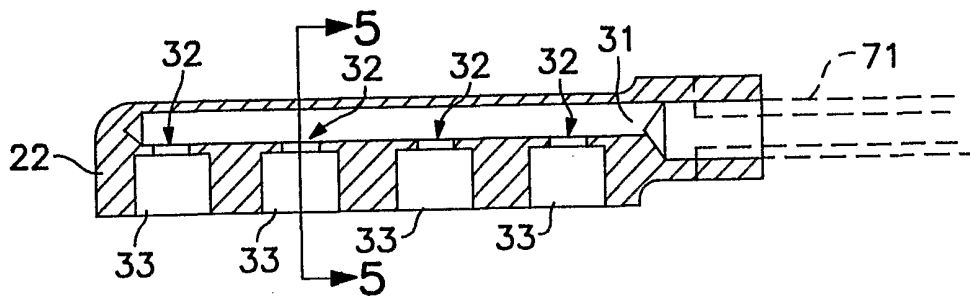

FIG. 4

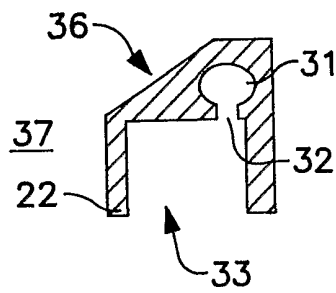

FIG. 5

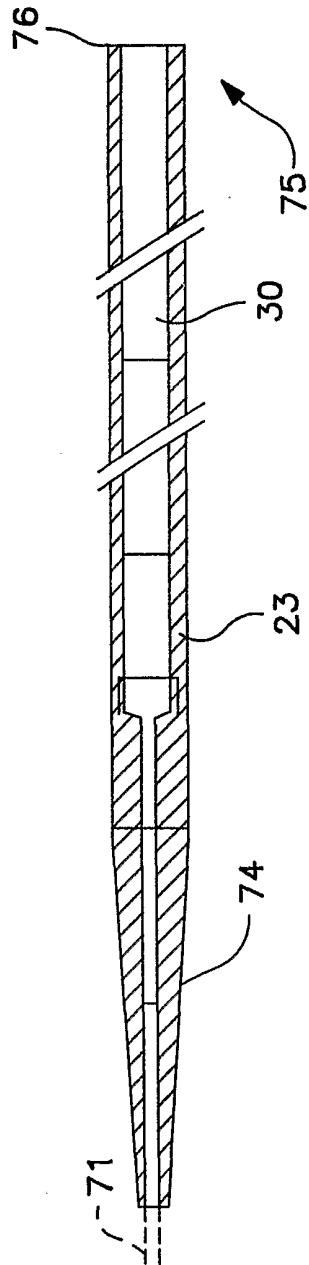

FIG. 6

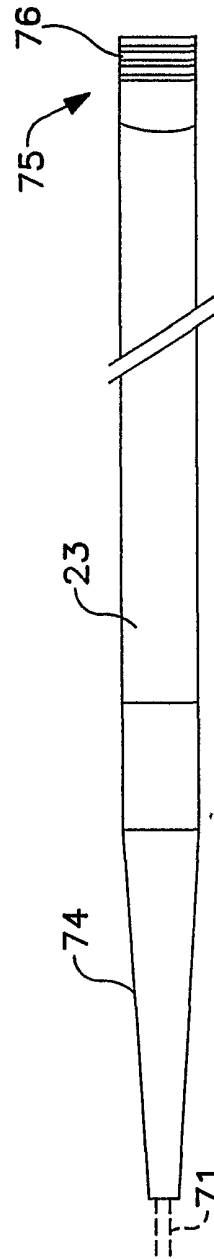

FIG. 7

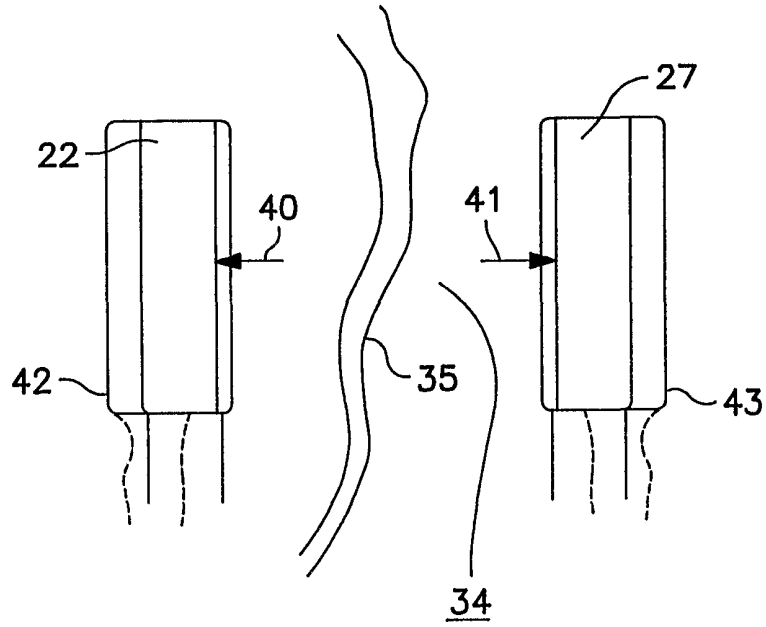

FIG. 8

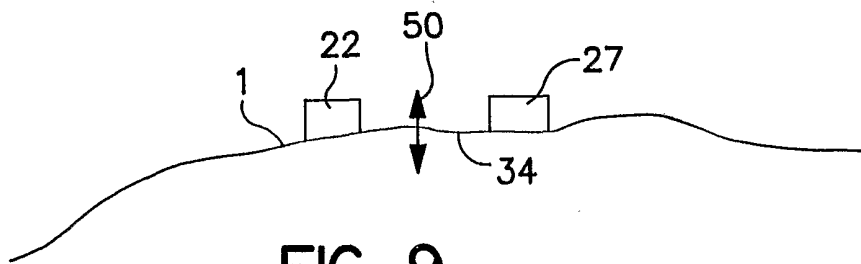

FIG. 9

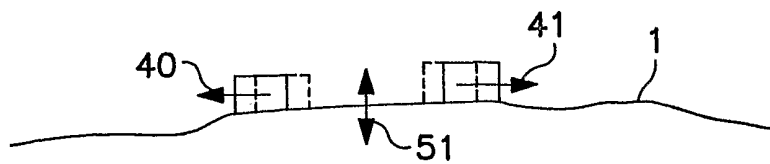

FIG. 10

7/32

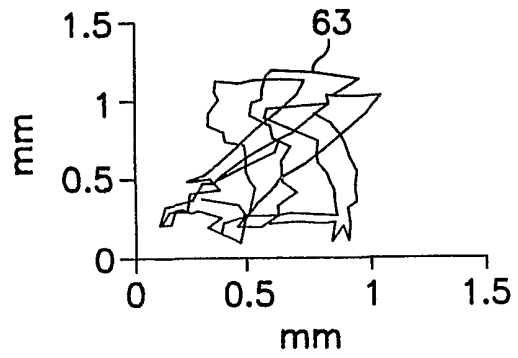

FIG. 12

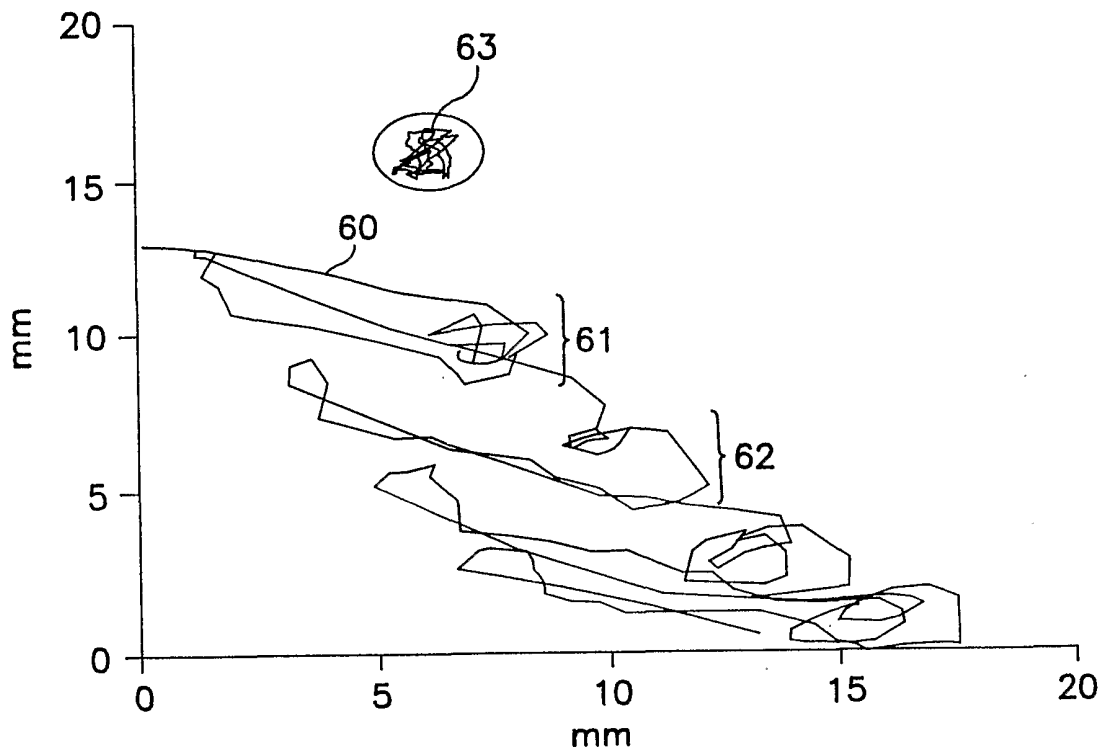

FIG. 11

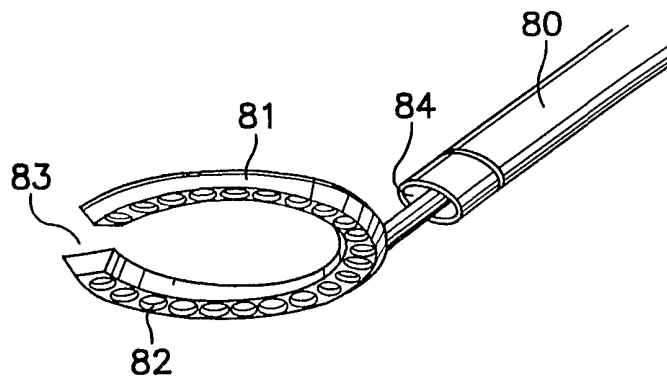

FIG. 13

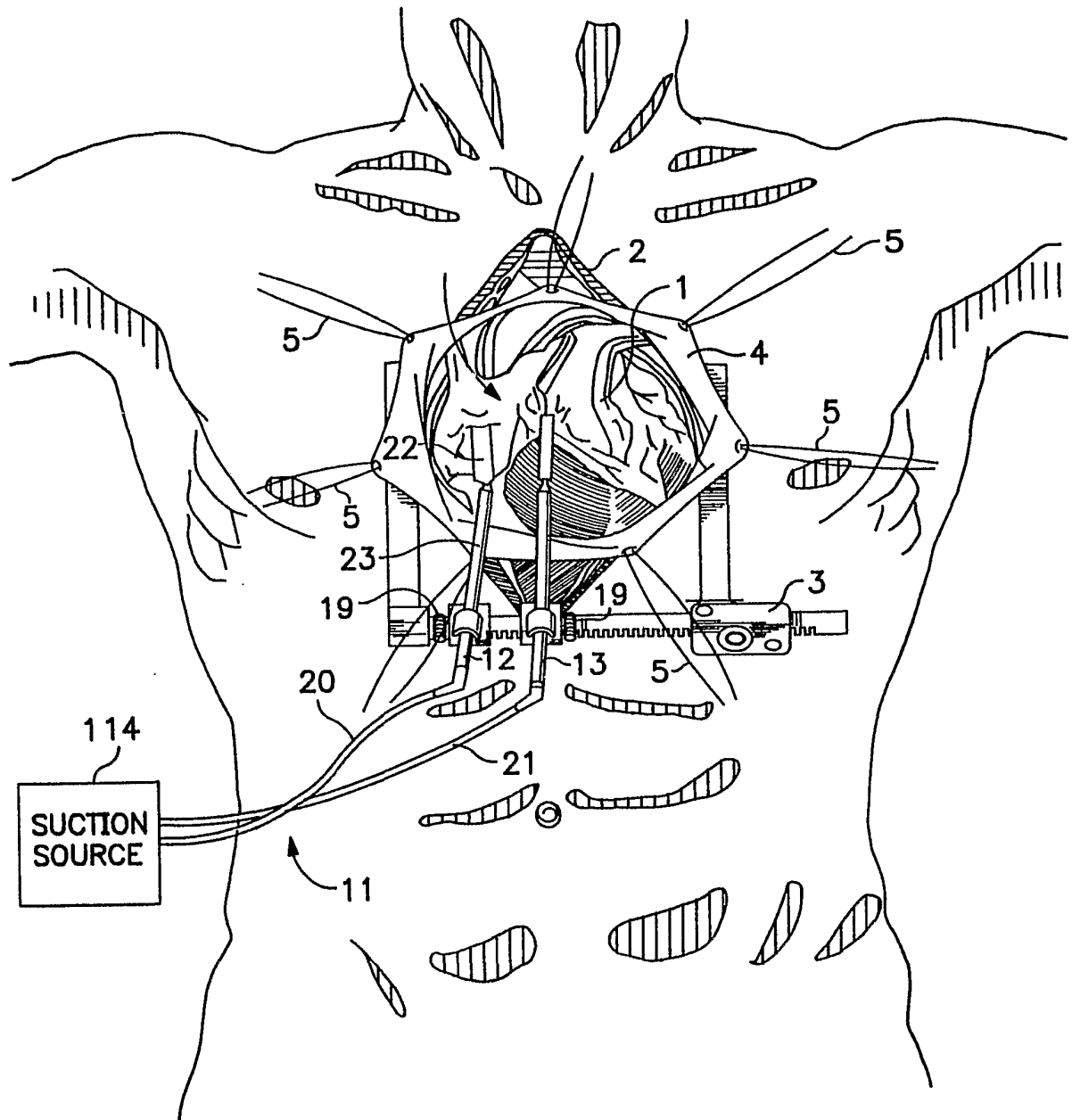
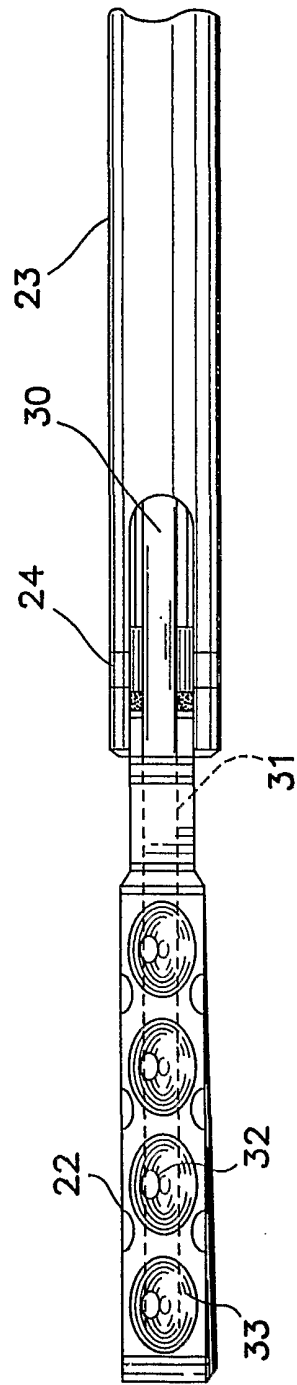
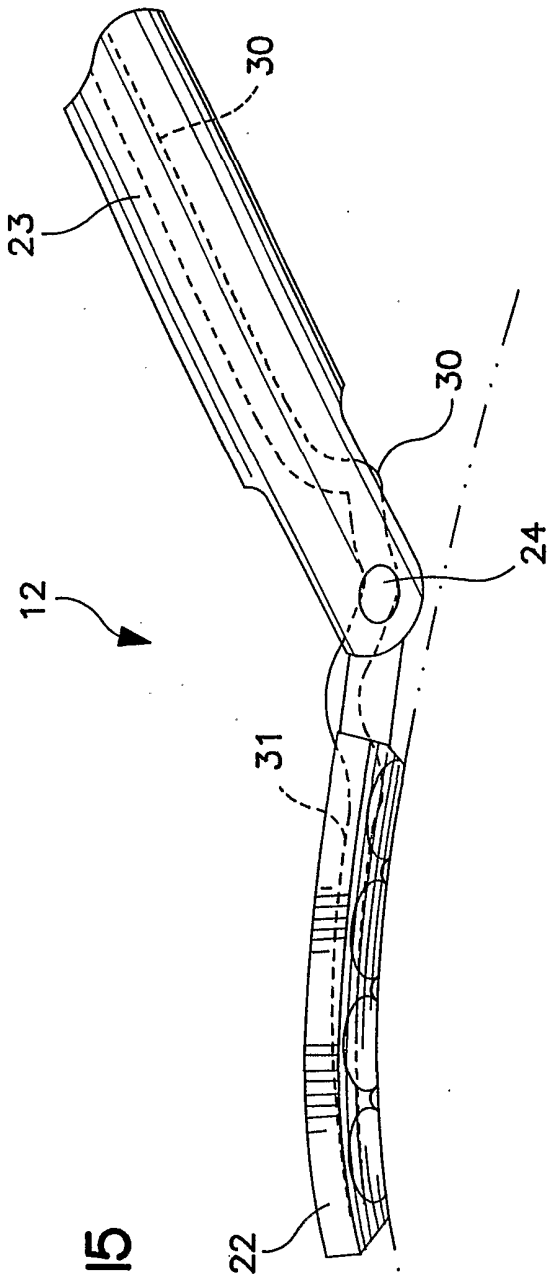

FIG. 14



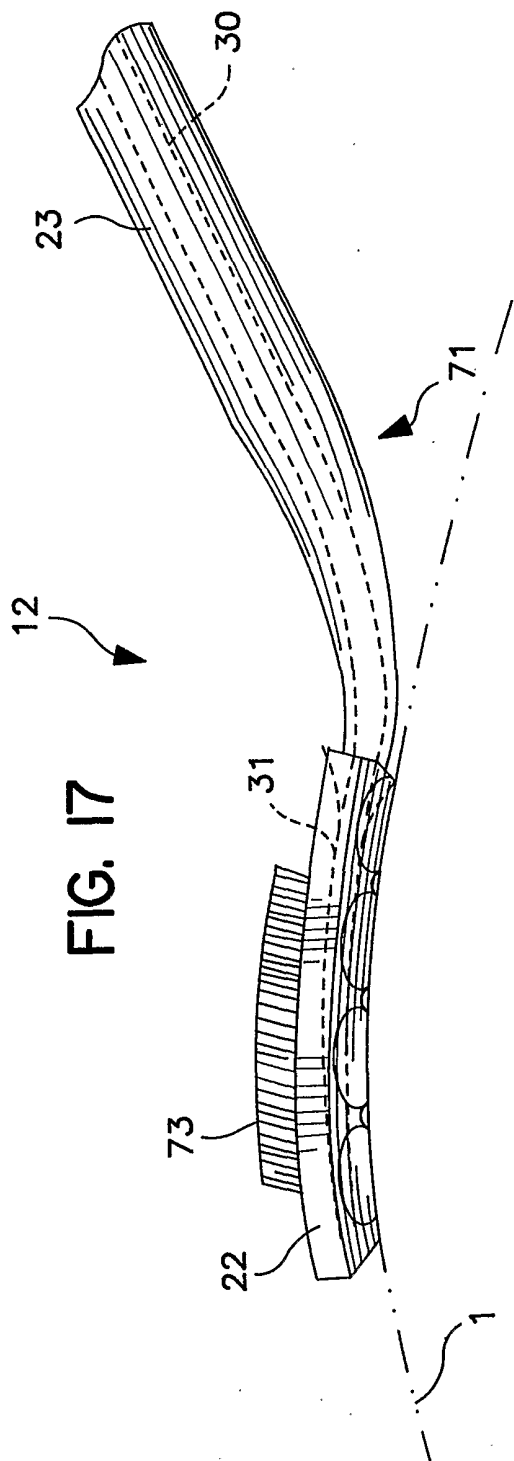

FIG. 17

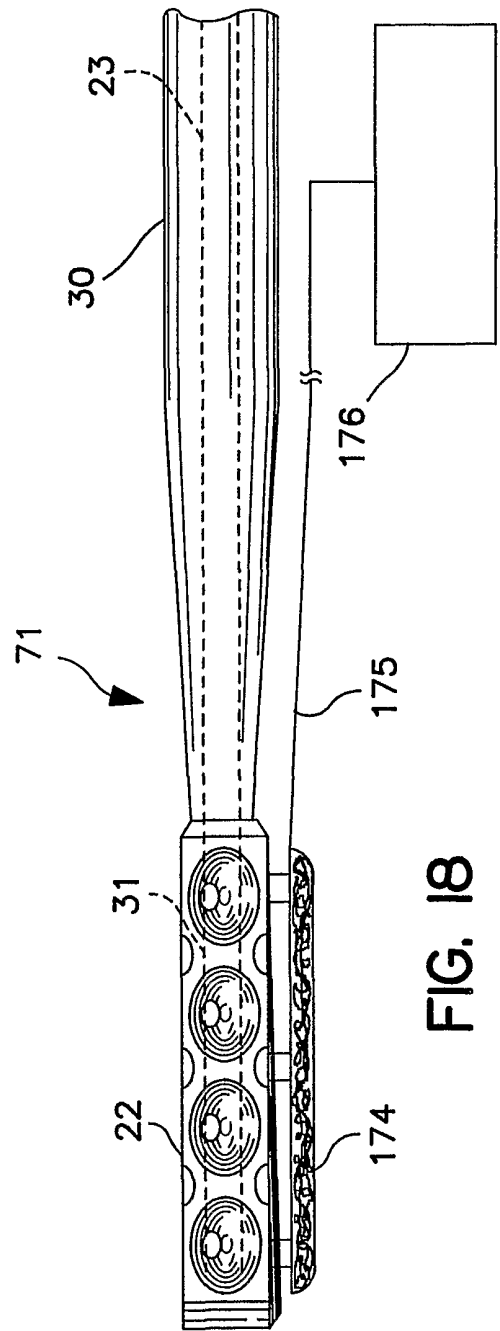

FIG. 18

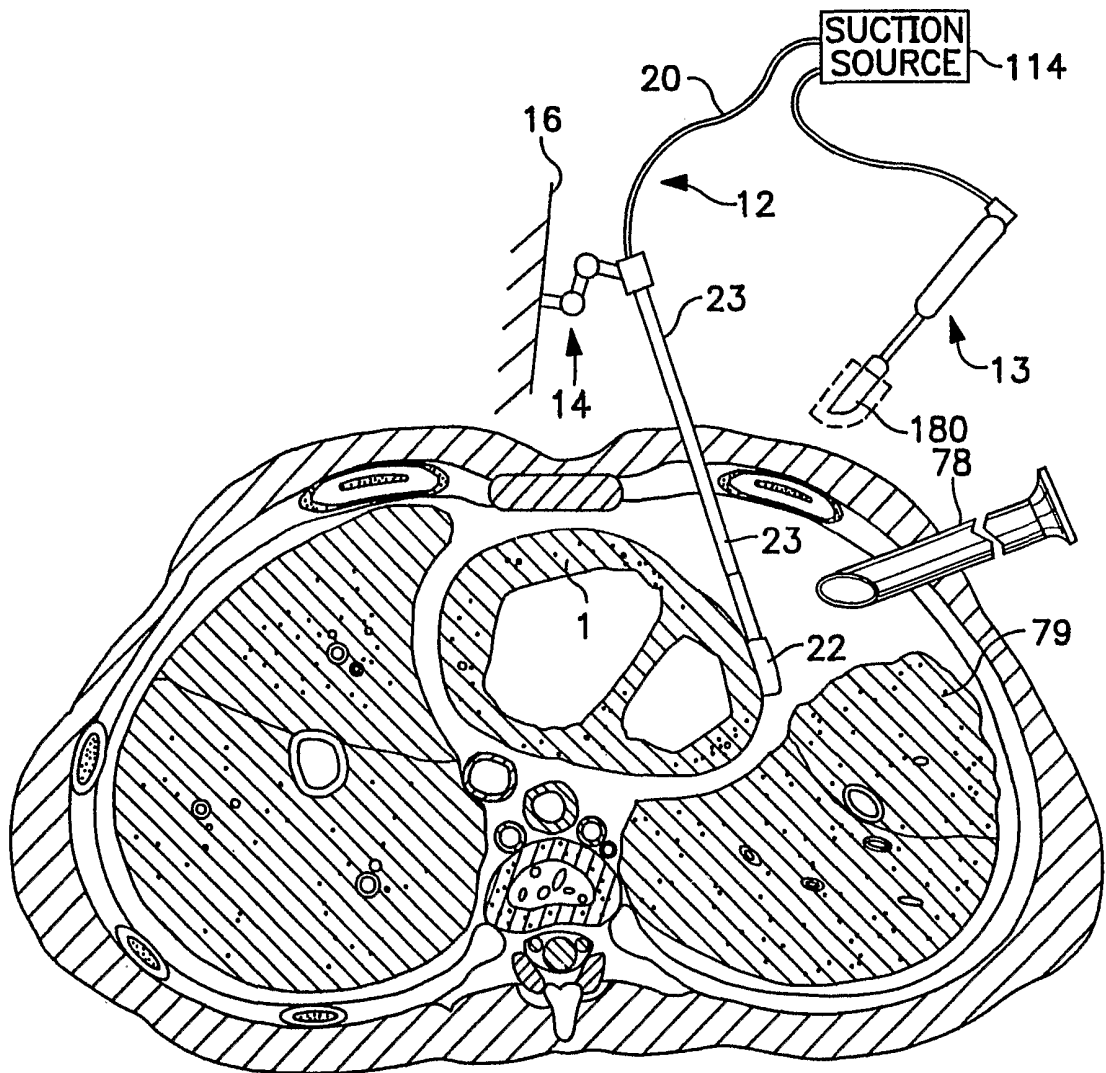

FIG. 19

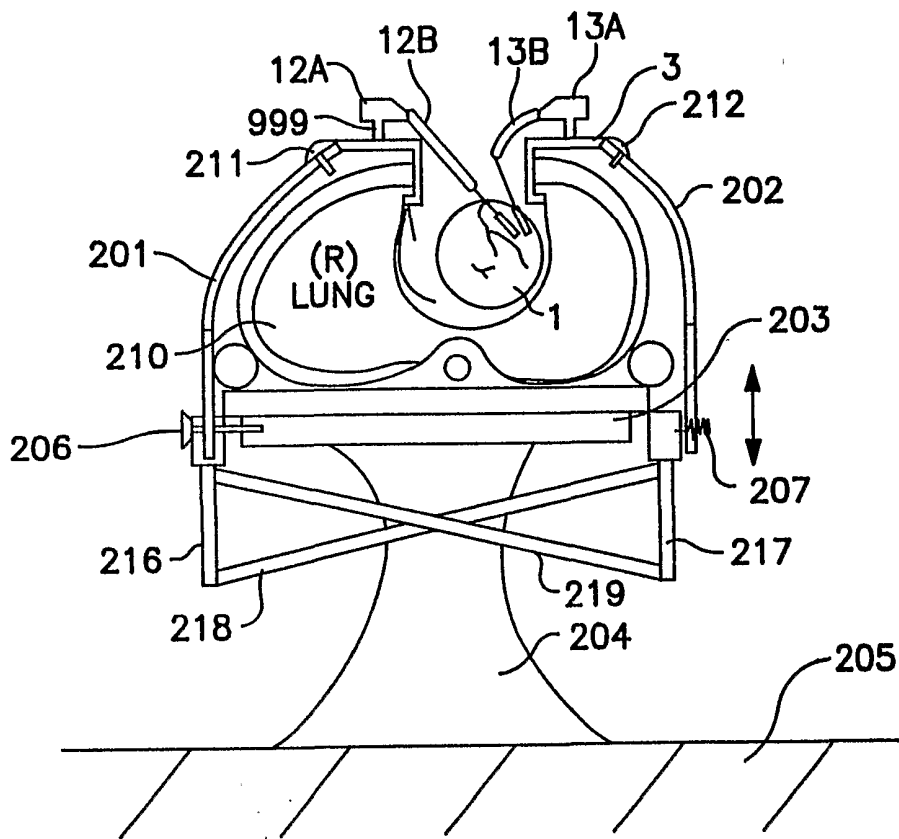

FIG. 20a

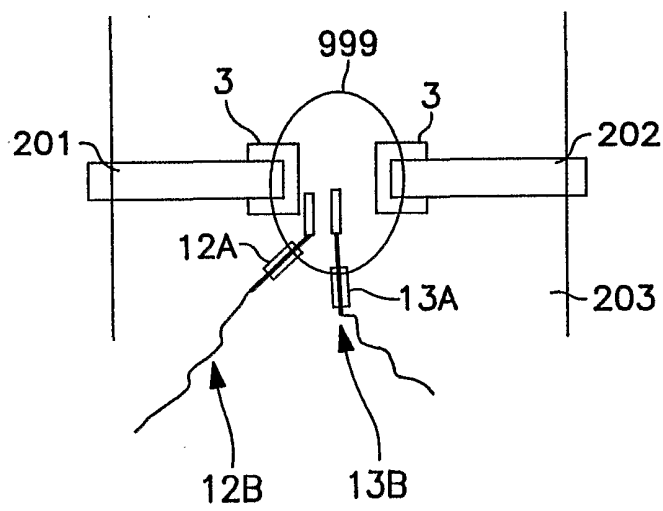

FIG. 20b

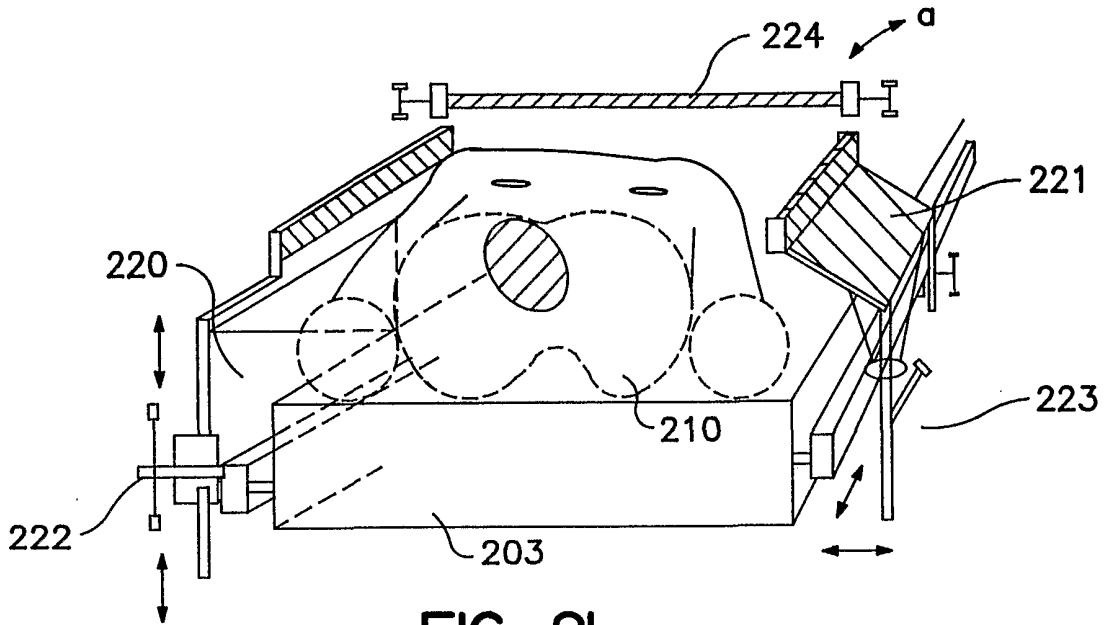

FIG. 21

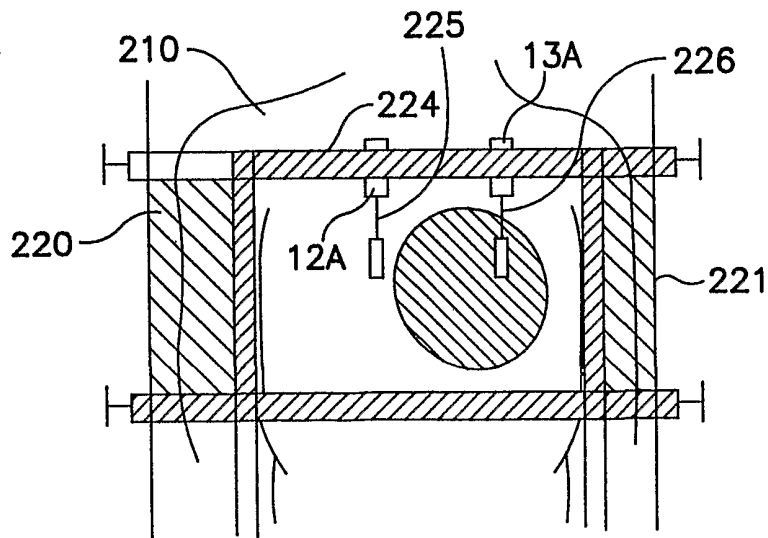

FIG. 22

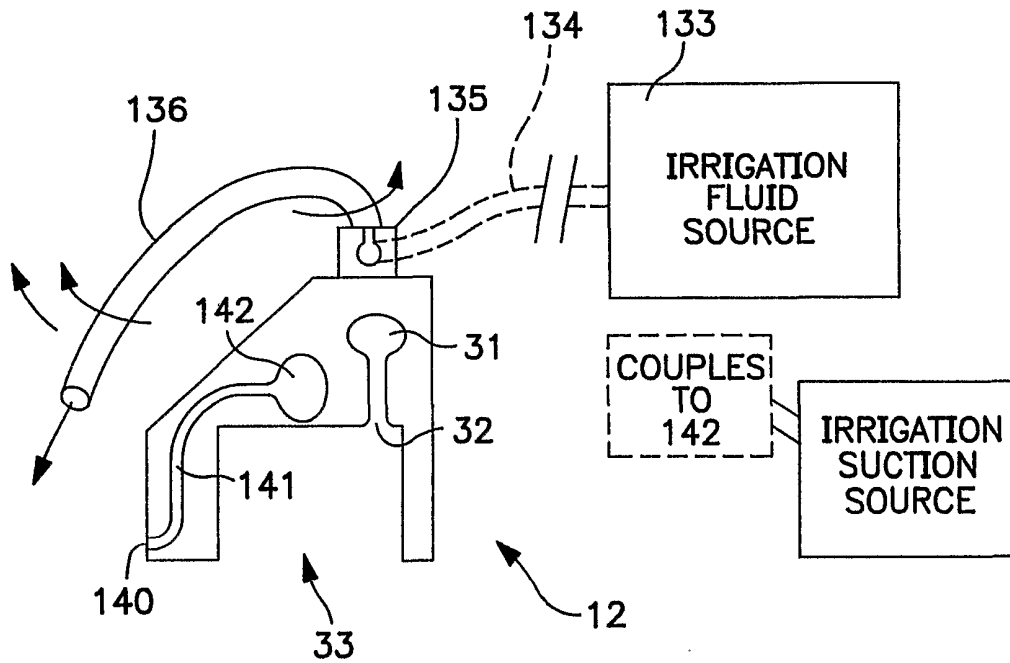

FIG. 23

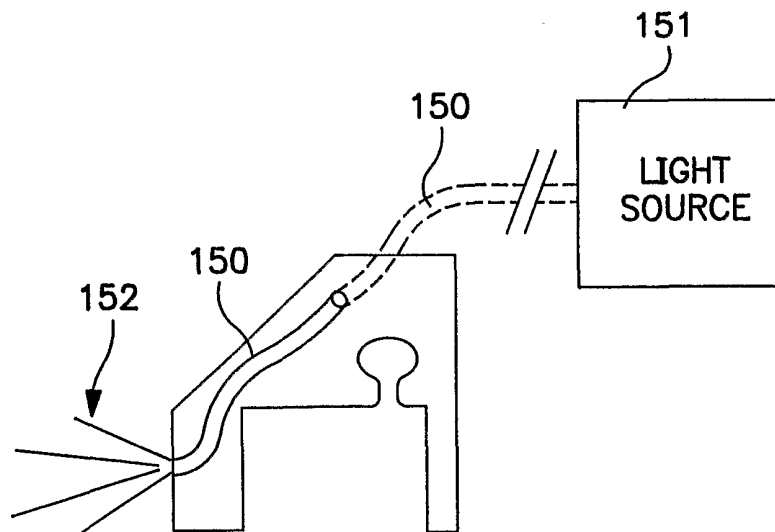

FIG. 24

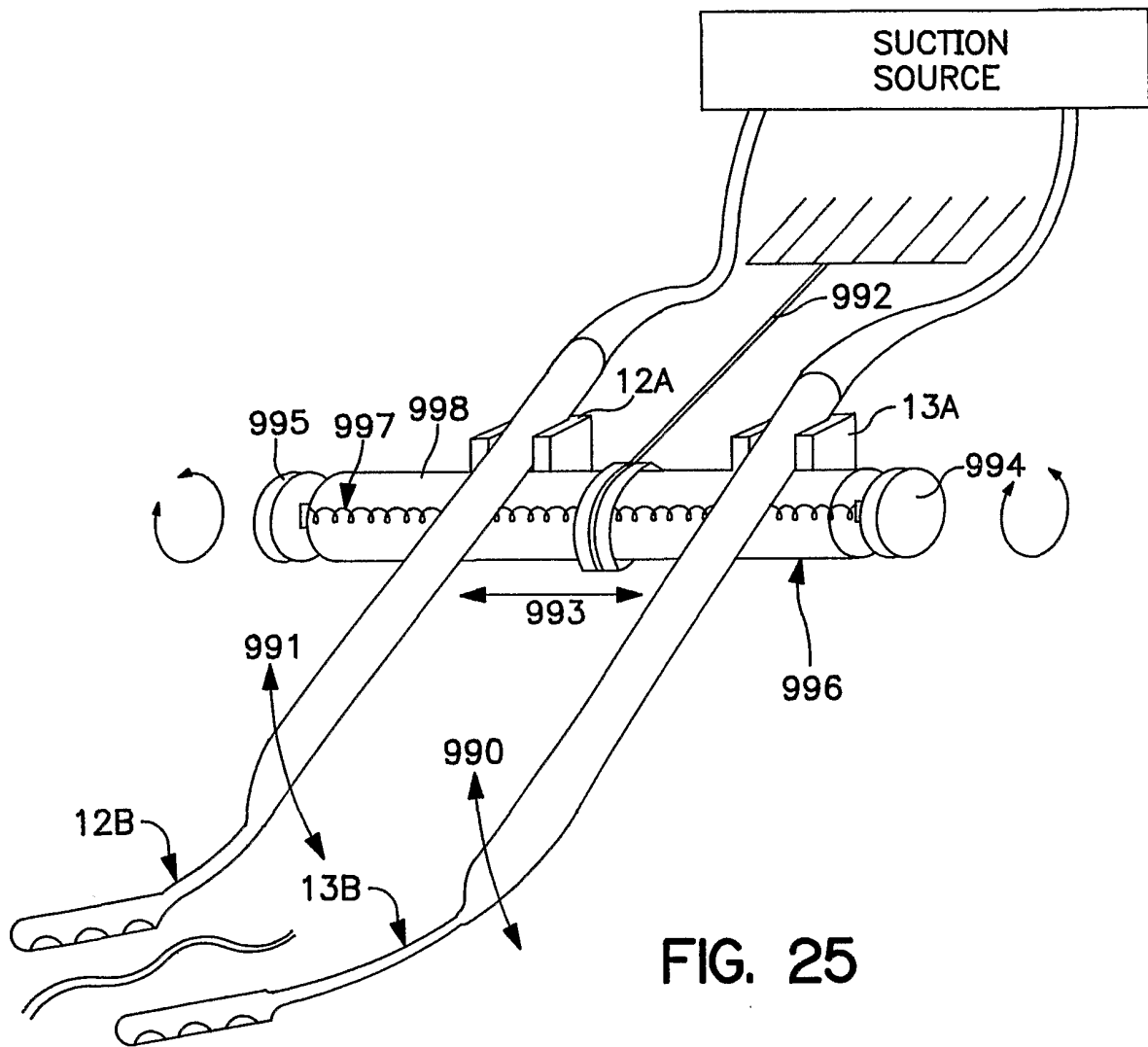

FIG. 25

FIG. 26a

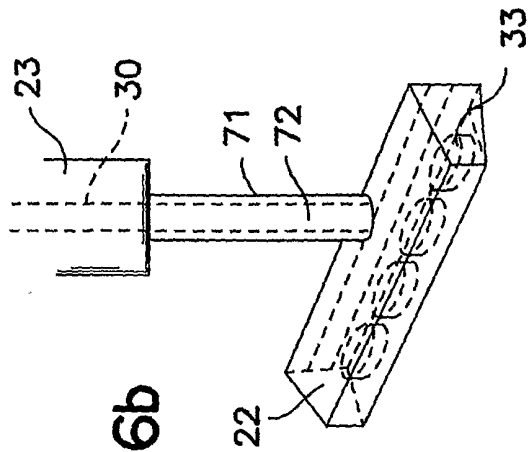
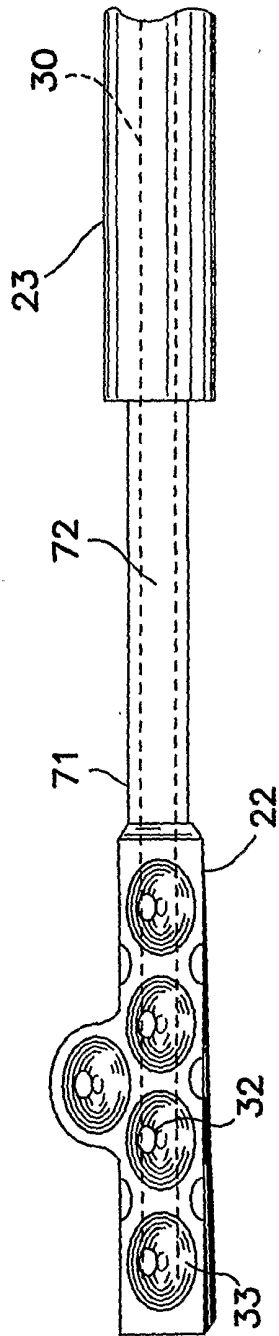

FIG. 26b

18/32

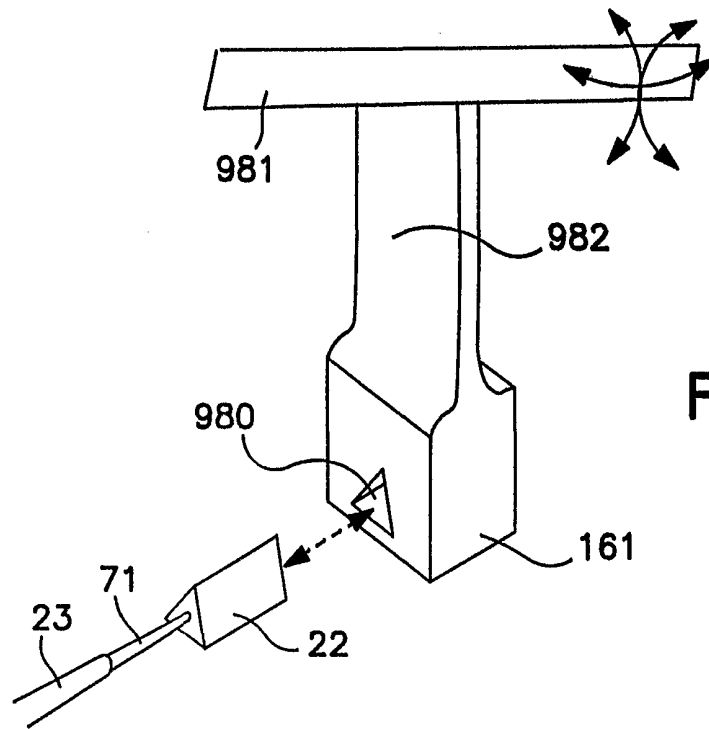

FIG. 27

FIG. 28

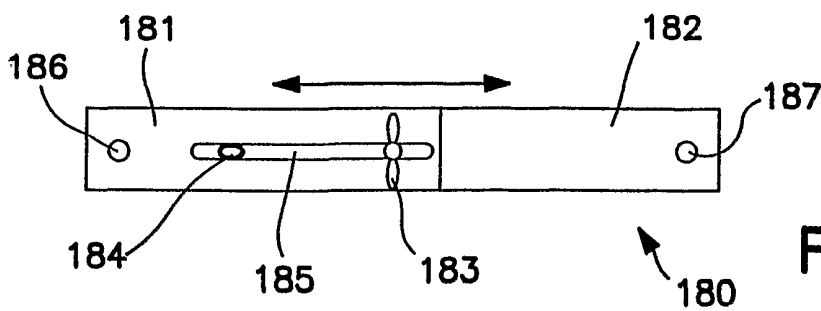
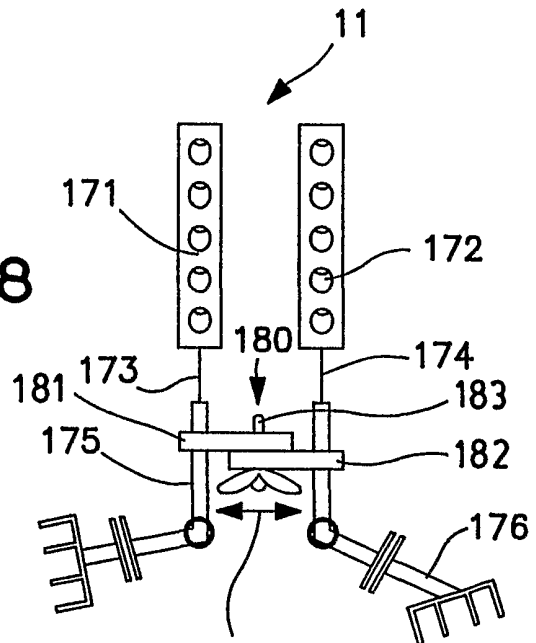

FIG. 29

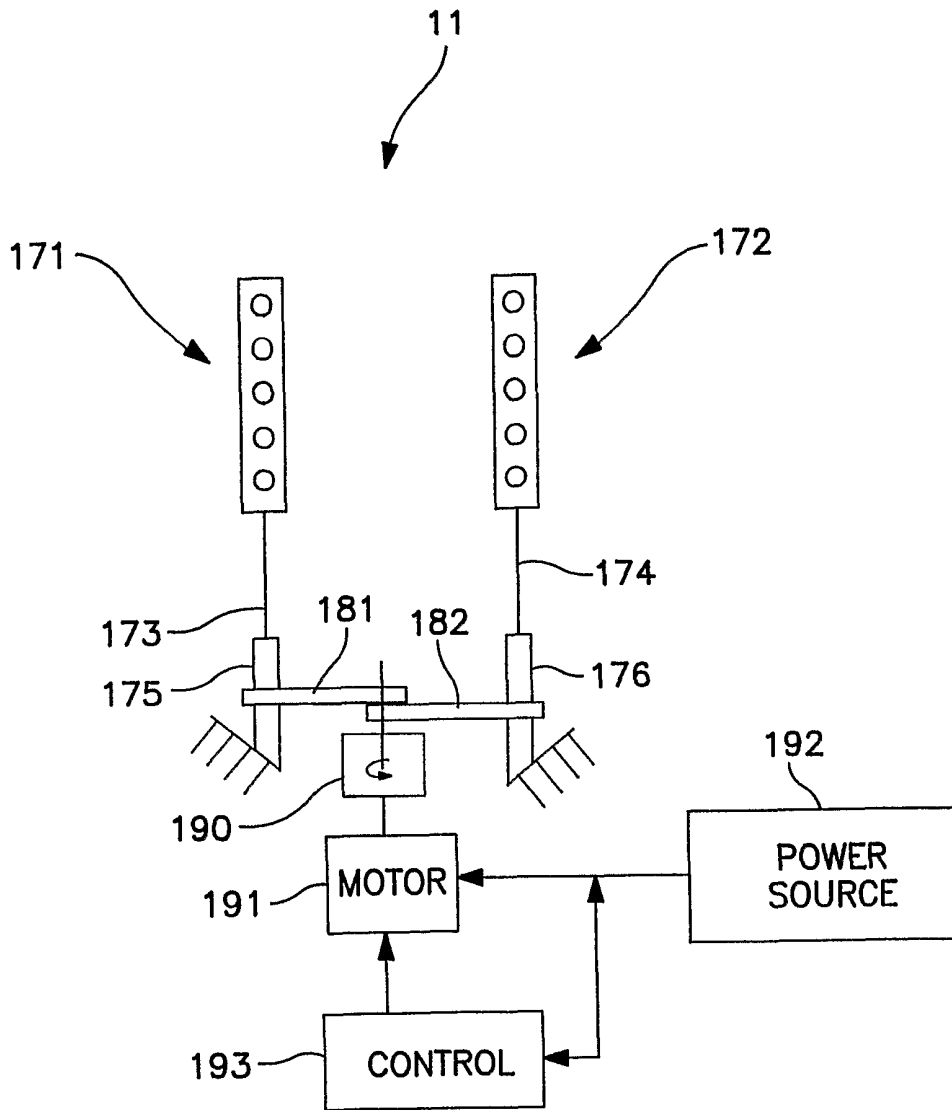

FIG. 30

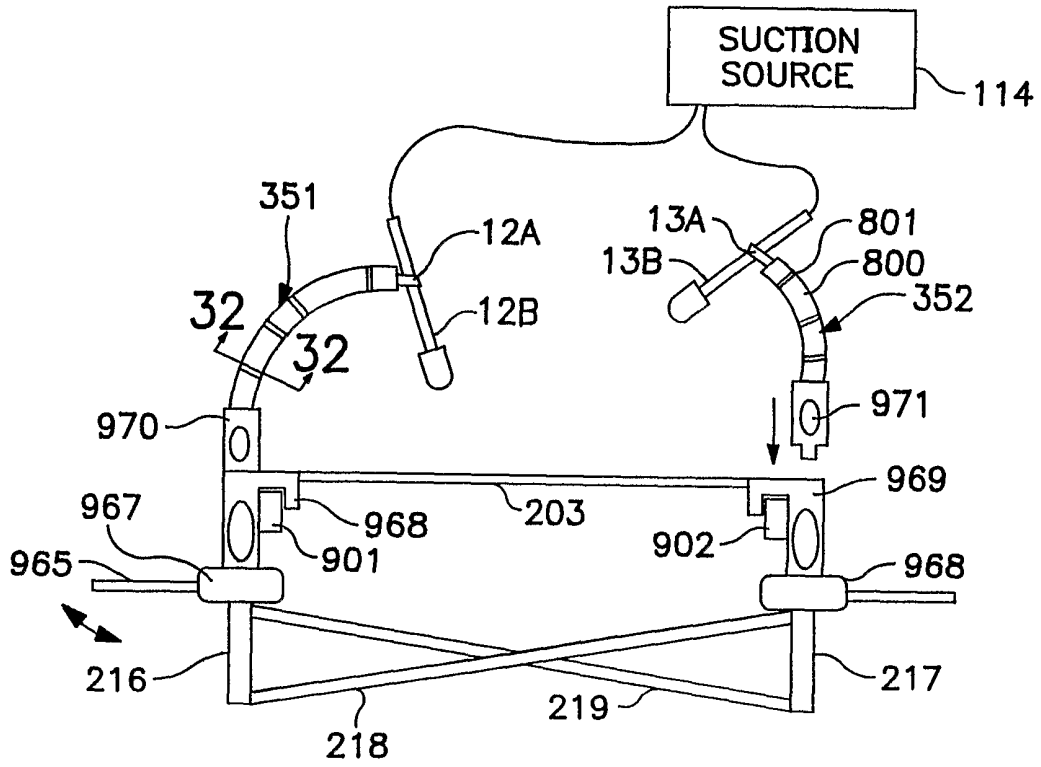

FIG. 31

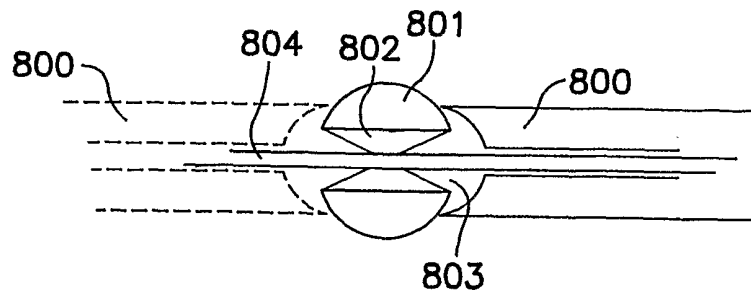

FIG. 32

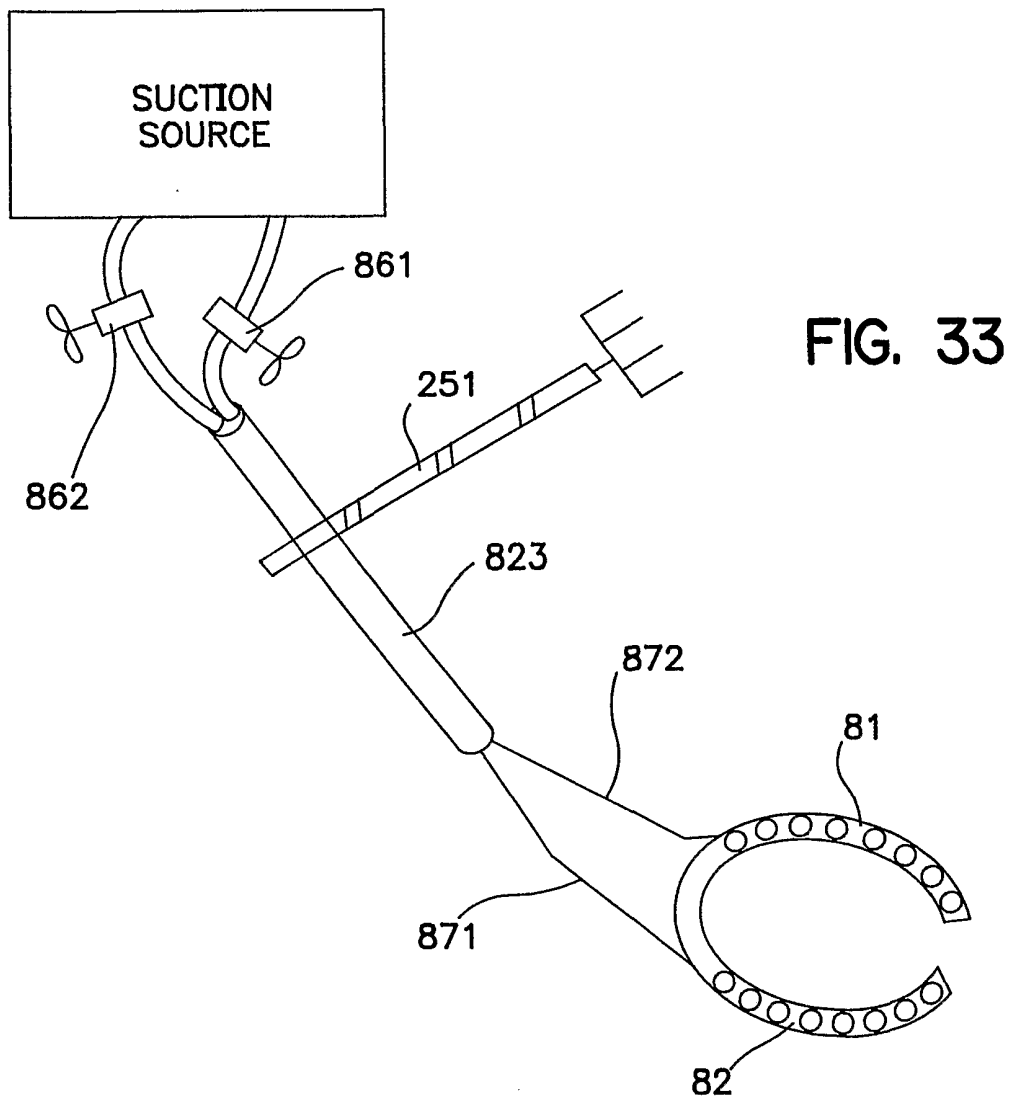

FIG. 33

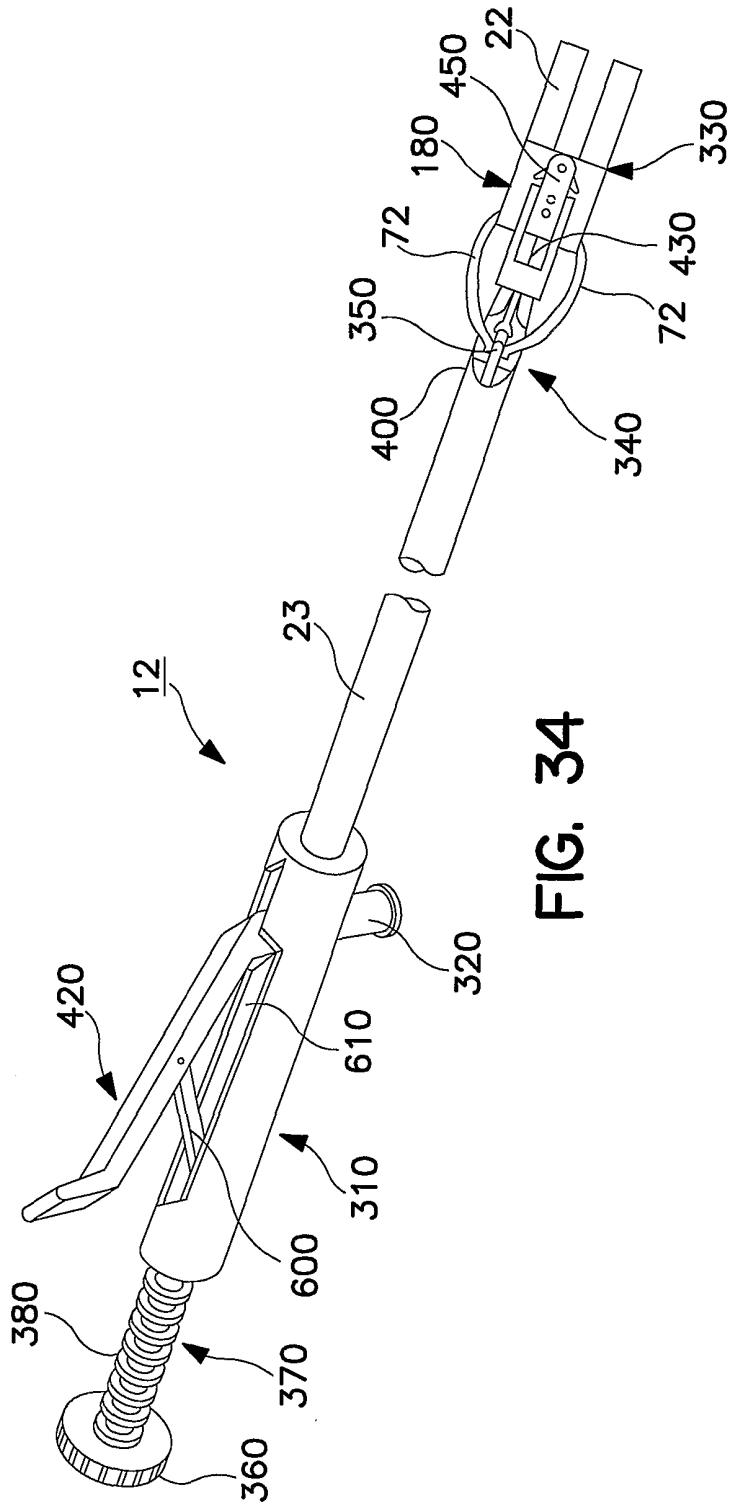

FIG. 34

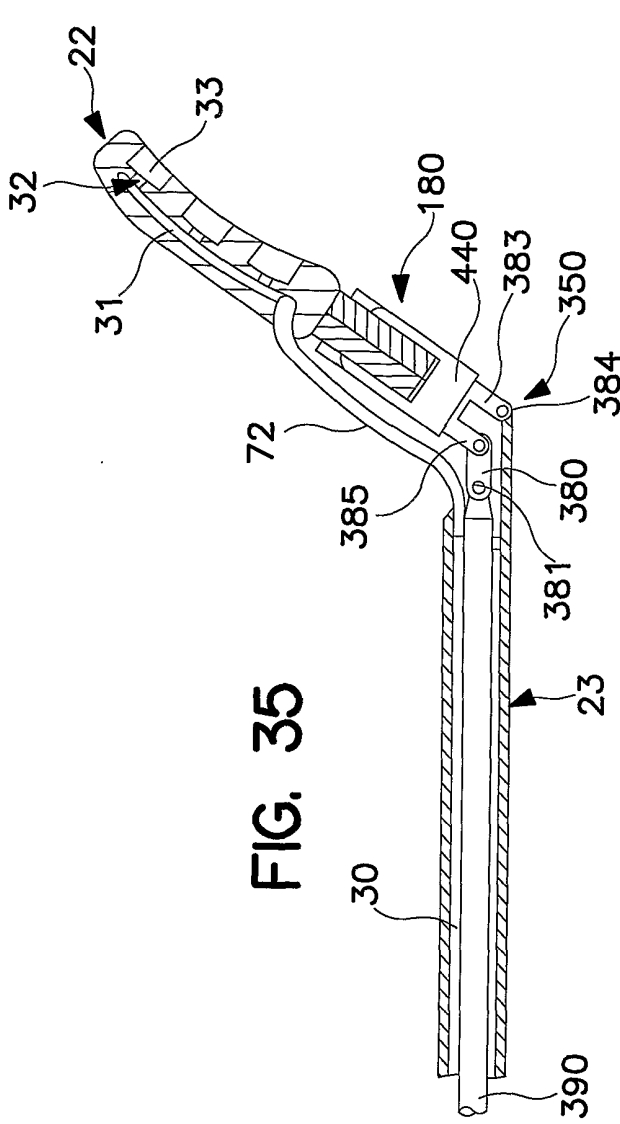

FIG. 35

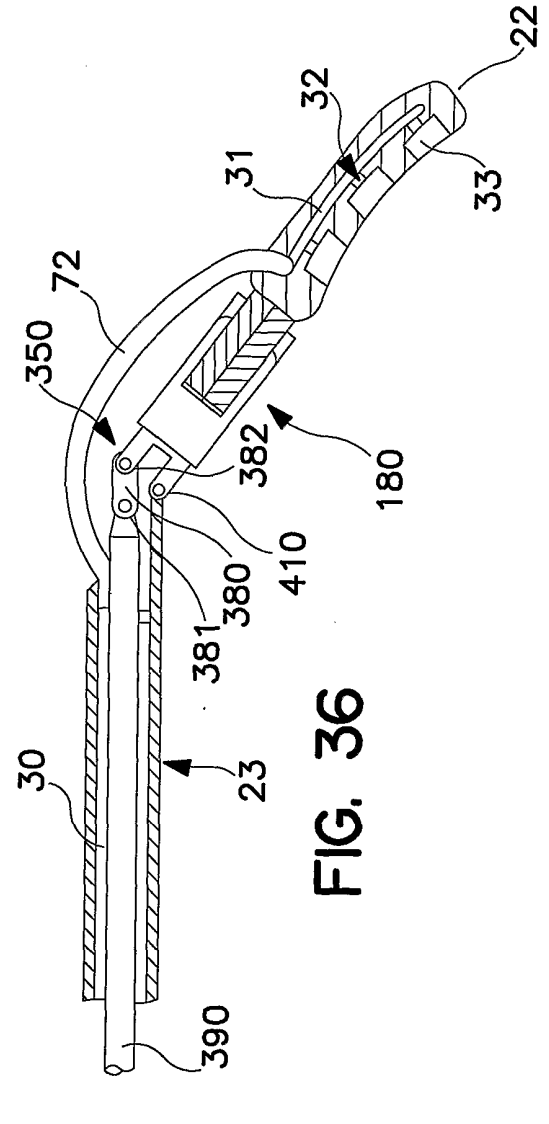

FIG. 36

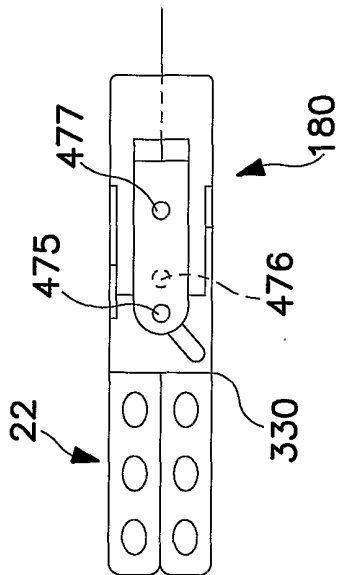

FIG. 37

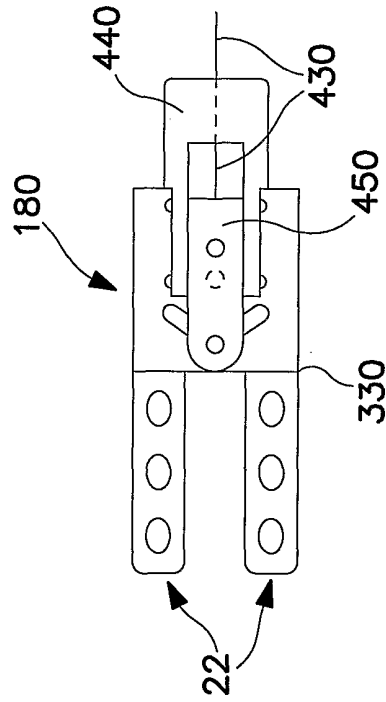

FIG. 38

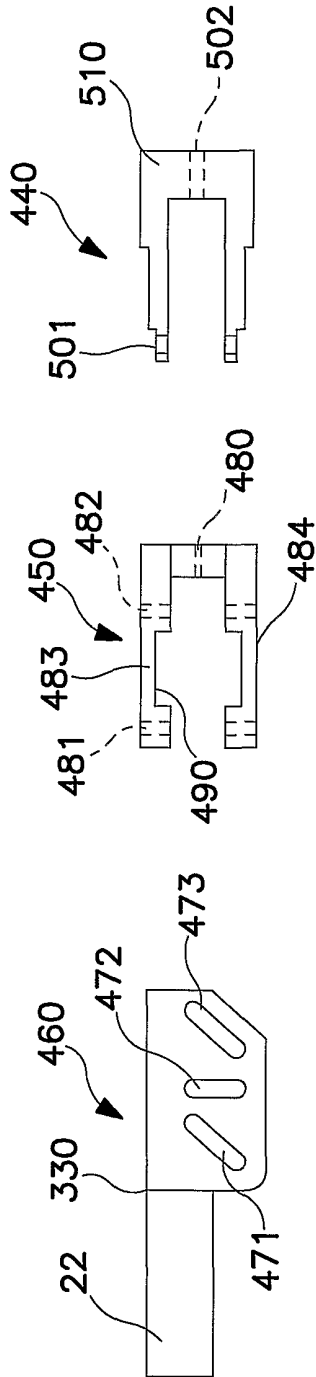

FIG. 43

FIG. 41

FIG. 39

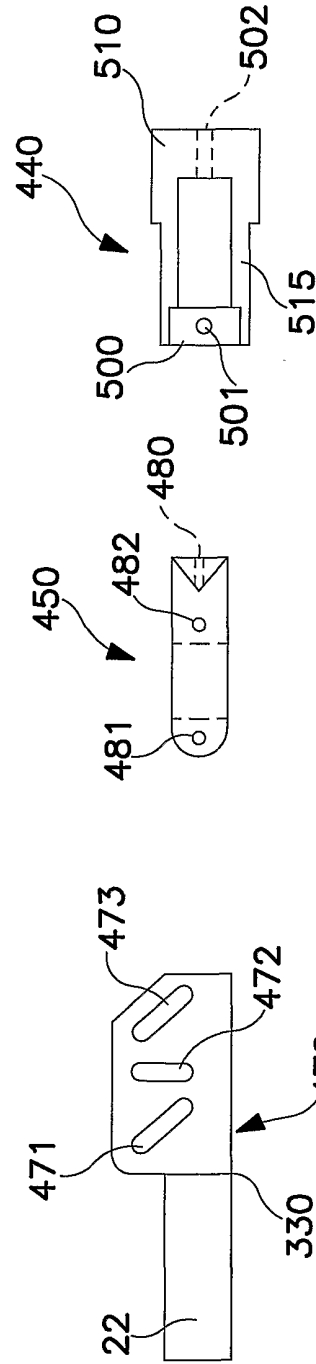

FIG. 44

FIG. 42

FIG. 40

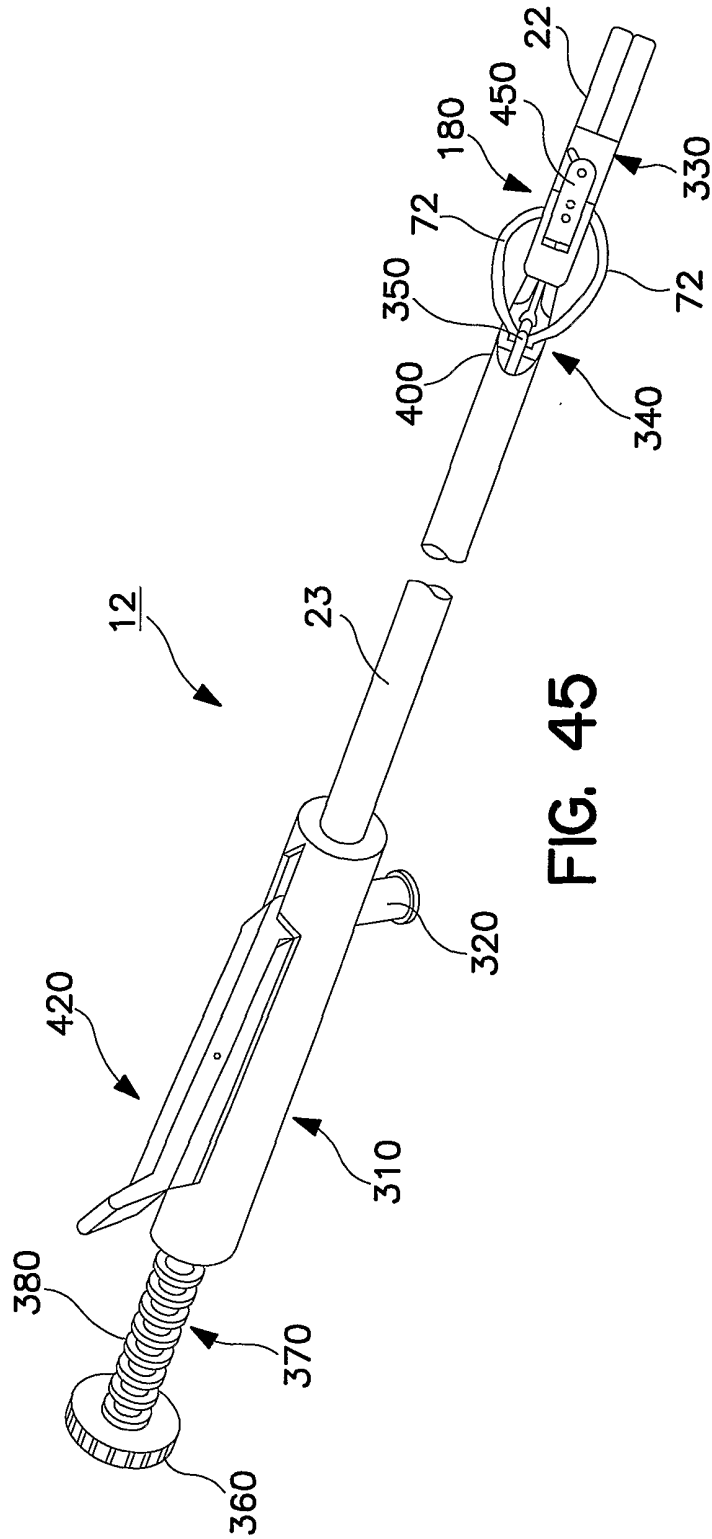

FIG. 45

27/32

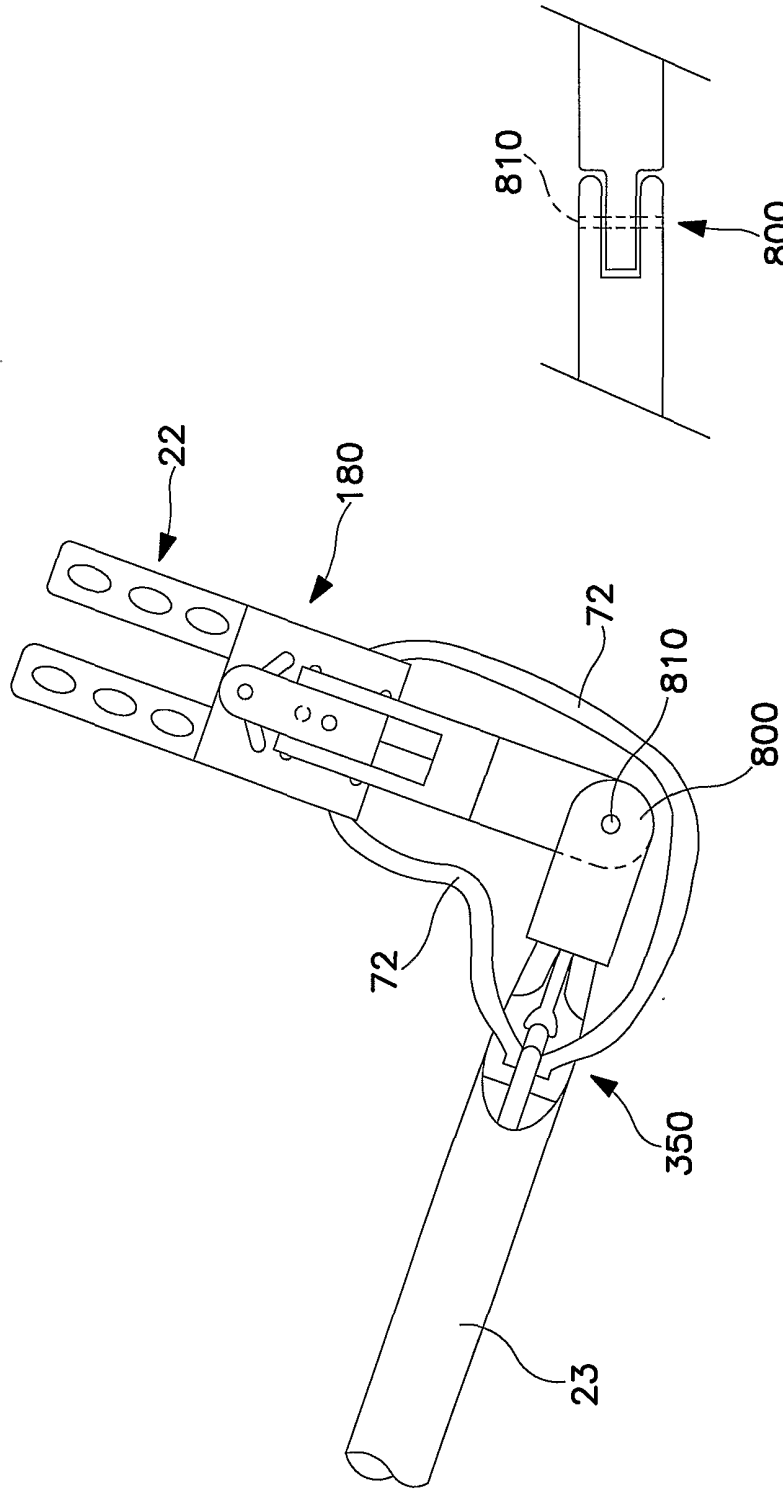

FIG. 47

FIG. 46

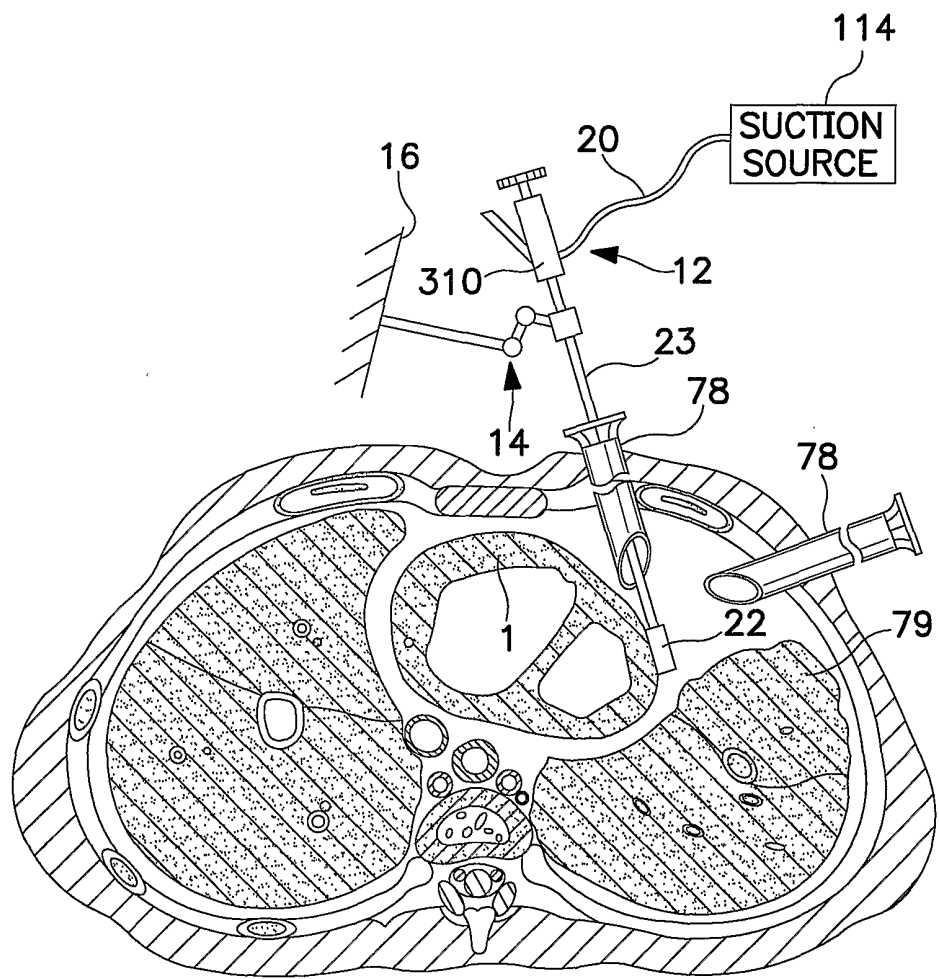

FIG. 48

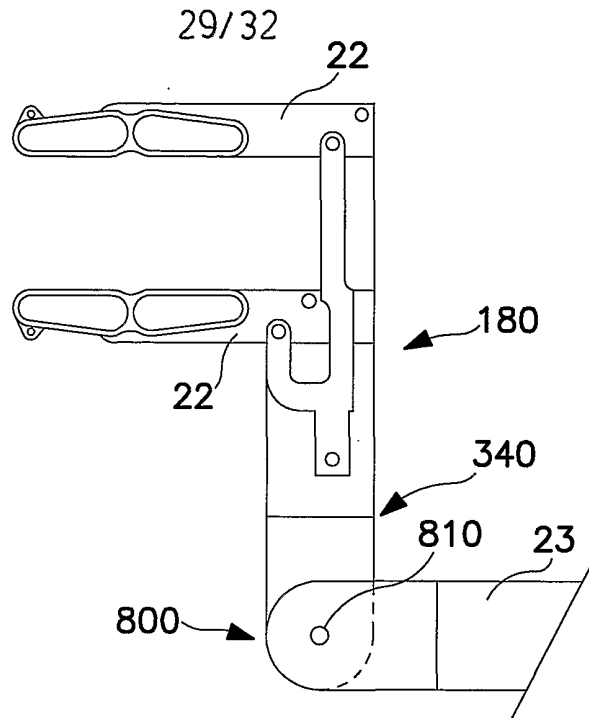

FIG. 51

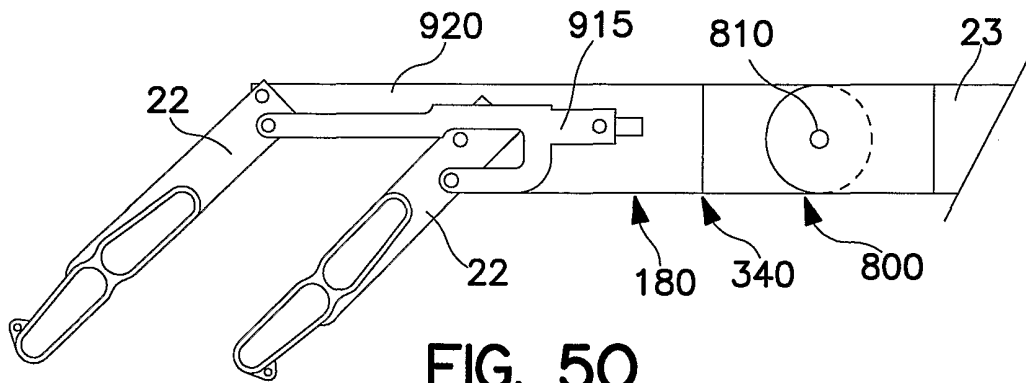

FIG. 50

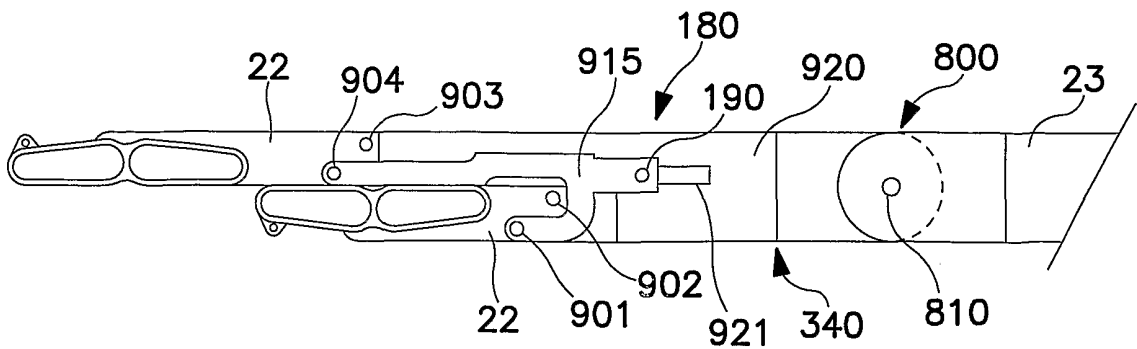

FIG. 49

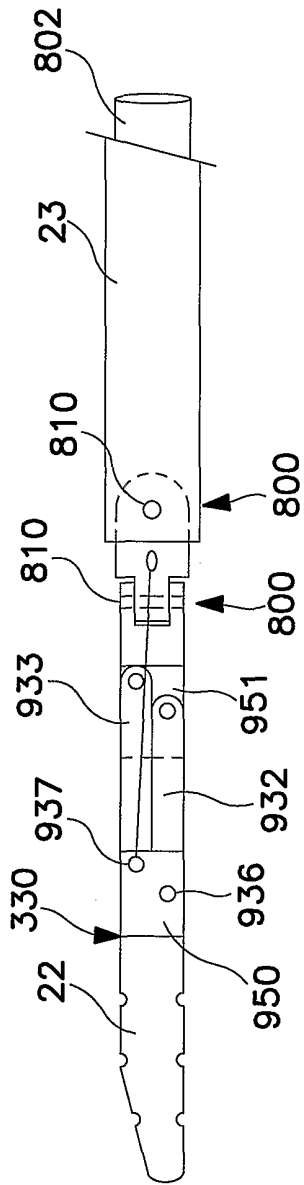

FIG. 52

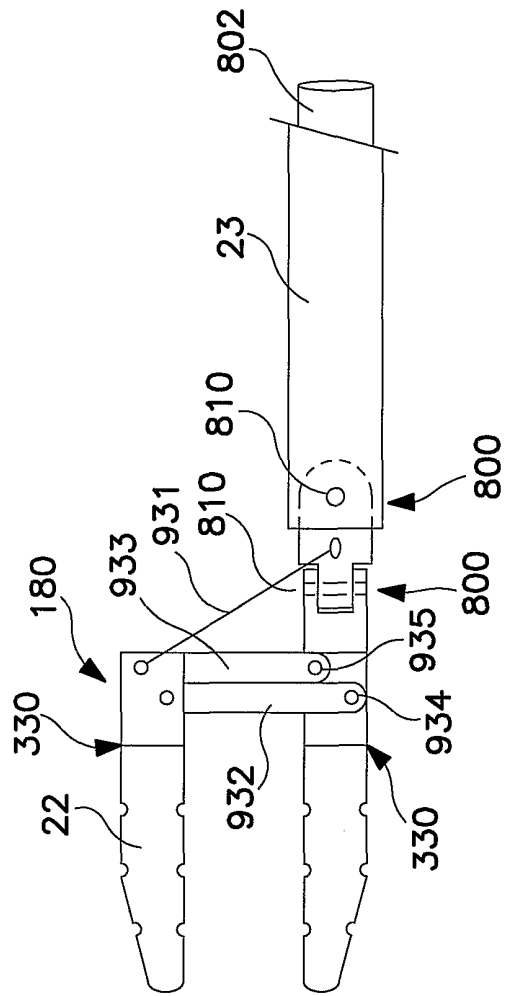

FIG. 53

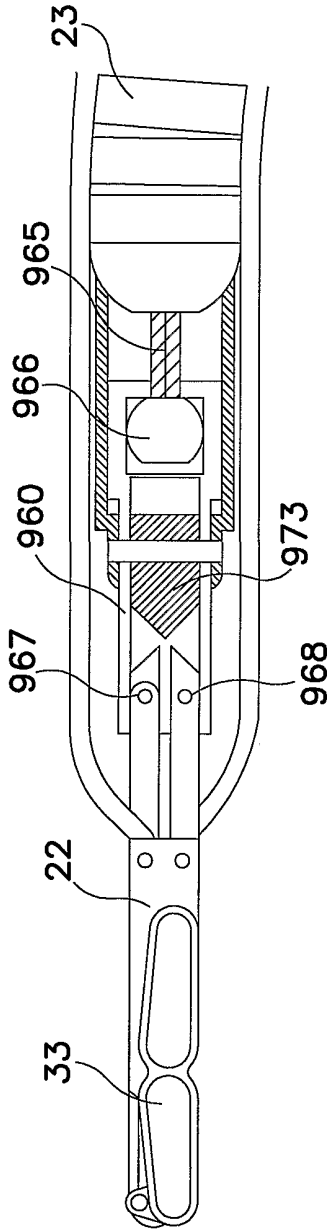

FIG. 54

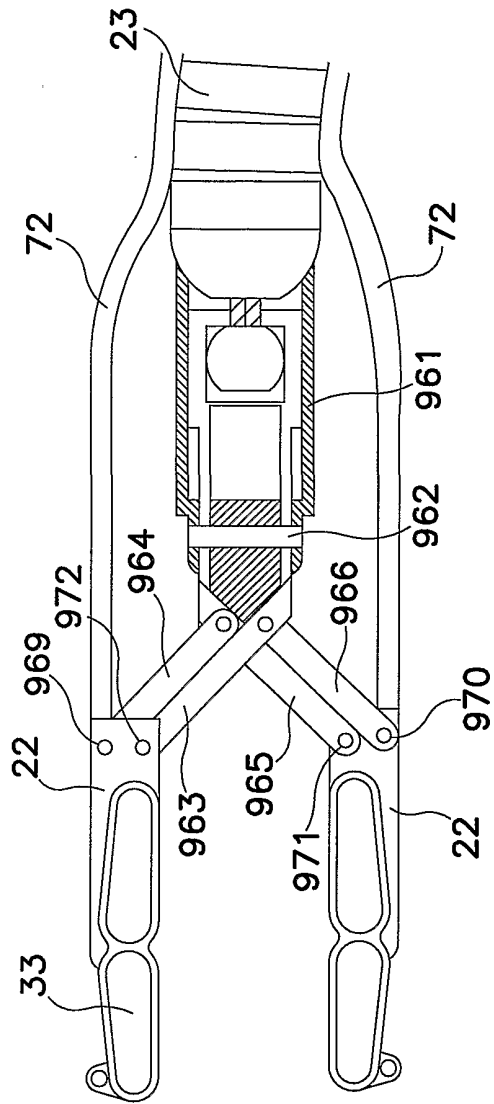

FIG. 55

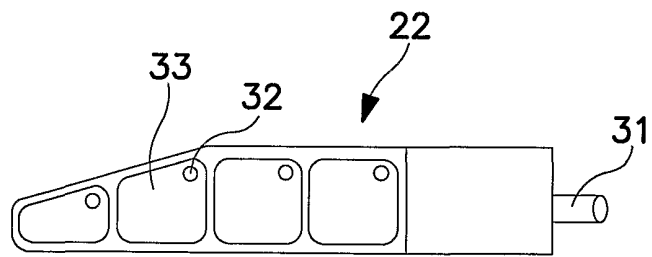

FIG. 56

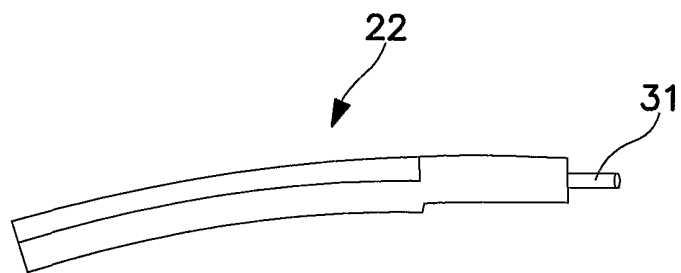

FIG. 57

INTERNATIONAL SEARCH REPORT

International Application No
PCT/US 01/30745

A. CLASSIFICATION OF SUBJECT MATTER IPC 7 A61B17/02 A61B19/00		
According to International Patent Classification (IPC) or to both national classification and IPC		
B. FIELDS SEARCHED		
Minimum documentation searched (classification system followed by classification symbols) IPC 7 A61B		
Documentation searched other than minimum documentation to the extent that such documents are included in the fields searched		
Electronic data base consulted during the international search (name of data base and, where practical, search terms used) EPO-Internal		
C. DOCUMENTS CONSIDERED TO BE RELEVANT		
Category °	Citation of document, with indication, where appropriate, of the relevant passages	Relevant to claim No.
X	US 6 015 378 A (MANSVELT BECK HENDRICUS J ET AL) 18 January 2000 (2000-01-18) the whole document	1-31
X	WO 99 16367 A (ALLIANCE MEDICAL TECHNOLOGIES) 8 April 1999 (1999-04-08) page 11, line 15 -page 12, line 8; figures 16,17	1-5,8, 10-13, 17,18, 22-27,31
Y	---	14,15
	--- -/--	
<input checked="" type="checkbox"/> Further documents are listed in the continuation of box C. <input checked="" type="checkbox"/> Patent family members are listed in annex.		
° Special categories of cited documents :		
A document defining the general state of the art which is not considered to be of particular relevance *E* earlier document but published on or after the international filing date *L* document which may throw doubts on priority claim(s) or which is cited to establish the publication date of another citation or other special reason (as specified) *O* document referring to an oral disclosure, use, exhibition or other means *P* document published prior to the international filing date but later than the priority date claimed		*T* later document published after the international filing date or priority date and not in conflict with the application but cited to understand the principle or theory underlying the invention *X* document of particular relevance; the claimed invention cannot be considered novel or cannot be considered to involve an inventive step when the document is taken alone *Y* document of particular relevance; the claimed invention cannot be considered to involve an inventive step when the document is combined with one or more other such documents, such combination being obvious to a person skilled in the art. *&* document member of the same patent family
Date of the actual completion of the international search 7 March 2002		Date of mailing of the international search report 19/03/2002
Name and mailing address of the ISA European Patent Office, P.B. 5818 Patentlaan 2 NL - 2280 HV Rijswijk Tel. (+31-70) 340-2040, Tx. 31 651 epo nl, Fax: (+31-70) 340-3016		Authorized officer Ducreau, F

INTERNATIONAL SEARCH REPORT

 International Application No
 PCT/US 01/30745

C.(Continuation) DOCUMENTS CONSIDERED TO BE RELEVANT		
Category °	Citation of document, with indication, where appropriate, of the relevant passages	Relevant to claim No.
X	EP 0 993 806 A (MEDTRONIC INC) 19 April 2000 (2000-04-19) page 6, paragraph 45; figures 2,6 page 10, line 55 - line 56; figure 44 figures 22-29 ----	1-5,8, 10-13, 17-19, 22-27,31
X	WO 98 17182 A (GENZYME CORP) 30 April 1998 (1998-04-30) page 15, line 6 - line 23; figures 13,14 ----	1-6,8, 10-13, 17, 22-28,31
X	WO 98 49947 A (RIESS ANDREAS G) 12 November 1998 (1998-11-12) abstract; figures 2-4 ----	1,2,4-6, 8,10-14, 16,19, 22-28,31
Y	US 5 749 892 A (ROTH ALEX T ET AL) 12 May 1998 (1998-05-12) figures 1,3A,3B,5 ----	14,15
A	US 5 836 311 A (MANSVELT BECK HENDRIOUS J ET AL) 17 November 1998 (1998-11-17) column 6, line 44 - line 55; figures 9,10 column 7, line 48 -column 8, line 3; figure 14 -----	1,22,31

INTERNATIONAL SEARCH REPORT

Information on patent family members

International Application No.

PCT/US 01/30745

Patent document cited in search report		Publication date	Patent family member(s)	Publication date
US 6015378	A	18-01-2000	US 5836311 A	17-11-1998
			US 6334843 B1	01-01-2002
			US 6328688 B1	11-12-2001
			US 6350229 B1	26-02-2002
			US 6336898 B1	08-01-2002
			AU 7241496 A	09-04-1997
			BR 9610670 A	06-07-1999
			CA 2232580 A1	27-03-1997
			CN 1198664 A	11-11-1998
			EP 0939605 A1	08-09-1999
			JP 11511366 T	05-10-1999
			NO 981289 A	19-05-1998
			WO 9710753 A1	27-03-1997
			US 5927284 A	27-07-1999
WO 9916367	A	08-04-1999	AU 9664398 A	23-04-1999
			WO 9916367 A1	08-04-1999
EP 0993806	A	19-04-2000	AU 5704399 A	03-04-2000
			BR 9913759 A	12-06-2001
			EP 0993806 A2	19-04-2000
			NO 20011296 A	14-05-2001
			WO 0015119 A2	23-03-2000
WO 9817182	A	30-04-1998	AU 733169 B2	10-05-2001
			AU 4599697 A	15-05-1998
			EP 0944356 A1	29-09-1999
			WO 9817182 A1	30-04-1998
			US 6152874 A	28-11-2000
WO 9849947	A	12-11-1998	DE 29708050 U1	17-07-1997
			WO 9849947 A1	12-11-1998
			EP 0981297 A1	01-03-2000
US 5749892	A	12-05-1998	US 6017304 A	25-01-2000
			US 6139492 A	31-10-2000
			US 6149583 A	21-11-2000
			US 5807243 A	15-09-1998
US 5836311	A	17-11-1998	AU 7241496 A	09-04-1997
			BR 9610670 A	06-07-1999
			CA 2232580 A1	27-03-1997
			CN 1198664 A	11-11-1998
			EP 0939605 A1	08-09-1999
			JP 11511366 T	05-10-1999
			NO 981289 A	19-05-1998
			WO 9710753 A1	27-03-1997
			US 6334843 B1	01-01-2002
			US 6328688 B1	11-12-2001
			US 6350229 B1	26-02-2002
			US 6336898 B1	08-01-2002
			US 6015378 A	18-01-2000
			US 5927284 A	27-07-1999